

Digitized by the Internet Archive
in 2008 with funding from
Microsoft Corporation

RETROSPECT AND PROSPECT

EDITORIAL OBSERVATIONS.

FROM a study of the opinions regarding the business outlook forwarded us by a thoroughly representative body of Canadian manufacturers, the outstanding fact is clearly established that no setback is in immediate prospect, and that the gigantic strides made in progress and development during the past year will form but stepping stones to a still higher degree of achievement in the year on which we have entered.

When we consider the number and variety of manufacturing plants which have recently sprung into existence or have been extended and enlarged, and take cognizance of their more or less successful record of competitive production, it is forcibly impressed upon us that not a little glory attaches to our "Captains of Industry" under whose guidance and direction this desirable consummation has been brought about. The note is one of optimism and it strikes a responsive chord in the heart of every citizen of the Dominion. Combined with this optimism, there is unbounded confidence shown in the various enterprises undertaken, and whether we occupy the position of director or operator, there is inspiration to be derived which will impart impetus to our efforts to help in our country's upbuilding.

A perusal of the editorial pages of this number will convince the most sceptical that the foundations of a great industrial future are being laid in this land, and if favored by a succession of bountiful harvests (agricultural and horticultural), together with the continued reclamation of our mineral wealth, there is, without doubt, in store for us, a consistently accelerating progress towards our attaining in a few years a high place among the commercial nations of the world.

LOCOMOTIVE OUTLOOK FOR 1913.

THE Canadian Locomotive Co., Ltd., have supplied the following facts, indicating the great progress they have made in the past, and showing what can be expected from them in the future. The output of their plant to-day is 9 engines per month; when the present company took hold, it was only 5 en-

gines per month. The output should increase to 25 per month when the improvements going on are completed. The present plant consists of power house, boiler shop, tank shop, smith shop, tender shop, upper and lower machine shop, carpenter shop, pattern shop and erecting shop.

The construction of new shops is being rushed with all possible dispatch, and one of them, the tank and tender shop, is now complete and in operation. This building is 345 x 70 ft., and the equipment is modern. A new foundry is under way, which will be about 152x115 ft., and will be equipped with everything of the latest and newest design.

A new erecting shop will be built, which will be able to take care of 25 engines per month. A new machine shop is also being built which will be about 200 x 75 ft., and equipped in the most modern fashion. A new pattern and carpenter shop is at present under course of construction, and should be finished early in the new year. New offices will also be built in 1913.

THE MACHINE TOOL OUTLOOK.

IN response to an enquiry as to what were the machine tool prospects for the year 1913, the A. R. Williams Machinery Co., Ltd., write:—"Trade conditions for the past year in our line have been very encouraging indeed, and while we cannot report anything like the boom for machinery of 1907, yet the conditions are such as to indicate a steady growth in the industrial development of the country. Manufacturers, too, are beginning to realize that the increased competition which accompanies this growth, calls for more up-to-date methods, and there is an increasing demand for modern rapid production tools and equipment.

"The outlook for 1913 seems to be unusually bright. The rapidly increasing value of the Canadian markets is attracting the attention of manufacturers the world over, and the necessity of competing successfully for the rich harvest that is offered in the growing needs of the Canadian people, renders closer and more intimate connections with this country necessary, and we confidently look for-

ward to a larger influx of American manufacturers during the new year than ever before.

"English and European manufacturers are also beginning to realize more than ever the profitable field which awaits their enterprise in Canada, and to throw aside in some degree the conservatism that has hitherto marked their attitude to the developments in manufacturing conditions, which demand radical changes in machine tool design, and are beginning to realize that if they would compete successfully in our market they must adapt their product to the standards and conditions of a new country."

HON. NATHANIEL CURRY'S VIEWS.

CONCERNING my views on the trade outlook, there is probably no prophet on such matters pessimistic enough to predict anything but a banner year for Canada in 1913, unless he be a war prophet as well. This possibility is always more or less in evidence and of course it looms large at present, but we depend on the diplomacy of the Powers to avert any such disaster.

Speaking from a manufacturing standpoint, I do not think you can find any manufacturer who is not looking forward to and making provision for a substantial increase in his business. The railways are a tell-tale in this respect, and they have made the largest purchases of rolling stock and other equipment in their history, to provide for the new year's traffic.

The amount of new building, as well as extensions and improvements to existing plants throughout Canada, is of such extent as to make it almost impossible for the builders to procure materials and complete their contracts in the specified time.

With regard to the question of bounty and tariff legislation, a sufficient supply of steel and iron is the foundation of manufacturing, and this supply should be furnished by Canadian companies. The danger and uncertainty of depending on British and foreign countries for these commodities is being keenly felt at the present time. The demand in the United States, during at

1335-29
27/7/14

least another year, for strictly home consumption, will be greater than the total output of American furnaces, consequently Canadian manufacturers find it impossible to get anything like the tonnage required and contracted for, and I am afraid that many Canadian industries will suffer during the next twelve months for want of iron and steel. In my opinion, the Government should consult with our large makers of iron and steel, and offer such encouragement as will result in the early enlarging and equipping of their works, sufficient to take care of Canadian wants and for the making and rolling of all sections and shapes that now have to be imported.

Senator Curry is an ex-president of the Canadian Manufacturers' Association and is well known as a director of many industrial undertakings throughout the Dominion.



THOS. CANTLEY'S VIEWS.

THE conditions governing the iron and steel trade of Canada, during year 1912, were unique, the consumption of iron and steel products by the railway and engineering works of the country being greater, and the demand from all sources larger, than ever before in Canada's history. The iron, steel and engineering trades of Great Britain, Germany, and other Continental countries were also, in a highly prosperous condition, and prices in their markets continued to advance throughout the whole of the year.

Dumping by U.S. Iron Masters.

With an enormous home demand and great prosperity in Europe, it would have been natural to suppose that satisfactory prices would have been obtained by the Canadian producers. Such, however, was not the case, due entirely to the action of the iron masters of the United States who, during the first half of the year, flooded our market with both raw pig-iron and finished steel bars, dumped into Canada quite irrespective of profit or even of cost of production. The extent to which the Dominion was thus utilized as a dumping market is shown by the fact that of the entire export trade of the United States in pig iron, ninety per cent. was disposed of in Canada. To this there must be added a further enormous tonnage in finished steel products, a considerable portion, at least, of which was sold in our central provinces at prices fully twenty-five per cent. below that at which they were selling raw pig iron some five years ago.

The middle of the second quarter of the year saw a slight pause in the Ameri-

can scramble to sell, and a couple of months later Canadian consumers who had a few months before contracted with United States mills for large amounts of tonnage of finished steel, found it difficult to get deliveries even though willing to pay a premium of several dollars a ton for prompt shipment. Conditions, thereafter, improved materially, and the last quarter of the year has brought with it very considerable improvement in most directions, although some of the Canadian mills have doubtless considerable tonnage on their books taken at prices very much below those now ruling. Thus, notwithstanding the enormous demand, Canadian producers found their earnings for the year 1912 very much less than they should have been, owing to the totally inadequate customs tariff which applied to a very considerable percentage of iron and steel products thrown into Canada by the United States furnaces and mills.

Consumption and Production.

The Canadian consumption of iron and steel products for the first half of the past year was over 30 per cent. greater than the corresponding period of 1911, while the increase in production will probably be found to be in the vicinity of 15 to 18 per cent.

The growth in production, in view of the disappointing profits obtaining in the operation of the Canadian plants during the past two years, is, we think, indicative of the fact that the iron and steel operators have faith in the growth of the country and look forward to such a readjustment of the tariff as will correct, and make less harmful than during the past few years, the dumping of surplus products by their neighbors to the south of the international boundary.

Nova Scotia Steel & Coal Co. Output.

The outputs of the Nova Scotia Co. for the year 1912 will probably be about as follows:

	Tons.
Coal, total quantity mined	855,000
Iron ore, mined at Wabana	563,000
Pig iron and open hearth steel output will total, say the former	68,600
and the latter	80,600

The last two items are somewhat less than for the previous year, due to the fact that the blast furnace was out of commission forty-five days, from March 25th to May 9th, during which period it was completely relined, the necessity for which was foreshadowed in the annual report of 1911. The total shipments from the New Glasgow works exceeded 75,000 tons, and the order-books of the Scotia Company are at present well filled.

It is expected that the iron ore output will be considerably larger than that of any past year, due entirely to the large increase in the output of the submarine sections of the company's Wabana property. The entire quantity which it is thought will be available during 1913 has already been sold at favorable prices.

Important Events in the Steel Industry.

The early summer saw the culmination of two very important stages in the industrial progress of Canada. These consisted in the completion of the necessary installation and initial operation of a plant for fluid compressing steel ingots by the Harmet process, at Sydney Mines, and the successful inauguration at New Glasgow of a modern forge equipped with hydraulic presses, replacing steam hammers for heavy work. The Harmet fluid compression plant consists of two groups—one group of presses dealing with ingots of three to five tons; the other having a capacity for large ingots of from fifteen to twenty-five tons in weight.

Following the installation of the fluid compression plant at Sydney Mines, the new forge department at New Glasgow was brought into operation. Here, steam-hydraulic forging presses of 4,000 tons capacity replace the old steam-hammer in vogue during the first forty years of the company's existence. This equipment is equal, and in some important respects is superior, to any on this continent, and places the Scotia Company in the forefront as producers of forgings. The work of both these units has been in the highest degree satisfactory; the fluid pressing process produces metal free from unsoundness and especially suitable for use where the highest degree of reliability is desirable. The forging press manufactures this steel into forgings of the best grade obtainable.

As to the future, the consumption requirements of the country are large and certain to grow. The only factor necessary to ensure that our iron and steel producing capacity of the country shall keep pace with its increased requirements is a readjustment of the metal tariff such as will give a reasonable amount of protection, taking into account the increased labor, assembly and distribution costs in comparison with those of foreign competing countries.



MAYOR T. R. DEACON, WINNIPEG.

FOR the first time in its history, Winnipeg has a Mayor, a leading manufacturer. Mr. T. R. Deacon, the present occupant of the office, is the managing director of the Manitoba Bridge and Iron Works Co., Ltd., whose business has

grown very rapidly since he started it not many years ago. Although the work of developing such a business has been very strenuous, nevertheless Mr. Deacon has found time to give to public business. When the interests of manufacturing have been at stake. Mr. Deacon has always been in the front rank of those who sought to protect the struggling industries of a new city. He knew that the difficulties to overcome were not slight, and it was his constant aim to encourage more general interest in manufacturing.

When asked to tell of the experience of Winnipeg during the year, 1912, he said:

Increase in Output.

"Manufacturing in Winnipeg has increased during the year 1912 by over 30 per cent., and this is general throughout all the various lines of goods manufactured in the city, and does not include a number of new factories that have been built and have not yet commenced to manufacture.

"The advent of abundance of cheap power has given a stimulus to manufacturing here, and while the high price of land has been to a certain extent a deterrent to the larger lines of manufacturing establishing in the city, it is not so serious in the case of smaller or lighter lines that can utilize several floors of a building, and these latter are rapidly multiplying in the city.

Real Estate and Capital.

"Owing to the large profits that have been available from land transactions, and the high rate of interest obtainable from mortgage loans, it has not been easy to obtain capital for industrial enterprises; yet, 106 new charters for industrials have been granted in the city of Winnipeg during the past year, with an authorized capital of \$14,250,000, and old companies have increased their authorized capital by \$4,500,000. Building permits have been issued for factory buildings and extensions to the extent of \$1,750,000 during the year.

Pay Roll \$1,000,000 a Month.

"The present strictly manufacturing pay roll is about \$1,000,000 per month, distributed among 16,500 employees, and the total output for the year will be in the neighborhood of \$51,000,000 worth of manufactured product. Stability of tariff conditions has given more confidence to investors in this line, and a steady growth of industrial development throughout all Western Canada is now assured."



It may be taken for granted that costs got out in the old style are never available for any practical purpose other than accountancy use.

CENSUS OF CANADA'S INDUSTRIES.

THE information obtained from the census of the manufactures of Canada taken in June, 1911, has just made its appearance in the form of a bulletin from the Government Census Department. Some of the data was made public by Mr. Archibald Blue in a speech at the annual meeting of the Manufacturers' Association in September, but much is entirely new.

The returns show that at the time of the census, Canada had 19,218 manufacturing establishments, with a capital of \$1,247,573,609; 215,193 employees; a pay roll of \$645,288,733; using raw materials to the value of \$601,509,018, and turning out products to the value of \$1,165,975,639.

Growth in Ten Years.

In ten years the number of establishments increased by 4,568; capital by \$800,000,000; employees by 176,000; wages by \$128,000,000; raw materials handled, by \$335,000,000, and finished products by \$685,000,000.

The extensive development of Canada's industries is indicated by the immense output of some of the establishments. One in Nova Scotia, during 1910, turned out more than eight million dollars' worth of products; one in Ontario, more than nine million dollars' worth, and two in Quebec, more than ten million dollars' worth. There were fourteen establishments which had a production just under seven million dollars each for the year.

Ontario in Lead.

Ontario continues the banner Province for manufacturing, having 6,543 establishments; Quebec comes next with 4,845; Nova Scotia following with 1,188; New Brunswick, 919; British Columbia, 392; Prince Edward Island, 334; Manitoba, 324; Alberta and Saskatchewan together, 105.

The figures indicate that amalgamation was practised in Ontario to a very large extent, as during the last five years the number of manufacturing establishments increased by only five, while the total capitalization of the Ontario manufacturing companies increased by \$200,000,000, the number of employees by fifty thousand, the amount of wages paid by \$55,000,000, and the total production by \$210,000,000.

In Quebec, the number of establishments showed an increase of 1,619 in five years; the total capitalization \$71,000,000; the number of employees, 39,000; the wages paid them \$22,000,000, while the total production of the factories showed an increase of \$131,000,000.

Alberta Ahead in Product Value.

The Province with the highest rate of increase in the value of products during the last ten years was Alberta, with 1,331 per cent.; the amount of increase being \$17,500,000. During the same time, Manitoba increased in manufactured products by \$41,000,000 or 315 per cent.; British Columbia increased by \$46,000,000 or 235 per cent.; Quebec by \$192,000,000, or 121 per cent.; Ontario by \$338,000,000, or 140 per cent.; Saskatchewan by \$5,680,000, or 871 per cent.

Fourteen Leading Cities.

Among the cities, Montreal continues in the first place as a manufacturing centre. In 1910, the value of manufactured products in Montreal proper was \$166,000,000, an increase of 146 per cent. in twenty years. However, including Maisonneuve, Westmount, and Lachine, which are essentially a part of the Montreal industrial centre, the value of the production for the year was \$115,000,000, which is an increase of 168 per cent. in twenty years.

The value of production in Toronto was \$154,000,000, an increase of 234 per cent. in twenty years. Hamilton takes third place as a Canadian manufacturing centre, with a production of \$65,125,000; Winnipeg is fourth with a production of \$32,694,000; Ottawa fifth with \$20,954,000; Quebec sixth with \$17,149,000; London seventh with \$16,273,000; Brantford eighth with \$15,070,000; Vancouver ninth with \$15,866,000; Halifax tenth with \$12,140,000; St. John eleventh with \$10,089,000; Sydney twelfth with \$9,395,000; Berlin thirteenth with \$9,266,000; Calgary fourteenth with \$7,751,000.



FREIGHT RECORD THROUGH SOO CANALS.

MORE than ten million tons greater than the record of 1910, the previous best was the volume of freight carried through the canals at the Soo during the 1912 season, as shown in the statistical report just issued. While shipments of practically every commodity except soft coal show an increase over the three previous periods, the movement of iron ore, 46,303,423 tons, was greater by more than 4,699,789 tons, than in 1910, the season showing the greatest previous shipments.

Wheat.

The movement of wheat, 174,086,456 bushels, was 60,832,895 bushels greater than in 1909, while the total grain shipments show a gain of 12,505,095 bushels over the record of that year.

Coal.

Although the movement of hard coal was delayed in starting by mine difficul-

ties early in the season, the shipments, 2,142,485 tons, were 82,276 tons greater than the previous high record of 1911. The movement of soft coal, amounting to 12,789,109 tons, was 483,558 tons below 1911, due chiefly to delay in getting the product from the mines to the loading docks owing to car shortage.

Lumber.

Lumber shipments were 667,542,000 feet, a gain of 64,441,000 feet over the high record of 1910.

Passenger Traffic.

Passenger traffic shows a considerable falling off, the number carried through the canals, 66,877, having been 56 fewer than in 1910, and showing a loss of 13,074 or 16 per cent., compared with 1911. For this, the unseasonable cold weather early in the year is held chiefly responsible.



Gossip of the Trade

Mr. J. H. Plummer, president of the Dominion Iron and Steel Corporation, who visited Montreal recently, announced that nobody would be appointed in the meantime to replace M. J. Butler, who resigned his position as general manager of the Dominion Iron and Steel Corporation.

St. Thomas, Ont.—The management of the Erie Iron Works have notified contractors of their intention to call tenders for the enlargement of their works. Much new machinery will be purchased.

Montreal, Que.—The taking over of the National Bridge Company, by the Dominion Bridge Company, although not yet ready for official announcement, is considered as good as accomplished. It is understood that the Dominion Bridge directorate will guarantee the interest on the \$560,000 6 per cent. bonds of the National Company, and that the \$5,000,000 National common stock will be exchanged at the ratio of one of Dominion for four of National. The directors of the National Company are Messrs. J. N. Greenshields, President; William Lyall, W. G. M. Shepherd, Hon. Robt. MacKay and H. W. Beaulere. Mr. Jas. Ross is President of the Dominion Bridge Company, and is its largest shareholder.

St. Catharines, Ont.—The foundry plant of Steel & Radiation, Ltd., was formally opened here on November 29, by Sir Henry Pellatt, President, and the Vice-President, his Honor the Lieutenant-Governor, Sir John Gibson, in the presence of Mr. Frederick Nicholls and other directors, along with the Mayor and Council of the St. Catharines Board of Trade. Two hundred men are now employed at the new plant, which is situated on thirty-seven acres along the

Welland Canal. The company expects soon to have six hundred men on the payroll. As a part of the ceremony, the first radiator ever produced in St. Catharines, was cast.

The Dominion Foundry Supply Co., Ltd., report an excellent year's business during 1912. Among other orders recently filled may be noted the following:

One No. 7 Whiting cupola for the Moffat Stove Co., Weston, Ont.

One No. 3½ Whiting cupola for Marsh & Henthorn, Belleville, Ont.

One No. 5 Whiting cupola, 2-ton pneumatic elevator and drawer type core ovens for the Canada Foundry Co.'s ornamental iron work foundry.

They have also just received an order for two No. 7 Whiting cupolas for the Standard Ideal Co., Port Hope, Ont.

The Dominion Foundry Supply Co., Ltd., also supplied all the overhead electric travelling cranes for the new shops of the National Steel Car Co., Ltd., at Hamilton, Ont. The order comprised five 10-ton and one 5-ton cranes. Two 10-ton travellers are now on order for the Pratt & Letchworth plant at Brantford, Ont.

The Michigan Central Railroad Co., St. Thomas, Ont., have in project a new shop with modern equipment which will be capable of taking care not only of present requirements but those of the future for a period of probably twenty years.

The Goold, Shapley & Muir Co., Ltd., Brantford, Ont., report that the year 1912 has been fully up to their expectations, being the largest so far as output is concerned in the history of their business. The prospects for the New Year 1913 are also exceedingly bright.

The E. B. Eddy Co., Hull, Que., are at present reconstructing their whole power system, and are installing an entirely new electrical plant. Construction has been going on for over a year and it is expected that another year will elapse before the whole work is completed.

The Smart-Turner Machine Co., Ltd., Hamilton, Ont., recently secured the following orders:—Mr. Wm. Birmingham, Goderich, Ont., duplex pump; Pratt & Whitney Co., Dundas, Ont., duplex pump; W. A. Mustard, Baysfield, Ont., rotary pump; Mr. Stephen Wellington, M.E., Madoc, Ont., duplex pump; The Breslau Brick Co., Breslau, Ont., duplex pump; L. H. Gouillard, East Angus, Que., centrifugal pump.

The Canadian Locomotive Co., Ltd., Kingston, Ont., report that since the improvements have been started in connection with their plant, the output has shown a steady increase. From the 1st of July up to December 3, thirty-seven engines of varied sizes and types were

turned out, and the orders on hand at the present time indicate that every department will be fully employed until about next September.

The Russell Motor Car Co., Ltd., West Toronto, Ont., report that the year 1912, has been an exceedingly prosperous one for the company, a large production having been maintained at a fair profit. During that period, there has been erected on the premises a new factory four stories in height, 66 feet by 170 feet, which will provide accommodation for the employment of 300 additional men. A new office building has also been erected and opened at the factory.

Company Reorganized.—The Williams Mfg. Co. has been reorganized with a capital of \$1,000,000. The company's products are sewing machines and typewriters, and additional capital is being secured in order to permit of extensions being carried out that will result in a much larger output than at present. Among the incorporators of the reorganized company are: Messrs. C. W. Davis, B. McLennan, James Rodger and William Yuile, Montreal, and Charles Tutton and Alexander Langlois, of Plattsburgh, N.Y.

Port Mann, B.C.—Announcement has been made by Col. A. D. Davidson, land commissioner of the Canadian Northern Railway, that arrangements are completed for the immediate construction of car building shops at Port Mann, B.C. The plans provide for machine shops, repair shops for cars and locomotives, storehouses, lumber sheds, yard, etc.



THE CHRISTMAS SPIRIT.

TO show their appreciation of the loyal assistance of their employes in making the past year a successful one, the board of directors of the **Union Twist Drill Co., of Athol, Mass.**, at a meeting held December 11, voted that the sum of 2 per cent. of wages earned during the past year be paid to those in the employ of the company, directly after January 1. The gift amounts to about one week's pay for those who worked full time throughout the year.

The same spirit of generosity was evinced by the **L. S. Starrett Co., of Athol, Mass.**, makers of the tools carrying the name of Starrett. In a circular to their employees they tell of the prosperity and progress of the past year, adding that their workers were appreciating the fact that quality of product was the chief thing, following which, came efficiency and loyalty. The directors have decided to pay each person employed by the company two per cent. of the wages earned during the year 1912.

The MacLean Pub. Co., Ltd.

(ESTABLISHED 1888.)

JOHN BAYNE MACLEAN - - - President
H. T. HUNTER - - - General Manager

PUBLISHERS OF

CANADIAN MACHINERY

AND MANUFACTURING NEWS

A monthly newspaper devoted to machinery and manufacturing interests, mechanical and electrical trades, the foundry, technical progress, construction and improvement.

H. V. TYRRELL, - - - Business Manager

PETER BAIN, M.E., - - - Editor

J. H. WILLIAMS, - - - Associate Editor

OFFICES:

CANADA	GREAT BRITAIN
Montreal , Rooms 701-702 Eastern Townships Bank Bldg.	London , 88 Fleet Street, E.C. Phone Central 12960 E. J. Dodd
Toronto , 143-149 University Ave., Phone Main 7324	UNITED STATES
Winnipeg , 34 Royal Bank Bldg., Phone Garry 2313	New York , R. B. Huestis 115 Broadway, New York, N.Y., Phone 2209 Rector
	Chicago , A. H. Byrne Room 607, Marquette Bldg. 140 S. Dearborn St., Chicago

CABLE ADDRESS:

Macpubco, Toronto. Atabek, London, Eng.

SUBSCRIPTION RATE:

Canada, \$1.00; United States, \$1.50; Great Britain, Australia and other colonies, 4s. 6d., per year; other countries, \$1.50. Advertising rates on request.

Subscribers who are not receiving their paper regularly will confer a favor on us by letting us know. We should be notified at once of any change in address, giving both old and new.

Vol. IX. JANUARY 2, 1913 No. 1

PRINCIPAL CONTENTS.

Retrospect and Prospect	1-4
Editorial Observations...Hon. Nathaniel Curry's Views	
...Mayor T. R. Deacon, Winnipeg...Thos. Cantley...	
Census of Canada's Industries, etc.	
Editorial	5
Our New Year's Enterprise....Review Topics Continued in Next Issue.	
Montreal Harbor Commissioner's New Elevator	7
Transcona Shops of the N.T.R.	14
Development of St. John, N.B., as an Ocean Port	17
C.P.R. Terminal at Vancouver	18
Description of the Dominion's Latest Steel Foundry	20
Dodge Mfg. Co.'s Plant, Toronto, Ont.	25
Hamilton Bridge Works Co. New Plant, East Hamilton, Ont.	35
Point du Bets Hydro-Electric Power Station, Winnipeg	41
Industrial Development	53-145
The Brown, Boggs Co., Ltd., Hamilton, Ont....Ford-Smith Machine Co., Hamilton, Ont....The Goldie & McCulloch Co., Ltd....National Steel Car Co., Ltd....Selby & Youlden, Kingston Foundry...New Foundry of Sheldons, Ltd., Galt, Ont....A Creosoting Plant for Ties...Empire Mfg. Co.'s New Smelting Plant...Dominion Wheel and Foundries, Ltd., Toronto...The Steel Company of Canada, Ltd....The Waterous Engine Works Co., Ltd., Brantford, Ont....The Anthes Winnipeg Foundry...Standard Underground Cable Co. of Canada...Standard Steel Construction Co....Ford Motor Co....Hamilton Malleable Iron Co....Crocker-Wheeler Plant...The Canadian Hanson & Van Winkle Co....Witt Twist Drill Co....H. Mueller Mfg. Co., Sarnia...Massey-Harris Co....Canadian Steel Foundries, Ltd....Greenfield Conduit Co....Marsh & Henthorn...C.P.R., Ogden Shops...Western Drydock & Shipbuilding Co....Schnake Machine Works...Henry Hope & Sons, Ltd., Peterborough...Lake Superior Corporation...National Iron Works...Buffalo Union Furnace Co., Port Colborne.	
Industrial News	146-148

OUR NEW YEAR ENTERPRISE.

THE publishers of Canadian Machinery extend to its advertisers and subscribers the season's greetings, and give expression to the hope, that a growing prosperity may continue to mark the dawn of each new day of the year 1913, over whose threshold we have just crossed.

With the development and progress of our country, it has ever been our aim to keep pace, and, in the many opportunities afforded to foster the work, our journal has always been in the forefront as a director and guide. The encouragement, support and commendation which we have received at the hands of all ranks and classes of the mechanical and industrial life of the Dominion during the past year impressed us with a realization that our place and sphere, the fitly filling of which, while highly appreciated, demanded enterprise equally aggressive, if not more so than the progress of the country itself.

It was therefore deemed expedient to mark the opening of the New Year, 1913 by a dual display of effort in the direction indicated. The first of this—the "Annual Review Number of Canadian Machinery," we have placed on record, and without particularizing, we believe it to be, notwithstanding fewer or many shortcomings, worthy of the confidence reposed in us, and an interesting and instructive production from cover to cover.

The second departure from previous arrangements consists in the decision to issue our journal weekly instead of monthly as heretofore. The developments in machinery manufacturing, in the establishment of railroad shops, iron and steel industries and large power plants throughout the Dominion, have, we believe, been such that the interests of both reader and advertiser will thus be better served. It had been our intention to have this weekly number follow directly after that of the "Annual Review," but consequent on some delay in the completion of our plans, and having regard to our practice and desire that our product maintain without question its high standard of excellence, we have decided to delay publication of the weekly issue until January 30th.

The usual mechanical features of the editorial section will be continued, and, in addition, two important departments, which will greatly broaden our field of usefulness, will be found in the weekly. One of these will contain a complete record of new developments, giving opportunity for the purchase and sale of general mechanical equipment. The other will consist of market reports on iron, steel, metals, machinery, etc. The weekly issue of our journal will be invaluable to plant superintendents, foremen and mechanical men generally, while the Industrial News and Market Reports will be of incalculable benefit to manufacturers, their sales and purchasing departments.

The support, co-operation, and encouragement so generously meted out to us during past years is again claimed, and our confidence in the continuance of its receipt is unshaken.



REVIEW TOPICS CONTINUED IN NEXT ISSUE.

WE have been reluctantly compelled to hold over till our next issue a considerable quantity of editorial material on account of lack of space. Articles dealing with "Workmen's Compensation," "Cost Systems," "Factory Design and Construction," "Efficiency, Its Methods and Application" and "Data Concerning Established and Budding Industrial Centres," etc., are some of the features of interest we have been unable to place at this time.

Personal

Mr. John McGill has been appointed assistant manager by the Berg Machinery Manufacturing Company, Toronto.

Superintendent White, of the Eastern Canada Power and Pulp Co.'s ground wood mill at Murray Bay, Quebec, has been appointed superintendent of the new one-hundred-ton ground wood mill, which will be erected by the Abitibi Pulp and Paper Mills.

T. R. Deacon, has just been elected mayor of Winnipeg. Mr. Deacon is a graduate of the University of Toronto in civil engineering of the class of '91, and is president and general manager of the Manitoba Bridge and Iron Works, Limited.

W. P. Ladd, Walkerville will be superintendent of manufacture of the superstructure of the large bridge which the Government is building across the St. Lawrence at Quebec, for which the St. Lawrence Bridge Co. has taken the contract. He has already been overseeing the building of the company's vast shops which are now near completion, situated near Montreal. The completed shops of the new bridge company will represent an outlay of over three-quarters of a million dollars. A start will be made on the bridge at the beginning of the year. William B. Fortune, who has had extensive experience in erecting large bridges in the United States, has been appointed general superintendent in charge of the construction of the St. Lawrence bridge.

Mr. W. Cook Hunter, of St. John, N.B. has been appointed manager of the Record Foundry & Machine Co., with headquarters at Moncton, N.B. Mr. A. E. Peters, the former manager and president, has retired from the management at his own request. Mr. Hunter was formerly a locomotive engineer on the I.C.R. and later air-brake inspector.

ADDITION TO EDITORIAL STAFF.

IN view of the fact that "Canadian Machinery," commencing with the issue of January 30, 1913, will be published weekly, additional editorial assistance has been requisitioned in the person of Mr. Chas. W. Byers, whose photograph accompanies this memorandum.

He is a man of dual experience, having been trained as an engineer, yet becoming a successful journalist. He is an engineer by accident. Born in the village of Codnor in Derbyshire, near the beautiful Peak district of England, he passed through the public schools, and won a scholarship for three years at the Heanor Technical Schools. His course completed there, he expressed a wish to

go into the newspaper field, but his parents, knowing somewhat of the precarious nature of this calling, decided to fit him for other work, with the privilege of taking up journalism later if he wished. That is why Mr. Byers is with the MacLean Publishing Co. to-day.

He was sent to Nottingham University to study engineering under Professor William Robinson, author of "Gas and Oil Engines," with the understanding that if he could work his way through the full course, his people would pay his fees for the first year. He won two scholarships there, and graduated in 1906.

In June of that year, Mr. Byers sailed for the United States, where he obtained his first position with the Sullivan Machinery Co., manufacturers of min-



CHAS. W. BYERS,
Editorial Staff, "Canadian Machinery."

ing machinery, Claremont, N.H. After seven months of hard work in their shops, he was sent to operate their coal-cutting machines at Wind Rock, Tennessee. For eight months he worked in and around various mines in the Southern States, and returned north in the winter of 1907 to Cincinnati, Ohio, obtaining a post with Allis-Chalmers & Co. in their electrical shops.

In 1908 he visited his home in England, and, on returning, worked for several months in the shops of the Vermont Farm Machinery Co. at Bellows Falls, Vt. It was while here that the Semet-Solvay Process Co., with whom Mr. Byers had been associated in Ensley, Ala., made him an offer to go to Detroit, there to conduct tests on their coke ovens, with a view to taking charge of a battery of new ovens which they were erecting. He accepted the post, and was with the company the greater part of 1909.

As winter approached, a temptation came to enter the journalistic field. Up to this time, Mr. Byers had never seen the editorial sanctum. He came to Toronto, and not meeting with success on any of the city papers, went to Ottawa, where the "Evening Journal," seeing what an able writer he was, engaged him. His rise was rapid, and in a few months he was one of the "Journal's" most expert men. In August, 1910, the Hamilton "Spectator" offered him a larger salary to go there. He went, and made a name for himself in journalism.

In the summer of 1911 he went over to England for the coronation, and returned in September, just prior to the general election. Because of his knowledge of the French language, he was given a place on the editorial staff of the Montreal "Daily Witness," before long being appointed telegraph editor. Later he became assistant to the city editor.

After eighteen months with the "Witness," Mr. Byers accepted the position of associate editor on "Canadian Machinery," there to unite his knowledge of engineering with his ability to write.

On leaving the "Witness" early in December, Mr. Byers was presented with a handsome gift by the members of the editorial staff.

Prack & Perrine, Industrial Architects and Engineers, Hamilton, Ont., report a very busy and successful year, having designed and constructed new plants and extensions for the following concerns:—Brown, Boggs Co., Hamilton; Petrie Mfg. Co., Hamilton; Dominion Steel Castings Co., Hamilton; Canadian Westinghouse Co., Hamilton; International Harvester Co., Hamilton; Oliver Chilled Plow Co., Hamilton; The Mueller Co., Sarnia; Russell Motor Car Co., Toronto.

In addition to the above (all of which are metal working concerns), they have been responsible for the design and construction of buildings for several other large commercial firms, both in Canada and the United States.

Mr. Harry Davis, late of Geo. T. Fuery Co., of Birmingham, England, who has had sixteen years' patent experience in Europe, the United States, at Washington, and in Canada, will take charge of the English branch of the firm of patent solicitors, Messrs. Pigeon & Pigeon, of Montreal. It is due to Mr. Davis' personal merits and ability that he enters the firm, which will henceforth be known as Pigeon, Pigeon & Davis. Owing to the steady increase of business, Messrs. Pigeon & Pigeon have been compelled to entirely re-organize and increase their staff.



NEW GRAIN ELEVATOR FOR THE MONTREAL HARBOR COMMISSION.

THE marine traffic of the port of Montreal is second only to that of New York among all the ocean ports of North America. An important portion of the export traffic from Montreal is grain, which is, for the greater part, wheat from the Western Provinces of Canada.

Equipment prior to 1910.

Prior to 1910 the export grain handling equipment in Montreal Harbor consisted of a 1,000,000-bushel steel elevator, owned and operated by the Harbor Commissioners, and adapted for unloading lake and canal vessels, but not designed for extensive railway ear traffic; a 1,000,000-bushel steel elevator, owned and operated by the Montreal Warehousing Co. (a corporation subsidiary to the Grand Trunk Railway), equipped for the unloading of both railroad cars and inland vessels; two obsolete wooden elevators, owned by the Canadian Pacific Railway, and since torn down; and a small fleet of floating transfer elevators of varying age and efficiency.

The New Elevator and Its Purpose.

In the early part of 1910, the Harbor Commissioners determined on the immediate construction of a new grain elevator of the highest class to provide (a)—a rapid and efficient plant for the unloading of those railway cars for which the Grand Trunk elevator was not available; (b)—extensive additional capacity for quick unloading of inland vessels, which were often delayed for days in the harbor waiting to be unloaded; (c)—sufficient additional storage capacity so that merchants could hold grain at the exporting point when it became advantageous to do so, and to eliminate the necessity for direct, or almost direct transfer of inland cargoes to ocean vessels; (d)—facilities for shipping grain from the new elevator not only to the present vessel berths but to others being planned.

The Harbor Commissioners retained John S. Metcalf Co., Ltd., as their con-

structing engineers for the new elevator, and being the designers and builders of the Grand Trunk elevator in Montreal Harbor, and of the great export grain conveyor system belonging to the Commissioners, they were familiar with the development of the port and the details of the problems to be solved. The instructions were to provide the best in structure, equipment and efficiency, because the Commissioners were resolved that Montreal's export traffic in grain

should not suffer through lack of thorough facilities. In the summer of 1912 the elevator and a portion of the shipping conveyors were ready for the handling of ear grain; and the marine unloading equipment went into operation during October.

Even though the capacity of the new elevator was to be 1,772,000 bushels, it was found in 1911 that the storage room of the port would still be inadequate; and as the elevator was to have ma-



GEORGE WASHINGTON STEPHENS,
Late Chairman Montreal Harbor Commission.

achinery equipment suitable for taking care of several millions of bushels of storage capacity, the Commissioners ordered the capacity to be increased by 850,000 bushels, making the total capacity of the new work 2,622,000 bushels. The storage addition was ready for grain to fall. A description of the important features of the work follows, the general dimensions, including the storage addition, being 1,800 ft. long by 100 ft. wide and 220 ft. high to the tops of the leg towers.

The rail elevation is at high water level, but to provide for deep receiving pits it was necessary to carry a considerable portion of the excavation for the main elevator down to a depth of about 20 ft.; accordingly the entire area of the main building was excavated to low water level and 7,730 wooden piles were driven. The driving was found to be exceedingly difficult owing to the boulders, old cribs, etc., beneath the site. Two large drivers with No. 1 Warrington steam hammers were employed. On

moulded inserted type, with their tops about four feet below base of rail. Above them the foundation concrete was placed.

First Storey.

Four railroad tracks extend through the entire elevator. The bin openings are 22 ft. 6 in. above the tracks. The columns supporting the bins are of reinforced concrete, about 24 ft. centres, in general, each way. Some of these columns are as large as 6½ ft. by 5½ ft. They are surmounted by the heavy concrete girders supporting the bins. These main girders are 5 ft. deep and 6½ ft. wide. The first floor is of concrete except at hopper and grain openings, where steel gratings are employed. Curtain walls are of concrete, with a large

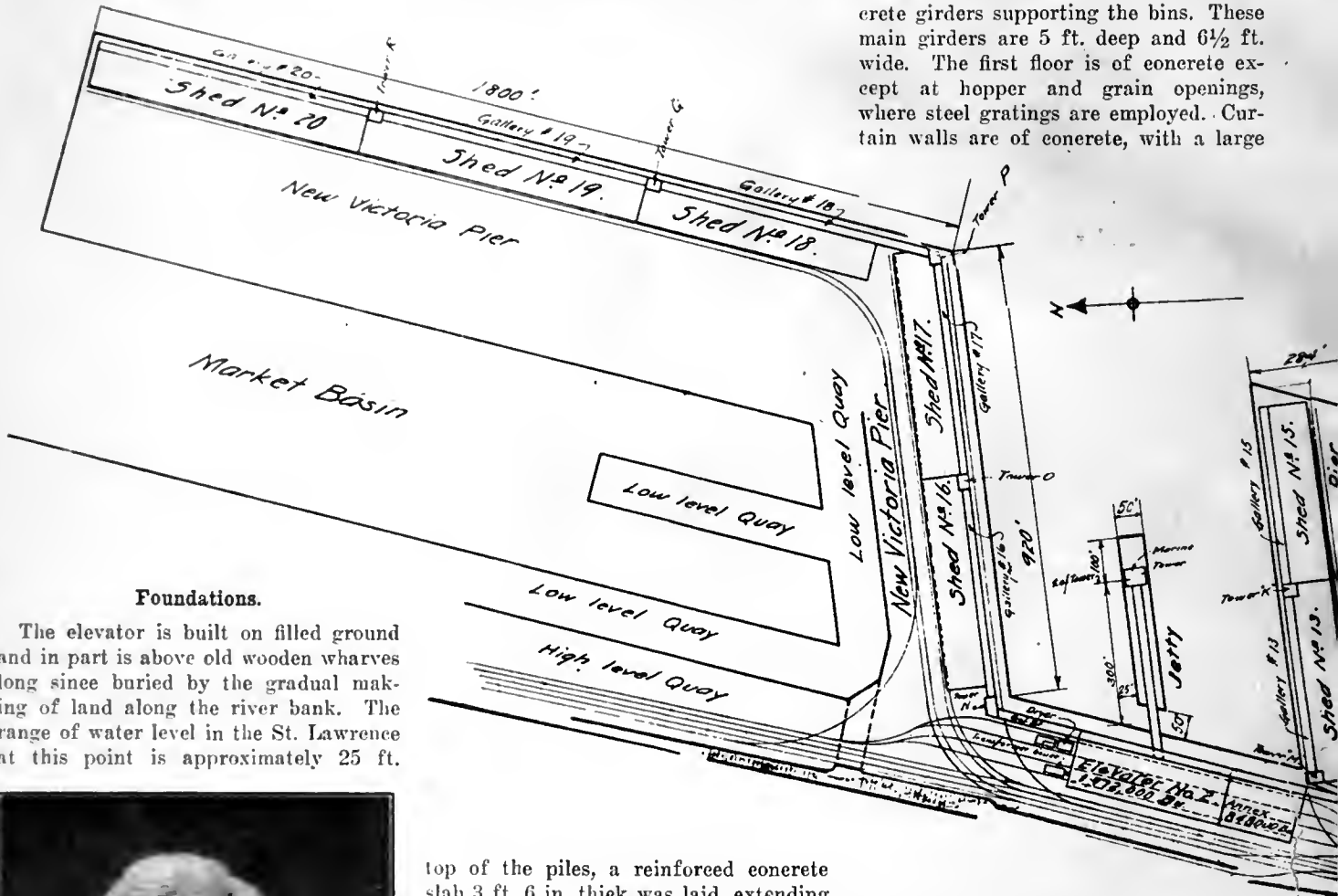

Foundations.

The elevator is built on filled ground and in part is above old wooden wharves long since buried by the gradual making of land along the river bank. The range of water level in the St. Lawrence at this point is approximately 25 ft.

top of the piles, a reinforced concrete slab 3 ft. 6 in. thick was laid, extending over the entire foundation area. An idea of the foundation problem may be gained when it is known that loads as high as 1,270 tons had to be carried on some of the columns. Concrete piers and walls were built on top of the foundation slab and carried up to the track level. The track girders are of reinforced concrete, except over the receiving pits, where they are of steel. Boot tanks and track hoppers are of steel.

The foundations of the 850,000-bushel storage addition were differently treated. As there were to be no elevator legs, and consequently no boot tanks, in this portion of the elevator, the deep excavation necessary for the main elevator was not required, consequently, 1,535 reinforced concrete piles were used. These were of the Simplex

area of fireproof windows. The track openings are closed by rolling steel doors.

Capacity and Construction of Bins.

The bins, of reinforced concrete, are rectangular in form, and 86 ft. deep. Bin walls are in general 8 in. thick. Bin capacities range from 6,800 bushels to 14,300 bushels, and the total number, exclusive of shipping bins, is 278. Along the water side of the elevator, the upper

Shipping Conveyor Gallery System
 12512 ft of Galleries = 2½ miles
 55953 ft of belt = 10½ ..
 207 dock spouts
 58 Trippers



F. W. COWIE, B.A. Sc. (McGill),
 Chief Engineer, Montreal Harbor Commission.

portion of each bin is used as a shipping bin. An intermediate concrete bin bottom is placed about mid height of

the storage addition being run in less than fourteen days, day and night work. The bin bottoms are of reinforced concrete, in part supported directly on the bin girders and in part suspended from them. Each bin opening is provided with a cast iron and steel revolving turnhead, with rack and pinion valve opened and closed from the floor below.

is placed on a jetty projecting into the neighboring slip. The tower is so placed



L. E. GEOFFRION,
Late Member Montreal Harbor Commission.



C. C. BALLANTYNE,
Late Member Montreal Harbor Commission.

Cupola.

The cupola construction is a remarkably fine example of reinforced concrete. Columns, girders, floor and roof beams, wind bracing, stairs, curtain walls, floors and roofs are all of concrete. In fact, only in the case of machinery supports has structural steel played any important part. The lower sides of floor and roof beams are cambered. Curtain walls are 2½ in. thick, supported at short intervals by concrete ribs connecting to the floor beams. Windows are of fire-proof type. Roof covering is of tar, felt and gravel, except on the leg towers, where the concrete is waterproofed and covering omitted.

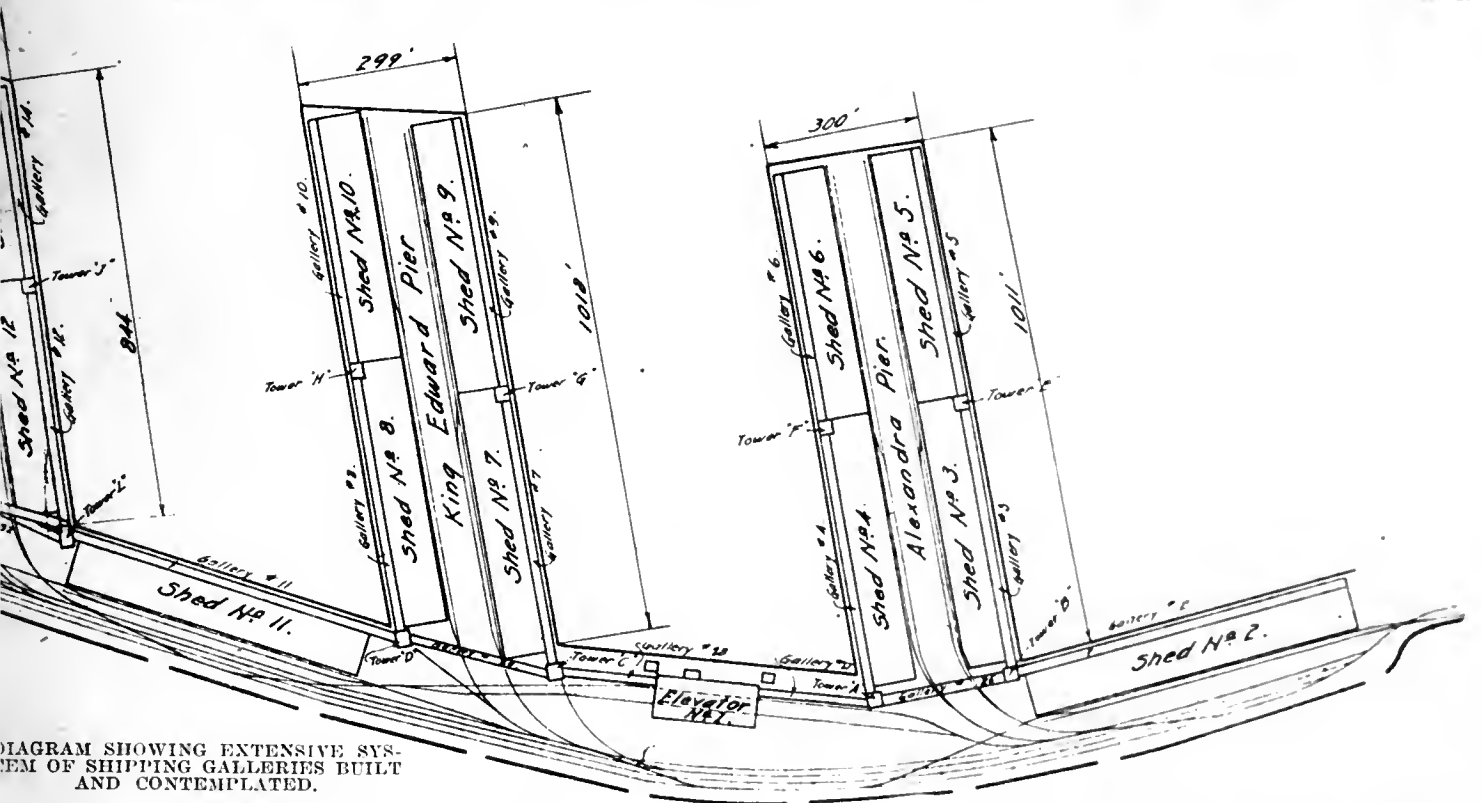

DIAGRAM SHOWING EXTENSIVE SYSTEM OF SHIPPING GALLERIES BUILT AND CONTEMPLATED.

the latter, the upper portion discharging to the shipping conveyors, and the lower portion being used as an ordinary storage bin.

The bins were constructed by the use of moving forms, which were raised by nuts working in jack castings attached to them, the nuts travelling on threaded rods set vertically in the concrete walls. Rapid progress was made in the building of the walls, the height of 86 ft. in

The cupola is 107 ft. high above the bin walls and 220 ft. above the base of rail. This means that there are very few, if any, higher reinforced concrete buildings in existence. Above the storage addition, the cupola is but two stories high, as the only machinery above those bins is the conveyors and spouts for filling the bins.

Marine Tower.

A marine tower for unloading boats

in order that two vessels may be unloaded simultaneously, one lying along each side of the jetty. The tower is 340 ft. from the elevator. It is built of structural steel, this material being adopted instead of concrete because it is expected that, in the event of the Georgian Bay Canal being built and 600-ft. vessels being brought to Montreal for unloading, it may be desired to extend the jetty farther and move the tower to

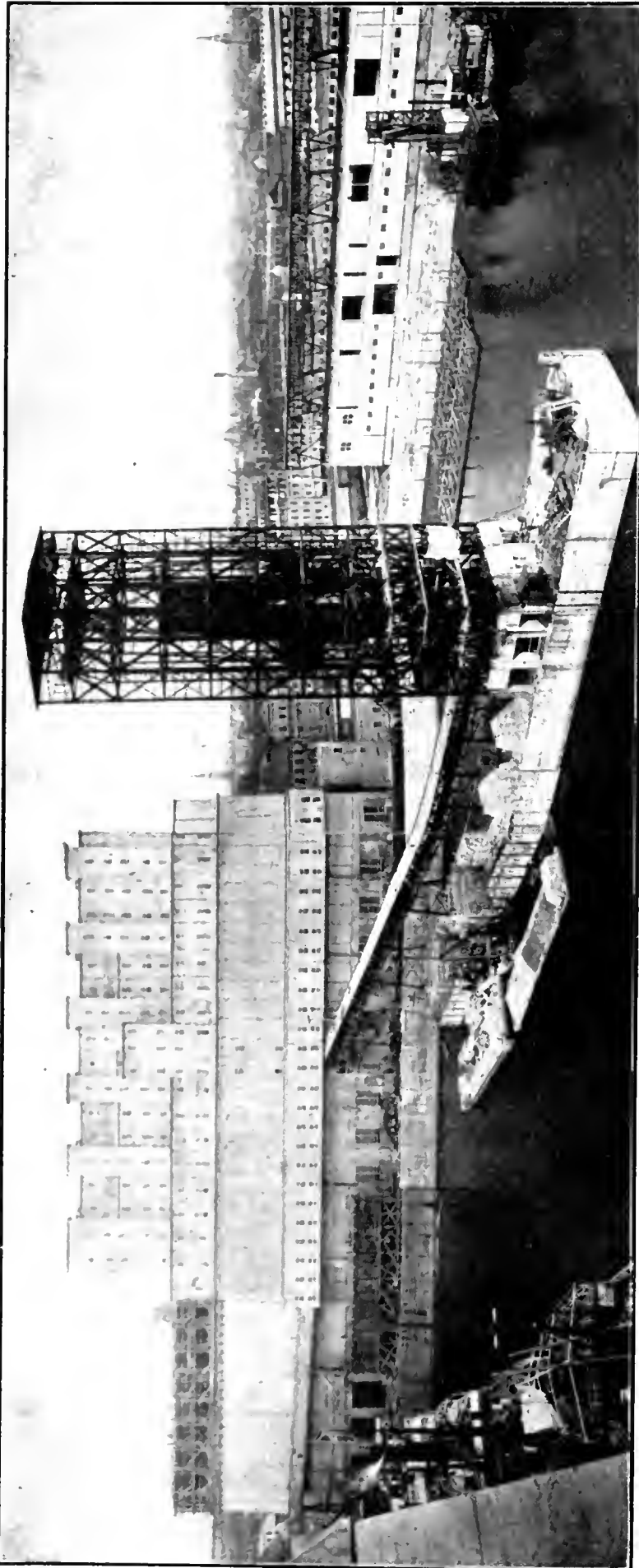

NEW GRAIN ELEVATOR FOR THE MONTREAL HARBOR COMMISSION. VIEW FROM JACQUES CARTIER PIER.

such a distance from shore that 600-ft. vessels may be unloaded without interference. As the shorter jetty is, however, better adapted to present congestion in the harbor, it has been adopted until such time as the increased size of lake boats coming to Montreal shall require its extension. A steel gallery runs from the marine tower to the elevator, and contains the conveyor belts for taking grain received by boat to the elevator.

Shipping Conveyor Galleries.

Study of the accompanying diagram will show the extensive system of shipping galleries built and contemplated. Those already built in connection with elevator No. 1 were two miles in extent. Those to be added in connection with elevator No. 2 will bring the total to 2½ miles, using 10 miles of rubber belt. All galleries are of steel with concrete floors and roofs and corrugated steel side-covering.

Miscellaneous Structures.

A reinforced concrete building is provided for a grain dryer and its boiler plant, and a similar structure for the transformers and switchboard.

Receiving Equipment from Cars.

There are 4 receiving tracks, 24 track hoppers and 12 receiving legs. Each leg is fed from two hoppers, one on either side, interlocking being used so that it is impossible for grain to reach the leg from more than one hopper at a time. Track hoppers are of large size, and a pair of power shovels is provided at each. Thus, the unloading of a car on one side of the leg is independent of that on the opposite side, and unloading from both cars may proceed simultaneously, as the legs are of sufficient capacity (12,000 bushels per hour each) to quickly elevate the contents of either hopper as soon as the elevation of the contents of the other has been completed.

The elevator will receive 240 cars in ten hours with the ordinary complement of men, and with extra men can better this in emergencies. Cars are handled by heavy carpullers using ¾-in. wire cable. Each receiving elevator discharges to a 2,500-bushel garner over a 120,000-lb. Fairbanks hopper scale, whence the carload is sent by spouts, or belt conveyors and spouts, to the desired bin.

Receiving Equipment from Boats.

The marine tower is equipped with two marine legs, each of 20,000 bushels hourly capacity on the dip. One leg operates on each side of the tower, so that two boats may be unloaded simultaneously. The grain from the legs is

weighed by two pairs of 6,000-lb. Fairbanks continuous automatic weighing machines. Complete ship shovel and clean up shovel apparatus, operated by

air, and the best of equipment for raising and lowering the legs, and adjusting them horizontally to the position of the boots, is provided. The marine legs are

of steel, 115 ft. long, to be set in a pulleys, and are the longest marine legs ever constructed.

Two 40-in. belt conveyors, 200 ft. long

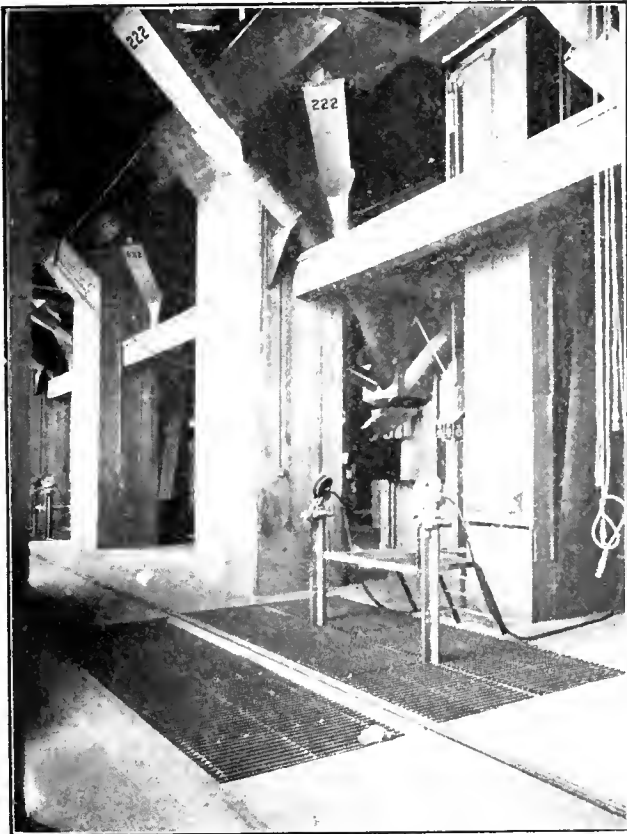

FIG. 3. FIRST FLOOR.

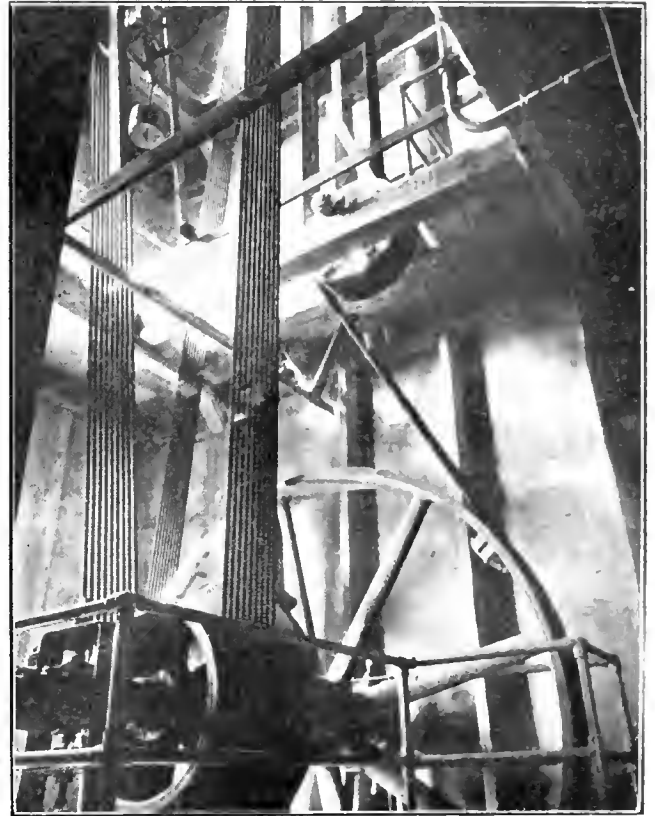

FIG. 9. DRIVE TO RECEIVING ELEVATOR LEG.



FIG. 4. DISTRIBUTING SPOUTS. STOREY OVER BINS.

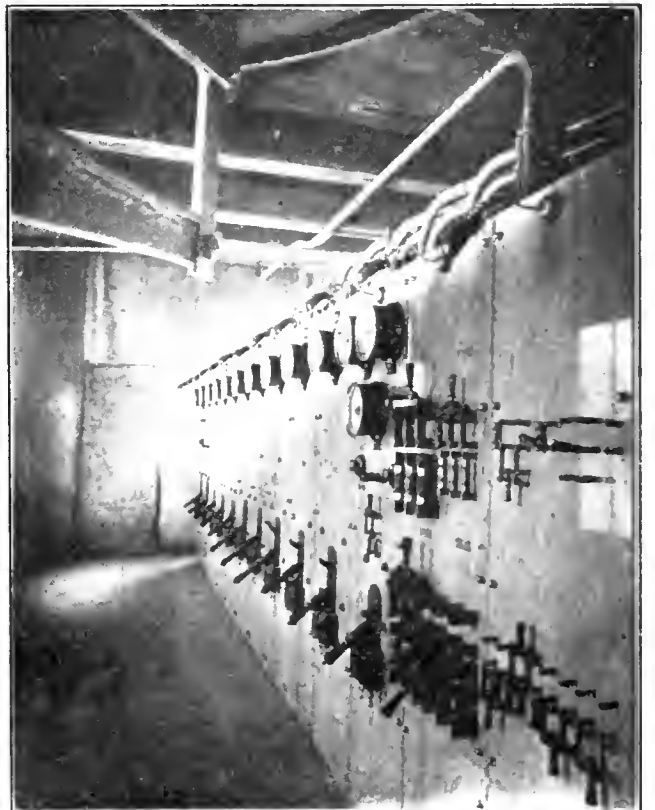

FIG. 11. MAIN SWITCHBOARD.

gram to the elevator, where two lofter legs elevate it to the eupola. There, a system of 40-in. belt conveyors distributes it to the double jointed spouts

of 16,000 bushels per hour. The total shipping capacity of elevator No. 2, starting with the shipping bins full, will be 90,000 bushels hourly for ten hours.

banks automatic weighing machines, each provided with automatic registers, printing devices and electrical counters in the weighman's office. As shipping to boats and receiving from boats are continuous operations, automatic scales are used for this work, but as it is necessary in receiving from cars to keep each car weight separate, hopper scales are employed for car receipts.

Drying.

A Hess drying plant with a capacity of 5,000 bushels per day is included in the equipment. This has a separate leg so that interference with the main receiving and shipping legs is avoided.

Power.

All power is supplied by electric motors of the induction type. In the elevator, marine tower and the new shipping galleries, the motors number 80, and total 4,680 h.p. An ingenious and efficient system of electric signals controls the operation of elevator legs and shipping conveyors. When the extent of the shipping system is remembered, and the interconnection of the two elevators, it will be seen that the signal system, particularly for shipping, must be instantaneous and sure. Its design was accomplished with credit.



FIG. 5. BELT CONVEYORS IN SECOND STOREY OVER BINS.

leading to the bins. The maximum hourly capacity for receiving from boats is 40,000 bushels.

Distributing.

Two reversible longitudinal conveyors in the eupola receive from the scales and distribute grain longitudinally.

Cleaning.

While Montreal is not a cleaning point, two large steel cleaning machines are provided for emergency cleaning and separating.

Shipping to Cars.

Four car-loading spouts are provided so that cars may be loaded if desired. This sometimes becomes necessary in order to get grain to a winter port farther east after the port of Montreal has closed.

Shipping to Ocean Vessels.

In connection with elevator No. 1, the shipping conveyors serve 14 vessel berths on King Edward, Alexandra and Jacques Cartier piers and the neighboring shore wharves. Five berths are being added on the new Victoria pier. The side shipping gallery of elevator No. 2 contains six shipping conveyors. Two will extend north to serve the Victoria pier, and four will run south to connect with the conveyors to the present 14 berths. It will be possible for either elevator to ship to any of the 19 berths. The shipping system of elevator No. 2 will be served by five shipping legs each with a capacity

of 16,000 bushels per hour. The total shipping capacity of elevator No. 2, starting with the shipping bins full, will be 90,000 bushels hourly for ten hours.



FIG. 2. FIRST FLOOR.

General.

The Harbor Commissioners' grain storage and shipping system will now consist of:—

Two grain elevators with two paring legs each, and a conveyor system by which grain can be delivered from either elevator to any of 19 steamer

berths. The elevators are of the same construction and are driven by a single motor. There is also a conveyor system of 3,620,000 lbs. capacity.

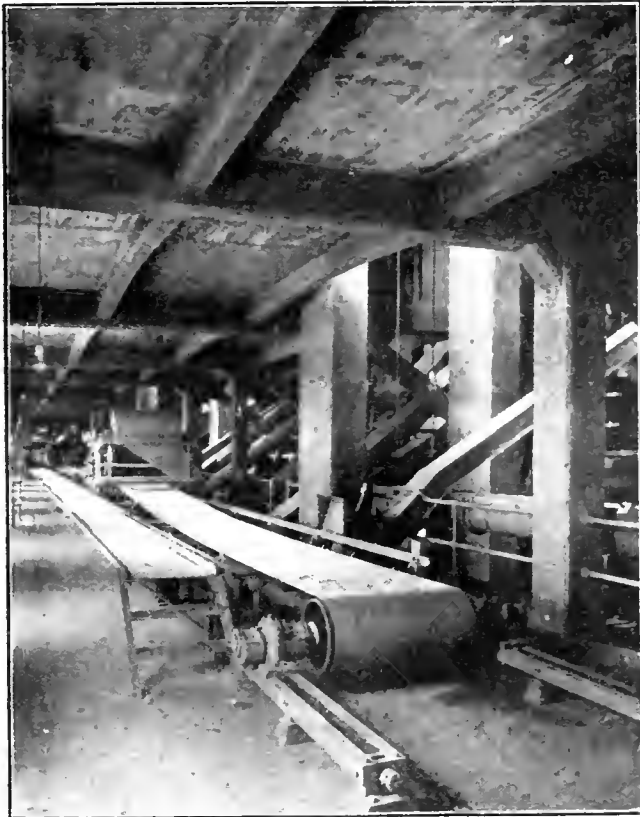

FIG. 6. BELT CONVEYORS IN SECOND STOREY OVER BINS.

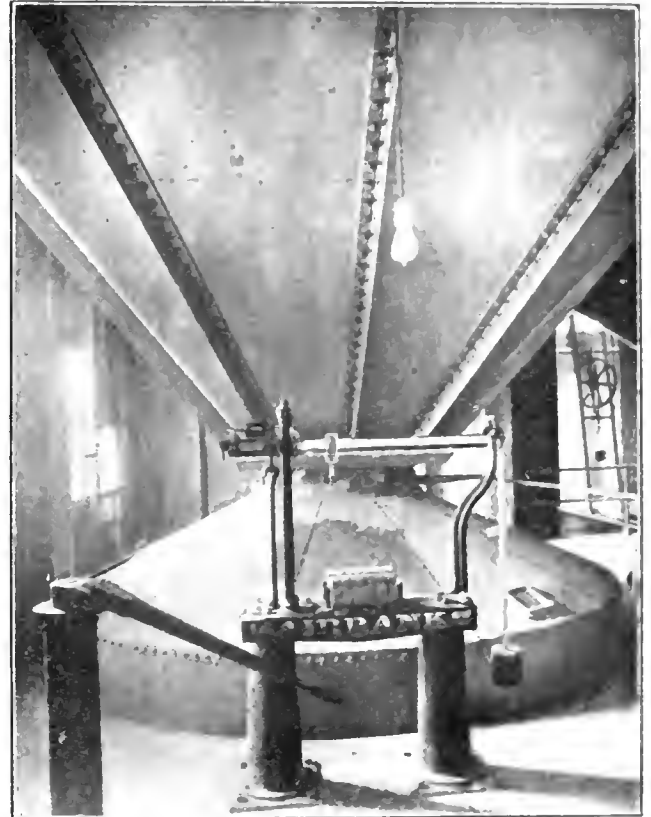

FIG. 7. 2,000 BUSHEL HOPPER SCALE.

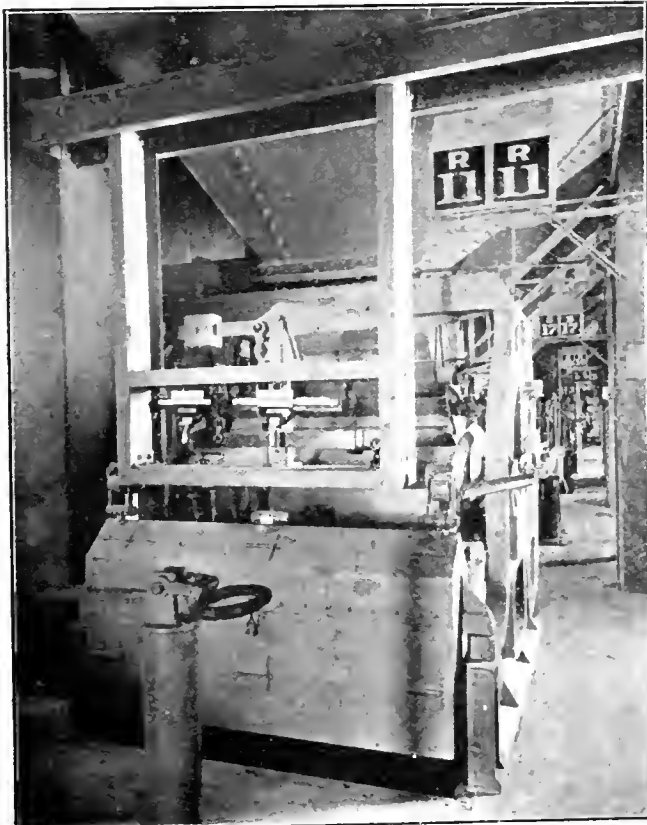

FIG. 8. AUTOMATIC WEIGHING MACHINE. 5,000 LBS. PER DRAFT

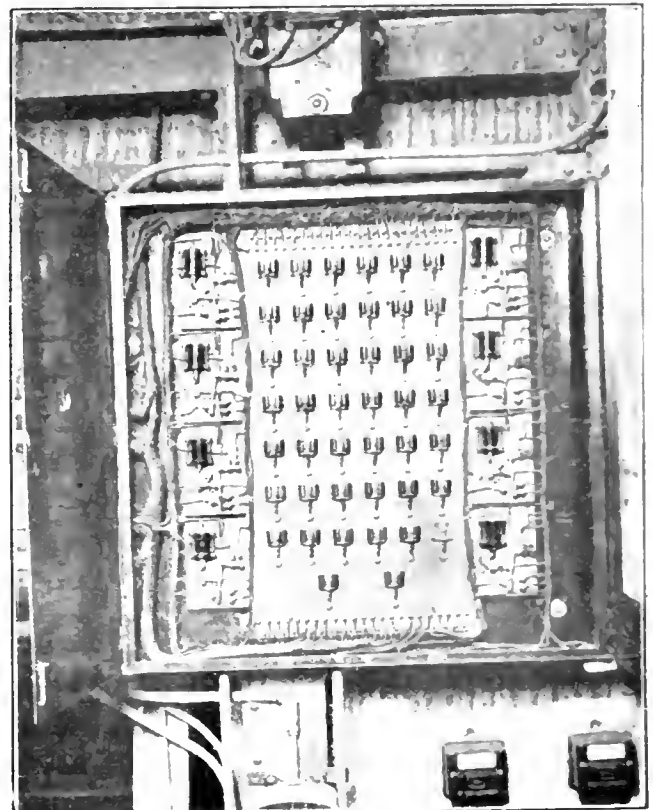

FIG. 12. RELAY PANEL FOR SIGNAL.

extensions for 3,790,000 bushels more; total 7,410,000. Grain may be received from cars at a rate of 33,000 bushels per hour, and at the same time from boats at a rate of 55,000 bushels per hour.

Grain can be shipped by conveyor system to ocean steamers at their regular berths at a rate of 150,000 bushels per hour, equal to 4,500 tons per hour. It is possible to deliver grain to five steamers at the same time at a rate of 30,000

Royal Tunnel, by the managing engineer of the new undertaking, Mr. S. P. Brown, who lectured before them recently.

"The designs for the Mount Royal Tunnel," said Mr. Brown, "are not yet completed, but it is probable that both twin tunnels and double track sections will be used, depending on the ground. Where the rock is of the proper character to permit it, the tunnel may be

being made in excavating the new tunnel; the engineer in chief appears to be satisfied. At present, he said, the average progress at the west end is 20 feet per day. In the east end, where the ground is rather bad, requiring timbering, and where no shooting is allowed at night, on account of public annoyance, the average progress for the last two months was 12 feet per day.

Possibilities of a Second Tunnel.

Will the future see the traffic in Montreal so heavy that a second tunnel, built above the present one, and carrying only rapid transit passengers, will be required? Mr. Brown evidently believes that it will. The grades and elevations are such, he said, that this tunnel passes under St. Catharine street with ample room for a future rapid transit subway above it, and the tracks are able to be carried level through the station and over the lower town on the proposed viaduct, where a yard for light and perishable freight is contemplated, to connect with the proposed Harbor Commissioners' elevator and a possible bridge across the St. Lawrence River.

Passenger Stations and Yards.

From the main passenger station, the speaker said, two tracks will run both east and west. The tunnel is something over three miles long, and the viaduct about one mile long. The passenger station yard will be about a quarter of a mile long, with platforms over 1,000 feet long, and an area of about nine acres. Local passenger stations will be situated down town and back of the mountain, as traffic demands. The main yard will be located near the Back River, where the electrical transfer yard will also be situated. There will also be a delivery yard in Mount Royal, and an elevated yard in the commercial part of Montreal.



THE TRANSCONA SHOPS OF THE N. T. R.

UNDOUBTEDLY the most important railway plant completed during 1912 was that of the National Transcontinental Railway at Transcona, Man., the locomotive shops of which were finally completed at the end of May. A complete illustrated description of such of the buildings as had then been erected, together with full details as to their equipment, was published in "CANADIAN MACHINERY" in July of last year, and to that article readers who wish full particulars are referred. A short part of it is here reproduced, with certain additional matter.

General Layout.

The shops are located on the prairie, six miles east of Winnipeg, and the



FIG. 10. TOP FLOOR. ELEVATOR HEADS AND DRIVES.

bushels per hour each, or it is possible to deliver to 10 steamers 15,000 bushels per hour each, at the same time. The present conveyor system comprises two miles of conveyor galleries and over eight miles of rubber belting, in addition to this there is under construction another half mile of gallery with two miles of rubber belting.

The constructing engineers for the Montreal Harbor Commissioners were the John S. Metcalf Co., Ltd., Montreal, under Mr. F. W. Cowie, chief engineer. This company were also the designers of the conveyor system in connection with elevator No. 1. It is easy to say that this building or that building is the best ever built, and that this elevator or that elevator can handle more grain than any other; the Harbor Commissioners responsible for the new work, Messrs. Stephens, Ballantyne and Geofrion, with Mr. David Seath, secretary, are content to let the elevator and accessories speak for themselves.



C.N.R. MOUNT ROYAL TUNNEL, MONTREAL.

THE members of the Canadian Railway Club, Montreal, were given some interesting details of the Mount

left unlined, although this cannot yet be determined. The minimum clearance has been limited to 16½ feet above the rail, but the standard tunnel clearance will be 17½ feet. In the twin tunnel, center walk ways will be provided at about the level of the coach floors, and cross passages will be cut through the dividing walls, at intervals, for communication between the two tubes. In the double track section, the two tracks will be separated by a duct bench, so that in case of derailment one train cannot block both tracks.

Electrification.

Just how the line will be electrified is another question that remains to be settled. Owing to the climatic conditions outside the tunnel, Mr. Brown said that it is improbable that a third rail will be used on the ground, therefore, the adoption of some form of trolley will become necessary. This means high voltage, either direct or alternating current. Great strides have been and are now being made in high voltage, direct current railway work, and until very careful and exhaustive studies have been completed, no decision can be made.

Excavation Progress.

With regard to the progress that is

whole area occupied by the buildings and tracks has been covered by a heavy gravel fill, 3 feet 6 inches deep, in order to raise the shop floors sufficiently above prairie level, to avoid all trouble from flooding in the spring. The whole property is $2\frac{1}{2}$ miles long by $\frac{1}{2}$ mile wide, and the total floor area of the shops when completed will be rather more than 17 acres. The plant has been designed to allow of a future extension of 100 per cent., and always keeping this in view, the grouping of the shops has been arranged as completely as possible in order to facilitate intercommunication in winter.

As in the majority of large railway plants of modern design, the various buildings are situated on either side of a spacious midway. The latter is 1,200 feet long, and runs north and south; a public road terminating it at the north end, while the locomotive roundhouse is located at the south end. It is served by a 10-ton electric traveling crane of 73 feet span, and by industrial and standard gauge tracks. The crane has a traveling speed of 400 feet per minute, enabling material to be rapidly handled between the various shops. It has two hoisting speeds of 15 and 40 feet per minute respectively. The motors, gears, etc., are covered in as a protection against the weather, and the operator's cage is electrically heated in winter. The height of the crane rails above level is 28 feet.

The power house stands about half way along the midway on the west side, thus occupying a central position for the distribution of power, light and heat. A track, running at right angles to the midway, immediately north of the power house and forge shop, forms, roughly speaking, the dividing line between the locomotive and the car departments; the latter lying to the north and the former to the south.

Extending the full length of the midway there is a 5 ft. x 6 ft. tunnel to accommodate the high and low pressure steam pipes and returns, together with the compressed air lines, etc. Tile conduits branch off to the various shops, and a short subway connects the tunnel with the power house. In this way the various pipe lines are distributed throughout the plant. An auxiliary chamber runs outside the tunnel and carries the electric cable conduits which are embedded in concrete, and at convenient intervals open into chambers accessible from the tunnel by means of doors.

Shop Lighting.

The general system of interior illumination is by Cooper-Hewitt A.C. mercury-vapor lamps of 700 C.P. each. Con-

nections are also provided for incandescent drop lights and extension cables. A 600-volt feeder runs the full length of the midway tunnel with sub-feeders to transformers outside each shop. These reduce pressure from 600 to 200 volts to suit the mercury-vapor and incandescent lights.

The midway and yards are lighted by Westinghouse series enclosed arc lamps. In the midway, these are carried from the crane runway, while in the yards they are supported by iron brackets on poles.

Details of Shop Construction, Foundations, etc.

Except in the case of the storehouse, stores platform and oil house, the buildings all have self-supporting steel frames standing on reinforced concrete footings. These are carried down 11 feet to the clay, and are of such a size that the pressure per square foot in no case exceeds 5,000 lbs. The walls are of concrete up to the window sills, and rest on wide concrete footings. Above the window sills, the walls are of white brick, carried up into a parapet wall on all four sides of the building and topped off with a coping of concrete. The roofs are mostly covered with tar felt and asphalt, coated with gravel. All windows are of $\frac{1}{8}$ -inch ribbed glass set in wooden sashes. The skylights are supported by $\frac{1}{4}$ x 3 inch steel ribs, and are of $\frac{3}{8}$ -inch wire glass, carried by rolled copper sheathing. Rainwater, etc., is collected on the roofs in copper receiving hoppers and brought down inside the buildings by wrought iron pipes to the sewers. The shop floors are of 3-inch planks spiked to 4 x 6 inch timbers, bedded in bituminous concrete.

The locomotive erecting and machine shop forms the largest building, it measuring 615 x 170 feet. It is divided into three bays, 70 ft., 60 ft., and 40 ft. wide, respectively. The 70 ft. bay forms the erecting shop and has twenty-five transverse locomotive pits served by a 120-ton overhead crane, below which there is a 10-ton messenger crane. The other two bays form the heavy and light machine shops, the 40 ft. bay having a gallery overhead on which are located the tin shop, brass finishing shop, air brake department and toilet rooms.

The boiler and tank shop measures 180 ft. by 205 ft., and the forge shop 260 x 100 ft. Both are very fine examples of what such shops should be and are splendidly fitted out in every way, the crane equipment being especially good.

The Power House.

The whole plant is operated, lighted and heated from its own power house situated at about the centre of the site.

This building is 150 x 110 ft. and is divided into the usual boiler house and engine room. Steam at 150 lbs. pressure is raised in eight water tube boilers, rated at 425 H.P. each. These are of the Erie City vertical tube type. Six are fitted with automatic stokers while the other two are hand fired and will eventually consume all shavings and waste lumber from the planing mill.

The engine room contains four A.C. steam driven generators, one D.C. ditto, a motor generator set and two independent steam driven exciter units, the nominal total capacity being 2,050 K.W.

The boiler feed pumps, fire pumps and other auxiliaries are accommodated in a pump pit at the foot of the wall dividing the engine room from the boiler house.

The Grey Iron Foundry.

This building is 200 ft. long by 130 ft. wide, with an annex 60 x 80 ft. for the cleaning department. The main bay is served by a 15-ton electric crane fitted with a 5-ton auxiliary hoist. One of the side bays of the shop is occupied by the toilet room and a small brass foundry, while the opposite bay accommodates the bench moulders, core makers and cupola room. A feature of the layout is that all storage bins are under cover, so that it is never necessary to go out into the open for raw material—a great advantage in severe weather.

The Car Department.

The car shops are now rapidly nearing completion and the equipment is understood to have been finally decided upon.

The largest building is the freight car shop which measures 600 x 200 ft. Here will be built both wooden and steel cars. The steel car bay is served by a 10-ton traveler and the wood car bay by a 20-ton traveler equipped with a 5-ton auxiliary hoist.

The wheel and machine shop is on the east side of the midway next to the forge shop, and is served by a 10-ton traveler. The machine tools here include three 42-inch ear wheel boring machines, two double axle lathes, two 42-inch coach wheel lathes, and other first-class equipment.

There are two coach shops arranged on either side of a transfer-table pit and parallel with the midway, across which the cars pass on their way to the paint shop. The latter is a spacious and well lighted building measuring 250 x 125 ft. Alongside it is the planing mill, 220x125 ft., equipped with the most modern wood-working machinery. All machinery is being supplied to very rigid specifications and will be of the same high-class as that already installed in the locomotive shops.



F. B. WARREN,
Chief Engineer of the Norton Griffiths Co., Ltd.
(Canada).



J. NORTON GRIFFITHS, M.P.,
President of the Norton Griffiths Co., Ltd.
(Canada).



W. BURTON STEWART
Managing Director, the Norton Griffiths Co.,
Ltd. (Canada.)

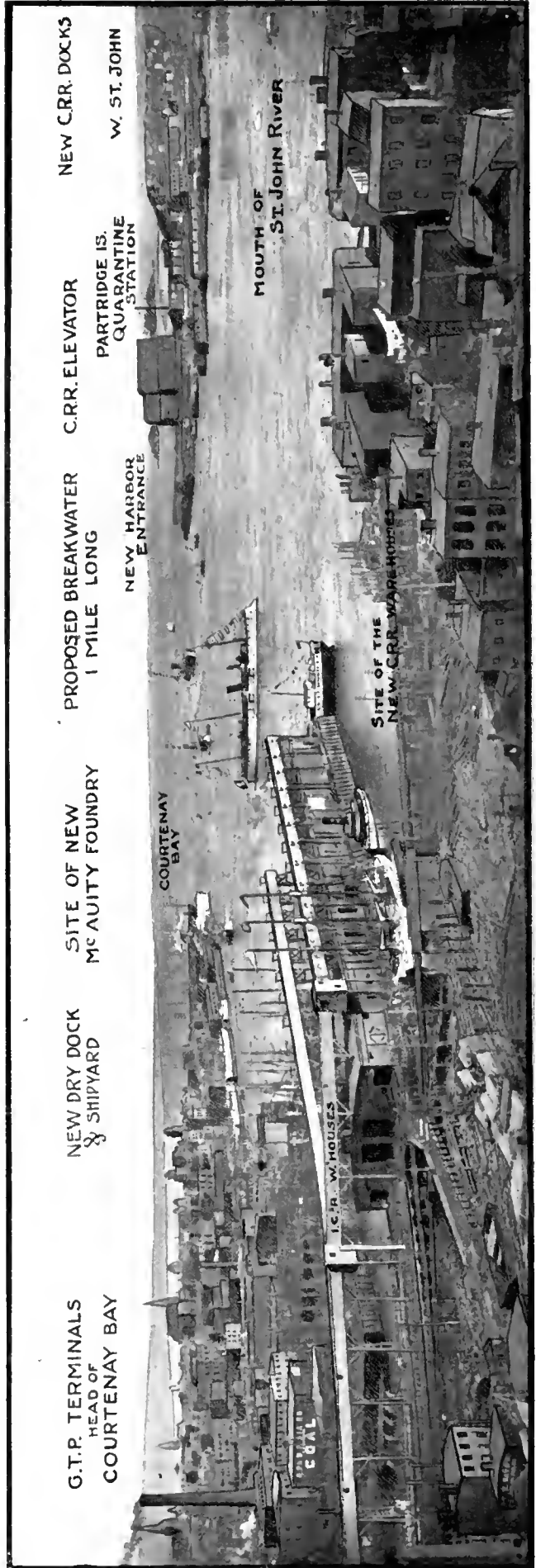

HARBOR OF ST. JOHN, N.B., AS IT WILL APPEAR WHEN THE DOCKS, WHARVES, BREAKWATER AND RAILROAD TERMINALS ARE COMPLETED.

Development of St. John, N.B., as an Ocean Port

By C.T.R.

It is abundantly evident that the next decade will witness the rise into prominence of this old-time city as the Dominion's leading port on the Atlantic Coast for winter freight and passenger service. Some there are who predict for it the flattering cognomen of "The Liverpool of Canada," and if railroad, dock and harbor developments are a criterion, we are disposed to agree with the prophecy.

THE Dominion Government, early in 1912, gave the contract for the construction at St. John, N.B., of two miles of docks, a dry dock and ship repairing plant, costing \$12,000,000, to the Norton Griffiths Co., Canada, Ltd.

future, the owners of one such having an agreement with the Norton Griffiths firm to come to St. John when the dock and harbor work is sufficiently advanced.

The C. P. R. already have terminal

Again, it is said that the C. N. R. is practically certain to make St. John its Atlantic terminus.

Three Transcontinentals.

This will give St. John three transcontinental railways emptying the products of Western Canada and the United States on her wharves. Add to the railways, the Interecolonial, covering a rich territory as far west as Montreal; the St. John Valley Railway, which will tap, with its branches, the heart of the rich farming land of New Brunswick, and the upper reaches of the St. John River, navigable 100 miles inland, with its four branches, each navigable for over fifty miles, bringing the products of

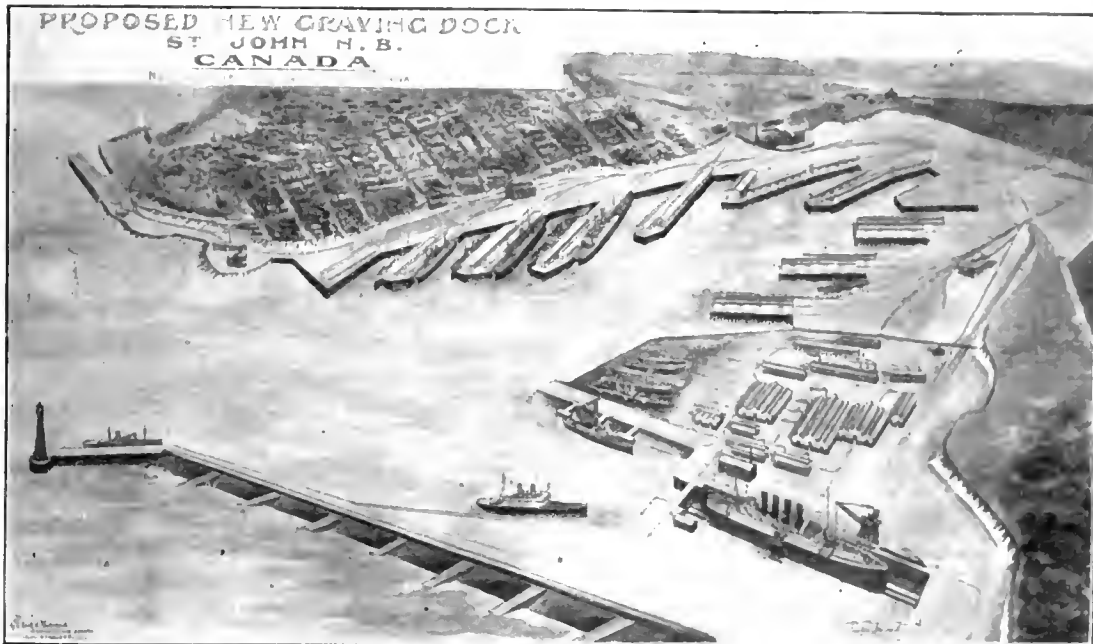

The Docks.

The two miles of docks—twenty-three in all—are the terminals of the Grand Trunk Pacific Railway Co. The dry dock, to be operated by its builders, will be one of the largest in the world, and there is also every possibility of a steel shipbuilding plant being established in the comparatively near

facilities at St. John, using seven docks, each capable of accommodating two vessels. These have, however, been found too small, and eleven more of like capacity are being built by the Government for the use of that railroad. In addition, the Interecolonial Railway have two docks, and there are two more at the Pettingill wharf, owned by the city.

the farms right to the ship's side; then it will be at once seen that there are immense possibilities ahead for this progressive port.

Comparison of Distances.

A comparison of distance of time and transit between Liverpool and Chicago by the New York and St. John routes

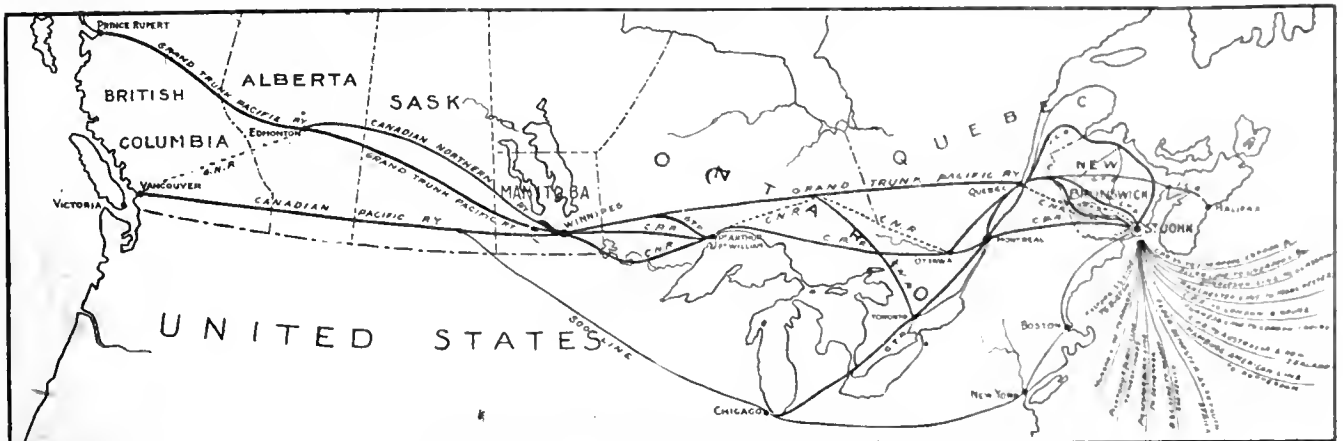

ST. JOHN, N.B., AS A DISTRIBUTING CENTRE.

the local freight yard tracks, are located the steamship wharves. There are two large sheds on a jetty pier of recent construction used by the Trans-Pacific steamship lines; also five sheds adjoining the longitudinal wharves used by the Seattle, Victoria, Alaska and other steamship lines of the Canadian Pacific Railway. Between the wharf sheds and the passenger tracks adjoining the passenger station, certain of the freight tracks serve the several sheds, and other tracks are used for drilling and storage. The yard tracks extend along the harbor front about $1\frac{1}{2}$ miles.

Detail of Improvements.

The general scheme embraces a passenger station and office building suitably located on available land immediately east of the present passenger station. There will be four passenger tracks with provision for more when required, separated by wide platforms, between the station and the present freight yard. The passenger tracks are to be raised about 5 feet above the present track level in order to reduce the difference in level between the street and the tracks to about 25 feet. To avoid an inconvenient grade crossing and delays to traffic between the city and steamship wharf, a bridge, on the line of Granville Street extended, is to pass over the passenger and freight tracks to the steamship pier, and connect directly with passenger accommodations on the pier. An incline is also to be built leading from the west side of this bridge to the wharf, giving access to the lower deck of the pier and freight sheds and the water front. Another viaduct over the tracks is to be built on the line of Burrard Street extended northerly, with an incline giving access to the present Trans-Pacific pier and other portions of the water front.

Railroad Station.

The main entrance of the passenger station will be on Cordova Street, with the main waiting room located centrally in the station on the street level. Ticket offices serving the several classes of railway and steamship passengers are located at one end of the waiting room, and the baggage checking room, lunch and dining room, parcel room, women's waiting room, men's smoking room, news booth, information booth, and other facilities are all placed immediately adjoining the main waiting room.

On the lower floors of the station are located the baggage rooms, express companies' space, immigrant rooms, supply rooms, and other station facilities not directly used by passengers. Stairways and lifts connect the two levels of the station, and also afford communication with the office floors above. A separate

footbridge is carried over the passenger tracks directly connected with the waiting room at one end and with stairways leading to the track level, giving access to platforms without crossing tracks at grade. The track platforms are 1,000 feet in length, and are to be covered with shelter sheds of the umbrella type. The platform adjoining the station will be used only for baggage, express and supplies.

Above the public rooms of the station building the space will be devoted to the general offices of the railway company. The interior arrangement of the office space will be adapted for a unit system of subdivision; that is, each panel will have heating and lighting facilities so that partitions may be placed or removed at will in order to provide for changes in arrangement of office accommodations which may be desired from time to time.

Steamship Station.

The proposed steamship station on the pier is a two-level building, the upper floor being devoted to the passenger business and offices, and the lower floor to freight, baggage and express. There will be double-level gangways on the west side of the pier, which will be used for the Victoria and Seattle service, the lower gangway being used for freight, and the upper for passengers; these gangways will be supported on floating pontoons to maintain the landing at a constant level with respect to the boats. On the passenger or upper level of the pier are provided waiting rooms, ticket offices, baggage checking room, customs office and other conveniences. Separate rooms are provided for outgoing and incoming passengers. Two tracks will be placed on the surface of the pier within the shed, and one track on the outside of the building for the direct handling of freight between cars and steamers.

The essence of the general design has been to secure easy lines of communication between the railway trains, steamers and the city. The traffic conditions at Vancouver are unusual as compared with other large terminals on account of the absence of suburban business. The aggregate number of trains is not large, but they are long and frequently are run in several sections and contain a number of classes of traffic.

The Westinghouse, Church, Kerr Co., Montreal, who prepared the plans, in conjunction with the C.P.R. officials, are also carrying out the constructional work.

If a separate and distinct trade school is found to be feasible and successful, it will require a practical teacher for the trade.

CANADA'S MERCHANT MARINE.

IN the calendar year 1911, there were built and registered in Canada 330 vessels, measuring 27,736 tons. During the year, 279 vessels were removed from the Dominion shipping register for various causes, and there were left on the books at the close of the year, 8,088 vessels of 770,446 tons. Of the total, 3,444 were steamers measuring 588,741 tons gross. The estimated value of all the vessels registered is \$23,113,380. Roughly, 41,500 persons find employment in connection with the industry. Of the 142 registered steamships of 1,000 tons or over, a large proportion is engaged in the St. Lawrence and the Great Lakes traffic. The Emperor heads the list in size with 7,031 tons gross register; the E. B. Osler coming next, with 6,787 tons gross. There are quite a number of 4,000 tons gross or over.

Previously the standing of the Provinces, according to the net tonnage of both sailing and steam vessels, was:— Ontario, 236,877 tons; Quebec, 193,682 tons; Nova Scotia, 142,631 tons; British Columbia, 122,264 tons; New Brunswick, 55,872 tons; Prince Edward Island, 9,683 tons; Manitoba, 6,373 tons; Yukon, 2,708 tons, and Saskatchewan, 356 tons. The high standing of British Columbia is due partly to the fact that many of the ships of the Canadian Pacific fleet are registered there. Thus, Vancouver is fourth in the list of ship-owning ports in Canada, with 45,573 tons to its credit, Victoria being second, with 65,350 tons; Toronto is third, with 57,513 tons, first place being held by Montreal with 145,274 tons.

SHEET METAL MERGER.

A MERGER involving \$1,500,000 has been effected by two of the largest sheet metal firms in Canada—the Metal Shingle and Siding Co., Ltd., Preston, Ont., and the A. B. Ormsby, Ltd., Toronto. The directors of the new concern are G. Dolph, Preston; A. B. Ormsby, Toronto; A. K. Campbell, Montreal; H. C. Randall, New York, and J. D. Murdoch, Simeoe. Factories of the company will be located in Toronto, Montreal, Winnipeg and Saskatoon. The plants in Winnipeg and Toronto will be known as the A. B. Ormsby, Ltd. The new company will manufacture important new lines of architectural sheet metal work and the plant for such work will be the largest of its kind in Toronto. Associated with the consolidated company will be the United Metal Products Co., of New York, the leading American manufacturers of interior fireproof lines. The head office of the company will be in Toronto.

Description of the Dominion's Latest Steel Foundry

Staff Article

The steel foundry just started up by the Dominion Steel Castings Co., Ltd., at Hamilton, Ont., is of particular interest from the fact that it makes steel by two distinct processes, one of which—the "Stock" converter process—is now being introduced into Canada for the first time. The establishment of this plant is another evidence of the growing demand for steel castings in every section of constructional and industrial engineering.

TO MEET the ever-increasing demand for steel castings, the Dominion Steel Castings Co., Ltd., was incorporated in July 1912, and forthwith commenced the erection at Hamilton, Ont., of an up-to-date plant, which is now practically completed. In fact, the first castings were turned out about six weeks ago, and the various buildings are now in a very much more advanced state than is indicated in our illustrations—the photographs from which the latter were made having been taken before the plant went into operation. Although the railways are still the largest purchasers of steel castings, there is a rapidly growing demand for smaller castings, notably from the automobile trade, and the Dominion Steel Castings Co. have laid themselves out to meet both requirements, being fully equipped for making large open hearth acid steel castings for locomotive and general machinery work, and also for turning out automobile and other light, intricate castings by the new "Stock" converter process. When in full operation the output of the foundry will be well over 1,000 tons per month,—a very appreciable addition to the total steel casting production of the country.

This is the first installation of a "Stock" converter in Canada and the

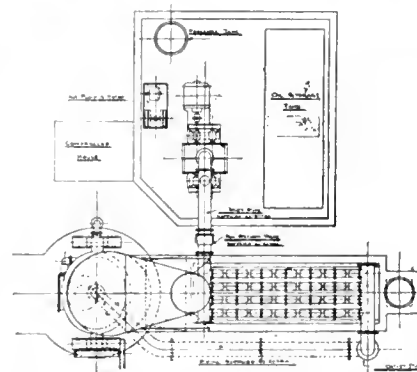
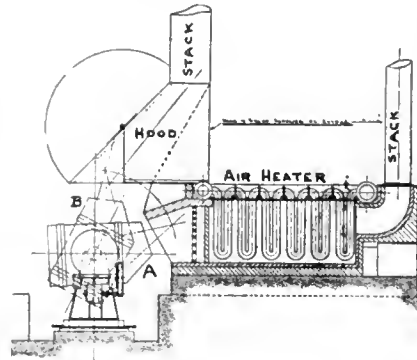

A TYPICAL "STOCK" CONVERTER INSTALLATION.

second, we believe, on the American continent; so that a brief description of its leading features will be of interest.

The process was invented in England about four years ago and has there met with considerable success. The British Admiralty have investigated the process and have given it their approval; and as that body's specifications are perhaps the most stringent to be met with anywhere, this speaks volumes for the merits of the apparatus.

The process was first introduced to overcome the difficulty, generally experienced with the open hearth furnace, of economically making small castings in limited numbers. In the open hearth furnace steel can only be produced at a reasonable cost in comparatively large quantities; but the "Stock" converter will turn out castings economically in 2-ton, 1-ton or even smaller lots. An important feature in connection with it is that no separate cupola is required for first melting the charge. On the contrary the pig and scrap are charged cold directly into the converter and there melted by crude oil. The employment of this fuel has several advantages, not the least of which is the prevention of any possibility of impurities being introduced into the metal during melting.

A view of a "Stock" converter being charged is seen on this page, while the line cut above it, shows the general arrangement of a typical installation. The vessel is lined with ordinary silica firebrick and is oval in section, in order that a large surface of metal may be exposed to the action of the flame. Besides being fitted with trunnions supported in roller bearings, the converter is also mounted on a turntable and can be turned through a complete circle in a horizontal plane. When the converter has been charged, the turntable is swung round through an angle of 90 degrees into the melting position, as seen at (A). From the line cut, it will be noted that the nose of the converter is pointing towards an economiser or air heater, which consists of a nest of cast iron pipes of special design, contained in a chamber lined with fire brick. Into these pipes cold air is delivered by the blower, and passes through the heater, the discharge from which is coupled to

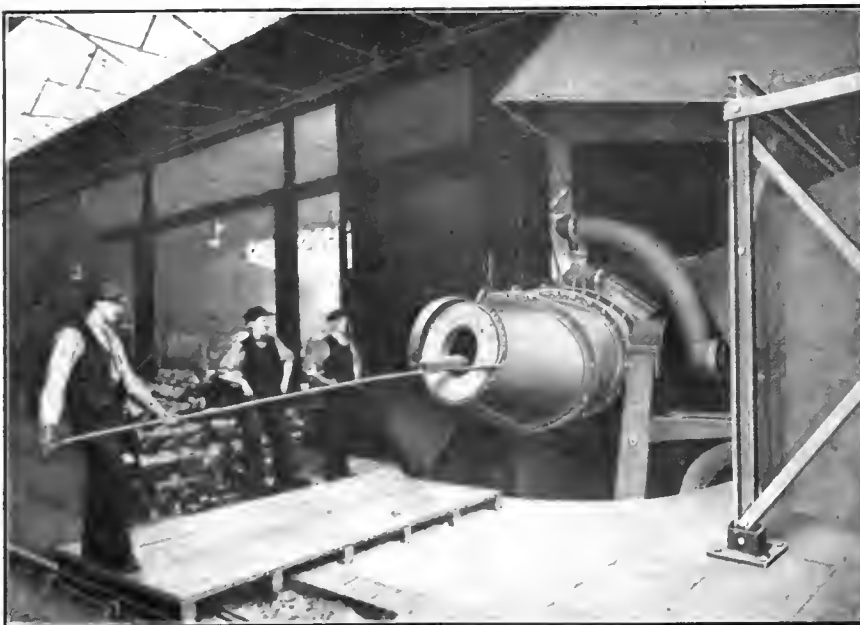

CHARGING A "STOCK" OIL-FIRED CONVERTER.

the converter through a central pipe. The air leaves the heater at about 12 ozs. pressure, and at a temperature of some 800 degrees F. Very perfect combustion is thus obtained with a resulting economy of fuel. The hot gases of combustion are drawn through the air heater by the stack seen at the end of of the latter. With a 3-ton converter, the charge can be melted in about 1½ hours.

As soon as the metal is melted, the oil supply is cut off and the burners are removed from the blast box—this being a simple operation occupying a couple of minutes. The vessel is then tilted up, as shown at (B), and the conversion to steel continued in the usual way; the blast, which for melting was at about 12 oz. pressure, being increased to 3 lbs. or 4 lbs. Blowing continues

for about 20 minutes, at the end of which period the converter is again brought to the charging position, and the necessary additions of ferro-silicon or ferro-manganese are made. The metal is afterwards poured into a ladle in the usual way. The special advantages of this system of making steel, not already mentioned above, may be classified as follows:—

1.—The amount of space occupied is comparatively small, due to the fact that the converter can be turned in a horizontal plane, enabling the arrangements for charging, blowing and pouring to be provided in the most convenient positions.

2.—The loss of iron resulting from cupola melting is saved.

3.—The high temperature of the melted charge allows the use of pig irons

low in silicon, or the use of a higher percentage of scrap.

4.—The metal is in such a state of extreme fluidity that it is possible to make the most difficult and intricate castings. The last mentioned feature is well demonstrated by the illustration at foot of page 24, which shows a number of castings produced from steel made by this process. The goblets here seen are only 1-16 inch. in thickness and the radiator bracket in the foreground is only 3-16 inch. thick.

To give some idea of the scale of the illustration, it may be mentioned that this bracket is 32 inches long, the holes in it being 2 inches in diameter, and the outer flange ¼ inch in thickness. The fine tracery in the ornamental plaques in the background is also worthy of notice. All the castings shown were made from mild steel of 0.2 carbon. This illustration is merely introduced to show the possibilities of the process. The examples were not produced by the Dominion Steel Castings Company, who at present writing have not yet got their "Stock" converter completely installed. When it is in operation the company feel confident that no steel casting will be too intricate or difficult for them to make. They are also equally well prepared for turning out the heavier acid open hearth locomotive and general castings, the equipment for this work being of a high order as will presently appear.

Reverting for a moment to the "Stock" converter, it may be mentioned that such well-known firms in England as the Darlington Forge Co.; Sir Armstrong, Whitworth & Co.; the Wolsley Co.; the Daimler Motor Car Co.; and many other have installed these converters; in fact it is said that the Daimler Co. produce the whole of their automobile castings by this process.

Layout of the Plant.

The plant is situated on a site of 10 acres at the east end of the city about 2½ miles from the City Hall, and in the centre of the manufacturers' annex. A ground plan is shown herewith from which it will be seen that there are at present six buildings, viz.: power house, foundry, finishing department, store room and laboratory, pattern shop, and pattern storage building.

The stock yard, foundry and finishing department all run east and west parallel with one side of the property, and the successive stages of manufacture carry the product across the shops from south to north in a line at right angles to the main buildings. A railway siding runs across the east end of the site and thus serves both for the receipt of raw material and the shipment of finished castings.

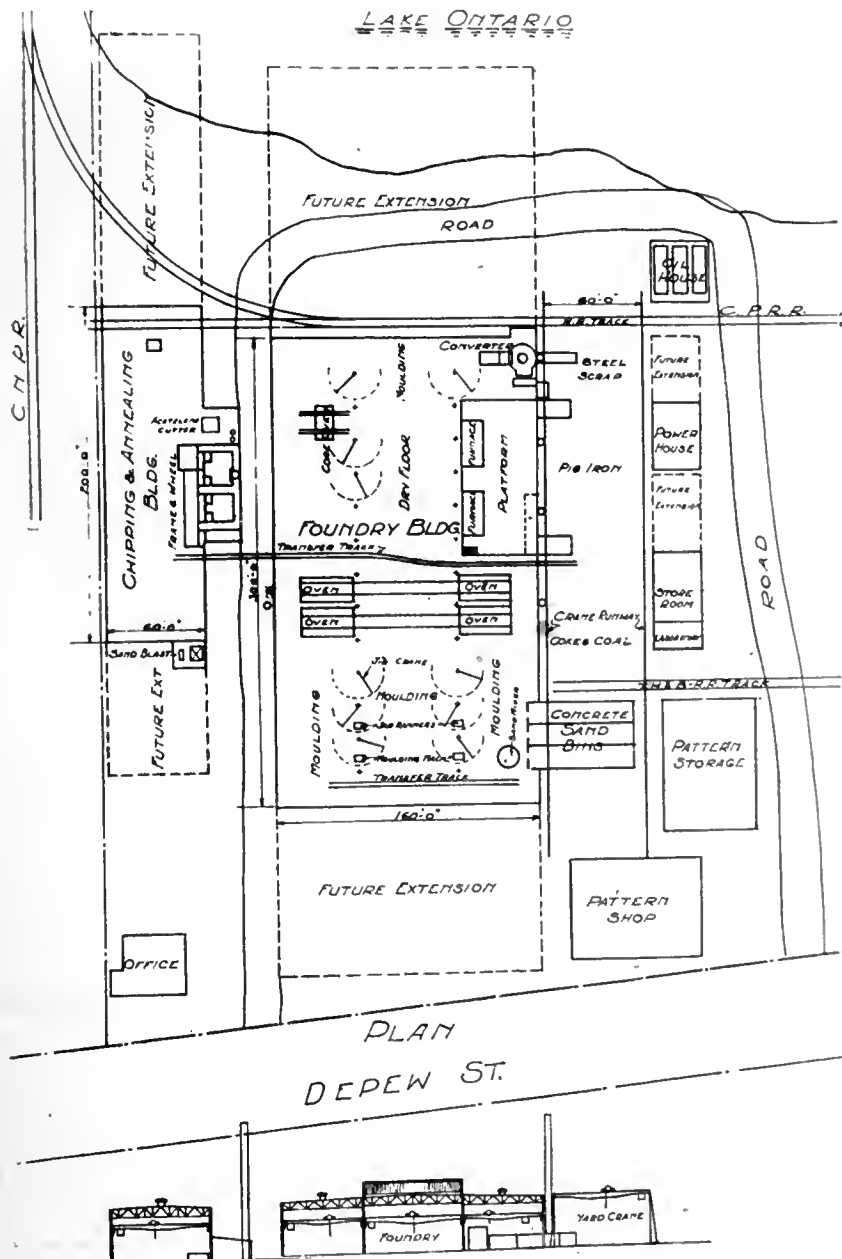

LAYOUT AND CROSS-SECTION OF PLANT OF DOMINION STEEL CASTING CO.

Construction of Buildings.

The main buildings have steel frames, the columns being supported on concrete piers. Concrete side walls extend to a height of 6 ft., above which, there is a continuous steel sash reaching practically to the roofs. The latter are of 2½ inch reinforced concrete, supported on steel trusses and covered with "Neponset" roofing material.

The foundry has six monitors running across at right angles to the length of

50 ft., and a centre 60 ft. bay. Each of the side bays is served by a 10-ton Cleveland crane and the main bay by a 25-ton crane of the same make. The 60 ft. bay will be further equipped in the near future with a second crane. This will be of 30 tons capacity with an auxiliary 5-ton hoist.

The south 50-ft. bay is occupied by the sand grinding pans, the drying ovens, two open-hearth furnaces and the "Stock" converter. The 60 ft. bay

The sand mills are located in the south-west corner of the foundry adjacent to the sand bins in order to reduce handling to a minimum. They are of the old-fashioned roll type generally used in steel foundries and are motor-driven. They were supplied by Phillipps and Maclaren, Pittsburg.

Melting Equipment.

The melting equipment consists of two 20-ton acid open-hearth furnaces and a 2-ton "Stock" converter as previously mentioned. The open-hearth furnaces were designed and built by Wm. Swindell and Brothers, Pittsburg. They are equipped for burning fuel oil and are set up about 8 ft. above the foundry floor, thus rendering the checker work easily accessible and enabling tapping to be done without the use of a pit for the ladle. The melting platform is of structural steel and extends the full width of the 50 ft. bay. It is of substantial construction as the company intend to instal a charging machine of the overhead type at an early date. The platform extends out about 20 ft. into the stock yard, and is provided with a narrow gauge track on which charging trucks run. The latter are run out to the end of the extension and there loaded up by the stock yard traveler.

Drying and Core Ovens.

The company intend to go in principally for dry sand work, the foundry being equipped with four drying ovens, 15 ft. long by 40 ft. inside, fired by coke from a pit running along one side. The flues have been specially placed to give a very uniform distribution of heat. The ovens are served by the interesting type of truck shown on page 24. The



MAIN BAY OF FOUNDRY WITH DRYING OVENS AND NO. 1 OPEN HEARTH FURNACE UNDER CONSTRUCTION.

the building, resulting in excellent natural lighting over the whole shop. The whole of the steel work was manufactured and erected by the Hamilton Bridge Works Company.

The stock yard for storage of pig iron, steel scrap, coke, etc., runs parallel with the south wall of the foundry and is served by a 10-ton Northern crane fitted with a lifting magnet. The crane runway is 350 ft. long by 60 ft. span. At its west end are the sand bins. The sand-handling, storage and grinding facilities have been carefully designed with a view to the maximum of efficiency and economy. The sand is received on the track at the east end of the plant and is unloaded from the cars into buckets. These are carried by the stock yard traveler to the sand storage bins and there dumped through openings in the roof. The sand storage building is of concrete, 65x40 ft., and runs at right angles to the foundry, near its west end.

The Foundry.

The foundry is 300 ft. long by 160 ft. wide, the two end walls being merely of a temporary nature to allow of future extensions. The building is divided into three bays, there being two side bays of

forms the heavy work floor and main easting floor, the bench molders and core departments being in the north 50 ft. bay.



ANNEALING FURNACE FIRING PIT.

tracks consist of two sets of rails carrying a number of 8-inch cast iron balls. The truck has bolted to its under side four similar rails, the whole forming a "cage" for the "ball-bearing." The balls are not attached to the truck in any way, but are distributed at intervals along the whole length of the track, both inside and outside the ovens. When a mold has been placed on a truck, the latter is merely rolled forward on the balls and thus enters the oven.

At the plant under consideration, however, the annealing furnaces are of the most modern description, and have been carefully designed to give an even distribution of heat. There is a special furnace for annealing locomotive frames and similar large castings. This is 40 ft. long by 5 ft. deep by 6 ft. wide, and is fired by four fire holes along one side. Heat from the fires passes over the castings and enters downtakes in the floor, passing thence through flues un-

The furnace for annealing locomotive driving wheel centres and similar castings is also of the open top type and measures 7 ft. by 7 ft. In addition to these, there is a 4 ft. by 6 ft. furnace for smaller castings. All three are fired by coal.

The equipment so far installed in the finishing department for removing gates, risers, etc., consists of a heavy shaper and three cold saws; these are all motor-driven. In addition, there are two 20-inch double floor grinders and three swing frame grinders, all by the Ford-Smith Machine Co., Hamilton. These are driven from a line shaft along the north side of the shop. The swing frame grinders are fitted with bearings at their upper end and swing on the revolving line shaft.

For straightening castings, the company have designed a special press consisting of a bed plate 20 ft. long with a movable housing or frame. The latter is equipped with a hydraulic ram having a travel the full length of the bed plate, which enables pressure to be applied to any part of the casting.

Further equipment in the finishing department includes an oxy-acetylene outfit for cutting off large gates and risers, and a sand blast apparatus, the latter being housed outside the main building.

The Power House.

Power is purchased from the Cataract Power Company at 2,200 volts pressure. This is reduced by two 100 kw. transformers in the power house to 220 volts for the arc lighting and the motors driving the sand mills, pattern shop, etc. For operating the cranes and stock yard magnet, there is a 150 h.p. motor generator set delivering direct current at 220 volts. The motor is direct-coupled to



ANNEALING ROOM, SHOWING FURNACES IN COURSE OF ERECTION.

The core ovens are located in the middle of the core room, and are served by trucks from either side in such a manner as to make their operation continuous. They are fired by coke and are conveniently situated to serve both the main floor and the bench molders.

The foundry is piped for compressed air and will eventually be fully equipped with jar ramming and other molding machines, as the work may require.

The Annealing and Finishing Department.

These are in a separate building measuring 60 ft. by 200 ft. It runs parallel to the foundry with which it is connected by a narrow gauge transfer track and a standard gauge shipping track. The building has a height to the roof truss chords of 28 ft., and is served throughout its length by a 10-ton Northern crane. There are three annealing furnaces, all castings made by the company being carefully annealed. While most steel foundries are now giving this matter careful attention, the ovens used are often mere plain brick chambers in which but little attention has been given to the circulation of the heat, with the result that a uniform annealing of the castings is impossible.

derneath the furnace bottom to a steel stack. In this way the heat is made to pass completely around the castings. The furnace is of the open top type. The covers are sectional, lined with fire brick, and are removed by the overhead traveling crane.



CHARGING PLATFORM, NO. 1 OPEN HEARTH FURNACE. IN THE BACKGROUND IS SEEN ONE OF THE DRYING OVENS UNDER CONSTRUCTION.

the generator and is of the induction type, taking current at 2,200 volts.

Compressed air is supplied by an Ingersoll-Rand two stage compressor having a capacity of 700 cubic feet of free air per minute. This is operated by a short belt drive from a Westinghouse 2,200-volt induction motor. For providing blast to the "Stock" converter there is a Root's blower driven by a Westinghouse 100 H.P. variable speed 220-volt motor.

Further equipment in the power house includes the oil distributing pump and pressure tank. Crude oil is stored in three underground steel tanks of 12,000 gallons capacity each. These are located near the track at east end of the plant and are filled by gravity from tank cars. From these tanks, the oil is drawn by a small vertical triplex pump in the power house which delivers the oil to a pressure tank. Compressed air is piped to this tank, the oil being thus distributed to the open hearth furnaces and the converter. The pressure tank is fitted with a coil through which steam is passed to reduce the viscosity of the oil. A small boiler in the store room supplies the steam for this purpose. A standby boiler serves as a standby for the oil should the electric pumps render the air compressor inoperative. It has also been taken to the oil supply to the triplex pump, men-



MAIN BAY OF FOUNDRY

ten from a short 1-h.p. motor. Both the building, resulting in side upon natural lighting over the whole shafting being whole of the steel work was being installed and erected by the Hamilton Works Company.

The stock yard for storage of iron, steel scrap, coke, etc., runs parallel with the south wall of the foundry. It is served by a 10-ton Northern crane fitted with a lifting magnet. The crane runway is 380 ft. long by 60 ft. span. At its west end are the sand bins. The sand-handling, storage and grinding facilities have been carefully designed with a view to the maximum of efficiency and economy. The sand is received on the track at the east end of the plant and is unloaded from the cars into buckets. These are carried by the stock yard traveler to the sand storage bins and there dumped through openings in the roof. The sand storage building is of concrete, 65x40 ft., and runs at right angles to the foundry, near its west end.

The Foundry.

The foundry is 300 ft. long by 160 ft. wide, the two end walls being merely of a temporary nature to allow of future extensions. The building is divided into three bays, there being two side bays of

a small steam turbine alongside the electric motor. Both have the same size of pulley and run at approximately the same speed. Should current fail, the belt will simply be transferred from the motor to the turbine, the pulley on the countershaft above being much wider than the belt in order to allow of this. The Waterous Engine Works Co., Ltd.,

is well laid out for the making of large or small patterns and is well supplied with the usual wood-working machinery mostly supplied by the Berlin Machine Works and the Canada Machinery Corporation.

General.

An up-to-date laboratory has just been completed and is fully equipped

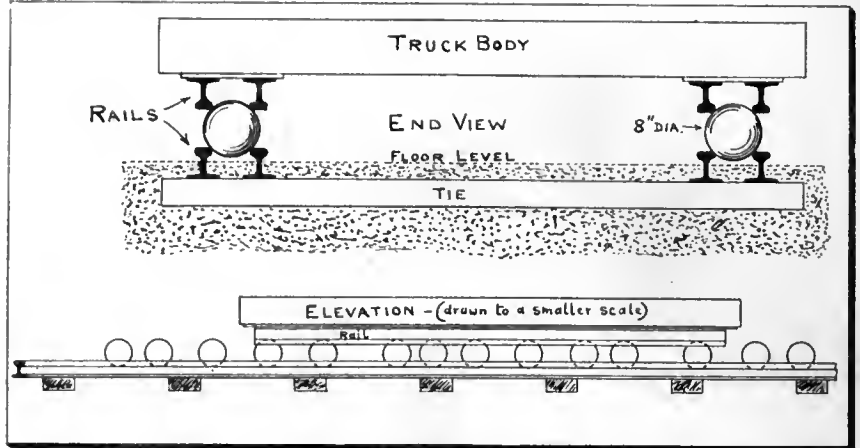

NOVEL FORM OF DRIVING OVEN TRUCK.

Brantford, Ont., are the makers of the triplex pump.

Pattern Shop.

The pattern shop is located at the west end of the site, and measures 60 ft. by 80 ft. It has concrete walls for a height of 6 ft., and continuous steel sash above this. This sash extends round all four sides of the building, which is further provided with a saw tooth roof having a northern aspect. The result is a shop that for good natural lighting would be hard to beat. It

for making complete chemical and physical tests of the steels produced.

The capital of the company is \$500,000 and the executive officers are:—

C. W. Sherman, President and General Manager.

Allan Mosher, Vice-President.

Austin C. Taylor, Secretary-Treasurer.

In a few weeks from now, the plant will be in full operation and producing open hearth and converter castings at the rate of over 12,000 tons per annum.



"STOCK" OIL-FIRED CONVERTER.

Dodge Manufacturing Company's Plant, Toronto, Ont.

Staff Article

In these days of specialization and standardized products, it is difficult to realize that only 35 years ago there was not a single dealer in pulleys doing business, owing to the fact that it was utterly impracticable to carry the enormous stocks that would at that time have been necessary in order to fill an order for a pulley of any diameter and width to suit any size of shaft. The coming of the modern pulley, with interchangeable bushings, completely revolutionized the business and it is now possible to meet any demand from a comparatively small stock.

IT IS no exaggeration to say that the name "Dodge" is known wherever transmission machinery is used, not only in Canada, but also in Great Britain, Australia, New Zealand and every other part of the British Empire. The Dodge Manufacturing Company started business in Toronto in April, 1886, at which date they commenced the manufacture in Canada of the well-known Dodge patent wood split pulley, which rapidly became a general favorite.

As time went on, the business was gradually extended to other branches of the power transmission business, until now the Dodge Mfg. Co. is by far the largest concern of its kind in Canada. The following partial list of lines manufactured will give some idea of the wide field covered:—Shafting, hangers, pillow blocks, couplings, collars, wood split pulleys, solid and split cast iron pulleys, friction clutches, spiral conveyors, chains and sprockets, rope and wire cable drives, coal, grain, stone and ore handling machinery, factory and shop trucks, turntables, tracks, overhead shop track conveyors, jib cranes, incline elevators, etc., etc.

The plant is situated at the western end of the city and occupies a site of approximately eight acres. As may be seen from the plan on page 18, the various buildings are compactly arranged and there is ample space for further extension when required. Spur tracks

from the Canadian Pacific Railway are conveniently laid out to serve the yard and the raw and finished material sheds.

Pelham Avenue divides the site into two parts, the metal working shops being to the north, while the wood pulley factory and power house are to the south of this street.

Making Split Wood Pulleys.

The wood pulley shop is a 3-storey brick building, measuring 248 ft. by 52 ft. On the ground floor the material for the finished pulley is gotten out, the stock for arms, hubs and bushing going through the various stages on one side of the shop, while a continuous stream of segments for rims is turned out on the other side. This material then ascends by elevators to the second floor, a view of which is shown on page 19. Here various processes, such as glueing and nailing up rims, anchoring arms into rims, boring, turning and balancing, take place. The top floor forms the paint shop and stock room.

It will perhaps be interesting to follow the various operations in a little more detail, and trace the course of the lumber from the lumber pile to the stock room. A stock of over 1,000,000 feet of lumber is kept on hand, hard maple being used for the pulley arms and soft maple for the rims—only the best quality being used in both cases. From the stock yard the lumber is, of

course, taken first to the dry kilns, three in number. These are situated behind the power house and are heated on the Sturtevant system, with air heated by exhaust steam. They are also fitted with coils for heating by live steam if necessary. The trucks emerge from the kilns by doors opposite those by which they entered and are then carried by a transfer track to the planing mill, which lies parallel to the kilns, the power house intervening. Rim stock (soft maple) and arm stock (hard maple) are kept separate, and in describing the various processes it will be more convenient to consider each separately.

Rim stock on entering the planing mill is first rough sized to thickness on a planer which is in line with the track by which the stock is brought from the kilns. It is next taken to a cross cut swing saw and cut roughly to lengths suitable for segments to form the rim of the particular size of pulley being made; the number of segments, of course, varies with the diameter of the pulley. Before passing to the band saws the stock is tongued and grooved in a matcher. Besides cutting the tongue and groove, this machine also glues the joint. Several lengths of stock are next jointed together and placed in a clamp.

In this way the waste of lumber when cutting out the segments is reduced to a minimum. Fig. 3 clearly shows this;



FIG. 1. BIRD'S EYE VIEW OF DODGE MFG. CO. PLANT.

it will be seen that six segments are cut from four pieces of stock, though each individual board is only large enough for one segment if sawn separately. The cutting out of the segments is done on a hand saw, the table of which is fitted with a simple radial attachment. From the time the lumber leaves the planer at the entrance to the shop it is carried along from one machine to another on special trucks, one of which is seen in Fig. 5.

From the band saw the segments go to a planer and are there planed to a uniform thickness of $1\frac{1}{8}$ inch. They then pass to a circular saw, the table of which is fitted with a series of stops, by means of which each segment is cut off to an exact fractional part of a circle. The next step is to cut the dovetails seen in Fig. 8 at each end of every segment, this being done on a special dovetail saw.

The segments now go up to the second floor. They are here laid out in a circle and wooden keys are driven into the dovetails, at the end of which operation each course appears as in Fig. 8. These rings, or courses, are then taken to the glue room, which occupies one end of the floor and is equipped with a large coil box, powerful screw clamps, etc. A number of courses are here glued together to form the required width of pulley. In the case of a pulley requiring eight courses, four are left cold. The hot courses are glued on both sides and a cold and a hot ring placed on top of each other alternately. In this way the glue is kept thoroughly fluid for some time after the pulley has been placed in the press.

These presses have screws $2\frac{1}{2}$ inches in diameter, the thrust being taken by

a maple beam 12 inches square. This will give some idea of the great force with which the courses are pressed together. Each ring is pressed into absolutely perfect contact with its neighbor, so that an extremely strong joint is formed. In fact, we believe that experiments have proved that the joint is actually stronger than the solid wood.

After remaining in the glue press until thoroughly set, the pulley rims are taken to the chuck lathe to be "guttled," i.e., turned out inside to the required dia-

This prevents any possibility of the two halves of the pulley being assembled the wrong way round on the shaft.

The rim is now marked from a template and has the notches for the arms cut out on a band saw. This method of attaching the arms is an exclusive Dodge feature and is clearly seen at (D), Fig. 7. A wedge (B) secures the dovetail joint and the arms are further held in place by anchor bolts (C), which prevent all motion at the dovetailed joint (D). These bolts are secured in the rim by concealed malleable nuts (E). It will be seen that rim is not pierced at any point; consequently the entire rim face is left smooth and intact, presenting a continuous belt surface with no projecting ends of arms to act as belt destroyers.

How the Arms are Made.

Returning now to the ground floor we may rapidly follow the course of the hard maple (arm stock). The machines operating on this stock are all arranged along the south side of the planing mill, while those dealing with rim stock are on the north side.

The arm stock on coming from the dry kiln is cut to rough length by a swing saw and is next rip-sawed to width. The stock is then taken in convenient trucks to a jointer, and jointed on one edge and face, afterwards being planed to a uniform thickness. A bevel saw next cuts it to length and the arms are then ready to have the hub blocks inserted. For this purpose they pass to a gainer and are gained out at the centre. The hub blocks are then driven in and the arms are returned to the gainer and cleaned off flush on the edges, for which purpose the machine is fitted with a special head.

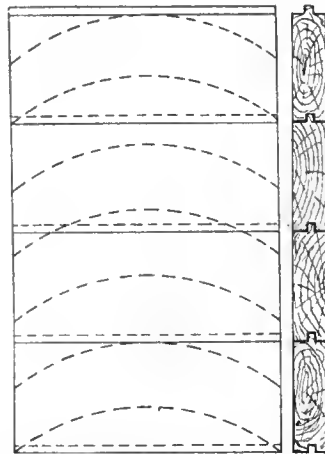

FIG. 3. SHOWING METHOD OF ECONOMIZING LUMBER WHEN SAWING SEGMENTS FOR WOOD PULLEY RIMS.

meter. They are then ready to be split horizontally and dovetailed for the arms. The splitting is done on a band saw, but the cut is not a straight line. For when the saw has entered a short distance the operator gives the work a slight twist and afterwards allows the saw to run out straight; so that the cut is somewhat in the shape of a very flat ogee.

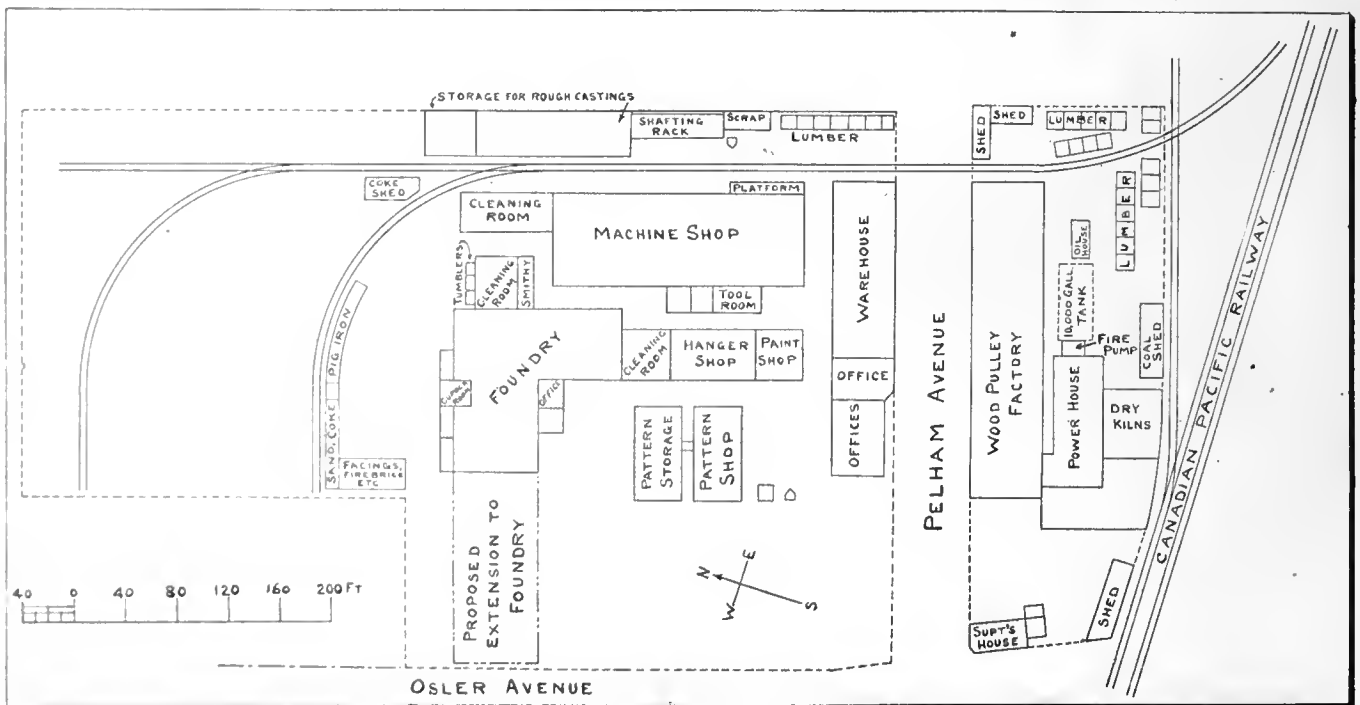

FIG. 2. PLAN OF DODGE MANUFACTURING CO. WORKS.

The arm stock now passes up to the second floor, where it is dovetailed for the rim fit by a special horizontal circular saw. The bolt holes for the compression and anchor bolts are next drilled, after which the arms are ready to be fitted to the rim.

The two halves of the pulley are now bolted together, with slips of wood inserted at the joint of the hub; and the hole for the shaft or bushing is bored

parts, the west end being occupied by the paint shop, while the rest of the flat forms the wood pulley stock room. On coming into the paint room the pulleys are first given a coat of boiled oil all over. The periphery is then filled with a special silax filler, which "case-hardens" the face of the pulley. The arms, hubs and inside of rims are covered with a special mixture of blue-black lead and oil pulley paint. In addition

with all intermediate diameters and widths. The stock on hand at any one time averages 20,000 pulleys, in addition to those carried at the firm's city office in Toronto and at their large warehouse in Montreal. The average output is 300 pulleys per day, but this quantity is capable of being increased at any time.

In addition to pulleys the stock room carries enormous quantities of hard wood bushings. This system of inter-



FIG. 5. SEGMENTS READY FOR FORMING INTO RINGS. ILLUSTRATION SHOWS CONVENIENT TRUCK BY WHICH THEY ARE MOVED ABOUT THE SHOP.

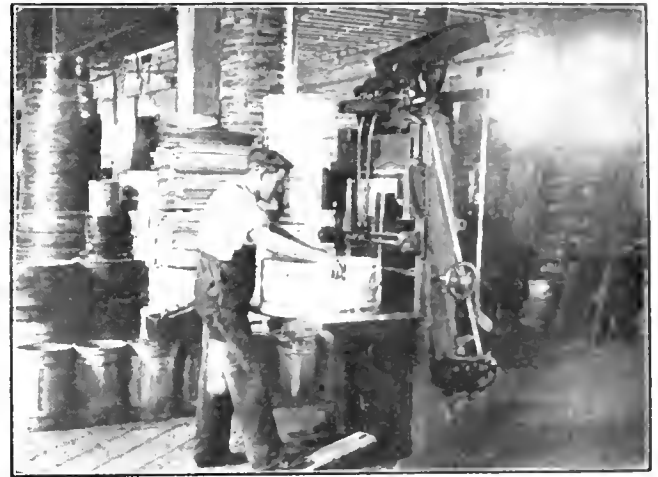

FIG. 6. WOOD PULLEYS BEING NAILED ON NAILING MACHINE.

out in a chuck lathe. The insertion of the wood slips prior to boring is for the purpose of making provision for compression when the pulley is mounted on the shaft. All standard pulleys have either 1 1/16 inch, 2 7/16 inch, 3 inch or 3 1/2 inch—the outside diameter of the bushings being made to correspond. From the chuck lathe the pulley goes to the nailing machine seen in Fig. 6, where the segments are very thoroughly nailed. This machine is by the Morgan Machine Co., Rochester, N.Y., and will easily drive 8-inch nails.

Up to this stage the pulley has not yet attained its full width of face. So from the nailing machine it goes back to the glue room and has two outside courses glued on. These assist in preventing any side movement of the arms and give a nice finish. The next step is the turning of the pulley on the sides and face of rim. This is done in special lathes, which automatically size the pulley, both as to diameter and width. After being turned the pulleys are accurately balanced on a special balancing machine of the company's own design. They then pass again to the nailing machine to have the outside courses nailed. This does not disturb the balance in the least as only two nails are driven into each segment, and care is taken to locate them symmetrically around the rim.

The final operation is now performed, viz.:—painting and varnishing. The top floor of the factory is divided into two

to this the entire pulley receives a liberal coating of waterproof varnish.

The Stock Room.

When dry they are removed to the stock room, alongside the paint shop. Here the smaller pulleys have their rims wrapped in stout paper, while larger sizes are wrapped with wood veneer. The Dodge Co. carry in stock all sizes of split wood pulleys from 4 inches diameter by 12 inches face up to 48 inches diameter by 12 inches face.

changeable bushings, originated by the Dodge Co., was the means of completely revolutionizing the pulley trade; since their use enables any pulley to be fitted to any size of shaft, within certain limits. The bushings are all of best selected hard maple and are turned from square stock in the planing mill. After being sawn to length, the stock is turned on a lathe fitted with a sizing stop. The turned bushing is next split on a machine designed and built by the Dodge Company. It consists of two small cir-

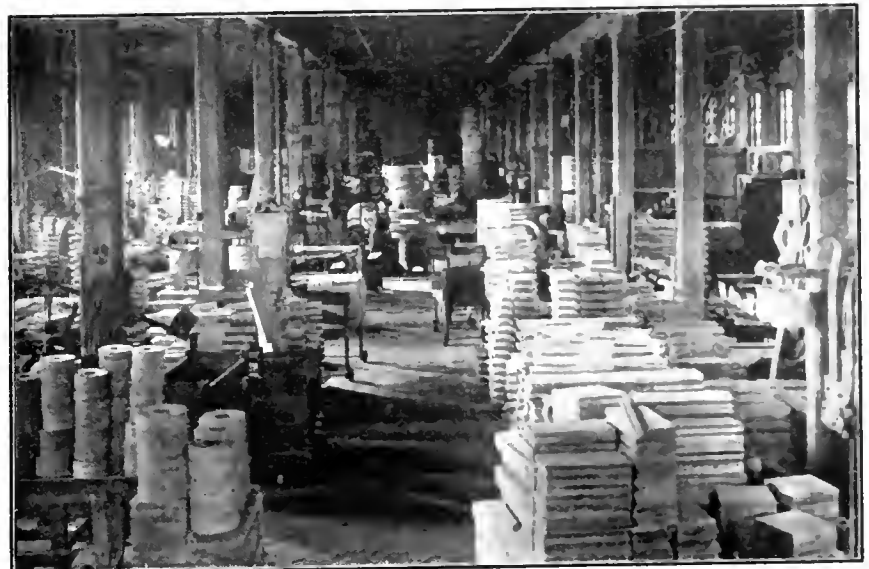

FIG. 4. VIEW ON MIDDLE FLOOR OF WOOD PULLEY FACTORY.

ular saws running horizontally. The table is pushed by hand between the saws and the bushing is thus accurately and rapidly cut in halves.

The ground and second floors are equipped with an efficient exhaust blower system with suction pipes leading to hoods covering the cutters of every machine where possible. Floor sweep openings are provided for machines such as chuck lathes, which cannot be equipped with hoods. In this way all shavings, dust, etc., are carried off to the power house and burned under the boilers. The wood pulley factory is heated by indirect radiation, and artificial lighting is provided by incandescent drop lights. The various machines are operated from line shafting driven by motors, the current being partly generated in the works power plant and partly purchased from outside sources, as will be explained later.

From the above description it will be seen that the Dodge split wood pulleys are constructed by the most modern methods and are of the best material. All pulleys over 36 inches diameter are made with two stub arms at right angles to the main arms. These are secured in the hub and rim by a tenon and mortise, but, as in the case of the main arms, do not pierce the rim. Thus the continuous belt surface of the periphery is not broken. The arms, as may be seen in Fig. 7, are cut away along their middle line as much as is consistent with an ample factor of safety, in order to reduce windage to a minimum. The Dodge Company have made thousands of special wood pulleys in addition to their standard lines. The smallest ever made by them was 2 inches in diameter and the largest

The Main Works.

The offices, warehouse and main shops are situated on the north side of Pelham Avenue and, as may be seen from the plan on page 26, are very compactly arranged. The lay-out shows careful thought and is designed to allow of continuous movement of castings in a direct line from foundry to ware-

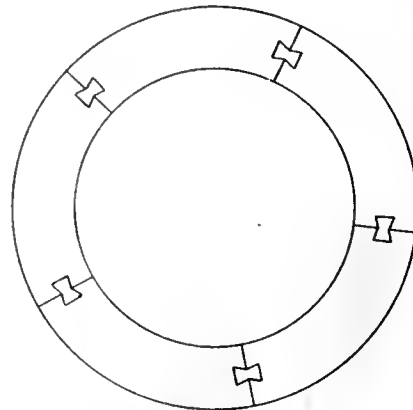

FIG. 8. JOINTING OF WOOD PULLEY SEGMENTS.

house. The latter, it will be noticed, is situated at the south end of the site and the foundry at about the centre. North of the foundry storage bins is a spacious yard which allows ample space for future extensions. It is at present used for lumber storage, etc.

The Pattern Shop.

Taking the various shops in their logical sequence, we first come to the pattern shop, the location of which is seen on the plan on page 26. This is a brick building of two storeys and an attic, and measures 75 ft. by 32 ft. The ground floor is chiefly used as a foundry carpenters' shop, and for roughing out material for the patternmakers upstairs. It also accommodates the heavier machinery, such as rip saws, cut-off saws, planers, jointers, etc. Here also are located the lavatories and toilet rooms for the patternmakers.

The second floor is the pattern shop proper, and forms an exceptionally well lighted, airy shop. Exhaust blowers, situated on the ground floor, carry off all shavings and dust from every machine and convey same to a shavings vault outside the shop. There is accommodation for twelve patternmakers, each of whom has a bench at a window, equipped with an Emmert universal vise. The foreman has a well lighted office in one corner, from which he has a clear view of the whole shop. There is a full equipment of hand saws, turning lathes, sanders, etc., including a patternmakers' double disc sander designed and built by the Dodge Company. This is equipped with a tilting table and has proved a great labor saver.

The method of making fillets in this shop is an interesting one. Instead of using leather the Dodge Company make their fillets from a special mixture, of which the chief ingredient is beeswax. The mixture is heated and forced through a small cylinder under great pressure. As it emerges it is wound off upon reels. This fillet wax is made in two sizes, 1/8-inch and 3-16-inch in diameter. To use it the pattern is given a touch of shellac to make the fillet stick; a length of wax is then rolled off the reel, dipped into hot water to soften it, and pressed into place by a brass slicking tool rounded to the correct radius. In this way a cheap and durable fillet is formed, the wax rapidly becoming as hard as dry putty.

The attic of the pattern shop is used for storage of those patterns that are so frequently used that it is convenient to have them near at hand. But the greater bulk of the patterns are kept in a special store, which is a building of exactly the same size and style as the pattern shop and is connected thereto by a bridge with intervening fire doors.

Pattern Storage System.

The total number of patterns probably amounts to between 35,000 and 40,-

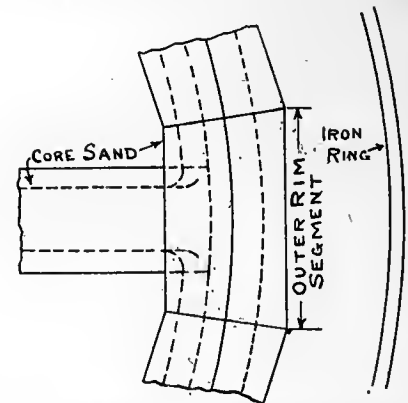
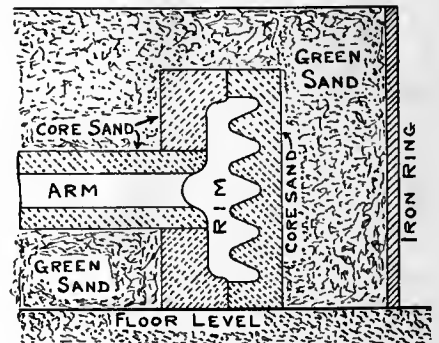

FIG. 9. METHOD OF MOULDING LARGE PULLEYS.

000; and yet any one can be quickly found when wanted. The pattern store, of course, has the usual shelves and is divided up into streets and aisles, each bearing a distinctive letter. Each aisle is divided into two sections, numbered 1 and 2.

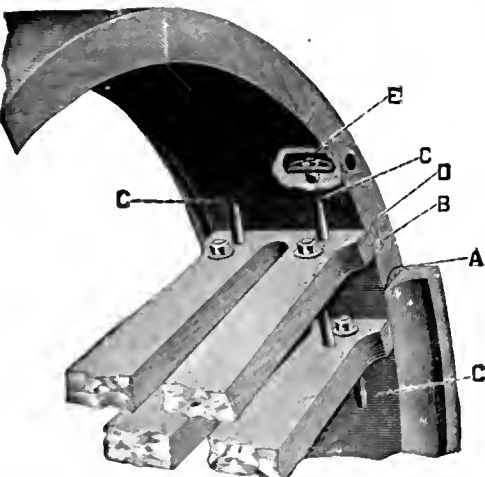

FIG. 7. DETAIL OF CONSTRUCTION OF "DODGE" WOOD PULLEY.

20 feet. To turn the latter a gap had to be cut in the shop floor and a special rigging fixed up.

About 100 men are employed in the wood pulley department, which is approximately 33 per cent. of the total pay roll.

The patterns are classified into groups such as hangers, take-ups, belt-tighteners, pillow blocks, etc. Each group is given a symbol letter taken from near the beginning of the alphabet, and sub-groups have an additional letter from nearer the end. For instance, all shelves for rope drives are in group A, and letters such as O, P, R, indicate the particular size of rope for which sheave is intended. Each individual diameter and width of face is, of course, given a separate number. Thus A.O.600 will indicate, let us say, a sheave for 1-inch rope, 40 inches in diameter and having 12 grooves.

When an order is received calling for a new pattern the engineering department allot the latter a number in its proper group, at the same time making out a card for their card index. A duplicate of this card index is kept by the foreman patternmaker, who, on completion of the new pattern, enters on his card the number of the floor, aisle, section and shelf where the pattern is to be found in the pattern store. This record is also added on the engineering department's card as a precaution against the accidental destruction or loss of the foreman's card.

The ground floor of the pattern store carries the heavy wood patterns and the metal patterns used on the moulding machines, the lighter patterns being stored on the second floor. The attic is given over to patterns that are seldom used.

The Foundry.

The foundry building is in the shape of an inverted letter L, the long leg being used for heavy work, and the short leg for machine moulding and light work generally, such as hangers. The heavy foundry lies approximately east and west and measures 124 ft. by 66 ft. It is intended in the near future to extend this building westward to the boundary of the company's property on Osler Avenue.

The heavy foundry is divided into two side bays of 16 ft. each and a centre bay of 30 ft. The latter is served by a 10-ton, 3-motor, overhead traveler built by the Morgan Engineering Co., Alliance, Ohio. The centre bay is of considerable height, the crane rails being about 28 ft. above floor level. This enables large pulleys, flywheels, etc., to be conveniently handled.

The north 16-ft. bay is occupied by the core ovens, cupola room and the bench moulders. The core ovens, three in number, are in the north-west corner, the core makers being immediately opposite in the south bay. The cupola room measures 20 ft. by 17 ft. and contains two Colliau cupolas. The larger is a 64-in. with 9-in. lining, and the smaller a 44-in. lined up to 34 in. The

latter cupola is seldom used. Blast at 12-oz. pressure is delivered by a Buffalo Forge Co.'s 48-in. "Noiseless" blower, belt driven by a 35-h.p. induction motor. Pig, coke and limestone are brought by an electrically operated elevator to the charging platform and there weighed on platform scales. The cinder mill is conveniently situated near the cupolas on the ground floor. Sand, coke, etc., are discharged from the railroad cars direct into storage bins alongside the track, thus reducing handling to a minimum. These bins are shown on the plan, a short distance to the north of the foundry.

The Dodge Co.'s method of moulding large rope sheaves, large belt pulleys, etc., is of considerable interest. Instead of sweeping up the rim in loam or green

outside rim segments are placed. The hub is then completed, all joints are made good with clay and a wide cast iron ring, somewhat larger in diameter than the mould, is dropped over the latter and green sand rammed around the dry sand cores, as clearly shown in the cut. This method has proved highly satisfactory, the loss of a casting being an extremely rare occurrence.

Castings up to 11 tons in weight are frequently made in this foundry and the total output averages 85 tons per week. Belt pulleys from 26 in. to 48 in. in diameter are made on stripping plate pulley moulding machines and the output of the light foundry is nearly all machine work. It consists chiefly of standard parts, such as hangers. Conveyor stands, small hangers and similar

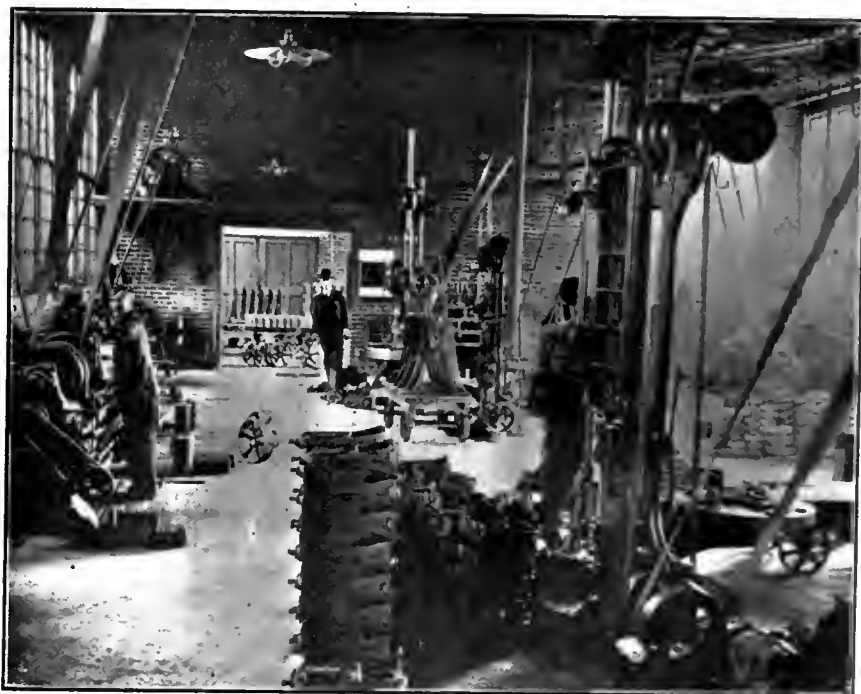

FIG. 10. A SECTION OF THE HANGER SHOP.

sand and making the hub and arms in dry sand, as is the common practice, they always mould the outside face of the rim in dry sand and frequently the inside face also. Fig. 9 shows how this is accomplished in the case of a rope pulley, the rim and part of one arm only being shown. The rim is moulded in dry sand segments, each segment being made in a core box. Very large or wide pulleys are moulded in a pit, but those of moderate size merely have the floor levelled off and a flat core plate, to build up the hub cores upon, bedded into the floor. A circle is then marked out on the floor and the rim core segments are set to this. In the case of a six-armed wheel, six of the inner core segments are provided with an inlet for the arm core. The latter is inserted before the

castings are made on Pridmore drop plate machines, and there is a Pridmore stripping plate machine which is usually kept busy on 6-in. pulleys. A man can mould 170 of these pulleys on it per day of nine hours. All the machines are hand operated since the foundry is not yet piped for air. It is the intention in the near future, however, to instal an air compressor to supply the foundry and machine shop. A sand blasting outfit will be put in at the same time.

The foundry foreman's office is in an annex to the main building and behind it is a small room in which are placed the patterns from which castings have been ordered. Alongside the office is the men's wash room, etc., and above it is a comfortable room for use of the men during the noon hour. They can

take their dinner here if they wish; and magazines, both technical and popular, are provided for their instruction and amusement.

Cleaning Department.

A study of the plan on page 26 will show that the light and heavy foundries each have their own cleaning departments to which the castings move by a straight route. There are really two cleaning rooms for the heavy foundry, the old hanger shop at the north end of the machine shop having recently been converted into a cleaning department, and it is here that the larger castings are fettled. In this shed there are three automatic pulley grinding machines. Two of these are special machines designed and built by the Ford-Smith Machine Co., Hamilton, Ont. They have a capacity for pulleys up to 13 inches diameter by 18 inches face.

The Hanger Shop.

This is a new shop, built this year to relieve the main machine shop. As its name implies, it is chiefly, though by no means entirely, employed in machining and assembling hangers. It also looks after large couplings, take-ups, stock pulleys, etc. Standard bearings are also babbitted here. It is a well lighted shop with a concrete floor, 62 ft. by 40 ft. The principal machine tool equipment includes 24-inch Gisholt lathe, 36-inch and 45-inch vertical drill presses, 16-inch and 18-inch engine lathes, 24-inch engine lathe with taper attachment and turret head, 24-inch turret lathe, Baker keyseating machine and several small sensitive drills. These machines are all operated from one line shaft driven by a 20 H.P. motor.

From the hanger shop the work passes to the adjacent paint shop and thence to the warehouse. Part of this paint

2-inch tongued and grooved pine floor spiked. On top of this, and running at right angles to it, is a 1-inch maple floor. This makes an excellent floor—dry, warm and durable.

The shop is divided up into well-defined departments, each with its necessary equipment of machine tools. Thus work on the Dodge and Orton clutches, of which the company turn out large numbers, is done in one corner, shafting is turned in another, while general assembling and fitting is done in a third. The machine tools occupy the body of the shop and are driven from line shafts, with the exception of a new 72-in. Bertram boring mill, recently installed, which has an individual motor drive.

Naturally in a shop of this description jigs and fixtures are very extensively used. Every possible operation that can be expedited by jiggling has had a jig designed for it. This of course not only reduces the expense of manufacture, but also ensures that perfect interchangeability for which the Dodge Co. have earned an enviable reputation.

There are three shafting lathes all by the John Bertram & Sons Co. These are used for turning down from rough stock all shafting over 3 7-16 in. in diameter. Up to this size cold-rolled shafting is usually supplied. Shafts as long as 32 feet can be turned when required. They are turned from the black stock at one operation by a turning head attachment bolted to the carriage. This head is fitted with a bushing which is .0015 in. larger than the finished size of the shaft. After straightening and centering, and before the turning head is attached to the carriage, the tailstock end of the shaft is turned down for a distance of 6 or 8 inches to fit the bushing. The turning head is now introduced over this end of the shaft and bolted to the carriage. The head is fitted with three tools. Two are on the headstock side, set one slightly behind the other and on opposite sides of the shaft, and the third (a finishing tool) is on the tailstock side. In this way the shaft is reduced from the rough to the finished diameter by one passage of the head, the first tool giving a roughing cut, the second an intermediate and the third a finishing cut. A first-class finish is obtained with a fairly coarse feed—6 threads per inch.

After being turned the shafting is polished in a special polishing lathe and tested throughout its length by a ring gauge. The ends are then turned down to a special gauge, to which the couplings are also bored. In this way absolute interchangeability of couplings is assured, and should one get broken a customer has only to wire the size of shaft to the Dodge Co. and promptly receive a new coupling, upon which he

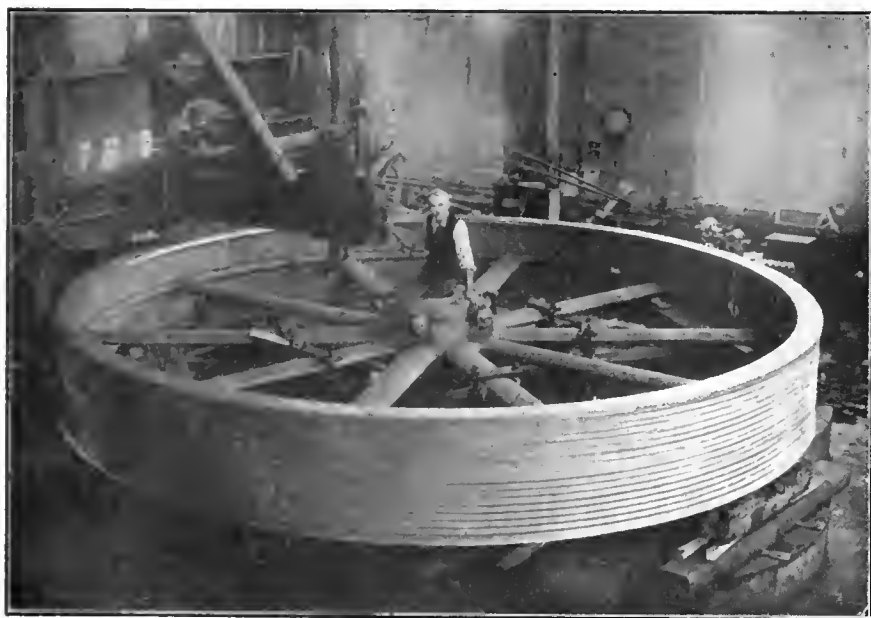

FIG. 11. A 20-FT. ROPE SHEAVE BEING BORED AND TURNED AT ONE SETTING ON A 10-20 FT. BORING MILL.

The main cleaning room, situated at the east end of the heavy foundry, is equipped with the usual grinding stands fitted with exhaust hoods. There are three tumblers 36 in. by 50 in., these being housed in a lean-to which is cut off from the cleaning room by swinging shutters. In this way dust is kept down to a very marked extent.

The cleaning room for hangers and other stock jobs is at the south end of the light foundry and adjoins the hanger machine shop. It is equipped with two tumbling barrels and ring wheel grinding machine with automatic traveling table, on which the bases of all hangers are dressed up true. This grinder was built by the Dodge Co. and turns out accurate work quickly and economically.

shop will be partitioned off for the air compressor plant which it is intended to instal.

The Machine Shop.

This is a well lighted building, 196 ft. long by 80 ft. wide. A monitor roof lights the centre bay, which is 40 ft. wide and is served by a 10-ton Morgan crane, similar to that in the foundry. The two side bays are 26 ft. wide and are excellently lighted by numerous side windows. An industrial track traverses the floor, but is not much used, as shop floor trucks are found to give a more flexible service both here and in the hanger shop. The machine shop floor is of an interesting type of construction. It is laid on six inches of tarred cinders, tamped to a level. On top of this is a

will not require to do any work beyond pressing it on the shaft and driving in the key. This interchangeability has been brought to so fine a pitch in all Dodge products, that even their friction clutch members are produced in large quantities and taken from stock promiscuously as required.

In addition to their standard lines the company do a large amount of special work. Fig. 11 shows a 20-ft. rope sheave being turned and bored on a Belts 10-20 ft. boring mill with the housings moved back, and the handling of heavy work of this description is not looked upon as anything extraordinary.

Pulleys have their keyways cut in a Baker keyseater having a stroke of 27 inches. In the case of very wide faced pulleys, which will not go on this machine, the work is done on a 60-in. x 60-in. x 24-ft. Bertram planer by means of

ly. Larger pulleys are turned on face lathes or on one of the three boring mills. There is an Ingersoll slab miller, chiefly used for keyseating shafting, two Bullard vertical turret lathes and a Bertram 72-inch full universal radial drill. These are merely mentioned to show that the equipment is of the best. There is also a full equipment of Aeme bolt cutters and a Bertram 6-spindle nut tapper.

Pulleys up to 60 inches in diameter are balanced on an interesting machine designed and built by the Dodge Co. In this a horizontal mandrel, supported on ball bearings, carries the pulley. A vertical drill attached to a table having horizontal and vertical movement stands above the mandrel and can, of course, be raised or lowered to suit various pulley diameters. When the pulley is placed on the mandrel, with a sleeve to fit the

chine shop accommodates the tool room, office and lavatories. The tool room measures 46 ft. by 19 ft. and gives employment to about half a dozen men. The equipment is of the usual type and includes a Cincinnati No. 3 universal miller and a Bath No. 2½ universal grinder, together with tool-room lathe, shaper, drill grinder, etc. The numerous jigs for standard and special work are all made here and are stored in convenient racks. The foreman toolmaker is also responsible for the issuing of tools, gauges, etc., to the machine shop, the check system being used.

There is a spacious and well-lighted office next to the tool room for the foreman and the order clerks, and alongside this is the men's washroom. Above the latter there is a dining-room similar to that in the foundry and previously mentioned.

Waste cans are provided throughout the shops for oily waste and other rubbish and the men are encouraged to keep their machines and the shop generally in a clean and orderly state. A general suggestion box is also located in every shop, for the purpose of receiving any suggestions which employees may feel like addressing to the superintendent. This box is opened weekly and cash payment is made for any suggestion of value to the company, who do everything to encourage men to qualify themselves for advancement.

Outside the machine shop, at the north-east corner, is a shipping platform from which heavy or bulky material is loaded into the ears. Below this platform is a large power ear haul, driven by a friction clutch from a line shaft inside the machine shop. This enables ten loaded ears to be pulled in either direction on any of the company's various sidings. These, by the way, aggregate a total of 1,500 ft., serving the coal storage bins and foundry yard, as well as the various lumber piling yards, making one of the most complete industrial siding services in the province.

The Warehouse.

This is a new brick building of three floors, erected in the summer of 1912. It measures 175 ft. by 47 ft. and runs at right angles to the hanger and machine shops, from which it is separated by about 20 feet. The building is in charge of a warehouseman who receives all in-coming goods and keeps up the stock, but has nothing to do with outgoing goods, which are looked after by the shipping clerk. Offices for both departments are on the ground floor which forms the shipping and receiving room and also accommodates the petty stores. The ground floor is of concrete, and the second floor consists of 8-in. by 2-in.

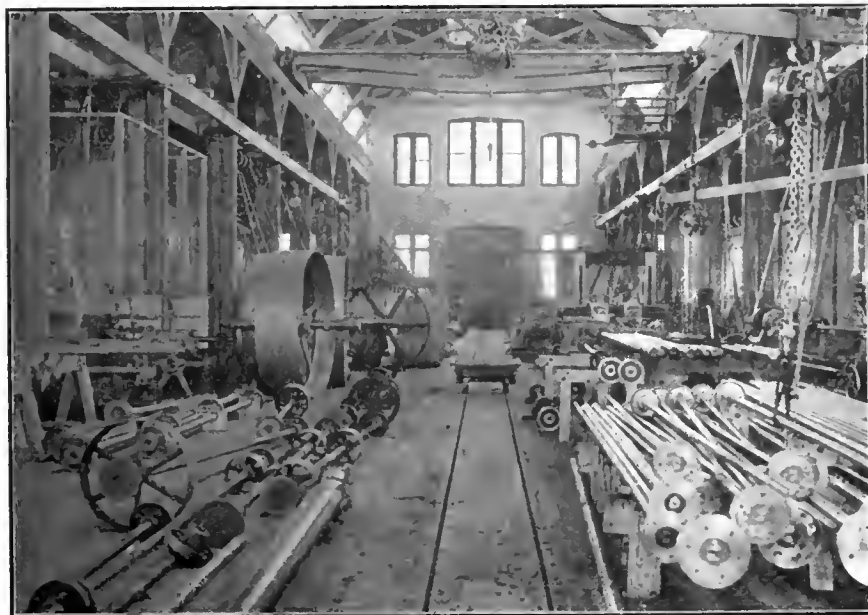

FIG. 12. INTERIOR OF MACHINE SHOP LOOKING NORTH.

a special attachment. The latter consists of a large angle knee fitted with a bushing to suit a cutter bar. The bushing fits in a slide which can be moved vertically by a screw having the same pitch as that controlling the vertical movement of the planer cross rail. The clapper box is removed from the planer head and its hinge pin used to carry one end of the cutter bar, the other end of which passes through the pulley bore and into the bushing in the angle bracket. The latter is of course bolted to the planer table, as is also the pulley. The tool is fed vertically by means of the screws mentioned above.

The machine tool equipment is all of a thoroughly modern description, but does not call for any very extended notice. There are three pulley lathes of 20, 24 and 36 inches capacity respective-

ly, it oscillates and finally comes to rest with the heavy side at the bottom. The correct spot to drill the rim for a balance weight is thus brought automatically directly below the drill.

This shop turns out a very large quantity of machinery for grain elevating and conveying and there is practically always work of this class on hand. Among other large elevators equipped in whole or in part by the Dodge Co. may be mentioned C.P.R. elevator, Port McNicoll; new annex of G.T.P. elevator, Fort William; Goderich Transit and Elevator Co.; Maple Leaf Milling Co., Port Colborne; G.T.R. elevators at Montreal and Tiffin; Harbor Commissioners' No. 1 elevator and a large part of their new elevator at Montreal.

An annex on the west side of the ma-

lumber flooring laid on edge and supported by 24-in. steel beams. On top of the 8 x 2 lumber is laid a tongued and grooved hardwood floor at right angles. It is designed for a load of 800 lbs. per square foot. The top floor is of similar construction, good for 600 lbs. It is formed of 6-in. by 2-in. lumber resting on 18-in. beams.

On arriving from the machine shop or hanger shop material is distributed to the shipping department or to the different floors of the warehouse. If it is for stock it will go to the second or third floor. On the second floor are stored hangers, bearings, couplings, pillow blocks, etc. The Dodge Co. make over two hundred different patterns of hangers and keep in stock about one hundred of each standard size of each type of hanger. Three styles of bearings are made, viz., ring-oiling, standard and capillary oiling, any one of which can be fitted to any standard hanger.

On the top flat of the warehouse are stored sprocket chain and attachments, take-ups, spiral conveyors and their fittings, steel split pulleys and their bushings, and also a large stock of solid and split cast iron pulleys.

Each floor is fitted with substantial shelves and racks for the convenient classification of the various stock parts. A Turnbull freight elevator, electrically operated, runs the full height of the building.

The Power House.

As previously mentioned the company purchase about 100 h.p. from the Toronto Electric Light Co., but generate 450 h.p. in their own power house. This is located behind the wood pulley factory which it was originally designed to drive.

The boiler house contains three return tubular boilers rated at 150 h.p. each. These were built by the John Inglis Co., Toronto, and are operated at 120 lbs. pressure. They are hand fired, the fuel used being a mixture of soft and semi-anthracite screenings. Natural draft is provided by a steel stack 48 inches diameter by 130 feet high. The boiler pressure is governed by an automatic damper installed by the McDonough Automatic Regulator Co., Windsor, Ont. One of the boilers consumes all the sawdust and shavings brought over by the exhaust blowers from the planing mill, etc.

The engine room contains a 100 h.p. tandem compound horizontal engine which has given excellent service for a good many years. It was built by the Osborne-Killey Co., of Hamilton, Ont. This engine drives the wood pulley shop by means of a Dodge rope drive. In addition to this there is a McEwen en-

gine by the Waterous Engine Works Co., Brantford, Ont. This is direct connected to a Canadian General Electric D.C. generator of 100 K.W. capacity. This supplies current at 250 volts for the overhead cranes and for the lighting circuits in certain of the buildings. At one end of the engine room is a large fan for heating the dry kilns and the wood pulley shops by the Sturtevant system. All other shops are heated on the Webster system of direct radiation, the exhaust steam pipes and returns being taken across from the engine room to the main works through an underground tunnel across Pelham Avenue.

Fire Protection, Artificial Lighting, etc.

Every building on the plant is protected by a Grinnell automatic sprinkler system piped to the city water service. In addition to this there is an Under-

partment 16 c.p. drop lights are used. The foundry is lighted by enclosed arc lamps, supplemented by drop lights in the core making and bench moulding departments. The hanger shop, machine shop and warehouse are illuminated by 100-watt tungsten lamps. In the machine shop these are arranged in clusters under enamelled reflectors with fine effect.

The Executive Offices.

To run this extensive business the Dodge Co. maintain a highly systematized staff, who occupy comfortable quarters in a handsome two-storey office building of red pressed brick. The staff is divided into a number of departments, each under the supervision of an expert. These divisions include the accounting department, equipped with

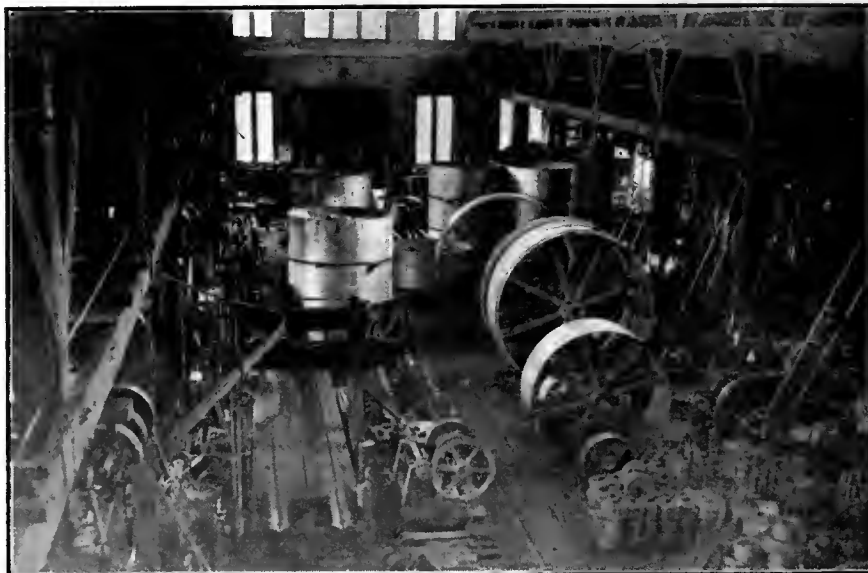

FIG. 13. INTERIOR OF MACHINE SHOP LOOKING SOUTH.

writers' fire pump housed in a brick building alongside the boiler room of the power plant. This is a 18-10-12 duplex pump built by the Canada Foundry Co., and has a capacity of 1,000 gallons per minute. One-inch fire nozzles attached to 50 ft. of 2½-in. hose are located in suitable positions in each shop. The fire pump draws from a reinforced concrete tank of 100,000 gallons capacity. This tank is situated underground alongside the pump house and holds city water held in reserve for fire fighting purposes only. The ordinary water service throughout the plant is derived from the city mains; but as precaution against temporary failure of this supply there is a large tank on the third floor of the wood pulley shop, which holds half a day's supply.

Artificial lighting is carried out in the manner best suited to the individual needs of the different shops. Thus in the pattern shop and wood pulley de-

modern labor-saving devices such as listing and adding machines; the order department, which is in charge of a man of many years' experience in the company's works; the purchasing department; the sales department, in charge of an expert who has full supervision over travelling salesmen, agencies and sales generally; the charging and billing department, where again the most modern methods are in vogue; and the publicity department, which is fully manned and equipped for the regular sending out of the company's continuous flow of advertising literature, which is sent out monthly from coast to coast. This includes the periodical issue of a very complete catalogue which describes and illustrates the full line of Dodge products.

On the second floor of the office building is the engineering department under the charge of a chief engineer of many years' experience, who superintends a

large staff of draftsmen. Here are laid out and designed the various large and complete equipments of machinery for the many grain elevators fitted out by the Dodge Co. In a fireproof vault in this department are stored all the company's drawings and records, which represent an immense outlay of money.

Next comes the very complete cost-keeping department, where the cost of everything made by the company each day is actually computed from the cost of the raw material to the "cost sold" price. There is also an estimating department which provides the sales department with "cost sold" figures on all proposals.

This, in conjunction with a modern telephone and autocal system connecting all departments, tends to make Dodge service most complete. After working hours the office telephone is connected with the superintendent's house, which is on the premises. By such means as this the company's customers are given a 24-hours-a-day service and can rely on obtaining spare parts to make good a breakdown with an absolute minimum of delay.

World-wide Agencies.

The Montreal warehouse constantly carries a stock valued at \$40,000. This enables it to replenish eastern agents' stock in addition to looking after the Montreal and local eastern markets.

The Dodge split wood pulley was introduced into Great Britain in 1886, in which year it was exhibited at the Indian and Colonial Exhibition in London. The exhibit attracted great attention and resulted in the award of a diploma to the Dodge Co. This was the beginning of a business that has now grown to very large proportions.

In addition to being strongly represented in Great Britain, the company has agents in South Africa, Australia, New Zealand and the Argentine Republic. In Canada every principal city from coast to coast has its Dodge agency carrying a full line of the firm's products.

Such a large and comprehensive business has not grown up in a day. It is the result of nearly thirty years' strenuous work on the part of the management, who have always aimed at rendering a distinct service in the direction of supplying standardized interchangeable products. This end they may now be fairly said to have attained.

PROTECTION FOR TIMBER LANDS.

THE Canadian Board of Railway Commissioners has recently prescribed regulations for the prevention of fires and for regulating the operation

of locomotives during the dry season in the province of British Columbia.

This order provides that every locomotive must be fully equipped with spark arresters of a specified size, with sheet-iron dampers, overflow pipes and division points. The company must examine, at least once a week, the nettings, dead plates, ash pans, dampers, slides and fire-protective apparatus of each locomotive, and keep a record of each inspection for the Government's special inspectors who are to make an independent monthly examination. The board of railway commissioners is given power to remove from service any locomotive found defective in fire-protective apparatus. The roads are prohibited from burning lignite coal without special permission from the board, and between April and November, the burning of ties and other refuse along the tracks is forbidden. Any fire starting or burning within 300 feet of the railway track shall be presumed to have started from the railway.

A measure is being discussed by those interested in the protection of Maine timberlands from fire. It will probably be introduced in the legislature of that State during the coming winter. If passed, it will give the State Board of Railway Commissioners authority similar to that held by the Canadian Board.

ONTARIO'S GREAT WEALTH.

NORTHERN ONTARIO, its vastness, its productive capabilities, its wealth of mineral and timber, its fish and its fur, its fertile lands and the importance of the development of Ontario to Toronto, Older Ontario and the Dominion, was the subject on which Hon. W. H. Hearst, Minister of Lands, Forests and Mines in Ontario, addressed the members of the Canadian Club recently.

Ontario has been much talked about but no speaker of recent years warmed up to his subject with more vigor and effect than did the Hon. Mr. Hearst. The vastness of New Ontario and the immensity of its wealth was presented as never before.

Millions of Acres.

New Ontario comprises, the speaker said, Nipissing, Algoma, Thunder Bay, Rainy River and Kenora. Millions of acres of land were awaiting the settler in the rich clay belt. The diversified character of its products was sufficiently large to take in everything grown in Older Ontario, even to its finest fruits. Ontario's millions of acres under cultivation yielded her \$13,000,000 more than the combined field crop of the two important provinces of the West. New Ontario is equivalent to sixteen times the

area of older Ontario. Blessed with easy access to the markets of the world, Ontario was destined to become the greatest Province of the greatest Dominion of the greatest Empire. It was destined to be the greatest paper making, ore and steel country in the world.

Opening Up North Land.

The Canadian Northern, the G.T.P. and the Temiskaming and Northern Ontario Railways, were opening up large tracts of the finest lands in the world to the settler. During the past year, 1,400 settlers went in upon this land, and their success was drawing others. The possibilities of the future were, Hon. Mr. Hearst said, but slightly indicated by the work of the settler to date. However, 62,444 farms were available in the 20,000,000 acres of fertile soil.

Interesting Statistics.

With statistics at his finger ends, Hon. Mr. Hearst appeared to his large audience to be a veritable encyclopedia of areas, revenues and productions. New Ontario has 3,453 miles of railway of which 1,000 is C.P.R., 761 National Transcontinental, 1,043 Canadian Northern, 253 T. & N. O., Central Algoma 336, and Algoma Eastern 60, all opening up the best land in the Dominion. In spite of all this, the province was inadequately supplied with railways.

The red and white pine on Crown lands in Ontario was estimated to have a value of \$135,000,000, and that on licensed lands \$10,500,000, while the value of pulp wood fit to cut was \$225,000,000, or a total from timber alone of \$370,500,000.

Output of Mines.

The total output from the mines of New Ontario for the nine months ended Oct. 31, was close upon \$25,000,000. Of this \$1,117,335 was gold. In 1911, the output of nickel matte was \$3,664,474; refined nickel, \$10,229,623; copper matte, \$1,281,118; refined copper, \$2,219,264; pig iron, \$7,716,314; steel, \$9,505,013.

Water Powers.

The water powers of Northern Ontario was another element in its wealth. The capacity of the powers already are known to be over 2,000,000. The great growth of its population, especially in the Temiskaming district, where there are now 75,000 people, compared with 5,500 a few years ago, he regarded as one of the best tests of the great possibilities of Ontario.

No other province in the Dominion held out to the settler so much in the way of inducement as Ontario, he said, and no Province in the Dominion was capable of so much. Five million dollars was being expended by the Government in roads, etc., in the new districts.

CANADIAN IRON ORE OUTPUT.

THOUGH according to an official report recently issued, Canadian blast furnaces produced 15 per cent. more iron and 8 per cent. more steel in 1911 than in 1910, the output of ore by the mines of the Dominion has decreased. In fact only about 6 per cent. of the iron ore used in Canadian blast furnaces was of domestic origin and the rest imported.

The pig iron output for 1911 was 917,535 short tons, valued at \$12,307,125, compared with 800,797 short tons, valued at \$11,245,622 in 1910. The increase is 14.6 per cent. Steel ingots increased by 7 per cent., the figures being 882,396 tons and 822,284 tons.

Iron ore shipments were 210,344 tons, valued at \$522,319, compared with 259,418 tons, valued at \$574,362.

The report states that the rate of production has shown practically no increase in the last twelve years. In the same period the output of pig iron has increased about tenfold.



MONTREAL HARBOR REVENUE.

THE revenue returns received at the Harbor Commissioners' office give a total revenue for the navigation season of \$461,396.43 as compared with \$430,623.24 for the navigation season of 1911, an increase of \$30,773.19. This total has been made up of the following increases: Wharfage inwards, \$6,000; wharfage outwards, \$5,500, and from local traffic, \$19,273.19. There has been a decrease of 26 in the number of sea-going vessels entering the port during the past season compared with the arrivals during 1911. The number for the past season was 736, as against 762 for the navigation season of 1911, but there has been an increase in tonnage, the figures being 2,403,924 tons for 1912, as compared with 2,338,252 tons for 1911, an increase of 65,672 tons.



CANADIAN NORTHERN RAILWAY.

THE report of the Canadian Northern Railway Co. for the past year, which was submitted at the annual meeting of the company, is a very interesting and satisfactory document for the shareholders in the concern, for the year just closed shows a very considerable development of the work of the company, as well as a remarkable advance in construction work. No fewer than 586 miles of new construction work was added to the already extensive system, and the average mileage worked was 3,883 miles. Generally speaking, the

freight carried showed a substantial increase, while the commercial coal carried increased from 370,160 tons to 804,803 tons, which shows the very rapid increase in Western Canadian coal mining.

One of the most satisfactory features of the report is that which relates to the carriage of building material, for as buildings are only erected in Canada when they are required, the increase in the carriage of building materials by 48 per cent. is a most encouraging sign for the future prosperity of the Canadian Northern Railway, along whose line settlements are springing up with gratifying rapidity. A very good report of the progress of the general development of the company is to be found in the report, and is confirmed by the speech of the chairman at the annual meeting. The linking up of the lines of the company in the northern system of the eastern provinces with the Western Canadian lines of the company is progressing most satisfactorily. The outlook is equally promising, for the crop movement indicates a yield greater than in any previous year, and this, coupled with the fact that the market is satisfactory, is surely indicative of a substantial increase of revenue. It is true that operating expenses are on the up grade, but despite this fact, the latest returns since the close of the company's year indicate a still further expansion in the net earnings.



PROVINCE OF ONTARIO MINERAL OUTPUT.

THE annual report from the Bureau of Mines for 1911, recently issued, shows the total mineral production for Ontario to amount to \$41,976,797, an increase of 6.7 per cent. over the previous year, while during the six years ending 1911, the mineral output of the Province was increased by 87 per cent.

Silver and pig iron accounted for most of the increase, as nickel, copper, iron ore and gold showed a slight falling off. The reduction in the nickel output was \$341,861, while the others decreased in a much lesser degree.

Non-metallic products, particularly natural gas, showed a large increase, while there was a decrease in petroleum, lime, mica, calcium carbide and corundum. All building products, with the exception of lime, were produced in greater quantity and larger value.

An increasing proportion of Ontario ores are being refined in the Province, and last year 60 per cent. of the silver production was refined at home, while the balance was principally low-grade ore.

LACHINE CANAL STATISTICS.

THE Lachine Canal, which opened for 1912 on April 29 and closed on December 5, had a busy season. The records show an enormous increase in the quantity of wheat passing through it, while, in nearly every other class of freight, there was a gain.

The grain and produce carried during the year were as follows:

	1912	1911
Wheat (bush.) ..	24,345,435	18,220,411
Indian corn (bu.)	289,914	4,600,628
Oats (bush.)	9,671,815	8,163,371
Barley (bush.) ...	881,399	622,040
Rye (bush.)	25,500
Flaxseed (bush.)	758,963	207,699
Flour (tons)	456,059	*1,003,039
Eggs (cases)	17,774	14,032
Butter (pkgs.) ...	5,466	6,712
Cheese (boxes) ...	250,340	242,859
Apple (brls.)	55,169	41,293

*Sacks.

One hundred and seventy-two Canadian and 44 American steam vessels passed through the canal, with 771 barges, canal boats and schooners. There were 9,560 separate trips with a combined tonnage of 4,119,364; 6,125 permits were issued to boats compared with 5,738 last year while the passengers carried numbered 89,557.

Two hundred and three yachts and 223 tugs had canal permits; 432,478 tons of coal passed through, while 439,517 tons were landed at points on the canal banks.

There were 960 inward trips of St. Lawrence River ships to discharge cargo in No. 1 basin, or at Cote St. Paul, while 17,357 cords of pulpwood were carried to Canadian ports and 64,403 cords to United States harbors. Of pulp, 28,302 cords went to American ports, and 1,040 cords to Canadian ones.



C. P. R. GRAIN FIGURES AT FORT WILLIAM.

THAT the Canadian Pacific Railway has handled more car loads of grain in 1912 at Fort William, than ever before, is clearly demonstrated by the following official data received at the C. P. R. headquarters. The figures are also evidence that the company is doing its utmost to prevent congestion at the head of the lakes, and has so far been successful. The returns for the month of November show that 54,314 cars were handled, being a daily average of 1,810. During the corresponding month in 1911, 41,171 cars were handled, or a daily average of 1,405. Unloaded at the elevators were 16,560 cars of grain or an average of 552 daily, as against 12,409 for the same period last year, equal to a daily average of 414.

Hamilton Bridge Works Co. New Plant, East Hamilton, Ont.

Staff Article

Canada's unprecedented development during the past few years has kept all branches of the iron and steel industries working at their maximum capacity, in an earnest endeavor to overtake their orders. In common with other manufacturers, bridge builders have had a busy time and have found difficulty in keeping pace with the requirements of the railways and of the highways authorities. This article describes the first unit of a new plant recently erected by one of the oldest bridge building firms in Canada, with a view to coping with an ever increasing flow of business.

AS builders of railway bridges, railway turntables, highway bridges and structural steel work generally, few firms in Canada are better known than the Hamilton Bridge Works Co., Ltd., who have been established at Hamilton, Ont., for upwards of forty years. The company have steadily advanced step by step with the development of the country, and the products of their shops may be found in every province from the Atlantic to the Pacific.

Owing to the enormous demand of late years for all kinds of structural steel work they have for some time been hard put to it to keep ahead of their orders. About five years ago the works were entirely rebuilt and remodelled, with the result that the yearly output was trebled. But even this proved merely a temporary remedy, and it was recently found imperative to still further increase their manufacturing facilities

in view of the large amount of business offering.

The main works are situated in the north-western portion of the city and cover an area of about 8 acres, every square foot of which is fully occupied; so that any further extension was rendered impracticable. Consequently it was decided to erect a large modern plant at the east end of the city. An advantageous site of 20 acres was secured, having direct communication with the Grand Trunk, the Canadian Pacific and the Toronto, Hamilton and Buffalo Railways. The proposed new branch of the C.N.R. will also probably connect with the site.

The new plant has been specially designed for heavy truss and girder work and is occupied entirely with this work, the bolt and rivet making departments and machine shop being still located at the company's up-town plant.

Layout of New Plant.

So much of the new plant as is already built and in operation merely forms a first unit, the layout having been very carefully arranged to allow of extensions in all directions to the full capacity of the site. This first unit comprises three buildings and a stock yard, together with the necessary railway spurs. The stock yard is at the east end of the structural shop.

Of the three buildings, the first to be noticed is that containing the air compressor room, boiler room, and template and pattern shop. This is a one storey brick building, 180 ft. by 50 ft. The roof is carried by steel trusses and has a 20 ft. monitor. The compressor room and boiler room have floors of concrete, while the template shop floor is of 2 x 4 in. lumber, laid edgewise upon steel beams spaced at 12 ft. centres. On top of this is laid a 1-inch pine wearing

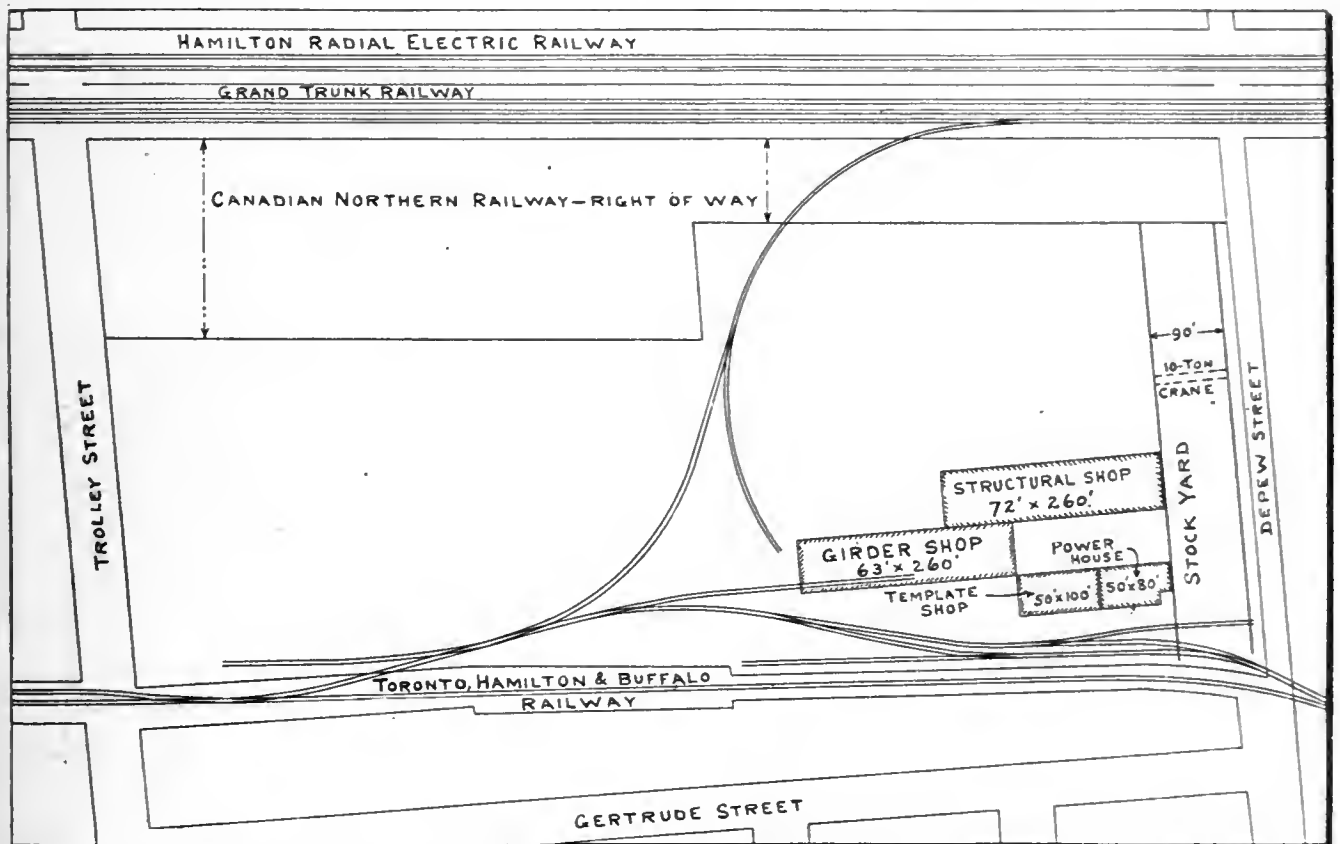

FIG. 1. LAYOUT OF NEW SITE, SHOWING THE LARGE AMOUNT OF SPACE AVAILABLE FOR FUTURE EXTENSIONS. HAMILTON BRIDGE WORKS CO., LTD.

floor. The steel joists rest on concrete piers, the whole forming a warm, dry floor. The window area is unusually large, with steel sash throughout; so that excellent natural lighting is secured.

The second building forms the structural shop. It measures 260 x 72 ft. and has self-supporting steel frames covered in with corrugated sheeting. The head room to the underside of the roof trusses is 21 ft. The roof consists of 2-inch matched sheeting covered with tar gravel, and the floor of 4x6 in. red pine planks laid on 4x4 in. stringers. The latter, spaced at 3 ft. centres, are bedded in cinders. The building runs east and west and has six roof monitors running at right angles to this direction. The reason for the latter feature lies in the fact that the building will eventually be extended in a northerly direction and the monitors will then form the principal source of light for the centre of the shop; hence the importance of having them run east and west.

Each of the roof trusses in this shop has been designed to carry two 5-ton air hoists and there are also three lines of beam runways running longitudinally and equipped with 3-ton chain blocks. In addition there is a 15 ft. runway for

four 3-ton hand operated travelers on the north side of the shop.

This structural shop contains all the heavy machines, as will be later detailed.

frames and large steel sash windows. The south side is of brick up to the window sills, but the other three sides are merely covered in with corrugated sheeting to allow of future extension.

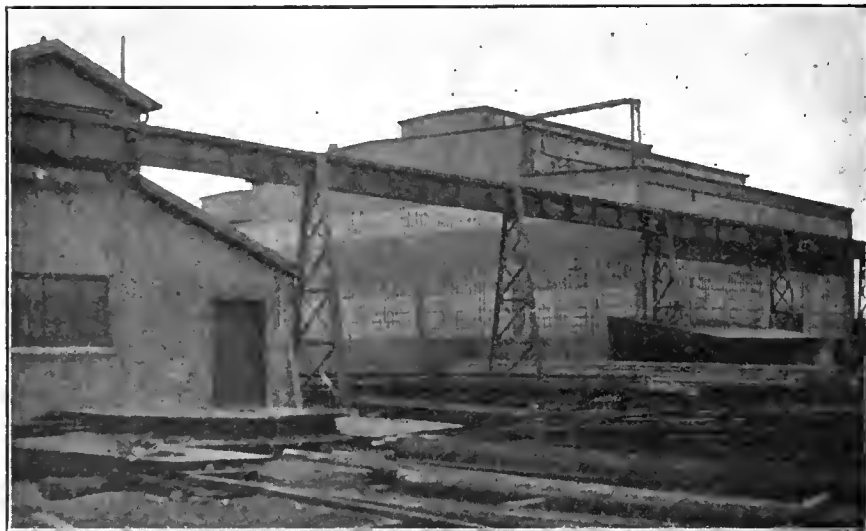

FIG. 2. VIEW OF STOCK YARD AND EAST END OF STRUCTURAL SHOP.

Girder Shop.

The third building forms the girder shop and stands between, and to the west of, the other two. Like the structural shop, it has self-supporting steel

This shop measures 260 x 63 ft., with 32 ft. 6 in. of head room under the trusses. It is served by two 30-ton Royce 3-motor traveling cranes of 59 ft. span, in addition to which a runway has



FIG. 3. INTERIOR OF STRUCTURAL SHOP LOOKING WEST. IN THE FAR CORNER IS SEEN THE 80 FT. OPENING INTO THE GIRDER SHOP. ILLUSTRATION SHOWS LONGITUDINAL TRAVELLERS FOR RIVETERS AND AIR HOISTS RUNNING CROSSWAYS ON LOWER CHORDS OF ROOF TRUSSES.

been provided along the north side for 10-ton wall cranes. Two of the latter have already been installed and are used for carrying the heavy pneumatic gap riveters.

An interesting feature of the building is an 80 ft. steel truss, which spans the opening from the structural shop. This truss is of the lattice type and is 17 ft. 3 in. deep. In addition to carrying the weight of 65 ft. x 80 ft. of roof, it also supports three 5-ton air hoists and the runway for the 30-ton cranes in the girder shop. This 80 ft. opening has a head room of 22 feet and allows ample room for transferring large members from the structural shop.

A standard gauge track runs in at the west end of the girder shop, enabling the 30-ton cranes to load the heaviest members direct on to flat cars. All shops are fully served by industrial tracks of 30-inch gauge.

Raw material is taken from the stock yard at the east end of the shops and passes through step by step to the west

at present temporarily located in the girder shop, but will eventually be re- an 84-in. gate shear with capacity to 17-in. plate, by the Canada Machinery



FIG. 4. GIRDER SHOP, LOOKING EAST. ON THE LEFT MAY BE SEEN THE 80 FT. OPENING FROM THE STRUCTURAL SHOP

moved to the structural shop when the Corporation; a Bertram double ended punch and shear, with 24-in. and 36-in. latter is extended.



FIG. 6. ELECTRICALLY OPERATED BASCULE BRIDGE, WITH 60 FT. DECK PLATE GIRDER SPAN, OVER THE TRENT CANAL AT LINDSAY, ONT.

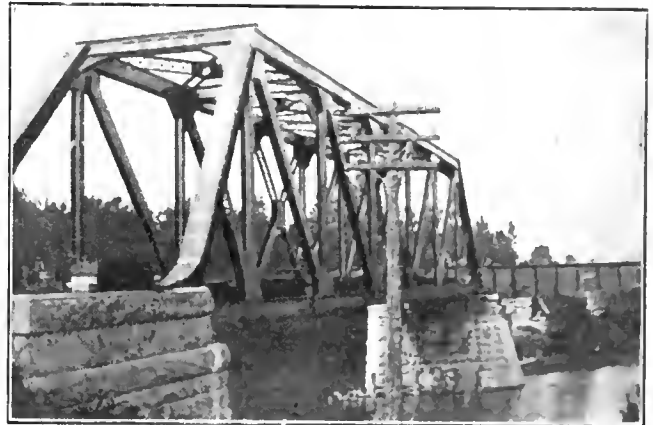

FIG. 7. THROUGH RIVETED LATTICE GIRDER SPAN AND THROUGH PLATE GIRDER SWING SPAN (IN THE DISTANCE), ERECTED OVER RIVER THAMES, AT CHATHAM, ONTARIO.

end of the girder shop, without change of direction. The machine tool equipment is all of the latest type and is mostly contained in the structural shop. At the south-east corner of this shop there is a 5-roll set of combination bending and straightening rolls by Wickes Bros., Saginaw, Mich. These are used for straightening plates as they pass into the shop from the stock yard, and will take stock 11 feet in width. They have two feeding rolls and three bending rolls, and are so arranged that the feeding rolls may be dropped to allow of bending plates for tank work, etc.

Along the south side of the structural shop there is a 42-inch multiple punch by the Canada Machinery Corporation. This is equipped with a Thomas spacing table, which will take any plate up to 75 feet in length and 42 inches in width. There is also a No. 6 bulldozer by Williams, White & Co., Moline, Ill. This is

Further equipment includes a 16-ft. gaps; a 48-in. Hilles & Jones punch; a plate edge planer by Hilles & Jones; Bertram double angle shear, with ca-

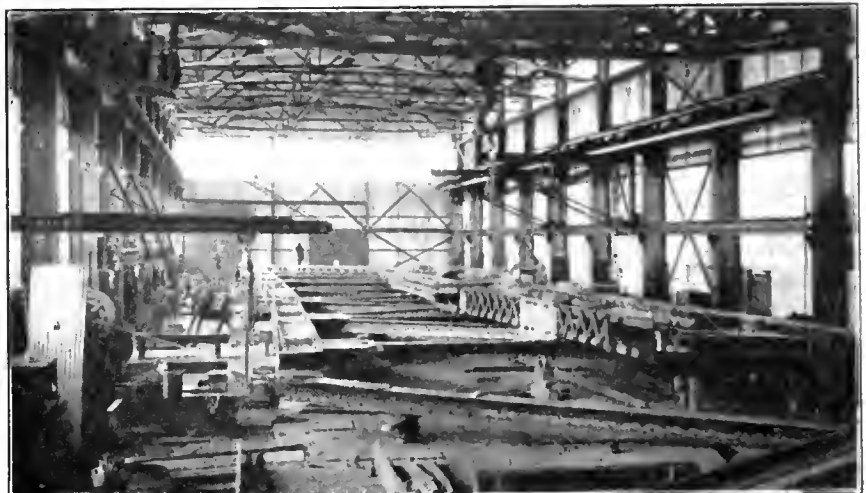

FIG. 5. GIRDER SHOP, LOOKING WEST. HERE IS SEEN UNDER CONSTRUCTION A 210 FT. RIVETED THROUGH LATTICE RAILWAY SPAN.

capacity to 8 x 8 x 1 in. angles; a Pells beam cutter for 24-in. I-beams; and a 52-in. rotary planer with 8-ft. saddle traverse, by the Canada Machinery Corporation. These machines all have individual motor drives and have been laid out to the best advantage for handling the work in the shop. In addition to

the Canadian Ingersoll-Rand Co.'s make.

Power Plant.

Air for these tools is supplied by a horizontal two-stage Bury air compressor, having a capacity of 700 cubic feet of free air per minute. It is belt driven by an induction motor of 125 h.p. The

type being of course used to improve the power factor. This motor-generator set provides direct current for the lighting circuits and for the crane motors.

Artificial lighting in the template shop is by 100-watt tungsten lamps suspended from the roof trusses, with individual drop lights where special illumination is required. The girder shop and structural shop are lighted by Canadian General Electric Co.'s D.C. flaming arc lamps, placed above the bottom chords of the roof trusses.

Progress of Plant.

The site was staked out on October 10, 1911. By January 1, 1912, the brick building now containing the template shop and power house was closed in, permitting the foundations for the air compressor and the electrical equipment to be put in. The steel for the structural shop was built at the company's up-town plant and everything was sufficiently far advanced by May 1, 1912, to start manufacturing.

The first work turned out by the new plant was the steel for the girder shop on which erection work was pushed rapidly forward, so that it was ready for the cranes by August 1. The shop was in complete operation by September 1, since which time the plant has turned out about 2,000 tons of work.

The yard tracks are served by a locomotive crane which has been on the site from the very beginning of operations and greatly expedited the work of erecting the buildings.

Examples of the Company's Work.

Some of our illustrations give an idea of the appearance of the new plant, while others show good examples of work turned out by the company.

Fig. 6 shows a bascule bridge, with 60 ft. deck plate girder span, over the



FIG. 8. DERRICK CAR ERECTING 80 FT. SINGLE TRACK GIRDER SPAN.

the above tools there are a few smaller machines, such as a 48-in. radial drill, 18-in. engine lathe, grinders, etc. These are located along the east end of the girder shop and are driven from a line shaft.

The rivet forges all burn fuel oil. They were supplied by F. Hyde & Co., Montreal, and are fitted with the Jacobs' burner. The latter are at present adjusted to use high pressure air. As the plant is extended, however, a low pressure system will be installed.

The oil distribution system is in duplicate, the piping being laid in iron casings underground. Provision is made for steam heat in winter to prevent the oil from thickening.

Reamers, Pneumatic Tools, etc.

In addition to a number of pneumatic reamers, there are two Van Dorn and Dutton electric reamers. There are also four radial wall reamers in the structural shop and four portable radial reamers in the girder shop. These were designed and built by the company and have their spindles driven by a worm and gear, instead of by the usual bevel gears.

The pneumatic tools include two 48-in. and one 36-in. Hanna riveters; one 24-in. and one 36-in. riveter by the Shepard Electric Crane & Hoist Co.; and one column riveter by the same firm. The air motors, drills, chipping hammers, etc., were supplied by the Chicago Pneumatic Tool Co., while the numerous air hoists throughout the plant are of

compressed air, at 90-100 lbs., is taken to a receiver and from thence by an underground main to a central point in the shops. From here it goes to the roof and is distributed by drop pipes to various points as required.

Power is purchased from the city hydro-electric system, current being received at 2,200 volts and stepped down to 220 volts by three static transformers, each of 300 k.w. capacity. The power plant equipment also includes a motor-generator set of 75 k.w. generator capacity. The generator is direct driven by a 100 K.V.A. synchronous motor, this



FIG. 9. ERECTION CAR PLACING 100 FT. DECK PLATE GIRDER IN POSITION.

Trent canal at Lindsay, Ont. This is an ordinary type of Strauss bascule trunnion lift bridge, but is of interest as being probably the first highway bascule bridge, if not the first bascule of any kind, erected in Canada. During the last two or three years, however, a considerable number of railway bridges of this type have been built.

Fig. 7 shows a through riveted lattice girder span and through plate girder swing span recently erected by the company on the line of the Canadian Pacific Railway over the River Thames at Chatham, Ont. The lattice span is 157 ft., and the swing span 120 ft. in length. Both were specially designed for heavy main line traffic.

Fig. 8 shows a steel trestle on the line of the Georgian Bay and Seaboard Railway,—a branch of the C.P.R. from Victoria Harbor to Burketon Junction, Ont. This was recently erected by the Hamil-

ton Bridge Works Co.'s method of erecting steel frame buildings. The example here shown is a warehouse and paint shop recently put up for the Oliver Chilled Plow Co., of Canada, at Hamilton, Ont. The cut clearly shows the steel traveler by means of which all three bays of the building were erected simultaneously. The total weight of steel in this structure is 1,800,000 pounds, the whole of which was erected in 30 days.

Personal.

The new east end plant is under the supervision of Mr. E. H. Darling, C.E., who is the resident engineer in charge of the design, construction and operation of the plant. Mr. Chas. M. Strubel is shop superintendent. The company's chief engineer is Mr. R. K. Palmer, and Mr. W. G. Milne is plant engineer. The executive officers are as follows:—



FIG. 10. METHOD OF SIMULTANEOUSLY ERECTING THREE BAYS OF A STEEL FRAME WAREHOUSE.

ton Bridge Works Co. over the Skugog River. The illustration shows one tower and span, and also one approach span, erected complete. One of the company's large standard derrick cars is seen in the act of erecting an 80-ft. single track girder span. This is the company's regular method of erecting work of this kind and the cut shows the operation very clearly. The same style of derrick car is seen in Fig. 9, placing a 100-ft. deck plate girder span on the line of the National Transcontinental Railway over the Missinabi River, about 100 miles west of Cochrane, Ont. It will be noticed that the steel structure in course of erection replaces a temporary wooden bridge which had previously carried construction traffic on this line.

Hon. John S. Hendrie, C.V.O., President.

Wm. Hendrie, Esq., Vice-president.

R. Maitland Roy, Esq., C.E., General Manager.

The company were so busy during 1912 on railway bridge work for the Canadian Pacific, Grand Trunk, National Transcontinental, Canadian Northern Ontario Railways that they were able to accept very few orders for highway bridges, structural steel work, etc., but were compelled to confine their attention almost entirely to railway work.

This condition of affairs will be greatly relieved in 1913 by the new plant. Orders on hand ensure the latter being kept busily employed all year.

WESTERN WATER POWERS.

THE Prairie Provinces' water-powers upon which fairly definite information is available are mostly all confined to the southern portion of each. This is a rather unfortunate coincidence, and is likely to mislead the uninitiated regarding the total potentialities of these provinces, as the larger water-powers are situated in the north, on the Athabaska, Peace, Slave, Churchill, Nelson and other rivers.

As even a preliminary survey of these rivers will be of great value, the Commission of Conservation has undertaken this work. During the last two summers, its Hydro-Electric Engineer, Mr. L. G. Denis, has been in the field making measurements of flow, height of falls, etc., and last year the many rapids of the Athabaska River were investigated and the flow of the Peace and other rivers measured. This year, the work included many long miles of travel, mostly by canoe, the western limit of the trip being the Peace River canyon in the north-eastern portion of British Columbia, while the northern limit was Fort Smith, on the Slave River.

On the return trip, the several rapids and falls in the Clearwater River and the upper waters of the Churchill were investigated. The general impression created by these large northern water-powers is that they will undoubtedly become of great value in connection with the wood-pulp industry. The raw material is close at hand, the only retarding factor, at present, being the lack of means of transportation and access. The details obtained by these investigations will be included in the Commission's forthcoming report on the "Water-Powers of Western Canada."

CANADIAN CAR & FOUNDRY CO.

THE third annual report of the Canadian Car & Foundry Co., Montreal, for the fiscal year ended September 30, issued to the shareholders on December 9, shows that the gross sales for the year were \$16,500,000. The profits for the year, available for dividend purposes after providing for the first instalment of the bond sinking fund, as shown by the profit and loss account, were \$1,040,000.

At the close of the fiscal year, the unfilled orders amounted in value to over \$15,000,000, and at the date of the report, the value of unfilled orders is \$16,000,000.

PETROLEUM RESOURCES OF CANADA.

WHILE the actual petroleum resources of Canada are comparatively small, nevertheless the potential resources are considerable.

In New Brunswick and Nova Scotia there are enormous deposits of oil shales which are valuable as a source of oil. On an average, these shales will give a higher yield of crude oil per ton than the oil shales worked so extensively in Scotland.

In the vicinity of Fort McMurray and Fort McKay on the Athabaska River, Alberta, there are enormous deposits of tar sands. The bitumen in the tar sand is the residue from evaporated petroleum, and it has been estimated that there are 6½ cubic miles of solid bitumen in the tar sands exposed on this river. Although enormous quantities of oil have evaporated from this district, nevertheless it is probable that accumulations of petroleum exist where the geological structure was such as to prevent its escape. This is also substantiated by the fact that natural gas occurs in quantity in districts where the tar sands are capped by overlying measures.

If large quantities of petroleum were discovered in Alberta, it would be a factor of great importance to the railway interests which operate in the Rocky Mountains and Jasper Parks, and in other forest areas in British Columbia and Alberta.

Oil as a Locomotive and Marine Fuel.

The Canadian Pacific Railway is now using oil-burning engines on its main line between Kamloops and Field in British Columbia. The Grand Trunk Pacific and some of the Canadian Pacific coast steamships also burn oil, and other boats are being changed from coal-burners to oil-burners. The oil is obtained from the California oil-fields. If supplies can be obtained at the prices now prevailing, its use will be very largely extended. Its cleanliness, the greatly decreased smoke, the decrease in the number of firemen required, the economy particularly in intermittent service, the increased efficiency—two boilers with oil, in steamship service, giving same steam as three with coal—and other considerations, make it an almost ideal fuel.

INDUSTRIAL ACCIDENTS.

ACCORDING to the record of industrial accidents maintained by the Department of Labor, there were 104 workmen killed and 324 injured during the month of October. Compared with the record for September, this is an increase of 15 in the number killed and

a decrease of 95 in the number injured. The greatest number of fatal accidents occurred in steam railway service, there being 28 employees killed. The building trades come next with 18 fatalities. Of the non-fatal accidents, the greatest number occurred in the metal trades, the number recorded being 85, followed second by building trades with 40 injured, and third by steam railway service with 37 injured.

RAILWAY EQUIPMENT PLANTS.

THE larger locomotive plants are all booked up with orders for some time ahead and it was recently stated that at the present time every Canadian company could have additional orders if they could guarantee deliveries.

Since its re-organization in June, 1911, the Canadian Locomotive Co. at Kingston has turned out 90 locomotives, 20 of them being of the consolidation type for the C.P.R., and 25 of the same type for the Canadian Northern.

In the last year, the Montreal Locomotive Works have turned out 425 locomotives, among which were 108 ten-wheelers for the C.P.R., 60 ten-wheelers for the Canadian Northern, 60 consolidated for the C.P.R., and 75 Pacifics for the C.P.R. At the present time the C.P.R. seems to have orders placed in every equipment and locomotive company in the country, and at the same time is operating its plants on day and night shifts.

The difficulty being experienced by the large Canadian railways in getting deliveries of equipment has also resulted in the new companies getting some big orders to fill, just as fast as they can turn them out.

The new National Steel Car Co., of Hamilton, Ont., have already received orders for 1,500 cars, while the new Nova Scotia Car Works have orders on hand for 2,500 cars.

CANADIAN CENSUS OF MANUFACTURES.

THE official statistics of the census of Canadian manufactures for the year 1910, which have been published recently by the Department of Labor, show that the total value of the production amounted to \$1,164,775,532, as against \$718,352,603 for the year 1905. The figures for 1910 include the following items:—Boilers and engines, \$11,873,903; bridges, iron and steel, \$6,502,410; cement, \$5,683,036; electrical apparatus, \$15,021,840; electric light and power, \$12,917,232; foundry and machine shop products, \$45,611,410; gas lighting and heating, \$4,005,836; iron and steel, \$34,613,710; ships and ship repairs, \$5,136,257; and smelting, \$33,669,700.

ANNUAL REPORT, DEPARTMENT OF LABOR.

THE annual report of the Department of Labor notes an upward tendency in wages, attended by an increase in the cost of living. The success of the Industrial Disputes Act is indicated by the fact that in five years 124 disputes in which it was invoked have arisen, and only in 14 cases did the conciliatory proceedings fail to prevent a strike. Last year there were 97 industrial disputes as against 94 in the year previous. Building trades predominated in these difficulties. The report explains and reviews at length the work of the department, an important feature of which is the regular investigation and reports of wholesale prices in relation to the cost of living.

NICKEL PLANTS IN CANADA.

LARGE increases in existing nickel plants and the construction of new ones at Sudbury, Ont., are at present in progress as a direct result of the demand for nickel steel in war material following recent European unrest. Where, two or three years ago, the Canadian Copper Co., the greatest producer of nickel in the world, was carefully nursing the market for fear that the supply would be greater than the demand, it is now buying new ranges and enlarging its operations in an endeavor to supply its orders.

Although it has already large ore resources, the company has just bought part of the Northern range from the Lake Superior Power Co. It is also opening up the Froude mine and other old workings which have been allowed to lie idle for years. Its example is now being followed by other companies. The Mond Nickel Co., which has been shipping small quantities of nickel to England for some years past, is putting up a large and up-to-date smelter, and will carry on operations on a much larger scale. The Dominion Nickel Co. will build a new smelter at Cobalt. This company has for years held valuable properties such as the Whistle and Murray mines, but only lately has the market for the ore broadened enough to warrant it to enter into competition with such a formidable competitor as the International Nickel Co. M. J. O'Brien, Renfrew, Ont., and J. R. Booth, the Ottawa lumberman, are the principal stockholders in the new company.

Mr. Russell Medland, formerly manager of the Toronto branch of the General Supply Co. of Canada, Ltd., is now resident in Winnipeg, having charge of the company's Western business.

Point du Bois, Winnipeg, Hydro-Electric Power Station

Through the courtesy of Mr. J. F. I. Thomas Montreal, Canadian representative of Vickers, Ltd., Sheffield, England, we are enabled to publish this comprehensive descriptive article on the constructional and equipment features of the above installation, and believe that our readers will find it both interesting and instructive.

THE purpose of this article is to give a description of the new hydro-electric station which has been built to supply electric power to the city of Winnipeg. The station, the designs for which were put in hand in 1906, was completed in the latter part of 1911 and is now in operation. The supply system, of which the station forms a part, is a new one and will not be worked in conjunction with the earlier system of the city, but in competition therewith, since the new system is a municipal one, while the earlier is in the hands of a company.

The new station is situated at the

Location Features.

The Winnipeg River, with its tributary the English River, has a watershed of some 52,000 square miles, situated in Northern Minnesota, North-West Ontario and Eastern Manitoba. The average rainfall in the area is from 18 in. to 25 in., and the river flow at the Point du Bois Falls was 16,000 cub. ft. per second as a minimum and 55,000 cub. ft. per second as a maximum during the years 1907 to 1910. Old flood-marks suggest that flows of 90,000 to 100,000 cub. ft. have been reached. On the whole, however, the flow is very uniform

in the formation of a reservoir of 6,000 acres in extent, which gives such ample storage that there is no fear that the station will not be able to meet all demands for power during any season. It is estimated that the water supply will allow of the generation of an average of 65,000 horse-power for twenty-four hours at all times.

Power Station Site.

The site of the power-station, and the general plan of the works carried out at Point du Bois, are shown in Fig. 1. It will be seen that the river falls over two

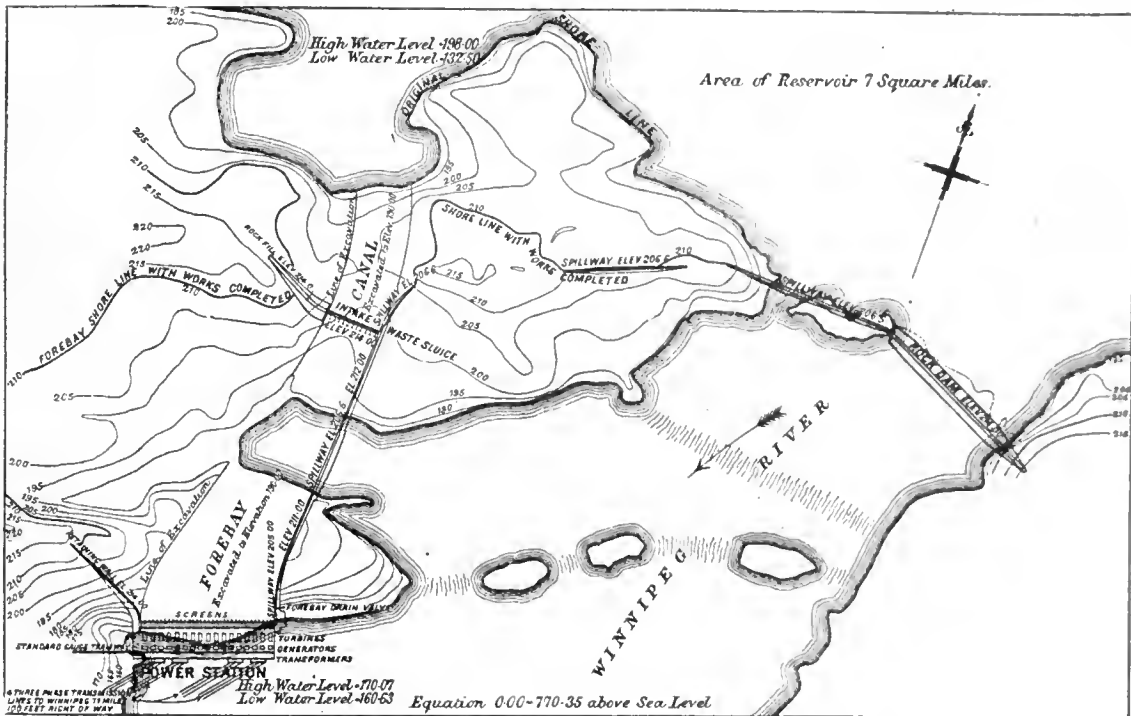

FIG. 1. PLAN OF WORKS AND POINT DU BOIS FALLS.

Point du Bois Falls, on the Winnipeg River, some 70 miles from Winnipeg, so that the electrical scheme includes not only the power-station, but a 77-mile transmission line and a terminal station in the city, in addition to various sub-stations and the distribution network. The power-station machines generate current at 6,600 volts, which is stepped up to 72,000 volts for the transmission lines. At the terminal station, this pressure is stepped down to 12,000 volts for distribution to the sub-stations, at which it is further reduced to 2,200 volts and 550 volts. The 12,000-volt distribution to the sub-stations is carried out by underground cables, while the lower pressure distributing network is both overhead and underground.

as compared with other Canadian rivers, this state of affairs being largely accounted for by the large amount of virgin forest land and the great number of lakes in the watershed. The total lake area is 5,650 square miles, the largest lake of the district—the Lake of the Woods—through which the river flows, having an area of 1,200 square miles.

There are no falls of great height on the river, the total fall, in a distance of 347 miles from the mouth at Lake Winnipeg, averaging about 2 ft. per mile. The natural fall at the Point du Bois was from 28 ft. to 33 ft., but on the construction of the power-house this fall was increased to from 43 ft. to 47 ft. by building dams and drowning out smaller falls upstream. The dams have resulted

natural rock barriers in its passage round the Point du Bois, and that by building a rock dam and spillway across the narrowest part of the stream, the level of the water above the falls has been raised to form the reservoir. As before stated, the natural level has been raised sufficiently to drown out some smaller falls up stream. The building of the dam and spillway is the only interference that was necessary with the river-bed proper, as the supply to the power-station has been arranged for, by cutting a forebay canal on the western side of the river and across the base of the point.

As will be seen from the figure, the canal intersects an arm of the original river, and a spillway from the forebay

has been constructed, communicating with the downstream side of the rock dam. The eastern side of the forebay canal is in the main formed by a retaining wall. In addition to the two spillways already mentioned, there are two situated on the land originally dry, one running approximately east and west across stream, and the other being situated in the canal wall above the intake. The total length of these spillways, or weirs, is 1,500 ft. The crests of the weirs are 7 ft. 4½ in. below the normal water head of the reservoir. The whole of these spillways, together with the the canal retaining walls and the wing wall to the western side of the power-station, were built in concrete. A general view of the forebay canal and other work is given in Fig. 3.

The position of the power-station is shown in Fig. 1, while details of its construction are given in Figs. 4 and 5.

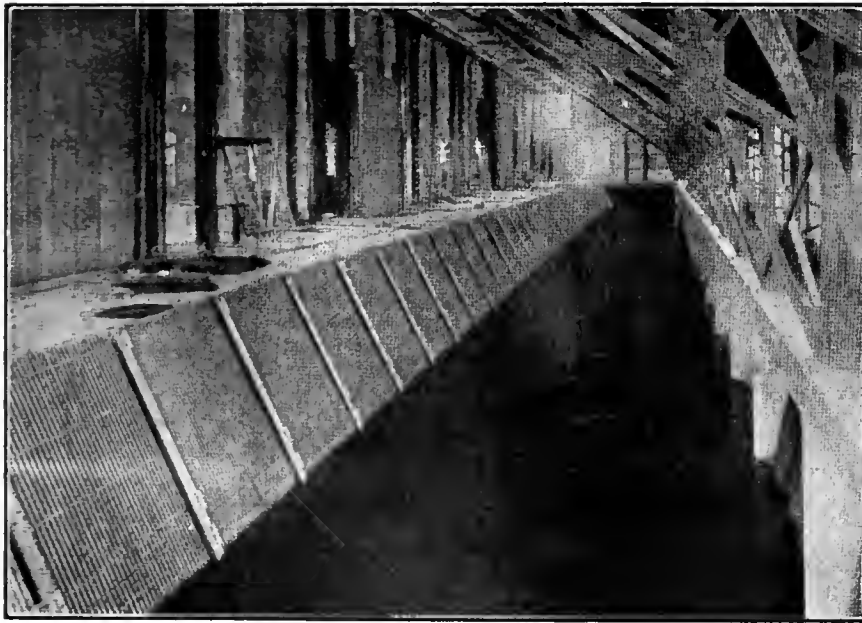

FIG. 2. VIEW OF SCREENS.

The building, which is constructed almost entirely of concrete and steel, has its foundations directly on the natural granite which forms the site. On its north side an upward sloping reinforced concrete apron has been built on a series of supporting walls. This apron, which is 18 in. thick, serves to control the direction of the water in its path into the station, and in addition acts as a gravity dam. The water screens are carried above this apron, as shown in Fig. 5. A view of these screens is also given in Fig. 2. The apron is tied to the wheel-pits on its south side, and these in turn are connected up to the tailrace walls. The wheel-pits, galleries and roofs of the building are made of reinforced concrete. The main walls are of plain concrete.

Station Arrangement.

The general arrangement of the station, and the passages through which the water reaches and leaves the turbines, will be clearly seen from Figs. 4 and 5. The water enters the wheel-pits through inlets, 16 ft. by 20 ft., which have rounded piers between them, and passes on its way through the screens, 45 ft. long and set in a slope as shown. The screens are made in 7-ft. bays, and are supported by sets of three struts, which are attached to a common foot-plate. This arrangement was adopted as offering the minimum of resistance to the flowing water. The head-gates are situated between the racks and the wheel-pits. They are made with a steel framework covered with pine sheathing. The turbine exhaust-passages are 10 ft. by 15 ft., of oval section at the point of intersection with the turbine-pit floor, and expand to 13 ft. by 23 ft. at the

point of outlet. As the head under which the turbines work is of moderate height only, a very large amount of water has to be dealt with, and considerable attention was accordingly required in connection with the question of the velocity of the water in the various parts of the plant. The station will ultimately have a capacity of 60,000 horse-power; and under full-load conditions with such an output, the water would have a velocity of 6.4 ft. per second through the intake in the fore-bay canal. As the canal gradually widens towards the power section, the water would decrease in speed, and pass through the outer piers of the gate-room at 1.5 ft a second. It would then increase to 1.7 ft. a second through the screens, 2.8 ft. a second through the

wheel-pit inlets, and 20 ft. a second through the turbine runners. It would then decrease to 8 ft. per second through the neck of the exhaust-passage, and to 3.3 ft. a second, as this passage gradually increases in area.

Plant Capacity and Equipment.

As stated above, the station is arranged to ultimately accommodate 60,000 horse-power, but at present less than half this capacity has been installed, and only half the station has been built, with the exception of the apron and other portions of the north face, which have been completed as shown in Fig. 4. In view of the moderate head and the very large amount of water which would have to be passed through each unit if a very large size had been chosen, it was decided to instal two-runner turbines of 5,200 horse-power coupled to 3,000 k.w. generators. These units, at 45 ft. head, each pass 1,250 cub. ft. of water per second at maximum output. They run at 164 revolutions per minute. With this output, the water velocities stated are reached. Although the load which the station is to take would have justified units of 60,000 k.w. output, which could have been arranged for by installing four-runner units, it was considered that the very large water passages necessary would be undesirable, and 3,000 k.w. units, were finally decided on. The electrical apparatus in the station is arranged so that three of the 3,000 k.w. units shall normally run together and act as a single unit of 9,000 k.w. The ultimate installation will consist of five of such 9,000-k.w. units and one spare generator, the present installation consisting only of five 3,000-k.w. machines. This feature of the station will be referred to again when dealing in detail with the turbines and electrical gear.

Machines Testing Arrangements.

An interesting feature in connection with the turbines is shown in Fig. 4. This has reference to the arrangements which have been made for testing the machines. It will be seen that, commencing from the right-hand side of Fig. 4, there are six wheel-pits, which make up the first two 9,000-kw. units, and that there is then a single wheel-pit next to the space which is filled by the exciter turbines. This single pit is used for the testing of any machine, and is arranged with a special cast-iron frame above the exhaust passage, on which a machine can be set and lined up. The test is carried out by measuring the water actually passing through the turbine, the power output being, of course, obtained from the electrical end of the set. The water is measured by means of a rectangular flume, which has been built as an extension to the tail-race of the wheel-pit in

question, and which can be clearly seen in Fig. 4.

The amount of water passing through the flume is calculated from the velocity, which is ascertained by observing the movements of a vertical close-fitting diaphragm which hangs from a raft floating in the flume, and is free to move with the current. The walls of the flume are built of concrete, and in them flush oak blocks are set, carrying electrical contacts. There are three pairs of contacts—the first close to the power-house, the second 4 ft. 6 in. away from these, the third 25 ft. 9 in. away from the sec-

with the contacts, so that a measure of its outward velocity, and so of the velocity of the water, is secured. The diaphragm is provided with a pointer projecting above the raft, this pointer indicating when it is vertical, so that if it is still in an inclined position when it passes the first pair of contacts, the reading from them is ignored and the time-interval between the second and third pair of contacts only is considered. This testing appliance was installed to the designs of the firm which supplied the turbines, the Canadian Boving Co., Bay St., Toronto.

through motor-driven nuts placed in the gate motor-room. The lifting motors drive horizontal shafts, and are arranged with clutches, so that one motor can lift any one of four gates. Stop-logs are arranged to be placed between the water-screens and the gates, if necessary, to serve as an alternative method of cutting off the water supply, or for use when it is desired to work in the gates. The turbine and generator-rooms are each fitted with traveling cranes as shown, while the distribution of the electrical gear will be clear from the figures.

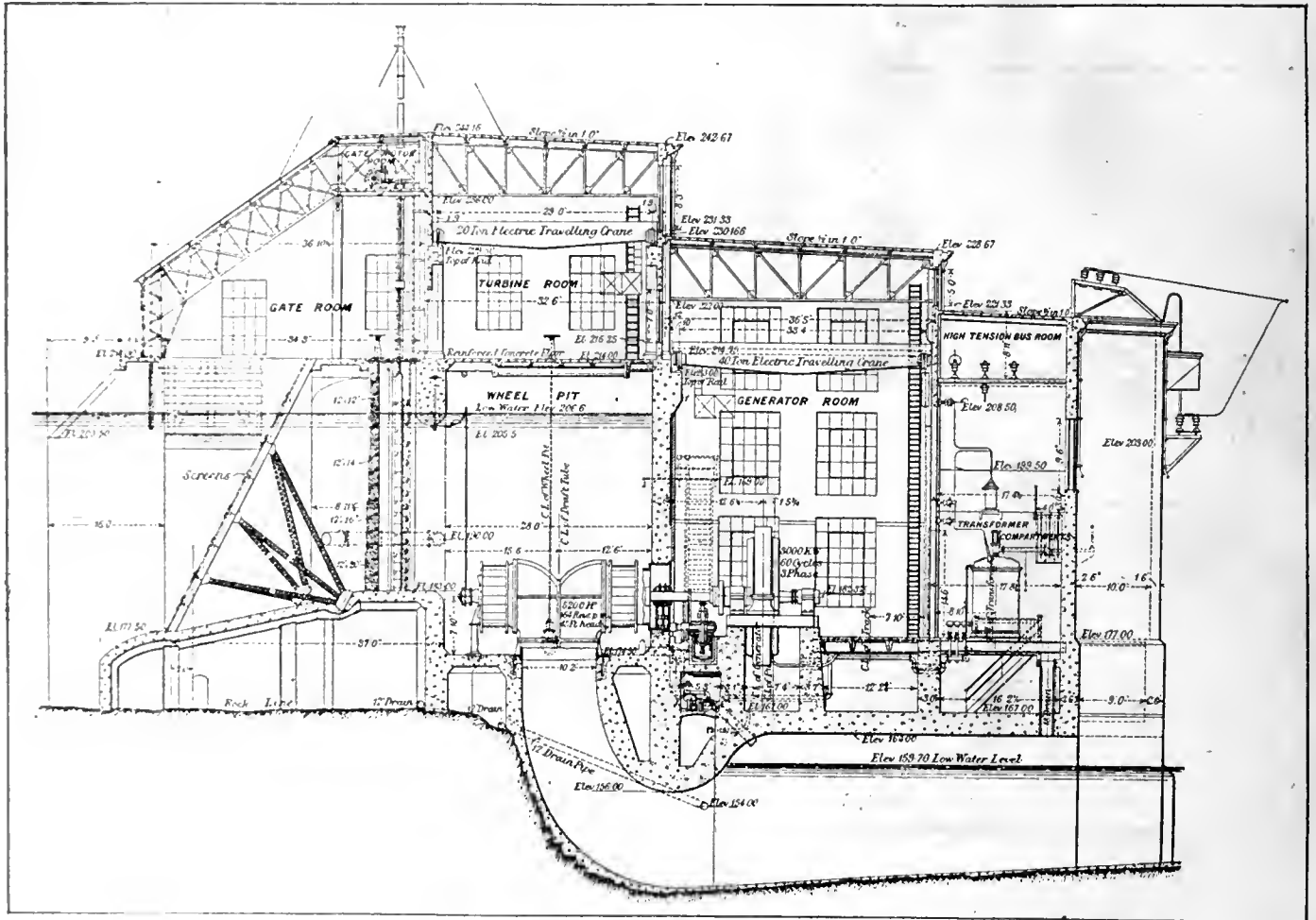

FIG. 5. CROSS SECTION THROUGH POWER STATION.

ond, and the contacts are arranged in connection with electrical gear which records the instant at which the diaphragm passes each pair of contacts.

When testing a machine, the raft is drawn up close to the power-house wall, and held there until the load on the machine is constant and everything ready for the test. During this time, the diaphragm takes up an inclined position, owing to the discharge water passing under it. At a set time, the raft is released, and the diaphragm, falling by its own weight, is at the same time carried forward by the stream of water. On its passage forward it makes connection

Arrangement of Equipment.

The general arrangement and the distribution of the plant in the power-station will be easily followed from Figs. 4 and 5. It will be seen that the building is divided longitudinally into four parts, containing respectively the water-screens, the turbines, the alternators, the transformer and switch-gear, and that annexes are built on the south side to hold the lightning-arrestors and outgoing-line connections. The head-gates work on rollers, and are lifted by means of vertical screws 40 ft. long, which rise

Turbines Detail.

As stated in the previous part of this description, the station is equipped with 5,200 horse-power turbine units coupled to 3,000-kw. alternators, which generate three-phase current at 60 cycles and 6,600 volts. The turbines were supplied by the Canadian Boving Co., Bay street, Toronto, and the alternators by Messrs. Vickers, Ltd., of River Don Works, Sheffield. The turbines are of the two-runner type, and their general lines will be followed from Figs. 6 to 13. The main casings are of cast iron, and are carried by oval castings, which are

The arrangement of the gate-shutters can be followed from Figs. 6 to 9.

The operating shafts are connected up by links to rings which lie on the outside of the wheel casing, and which are in turn attached by short links to the

driven by a pair of oil-cylinders, acting in conjunction with the governor gear.

Governor and Gate Operating Gear.

The whole of the governor and gate-operating engine arrangements are situated in the alternator-room, as shown in

by means of a belt from the turbine shaft, as indicated by dotted lines in Fig. 12, and as shown in plan in Fig. 7. The oil-pump supplies oil to the cylinders through the intermediation of valves, which are controlled by the governor.

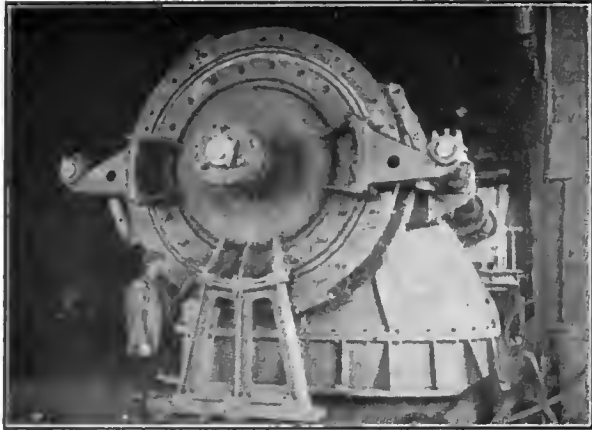

FIG. 8. VIEW OF TURBINE FROM OUTER BEARING END.

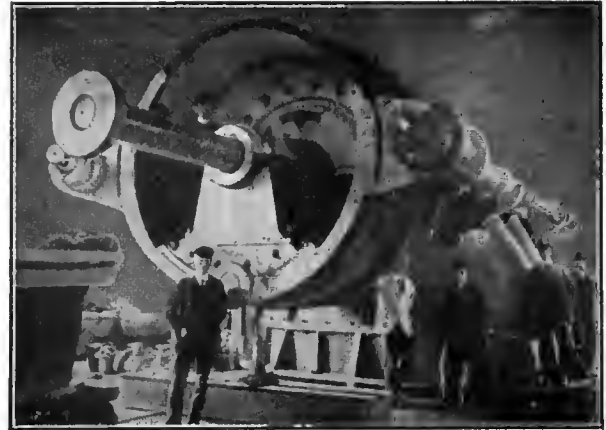

FIG. 10. VIEW OF TURBINE FROM ALTERNATOR END.

shutters, as shown in Fig. 9. The rotation of the gate-shafts rotates the rings, so that the shutters can be opened or closed. The shafts are operated by means of the crank-and-link mechanism shown in Figs. 12 and 13, which is

Figs. 6 and 7. The operating engine is best seen in Fig. 12. It consists of two vis-a-vis cylinders, supplied with oil from a pump situated in the lower part of the oil reservoir, shown at the left-hand side of Figs. 12 and 13, and driven

These valves are shown at the right-hand side of Fig. 12. This figure also shows the connecting pipes between the oil-pump, the valves, and the cylinders.

The mechanism operates by means of a balanced valve, which is connected up

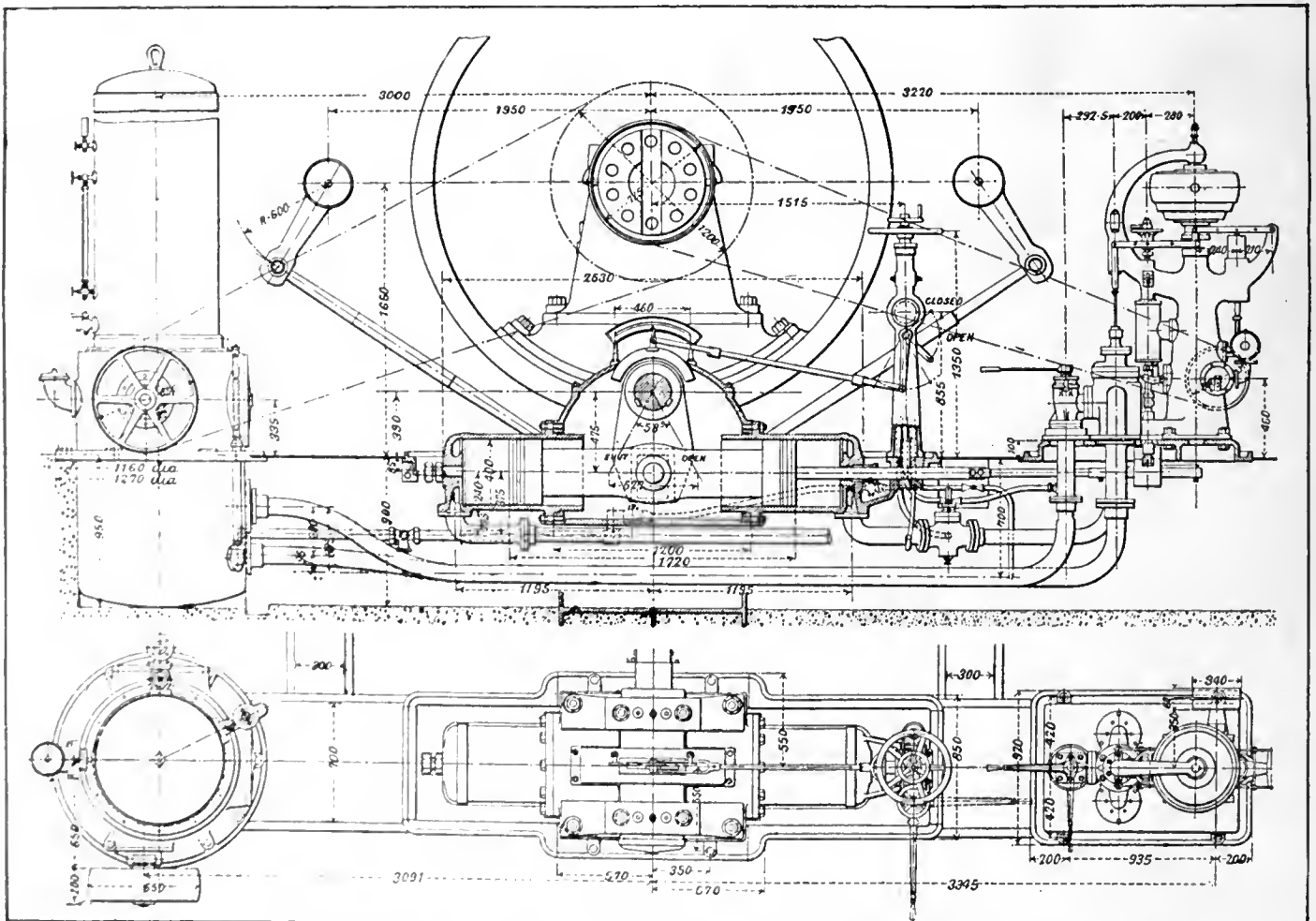

FIGS. 12 AND 13. VIEWS OF GOVERNOR GEAR AND GATE-OPERATING ENGINE.

The position of these exciters can be well seen in the plan of the station which was referred to in the earlier part of this des-

cription and will be found in Fig. 4. While views of the exciter turbines are these figures, the turbines are not set in wheel-pits as are the larger machines, but they have been provided with outer

are carried through the wall into the gate-room.

Shut-off valves are fitted on these pipes, as shown in Fig. 19. The turbines themselves are substantially the same as the larger units, but have two bearings only, as shown in Fig. 14. Speed control is obtained by shutter gates, exactly as in the larger machine, and the gates are operated by oil-cylinders controlled by the governor, as before. One of the exciter governors is shown in Fig. 18. As will be seen in Fig. 14, and in some of the other figures, fly-wheels have been adopted on these small turbines, owing to the insufficient fly-wheel effect of the exciter armatures to which they are coupled.

Alternator Features.

The alternators, as before stated, were supplied by Messrs. Vickers, Limited, of River Don Works, Sheffield. They are of the firm's standard horizontal-shaft rotating-field type, and have each an output of 3,000 kw., or 3,750 k.v.a., at 0.8 power-factor. They give 6,600 volts and 60 cycles at 164

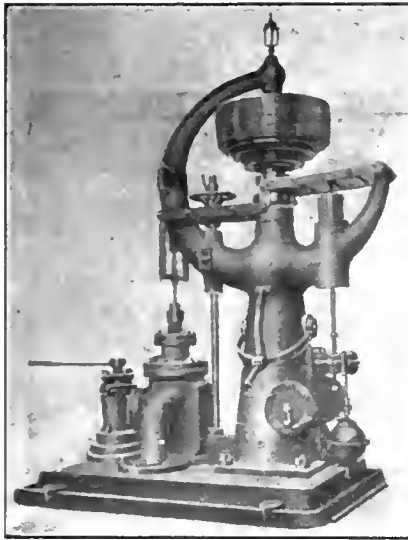

FIG. 17. MAIN GOVERNOR.

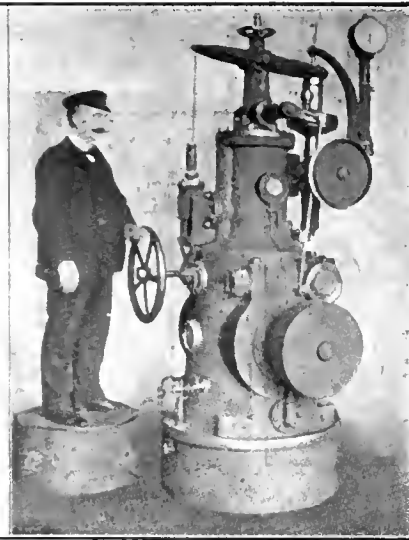

FIG. 18. EXCITER GOVERNOR.

criptions, on to which supply-pipes are fitted. The turbines are situated in a

special bay, built between two of the main wheel-pits, and the supply-pipes

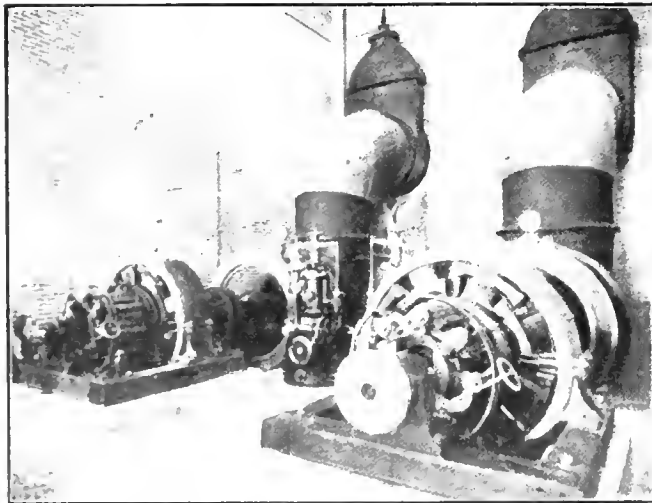

FIG. 19. VIEW OF EXCITERS.

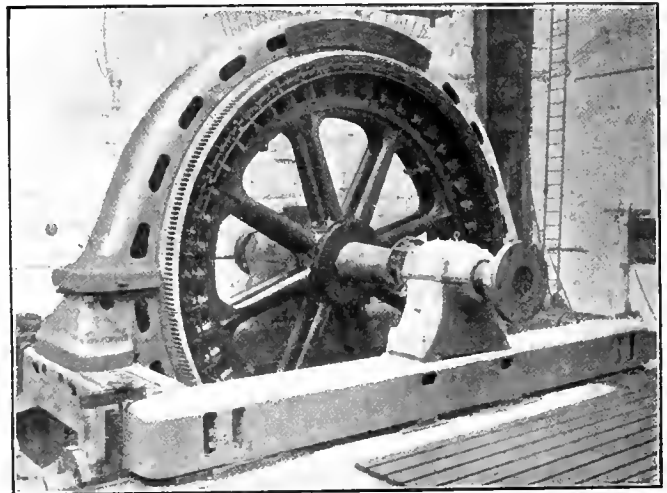

FIG. 20. VIEW OF 3,000 K.W. ALTERNATOR IN BUILDERS' WORKS.

given in Figs. 14 to 16, and a general view in Fig. 19. As will be seen from

special bay, built between two of the main wheel-pits, and the supply-pipes

revolutions per minute. The specification for the alternators called for a

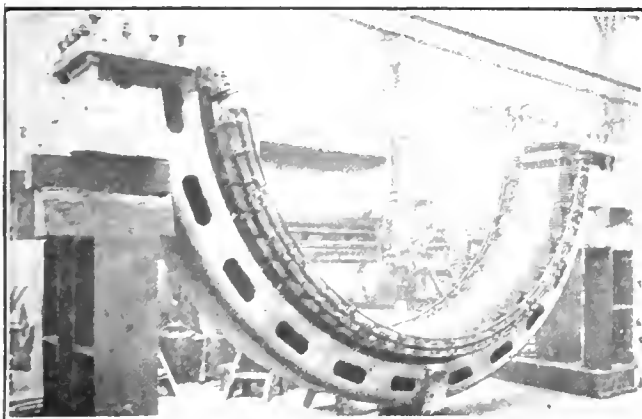

FIG. 21. VIEW OF LOWER HALF OF STATOR OF 3,000 K.W. GENERATOR.

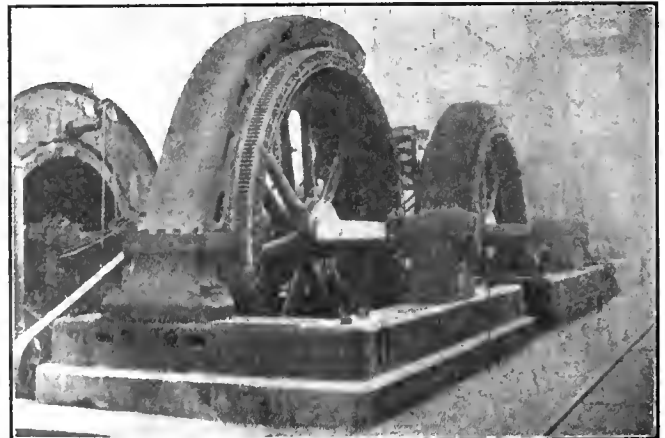

FIG. 23. GENERAL VIEW OF ALTERNATOR ROOM.

temperature rise of not more than 63 deg. Fahr. after 24 hours' full-load run, and not more than 99 deg. Fahr. rise after a 10 hours' run at 3,450 kw. (7,600 volts), and also not more than 81 deg. Fahr. rise after two hours at 3,750 k.w. following the 24 hours' test. All these conditions were easily met by

short-circuited without any signs of injury. The regulation of the machine on test was 8.5 per cent. at unity power-factor, and 22 per cent. at 0.8 power-factor.

Fig. 20 shows one of the machines erected in the builders' works, while Fig. 21 shows the lower half of one of the

moulded mica, and secured in their slots by hard-wood wedges. The projecting ends are anchored by mica-insulated bolts and distance pieces, the outer ends of the bolts being fixed to a complete ring which forms part of the guard covering the high-tension winding. The rotors are built up each of two cast-steel wheels pressed on to the shaft and carrying 44 laminated poles, keyed and dove-tailed in position. Each pole is wound with bare copper strip on edge, with waterproof insulation between the turns, while bronze wedges are placed between the windings to prevent lateral displacement. Lubrication is by means of oil rings.

The exciters, which are two in number, were also supplied by Messrs. Vickers. They are of the firm's standard eight-pole shunt type, of 250 kw. capacity, and run at 400 revolutions per minute, giving 125 volts. They are illustrated in Fig. 19, and, as this figure shows, are driven by special water-turbines, as before mentioned. The voltage control of the alternators is looked after by Tirrill regulators, which act on the field of the exciters, and are set to compensate for line drop. On the completion of the station, two further exciters of similar capacity with those described above will be installed, but of a motor-driven type. The tests of the alternators and exciters were supervised by Messrs. Kennedy and Jenkins before despatch of the machines from England.

Operating Features.

As already mentioned it is intended that the 3,000-k.w. generators shall ultimately be operated three together, in the

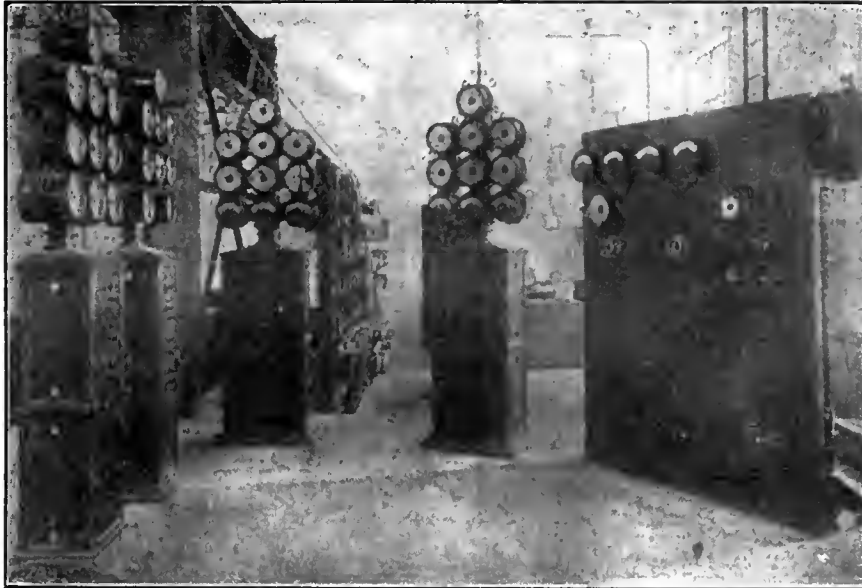

FIG. 24. SWITCH CONTROL PEDESTALS.

the machines, and as it was found that at full gate the turbines could drive the alternators at greater output than had been specified, a test was made at 4,220 kw., under the conditions of which the temperatures did not exceed the maxima allowed.

The tests also included a runaway speed test for 15 minutes at 70 per cent. over-speed, the field being fully excited. Under these conditions the machine was

stators. Figs. 22 and 23 are views taken after the erection of the machines in the power-station. It will be noted from the engravings that the stator frames have been made each in quarters for ease in transport. The figures also show the arrangements which have been made to allow the stator to be racked over for the inspection of the windings or for repair. The stator windings consist of former-wound coils insulated with

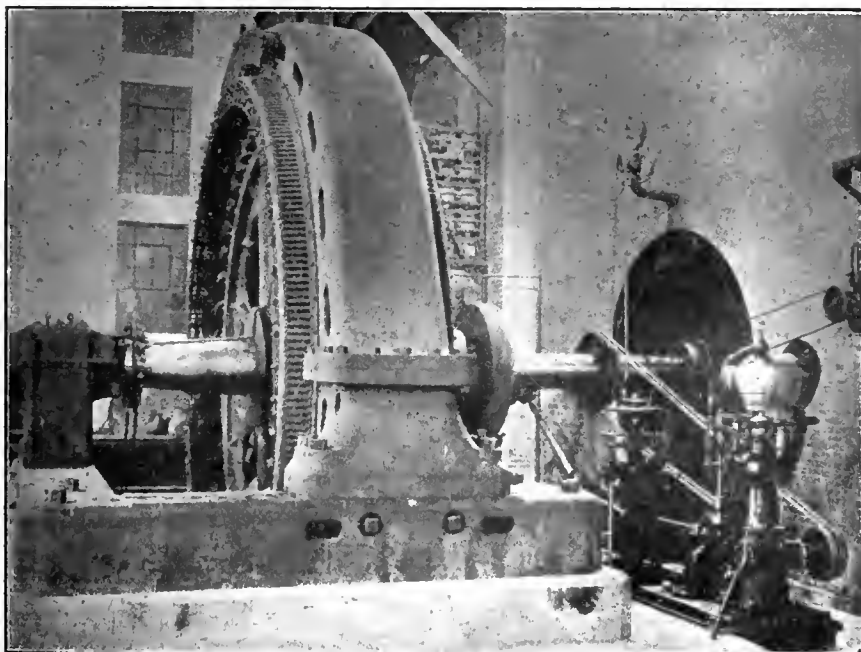

FIG. 22. VIEW OF 3,000 K.W. ALTERNATOR, SHOWING TURBINE GOVERNOR GEAR.

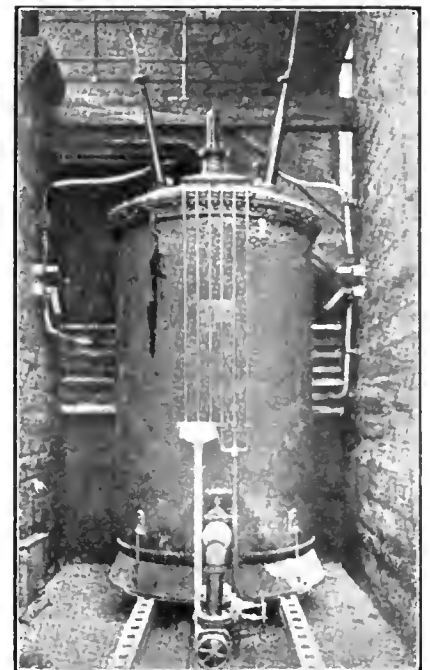

FIG. 27. 3,000 K.W. OIL-IMMERSED WATER-COOLED MAIN TRANSFORMER

form of 9,000-kw. units. The ultimate lay-out of the station as will be seen from Fig. 4, allows for sixteen generators, so that there will be five 9,000-kw. units and one spare generator. At the present time, the whole of the apparatus is fitted for two 9,000-kw. units, with the exception that only five machines are installed. The banks of three machines are

to be ultimately pumped into the supply tank. If, however, the oil after reaching the "good" oil tanks is found still to contain too much moisture, it can be passed again, or as often as desired, through the dehydrator before being lifted to the supply tank.

The transformers have an efficiency of 98.7 per cent. at full load, and a regu-



FIG. 25. 6,600 VOLT MAIN SWITCHES.

arranged to work in conjunction with banks of three transformers, each transformer being of the single-phase type and of 3,000-kw. capacity, the three being connected in delta. The transformers are of the oil-immersed water-cooled type, and are situated in independent concrete compartments which are shut off from the alternator-room by iron doors. The arrangement is clearly shown in Fig. 4. A view of one of the transformers is also given in Fig. 27. The transformer casings are of boiler-plate set on cast-iron bases, and the water-cooling coils are of brass.

Transformer Oil Treatment.

A very complete system for the treatment of the transformer oil is fitted in the station. It consists of filters, a dehydrator, pumps, tanks, and the necessary piping. The oil is received at the station in iron drums, and is at first allowed to flow into the "good" oil tanks by gravity. From thence it is lifted by a pump into a 1,500-gallon supply tank, from which the transformers are filled. "Bad" oil from the transformers is allowed to flow into the "bad" oil tanks by gravity. From these tanks the oil is pumped through a centrifugal-type separator and afterwards through the dehydrator, from whence it enters the "good" oil tanks,

lating of 4 per cent. at 0.8 power factor, and 1.1 per cent. at unity power factor. The temperature rise at full load is 35 deg. Cent. above that of the entering cooling water. The transformers are wound for 6,600 volts on the primary side, and will normally step up on a 1 to 10 ratio; tappings are, however, provided which permit a range of secondary voltage of from 53,000 to 72,000.

Switching Arrangements.

The switching arrangements consist of 6,600-volt oil-switches for both the alternators and transformers, and 72,000-volt oil switches for the secondary slides of the transformers for the out-going lines and for bus-bar coupling. The switches are placed in compartments formed between the banks of transformers, the 6,600-volt gear being on the alternator-room floor level, and the 72,000 volt gear above. The 6,600-volt bus-bars are in duplicate, and run along the ceiling above the oil-switches. They are of copper strip, and are separated from each other by concrete barriers. The 72,000-volt bus-bars are of $\frac{3}{8}$ in. copper tube, and are carried in a special bus-bar room in the upper part of the transformer compartment of the power station. There are no barriers between these bars; the minimum distance from phase to phase is 4 ft., and the minimum distance from phase to earth 2 ft.

The gear contains the various necessary isolating switches and instrument transformers, and leads are run in connection with isolating switches on the 6,600-volt side in such a way that a transformer in one 9,000-kw. unit can, if necessary, be connected in another. The general lay-out of these switch-gear and transformer arrangements can be seen in Figs. 4 and 5. Views of the 6,600-volt oil-switches and the 72,000-volt oil-switches are given in Figs. 25 and 26 respectively.

The connections from the outgoing feeder switches to the overhead lines are carried through special compartments, which are built out as annexes to the station, as shown in Figs. 4 and 5. The three compartments for one three-phase circuit occupy a length of the

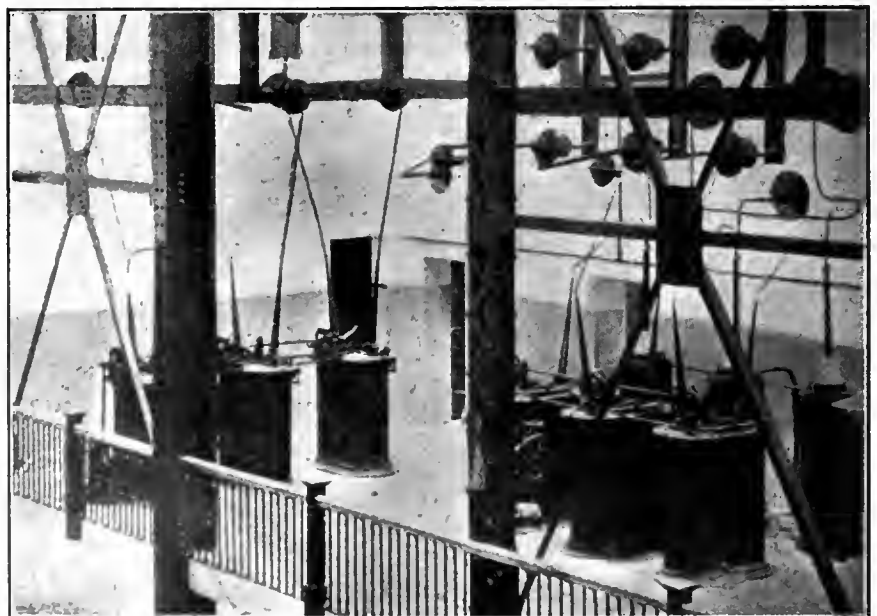

FIG. 26. 72,000 VOLT MAIN SWITCHES.

building which covers two tail-races. This length is actually 56 ft., being somewhat liberal for the apparatus which has to be housed; but the arrangement adopted gives a simple and convenient lay-out. Each compartment is fitted with an electrolytic lightning arrester and horn-gap for its corresponding overhead connection, while, in addition, there is a set of horn-gaps on the roof alongside the wire anchorages. The high-tension wires enter the compartments through reinforced-concrete hoods

apparatus for a 300-kw. 6,600 to 250 or 125-volt transformer, which is used mainly for lighting. This transformer is shown in Fig. 28.

In addition to the firms already mentioned in connection with the turbines and alternators, it should be mentioned that the whole of the transformers and switch apparatus were supplied by the Canadian Westinghouse Co., of Hamilton, Ontario. The consulting engineers for the station were Messrs. Smith, Kerry and Chace, while the whole scheme

reported a greater exchange of commodities than ever before had been known.

The new figure will establish a record, for it is four billion dollars greater than the trade in 1910 and more than double that done in 1890, twenty-two years ago. Seventy leading countries furnished their figures to the government statisticians. Only Argentina and Russia reported decreases, both falling off sharply. The United States so far has shown a monthly increase of \$18,000,000 over 1911. Canada, Hayti, Honduras and Santo Domingo do most of their shopping in the United States, according to the report, while China, India, certain of the Balkan States and Turkey look elsewhere for their purchases. The balance of trade (that difference of goods sold over those imported) still remains strongly with American manufacturers and producers, the figures showing that they enjoyed a balance on the right side of the ledger of approximately \$16,000,000.

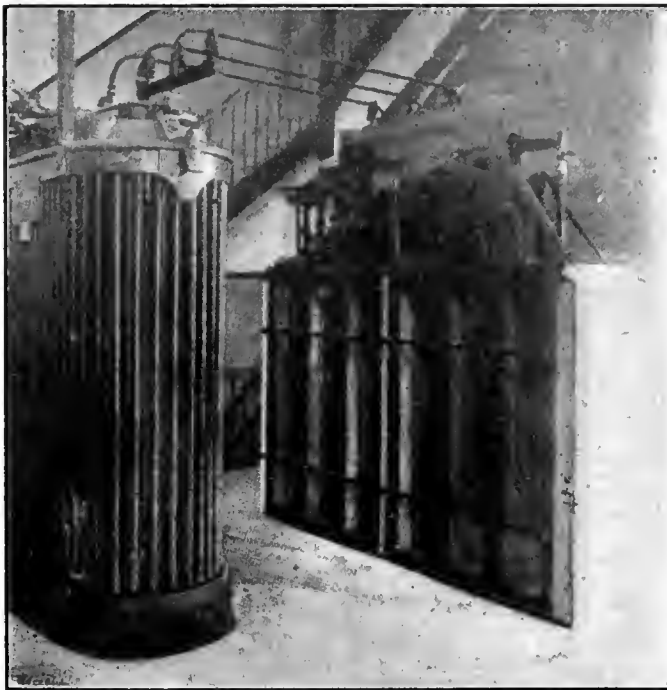

FIG. 28. 300 K.W. OIL-IMMERSED AUXILIARY TRANSFORMER.

which are suspended from the outer walls, as shown in Fig. 5. These hoods are open at the bottom, and on the side next to the building have special insulators, through which the wires enter the compartments.

Switch Gear Control.

The whole control of the switch-gear is looked after from a control gallery, which occupies what will be a central position in the completed station. This gallery contains the various indicating and recording instruments used, together with the small control-handles of the oil-switches, which are all electrically operated. The machine rheostats are also electrically controlled from this gallery. The instruments and control-handles for the main units are arranged on pedestals, as shown in Fig. 24, in order that confusion between the various sets will be less likely. The control-gallery also contains an excitor-board and gear for the operation of a 120-ampere-hour, 65-cell battery, which is used as a stand-by for lighting or for exciter or auxiliary service. There is also control

was in the hands of an advisory board appointed by the Winnipeg Corporation, and consisting of Professor Herdt, of McGill University; William Kennedy, Jr., of Montreal; and Colonel Ruttan, of Winnipeg.

A paper read by Mr. W. G. Chace before the Canadian Society of Civil Engineers together with data, photos and drawings supplied by Messrs. Vickers, Ltd., and the Canadian Boving Co., have we understand, contributed to the general completeness of this article, first published by "Engineering" of London, England.

WORLD'S INTERNATIONAL TRADE.

For the year 1912, the world's international business will reach the enormous total of \$35,000,000,000, according to a report issued recently by the Bureau of Foreign and Domestic Commerce, Washington, D.C. The estimate is made on official returns of exports and imports from virtually every commercial country in the world. Nearly every nation

HYDRO-ELECTRIC CO. NEW RATE SCHEDULE.

THE following is the new rate schedule in force to municipalities using power from the Niagara system of the Hydro-Electric Power Commission:

Municipalities.	Old rate.	New rate.
Toronto	\$18.50	\$15.00
London	28.00	24.00
Guelph	25.00	22.00
Stratford	32.00	30.00
Seaforth	41.00	40.00
Mitchell	38.00	37.00
St. Thomas	32.00	29.00
Woodstock	26.00	23.00
Ingersoll	28.00	25.50
Beachville	38.89	31.00
Tillsonburg	32.00	32.00
Norwich	30.00	32.00
Berlin	25.00	22.50
Waterloo	26.00	23.50
New Hamburg	32.00	32.00
Baden	37.00	37.00
Preston	25.00	21.50
Galt	25.00	22.00
Hespeler	26.00	23.00
St. Mary's	38.00	29.50
Dundas	17.33	16.00
Hamilton	17.90	16.00
Waterdown	37.50	26.60
Port Credit	36.70	31.00
Weston	30.00	30.00
Brampton	29.00	25.00
Mimico	30.74	30.00

The Main Belting Co. of Canada, Ltd., are moving from their present quarters at 25 Common Street, Montreal, to 10 St. Peter Street. The new warehouse has four stories in which a full line of all stock sizes of Leviathan belting up to 38 inches will be kept. On account of the large increase of business, a move to larger and more commodious quarters was found necessary.

John Carr, Pattern Maker, Hamilton, recently added a metal pattern department to his shop, and further extensions are planned for the near future. Mr Carr reports a large order from the Dominion Wheel & Foundries Co., Toronto.

INDUSTRIAL DEVELOPMENT

THE BROWN BOGGS CO., LTD., HAMILTON, ONT.

AMONG the many firms whom an increasing volume of business has compelled to extend their premises must be included the Brown, Boggs Co., who have of late greatly widened their field of operation. Always known as leading manufacturers of sheet metal working machinery of the highest class, they have lately gone in for heavier lines, such as heavy power presses and shears for similar work. They have also extended their line of canning machinery and are now employing a staff of draftsmen on plans for the complete outfitting of the most modern canning plants, including the architectural work, power plant, mechanical equipment, etc.

The Brown, Boggs Co., Ltd., are also manufacturing under patent rights a large amount of special canning machinery, hitherto only procurable in the United States. They are also sole Canadian agents for some fourteen United States manufacturers of canning machinery and supplies.

The present works at the corner of King William St. and Victoria Avenue are now entirely inadequate to the company's growing needs, and a thoroughly modern factory is under erection. This is situated on a fine site of 8 acres, on the west side of Sherman Ave., immediately north of G.T.R. tracks, to which it has a frontage of 935 feet. The site is also served by the C.P.R. and the T.H. & B. R.

The first unit, now rapidly approaching completion, consists of a pattern shop and storage, and a modern foundry. The pattern shop is an up-to-date 3-storey building with a reinforced concrete frame filled in with brick curtain walls. The ground and second floors will be used for pattern storage purposes, patternmakers being accommodated on the top floor. Large window areas, fitted with steel sashes, provide ample natural light, and a very complete equipment of band saws, jointers and other necessary wood-working machinery will be installed.

The foundry is a steel frame building of thoroughly up-to-date design and will

have electric traveling cranes, air-operated moulding machines, sand blast apparatus and other modern appliances. This foundry will give the company about four times their present output.

Later, it is proposed to enlarge the new plant by the addition of a machine shop, blacksmith shop, warehouse, offices and power house; and when these are completed the company's present works, covering an area of about 1½ acres, will be disposed of.

FORD-SMITH MACHINE CO., HAMILTON, ONT.

PROMINENT among the smaller firms of machine builders are the Ford-Smith Machine Co., Hamilton, Ont., who are earning an excellent name for the work they turn out. Their grinders in particular are meeting with much favor, and the firm are now making as broad a line of floor and water tool grinders as any of the concerns in the United States.

The Ford-Smith Co. have, of late, paid a great deal of attention to the standardising of steel safety collars for abrasive wheels, and have finally adopted a standard which they believe meets every requirement. The firm is at present engaged in standardising a line of protective guards and dust exhausts for grinding wheels.



BOILER SHOP OF THE GOLDIE & McCULLOCH CO., LTD., GALT, ONT.

Since moving into their new factory at the corner of Princess and Earl Sts., Hamilton, at the end of 1911, the output of the firm has nearly doubled; in

fact the new premises are already inadequate and considerable extensions are planned for 1913.

THE GOLDIE & McCULLOCH CO., LTD.

GOLDIE & McCULLOCH Co., Galt, Ont., report a good year's business for 1912. During the summer they made a large addition to their boiler shop which is situated in the north quarter of the city, about a mile from the main works. The original shop covered an area of 320 by 120 feet, and the new addition measures 160 by 120 feet, or an increase of 50 per cent. The company have now one of the finest and best equipped boiler shops in Canada, and one which should meet all requirements for some time to come.

The building has a steel frame and brick walls, and consists of a centre 60-ft. bay and two side bays of 36 feet. Large window areas are provided and the monitor over the centre bay has a skylight extending its full length. The floor is of wood blocks laid on edge, and the roof is of 2-inch matched boarding covered with an approved roofing material. The centre bay was originally served by a 25-ton electric traveler by the Morgan Engineering Co., Alliance, Ohio., and

when the shop was enlarged, a 5-ton traveler of the same make was added. The stationary hydraulic riveter exerts a pressure of 150 tons, has a gap of 10

ft. 6 in., and is served by a 15-ton tower crane. Further hydraulic equipment includes a 750-ton flanging press. This is served by a 10 ft. x 12 ft. Rockwell oil fired flanging furnace, and there are two other plate furnaces, also oil fired. Among other equipment installed this year is a very fine 4-spindle flue sheet drill.

A feature of the shop is the excellent artificial lighting. This is by means of flaming arc lights, so placed as to practically eliminate all shadow. We have seldom seen a better lighted boiler shop. An exterior view of the building appears on the previous page.



NATIONAL STEEL CAR CO., LTD.

THE plant of the National Steel Car Co. at Hamilton, Ont., is rapidly nearing completion, and will soon be in a position to turn out thirty steel freight cars each working day.

struction Co., Pottstown, Pa., and the buildings are of that company's standard monitor type of construction. For a height of eight feet above ground level the walls are of National Fireproofing Co.'s hollow tile construction, and above this they are fitted with Lupton continuous steel sash.

The main building is 560 feet long by 200 feet wide and is divided into two bays of 75 feet and one of 50 feet. The 50-foot bay is divided up into forge shop, machine shop, truck shop, tool room and pipe shop. These departments stand next to one another in the order named, the forge shop being at the north end next to the stock yard. Hence, it will be seen that material passes continuously along from one department to another without change of direction. This bay is served by a five-ton Whiting crane. The centre bay (75 feet) is served by two ten-ton Whiting cranes, and is divided up into punch shop (75

being rapidly installed and is of the most modern description in every particular. All machines have individual motor drives and, wherever possible, are fitted with safety guards. In the planing mill, dust and shavings are carried away to the boiler house by exhaust blowers. Heating is by the indirect system, this installation having been put in by Sheldons, Ltd., Galt, Ont.

The paint shop is 300 feet south of the main shop and can easily accommodate thirty cars. It measures 250 by 144 feet and has ten tracks served from the main shop by a transfer table.

All the buildings are fitted with an efficient sprinkler system, in addition to which there is a 1,000-gallon steam driven Underwriters' fire pump in the power house. Steam for this and for the steam hammers, air compressor, heating, etc., is supplied by three 280 h.p. Erie City water tube boilers built by the John Inglis Co., Toronto. Compressed air is



NATIONAL STEEL CAR CO. NEW PLANT. MAIN SHOP DURING COURSE OF ERECTION.



NATIONAL STEEL CAR CO. NEW PLANT. PAINT SHOP UNDER CONSTRUCTION.

The company was incorporated in July, 1912, under a Dominion charter and has its head offices in the Transportation Building, Montreal. The authorized capital stock is \$6,000,000, divided in \$3,000,000 of 7 per cent. cumulative preference stock and the same amount of common stock. The paid-up capital is \$3,500,000.

The works are situated on a site of fifty-five acres at the east end of the city on the shores of the bay, and it is the company's intention at some future date to build a dock and dredge the bay to enable them to handle raw stock by boat as well as by rail. The plant has been under construction since the latter part of July, 1912, and is expected to be in full operation by the end of January. Up to the present, four buildings and a stockyard runway have been erected. The last named extends east and west for a distance of 520 feet and is served by a ten-ton electric crane. The four buildings comprise power house, offices, main shop and paint shop. All steel work is by the McClintock-Marshall Con-

x 200 feet), construction department (75 x 80 feet) and steel car erecting shop (75 x 280 feet). The other 75-foot bay is on the west side of the shop and forms the planing mill and wood car erecting shop. The equipment is now

delivered by a Canadian Ingersoll-Rand steam driven cross-compound Corliss two-stage air compressor of large capacity. The value of the buildings and equipment is about \$700,000, and the plant is insured for \$1,000,000, this cov-



INTERIOR OF MAIN SHOP, NATIONAL STEEL CAR CO. NEW PLANT.

ering raw material and work under construction in addition to the buildings, machinery, etc.

Before the plant was completed, an order for 1,500 box cars was received and others have since been obtained. Work is going busily ahead and the first car built on the plant has just been turned out.

Officials of the Company.

The executive officers of the company are:—

President—Sir John Gibson, Toronto.
Vice-President and General Manager—Basil Magor, Hamilton.

Secretary-Treasurer—Mostyn Lewis, Montreal.

Purchasing Agent and Assistant Treasurer—A. Butze, Hamilton.

Accountant—L. A. Rodger, Hamilton.

The following is a list of the directors:—

Sir John Gibson, Toronto.

Basil Magor, Hamilton.

W. G. Ross, Montreal.

Wm. Southam, Hamilton.

J. J. Scott, Hamilton.

W. K. Brice, New York.

Wm. Barelay Parsons, New York.

Sir Henry Pellatt, Toronto.

Mortimer B. Davis, Montreal.

SELBY & YOULDEN, KINGSTON FOUNDRY.

IN reviewing Kingston's industries, one that merits more than passing notice is the business of Selby & Youlden, Ltd., or the Kingston Foundry. Walking on Ontario Street, south, past the works of the Canadian Locomotive Company and the entrance to the dock and yards of the Kingston Shipbuilding Company, one faces, at the foot of Union Street, the buildings and plant of the Kingston foundry.

The establishment of the concern dates back three-quarters of a century. In 1895 it was rented to Raney, Reid & Selby. After four years of business, the first mentioned partners dropped out, William Reid in 1897, and F. Raney in 1899. Charles Selby, Gore Street, the president of the present concern, continued for a year alone, until, in 1900, he, in conjunction with the late Henry Youlden purchased the property. Three years later it was incorporated. Since the death of Mr. Youlden, Mr. Selby has undertaken the management. Mr. Angus Orr is vice-president, and Mr. M. F. Thompson, secretary-treasurer.

The buildings—machine, boiler, blacksmith and moulding shops, cover a space of 180 feet by 220 feet. The firm has a private wharf 200 feet long, and at this and on the marine ways, 110 feet long, a great deal of repair work is carried on

by expert mechanics. The latest machinery has been installed in the work shops, with tools and appliances.

At the present time ninety men are employed in the manufacture of marine and stationary engines and boilers, steam capstans, double and single drum hoisting engines, gasoline engines, etc. A specialty for which the firm is well known, and of which they are the sole agents, is the "Carrol" Propeller wheel.



NEW FOUNDRY OF SHELDON'S, LTD., GALT, ONT.

AMONG other firms whom an increasing volume of business compelled to enlarge their manufacturing facilities during 1912 must be mentioned Messrs. Sheldon's, Ltd., Galt., who have recently built a large extension to their machine and sheet metal working shops, and are now rapidly completing a new foundry of thoroughly up-to-date design and construction.



NEW FOUNDRY OF SHELDONS, LTD.—UNDER CONSTRUCTION.

This new foundry is situated on the north side of the company's property and lies parallel to the old foundry and main bay of the machine shop. The building is steel framed, with curtain walls of hollow tile set in cement mortar. The tile work is coated over with a layer of cement plaster both inside and outside the building. Large window areas are provided in the side and end walls, equipped with Fenestra steel sash, as is also the 40-ft. monitor. The roof is of 2-in. matched boarding covered with Barrett specification roofing.

The foundry is divided into the usual three bays, the centre one being 40 ft. wide and the two wing bays 35 ft. each. The two latter have a height of 17 ft. to the truss chords, while the head room in the main bay is 34 ft. A 15-ton Northern crane of the 3-motor type serves the latter bay, and a second crane

of similar capacity may be added when it becomes necessary to extend the foundry, the shop columns and runway having been designed strong enough to carry a 30-ton load. The columns are spaced at 16-ft. centres, thus, so to speak, dividing up the side bays in twelve floors. The north bay will be used for light moulding and machine work. The roof trusses over this bay are made specially strong, it being the intention eventually to install over each floor a 5-ton electric crane of approximately 16-ft. span. The four most westerly floors are now being equipped with these cranes, which are operated from the floor and will serve four heavy moulding machines.

In the south bay are the cleaning room, cupola room and core department, the extreme east end of this bay being occupied by the heating apparatus. The latter is of the Sheldon type, and distributes the heated air by two underground concrete ducts running up each side bay near the crane columns. An

outlet at the foot of each column delivers warm air at floor level. Above the heating apparatus, there is a reinforced concrete platform resting on structural steel columns. This carries the lavatories and is reached by a steel stairway. Two cupolas will be installed of 34 in. and 46 in. diameter. The cleaning department will be fully equipped with up-to-date grinders, tumbling mills, etc., and a sand blast apparatus will be installed in an annex at a later date.

The main moulding floor has a 32 ft. by 20 ft. pit of concrete construction, fitted with eyebolts and stayrods for holding down large copes. The 15-ton Northern crane serving this floor has been built to a special specification. It has steel-tired wheels and an Electric Controller & Mfg. Co.'s dinkey dynamic braking controller on the hoisting mechanism. Provision has been made for the

addition of a 5-ton auxiliary hoist when desired. Power will be supplied for all the cranes by a 50 k.w. motor-generator set delivering current to a three-wire system at 220-110 volts. The cranes and are lights operate on 220-volts, while the tungsten lamps and some of the motors in the machine shop take 110 volts.

Artificial lighting in the foundry is by Adams-Bagnall flaming arc lamps in the main bay, while the side bays are lighted by 250-watt low voltage tungstens. When finally completed this foundry will have a maximum output of 200 tons per week and will give employment to about 60 men.

With a view to taking care of this increased output, the company have lengthened their machine shop by 150 ft. and have under consideration the addition of another 75 ft. next spring. They will also probably erect a 4 or 5-storey brick building to form a stores department.

A CREOSOTING PLANT FOR TIES.

WITH contracts to treat from 500,000 to 1,000,000 ties annually for ten years for the Canadian Pacific Railway Co., as well as a contract with the Canadian Northern Railway, a creosoting plant has recently been erected at Trancona, six miles east of Winnipeg, by the Dominion Tar and Chemical Co., Ltd. The plant at present has a capacity of over a million ties a year, but is already being enlarged. It occupies an area of 40 acres. There are four long yard tracks for the storage pipes, with accommodation for 700,000 ties.

The buildings are of steel frame, covered with corrugated iron. Three cylinders are in operation, and a fourth has been ordered. The cylinder doors are swung from a crane attached to the cylinder itself. They receive oil from these tanks, 20 ft. in diameter and 14 ft. high, holding 34,500 gallons.

Three oil-pressure pumps, two vacuum pumps and an air compressor are used in the operation. The ties first have the bark removed, and are then seasoned before treatment. The C.P.R. and C.N.R. contracts specify the Bethell process, and the injection of a minimum of two U.S. gallons per tie. When the timber is not air-seasoned, the ties are steamed, followed by a vacuum. The cylinder is then filled with creosote and the desired amount injected. The oil is next ejected and the ties allowed to stand a while.

A five-ton locomotive crane is used for handling the treated ties. Steam for the plant comes from two 450 horsepower Babcock and Wilcox boilers. Electricity is generated from a 350 amp. 100 volt dynamo driven by a 50 h.p. engine. There is a machine shop near the

boilers. Over 135 workmen are employed on the plant, which is directed by Mr. F. W. Coates, manager, and Mr. G. G. Roberts, assistant manager.

The ties treated are principally jack pine, Norway pine, tamarack, and white spruce. Trials are also being made with British Columbia spruce and fir, and black spruce and poplar from Ontario. Most of the oil used comes from the distilling plants operated by the Dominion Tar and Chemical Co., at Sault Ste Marie, Ont., and Sydney, N.S. The head office of the company is in the Birks Building, Montreal. Mr. E. Bernard Smith is the general manager.



EMPIRE MFG. CO.'S NEW SMELTING PLANT.

DURING the past year the Empire Mfg. Co., Ltd., London, Ont., the well-known brass founders and makers of plumbers' fittings, have added to their

The furnace has a capacity of 3,500 lbs., and three heats per day are run. Before going to the smelter the turnings of course pass through an electro-magnetic separator, which removes all steel and iron chips. The ground floor of the building also contains a very fully equipped laboratory, where analytical tests of raw and finished material are regularly carried out.

The basement forms a metal storage room, and washing and grinding are also done here, the equipment including an inclined rotary wet cinder mill. Here, too, is located a motor driven positive type blower for the Rockwell smelting furnace.

The company's brass foundry is well worth a visit as it is laid out in a thoroughly modern way with a view to economically turning out high-grade castings in large numbers. The machine moulding equipment includes a Berkshire automatic moulding machine for 19 x 13



EMPIRE MFG. CO. NEW 3,500 LB. OIL-FIRED BRASS SMELTING FURNACE

plant a new one storey and basement building measuring 150 ft. by 50 ft. It is of reinforced concrete and forms a smelting room, metal stores and laboratory. In the smelting room there has been installed a Rockwell No. 43 reverberatory oil-fired furnace for clarifying reclaiming and refining all metals used by the company for factory purposes. The furnace delivers to the foundry No. 1 quality ingots, thus rendering the works independent of supply. An industrial track runs across the floor alongside the furnace and trucks carrying the ingot molds pass along this, the molds being poured direct from the furnace without the intervention of a ladle.

in. flasks. This is operated by four men and has a capacity of 600 moulds per day. There are also two Tabor pneumatic moulding machines, each having a capacity of 150 moulds per day; each machine is operated by one man. Eight men are kept busy on hand moulding and there are also sixteen core makers. The brass is melted in three Rockwell double-chamber rotary oil furnaces of 1,500 lbs. capacity each. Three to five heats per day are taken off. These furnaces have a hood over them by means of which the waste heat is drawn off by suction fans and used for drying cores.

The company's machine shop is very completely equipped for rapid and accurate production and the plant, as a whole, forms one of London's most important industries.

DOMINION WHEEL AND FOUNDRIES, LTD., TORONTO.

DOMINION Wheel and Foundries, Ltd., is a concern that has just been incorporated with a capital of \$250,000 for the purpose of manufacturing chilled iron car wheels, brake shoes and other railway castings. The company has secured a site of 4 acres in Toronto at the corner of Eastern Avenue and Cherry Street. Here, the building for the wheel foundry is rapidly nearing completion, and it is altogether likely that before the end of this month, the foundry will be in active operation and turning out 300 wheels per day. The contract for the steel work for the building was let to the Canada Foundry Company who bound themselves to fabricate and erect same in the short space of six weeks from the date of signing the contract.

Mr. J. A. Kilpatrick, who recently resigned his position as General Manager of the Canada Iron Corporation, Montreal, is President and General Manager of the new company, which intends, in the spring to erect further buildings and to take up the manufacture of brake shoes, journal brasses and general railway castings.

Mr. Kilpatrick is also president of the Albany Car Wheel Co., Albany, N.Y., and of the Copp Stove Co., Fort William, Ont.

THE STEEL COMPANY OF CANADA, LTD.

THIS corporation report that their total production for 1912 broke all previous records, and present prospects point to an even larger output during 1913.

Work on the new blooming and rod mill at Hamilton has been pushed ahead as rapidly as possible. The buildings are now completed and as the equipment will be installed this month the mill is expected to be in full operation by the middle of February. This is the most important extension that has been made to any of the plants since the amalgamation of the various concerns comprising the Steel Co. of Canada took place, the total cost being about \$1,500,000. The mill is intended to supply billets for all merchant shapes and wire rod for bolts, etc., to the company's various branches which have hitherto been purchasing this semi-finished material from outside sources.

The open hearth plant at Hamilton is being remodelled to suit the requirements of the new mill. Two new furnaces have recently been added, making six in all. A 130-ton mixer has also been installed. Hitherto 6-in. ingots only have been turned out, these being bottom poured in pits. In future, 16-in. top-poured ingots will be produced. For this purpose, the floor pits will be filled in and standard gauge track laid down, allowing ingot cars to enter at one end of the building and, after the ingots are poured, to pass on immediately to the soaking pits in the new blooming mill. The new blooming and billet mill is housed in a building measuring 480 ft. by 60 ft., while the rod and merchant mill is 560 ft. by 80 ft. Both are steel frame buildings with steel sash, the sides being closed in with corrugated sheeting. They were erected by the Hamilton Bridge Works Co.

Equipment Data.

The equipment, which is of the very latest type, is being installed by the Morgan Construction Co., Worcester, Mass., and includes the following:

Two 4-hole gas fired pit furnaces, equipped with Morgan gas producers, having George automatic feeders and Dyblie valves for controlling the gas reversals.

One 34-in. two-high reversing blooming mill, complete with reversing tables.

One 10-in. by 10-in. vertical hot bloom shear, with its tables.

An 18-in Morgan four-train continuous billet mill provided with Edwards flying shears.

One combination rod and bar mill, together with gas-fired Morgan continuous heating furnace, roll trains, Edwards flying shears, cooling bed, bar shears, etc.

The entire equipment will be capable of operating as a unit to a considerable degree—the blooming mill supplying blooms to the billet mill, and the billet mill supplying billets to the rod and bar mills, and will enable the Steel Co. of Canada to produce the various products for which the mills were designed, at a minimum of cost. All of the equipment is to be electrically operated. The blooming mill, with its accessory equipment, is being supplied by the United Engineering & Foundry Co., Pittsburgh, Pa.

Further equipment includes the following cranes:

One stripping crane over the soaking pits.

One charging crane for the reheating furnaces.

One 20-ton overhead traveller.

One 5-ton and one 15-ton yard traveller.

It will be seen from the above that the company will soon have at their

disposal a thoroughly modern and well-equipped mill.

THE WATEROUS ENGINE WORKS CO., LTD., BRANTFORD, ONT.

THIS old-established firm of engineers have been very busy during 1912. During the first half of the year, work was rushed forward on the new foundry, an illustrated description of which appeared in last month's issue of Canadian Machinery. For the benefit of new readers, however, there is here given a condensed account of this foundry, which went into operation last July.

The new building is on the north side of the plant, and runs parallel with the machine shop. It measures 240 feet long by 110 feet wide, with an extension measuring 68 feet by 30 feet for the core ovens. There is also a gallery which accommodates the sand and coke storage bins, brass foundry, etc.

The moulding, core-making departments and core ovens are all under one roof. The main bay is used for floor moulding and for heavy castings. This bay is served by a 15-ton electric travelling crane, which, by means of a 120-ft. extension, operates outside the building. In addition to this crane, the main floor is served by jib cranes, which are not fixed in one position, but can be transferred from one column to another.

The south 30-ft. bay is used for smaller floor work. It is served by a 5-ton crane, with a span of 26 ft. 6 in. The north 30 ft. bay accommodates the core-makers, bench moulders, cupola room, etc. For 64 ft., it is used for small floor work. The core room has a concrete floor served by a 5-ton electric traveler. There are five core ovens, four of which are 20 ft. long, the other being 12 x 10 ft., and having a revolving shelf for drying small cores.

The gallery extends the full length of the north bay and is 20 feet above main floor level. The coke and sand are elevated to a receiver above the gallery, which has two chutes, one to a large coke storage bin near the cupolas, and the other to a 12-inch rubber belt conveyor which carries the sand to a series of storage bins. The gallery floor is fitted with chutes to the main floor, over which the sand truck passes.

The cupola room measures 32 ft. x 30 ft. It contains two cupolas. The brass foundry occupies a space measuring 32x30 ft., at the east end of the gallery. There are two pit furnaces, and a Kroeschell-Schwarz gyrating flame tilting furnace of 500 lbs. capacity. For fuel, natural gas is used.

These new extensions practically double the foundry output of the Waterous company, which necessarily increases the output of the other departments.

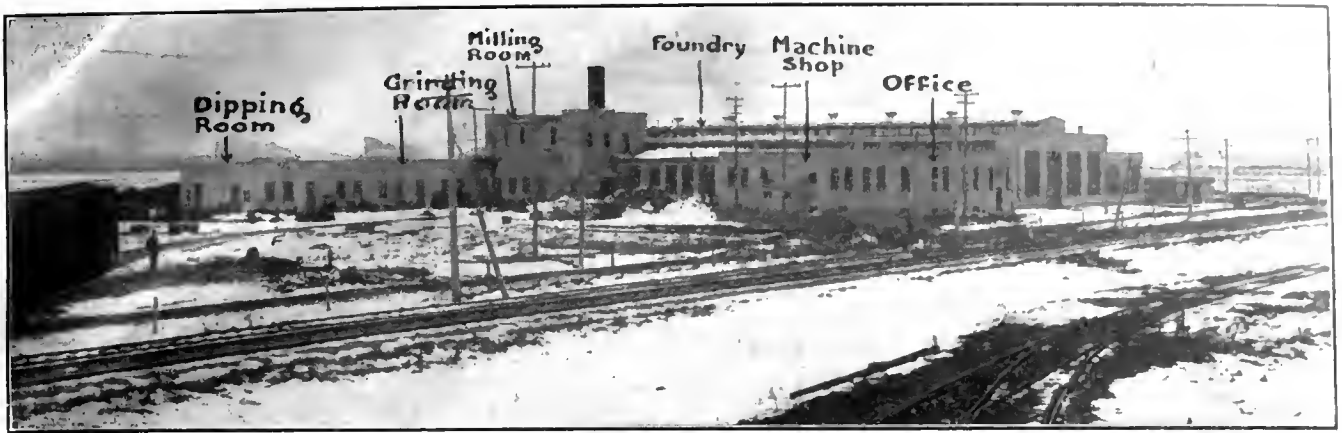

PLANT OF THE ANTHES FOUNDRY CO., WINNIPEG, MAN.

THE ANTHES WINNIPEG FOUNDRY

IN THE Western part of Winnipeg, along Saskatchewan Avenue, two miles or more from the corner of Portage and Main, so many Toronto concerns are building branches and warehouses that the district is given quite an Eastern appearance. Here, between Notre Dame and Portage Avenues, the Anthes Foundry Co. have built a large foundry, larger than the parent building in Toronto. Across the road is the Dominion Bridge Co. plant, and nearby is the new plant of the Canadian Fairbanks-Morse Co., under construction. Excavations have also been begun for the Western branch of the Pease Foundry Co., of Toronto, and within a block is the warehouse of the Canadian Consolidated Rubber Co., of Montreal. In the vicinity, too, the Dominion Radiator Co. will erect a warehouse.

Climatic Conditions Considered.

The Anthes foundry has just been completed. Situated on a five-acre lot it is of brick and steel construction throughout, and of the firm's own special design. The work was carried out under the direction of Mr. E. J. Lennox, architect, of Toronto. The main object of the firm was to give plenty of light, and to erect a building that would best off-set the weather conditions of Manitoba, principally the extreme cold. Whereas, lots of processes might be carried on in Toronto in an open building, in Winnipeg, the latter must be closed and heated during the winter months.

The building has been laid out to give every advantage for a continuous process of production. From the foundry, there follow in order the cleaning and milling room, the inspection room, the oiling room and the yards, where the finished product is stored. The foundry capacity can be doubled without any change being made in the building.

Foundry Lay-Out.

The foundry proper has twenty pipe floors, and thirty fitting floors, giving an output of about 40 tons. The lay-out is such, that, at any time desired, a continuous floor system can be installed without material alteration in the construction of the moulding shop. A feature of this shop is the large proportion of wall area devoted to windows for natural lighting. Artificial illumination is supplied by lantern lights on the roof.

The plant is laid out so that raw material can be taken in from either side direct to the charging floor. Molten metal is carried from the furnace by an overhead I-beam track system, and the finished castings are removed by the same method. An industrial tramway as an auxiliary to the overhead system is being laid.

Castings, as they are taken from the sand are loaded on surface cars, and run direct to the milling rooms, where they are cleaned by being put through a battery of tumbling mills. This completed, they are placed on cars and taken into the grinding and inspection room, immediately adjacent. Here, all the rough edges are ground from the castings, and each piece carefully inspected for sand holes or other defects, each man's work being kept separate. After an inventory has been made of the inspected goods, they are placed on the car again, and conveyed to the oil or dipping room, where they are given a coating of boiled linseed oil, thinned out with benzine and conveyed direct to the shipping warehouse.

The cupola is a 75-inch Collian, manufactured by Byram & Co., of Detroit. Blast is supplied by a No. 7 Piqua positive blower, driven by a 60 horsepower Crocker-Wheeler three-phase alternating current motor. Owing to extreme cold over night during the winter, it has been found necessary to put a metal damper in the cupola immediately after the bot-

tom is dropped, so that no heat can escape from the foundry.

Grade Their Own Sand.

Because the foundry business in Winnipeg is still in a more or less pioneer stage, foundrymen find it difficult to get a good grade of moulding sand unless imported from a great distance at a high cost. The result is, that those engaged in the iron trade are forced to put in sand grinding and mixing machines, thus practically making their own moulding sand. This has worked out well in the Anthes Foundry, and results are so good that the majority of foundries, irrespective of location, may find it advantageous to grade their own sand.

The machine shop, which is about 40 ft. square, is used for general repairs to equipment and for patternmaking. Provision has been made to extend the machine shop as necessary in the future. The whole plant is operated by hydro-electric power, supplied by the city of Winnipeg, which, it is claimed, is the cheapest power on the American continent. The patterns are kept in fire proof vaults under the office building.

General.

The superintendent's office is the eye of the works, being connected with the machine shop, the foundry, and the yard. The business office is divided into one general office, and two private offices. The woodwork is of stained British Columbia fir, beautifully finished. At present, the foundry buildings are heated by large furnaces placed at intervals along the floors, but this is only temporary. A forced draft system will be installed during the coming summer.

The foundry is situated in the heart of a railway district. About 100 yards distant, the C.N.R. Hope Point branch runs parallel with the west side of the foundry, and parallel with the north side is the Souris branch of the C.P.R. Nearby, are also the Pembina branch of

the C.P.R. and the Midland Railway of Manitoba, which is owned by the G.N.R. The latter had intended putting their terminals at this point, but changed their plans, and will now lease all their ground for warehouses. There is also a private spur into the plant.

Trouble With Labor.

The greatest drawback with a foundry in this district is the general scarcity of labor in the summer and fall, on account of the demand on the farms. During October and November, \$2.75 to \$3 is paid for yard labor. Conditions improve as winter approaches.

Another drawback is the great distance over which raw materials have to be brought, necessitating the high freightage on pig iron and coke. Manufacturers may judge for themselves from the present market price of pig iron in Winnipeg, which is \$27 a ton, and \$10.60 a ton for foundry coke.



STANDARD UNDERGROUND CABLE CO., OF CANADA, LTD., HAMILTON, ONT.

IT MAY be of interest to our readers to know something of the history of this newcomer into Canadian industrial life some eight months ago. It is not strictly correct, however, to speak of it as a newcomer because the associate

find the latter to have been a pioneer on this continent in making electric cables for underground service.

The parent company began the manufacture of lead covered cables for transmission of electricity about 1882 in Pittsburgh, Pa. It originated and developed many of the types of cables and manufacturing processes in use to-day and was for years the only manufacturer of such materials in the United States. From the small plant in Pittsburgh the company widened its scope of business and increased its lines of products, until now, in addition to the plant at Pittsburgh, enlarged from time to time, it has a large aggregate of plants at Perth Amboy, N.J., and Oakland, Cal., a total floor space of over 12 acres. The products that come from these various plants include electric wires and cables of all kinds for street railway, light and power, signal, telephone, telegraph, fire alarm, and any other service involving transmission of electric current by underground, aerial or submarine circuits. These products also include cable accessories such as terminals and junction boxes, insulating materials, cable splicing tubes, hangers, etc.

It will be seen that while the company's name carries the implication that it is concerned chiefly with the manufacture of "underground cable" yet, as a matter of fact, its products include al-

The directors have long been aware of the wonderful possibilities of the Canadian field and realized that their company's increasing Canadian business could only be adequately fostered by building a plant in the Dominion that would have every modern facility possessed by the United States plants for turning out high quality products and in sufficient volume to keep pace for many years with the increasing demand resulting from the rapid electrical development of Canada. The choice of locality fell upon Hamilton, Ont., and there the new plant was erected on a tract of land fronting 400 feet on Sherman Avenue and extending 600 feet along the T.H. & B. Railroad, a location which has every advantage, both for manufacturing and shipping.

The buildings erected so far include: One three-storey brick and structural iron building, 64 x 335 feet; one one-storey saw tooth building, 60 x 224 ft.; one one-storey saw tooth building, 60 x 250 feet; one one-storey building, 64 x 90 feet; one one-storey building, 30 x 70 feet; also an office building and other small buildings. They are of the very latest type of factory construction and represent, with their equipment, an investment of \$500,000. The plant is electrically operated throughout by power from the Dominion Power and Transmission Co.'s lines. The electric

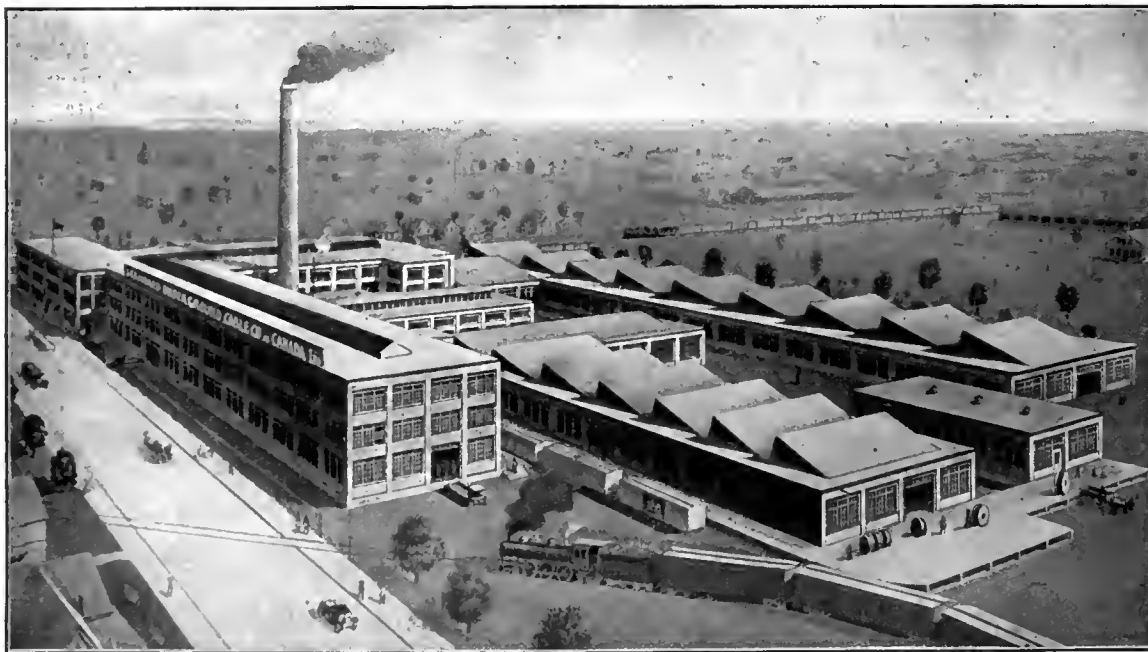

PLANT OF THE STANDARD UNDERGROUND CABLE CO. OF CANADA, LTD., AT HAMILTON, ONT.

American company has been selling to the Canadian trade for many years, its wires, cables and cable accessories being well represented on many important electrical installations in the Dominion. Tracing back the new company's lineage through its associated company, we

most every kind of conductor known to the electrical industry. Indeed, in range of product and in the aggregate value of gross business, this company is said to exceed any exclusively electric wire and cable manufacturer on the American continent and probably in the world.

motors are of three-phase, 220-volt induction type. The three testing laboratories are equipped with the most modern and up-to-date appliances for thoroughly testing all products before shipment. These appliances consist of regulating transformers giving voltages as

high as 60,000 volts, Wheatstone bridges, D'Arsonval galvanometers, Fisher testing sets, etc., for determining insulation resistances, capacity, conductivity, locating grounds, leads, crosses or other faults in cables.

True to their policy of employing, so far as practicable, Canadian skill in the Canadian venture, the company employed, in the main, Canadian contractors to erect the new buildings and the Hamilton Bridge Works Co., Limited supplied the structural iron. The subcontractors and workmen were all Canadian. The architects were Prack and Perrine, factory experts of Pittsburgh and Hamilton.



STANDARD STEEL CONSTRUCTION COMPANY.

THE Standard Steel Construction Co., Ltd., recently purchased thirty-six acres of land between Welland and Port Robinson on the canal and served by the Grand Trunk and Wabash Railways. There is in course of erection a plant which will have an initial capacity of 500 tons of finished material a month, and which will be in operation in February. There is on order a large amount of stock material which will allow of prompt shipments of steel work for buildings, bridges and similar structures. The officers of the company are: E. O. C. Kunnel, president; and R. W. Knight, vice-president. Mr. Kunnel and Mr. Knight were formerly associated with the McClintic-Marshall Construction Co. of Pittsburg.



TO MAKE 100 MOTOR CARS A DAY.

THE Ford Motor Co., of Walkerville, Ont., are doubling the capacity of their factory. They have just completed a new engine house and are now building a gas producer and boiler house, an addition to the Heat Treatment building measuring 37 x 135 feet, and an addition of four storeys to the main factory measuring 507 x 75 feet. All these new buildings are up-to-date, being fireproof, and of steel and concrete construction. The present building measures 200 x 75 feet. The plant lies along the Detroit River. Wells and Gray, of Toronto, are the architects.

The Ford Motor Co. at present are turning out 50 cars per day. The output will, later, be increased to 100 per day, and it is hoped to manufacture 18,000 cars in 1913. The new factory will provide employment for 2,000 men when in full swing, and will then duplicate the work done in the firm's Detroit plant.

Orders for the new equipment have been placed with the A. R. Williams Machinery Co., of Toronto, amounting to

800 machines, worth altogether about \$32,500. These are in the nature of grinders, automatic gear-cutting and gear-shaping machines, special drills, screw machines, lathes, grinders, internal grinders, large presses, heat treating apparatus, bulldozers, compressors, and a large gas producer plant.

In 1909 the production of the Walkerville factory was only 484 cars; the following year 1,265 cars were built. In 1911 the production doubled again, the output being 2,675. The production for 1912 will be 7,000 cars, and in 1913 they hope to turn out 18,000 cars.

Recently, the company purchased fifty acres of land in Sandwich East, near Walkerville, and although no definite decision has been reached as to how this land will be used, Mr. G. M. McGregor, manager of the Walkerville Co., has stated that "If business keeps on growing at the rate it has in the past, we probably will utilize the ground purchased for the erection of large assembling plants. In that case, the present factory would all be used as a machine shop. The new property is ideally located as to shipping facilities, and the shipping probably would all be done from there."



HAMILTON MALLEABLE IRON CO.

THE Hamilton Malleable Iron Co., Hamilton, Ont., have decided to build their plant in the "Ambitious City" after several conferences during the past few weeks between the promoters of the concern and Mr. Marsh, Hamilton Commissioner of Industries. The company has been formed with a capital of \$600,000, drawn from Toronto, Hamilton and Brantford.

Although the site has not been definitely decided on, the company have three locations under option in the east and west ends of the city. J. E. Hammond, formerly with Pratt & Letchworth Co., Ltd., Brantford, for 12 years as manager, will be one of the directors, and assume management of the plant. The output will consist principally of malleable iron castings for railroad, agricultural and miscellaneous work for custom trade. The plant will cost in the neighborhood of one-quarter of a million dollars, and will employ about 500 hands, a large number of whom will be skilled mechanics.

The main foundry building will be 600 feet long and 200 feet wide. This building will be divided into two bays, with high speed electric traveling cranes in each bay. In this building will also be located four melting furnaces with a capacity of 15 tons per heat. There will also be located in this building annealing furnaces sufficient to take care of

the output, as well as the latest cleaning and finishing equipment. In addition to the main building, there will be an office building, also buildings for pattern storage, pattern shop, machine shop, core shop, carpenter shop and storehouse. Parallel to the main building there will be an outside crane runway, by which all the raw material for the plant will be unloaded and stored.

All the buildings will be fire-proof and of modern construction throughout. The windows will be of metal and glass. Waste heat boilers, molding machines operated by compressed air, the latest type of sand blast installation, exhaust tumbling barrels, will be included in the equipment.

The plant will be connected with the railways and have individual tracks leading to and serving the various buildings. The plans for the buildings are being prepared by Prack & Perrine, 36 James Street south, who will also have charge of the construction and installation of equipment.

The plant is being designed in units, which will allow it to be enlarged to double capacity. A very strong bid was made for this concern by other cities and towns, and Hamilton is very fortunate in securing it. A great many of the factories located here use large quantities of malleable iron castings, such as the National Steel Car Co., and the Sawyer-Massey Co. In deciding to go to Hamilton, the company took into consideration the advantages possessed by Hamilton of favorable freight rates on both raw and finished materials, and also on account of a blast furnace and steel plant being located in this city.

The plant will be in operation by July 1, 1913, and the temporary office of the company is in the Sun Life Building.



CROCKER-WHEELER PLANT.

THE announcement is made that the Canadian Crocker-Wheeler Co. Ltd., will complete their new building in the early part of March. This concern is among the biggest manufacturers of electrical machinery on the continent. It has established extensive works and head office at St. Catharines, maintains Canadian branch offices at Montreal, Toronto and Vancouver, and also has an American head office and works at Amperre, N.J.

The plant comprises a splendid group of buildings, the main building extending 300 ft. in length with an L extension of 100 feet.

The new building now under way will be 290 x 75 feet in area, and two storeys high, built of brick, and of mill construction design. The equipment of machinery to be installed will cost over

\$100,000. and will bring the total investment up to \$350,000. The company has recently added a new corrugating 12 ft. press, which will cut all the metal transformer tanks and will add 25 per cent. to the speed efficiency of the equipment. The various departments of the plant are the machine shop, pattern shop, punch department, erecting shop, testing, insulation, assembly and stock rooms with upper floor galleries extending along both sides of the building used as the winding department.

The machine shop is 300 ft. long and a cement floor is laid throughout. All machinery is driven by individual motors, there being lathes, drills, presses, planers, pneumatic grinders, boring machines, etc., and a 30-ton traveling crane. The pattern shop has its own outfit of lathes, planers and saws.

The standard line of Crocker-Wheeler apparatus includes all types of motors, generators of engine coupled, belted and turbo types, motor-generator sets in all types, a complete line of transformers, single, three phase, artificial and self cooled. The core type transformer

The mechanical force now numbers 170, and the office staff 30, making a total of 200, and with the completion of the new building, a still larger force will be required.



THE CANADIAN HANSON & VAN WINKLE CO., LTD.

THIS well-known company have, during 1912, erected a \$100,000 modern factory on Morrow Avenue, Toronto, and will occupy same by the middle of the present month. A line of goods similar to those produced by the American company will be manufactured. The factory has a 200-ft. siding on the C.P.R., and is of heavy mill construction throughout. The main building measures 110 ft. by 50 ft. and has four storeys. The various departments include a nickel foundry for the supply of nickel anodes, a brass foundry for the supply of brass and copper castings, a facing mill for the production of foundry facings and supplies, a buff and wheel department and an electrical shop

employed by the company can be clearly and thoroughly demonstrated to prospective customers. This is very completely equipped and includes steam jacketed kettles containing solutions of cleaning compounds. Next to these is a steel welded seamless tank containing a Kostico cleaning solution, used instead of the ordinary potash solutions, so commonly employed. This tank is fitted with upright rods, operated from main line driving shaft by eams, thus allowing the dip baskets attached to the end of the rods to be given a constant vertical, agitated movement in the tank, which aids very materially in hastening the cleaning of the work, and also adds to the thoroughness of same. There are also several mechanical plating barrels which will be shown in actual use.

The cost of plating articles, which in the absence of mechanical plating apparatus must be strung or plated in trays, has led to the introduction of various kinds of plating barrels more or less efficient. The cheapening in the cost of plating by the use of such apparatus has



GENERAL VIEW OF THE ELECTRO-PLATING DEMONSTRATION PLANT, CANADIAN HANSON & VAN WINKLE CO., LTD.

which is perfectly efficient and reliable, has been adopted by the company as its standard design. It is their aim to produce a transformer of the highest efficiency constructed on the simplest and most rugged plan enabling it to withstand severe and continuous service for an indefinite period.

for making Hanson & Van Winkle plating dynamos. There are also departments devoted to the manufacture of polishing and grinding machinery, brushes, etc.

A feature of the factory is a complete electro-plating plant where the apparatus constructed and the methods em-

been so apparent that everything introduced to the market has been tried, but in the majority of instances due to some mechanical or electrical defect, the plating barrel has been abandoned. In the apparatus manufactured by this company both the electrical and mechanical features have received close attention

and have been much simplified. The barrel is entirely submerged, thus permitting a much larger quantity of work in each batch. The drive is from the outside, thus avoiding the use of belts running in the solution. Two speeds are provided. The barrel is removeable at any time, without throwing off the belt or interfering with the drive. The whole apparatus is strongly built and

NEW BRASS FOUNDRY AT SARNIA.

IN order to cater to the demands of eastern and western Canada for water, plumbing and gas brass goods, the H. Mueller Manufacturing Co., Ltd., of Decatur, Ill., are erecting a large factory at Sarnia, Ont. They are, at present, completing only three sections of a large plant which they expect ultimately to erect, one of which is now finished.

B. Mueller, Robert Mueller, Adolph Mueller, O. B. Mueller, Carl G. Heiby, and Fred L. Riggins.

Among the men who will operate the new plant, including O. B. Mueller, is Carl G. Heiby, at present foreman of the tool-making department, at Decatur, who goes to the new plant as vice-president and superintendent. Fred L. Riggins becomes secretary of the new com-

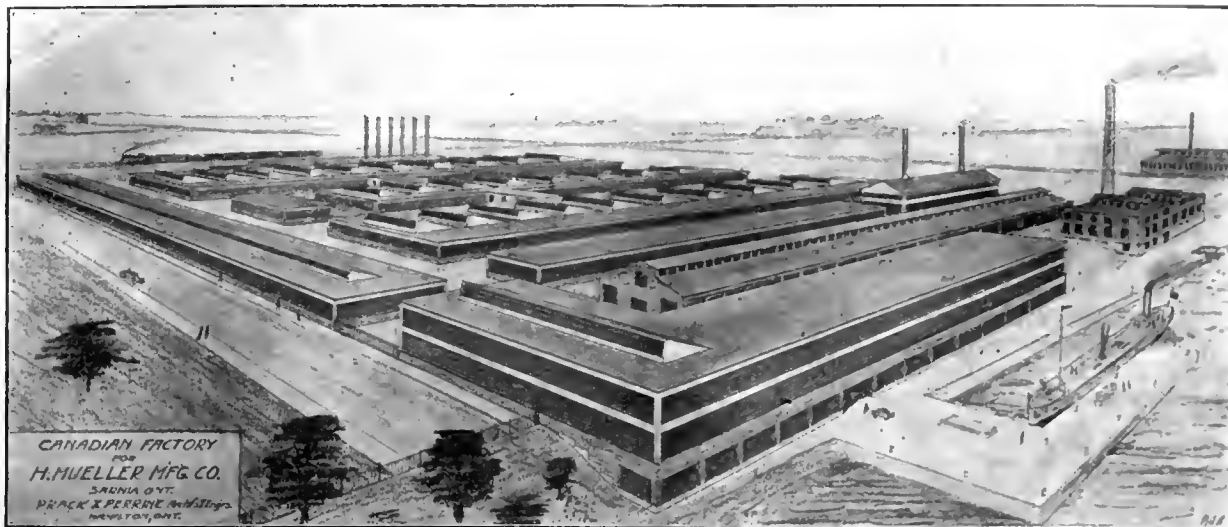

consists of an outer wooden tank for containing the solution, a perforated revolving plating barrel, made of wood or celluloid, in which to hold and tumble the work while deposition is going on, all necessary rods and connections, and a special patent countershaft.

The new factory is heated on the Webster vacuum system from a central heating plant, and is operated by city hydroelectric power.

THE WILT TWIST DRILL CO.

THE Wilt Twist Drill Co., of Walkerville, have placed equipment orders for their new factory, in which they intend to make machines of their own patented designs. The best and most modern equipment will be installed. Many influential stockholders are behind the new company, including Walkers, of Walkerville, and prominent men of Detroit. Mr. Wilt has had wide connection with the automobile trade, and was known as a successful manufacturer in Detroit.

The company has a capital stock of \$150,000, and the incorporators are: Hobart Anderson Springle, Sidney Cecil Robinson, Walter Chater, Edgar Francis Ladore and Hiram Holcomb Walker, all of Walkerville. The company will manufacture and deal in machines, engines, tools, instruments and mechanical and electrical supplies.

For a site, the company purchased 73 acres, a part of which had been devoted to a manufacturing enterprise by the Standard Chain Works of Pittsburg, Pa. The Pere Marquette Railway passes through the site, and there is a wharf on the river front.

The brass finishing building, the foundry and power plant are now in course of construction. The buildings are of concrete and steel, and are fireproof. The roofs are of the sawtooth type, with the most approved lighting and ventilating devices. The sides of the building are largely windows, with steel sash and ribbed glass. The plans contemplate the employment of 150 men at the start, and the output will reach \$150,000 annually.

Oscar B. Mueller, who is the general manager of the Canadian plant, has established his residence at Sarnia. He is also manager of the eastern division of the business in the United States, with headquarters in New York. He will continue in charge of the New York office. It is planned to manufacture in Canada everything manufactured in Decatur, and to add some other lines for which there is a demand in this country.

The officers of the Sarnia company are:—O. B. Mueller, president and general manager; G. G. Heiby, vice-president and superintendent; Adolph Mueller, treasurer; Fred L. Riggins, secretary. The directors are: Phillip Mueller, Fred

company, assistant general manager and assistant treasurer.

Richard Lan will be foreman of the foundry in Sarnia, and W. C. McIntyre, assistant foreman of nickel plating, polishing and buffing in the Decatur plant, will be foreman of the same department at Sarnia. C. W. Padgett, shipping clerk from the New York office takes charge of the new factory's shipping department and stock department.

Arthur Carroll goes into the upkeep of stock department in Sarnia, and P. W. Blair, foreman of the brass finishing department in Decatur, goes to the new plant as foreman of the same department. Robert Thrift has charge of the accounting, collections and credits, and C. P. Harry, of the advertising department in Decatur, goes into the sales department in Sarnia.

MASSEY-HARRIS CO., LTD., TORONTO.

WITH the completion of the extensions to the foundry of their headquarters plant the Massey-Harris Company will be enabled to greatly increase their output. The foundry will be one of the largest as well as one of the most modern in design to be found in Canada. The extension, now rapidly approaching completion, measures 238 feet long by 95 feet in width, which will make the total length of the foundry proper 528 feet

and the width 95 feet. With the new core department at one end and the cleaning department at the other, the length of the combined buildings is 913 feet. This new extension to the foundry has a rather unique feature, consisting of a basement for the storage of sand and other materials, and a traveling conveyor for delivering these at any point desired.

Four large cupolas, each 96 inches diameter, and having a melting capacity of 25 tons per hour, are being installed. Under ordinary conditions, only two cupolas will be used, the other two being held in reserve or used on alternate days, thus giving ample time to prepare the cupola, and the iron and fuel for charging. The iron and fuel for the cupolas are loaded on small cars, raised to the charging floor on electric elevators, and by means of transfer tables the material can be brought to the cupola, as required. The contents are deposited in the cupola by a pneumatic charging machine. Blast is provided by direct connected motor driven fans.



NEW PLANT OF THE CANADIAN STEEL FOUNDRIES, LTD.

THE largest steel foundry to go into operation in the Dominion during the past year was the new plant of the Canadian Steel Foundries, Ltd., at Longue Pointe, Montreal. This foundry started operation on July 4, 1912, and is now turning out 3,000 tons per month of acid open hearth castings. The firm manufactures locomotive frames, wheel centres, miscellaneous engine castings, double body and truck bolsters, high carbon rolls, gears, dredge buckets, etc., etc. In addition to the regular open hearth products, castings of manganese and vanadium steel are regularly produced. A specialty is made of high grade manganese steel switches, frogs, mates, diamonds and all intersection parts for steam and electric railroads. A large number of manganese castings for dredge work, mining and crushing machinery are also made.

The Foundry.

The foundry measures 436 feet long from north to south, and is 264 feet wide. It is divided into five aisles, one extending across the south end and four running longitudinally from this aisle to the north end of the building. Stock is loaded into charging boxes in the yard and brought into the foundry to the west aisle which is served by a 15-ton Dominion Bridge traveling crane. Stock is charged into furnaces by a Morgan 5-ton, 4-motor, high type charging machine. There are two 25-ton acid furnaces using oil fuel, and provision has been made for increasing this number if

necessary. The furnaces are of very heavy and substantial construction and are arranged to use either gas or oil. The regenerative furnaces are built with both gas and air chambers, the former being bricked up. Should the supply of oil be cut off or the price become prohibitive, a producer can be installed.

The Fettingling Shop.

After castings are poured and shaken out they go to the fettingling shop, which extends right across the south end of the building. For handling castings in this shop there is a 30-ton Morgan, and a 15-ton Dominion Bridge crane, together with a Whiting electric traveling wall jib. There is the usual equipment of compressed air chipping hammers and small machines. The cold saws consist of one 12-inch, two 20-inch and one 50-inch Newton, the two latter being driven by a 10 and 15 h.p. d.c. motor, respectively. Most noticeable of the larger machines are the Bertram 48-inch lathe direct driven by a 35 h.p. Canadian General Electric motor, and a special Morton traveling double head shaper with 40 ft. bed, specially designed for steel foundry work on frames, etc.

The two straightening presses are located in aisle A. One is a 170-ton press with a 10 h.p. d.c. motor, the other is 400-ton with a 25 h.p. motor. Both machines were built by John Bertram & Sons to the Canadian Steel Foundries' special design.

Machine Shop.

The machine shop has a total size of 203 feet by 86 feet, the entire area being served by two five-ton three-motor Niles-Bement-Pond cranes. The crane way is carried from the roof trusses, no central columns being used. This was done to secure free space for laying out railway intersections which are finished in this shop. The equipment differs from that of the ordinary machine shop, in that it consists largely of swing frame grinding machines. These are used for finishing manganese switches, diamonds, etc., which cannot be machined by steel tools on account of their hardness. The floor is of wooden blocks as is the pattern shop.

In addition to the swing frame grinders mentioned above, the more important equipment in the machine shop includes: a 48 in. x 48 in. x 12 ft. motor driven open side planer by the John Bertram & Sons Co.; one motor driven 6 ft. radial drill by the Canada Machinery Corporation; one belt driven 6 ft. radial drill of the same make; one 3 ft. belt driven radial drill, also by the Canada Machinery Corporation; one 14 in. Leblond engine lathe; one 14 in. quick change back geared lathe (Leblond); one 20 in. by 12 ft. engine lathe by the Hamilton Tool Works, Hamilton, Ohio; one No. 3

bolt cutter by Brown & Co., East Hampton, Conn.; two 20 in. vertical drills by A. A. Jones, Pollard & Shipman, Leicester, Eng.; one 6 in. high speed draw-cut saw by the Racine Tool & Machine Co., Racine, Wis.; and a motor-driven No. 4 floor grinder by the Bridgeport Safety Emery Wheel Co., Bridgeport, Conn. Other equipment will be added as required.

For further particulars of this fine foundry, readers are referred to the issue of "CANADIAN MACHINERY" for November, 1912, where it was fully described and illustrated.



FACTORY FOR GALVANIZING CONDUITS.

A NEW factory opened its doors for business at the beginning of this year, at the foot of Broadview Avenue, Toronto. The product is galvanized conduits, treated both inside and outside by a hot galvanized process. The firm goes under the name of the Greenfield Conduit Co., Ltd., with head office at 70 King street west, Toronto. The manufacturing rights for Canada were purchased at considerable cost from the inventor of the process, Col. Greenfield, New York, who is manufacturing a similar product in that city. The president of the Canadian concern is Mr. F. B. Johnston, of Toronto, and the secretary Mr. C. W. Bongard, of the same city. The advantages claimed by this company for their electric conduits is that when bent, the zinc does not peel off, and further, that being galvanized on both sides there is no possibility of the pipe rusting.

A large brick and steel building with a concrete floor, has been erected on Broadview avenue, 150 x 55 feet., and there is plenty of land in front to allow of extension, which it is expected will become necessary in the spring. The surplus ground is being used at present for storing pipe. In an annex to the main building is the pickling department, where all rust and dirt is first removed. From here the pipes pass to a zinc bath, and are carried by rollers along an iron bar. En route they are treated by compressed air, which forces all surplus zinc away, and the pipe receives its final cleaning from an asbestos tassel over which it passes. The finished product is thrown automatically into heaps. The pipes are threaded in the same building, and finished complete, ready for use.

Mr. Fridolin Polzer, superintendent, who came from New York, to erect and manage the plant, claims that he can turn out 70,000 feet a day, in sizes from 1/2 to 3 inches.

There is a machine shop in connection

Steel

Perfect
CASTINGS

That Assure
The Greatest Durability

Let Us
Quote Prices



We Guarantee
Satisfaction

DOMINION
Steel Castings Co.

HAMILTON, ONTARIO

Castings

The advertiser would like to know where you saw his advertisement—tell him.

with the factory. Power is supplied from independent motors, which aggregate 50 horse power. The cost of the building with equipment was between \$75,000 and \$100,000.



MARSH & HENTHORN, NEW PLANT, BELLEVILLE, ONT.

ONE of the most striking features in the rapid development and up-building of this country is the all important part which the hoisting engine plays in connection therewith. The firm of Marsh & Henthorn, Ltd., Belleville, who were among the first in the Dominion to recognize this fact and take advantage of it by constructing hoisting machinery, have since specialized in this phase of engineering work, with the re-

point of view, being on the north side of the beautiful Bay of Quinte and adjacent to the Canadian Northern and C.P.R. main lines. The buildings which are now nearly completed embody all the best features of modern manufacturing plant design and construction, provision being made for future extension on each separate building.

The accompanying plan shows a general layout of the buildings. A spur track runs alongside of the foundry so that sand, iron, coke, etc., can be unloaded directly into the bins. This track also runs through the east end of the erecting and boiler shops, facilitating the handling of raw material and shipping, and cutting down expenses to a minimum. Traveling cranes are also provided to run the whole length of these two shops. All the shops are uni-

provision is also made for a sand blast apparatus.

In the machine shop there is a large centre bay served by a heavy duty traveling crane, under which a few of the heaviest tools are located. The two side bays will be equipped with machine tools and fitters' benches, and all heavy engines, etc., will be entered at the end nearest the tracks, where they will be tested, finally painted and finished ready for shipping.

The stores and tool room is built between the machine and blacksmith shops, and as will be seen, is about centrally located.

The blacksmith shop will be equipped with four forges, a 600-lb. hammer driven by compressed air, also a shear and punching machine and an electrically driven blower. Specially designed racks will be used for storing bar iron.

The boiler shop is provided with all the latest tools for the rapid construction of boiler and tank work. The large bay, which is traversed by a heavy traveling crane, is equipped with all the heavy tools, comprising clamps, rolls, punch and shears. At the extreme west end a new type 70-ton deep throat pneumatic rivetter is located, above which is a tower 60 feet high. Boilers, tanks, flumes, etc., will be hoisted up into this tower and lowered into the riveter which forms the rivet head and completes the riveting at one stroke with a compression of 70 tons. The side bay is equipped with drilling machines, emery wheels, small punches and special tools, also a deep throat horizontal punch for special boiler firebox work, etc. An electrically driven two-stage compressor is also located in an enclosure under this bay, and this will supply compressed air to the various hammers, reamers, chippers and riveters. A large jib crane is fitted outside the boiler shop alongside the track for handling large tank work, etc.

The whole factory is heated from a central heating plant on the vacuum system, a large boiler and the necessary pumps being located in the power house.

The whole of the works will be electric driven, with separate motors for each department. The power plant will consist of eight alternating current motors, ranging from 60 h.p. to 5 h.p. Illumination will also be electric, Tungsten lamps being used throughout.

In the matters of lighting, ventilation, heating and fire protection, the factory represents the latest word in efficiency and safeguarding of the health and comfort of employees. Over fifty different types and sizes of hoist are made to suit

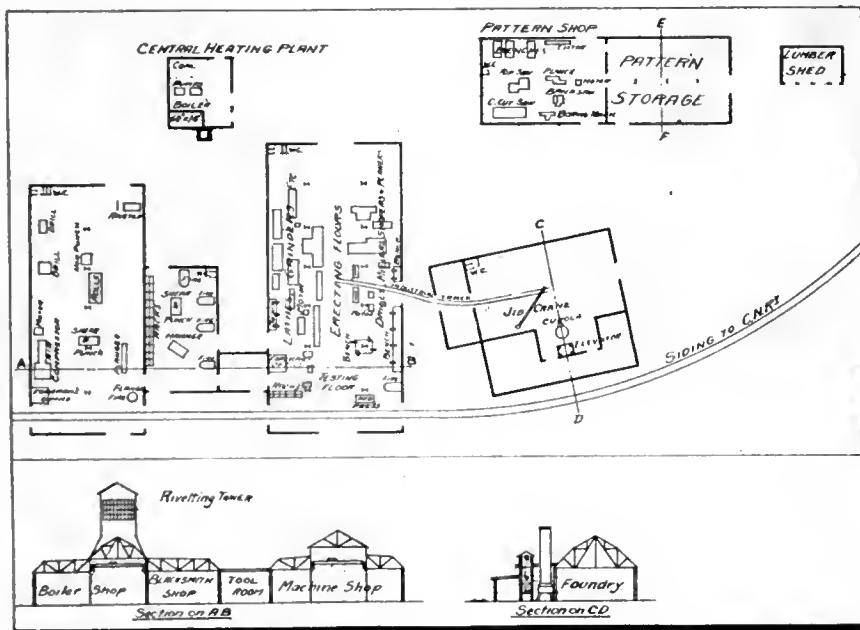

MARSH & HENTHORN, LTD., BELLEVILLE, ONT. PLAN OF THE WORKS.

sult that to-day their hoisting engines are now in use everywhere. On almost every large building contract may be found one or more hoists made by this concern. Railway contractors also favor this hoist, and large numbers are used throughout the mining camps; in fact, wherever there is any development going on, you will find somewhere in the neighborhood a Marsh & Henthorn hoisting engine. The demand during the last few years has been so great that the company, while continually adding new machinery to their old plant, have found the latter to be entirely too small to keep abreast with the times, and they have been forced to build a complete new factory of the most modern type.

The site covers nine acres, and its location is exceptionally good, presenting many advantages from a manufacturing

point of view; steel sash windows being employed throughout.

The pattern shop and pattern storage are of absolutely fire proof construction; the pattern storage being two-stories high with concrete roof and floors.

The foundry is specially designed for the class of work required, and an industrial track runs from this department into and under the crane in the machine shop, so that large castings may be lifted with the crane in the foundry, placed on the car and handled again with the machine shop crane, thus eliminating all heavy manual labor. The cupola is of the latest type, and the charging platform is fed by an elevator, thus obviating heavy lifting on the part of the attendant. The cleaning room is fitted with a cylinder mill and emery wheels;

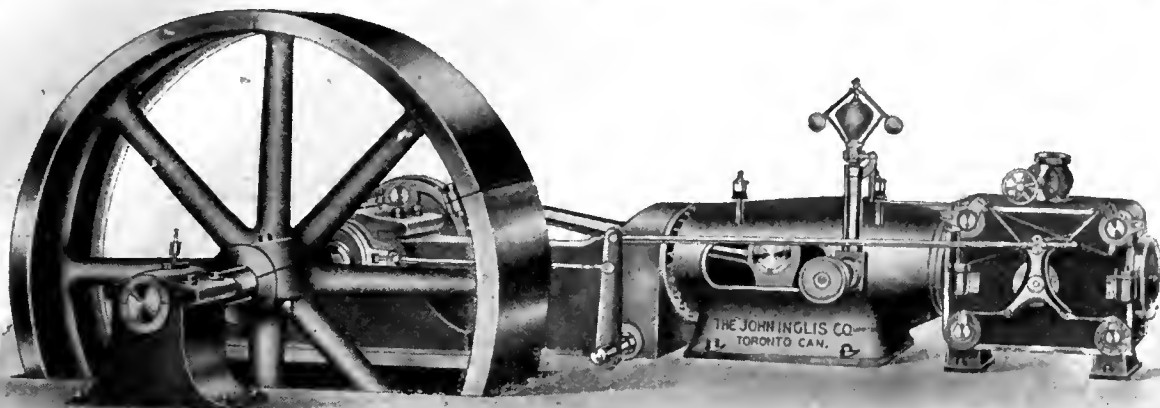

Other People's Opinions Are What Count

Anything we would say about our power plant equipment might be considered biased.

We acknowledge no superiors in the art of building high efficiency pumps, engines and boilers, but we would prefer to let our customers speak for us.

If you wish to instal a complete power plant or a new unit, write us at once, and we will be pleased to submit you names of previous purchasers for reference.

THE JOHN INGLIS COMPANY, Ltd.

Engineers and
Boilermakers

Strachan Ave., TORONTO

various requirements, while another leading specialty is the manufacture of all kinds of tanks, contractors' dump buckets and dump cars.

Marsh & Henthorn are, we understand, the largest makers of small vertical boilers in Canada, having just closed a single order for 66 of this type. In the near future, we will give a more detailed description, dealing with the equipment, and showing the methods of manufacture employed in this interesting and up-to-date plant.

STEEL WORKS AT ST. JOHN, N.B.

THE capital required for the establishment of the proposed iron and steel works at St. John, N.B., has been fully subscribed by English financiers, according to the latest reports. Arrangements with Messrs. Drummond, of Montreal, to transfer their works from Londonderry to St. John, and to establish a modern plant in connection with the big scheme, have been completed.

There have been rumors at one time and another of considerable ore in New Brunswick, and it may be that it is within sufficient distance of St. John to justify the establishment of a steel plant.

OGDEN SHOPS OF THE C.P.R., NEAR CALGARY.

THE new shops of the Canadian Pacific Railway at Ogden, near Calgary, Alta., are now rapidly nearing completion and a commencement is being made with the installation of the equipment. The site is approximately in the shape of an equilateral triangle with the apex cut off, and allows ample space for doubling the size of the plant when required.

The locomotive shop, machine shop, blacksmith shop and boiler shop are all grouped together in one large building running perpendicularly to the base of the triangle. This, in common with the other principal buildings, is a steel framed structure and measures 773 ft. by 305 ft. The locomotive shop has 35 transverse pits served by a 120-ton crane, with a 10-ton messenger crane below. There is also a liberal provision of jib cranes on the shop columns.

The heavy and light machine bays run parallel to the erecting shop on one side, while on the opposite side is the blacksmiths' shop and boiler shop, which lie end to end with one another. The blacksmiths' shop is in two bays, that next to the erecting shop containing the hammers and forges, while the other accommodates the forging machines, bull-

dozers, etc., together with the attendant furnaces.

The boiler shop is also in two bays, that next to the erecting shop is served by a 15-ton traveler and forms the marking off floor and assembling department; the other bay contains the machine tool equipment. The whole of this large building, which covers considerably more than 5 acres, is heated by indirect radiation, the hot air being distributed by underground ducts.

All tracks run at right angles to the big shop, and at one end of it, and between it and the stores building, there is a large stock yard 1,260 ft. long, served by a 10-ton crane of 80 ft. span. This serves for the receipt of raw material and for the shipping of scrap. The tender shop is a separate building having the shape of a letter L. One leg is devoted to tender tank repairs and the other is occupied by machine tools such as wheel lathes, axles lathes, car wheel borers, etc.

The coach repair and paint shop, 362 ft. by 146 ft., contains 15 tracks. This building is of mill construction similar to the company's coach shops at Montreal. In addition to serving as a coach building shop, it provides space for an air-brake shop, upholstering shop, varnishing room, etc. When necessary, a second

FIRE RISKS OF FOUNDRIES.

Canadian Foundryman
Dec. 1912

of an exhaustive report. It was shown, among other things, that the insurance rate per \$100 risk was immensely lower where adequate means for discovering and fighting fire had been taken than in other cases. For instance, irrespective of building construction, the foundries provided with automatic sprinklers had an average rate of only 10 1/2% as compared with 96 1/2% for the best type of construction, but without sprinklers. The difference here is tremendous, and has been made the basis of recommendations that those foundries which are not satisfactorily protected should take advantage of the means at hand to safeguard themselves from disastrous fire, and, at the same time, reduce their insurance outlay. It has been shown that the premium reduction can be depended upon, in many cases, to pay for the complete equipment within a period of four or five years, after which there is clear gain.

*How Much
Would
Fire Sprinklers
Save You?*

What is good for the protection of Foundries is good for the protection of shop, factory and office.

No manufacturer should have his plant unprotected when the most efficient protection on earth will actually pay for its installation by the saving of insurance premiums.



**Manufacturers' Automatic
Sprinklers**

Write for an Estimate for Equipping Your Plant

GENERAL FIRE EQUIPMENT CO., Limited

72 Queen, St. East

Toronto, Can.

The advertiser would like to know where you saw his advertisement—tell him.

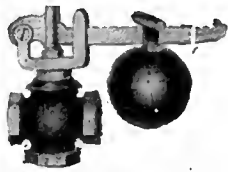

Safety Valve—Lever and Weight Type.



Oil Cup—Quick Stop, Sight Feed



Gauge Cock.

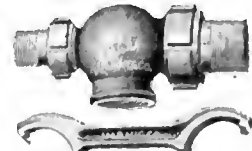

"Gem" Ejector.



Pop Safety Valve.

Engineers' Goods of the Utmost Reliability



Check Valve with Drip Cock.

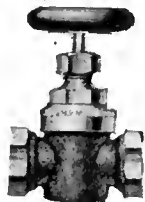

Quick Opening Radiator Valve

Cuts illustrate a few of our products in the line of boiler room accessories.

We submit our goods as first in quality of material and workmanship, and guarantee them to "Stand Up" against the most rigid test.

We solicit your inquiries for anything in steam and valve goods (lines).

Our Prices are Right for good Quality
ASK FOR CATALOG



Grease Cup.

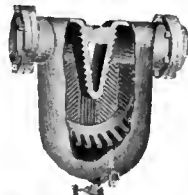

Steam and Oil Separator.

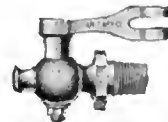

Forked Lever Air Cock



Steam Whistle

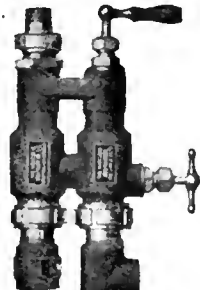

Hancock Insulator.



Relief Valve.

The James Morrison Brass Mfg. Co., Ltd.

93-97 Adelaide Street West, TORONTO

each shop will be built on the opposite side of the transfer table pit, which will thus serve both.

The planing mill, 300 x 80 ft., is near the freight car repair shop, and has its wood-working machinery carefully laid out so that lumber passes continuously forward from one end of the mill to the other. The freight car repair shop, 303 ft. by 231 ft., has eight through tracks and can accommodate 48 cars. Along one side of the shop is a bay, 50 ft. wide, containing the heating plant and car blacksmiths' shop.

Power for operating the plant is purchased from an outside source, but there is a central boiler house to furnish steam for the forge hammers and for heating and other purposes. This boiler house is situated about 200 feet from the planing mill, the refuse from which is here consumed.

The foundry and pattern shop are situated parallel with one another towards the south-east corner of the site. The pattern shop measures 98 x 31 ft., and the foundry 203 x 80 ft. They stand at some considerable distance from the main locomotive shop to allow for extensions to the latter in the future.

The plans for the buildings and the general layout were got out by Westinghouse, Church, Kerr & Co., New York, Montreal and Vancouver, who are also constructing the buildings and supplying the equipment.

WESTERN DRY DOCK AND SHIP-BUILDING COMPANY.

THE Western Dry Dock and Ship-building Co., Port Arthur, Ont., advise us that during the past summer they have erected a two-storey joiner shop, 105 x 50 ft., equipped with all the latest wood-working machinery. They have also built a warehouse, 60 x 100 ft., of brick and steel structural work; a power house of brick and steel 90 x 50 ft.; also a machine shop, which is nearing completion, 90 x 180 ft., built of structural steel and brick, equipped with two 15-ton electric traveling cranes and one 3-ton traveling crane, together with modern machinery. During the year they delivered one Welland Canal-size package freighter for the Inter-Lake & Ocean Navigation Co., Ltd., of which Mr. J. W. Norcross is manager. They have also built one 200 ft. stern wheel freight and passenger boat to the order of the Canadian Pacific Railway, for its Kootenay Lake service, same having been shipped from Port Arthur to Nelson, B.C. in knock-down condition and erected there for launching. There is under contract another Welland Canal-size package freighter, a duplicate and for the same parties as the one above

mentioned. Construction has also commenced on a passenger boat for the Northern Navigation Co., to be built on the same general lines as the steamer Harmonic; 385 ft. long, 52 ft. moulded breadth, and 28 ft. 9 inches moulded depth, for delivery this year. In addition to the foregoing, a large amount of repair work has been put through.

THE SCHAAKE MACHINE WORKS.

THE Schaaque Machine Works, New Westminster, B.C., have begun the construction of an entirely new plant on a site of five acres recently purchased in the city of New Westminster. There is a water frontage of 650 feet, and railway trackage in the rear. The main machine shop building will be 90 x 300 ft., the store room, 100 x 150 ft.; foundry 80 x 200 ft.; pattern shop and storage 95 x 100 ft. (two storeys); blacksmith shop 40 x 60 ft.; office building 40 x 60 suit the economical construction of the most modern tools that can be bought to suit the economical construction of our product—saw and shingle mill machinery, canning machinery, gasoline and Diesel oil engines. The investment in plant and buildings will be in the neighborhood of \$400,000, and the buildings are arranged to allow for extension. There will be a large wharf and frontage for docking vessels, and railroad trackage directly in and around the buildings, which connects with three trans-continental roads.

NEW METAL SASH FACTORY.

PETERBOROUGH, Ont., is fortunate in securing a new factory—that of Henry Hope & Sons, Ltd., of Birmingham, England, who will erect a machine shop, about 100 x 200 ft. in which to manufacture metal sashes. About fifty men will be employed at the beginning. Messrs. Sproatt & Rolph, of Toronto, are the architects. H. D. Hope, president of the English company is also president of the Canadian concern. A. L. Young, of Toronto, is vice-president, secretary-treasurer and manager. David McGill, of Montreal, is a director.

The site of the new factory, which has been given by the town of Peterborough, is bounded by Park, Romaine and Monaghan streets, and is about 2,000 x 220 ft. It is served by the C.P.R. and G.T.R. The plant will be a model daylight one, with employes' lunch, rest rooms, recreation grounds, etc. Only the steel sash and patent roof glazing will be manufactured here to begin with.

Mr. A. L. Young, vice-president of the company, was connected for twenty-

seven years with the Aikenhead Hardware, Ltd., of Toronto.

LAKE SUPERIOR CORPORATION.

AT the annual meeting of the shareholders of the Lake Superior Corporation, held at Camden, N.J., recently, the President, Mr. T. J. Drummond, in his annual address, reviewed the progress of the Corporation for the year ending June 30, 1912. His speech showed that the progress of the Corporation during the past year had been good, the operations of its subsidiary companies successful, and pointed out that the prospects for the coming year were of the brightest. He said in part that the earnings from the operations of the subsidiary companies for the year amounted to \$1,579,000, an increase of 30 per cent. over last year, and that there was a balance over and above bond interest of \$1,148,000. Under the favorable conditions existing, the directors had been able to declare the full interest of 5 per cent. on the income bonds, as against 2½ per cent. paid in 1910-11, 1909-10.

The construction of the Algoma Central Railway had been completed to the main line of the Canadian Pacific; the extension to the Canadian Northern would be completed within a few months and that to the Grand Trunk Pacific by the fall this year. The prospects of the railway were good. The extension of the Algoma Eastern Railway was being pushed on, and business on the part of the line in operation showed an increase, and was satisfactory.

The completion and commencement of operation of the paper mills of the Lake Superior Paper Company would materially increase the earnings of the subsidiary companies of the Corporation. As the paper company was a large user of power and a large consumer of wood.

The most important development of the year had been the successful flotation of the Algoma Steel Corporation, which took over the plants, properties and business of the Algoma Steel Company, the Lake Superior Power Company, and other subsidiaries. As a result of this consolidation the short-term notes (\$5,000,000) of the corporation had been redeemed, and the finances of the Corporation put on a sound and permanent basis. New blooming and rail mills had been installed, and the output of the steel plant very materially increased, but in spite of this it was difficult to meet the existing demand in Canada for steel products, and still further extensions would be necessary. The president reminded the shareholders of the great potential value of the mines and lands owned by the subsidiary companies, and that the Corporation owned equities in

3,000,000 acres of land, most of which was covered by high-grade pulpwood, from which revenues were being obtained, and that they had already located on their land iron ore deposits of great value. The earnings for the first two months of the present fiscal year had proved most satisfactory, and orders for the steel products were such as to insure the operations of the plants at full capacity.

which they find a market. The firm has been supplying the Canadian trade from the Buffalo plant, but will now do their manufacturing in Canada. The plans at present contemplate one blast furnace of a capacity of about 350 tons per day, to be increased from time to time. They will also engage in the manufacture of some finished products from their own pig iron, although plans on this point are indefinite at present.

THE NATIONAL IRON WORKS.

THE National Iron Works, Ltd., Toronto, manufacturers of cast iron water and gas pipe, are making an extension to their present foundry which will more than double its capacity. This addition is for the manufacture of cast iron water and gas pipe from 12 inches to 60 inches in diameter, and it is hoped it will be completed not later than September, 1913. Their total output will then be in the neighborhood of 175 tons per day. They are also extending their present docks 1,000 feet. These docks are of concrete and steel construction.

FURNACE FOR PORT COLBORNE.

A MODERN blast furnace is being erected at Port Colborne, Ont., by the Buffalo Union Furnace Co., of Buffalo, N.Y., on a site partly under lease from the Government, measuring 60 acres. It is their intention to manufacture high grade foundry, malleable and basic pig iron, and other grades for

Classified Advertisements

MACHINERY FOR SALE

MACHINERY FOR SALE NEW AND SECOND-HAND machinery, engines, boilers, wood and iron working machinery and supplies. Write, stating what you require. Prompt and careful attention to all inquiries. The Advance Machine Works Co., Montreal, Que.

BELTING, PACKING, ETC.

BELTING FOR SALE — 800,000 FEET of best quality leather, rubber, hair and canvas belting, bought from bankrupt manufacturers at 25 to 75 per cent. less than the regular value. Also a large quantity of slightly used belting, piping, chains, rails, pulleys, hangers, cotton waste, etc., at very low prices. Send for catalogue, Imperial Belting & Supply Co., 5 Queen Street, Montreal.

BELTING, RUBBER, CANVAS AND LEATHER, hose packing, blacksmith's and mill supplies at lowest price. N. Smith, 138 York Street, Toronto. (21f)

MANUFACTURING CENTRES

FREE FACTORY SITES — SEVEN RAILROADS, deep water, Niagara power, natural gas, low taxation, abundant labor. Welland, Ontario. B. J. McCormick. (12y)

WE ARE IN A POSITION TO FURNISH castings, light and heavy, preferably heavy. We can make prompt deliveries, inquiries solicited, Pollard Manufacturing Co., Ltd., Niagara Falls, Ontario. (3)

AGENTS WANTED.

to sell our various AUTOMATIC ENGINE STOP and SPEED LIMIT SYSTEMS. Over 4,000 installations. There are no Engine Stops manufactured in Canada. 20% commission. CONSOLIDATED ENGINE STOP CO., 350 West 38th St., New York City, N.Y.

Second Hand Machinery

ONE 150 H.P. PRODUCER ENGINE
Can be changed to Natural Gas.

FOUR 50 K.W. GENERATORS

ONE 50 H.P. PRODUCER ENGINE
Direct Connected to Generator

ONE 12 x 12 AIR COMPRESSOR
Fair Condition

ONE 3 VS. 3 CYLINDER
MILWAUKEE BRAKE & ELECTRIC
CO. AIR COMPRESSOR
150 cubic feet.
Now running.

TWO STURTEVANT 54 IN. HEATING
SYSTEMS COMPLETE

TWO 3-TON MOTOR TRUCKS

Canadian Fairbanks-Morse Co.
Mfg. Dept.

1379 West Bloor St., TORONTO



"Angle or Globe"

"AUTOMATIC"
Cushion Non-Return and Triple-Acting Valves
"Work Both Ways"
Largest Steel Co. in the world ordered over 1000 of our valves for the protection of their **"Power Stations"**

References
Canadian Northern Ry. T. Eaton Co. Toronto, Can.
Canadian Pacific Railway City of Vancouver, B.C.
Armour & Co. U. S. Steel Corp. National Tube Co. Illinois Steel Co.



"AUTOMATIC"
"The Controlling Altitude Valve"

maintain a uniform stage of water in stand-pipes, reservoir or tanks.

No overflow in case of fire pressure. Valves automatically closed by water or electricity.

"Quick Closing Valves"
"Sandpipe Valves"

Automatic Valves
For Steam and Water Service

Anderson Reducing Valves for Steam or Water.



1233 Fulton Building PITTSBURGH, PA.

GOLDEN-ANDERSON VALVE SPECIALTY COMPANY



MACHINE DIVIDED RULES

ARE STANDARDS OF ACCURACY AND MATERIALS

Our catalog tells about their many superior features. It's sent free on request.

THE LUFKIN RULE CO. OF CANADA, LTD. WINDSOR, ONT.

The advertiser would like to know where you saw his advertisement—tell him.

INDUSTRIAL and CONSTRUCTION NEWS

Establishment or Enlargement of Factories, Mills, Power Plants, Etc.; Construction of Railways, Bridges, Etc.; Municipal Undertakings; Mining News.

FOUNDRY AND MACHINE SHOP.

Ottawa, Ont.—An \$80,000 contract has been let by the Canadian Government to the Canadian Bridge Co. for the construction of steel bridge work over the Managnish river and Canyon creek, on the line of the National Transcontinental railway.

Calgary, Alta.—Thirty engines per month will be the capacity of the new Canadian Pacific railway repair shops which will be finished at the end of the year. The erecting of these shops has called for an expenditure of \$2,000,000.

Moose Jaw, Sask.—New boilers have been erected at the city power house. The roof trusses were supplied by the Saskatchewan Bridge and Iron Works.

Vancouver, B.C.—Fire almost completely destroyed the plant of the Hoffer Motor Boat Co. here, December 11. The loss will be about \$14,000. The firm carried about \$8,000 insurance.

Leamington, Ont.—The Detroit Motor Cycle Co. recently met the business men here and proposed to establish a factory in this town. A committee was sent to examine the plant in Detroit.

Brandon, Man.—The Emerson-Brantingham Co., Rockford, Ill., will establish a factory in Brandon, Man., to manufacture agricultural implements.

Petrolia, Ont.—The Petrolia Motor Car Co. plans an addition to its automobile factory at Petrolia, Ont. A by-law will be submitted to the tax payers to grant a \$10,000 bonus for the extension.

Kingsville, Ont.—R. F. Greene & Co., is building an addition to its foundry and machine shop at Kingsville, Ont., and will need new foundry and machine shop equipment.

Quebec, Que.—The Quebec Structural Steel Co., Ltd., will next spring build a steel manufacturing plant to cost \$300,000 at Quebec, Que. The company will manufacture structural steel beams.

Guelph, Ont.—The Independent Tire Co., of Guelph, Ont., has ordered five carloads of machinery from the Farrel Foundry & Machine Co., of Ansonia, Conn.

Portage La Prairie, Man.—The Economy Foundry Co., with works at Portage La Prairie, Man., and office at Winnipeg, advises that it is now operating a foundry, manufacturing light and heavy gray iron castings. The company also intends to operate another cupola on semi-steel castings. It is making machine castings of every description, heavy sewer castings, water works supplies and structural castings for buildings. In addition to its foundry the company has a well equipped pattern shop and machine shop.

Montreal, Que.—The Canadian Car & Foundry Co., Ltd., Montreal, Que., reports that it has at the close of the present year unfilled orders to the amount of \$16,000,000. The annual meeting of the company took place in Montreal, Que., last week when a surplus of \$1,056,334.25 for the year was reported. The company has under way extensive works at Fort William, Ont.

Hamilton, Ont.—The Canada Screw Co., Hamilton, Ont., is having two small additions, each 80 x 40 feet, built to its plant.

Saskatoon, Sask.—It is reported that certain members of the Slav colony will invest

the sum of \$50,000 in a plant for the manufacture of all varieties of iron and sheet steel articles. Mr. C. J. Alexander is interested in this project, which is to be known as the Toll Corporation, Ltd.

Peterborough, Ont.—Henry Hope and Sons, Ltd., of Birmingham, England, will build a factory here for the manufacture of steel sash and roofing. It will be north of and adjacent to the De Laval Dairy Supply Co. on Park St. They will employ at least fifty hands to start with. The concern is capitalized at \$240,000, \$120,000 of which is preferred stock. The new factory, 80 x 200 ft., will be of brick and steel, one storey high, and will cost altogether \$60,000. The city grants a free site and exemption from taxes for ten years.

Peterborough, Ont.—The Peterborough Machine and Lubrication Co., Ltd., has been incorporated, with E. R. Wilson and Alex. Gillespie as two of the provisional directors. The capital is \$60,000. The company will manufacture and deal in dies, tools, motors, engines, launches, boats, automobiles, and will manufacture the automatic grease cups invented by John Francis Lewis.

Oil Springs, Ont.—Mr. Robert McGregor, of Sarnia, a former resident here, has purchased the machine shop of Mr. R. A. Holme.

Owen Sound, Ont.—The Northern Bolt & Screw Co.'s building is finished, and the machinery is being installed. West of the bolt works, the Wire and Nail Factory is nearing completion, and west of the nail works is the power house, of solid concrete, in which the boilers have been installed. The west end of the old C.P.R. No. 3 shed will be used as a keg and box factory. Both plants were expected to be running by the first of the year.

Magog, Que.—The Magog Foundry Co. will equip a new foundry at a cost of \$50,000.

Kenora, Ont.—The Thurber Co. will equip a machine shop, costing \$25,000, in connection with its gold-extracting plant. James Weldman is the manager.

Lindsay, Ont.—Madison Williams & Son are having plans prepared for a new three-storey garage and repair shop, to be erected here.

London, Ont.—The London Motor Sales Co., London, Ont., will erect a large garage and repair shop. New equipment, including an electric elevator, will be purchased. Chas. Abbott is the manager.

St. Thomas, Ont.—Bids will shortly be asked by the Erie Iron Works, St. Thomas, Ont., for an addition to its plant. Much new machinery will be installed.

Regina, Sask.—The Minneapolis Threshing Co., Minneapolis, Minn., plans to erect a branch factory for the manufacture of its products at Regina, Sask. T. H. Roney is the manager.

Hanover, Ont.—The Fisher Machinery Co., Ltd., recently incorporated with a capital of \$500,000, will erect a foundry and machine shop. Wm. H. and Arthur W. Fisher, David and Jacob S. Knechtel, and B. P. Ahrens are incorporators.

Ottawa, Ont.—The Campbell Steel & Iron Co., Ltd., will erect a factory on Carling Ave., to cost \$40,000. New machinery will be purchased.

Toronto, Ont.—The Bateman-Wilkinson Co., Ltd., has been incorporated with an author-



The Commissioners of the Transcontinental Railway

NOTICE TO CONTRACTORS

Tenders for Machines, Tools, Appliances, Motors, Furnaces, Cranes, Etc.

SEALED TENDERS, addressed to the undersigned, and marked on the envelope, "Tender for Machines, Tools, Appliances, Motors, Furnaces, Cranes, Etc.," will be received at the office of the Commissioners of the National Transcontinental Railway at Ottawa, until twelve o'clock noon of the Thirteenth day of February, 1913, for the furnishing and delivery of the Machines, Tools, Appliances, Motors, Furnaces, Cranes, Etc., required for the equipment of the Car Department Shops, Transcona Plant, of the Commissioners of the National Transcontinental Railway, at Transcona, Manitoba.

Tenders will be considered for any portion, or all of the equipment.

Specifications and forms of tender may be obtained at the office of Mr. W. J. Press, Mechanical Engineer, Ottawa, Ontario.

Persons tendering are notified that tenders will not be considered unless made on the printed forms supplied by the Commissioners.

Each tender must be signed and sealed by all the parties to the tender, and witnessed and be accompanied by an accepted cheque on a Chartered Bank of the Dominion of Canada, payable to the Commissioners of the Transcontinental Railway, for a sum equal to ten per cent. (10%) of the amount of the tender.

Any person whose tender is accepted shall, within ten days after the acceptance thereof, sign the contract, specifications and other documents required to be signed, and in any case of refusal or failure on the part of the party whose tender is accepted to complete and execute the contract with the Commissioners, the said cheque shall be forfeited to the Commissioners as liquidated damages for such refusal or failure, and all contract right acquired by the acceptance of the tender shall be forfeited.

The cheques deposited by parties whose tenders are accepted will be deposited to the credit of the Receiver General of Canada as security for the due and faithful performance of the contract according to its terms.

The cheques deposited by parties whose tenders are rejected will be returned within ten days after the signing of the contract.

The right is reserved to reject any or all tenders.

By order,

P. E. RYAN,
Secretary.

The Commissioners of the Transcontinental Railway.

Dated at Ottawa, December 11th, 1912.

Newspapers inserting this advertisement without authority from the Commissioners will not be paid for it.—32910.

Ernest Scott

145 Bleury St. MONTREAL

Machinist and Tool Maker

Dies for Sheet Metal Work.
Stampings and Light
Manufacturing

Special Machinery Designed
and Made to Order.

HARKER & KEMBLEY

Machinists and Brassfinishers

Brass and Aluminum
Castings, Fire Dept.
Supplies, all kinds of
special and experi-
mental work.

81 Peter Street, Toronto.

Phone Adelaide 1031

The George White & Sons Company, London, Ontario

Staff Article

A description of the works of an old established firm building threshing machinery, traction engines, etc. The plant has been gradually built up to its present size, the foundry being the latest addition. The company maintain two branches in the West and have agencies in all the principal cities and towns in the grain growing districts of Canada.

THE George White & Sons Co., Ltd., are well known as makers of high-class portable traction and stationary engines and grain threshing machinery; and their outfits may be found in all parts of the prairie provinces and also Eastern Canada. They have a fine plant at London, Ont., and large warehouses at Brandon, Man., and Moose Jaw, Sask. The firm has grown up from small beginnings, having been founded by Mr. Geo. White, Sr., who came to Canada from Devonshire, England, in 1856, with practically no capital at his command. He settled in London, Ont., and

Geo. White gradually took his numerous family of sons into the business with him.

By 1904, the company found themselves very much cramped in their King Street premises and it became necessary to move to more spacious quarters. A suitable site was secured in the eastern part of the city, alongside the Grand Trunk Railway tracks. Here the nucleus of a large engineering works was at once erected and has been gradually added to, until it reached its present size at the end of 1911, when the present foundry was built. The plant covers

ing and heavier parts are made, and the whole machine assembled on the ground floor. The shop has large window areas and artificial illumination is by 150-watt tungsten lamps. An illustration of the planing mill is given on page 66. It is a well-lighted shop and contains a full equipment of modern wood-working machinery. The latter is operated from line shafting, the whole shop being driven by a small horizontal Corliss steam engine. Each machine has its entters provided with a hood connected to a central exhaust fan, which gathers up all chips and sawdust and delivers



VIEW OF WORKS. THE GEO. WHITE & SONS, CO., LTD., LONDON, ONT.

immediately secured land at what is now 71-76 King St. East, for which he had to give a mortgage. Mr. White here commenced the building of wagons, buggies and light agricultural machinery. A few years later he took up the manufacture of small stationary engines and boilers and, as time went on, developed a portable engine for threshing purposes.

The business at King Street continued to extend, and in 1890 the patterns, templets and goodwill of the McPherson Mfg. Co., of Fingal, Ont., for the manufacture of grain threshing machinery, were purchased. This gave a fresh impetus to the business which continued to steadily increase during the next ten or twelve years, in which period Mr.

an area of about 9 acres and consists of four main buildings, viz: planing mill and separator shop, finished stores building, engineering shop, and office building. Their relative positions are shown on the plan of the works.

The Planing Mill.

The planing mill is in a brick building 200 ft. long by 140 ft. wide. It is divided into two parts, each 100 ft. long, by a brick wall fitted with fire doors. One half forms the planing mill and has one storey only, while the other half is a two storey building and forms the separator (thresher) department. On the upper floor of the latter, the lighter parts, such as chafers, are manufactured; while the fram-

same to the boilers which supply steam for the engine. This building is heated by indirect radiation on the overhead system, the installation having been put in by Sheldons, Ltd., Galt. The shop is lighted by incandescant gas arcs, supplemented by drop lights at each individual machine.

Finished Stores.

This is a brick building, 211 x 133 ft., with a saw tooth roof of five pitches. Here are stored, previous to shipment, the finished traction engines, threshers, portable engines, etc. Along the north side of the building is a depressed standard gauge track for shipping purposes. This track brings the flat cars on a level with the floor, enabling the thresh-

ing engines, etc., to be easily run onto them.

The Main Shop.

The main shop is built of hollow concrete blocks, as made by the Ideal Concrete Machinery Co., and is in the shape of the letter U, the two legs pointing north. The east leg forms the foundry and the west leg the boiler shop, blacksmith shop and erecting shop and stock room, while the connecting bay is the machine shop. A railway siding runs

ning the whole length of the building. The centre bay is served by a 10-ton electric crane operated from floor level. This is by Geo. Anderson & Co., Ltd., Montreal, and by means of special crane doors can pass out at the north end of the building in order to unload material from cars on the track outside. The middle bay of the shop is not much used for manufacturing purposes, but forms a crane midway for the transference of material from one department to an-

248 feet long by 100 ft. wide, the side bays being 37 ft. and the centre bay 26 ft. Heating is by indirect radiation on the Sheldon system. A concrete duct runs down the middle of each shop and 15-inch tile ducts branch off from this to the foot of every alternate column, the bases of which are formed of a hollow casting with large openings on opposite sides. In this way the heated air issues at floor level with very efficient and economical results. Economy in



A VIEW IN THE MACHINE SHOP.



INTERIOR OF PLANING MILL.

across the top end of the east and west legs, so that pig iron for the foundry and steel bars, plates, etc., for the boiler shop and smithy, are unloaded at the nearest point to their eventual destination.

The west bay, as above mentioned, is divided into several departments, viz., the boiler shop, blacksmith and wheel shop, and erecting shop. Each shop is of heavy mill construction and is in three bays; a glazed monitor roof run-

other. Manufacturing is therefore carried on principally in the two side bays only, each department being separated from its neighbors by partition walls. These run out into the centre bay, it having been the original intention to provide doors between each section of the shop. However, there would have been no great advantage gained by so doing, and the idea was never carried out.

This west leg of the building measures

heating is especially important here, since the shop is electrically driven by power purchased from outside sources; consequently, there is no exhaust steam available for heating and live steam has to be generated for the purpose.

All departments in this main building are artificially lighted by 400 c.p. gas arcs, with the exception of the foundry.

The Boiler Shop.

The boiler work turned out by the company impresses one very favorably,

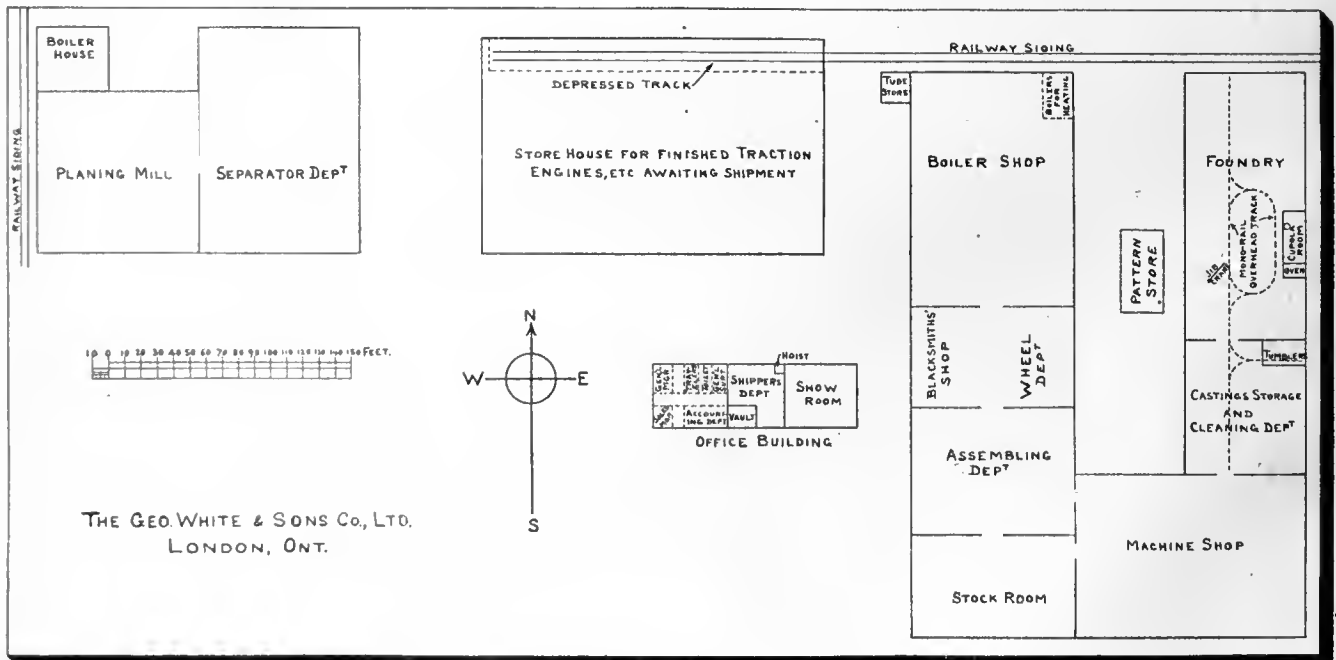

LAYOUT OF THE PLANT.

the workmanship and general finish being of a high order. The orderliness of the shop is also very noticeable; all plates are stored vertically in neat racks of W. I. pipe and are classified according to their thickness and future use. The boiler makers and boiler-smiths work on the west side of the shop, while in the opposite bay are the rolls, punches, etc. The equipment is all belt-driven and includes a McGregor-Gourlay punch, with 48-inch throat; Lennox rotary bevel shear; flanging clamp; plate bending rolls, etc., etc. These are served by two light band travelers which run the full length of the bay.

Reaming, riveting, chipping and caulking are done by pneumatic tools, the outfit including Boyer holders-on and riveting hammers, Cleveland chipping hammers and Monarch air drills.

In addition to building the ordinary locomotive type of boiler, the Geo. White & Sons Co. make a similar boiler for burning straw, which has proved very popular in the Canadian West. In this boiler the fire-box, instead of being square, has the upper part of the flue sheet set back about 20 inches towards the rear end of the box, as may be seen in the sectional view on this page. The boiler thus has what the company term a double crown sheet, the lower sheet being seen at (A) and the upper at (B). Immediately inside of the fire door is fitted a dead plate which occupies the back end of the fire box, and from this straw grates extend to the front end. Draft dampers are so arranged that air can be admitted at either or both ends of the fire box as may be required. The straw is burned on the grates immediately beneath the lower crown sheet (A), from which baffle plates extend to within six inches of the rear end of the box. Passing around these baffle plates, the flame comes in contact with the upper

crown sheet (B) and then passes into the flues, which by reason of the peculiar formation of the fire box are twenty inches longer than in a square fire box of the same overall length. This gives the boiler a greatly increased heating surface, while its weight is increased very little and its size not at all.

The Blacksmith Shop.

This department, 63 x 100 ft., also presents a very orderly and neat appearance. bars, angles and other material be-

wheels are assembled. The rims are made from steel plate, and the spokes from steel bar securely riveted to rim and hub. The latter is a malleable casting of substantial design. The large "bull" gear wheel, by which motion is transmitted from the engine to the road wheels, is fitted on a turned journal and drives the road wheel by dogs fitting between the spring housings. This makes an efficient cushion for taking up shocks that would otherwise be transmitted to the gearing.

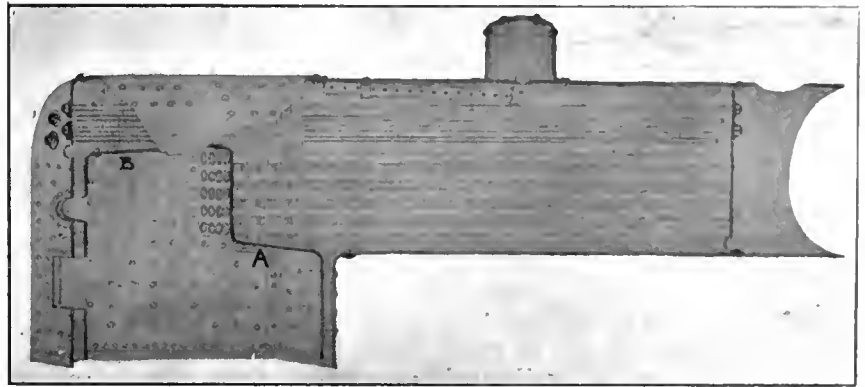

THE WHITE SPECIAL STRAW BURNING BOILER.

ing neatly stacked in such a way that they may be easily got at. There are five forges, two being specially adapted for heating rings and bar work generally. The work is of a light character, so that a single No. 7 Beaudry belt-driven power hammer answers all requirements. In the south-west corner of the shop is the air compressor—a Rand two-stage machine of 400 cubic feet capacity. This is belt-driven by a 65 H.P. A. C. Lancashire motor, and provides air for the boiler shop, assembling shop, foundry, etc.

The east bay of this department forms the wheel shop and here the heavy road

This department has a jib crane centrally placed to serve a large portion of the floor. There is also a hydraulic wheel press for pressing crank discs upon their shafts and for forcing in crank pins.

Assembling Department.

The assembling department measures 100 x 79 ft. and takes care of the erection of new work and also the repair of old engines. The east bay roof is carried by a double row of columns in order to support crane runways. This bay forms the erecting shop for new engines and three of its bays are equipped with overhead travelers running transversely across the shop. These travelers were built by Geo. Anderson & Co., Ltd., Montreal, and are each of 15 feet span and 4 tons capacity. Their longitudinal and cross-traversing motions are operated by hand from floor level, while the hoisting motion is by electric power.

In the west bay old engines are repaired and new engines tested in steam for which latter purpose there are four smoke jacks for carrying off the smoke and exhaust steam. For repair work there is a central jib crane for lifting cylinders, crank shafts, etc. When it is necessary to lift the boiler, the engine is run into the middle bay, where the 10-ton traveler can reach it.

After being steamed, the engines are painted, and then pass out into the yard outside. From thence they go to the finished store-house, being towed by a



INTERIOR OF BOILER SHOP.

traction engine which here serves the purpose of a yard "dinkey engine."

The Machine Shop.

The south leg of the building forms the stock room and machine shop. The former measures 100 x 63 ft. and is fitted up with the usual racks and shelves for the convenient accommodation of finished and semi-finished material. Here, too, is situated the Sheldon heating apparatus which warms the machine shop and the west leg of the building. The stock room is divided from the machine shop by a wall fitted with fire doors.

A view of one corner of the machine shop is seen on page 66. The floor area measures 100 x 142 ft., the width being divided into a centre bay of 25 ft. and two side bays of 37 ft. 6in.

The north bay is chiefly used for bench work, pipe work, and storage of material waiting to go to the erecting shop. The machine tool equipment is operated from two lines of shafting driven by motors. It is of the usual type met with in a shop of this description and includes a fine 36 x 36 in. x 12 ft. planer by John Stirk & Sons, Halifax, England. This was installed about 18 months ago, as was also a 52 inch boring mill by the Bausch Machine Tool Co.

Cylinders have the crosshead guide east integral with them and both are bored at the one setting on a McKechnie-Bertram lathe. One frequently meets with these old lathes still being used for accurate work in different parts of the country, and the fact speaks well for the careful workmanship originally put into them.

The Foundry.

The foundry building is the most recent addition to the plant and went into operation at the end of 1911. It forms the east leg of the main building and is 257 feet long by 75 feet wide, divided by a wall into two parts. The larger part forms the foundry proper and the smaller the eastings storage and cleaning de-

partment, and is carried on an overhead platform at the north end of the shop. The heated air is delivered to the foot of alternate columns by underground ducts, similarly to the other shops. Artificial lighting is by 250-watt tungsten lamps.

The foundry has two side bays 26 ft. 6 in. wide and a centre bay of 22 ft. There is a monitor roof the full width of



A VIEW IN THE ASSEMBLING DEPARTMENT.

partment. The foundry is at the north end of the building and is 174 ft. long by 75 ft. wide. It is of the same general style of construction as the boiler shop, erecting shop, etc., except that the columns are of heavy 6-inch, W.I. pipe, instead of timber. The heating apparatus here was also manufactured by Sheldons,

this centre bay with side windows which can be opened or closed from floor level. The cupola room is in the east bay and contains a 42-inch Calumet cupola of the double tuyere type. A comparatively soft blast is used (8 to 9 ozs.), since the cupola is of ample size for the needs of the foundry and never requires to be



INTERIOR VIEW OF FOUNDRY LOOKING SOUTH.
Note the overhead Mono-Rail Runway which here takes the place of a Traveling Crane.

forced. The blast is supplied by a No. 8 Sheldon Noiseless Fan.

The driving gears used on all the traction engines are made from a semi-steel mixture containing 25 per cent. of steel scrap. The daily cast averages 7 tons, including about 1 ton of semi-steel, which is always run off first. In melting the semi-steel, the coke bed is, of course, first made up and immediately on top of it is put a layer of $\frac{3}{8}$ -inch steel plate scrap. On top of this comes the pig iron and then the cast iron scrap and returns (sprues, etc.) The steel scrap, as above mentioned, constitutes 25 per cent. of the total charge.

No dry sand moulds are made, so that one small oven, for core drying, is sufficient for the needs of the shop. This is situated alongside the cupola room and is fired by coke in the usual way. The oven is fitted with shelves and in order to fully utilize all the available space there is a truck with several tiers of shelves, which can be run in on a narrow gauge track. A similar track along the east wall of the foundry, north of the cupola room, brings in pig, scrap and coke from the yard outside and delivers same to the charging platform elevator. South of the cupola room, the east bay is occupied by the core makers, while north of it, light floor moulding is done. The north end of the west bay is taken up by ten bench moulders, the rest of this bay being given over to the heavier floor work, for which purpose it is equipped with a 14 ft. jib crane. No very large castings are made, the heaviest weighing about 800 lbs. The machine moulding equipment includes two Farwell squeezers, two Osborne straight-draw machines and one Pridmore roll-over machine.

The middle bay is not used for moulding but forms a midway for the transfer of castings to the cleaning department and for the passage of ladles up and down the shop. It is equipped with an overhead mono-rail runway installed by W. D. Beath & Son, Ltd., Toronto. This runs the whole length of the foundry and cleaning room, with a switch into the tumbler room. The runway is indicated by dotted lines on the plan of the foundry—see page 66—and it will be noticed that it forms a loop in front of the cupola. By this means, ladles of molten metal up to 2 tons in weight are quickly transferred from the cupola to any part of the foundry. At the light moulding floor the metal is poured from the large ladle into hand ladles, and at the heavy floor the large ladle is transferred bodily to the jib crane. In this way the carrying of metal from the cupola to the various floors by hand is entirely eliminated.

The runway may be clearly seen in the half-tone illustration of the interior of the foundry. It has a capacity of 2 tons on each trolley and consists of a 10-inch I-beam. There are nine junction switches arranged in groups of three each, permitting a trolley coming from a branch line on to the main line to turn to right or left, and at the same time leave the main line intact. The junction switch on a "Beath" runway has no moving parts. The trolley is fitted with a guiding bar by means of which the operator can direct the course of the trolley to right or left at the switch, without the necessity of stopping. This feature is particularly valuable where one man following another wishes to switch to a different track. The trolleys are fitted with "New Departure" ball bearings and are of the bogie or swivel type, enabling them to travel round sharp curves with a minimum of friction.

The Cleaning Department.

At the south end of the foundry, and divided therefrom by a wall, is the cleaning room and finished castings storage. It measures 82 x 75 ft. and is singularly free from the dust and dirt usually associated with a cleaning department. This is accounted for in part by the fact that only the larger castings are cleaned here, the smaller ones being treated in two tumbling mills fitted with dust exhausters and located in a special department in the north-east corner of the shop. Here, too, are found the emery grinders, so that all dust is localised.

The south end of the cleaning room is fitted up with racks and shelves for finished castings which are here stored preparatory to going to the machine shop. A small space on the east side is set apart for a few pattern makers. The company have a very complete line of patterns on hand for their various lines, so that they have no need of a regular pattern shop at present.

Patterns are stored in a two storey concrete fire-proof building measuring 47 x 27 ft. The location of this may be seen on the plan.

Office Building, Etc.

This building is handsomely furnished in quarter oak, with separate offices for the heads of each department. The ground floor of the rear half of the building forms the shipping clerks department and also a show room where one of the firm's standard separators, with its sides removed to show the working parts, is always available for inspection. It is operated by belt from a motor. The upper floor forms a store room for finished repair parts, a large number of which are always on hand so that customers may be enabled to make good

an accident with a minimum of delay. There is also a small drawing office on this floor.

The officials of the company are:

George White, Sen.—President.
Arthur W. White—General Manager.
Fred. J. White—Sales Manager.
H. B. White—General Superintendent.
H. F. White—Assist. Superintendent.
E. A. White—Accountant.
George E. White—Western Manager.



OIL ENGINES FOR TRAINS—THE "PARAGON."

ELECTRICALLY-DRIVEN trains, deriving their power in the first instance from crude oil, and dispensing with overhead wires, third rails, and extensive power stations, may, says the "Standard," be seen in the near future in the London suburban service of one of the big railways. These trains are expected to run at a cost of 3 cents per train mile, as compared with the cost of 6 to 10 cents per mile on the existing steam system. The locomotive specially designed for this purpose will have a total weight (without fuel) of 35 tons, and will haul the customary suburban train at a maximum speed of 40 miles per hour. Apart from the economy in running cost, it is expected to reveal a great advantage over the suburban tank engine in rapid acceleration upon leaving a station. The engine by which this remarkable development is to be accomplished is stated to have a far greater efficiency than any oil engine yet constructed.

Silent in Operation.

In spite of the relatively high efficiency of the Diesel oil engine, one of the joint inventors of the "Paragon" is reported to have said there are several difficulties militating against the application of the former to railway work. The noise of the exhaust and the large quantity of water required for cooling purposes are prominent amongst these. The engine they have designed for use around London and also for a large rail car in the colonies will be almost silent in operation, and will require comparatively little water for cooling purposes. The exhaust, instead of discharging into the atmosphere at a high pressure and temperature, will leave the cylinders at almost atmospheric pressure. The heat, instead of escaping with the gases or boiling the water in the cylinder jackets, will be converted into energy. With the most efficient heavy-oil engines in use to-day, from 35 to 40 per cent. of the heat in the fuel is wasted in the cooling jacket and the exhaust. The "Paragon" engine will

show nearly 20 per cent. greater efficiency on this point alone.

Greater Efficiency Promised.

This greater efficiency, continued the inventor, is secured by expanding the exploded vapor to a greater degree than in the Diesel type of engine. By transforming the power thus obtained into electrical energy, and then driving the train by an electric motor, an efficiency far in excess of that obtainable by steam power is guaranteed. It will be possible, too, at first to run one of these oil-electric trains in amongst the existing train services and thereby obtain an actual comparison of efficiency and running cost. To the railway that favors oil-electric trains for long or short distances in preference to "electrification," there is no problem of reconstructing the telegraph services. In an oil-electric train the electrical circuit is so self-contained that no baneful effect is produced on the telegraph systems.



CANADIAN RAILWAY PROFITS.

IN an interesting table just compiled by Mr. J. L. Payne, Comptroller of Statistics for the Railways and Canals Department, and tabled in Parliament, it is shown that during the twelve months ending June 30, 1912, there were 2,953 additional miles of railway put in operation, with 1,738 miles more reported ready for operation, and 10,000 miles under construction. All told the railway mileage of Canada is now over 30,000, exclusive of sidings, double-tracking, etc.

Eliminating Government lines, the total capital liability of Canadian railways on June 30 last was:—Stocks, \$770,459,351; bonds, \$818,478,175, a total of \$1,588,937,526, or \$50,832 per mile. On this capital investment dividends were paid last year totalling \$31,164,791, equalling 4.04 per cent. on the total stock issue. The rapid growth in net earnings may be gauged from the fact that in 1907 dividends totalled only \$12,760,435.

The total federal, provincial and municipal cash aid now totals over \$208,000,000, while land grants total over 56,000,000 acres. Federal and provincial bond guarantees aggregate \$245,070,045, of which the Dominion's share is \$91,983,553. Alberta has pledged its credit to the extent of \$45,489,000; British Columbia, \$38,946,832; Saskatchewan, \$32,500,000; Manitoba, \$20,899,660, and Ontario, \$7,860,000. Cash aid to railways totalled \$5,892,818 for the twelve months, including \$4,994,416 to the Grand Trunk Pacific under the "implement" clause.

Traffic shows a record gain during the year. The number of passengers carried was 41,124,181, an increase of 4,026,463 over 1911. The number of tons

of freight hauled was 89,444,331, a gain of 9,560,049. The traffic increase is reflected in the gross earnings, which totalled \$219,403,753, a betterment of \$30,670,259, or a little over 16 per cent. In ten years the gross earnings of Canadian railways have more than doubled. Operating expenses last year amounted to \$150,736,540, or \$19,691,494 more than in 1911. Net earnings were \$68,677,213, an increase of \$10,978,504 over the preceding year. Net earnings per mile of line last year were \$2,570, as compared with \$2,272 in 1911.

Additional Gross Earnings.

The outside operations of Canadian railways in 1912 created additional gross earnings of \$21,221,775, and operating expenses aggregating \$15,333,618.

	1911.	1912.
Earnings per mile of line	\$7,430	\$8,210
Operating expenses per mile of line	5,159	5,639
Net earnings per mile of line	2,271	2,571
Freight earnings per train mile	2,494	2,376
Passenger earnings per train mile	1,348	1,390

Following were the sources of revenue and amounts for 1911 and 1912:

	1911.	1912.
Passengers	\$50,566,894	\$56,543,664
Mails	1,869,414	1,914,720
Express	4,674,135	5,294,388
Baggage, parlor cars, etc.	1,207,555	1,295,415
Freight	126,570,534	149,961,140
Station and train privileges	826,252	1,086,687
Telegraphs, rents, etc.	3,018,710	3,367,739

Total . . . \$188,733,494 \$219,403,753

Operating Expenses.

The distribution of operating expenses in 1912 was as follows:

	Amount.	P.C.
Way and structures	\$31,514,098	20.90
Equipment	29,811,510	19.78
Traffic expenses	5,293,700	3.51
Transportation	78,969,544	52.39
General expenses	5,137,688	3.42

The equipment reported in use on 30th June, with the additions for the year, was as follows:

	1911.	1912.
Locomotives	4,484	265
Cars in passenger service	4,946	433
Cars in freight service	140,918	13,760
Cars in company's service	10,466	888



A HIGH SPEED FILE.

MANUFACTURERS in Sheffield, England, are displaying marked activity and enterprise in producing files of high efficiency, and to an increas-

ing extent, users are buying such goods on the basis of the amount of work they do under mechanical tests instead of merely accepting the lowest tender. American competition in this important industry, it is claimed, was practically eliminated from the British market several years ago, and Sheffield makers have gone well ahead of their trans-Atlantic rivals in developing what is known as the "high-speed" file.

We have before us the report of a test by the Sheffield Testing Works, Ltd., of the high-speed "Lightning" file, which has lately been placed on the market by Loekwood Bros., Ltd., of Sheffield. According to this report, a 14-in. file, tested on both sides, made 120,000 strokes, and in 39 hours removed 78.80 inches of metal weighing 22 lb. from an inch-square bar. At the conclusion of this severe trial, the tool was reported to be "slightly worn." The makers claim the result of the test to represent the highest point of working efficiency ever attained by a file under similar condition. It may be of interest to state that the British Admiralty require the files they buy to make only 20,000 strokes and to remove six inches of material. The "Lightning" file, it is claimed, will do treble the amount of work of an ordinary file.



TOLL OF RAILWAYS.

ACCIDENTS in connection with the operation of Canadian railways in 1912, resulted in the killing of 568 persons and the injuring of 3,780. These totals represent an increase over 1911 of 73 in the number killed, and of 451 in the number injured. One passenger in every 872,855 was killed, and one in every 84,792 injured. The killed and injured from the movement of trains were divided by classes as follows:

	Killed.	Injured.
Passengers	47	485
Employes	215	1,606
Trespassers	235	193
Non-trespassers	48	120
Postal clerks and others	..	33

Contributory Causes.

The causes of death and injuries to passengers in 1912 were as follows:

	Killed.	Injured.
Collisions	18	73
Derailment	..	203
Parting of trains	..	4
Falling from trains	10	51
Jumping on or off	4	70
Struck at highways	4	2
Struck at stations	3	4
Struck at other points	1	1
Other causes	7	77

There were 110 persons killed on electric railways, an increase of 8, and 3,128 injured, as compared with 2,670 in 1911.

TAPER-SHANK DRIFT.

By A. B. C.

DRIVING out a drill, a butt-mill or any tool having a tapered shank, from the spindle of a heavy-pattern machine, such as a radial drill or boring mill, by means of a "drift," requires several hard blows of a hammer on the end of the drift before the tool will

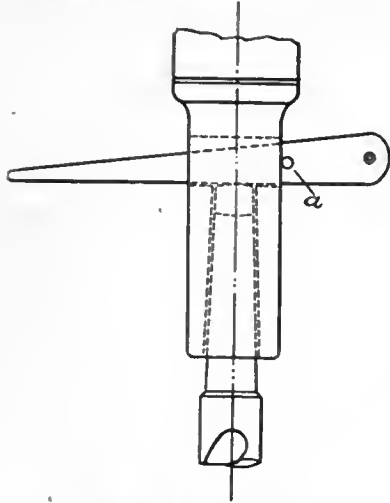

TAPER SHANK DRIFT.

case up, and when the tool gives way, the drift becomes tightly wedged in the broach of the spindle. To remove the drift, the workman must reach around the other side of the spindle and hammer the drift backwards. This is very inconvenient, since his two hands are occupied, one holding on to the tool and the other holding the hammer. The drift, when struck even lightly, generally flies a considerable distance from him, and to prevent this, the accompanying sketch shows a brasspin (a) about 3-16 in. dia., placed in the drift, which secures the latter against sticking in the broach, and makes it easy of removal by hand.



BORING A 4-FOOT DRUM ON A 12-INCH LATHE.

By G. Barrett.

THE following description shows how we rebores and bushes on a 12-inch lathe a hoisting engine drum 4 feet in

diameter. The first operation, of course, was to pack up the headstock sufficiently to swing the work. One end of the drum was then bored to suit the new bushing. We next searched the scrap heap and took from it a cast iron plate about 12 inches in diameter by 1 inch thick. This was clamped to the lathe face plate by 3/4-inch cap screws. The

made a good steady rest for the drum and took the strain of the overhang off the lathe spindle. The outer end of the drum having been bored, the new bushings (not shown) were driven in, and to our delight the drum shaft slipped easily through into its place, showing that the two bushings were in perfect alignment.

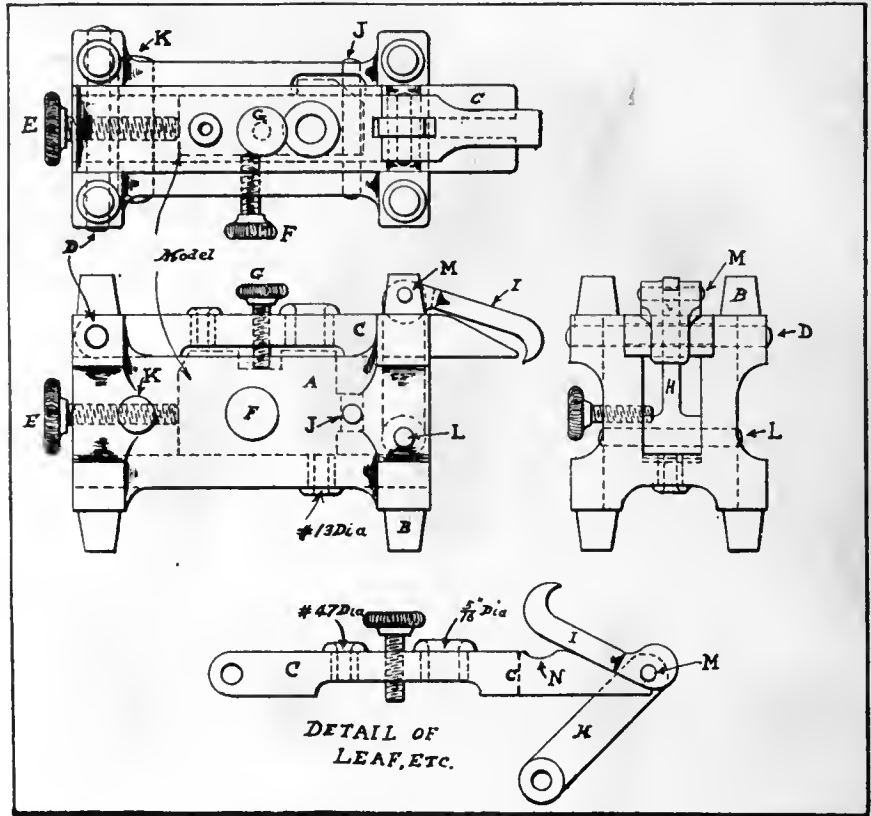

A NEW CAM DEVICE ON DRILL JIG.

plate is shown in the cut at (A). As will be noticed a boss was turned up at its centre, of a diameter to fit the end of the drum already bored. This boss was 3/8-inch high. The drum was easily clamped to the face plate by means of the arms at the end as shown at (C).

Next a piece of mild steel plate, 4x1 inches, was bent into the shape shown at (B) and bolted to the lathe bed. This

A NEW CAM DEVICE ON A DRILL JIG.

By A. L. Monrad.

THE fact that the work to be drilled in this jig was very short and broad made advisable a construction that would eliminate the use of a long handle for operating the clamping leaf. The design herewith illustrated has proved entirely satisfactory and makes a short, compact jig.

A machinery steel block was worked out as shown at (A), large rounded inside corner being provided in order to eliminate all spring of the side walls during the operation. Hardened and drawn tool steel legs (B) were screwed in on top and bottom as shown, their bearing faces being then ground up perfectly square and parallel with one another. These faces formed a finished surface, with which the inside of the jig was finished parallel.

The clamping leaf (C) is fulcrumed on a 5-16 inch pin (D). This pin is a driving fit in the steel frame, but a turning fit in the leaf, to allow the lat-

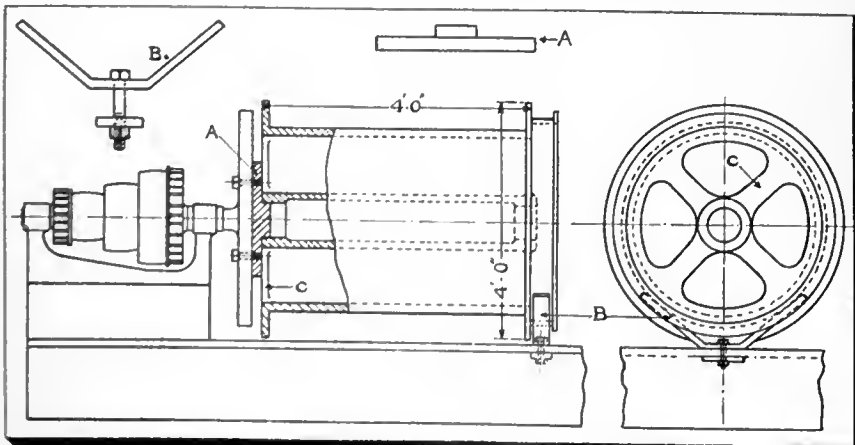

BORING A 4 FT. DRUM ON A 12-INCH LATHE.

ter to be swung up out of the way when reaming the front, or 5-16 inch hole, in the work. The hole in the leaf for the fulcrum pin must, therefore, be absolutely square with the inside of the jig. The knurled screws (E), (F) and (G) keep the work in position against the stop pin (J) and against the bottom and one side of the jig. The pin (K) forms a nut for the screw (E).

A swinging link (H) is held with a pin (L) through the jig frame. At the other end of this link is located the cam (I). This swings on an eccentric pin (M), and, when seated, secures the clamping leaf against the two shoulders on the jig frame. The leaf has a slot in it, as seen in plan, to accommodate the link (H), and on each side of the slot it is milled out for the cam, as shown at (N). To disengage the work, the cam is turned and slides down the inclined nose of the clamping leaf as seen in the detail.

TWO HANDY HOME-MADE TOOLS.

By Avery E. Granville.

A SHORT time ago I saw a workman in a roundhouse using the tools shown in the accompanying halftone. He had made them himself. The upper one is a file handle, or rather file holder, made to clamp to the body of the file so that it may be used like a plane, a great advantage on some kinds of work. The handle is made of cast brass, two lugs being cast on one side of the bottom for the edge of the file to butt against, while the file is gripped by a nut-lug opposite these two, operated by a thumbscrew as shown.

The second tool shown is an inside caliper. The points are made of two pieces of drill rod, which are run



TWO HANDY HOME-MADE TOOLS.

through two slots in a bent piece of flat spring. By pressing on the outer ends of this spring the rods are released and may be set as desired, but with the spring on tension it takes considerable force to move the points. The beauty of this kind of an inside caliper for

rough work, is that longer rods are easily made for any ordinary job, the same spring serving for any number of rods.

AN UNUSUAL JOB FOR A LATHE.

By F. Cotton.

THE photo-illustration shows how on one occasion we faced up the outlet flange of a large blower frame casting. Not having a horizontal boring mill

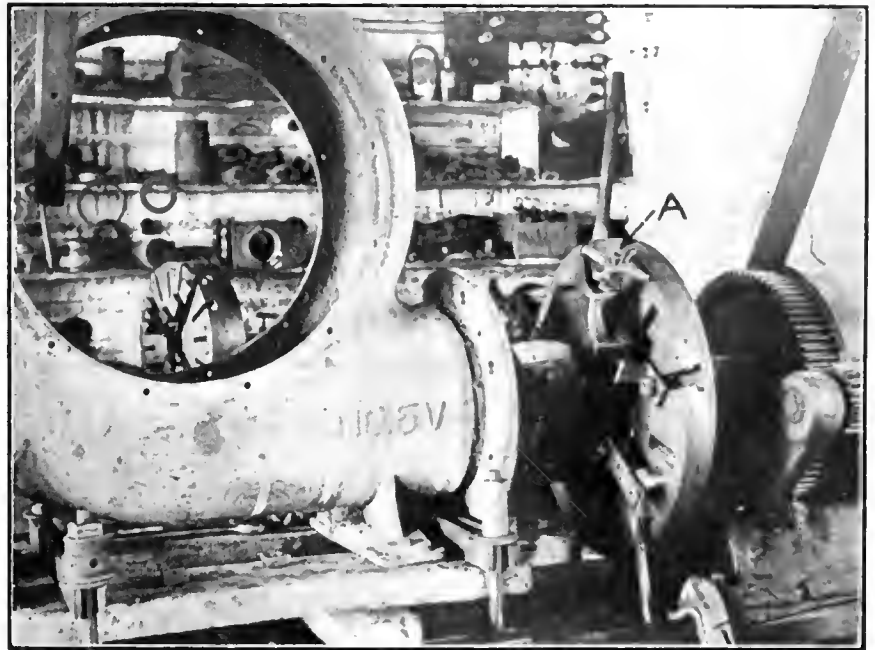

AN UNUSUAL JOB FOR A LATHE.

available, we did the job on a lathe, with very successful results. The compound slide rest was removed from the carriage and bolted to the lathe face plate, as shown. The tool holder was removed from it and four 1½-inch studs 2½ inches long were tapped in and fitted with 2½ in. x 1½ in. straps to hold the tool. The latter was made of 1¼ in. x 7/8 in. self-hardening steel, bent through a right angle. The feed was obtained from the star wheel (A), which was operated by a bolt fastened to the lathe bed by a clamp. The blower frame was then strapped to the carriage, the resulting job being all that could be desired.

THE DOTY MARINE ENGINE & BOILER CO., GODERICH.

THIS company was incorporated last fall to take over the business of the Doty Engine Works Co., Ltd., and have now put the business on a thoroughly sound basis.

The new company is composed of the following gentlemen: John W. Doty, of New York City, President; Fred W. Doty, Vice-President and Manager; Jos.

G. Reinhardt, Treasurer, Chief Draughtsman and Mechanical Engineer; William Proudfoot, K.C., M.P.P., Secretary.

The re-organization of the business has been worked out most satisfactorily, placing the company in a position to handle the increased trade coming their way. For some years this plant has been building high-class hoisting and marine engines, and is about to commence the manufacture of well-known types of steam boilers.

The new boiler shop completed early in 1912 has been fully equipped with modern tools and is now turning out Scotch boilers up to 8 feet diameter by 10 feet long. The equipment includes 5-ft. gap riveter; 26-ft. plate edge planer; 9-ft bending rolls; combined punch, shear and angle cutter; 60-in. radial drill; etc., etc. There is also a full assortment of small tools, pneumatic hammers, etc. Air is supplied by a belt-driven compressor. Extensive improvements are also being made in the foundry, and when these are completed, the company contemplate important changes in other departments of the works.

About 70 men are now employed, and it is said that orders on hand and in view are most encouraging.

The General Fire Extinguishing Co. of Providence, R.I., have recently completed handsome offices, warehouse and garage at 1200 Dundas Street, Toronto, and are now occupying same. This office will look after all business developing in Ontario and the middle west. Eastern business is handled from the Montreal office and Vancouver looks after the far west.

TITANIUM AS A CLEANSING MEDIUM IN STEEL MANUFACTURE.

By Frank Walker.

FOR some considerable time it has been a recognized fact that the presence of oxygen and nitrogen in steel, even in very small quantities, has a most injurious effect, decreasing the tensile strength and general wearing qualities to a marked degree. Owing to their gaseous nature, a correct analysis of steel for these elements has been most difficult to obtain. But some recent investigations, conducted with extreme care and minuteness by Sheffield and Pittsburgh metallurgists have shown that both these gases are present in open-hearth, Bessemer and crucible steels to an extent hitherto unsuspected, and the combinations which they form with other elements present, have a wide influence on the quality of the steels in question.

Effect of Nitrogen and Oxygen.

An analysis of twenty-four samples of steel showed the oxygen content to range from .021 to .046 per cent., and that of nitrogen from .01 to .062 per cent. These quantities may seem so small as to be not worth considering, but it has been conclusively proved that the presence of .030 per cent. of nitrogen in steel containing .50 per cent. of carbon causes it to become absolutely brittle, and that the presence of .030 per cent. of oxygen corresponded to .135 per cent. of ferrous-oxide, an amount quite sufficient to have a most material effect upon its resistance to stresses.

Scavenging Agents.

The de-oxidation of steel has, until recently, been accomplished by the addition of manganese, but not with perfect success, the nitrogen content remaining unaffected by the addition of either manganese or silicon. Steel-makers have recognized the fact that resource must be had to some element that possesses an affinity for both of these gases, and most successful experiments have been recently carried out with titanium, an element belonging to the same chemical group as silicon. These experiments have proved that, used in conjunction with manganese, titanium is by far the best scavenging medium yet discovered. It has a very strong affinity for both oxygen and nitrogen, and presents the only undisputed example of combustion of an element in nitrogen. It has also been found to re-act upon the sulphur content of the steel, and while not entirely eliminating it, reduces its percentage greatly by carrying a portion of it off into the slag in the form of a sulphide or sulpho-cyanide of titanium. It has, therefore, a most beneficial effect upon

the three most refractory elements with which steel-makers have to contend.

Titanium in Nature.

Titanium occurs in nature in the form of a di-oxide (TiO_2) principally in conjunction with iron, but in its natural state is extremely difficult to control. It has, therefore, been found necessary for commercial purposes to separate it from the ore by electrical treatment and manufacture it into ferro-titanium, containing 12.5 to 15.0 per cent. of titanium, 6.0 per cent. of carbon, and the balance iron.

Adding the Ferro-Titanium.

This combination, if added to the steel in the manner to be described, enters into almost instantaneous solution, and the mixing is accompanied by a most interesting and peculiar phenomenon. It has been found that the best way to add the ferro-titanium is while the steel is being run from the furnace or converter to the ladle, and after the ferro-manganese has been added. Titanium is much lighter than iron, having a specific gravity of 4.87 against 7.86 for iron, and therefore should not be added too near the top of the ladle, but shovelled in gradually as it fills.

It is here that the phenomenon spoken of occurs. The titanium at once commences to attack the oxygen and nitrogen in the steel and carries them off into the slag as oxides and nitrides of titanium. This chemical work is accompanied by a great increase in temperature, and though the steel must be held in the ladle for from 12 to 15 minutes to allow the scavenging to be accomplished, at the end of this time the steel will be found to be hotter than when first tapped and in a better condition for teeming.

In conducting the experiments it was found most difficult to persuade the workmen to hold the steel for such a length of time, as such a procedure is directly opposed to all usual practice; and under ordinary circumstances the metal would become chilled in a much shorter period. But in one instance the ladle was held for 20 minutes and then teemed most successfully.

In all the experiments it was noticed that the amount of slag lifted was much greater than that from untreated steel, and also that the steel when poured subsided quietly in the moulds without boiling and the ingots when stripped were almost free from pipes.

Amount of Titanium Necessary.

As the melting point of titanium is much higher than that of iron, it is found difficult to add it to the charge in large percentages, 1.0 per cent. being found to be about the limit. But in actual practice for commercial steels, half

this amount is sufficient, and of this almost all will pass into the slag in combination with the impurities it removes, leaving but a trace of titanium in the resulting steel.

Results Attained.

Its beneficial effect is, nevertheless, most marked as the following tests show:

A bar of open-hearth steel containing 0.25 per cent. carbon, 0.64 per cent. manganese, 0.425 per cent. silicon, 0.04 per cent. phosphorus, and 0.035 per cent. sulphur, was subjected to a rotary vibrational test in a White-Souther machine. It was loaded to a fibre stress of 38,870 lbs. per sq. in., and broke when it had made 2,660,000 revolutions. This same steel was then treated with 0.5 per cent. of titanium, and a similar bar was then tested. This bar withstood 4,052,200 revolutions at the same fibre-stress. The stress was then increased to 40,600 lbs., and the bar withstood 10,800,000 additional revolutions without fracture.

Another steel containing 0.25 carbon, 0.30 manganese, 0.40 silicon, 0.04 phosphorus, and 0.03 sulphur, gave considerable trouble by developing edge and corner cracks, while being rolled or forged. This steel was then treated with 0.30 per cent. of titanium and gave no further trouble, working down smoothly and evenly without flaws, and retaining its working heat for a much longer period. This slower cooling by radiation is a marked characteristic of all titanium treated steels.

NEW ELECTRIC LOCOMOTIVE.

A GERMAN contemporary gives a description of a new type of locomotive, built by Brown, Boveri and Co., for the Chemin de fer du Midi. The pulleys on the spindles of the two motors are connected together by means of a coupling rod, and are each similarly connected by coupling rods to a pulley disc, carried on the driving wheel. In this way a triangular system of coupling rods is built up, and the method has been found to give good results in practice, besides reducing the weight and cost of the locomotive.

The author shows that if the two motors have the same torque there is no stress in the rod connecting them together; he therefore suggests that this rod might be omitted. The motors may therefore be connected to the driving wheel by two cranks, which form with one another an angle rather greater than a right angle. On the triangular system, the angle between the cranks is about 60 deg. The author's system has the further advantage that the precise adjustment of the positions of the various spindles is unnecessary.

DEVELOPMENTS IN MACHINERY

A Record of New and Improved Machinery Tending Towards Higher Quality and Economical Production in the Machine Shop, Blacksmith Shop or Planing Mill.

A NEW SHAPER.

THE new 20-inch back-gear crank shaper illustrated herewith is a recent development of the R. McDougall Co., Ltd., Galt, Ont., for whom the Canadian Fairbanks-Morse Co. are sales agents. The machine embodies the best features of all machines that have hith-

to the Northwest Steel Co., Portland, Oregon, by the Vulcan Engineering Sales Co., Chicago:—

This is the well-known Q. & C. machine, later known as the Q.M.S. saw. The great change in design of the present machines over those that were first put on the market over twenty-five years

an additional factor of safety, should the blade become stuck in the work. The machines are mounted on a circular base, which permits cutting long pieces of material from any angle in the shop. They are, therefore, very desirable in a shop having limited room. The milling head is quickly and easily removed, and replaced by a saw blade, while the side table which is adjustable laterally carries an upper side table when the milling head is not in use.

The feed is of the adjustable, variable friction type, changeable at all times from $\frac{1}{4}$ to 1 inch per minute. The sprocket arbor, driving the milling head and saw blade from the periphery, is adjustable forward, to allow for 5 inches wear on the diameter of saw blade, this doing away with additional or larger sprockets where blades have been re-cut. The saw arbor is adjustable to take up any possible wear. Suitable clamps are furnished for various styles of work, and a (V) block cast in the end of upper side table permits of quick clamping of rounds or squares. Such a combination provides two machines in one, and at a low investment cost. The cut shows a machine carrying a $31\frac{1}{4}$ inch diameter saw blade, or a milling head of $28\frac{3}{4}$ inches diameter of cutters over tools. The saw blade carriage has a travel of 36 inches, and the saw blade runs at about 28 ft. per minute. The machine has capacity for 12 inch rounds, $10\frac{3}{4}$ inch squares and 24 inch I beams.

On the "Bryan" or periphery type of saw, the blade is driven by a sprocket engaging the back of saw teeth. This method of drive is an important advantage

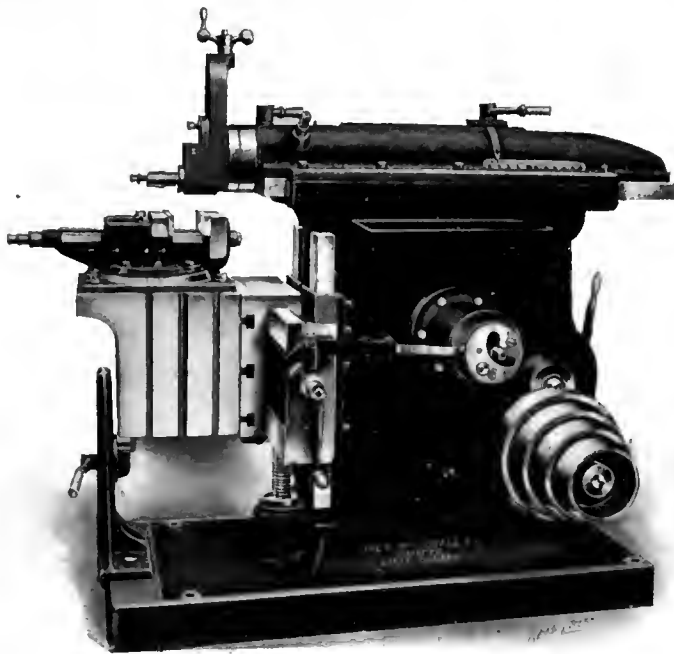

NEW McDOUGALL SHAPER.

erto been placed upon the market, while at the same time non-essential points have been carefully eliminated. The tool head has a vertical travel of 8 inches and a maximum length of stroke of 21 inches. Eight cutting speeds are provided. The table is of box form with Tee slots on top and sides cut from the solid. A Vee slot on one side serves to hold round stock in an upright position. The table has 22 inches of cross traverse and 14 inches of vertical travel. It is supported at the front by an adjustable sliding rest bolted to the base of the machine. The column is well braced internally, and ample opening under the ram is provided for keyseating or other long work.

A powerful vise is provided, fitted with steel-faced jaws and swivelling base.



COMBINATION SAW AND ROTARY PLANER.

THE accompanying text and illustration refer to the 4-B combination saw and rotary planer, recently supplied

ago, will be noticed by many who are still using some of the earliest machines.

The Q.M.S. machines when arranged for motor drive are now connected by belt to motor, instead of being direct connected by gear and pinion. This is

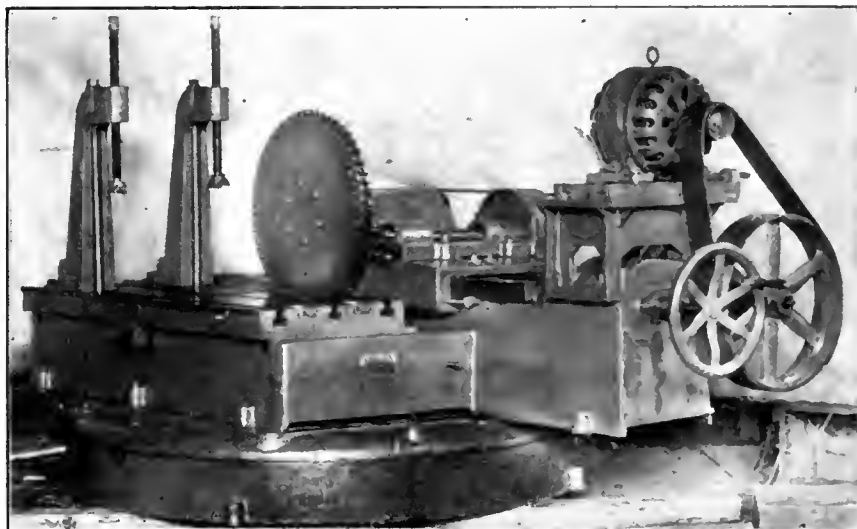

B COMBINATION SAW AND ROTARY PLANER.

age, in that a much larger diameter of the saw blade is available for cutting than when the same size blade is motor driven. On the arbor driven blade, about one-third of the diameter is occupied by driving collars. The teeth of the "Bryan" blade are of coarse pitch, and afford more room for chips than is possible in a fine tooth arbor driven blade. The adjustable friction feed can be changed when the machine is in operation, and is powerful and continuous in action through its entire range. Motion is transmitted to the feed screw through a clutch, which can be disengaged, permitting adjustment of carriage to work by hand. The machine is fitted with an adjustable stop, provided to stop carriage at any desired point of travel.



FLOOR TYPE BORING, MILLING, TAPPING AND DRILLING MACHINE.

THE text and illustrations refer to the boring, milling, tapping and drilling machines designed and built by the Rochester Boring Machine Co., Rochester, N.Y.

They have a wide range of capacity and adaptability, and combine in one unit in a minimum of space occupied, the range and capacity of several individual machines. Large, small or irregular shaped work can be machined to practically equal advantage, and single pieces can be finished rapidly, with economy almost equal to work in quantities. Boring, milling, drilling, tapping, splining, oil grooving, and rotary planing can all be done at one setting, and with swiveling table, the different sides of work can be finished complete. The precision construction, which is a feature, insures accuracy, and the mechanical features embodying quick and easy changes, conveniently obtainable, give maximum production.

The motor is mounted on top of column, free from dirt and chips, and drives, through rawhide gearing, the vertical shaft which transmits power to driving mechanism enclosed in saddle. By this arrangement, which eliminates many gears and shafts, a very high efficiency of power transmission is obtained, consequently much smaller motors can be used. Constant speed machines, either direct or alternating current may be used.

The Saddle is of box type construction, strongly ribbed, and is built as a complete unit. It is counterbalanced by weight and so constructed that the entire operating mechanism is readily accessible. The levers and handwheels for the various changes of speeds, feeds and traverses are all so arranged as to be unusually convenient for the operator. Lev-

er for starting, stopping, and reversing the machine is also located on the saddle, and the machine is controlled by this lever without stopping main drive. Hand adjustments and reversible power feeds are provided for milling, also power rapid traverse for quickly bringing to any desired position. Automatic safety stops are fitted at extreme positions to prevent accidents.

The Column is of very heavy construction with long and wide base. It is side braced and so designed as to give the utmost rigidity in all directions. It is adjustable along the bed by hand or power. Reversible power feeds are provided for milling, also power rapid traverse for quickly bringing to any desired position. It is conveniently arranged with binders for quickly clamping in any location when desired.

The Spindle is made of the best quality of hammered crucible steel of high carbon. It is rough-turned and season-

driven by two large spline keys, fitted into steel sleeves on which driving gear is mounted. This sleeve is journaled in independent bearings and clearance is provided between the sleeve and spindle to eliminate any possible vibration from driving gears. The spindle can be furnished any desired length and by means of concentric screw feed its full traverse is obtained without resetting, regardless of length.

The Concentric Screw Feed.—An original and exclusive feature of these machines permits continuous feed for any length—and is very powerful. It is more accurate, more mechanical, and much more sensitive than the old-style feed and eliminates the usual heavy and cumbersome strongback at the end of saddle. The usual construction, with rack and pinion feed, permits only a limited amount of feed, nearly all machines being arranged so the rack or gear has to be discontinued and drawn back to take

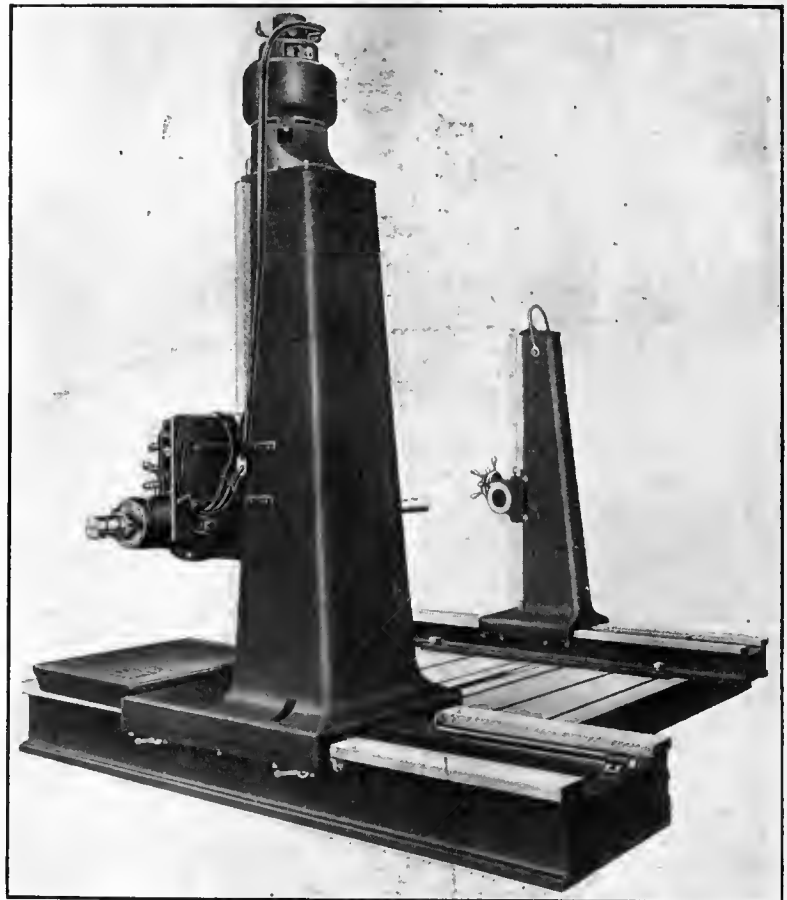

FLOOR TYPE BORING, MILLING, TAPPING AND DRILLING MACHINE.

ed before using; when finished it is ground to size on dead centres, and its alignment is correct. It is journaled in long taper bearings of phosphor bronze adjustable from the outside, provided with felt wipers, and located far apart at each end of the saddle, giving very rigid support. This is made possible by the feed and drive being applied central between the bearings. Spindle is

held on the bar. On large machines the strongback and connected mechanism becomes so large and heavy as to require extra counterbalancing. The tendency of a counterweight so applied is to pull the bar out of alignment if overbalanced. If the strongback is not balanced or underbalanced, the tendency is to sag to the extent permitted by the play in the sliding surfaces. Wear or loose-

ness in strongback clamping mechanism is reflected at the other or cutting end of spindle. This and also the side pressure to spindle, with rack and pinion feed, is entirely overcome, by the concentric screw feed.

The Method of Feeding is through a long bronze nut engaging a square thread in spindle. The nut comes in contact with sides of thread only and end thrust in either direction is taken direct on ball bearings of large diameter. Instead of the usual line contact, between the tooth of the gear and rack, with the old method, it will be seen that the square thread in nut, engaged for its full length with thread in spindle, provides a very long bearing, and as the two rotate together, the possibility of wear is very remote. The nut rotates at the same speed as spindle when the feed is disengaged. When feed is applied, the nut is rotated faster than spindle, according to which feed change gear is engaged, or slower than the spindle, if feed is reversed. This differential speed between the nut and spindle gives feed in either direction. Through positive planetary gearing, the bar is controlled by hand wheel, whether at rest or running. End thrust for milling is taken direct in the saddle, with bronze thrust bearing, independent of end thrust for boring.

A Wide Range of Feeds and Speeds is provided to meet all usual requirements. Vertical milling feeds are provided for the saddle, and horizontal milling feeds for the column independent of the boring feeds. All feeds are per revolution of spindle, and are the same for every part to which applied. They are all reversible, and any desired change can be instantly obtained. No

two feeds or speeds can be engaged together at the same time. Range of speeds can be readily changed to meet special requirements, giving faster or slower speeds of the same relative ratio.

A Power Rapid Traverse, independent of the feeds, is furnished for the saddle, column and spindle. No two traverses

can be engaged together. Power rapid traverse and the feeds cannot be engaged together, and automatic limit stops are provided for every traverse in every direction.

Safety Devices.—Friction clutches are used in the vertical high speed shaft and also for engaging power feeds. While these are positive up to their designed capacity, they provide yielding points when properly adjusted to prevent mechanism being damaged, otherwise all feeds are positive.

Automatic Safety Knockouts or Stops are provided for the saddle, column and spindle at extreme positions, insuring protection against accidents or damage.

No two feeds, or speeds can be engaged together, neither can power rapid traverse in different directions be thrown in, nor engaged till feeds are disengaged.

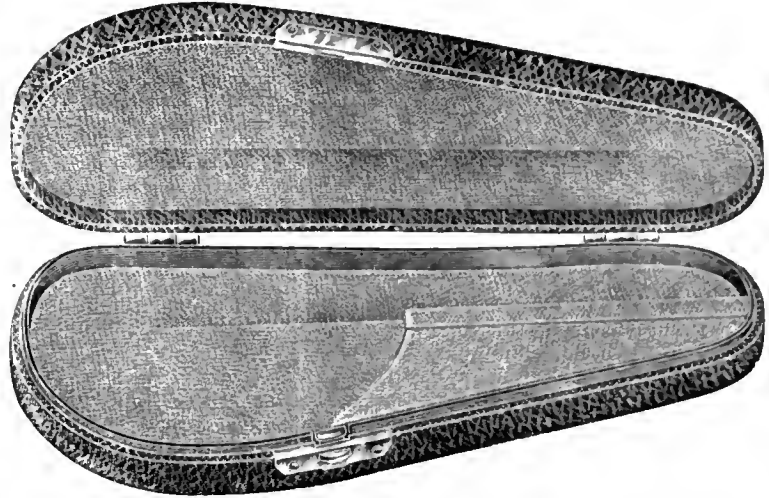

SLOCOMB MICROMETER CASE.

All gears and moving parts are enclosed and fully protected. A self-oiling system provides lubrication for the driving and feeding mechanism of the machine.



SLOCOMB MICROMETER CASE.

AN improved form of micrometer case has recently been brought out by the J. T. Slocomb Co., Providence, R.I. the well-known makers of micrometers and small tools.

As may be seen from the accompanying illustration, the new case is shaped somewhat after the model of a smoker's pipe case, but is free from the fault, often found in previous micrometer cases, of being too bulky to be conveniently carried in the pocket. The maximum dimensions of the case under review are only $5\frac{1}{4} \times 2\frac{1}{4} \times \frac{7}{8}$ inches—a very handy size. In other respects it differs but little from previous types, being covered with morocco leather and lined with velvet.



U.S.A. FREE ENGINEERING IMPORTS.

THE announcement that engines and other main auxiliary machinery of ships would be imported free under the Panama Canal Law having called forth vigorous protests from the shipbuilding interests, the Treasury Department of the U.S.A., states that only materials for the construction of machinery will be entitled to this privilege.

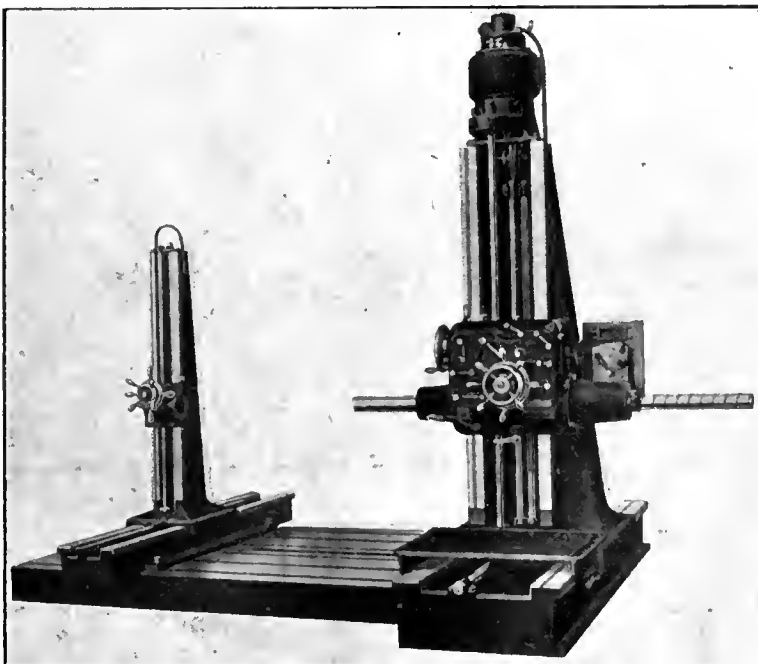

FLOOR TYPE BORING, MILLING, TAPPING AND DRILLING MACHINE.

ACME EXPANDING REAMER.

HEREWITH is illustrated the "Acme" expanding reamer lately brought out by the Schellenbach-Hunt Tool Co., Cincinnati, Ohio.

The body is of steel while the blades are of high-speed steel. These reamers are made in a large number of sizes with the expansion varying from 0.040-in. to 0.125-in. The expanding feature is intended to maintain the initial size of the reamer, and not to ream under-size or oversize holes. The blades expand their entire length, but from the

Another feature of the Premier die stock is the absence of the usual leader screw, the function of which is in this tool performed by the dies themselves. The latter are of a special patented form made in two steps. The first set of teeth start the thread and draw the die stock forward on the pipe, while the second set cut the full thread, the taper being obtained by the automatically expanding movement given the dies as they advance on the pipe. The absence of a leader screw enables the die stock to be made much shorter than usual, so that

sense of a leader screw, which would, of course, render impossible the threading of any screw differing in pitch from the leader.

The Premier die stock is well designed and strongly made. All parts are of steel, including the body, which is a steel casting. The use of this material enables a considerable amount of metal to be omitted around the circumference of the body, thus reducing weight and greatly facilitating the oiling of the dies. The automatic throw-off can be quickly removed when it is desired to

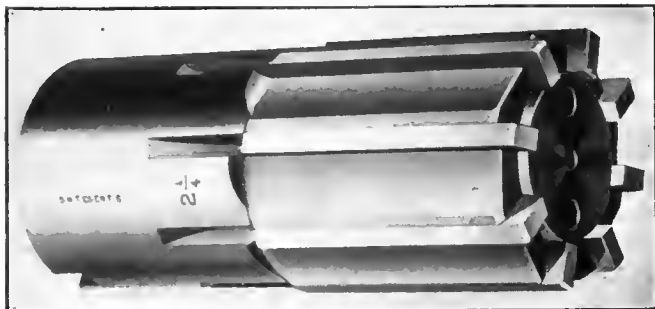

ACME EXPANDING REAMER.

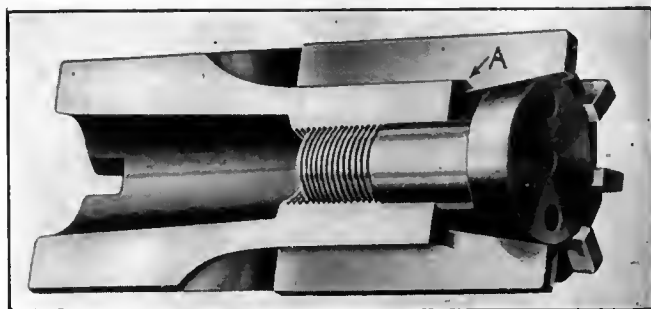

SECTION OF ACME REAMER.

form of construction the greatest expansion is at the outer end where the wear is greatest. The blades extend beyond the body of the reamer and beyond the expanding bolt, thus enabling the tool to ream square to the end of a blind hole or to the face of a lathe chuck. Blades are unevenly spaced and are made a tight frictional fit in the body. They cannot be forced back from the set position by end pressure, owing to the shoulder on their under-side abutting squarely against the face of the counter-bored wall as shown at (A) in Fig. 2. The design of the bodies leaves ample chip space and the blades are made interchangeable, enabling them to be quickly replaced from stock.

it is possible to thread a nipple 5½ inches long without the use of a nipple holder.

The centering device is very simple. It consists of a scroll cam, without locks, which operates three jaws that guide the die stock on the pipe. No loose bushings are used. The stock, with one set of dies, will thread pipe 1 inch to 2 inches in diameter, either right or left hand thread. This is accomplished by having the dies chased for R.H. thread at one end and

cut straight and running lock nut threads.



NEW SQUARE CAN DOUBLE SEAMER.

THE new automatic double seamer shown, has recently been designed and built by the E. W. Bliss Co., Brooklyn, N.Y. It is adapted for square, oval and oblong work, handling cans from ¾ to 5½ inches across corners from 1

A NEW CANADIAN DIE STOCK.

THE Borden-Canadian Company, Toronto, report a gratifying increase of business during 1912, their shop having been taxed to its utmost capacity. The company have within the past six weeks put upon the market a new die stock of their own design, which is meeting with a very favorable reception. This has been named the "Premier," and is of the automatic release type; so that as soon as the dies have advanced sufficiently far on to the pipe to complete a standard (Briggs) length of thread, they release themselves from the work and the tool is removed without the necessity of running it back over the threads. Much valuable time is thus saved and all risk of damage to the dies or thread is entirely avoided.

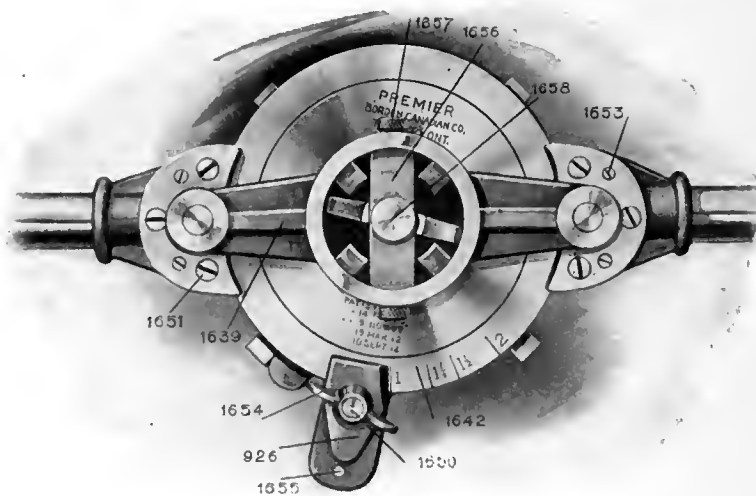

BORDEN-CANADIAN CO. NEW "PREMIER" DIE STOCK.

for L.H. thread at the other, and reversing them as required. By the use of one extra set of dies, the same stock will thread any pipe from ½ inch to 2 inches inclusive; while by the use of special dies, bolts, etc., may be threaded. This is one of the advantages of the ab-

to 10 inches in height. The rate of production depends somewhat on the size of the can and expertness of operator, varying from 12,000 to 20,000 ends in 10 hours. The machine is driven by an automatic friction clutch encased in the two step driving cone. A hand brake

arranged on the end of the driving shaft automatically engages and relieves after the work is done, and insures the spindle stopping in exactly the same position after every cycle. It will be noted that the lower spindle drive is positive, starting and stopping in unison with the upper spindle. This insures a perfectly straight body after double seaming.



NEW SQUARE DOUBLE CAN SEAMER.

All movements are automatic, leaving the operator nothing to do but place the can on the chuck and depress the treadle, which causes the lower spindle to rise and engages the clutch, starting the driving shaft connected to the chuck spindle by bevel gears, also bringing into action the double seaming rolls. The can is automatically revolved the requisite number of times, the double seamer rolls, after going through their motions, are automatically retired, the clutch is automatically disengaged, the chuck stopped, the lower plate dropped and the can released. The weight of the machine is 1,100 lbs.



TEN SPINDLE SEMI-AUTOMATIC NUT TAPPING MACHINE.

THE National Machinery Co., Tiffin, Ohio, originators of modern bolt and nut forging machinery have perfected and placed upon the market a new 1½ inch Ten Spindle Semi-Automatic Nut Tapping Machine which is shown in our illustration. This tapper is on the same general lines as the 1 inch Six-Spindle Semi-Automatic Machine which was illustrated in these columns previously; although the present tapper embodies improvements, being now equipped with a rapid change gear box which enables changes to be effected in the revolutions of the tapping spindles, for raising and lowering, to cor-

respond to the number of threads on the tap being used. Previously, these changes were effected by removal and substitution of gears, which consumed considerable time, and militated against frequent change. With this rapid gear change box, the spindle revolutions can be altered by merely shifting a hand lever, and this, while the machine is running. The ease with which changes can be effected prompts the operator to reduce the spindle revolutions as the taps are ground and the cutting teeth reduced in number, so that there is little or no idle tapping time—taps running free in the nut after it is tapped.

In this semi-automatic type of tapper, the spindles are raised and lowered by cams. Through this automatic spindle movement, the machine "sets the pace" for the operator, and the operator is relieved entirely from treading, as on the "foot lever" type of tapper; consequently he is not subjected to the attendant fatigue, and can devote his entire energy to feeding. Exhaustive trials have demonstrated that operators have no trouble meeting the uniform pace set by the machine throughout a working day, and that on this machine it is possible to secure large outputs.

The raising and lowering of the spindles by cams also tends to prolong the life of the taps. In foot-lever tappers it frequently occurs that the operator, through fatigue or negligence, allows

the spindle to drop, causing the tap to jam in the nut and bind, and frequently twist off or strip the teeth. This is overcome in the semi-automatic design, as the spindle descends gradually, and the tap is not subjected to sudden and excessive torsional strains.

The cams which raise and lower the spindles have three steps, and by shifting the cam shaft, the resting time of the spindles when raised can be altered to meet the needs of the operator for feeding. The spindles in this design are close together—which is a decided advantage, as it facilitates feeding, and enables the operator to successfully handle ten spindles without covering much floor space. The machine has sufficient range and power to tap two nuts of the smaller sizes on all spindles simultaneously, hence enabling outputs to be still further increased.

The nut holders on these machines are of novel and simple design. The nut guides are chilled plates of wedge shape, held in position by toe clamps. The guides are backed by stationary lugs of corresponding angle on the feed table, thus making the guides extremely rigid, and insuring, also, parallel positions of the guide faces, as they are clamped rigidly against the stationary lugs. The guides have no tendency to shift or spring, and there is, therefore, freedom from binding of the nuts when feeding. Openings are provided in the

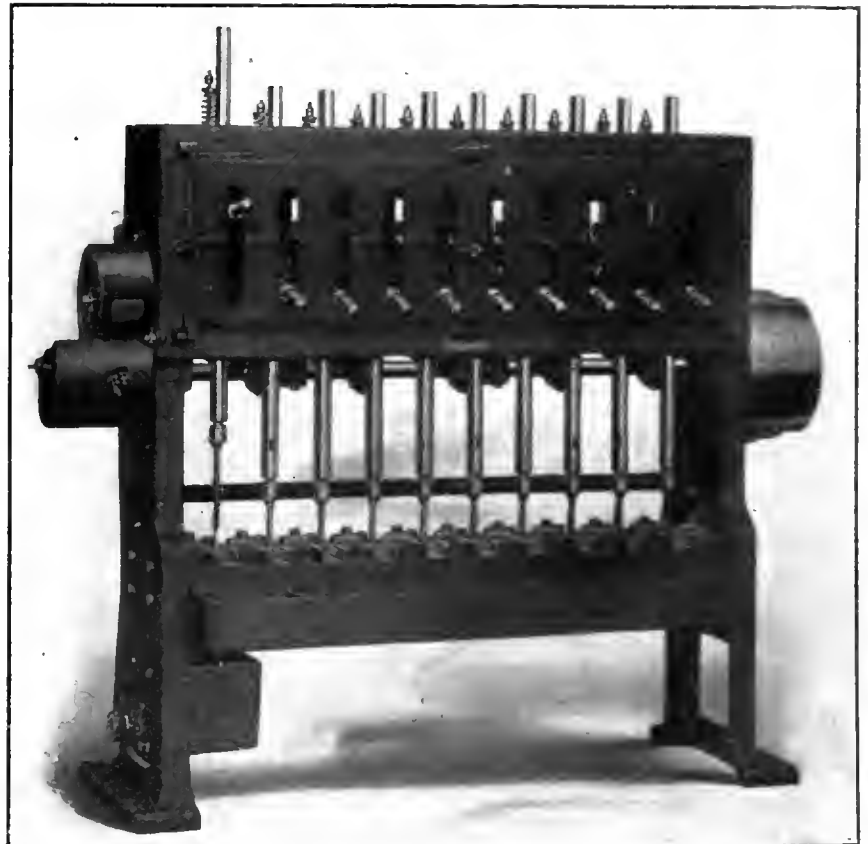

10 SPINDLE SEMI-AUTOMATIC NUT TAPPING MACHINE.

nut pans through which the operator can empty the taps into boxes or kegs set underneath. This taper will handle either rough hot pressed, or cold punched nuts.



NEW 16-IN. ENGINE LATHE.

THE 16-in. "Ciseo" engine lathe shown herewith is an excellent example of the work turned out by the Cincinnati Iron and Steel Company and has as its leading features, strength, durability and simplicity. These lathes are all manufactured by means of a complete equipment of tools, jigs and gauges, ensuring perfect interchangeability between like parts. Only two wrenches, those seen on the tool post and tailstock, are required on the entire lathe, every nut fitting one or the other of these. Careful attention has been given to lubrication of all bearings, and all gears are enclosed.

Screw threads from 3 to 64 per inch can be cut, and only two levers are required for the entire change in threads or feeds, these being made without having to change the gears. The lead screw is reversed at the head of the lathe and a safety device is provided between it and the feeds, making it impossible to engage both at once. When the screw is disengaged from the apron, the half nuts are automatically locked, thus preventing all possibility of their accidentally engaging with the screw.

The apron is of the double plate type,

but has as few working parts as is consistent with sound design. All non-essentials have been carefully eliminated. The feeds are obtained by means of a multiple pitch steel worm and bronze worm wheel running in oil.

headstock spindle, is made from .50 carbon spindle steel and runs in phosphor bronze bearings of liberal size. The carriage is of heavy construction with long bearings on the ways and a wide bridge. All carriages are jig drilled

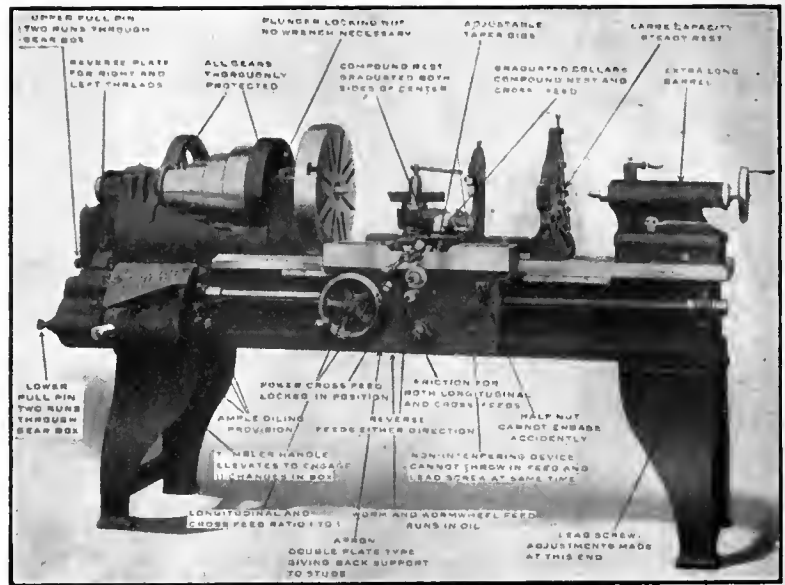

FRONT VIEW.—16-INCH "CISCO" ENGINE LATHE.

Longitudinal and cross feeds are independent, but are both obtained through the same friction, and can be reversed in the apron. The cross feed and top slide screws are both provided with micrometer graduations, and the swivel slide is graduated on each side. The

on the back to allow of a taper attachment being added at any future time.

Our illustrations show a lathe with a 6 ft. bed, but any length can be supplied advancing by 2-ft. units. The net weight of the lathe shown is 2,350 lbs., and the floor space occupied by it is 7 ft. 6 in. by 3 ft.

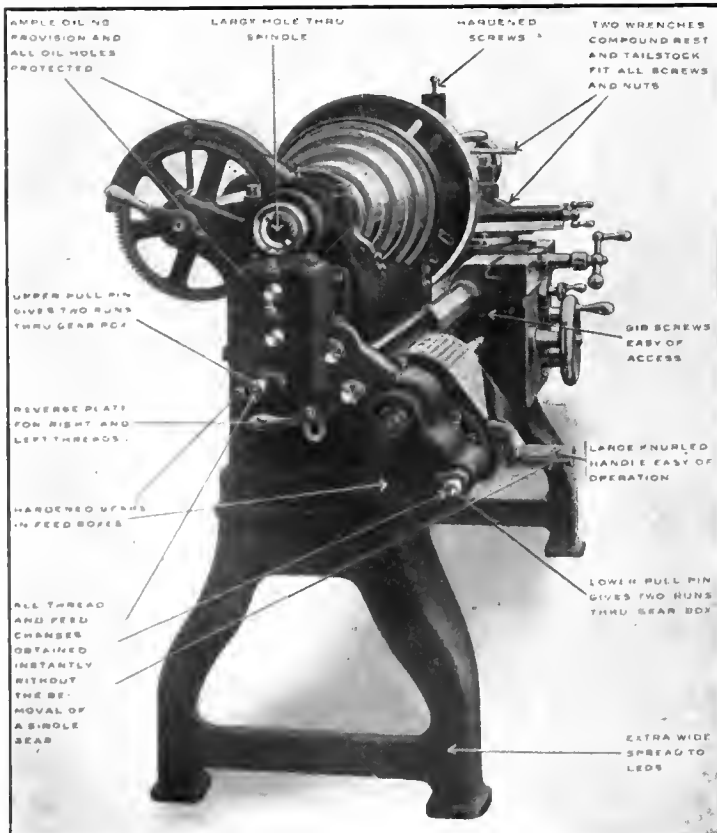

END VIEW.—16-INCH "CISCO" ENGINE LATHE.

MORROW CHUCK RIGHTS SOLD.

Morrow Drill Chucks are now manufactured by the E. Horton & Son Co., of Windsor Locks, Conn. The latter company, after studying the problem of producing a thoroughly reliable and efficient ball bearing chuck, and comparing all designs, decided that the Morrow Drill Chuck was of such design that it could be depended on under all conditions. They secured the Morrow Chuck, with all patents, equipment and tools, and transferred them complete to their plant at Windsor Locks.

It is hand operated, without the use of keys, spanner or wrench. Perfect alignment of all parts on plain bearings, large ball-bearing to take end thrust, automatic positive grip that never slips, and quick unresisting release by hand are features claimed for this chuck.

Mr. H. V. Hamilton has resigned his position as assistant sales manager with the Steel Co. of Canada, having accepted the post of sales manager to the Canada Steel Company, Hamilton, Ont.

THE APPRENTICE ENGINEER.

MR. SUMMERS HUNTER, in a recent address, said:—In an engineering works the apprentices appear to be divided into two classes, those who take advantage of all the facilities we can give them, and who work conscientiously in the shops and out of them—thus we get a small proportion of clever young fellows who will undoubtedly rise to all that is required in the future. Then there is the other class, who will eventually become our skilled workmen. We must give our attention to all, because it is just as necessary to have thoroughly skilled and well-trained workmen as it is to have the more highly educated, a number of whom will take more responsible positions.

I have apprentices in our works now who came from schools, where, at the age of 15 or so, they go on the science and engineering side for three years. At the age of 18 or 19 these lads are well grounded in science. They have had experience in the running and testing of steam engines, gas and oil engines, turbines, electrical apparatus, and even a certain amount of practical training under skilled workmen. Personally, I have got the best results from the lads who, after leaving school, go into the shops for a year, and after that divide their time between technical colleges and the works. Of course, this is a system that cannot be applied to the ordinary apprentice; at the same time, ordinary apprentices can take advantage of the system by qualifying at evening classes. I believe six months in the works and six months at college for three or four years would be found, on the whole, to give the best results. I am dealing now with mechanical engineering as quite apart from civil.

For the majority of apprentices who have to learn a specific trade, I believe more can be done in the future than we have attempted in the past. I have found a certain percentage of apprentices quite deserving of special education or training in practical work, and in the future I shall give more attention to this, for more accuracy is being called for, and we must produce skillful workmen who can make the best and most methodical use of the machinery and apparatus in the works. I have the greatest admiration for the mechanic who is able to turn his hand to any job about an engine, but as with the leaders, so with the workmen, men of special training will be required.

LOCOMOTIVE BLAST PIPE.

A PROPERLY designed variable blast pipe is an acquisition to a locomotive, and if used intelligently, economy and a higher general efficiency in the

performance of the engine are the result. According to the *Railway Gazette* an engineer has recently stated that while studying the question of locomotive design and operation abroad, he frequently rode on French locomotives, and noticed particularly the degree of refinement obtained in the steam distribution of four-cylinder compound engines. At speeds of from 56 to 62 miles an hour it was noticed that by a slight adjustment of the valve gear, which resulted in lowering the back pressure on the low-pressure pistons, the engine immediately increased its speed by about nine miles per hour, without taking any more steam from the boiler or increasing the regulator opening. The same engineer has also expressed the opinion that superheated locomotives would give an even higher efficiency than they do at present if fitted with variable blast pipe nozzles, and that wherever four-cylinder compounding is resorted to, there should of a certainty be an independent adjustment possible between the high-pressure and low-pressure valve gears.

THE UTILIZATION OF PEAT.

A report issued by the Canadian Department of Mines, deals exhaustively with the utilization of peat fuel for the production of power and with experiments conducted at the Fuel Testing Station, Ottawa, the results of which are given in numerous tables and curves. The report consists of about 140 pages, and is divided into two sections. The first section refers to the plant employed, consisting mainly of a 60 h.p. double-zone Korting gas producer, with wet coke scrubber, tar filter and dry scrubber, a Westinghouse 100-h.p. bituminous suction-gas producer, and a 60-h.p. four-cylinder, single-acting Korting gas engine, coupled direct to a 50-kw. Westinghouse generator.

New Tar Separator.

The second section contains a description of alterations carried out in the plant in order to eliminate difficulties connected with the formation of tar. These alterations were devised by Mr. F. B. Haanel, the compiler of the report, and involved the design of a new tar separator, in which a cone composed of 40-mesh brass wire is used as a filter in place of a cylinder and perforated plate. The gas, in passing upwards through the cone, deposits some of the tar on the metallic surface, and this is washed off by a water spray from the interior of the cone. The particles of tar that escape contact with the metallic surface of the cone in passing through the meshes are caused to coalesce and to form larger drops, which either adhere to the outside surface of the cone or drop to the bottom of the separator, as-

sisted by another water spray on the outside of the cone. The latter spray is connected by a two-way cock to the return cooling water from the gas engine, and should the suction in the separator begin to rise, the hot water is substituted for the cold, and in this manner the suction, whatever it may be, reaches normal in about a minute. This separator is stated to remove completely the troublesome matter from the gas, and to render the plant an unqualified success, so that operations may be carried on for a week or more without having to shut down for the purpose of cleaning the valves of the engine.

The consumption of fuel per h.p. hour, including stand-by losses, is, for full load 1.7 lb. of dry peat, or 2.3 lb. when containing 25 per cent. of moisture; and for three-quarter of load, 2.1 lb. of dry peat, or 2.8 lb. with 25 per cent. of moisture. Assuming that the peat can be delivered to the plant at \$2 a ton, and that the plant is run with a power factor of 75 per cent. for 3,000 hours, the fuel cost is \$8.40 per h.p. year, including stand-by losses. The peat employed varies slightly in composition, according to its source, but that taken from Alfred consists of 30 per cent. moisture, and, when dried, of 30 per cent. fixed carbon, 64.6 per cent. volatile matter, and 5.4 per cent. ash. The calorific value of the dry peat is 9,450 B.Th.U. per lb., and as charged 6,600 B.Th.U. Other details of the different qualities tested are also included, as well as numerous photographs, drawings, and diagrams.

ELECTRIC LOCOMOTIVES.

AS applied to electric locomotives, the multiple-unit system makes possible the concentration of very great tractive power, and makes it practicable by giving each locomotive an equal division of load, while requiring only one driver. As applied to motor car trains, the system permits of the application of great power to the axles throughout the train, and permits of the utilization of any desired train weight (up to the limit, when every axle is equipped) for driving adhesion at the rails. It is obvious that this makes possible very high rates of acceleration, and, consequently, high schedule speeds in a service where stops are frequent—such a service as is required in suburban and other local passenger operations.

APPLICATION OF BALL BEARINGS

AN interesting paper entitled "Application of Ball Bearings to Engineering," was recently read before the University of Liverpool Engineering So-

ciety. In dealing with the fitting of ball bearings, the author, Mr. George W. Goodchild, remarked that this is a very easy matter, generally speaking. The inner ring should be driven tight on the shaft, while the outer is a push fit in the housing, and should be allowed some side play.

Before mounting, the bearing should be allowed to lie in a bath of oil heated to about 104 deg. Fah., and then driven on the shaft, which should be a shade larger than the bore of the bearing, by a few good blows directed on the inner ring, carefully avoiding hitting the balls or outer race. This is particularly essential if the loads vary considerably, and when the bearing is subject to constant and considerable vibration, such as in crank shafts and rolling mills. It is also necessary for machines running at high speeds, such as electric motors, ventilators, woodworking machines, etc. It is very desirable that the shaft should be ground where it is proposed to fit a ball bearing; furthermore, the inner race should be clamped tightly on the open side, and it is essential that nuts or other parts holding the inner race in position should not come into touch with either cage or balls.

POWER TRANSMISSION OF BELTS.

THERE are cases when one cannot escape a leather belt. In such an event, don't be guided by the pulley face as to your size of belt. Mr. R. Berry's paper on the transmission of power by belting was discussed before the Birmingham Association of Mechanical Engineers a short time ago, and this is his rule: "Multiply the band speed in feet per minute by the width in inches, the result will be total energy in watts that the band can safely be relied on to transmit.

PASSENGER MOTOR CAR DEAD-WEIGHT.

SOME interesting comparisons were drawn by the author of a paper read recently before the Canadian Railway Club. Attention was called to the fact that a horse-drawn vehicle, seating on an average four passengers and a driver, weighs from 1,500 lbs. to 2,500 lbs., which gives a deadweight per passenger of from 300 lbs. to 500 lbs. Such a vehicle will move at a speed of from six to eight miles per hour over a road not comparable with the worst type of railway track. Again, a motor car weighing five tons and seating seven passengers and containing its own power plant, moving with almost the same average speed as a passenger train over a far inferior road bed, gives a deadweight per

passenger of about 1,428 lbs. The deadweight per passenger of a steel railway coach built after American ideas varies from 1,200 lbs to 1,700 lbs., and admitting the points of superior comfort and safety to be balanced by the poor road bed and the weight of the power plant of the motor car, the question arises as to whether any possibility exists of getting below the motor car limits of deadweight per passenger, and is this reduction possible without sacrificing safety and comfort?

THE ELECTRIC TRUCK.

By L. Rupprecht, M. E.

THE motor truck has made wonderful strides in the past two years. There is scarcely a line of business which has not adopted, at least in part, the horseless vehicle. There are, generally speaking, two types of motor trucks, gasoline and electric. Each type has its particular field, largely because one is more economical in one field than the other. The electric is the city and the suburban truck, while its running mate produces greater dividends in long haul work where few stops and a high rate of speed is desirable. As its title indicates, this paper concerns itself principally with the electric truck, and in common with other electrical apparatus, the early electric truck had an uphill fight. People couldn't or wouldn't understand how it should be cared for, and the result was that a great many pioneer users were dissatisfied, in spite of its simplicity and in spite of the fact that these old trucks are running to-day. They were naturally dissatisfied with their first gasoline touring car with its mysterious complications, but that, as a luxury, was not expected to produce dividends on the investment. The electric truck was expected to, and rightly handled, it finally did.

Durability, Efficiency, Dependability.

The durability, efficiency and dependability of the well-built electric truck is now thoroughly established. There are scores of such trucks in service, which are over ten years old; several thousand that are from three to eight years old, all doing good work. You may have noticed some of these old veterans running about our streets, and they deliver the goods in all kinds of weather at much less cost and with greater despatch than horses.

We all like to make fun of the "one-lunger," but we should not forget that without the first crude model we could never have the perfected machine. It is these "old veterans" running about New York for ten years that have given the electric truck such a boost—that has enabled one manufacturer to put 1,075 electric trucks on these New York streets, principally in the past two years,

and 490 heavy electrics into the service of 49 brewers. A business man has but to look at the early model and then at the 1912 product to see the evolution of the electric, and to understand why the pioneer buyers of electrics are putting in "fleets" of from 20 to 150 such trucks.

Universality of Service.

The electric truck is purchased in large quantities by leading merchants, manufacturers and express companies, because, for their work, it is the best paying investment they can make in power wagons. There will, however, always be work that the horse can do to better advantage than the motor truck. You must keep your motor truck busy a large part of the working day in order to get your money back, just as you expect to do with other machinery.

It is generally recognized that 80 per cent. of all average city trucking and deliveries can be most economically and efficiently handled by the electric truck or wagon, and in the matter of cost of operation and upkeep, the electric truck has certain fundamental advantages. In the matter of "fuel" it has a great advantage. Electrics are charged at night when there is little market for current which the power station must "grid out," as it were, regardless of selling it. That's why an electric truck customer gets a rate of from three cents to five cents, or less than half what he pays for his residence lighting. Electric current at four cents is equal to gasoline at ten cents, but gasoline is retailing at sixteen to twenty cents. Electricity is getting cheaper, gasoline prices are advancing. Then, too, the electric truck will last ten years, which means an annual depreciation of 10 per cent., against 20 per cent., or even 33 1-3 per cent. for the non-electric truck. The somewhat slower, consistent speed of the electric means less vibration, less tire expense (the largest single item of upkeep expense), and naturally longer life, and this slower speed, combined with simplicity of control, reduces liability to a minimum. Again, the simplicity of the electric enables a firm to break in regular teamsters, familiar with your conditions, as operators. A driver at \$12.00 or \$16.00, against a chauffeur at \$20.00 or \$25.00 a week, is an item of difference of \$400 per year in itself. Mention should also be made of about 40 per cent. saved on garage insurance with the electric truck. The advantages just cited are fundamental facts. Your work may require a gas truck regardless of its higher operation and maintenance cost, but if the electric can do the work you certainly have a dozen good dollars-and-cents reasons for buying it.

Electric Truck Mileage.

Electric truck mileages have come in for some criticism in years past, but those who use hundreds of these machines are better judges of what constitutes a good day's work than outsiders. A five-ton electric truck has a mileage of from 35 to 45 miles on a single charge of the battery. The speed is usually seven miles per hour, or over twice the average speed of heavy draft horses, and requires no rest. It is always possible to get 50 to 60 miles per day if you really need it. You can take a "boost" at noon or at one end of a run, or you can equip with extra batteries if more than eight hours' work a day is demanded. Current for a full charge costs, at four cents, an average of \$1.25.

Bear in mind particularly that investment in electric truck equipment and garage is very little greater, if not less, than the investment in horse equipment and stable of equal work capacity, and that is so whether your equipment is all electric or mixed electric and horse, or mixed gasoline, electric and horse. The investment when intelligently made pays bigger dividends than most modern machinery and, last but not least, motor trucks will extend your business area. In the heat of the summer, when horses are dropping by the thousands, the electric is there with the goods. You can work it 20 hours a day if necessary, instead of every other day as you do your horses. It is not uncommon for a good electric to work every working day in the year, and I need not remind you that the depreciation of city horses increases each year. A dead horse is a total loss, whether from sunstroke, broken legs or disease. This is an electrical age and the electric truck is part of modern progress. With practically all lines of industry about you adopting it, you cannot afford to lag behind. From a paper read before the Annual Convention of the Eastern Ice Association, New York, November, 1912.

PETROL, STEAM OR HORSE.

AN interview appears in The Commercial Motor on motor versus horse haulage, with the managing director of a large London brewery, which acquired 12 steam vehicles before the end of 1906, and two years later began to buy petrol vehicles, of which they now possess 12, of carrying capacities from 30 cwt. to 5 tons. They have also 150 horses. "We have found that there is work for both horse and motor; but cannot shut our eyes to the economies that have been effected by the use of the motor. Compared with hiring charges they are cheaper by a full 50 per cent. Our

own stable can, of course, work more economically than when we hire, but the motors will undoubtedly show a big saving over horses in a considerable additional portion of our work when we are able to change."

Petrol vehicles are preferred to steamers because they give a wider range of operation, although they have the disadvantage of greater tyre wear; but in tyre wear, the company have effected economy by fitting larger tyres than those supplied by the makers. On relative costs of running, the petrol vehicle was 50 per cent. higher than the steamer, but it gave approximately 33 per cent. more in mileage, while being cleaner in the yard and free from smoking on customers' premises. Any further decided increase of liquid fuel cost would tend to send the company into the hands of the steam vehicle makers. Meanwhile they are in search of petrol substitutes such as paraffin, benzol, or other. In comparative cost of horse and motor delivery, before the adoption of motor vehicles, the cost per barrel per mile seldom came below six cents, and with motor vehicles never exceeds 2 cents.

LABOR DISPUTES DURING DECEMBER, 1912.

THERE was a marked decrease in the number of labor disputes in existence in Canada during December as compared with the preceding month. The Department of Labor's record of strikes and lockouts shows there were thirteen labor disputes in December, and while this number is greater by 5 than that of the corresponding period of last year, it represents only about half as many as were in existence in November, when 25 were reported to the Department of Labor. The important disputes in existence were those of coal miners on Vancouver Island, miners at Poreupine, and freight clerks, etc., on the Canadian Pacific Railway, all of which commenced before December and continued throughout that month. About 3,500 employees were affected by disputes in December, 1912, compared with 3,900 in November, 1912.

The Department's index number of wholesale prices rose slightly during December, standing at 135.2 as compared with 134.8 in November and 129.4 in December, 1911. Commodities advanced slightly in nearly all groups, the only decline of importance being in grains and fodders. In retail prices the upward movement was not as strong as during the past few months, nor at the corresponding period of 1911, meats and dairy products being steadier.

According to the record of industrial accidents maintained by the Department,

97 workmen were killed and 357 injured during the month of December, 1912, as compared with 114 killed and 359 injured during November. The greatest number of fatal accidents occurred in steam railway service, building trades and navigation, the figures being 20, 17 and 12, respectively.

WROUGHT IRON REVIVAL.

THE Staffordshire Iron and Steel Institute held its opening meeting at Dudley recently, and discussed the largely extending use of Staffordshire wrought iron. When Bessemer steel was introduced, it was thought that wrought iron would be displaced. Lately, orders for thousands of railway wagons have been given, in which iron underframes have been specified in substitution for steel. Iron sheets are largely preferred to steel because of their resistance to corrosion. The merits of wrought iron and the need of improving its production, especially by a good mechanical puddling furnace, were set out in a paper by Mr. Herbert Pilkington. A letter was also read from Professor Turner pointing out the value of the local iron industry, and estimating a total output for 1912 in the district of over a million tons. Ten thousand persons in the Black Country, employed by 32 firms, were making wrought iron, while there were 661 puddling and 296 mill furnaces, every one working to its full capacity, and additional furnaces being erected. That was due partly to general good trade, and partly to recognition that the special properties of wrought iron justified rather higher prices for it than for mild steel. South Staffordshire was still the chief wrought iron producing centre in the United Kingdom.

In the discussion, the necessity was recognized of a good mechanical puddling furnace. Men are scarce and something must needs be done to attract puddlers into the trade. Several speakers complained of the insistence by engineers on the reduction of area test, which might be good for steel, but was of no good for wrought iron. Mr. Pilkington strongly commended the admiralty test for cable chains, which insisted on a good fibre, but took no account of reduction of area.

"WHAT I BELIEVE."

I BELIEVE that progress only means more light. That in the world today electricity leads the van of progress, and is the greatest agent for doing the greatest amount of good to the greatest number of people. That in advocating the use of electrical service I am helping to make life more cheerful, hopeful, healthful and useful."

DRY BLAST REFRIGERATION.

A NEW method of drying the air for blast furnaces by the aid of mechanical refrigeration has been perfected and is being introduced by the inventor, Charles H. Leinert, Chicago, Ill., says "Ice and Refrigeration." As an evidence of the merit of his apparatus, the inventor states that contracts have been concluded with representatives of the Krupp gun works, Essen, Germany, for installation of plants at two of their blast furnaces, with option for control

the water and robs it of a large portion of its moisture content.

From this preliminary cooler and dryer, the air passes through a passage at base of the cooling tower in which a spiral, made with expanded metal or similar material, rotates. This passage, or chamber contains in its lower part a concentrated solution of calcium chloride or other deliquescent re-agent which adheres to the surface of the expanded metal as it rotates, and thus further dries the air to about two grains

drier the air passes into the intake pipe of the blowing engines and thence to the blast furnace stoves where it is heated to about 1,500 degs. F., ere it is admitted in to the blast furnace.

The cooling tower, it is asserted, occupies much less space than the air drying plant heretofore used, and can be located conveniently on the roof of the building containing the blowing engines, or otherwise in close proximity to same. It is more economical to carry the liquefied ammonia to the tower than to conduct

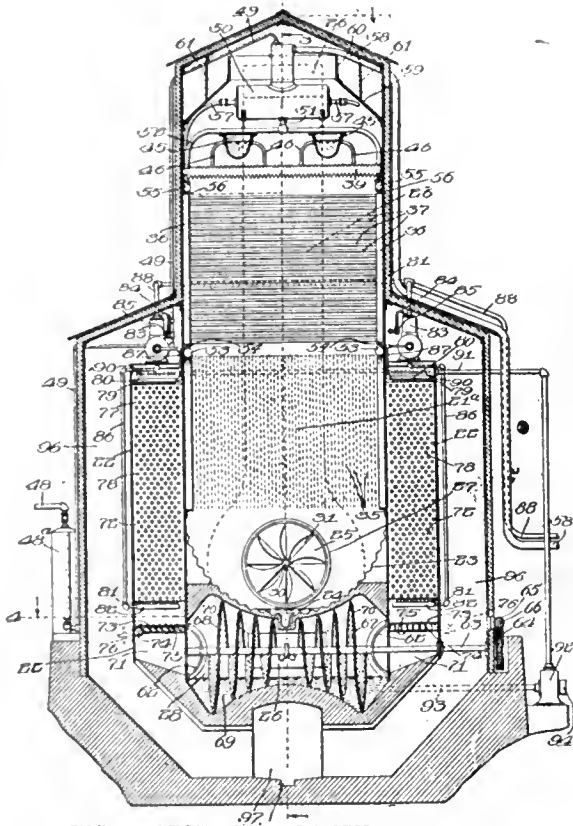

FIG. 1. SECTION THROUGH DRY BLAST AIR COOLING DEVICE.

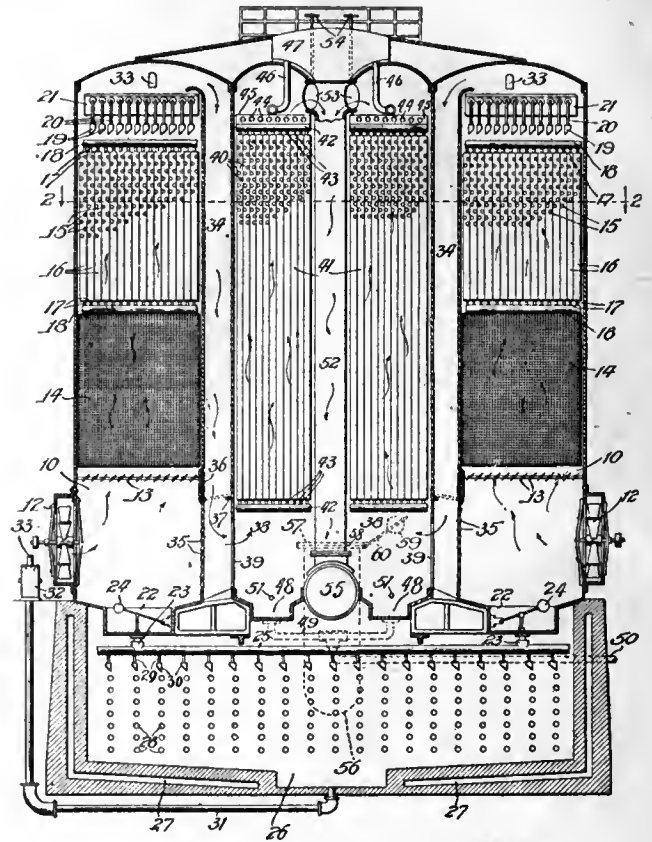

FIG. 2. PREFERABLE ARRANGEMENT FOR AIR DRYING SERVICE.

of the system in Germany if practical operation proves the method to be as effective and economical as is claimed. The Illinois Steel Co., South Chicago, **S**OME has secured the right to use the drawn for its blast furnaces. Patents read recently method and system of ap-way Club. Atte, been granted in the Unit-fact that a horse-drawny, Austria, France on an average four driver, weighs from 1, the air intended lbs., which gives a deadwis first introduc-senger of from 300 lbs. to 50 means of ro-a vehicle will move at a speed upwardly six to eight miles per hour overkling over not comparable with the worst ty. having railway track. Again, a motor car wea over ing five tons and seating seven passen a gers and containing its own power plant, re moving with almost the same average speed as a passenger train over a far inferior road bed, gives a deadweight per

per cubic foot, during its passage through the spirals. Two spirals are used, as may be noted in the illustration and these revolve in opposite directions. Air admission is at the centre, the revolutions of the spirals driving it to either side. Leaving this chamber, the air passes upwardly through a pair of chambers containing a large number of direct expansion pipes in which liquefied refrigerant, such as anhydrous ammonia, expands. As the air is already robbed of much of its moisture, comparatively little remains to be deposited in the shape of frost upon these pipes, and this deposit is prevented by causing a thin film of calcium chloride brine to trickle down over the pipes. By its passage over these, the air is deprived of its moisture to within one or one and a half strains per cubic foot. From this final

the very much greater bulk of air from the refrigerating plant to the blowing engines. Moreover, there is no stoppage of any part of the apparatus for the removal of frost accumulation on pipes. The water which trickles through the preliminary drying chamber collects in the bottom of same, and is pumped back to the troughs in the upper part of the chamber, or to the tank fitted with ammonia coils. As additional water is condensed from the air passing through this chamber, the surplus water is conducted through suitable pipes to the ammonia condensers, and on account of its low temperature, effects a considerable saving in the operation of the condenser.

Modified Method Apparatus.

A modification of the method and apparatus for air blast drying by means of refrigeration is illustrated in Fig. 2.

By the arrangement there shown, the penetration of outside heat to the final cooling chambers is effectually prevented by placing these at the centre, and placing the preliminary coolers and air purifiers at the sides. Referring to Fig. 2, air is driven into the preliminary cooling chambers (10), by means of rotary fans (12). Above the air chambers are a series of screens, or chain plates (14), which serve to sub-divide the cold water descending from above, so that as large a surface of water as possible is exposed to the action of the air which passes upwardly. Above the screens are a series of pipes (15), connected with vertical pipes (16), which are in turn connected with horizontal headers (18). The headers (18) and pipes (16) may be supplied with liquid ammonia, cooling the pipes (15), over which the down-pouring stream of water from troughs (19) and tank (21) flows. The water thus pouring down through the cooling tower is collected in a cement water reservoir (26), below the cooling tower. This reservoir is provided with pipes containing liquefied ammonia, over which the water is sprayed through troughs (30) from pipe (25). The water thus cooled is drawn off through pipe (31) by pump (32) which returns the water to top of cooling tower to be used over again.

The air leaving cooling tower at top, as indicated by the arrows, flows down the passages (34), and enters the final cooling chambers (38) at bottom through opening (39). These cooling chambers are supplied with direct expansion piping (40) (41) and horizontal headers (42). Just above the headers are pipes (44) (46) communicating with tank (47), containing calcium chloride brine, which, passing through slits in pipe (44), falls in a thin film over pipes (40) and prevents the accumulation of frost on said pipes. The Ca.Cl. brine collects in troughs at bottom of chamber, and through pipes (49) and (50) is pumped back to tank (47). An overflow (51) serves to lead the calcium chloride to a concentrator when the solution becomes too dilute. Regulators are provided for controlling the flow of the cold dry air from final coolers to blowing engines, to which it passes through pipe (55) and blowing engine intake (56).

Suitable provision is made for cutting out the preliminary cooling tower when desired, for which purpose, louvres (35) are placed in wall of preliminary cooling chamber, the opening of which sends the air directly to the interior final air coolers. Thus, when the outside temperature is above 40 degs. F., the air is passed through both preliminary and final coolers. If temperature is between 20 and 40 degs. F., the

air is passed only through final cooling chambers, and if outside temperature is below 20 degs. F., the cooling tower is entirely cut out and air admitted directly to intake of blowing engines. Broadly speaking, the novelty in this new method consists in the use of preliminary cooling, and final cooling and drying means.



UNITED KINGDOM EXPORTS TO CANADA IN 1912.

FIFTY-THREE THOUSAND loads of hewn wood and \$95,000 loads of dressed wood were exported from Canada to the United Kingdom. Exports from the latter to Canada include:

	Tons, 1912.	Tons, 1911.
Fig Iron	68,024	91,024
Wrought iron	6,563	8,748
Rails	737	1,730
Boiler plates	2,801	6,696
Galvanized sheets	26,248	22,476
Tinned plates	7,039	12,426
Steel bars and shapes	14,276	28,250
The value of the further exports were as follows:		
Cutlery	\$ 590,400	\$ 515,500
Hardware	585,980	516,040
Carpets	2,250,595	1,850,755
Haberdashery	886,015	708,410
Linon piece goods	1,733,260	1,400,575
Waterproof apparel	1,111,815	503,510
Glass and earthenware	2,342,315	1,975,620
Writing paper	74,305	112,985
Printing paper	733,780	648,660



WOOD BLOCK FLOORS.

ONE of the very best types of floor, incidentally rather an expensive floor, is the creosote or hardwood block laid end-grain. The Abertlaw Construction Co., of Boston, in a recent investigation, found that several paper mills have used these with considerable success. The floor has the advantage of resisting water conditions, of standing up under the hardest trucking, of being a resilient, noiseless floor and one which can be kept very clean. For practical use in this country, creosoted blocks are most commonly used. Where these are laid on a concrete floor, the best practice is to dip them in tar and stick them down to the floor, then grout between the blocks with cement. A 3-inch block has sufficient depth.



BRITISH OR "EMPIRE MADE."

THE text of the Merchandise Marks Act, which was recently introduced in the British House of Commons, and which seeks to amend the law as to trade marks and descriptions, is now published. The measure provides that all goods bearing description liable to make the purchasers believe that they have been manufactured within the British Islands shall be marked with the

word "British." They shall be marked "Empire-made" if manufactured in any part of the British Empire outside of the British Islands, or with the words "Not British" if manufactured outside of the British Empire. All goods marked "British" and "Empire-made" in accordance with this provision are to be accompanied by a sworn declaration before a commissioner for taking of oaths that the goods were manufactured within the British Empire.



BRITAIN'S TRADE INCREASES.

RECORD increases in the trade of the United Kingdom of Great Britain and Ireland are shown by the Board of Trade figures for the year ending December, 1912.

With total imports of approximately \$3,724,482,570 and total exports of \$2,437,170,010 the aggregate increase reaches the enormous sum of \$490,268,455. The respective increases were: In imports, \$323,694,935 and in exports \$166,573,520.

Grain and flour account for upwards of \$60,000,000 of this increase in imports, and other food for nearly \$20,000,000. Tobacco is responsible for \$5,000,000 increase, cotton from America for \$32,500,000. The principal increase in exports were in iron and steel \$50,000,000, coal \$20,000,000, and in textiles \$10,000,000. The imports of bullion during the year totalled \$357,110,385 against exports of \$323,621,065.



STEAM AND ELECTRIC DRIVING.

AN investigation carried out in the United States by the Worcester (Mass.) Electric Light Co., in regard to the relative cost of operating a small machine shop by steam and electricity, has shown a saving of \$143 yearly in favor of electric driving. Previous to the conversion, a steam boiler and engine, the cost of which was \$1,500, supplied an average of 15.3 h.p., and, including wages, fuel, water, interest, depreciation, and repairs, the cost of maintenance was \$1,664 a year. In place of this plant, four electric motors of a total of 30 h.p. were installed at a cost of \$507, the boiler, which had cost \$600, being retained for heating purposes. Including interest, etc., energy, coal for heating, and labor, the cost of operating by means of the electric drive amounted to \$1,521 a year.



A micrometer used by a Swiss watch company accurately measures parts to the hundredth of a millimeter.

The MacLean Pub. Co., Ltd.

(ESTABLISHED 1888.)

JOHN HAYNE MACLEAN - - - - - President
H. T. HUNTER - - - - - General Manager

PUBLISHERS OF

CANADIAN MACHINERY

AND MANUFACTURING NEWS

A weekly newspaper devoted to machinery and manufacturing interests, mechanical and electrical trades, the foundry, technical progress, construction and improvement.

H. V. TURRELL - - - - - Business Manager

PETER BAIN, M.E. - - - - - Editor
J. H. WILLIAMS - - - - - Associate Editor

OFFICES:

CANADA	GREAT BRITAIN
Montreal , Rooms 701-702 Eastern Townships Bank Bldg.	London , 88 Fleet Street, E.C. Phone Central 12960 E. J. Dodd
Toronto , 143-149 University Ave., Phone Main 7324	UNITED STATES
Winnipeg , 34 Royal Bank Bldg., Phone Garry 2313	New York , R. B. Huestis 115 Broadway, New York, N.Y., Phone 2209 Rector
	Chicago , A. H. Byrne Room 607, Marquette Bldg. 140 S. Dearborn St., Chicago

CABLE ADDRESS:

Macpubco, Toronto. Atahck, London, Eng.

SUBSCRIPTION RATE:

Canada, \$2.00; United States, \$2.50; Great Britain, Australia and other colonies, 8s. 6d. per year; other countries, \$3.00. Advertising rates on request.

Subscribers who are not receiving their paper regularly will confer a favor on us by letting us know. We should be notified at once of any change in address, giving both old and new.

Vol. IX. JANUARY 30, 1913 No. 2

PRINCIPAL CONTENTS.

The Geo. White & Sons Co. Plant, London, Ont.	65-69
Oil Engines for Trains—The "Paragon"	69
General	70
A High Speed File...Toll of Railways...Canadian Railway Profits.	
Machine Shop Methods and Devices	71-73
A Hint for Draftsmen...A Collapsible Pipe Tap... Chuck Jaws for Gripping Thin Castings in a Lathe... Taper Shank Drift...Boring a 4-ft. Drum on a 12-inch Lathe...New Cam Device on a Drill Jig...Two Handy Home-made Tools...An Unusual Job for a Lathe.	
The Doty Marine Engine & Boiler Co., Ltd., Goderich	73
General	74
Titanium as a Cleansing Medium in Steel Manufacture ...New Electric Locomotive.	
Developments in Machinery	75-80
A New Shaper...Combination Saw and Rotary Planer ...Floor Type Boring, Milling, Tapping and Drilling Machine...Slocumb Micrometer Case...Acme Expanding Reamer...New Canadian Die Stock...New Square Cap Double Seamer...Ten-Spindle Semi-Automatic Nut Tapping Machine...New 16-inch Lathe...Morrow Chuck Rights Sold.	
General	81-85
The Apprentice Engineer...Locomotive Blast Pipe... The Utilization of Peat...Electric Locomotives... Application of Ball Bearings...Power Transmission of Belts...Passenger Motor Car Deadweights...The Electric Truck...Petrol, Steam or Horse...Labor Disputes During December, 1912...Wrought Iron Revival...Dry Blast Refrigeration...United Kingdom Exports to Canada...Wood Block Floors...British or Empire Made...Britain's Trade Increases...Rubber from Turpentine, etc.	
Editorial	86
General	87-88
The Vaulain Drill...The Chadwick Brass Co... Immigration Figures...Some Fundamentals in Handling Men...Toronto Firm Extends...Gossip of the Trade.	
Foundry Practice and Equipment	89-90
A Self Propelling Sand Mixer...Pease Foundry Celebration...Molding a "Fair-Lead."	
General	90-91
Prizes for Articles on the Utilization of Waste... Sugar Refinery for St. John, N.B...Heat Indicator for Bearings.	
Features of the "Fulton" Water Cooled Mechanical Stoker	92-94
General	94-96
Bad Tools Make Good Workmen...The Pollard Mfg. Co. Industrial and Construction News—Advertising Section.....	82-88

SHIPBUILDING A STAPLE INDUSTRY FOR CANADA.

A FEW days ago, representatives from the leading shipbuilding concerns established in various parts of the Dominion waited on the Premier and laid before him their ideas on the subject of the necessity of Government assistance in propagation of their enterprise. It was pointed out that a restricted sphere of operation was only, meantime, possible on account of the free import of Canadian registered, British built ships. In a word, protection of some effective kind was sought to offset the preponderance of production east in favor of Great Britain. The extension of the scope of the shipbuilding and marine engineering industry in Canada is generally accepted as but the natural outcome of the progress and development made during recent years, and the expressed desire on the part of her citizens to emulate the achievements of the Motherland, with respect to her own requirements as well as the winning of international maritime renown. As a "Nation within an Empire," no difference of opinion, amounting to anything material, exists relative to duty to ourselves and to the Empire whose nurture and protection has contributed so largely to our present status. Our industrial record continues to expand in well established engineering and manufacturing pursuits concurrently with agricultural and mineral wealth development, and beyond the feature of the protection of our shores, our transportation needs fall to be accounted.

The proposal to aid the Imperial Navy will meet with its strongest support by propagating already established shipbuilding and marine engineering industries, and by furthering an increase in their numbers and scope. Readers of and advertisers in Canadian Machinery have a large interest in this question, for in no one other individual completed product of man's inventive and constructive genius do so many accessory industries live, move and have their being. Shipbuilding and marine engineering embraces within its scope our iron and steel plants, our foundries and our machine shops, and, needless to say, in numerous cases, equipment for these compares on equal footing with the requirements of other sections of the engineering field.

The reported establishment by the United States Steel Corporation of an extensive plant on Canadian territory indicates the drift and trend of iron and steel trade affairs, and although much of the detail already arranged in this and other directions has been accomplished under cover of the increasing requirements of our great railroads, the fact remains that the broader field, consequent on what might almost be called the inception of a new industry, that of shipbuilding and marine engineering, is the goal furnished by the provision being made to meet an early future demand. Again, the extensions to and modernizing of old established steel and iron foundries, machine shops, etc., in all of the leading industrial centres of the Dominion, have for their objective a coming boom time in Canada's trade and commerce, and anticipate, in no uncertain manner, the institution, on a much larger scale than hitherto, of the shipbuilding and marine engineering industry.

Our contemporary, "Marine Engineering of Canada," in an article entitled "Canadian Shipbuilding Development," says "that in view of Canada's offer of three super-dreadnoughts, the keels of which will, however, have to be laid down in the United Kingdom, it is of interest to note that very soon it will be possible to build ships in the Dominion, as, according to all accounts, good progress is being made with the creation of the necessary establishments.

THE VAUCLAIN DRILL.

THIS heavy-feed drill which has lately aroused widespread interest, aims to eliminate many of the inherent defects of the ordinary form of twist drill; and the following, which is taken from a paper read before the American Society of Mechanical Engineers, shows in an analytical manner how the result has been attained.

Speaking generally, there can be no better definition of economical drilling than "rapid drilling"—the saving of time. The fact that a drill will cut at some phenomenal speed, or will consume such and such an amount of power means nothing so far as productive capacity is concerned. The object in view is the removal of chips.

Cutting stress is practically independent of the cutting speed, and with a given feed, is proportional to the lip angle of the cutting edge. The cutting stress does not increase as rapidly as the feed.

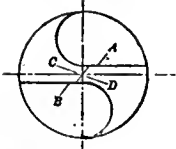

FIG. 1.—COMMON TYPE OF TWIST DRILL.

Since both the stress and heat are influenced by the keenness of the cutting-edge, it is desirable that the lip angle be as small as possible. But it must be blunt enough to carry off the heat and to support the chip pressure, which falls more or less back of the actual cutting edge, according to the depth of the feed. Since the chip is torn, not cut from the work, rupture

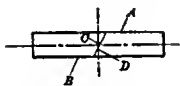

FIG. 2.—COMMON TYPE OF FLAT DRILL.

between work and chip precedes the actual cutting edge. The heavier the feed, the farther back from the cutting edge will its pressure fall upon the tool.

The feed remaining constant, the horsepower consumption will be proportional to the speed. This is true both of the power consumed by the machine and that consumed in cutting. The speed remaining constant, the power consumed in cutting does not increase as rapidly as the feed, and the power consumed by the machine remains constant for all feeds.

From this it will be seen that the most economical method of chip production is by giving preference to the feeds, rather than the speeds. Power, time and drills will be saved thereby.

Figures 1 and 2 illustrate the section scheme of drills now commonly used.

While there are many modifications of these, the figures suffice to illustrate their common characteristic, which is that the cutting edges A and B pass to one side of the axis of motion of the drill instead of through the axis. In this respect there is no difference between Figures 1 and 2.

It will be seen that in this scheme the drill has four distinct edges, A, B, C and D, and that the usual name

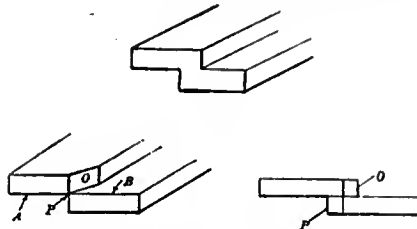

FIG. 3.—PRINCIPLES OF VAUCLAIN DRILL.

given to it of "two-lip" drill is not correctly applied.

It is ensomary for the included angle E to be of 118 deg. and the cutting edges C and D, Figures 1 and 2, therefore have an unfavorable lip angle. These edges constitute what is commonly called the chisel point and their resistance is very great. The cutting edges A and B cut more freely than the cutting edges C and D and a tendency to longitudinal fracture of the drill is set up thereby. This is the cause of the splitting of drills.

In the commonly used types of drills there are but two methods of reducing the chisel point, viz., by thinning the drill at its centre, or by pointing. By the former method the resistance to longitudinal splitting becomes lowered and by the latter method the cutting edges lose their support at and near the centre of the drill.

By the foregoing it will be seen that the feed possibilities of the ordinary types of drills are not very great. Either the drill will split or its cutting edges will break under heavy feeds,

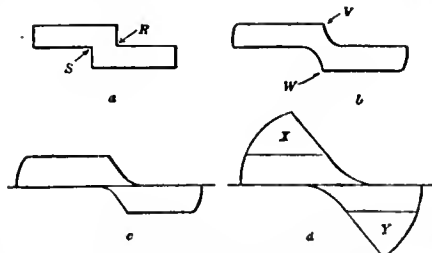

FIG. 4.—PROGRESSIVE DEVELOPMENT OF VAUCLAIN DRILL.

long before its torsional capacity is reached. Summed up, the disadvantages of this type of drill are as follows: (a) its weakness; (b) the unfavorable cutting lip angles of the chisel point create a tendency to longitudinal splitting of the drills: (c) if the chisel

point is reduced by central thinning of the drill, the resistance to longitudinal splitting is lowered; (d) if the chisel point is reduced by pointing, the cutting edges are deprived of their essential support at and near the center of the drill; (e) essential central thickness and cutting edge support are obtained only in connection with a considerable chisel point; (f) the tendency to longitudinal splitting is increased by any increase in the extent of the chisel point; (g) the resistance to penetration due to the chisel point is very great and is increased by any increase in the extent of the chisel point; (h) it is not adapted to heavy feeds, and must therefore be used under the conditions of moderate feeds and high speeds, the least economical method of chip production; (i) there are four cutting edges, two of which do not pass through the axis of motion, hence the aggregate length of the cutting edges is excessive. This is productive of greater torque, hence of power consumption.

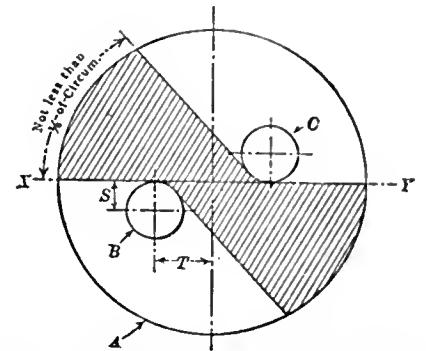

FIG. 5.—EXACT FORM OF CONSTRUCTION OF VAUCLAIN DRILL.

In order to better describe the Vauclain drill, the section scheme will first be explained diagrammatically and the development of the actual section will then be illustrated.

In the upper part of Figure 3 is shown a bar comprising two flat bars overlapping and integrally connected, as indicated.

By beveling, as shown at O and P, below in Figure 3, the edges A and B meet at the axis of the bar. Since these beveled surfaces are at an angle with the axis the integral connection between the two flat bars remain unbroken.

Figure 4-a again shows the section or end view of the bar in its original form. Introducing fillets at R and S gives the form shown in Figure 4-b and removing the corners W and V modifies it as in Figure 4-c. In Figure 4-d, by adding areas X and Y to the section, its torsional value is increased.

Figure 5 shows the exact section profile of these drills.

By examination of these diagrams it will be seen that the chisel point is

eliminated without central thinning of the drill and without weakening the cutting edges.

The improved design of this drill has brought about the following important features: (a) essential central thickness is secured; (b) cutting edges are properly supported at all points; (c) chisel point, with its unfavorable lip angles, is eliminated without weakening drill or cutting edges; (d) cutting edges pass through axis of motion; (e) there are only two cutting edges; (f) aggregate length of cutting edges is reduced to minimum.

As a result of these features the following advantages are secured: (g) increased strength and reduced liability to splitting; (h) it is adapted to heavy feeds, the most economical method of cutting metal; (i) productive capacity is increased; (j) horsepower consumption per unit of metal removed is reduced; (k) life of drill is increased and frequency of grinding is less; (l) distress in machine is less and resistance to penetration is reduced; (m) the afterwork of reaming is less.

THE CHADWICK BRASS CO, LTD., HAMILTON ONT.

THIS company was incorporated last month for the purpose of taking over the large brass manufacturing business of Chadwick Bros., Hamilton. Additional capital to the extent of \$250,000 has been added and land has been purchased with a view to largely increasing the size of the plant. Four hundred men will be employed, and it is intended to double the present output of the works. The policy of the business will be entirely changed and will be controlled by Henry J. Turner, vice-president and general manager, formerly secretary and sales manager of the U. S. Hame Company, of Buffalo.

The president of the new concern is F. W. Baillie, of Baillie, Wood and Croft, the well known Toronto financiers. The directors include W. M. Currie, of the Canada Steel Co., Arthur and Fred Cradwick, of Hamilton, and A. Pardoe, of Toronto.

Mr. Turner, who will be the active head of the new concern, although he has been away from Canada for twenty-eight years, is a Canadian and a native of London, Ont. He was one of Buffalo's most prominent business men, ex-president of the Black Rock Manufacturers' Association and former chairman of the transportation committee of the Buffalo Chamber of Commerce.

The directors confidently expect that the business will develop into one of the largest of its kind in Canada. The company has been entirely reorganized and important plans are under way to

extend the scope of the firm's operations under the most modern business methods.

Catalogues are now being prepared which will give the company's customers full information as to the various styles of goods manufactured.

IMMIGRATION FIGURES.

DURING the 9 months, April 1 to December 31, 1912, 334,083 immigrants arrived in Canada, 113,798 being from the United States, the remainder coming in by ocean ports from Britain and all other countries. These figures show an increase of 14 per cent. as compared with the number of arrivals in the corresponding months of 1911, which were 185,151, and 107,365 from the United States, making a total for the nine months period, last year, of 292,516 persons.

During the month of December, this year, there were 13,025 arrivals, 7,262 of them having been at ocean ports, and 5,763 from the United States, as against 10,624 for December last year, 4,945 of whom were at ocean ports, and 5,679 from the United States.

Varying the comparison, we have for the same nine months: British, 127,875; United States, 113,798; all other countries, 92,410; total, 334,083. Corresponding months of the preceding fiscal year: British, 120,137; United States, 107,365; all other countries, 65,014; total, 292,516.

Comparing the calendar year 1912 with 1911, immigration figures are as follows: 1912—British, 145,850; American, 140,143; other countries, 109,802; total, 395,804. 1911—British, 144,076; American, 131,114; other countries, 75,184; total, 350,374.

SOME FUNDAMENTALS IN HANDLING MEN.

By G. C. Webster.

A MAN can serve well only when he knows to whom he is responsible and for what he is responsible—in sequence of their importance—in which case he can serve more than one, if all are in accord as to the sequence of importance.

A man can serve well only where he knows that he is receiving full credit for his work and his ideas.

A man can serve well only when the work he is doing fits into his nature, and the environment is such that his mind is free from all irrelevant thoughts.

A man can serve well only when he has peace of mind.

To serve well, one must first possess the desire to serve.—The Business Philosopher.

Gossip of the Trade

The Dennis Wire and Iron Works Co., Ltd., London, Ont., whose business has rapidly increased of late years, are planning considerable additions to their plant for 1913. On January 1st, the ratepayers carried a by-law by a large majority, for the purpose of guaranteeing the bonds of the company to the extent of \$25,000. A further \$10,000 to \$15,000 cash capital, in addition to the firm's present paid-up capital, will be subscribed and paid in by the present directors and shareholders. This additional capital will be used for the purpose of extending the firm's premises and installing new equipment. It is also the intention to commence manufacture of one or two new lines, particulars of which will be announced later.

In connection with the improvements the present steel locker shop will be greatly enlarged and new facilities added. When these alterations and additions are completed, this locker plant will be one of the largest and most efficient on the continent.

Twist Drills for Australia.—According to an American commercial agent in Australia, while, with the introduction of high-speed steels, every British maker put a line of twist drills on the market, and these made great headway at first, shop managers have come to realize that they are too expensive. He states that, as a result, American twist drills are rapidly returning to favor. For example, the stores schedule of the South Australian Railway and Government Departments for 1911-13 shows that most of the twist drills contracted for in this period are to be either Cleveland or Morse, whereas in previous years the contracts have been made with British makers. It is well to remember that the import duty on drills is very high.

Mr. M. J. McCann, traveling salesman for the Renfrew Machinery Co., wins the grand prize of \$100 which the company hung up for competition among its salesmen. Mr. McCann disposed of more cream separators than any other salesman.

TORONTO FIRM EXTENDS.

FIVE years ago, the premises of the Toronto Testing Laboratory, Ltd., were ideal for their laboratory work. In that time the business has grown to such an extent that more commodious premises became necessary. These have been found at 160 Bay Street, Toronto, where the firm will be able to maintain the high standard of their service, and to keep abreast with the wonderful development in the metallurgical field.

FOUNDRY PRACTICE AND EQUIPMENT

Practical Articles for Canadian Foundrymen and Pattern Makers, and
News of Foundrymen's and Allied Associations. Contributions Invited.

A SELF-PROPELLING SAND MIXER.

AT the Foundrymen's Convention held in Buffalo in September last a working exhibit that attracted wide attention was that of the self-propelling sand-cutting and mixing machine herewith illustrated. This machine is now being built for the Canadian market by the Sand Mixing Machine Co., of Canada, whose head office is located at Brantford, Ont.

Fig. 1 shows a front view and Fig. 2 a rear view of the machine, and from these a good idea of its construction may be obtained. The mixer operates on the foundry floor where the sand is shaken out of the flasks. It is driven by a $7\frac{1}{2}$ H.P. electric motor mounted on the machine. Current is taken from any

blades draws the sand to the centre, leaving the heap triangular in section, just as when cut by hand. The knives revolve at 75-80 R.P.M., each blade taking $\frac{1}{2}$ -inch off the sand heap at each revolution. The shaft upon which they are mounted can be lowered to suit the height of the heap by means of the small vertical winch seen on the front of the machine—Fig. 1.

In operating, the machine is backed up against the foundry wall astride the sand heap and travels forward at a speed of 15-20 feet per minute. The knives, as they are lowered, cut their way to the floor, throwing the sand back towards the wall. The cutting knives are controlled by a multiple disk clutch, which will slip and prevent breakage should the

Mr. N. D. Neill is general manager of the Canadian company, who are open to either lease these machines or sell them outright.



PEASE FOUNDRY CELEBRATION.

NOVEMBER 12th was the 22nd anniversary of the opening of the Pease Foundry at New Toronto. The men in the shops wished to celebrate the event, and decided on Friday, January 10th, 1913, as a suitable day on which to show their appreciation of the mechanical superintendent, Mr. J. W. Phillips. On the above date the firm held an "at home," and this year over 250 people were present. This was held at the company's other plant, at the head of Shaw Street. Mr. D. W. McKinnon, president of the Pease Foundry Co., made the presentation of an illuminated

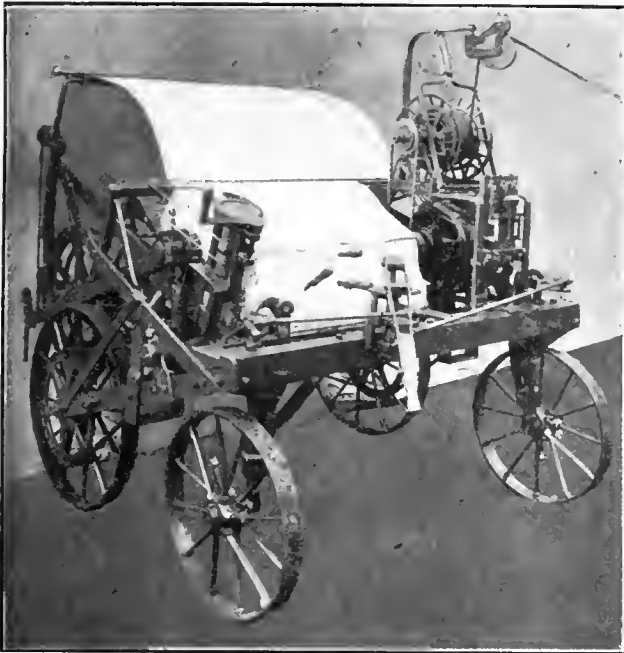

FIG. 1. FRONT VIEW OF SAND MIXING MACHINE.

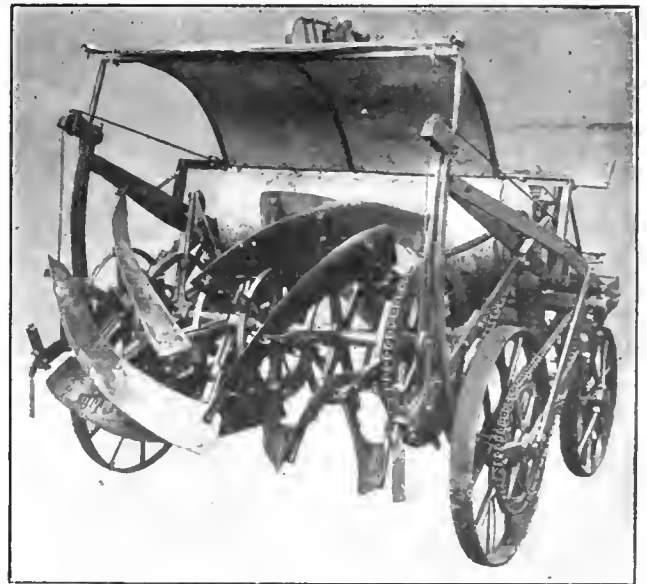

FIG. 2. REAR VIEW OF SAND MIXING MACHINE.

convenient source by means of a flexible cable wound on an automatic take-up reel. Steering is effected by hand through the wooden lever seen in Fig. 1. The machine has two speeds forward and two back. It is of thoroughly substantial construction and is not by any means an experiment, having been in successful use in the United States for the last five years.

The knives operate in the same manner as in an ordinary batch mixer, the blades being arranged in two opposing spirals so that the sand is very thoroughly mixed. Moreover, this arrangement of the

blades strike a heavy casting or gate left in the sand.

One man operates the machine and does all the work of cutting for an entire foundry. The method usually employed is to run the machine over the floor at night after the castings have been removed to the cleaning department. The sand is thus cut and mixed all ready for the moulders the next morning. The mixer can be operated successfully in almost any foundry and, where 100 moulders are employed, will, it is claimed, pay for itself in one year.

address to Mr. Phillips, who thanked the men. He was followed by a friend, Mr. Agar, who said a few words in appreciation of the mechanical superintendent.



A prosperous city.—Eight new industries were located in Berlin, Ont., during 1912, and additions were made to fifteen manufacturing establishments.

Wanted a free site.—A New York manufacturing concern recently applied to the Maisonneuve city council for a free factory site. It was refused.

MOLDING A "FAIR-LEAD."

By J. H. Eastham.

MOLDERS accustomed to marine and dockyard work will be familiar with the type of casting technically termed a "fair-lead," shown in plan and end views by Fig. 1. An order for a

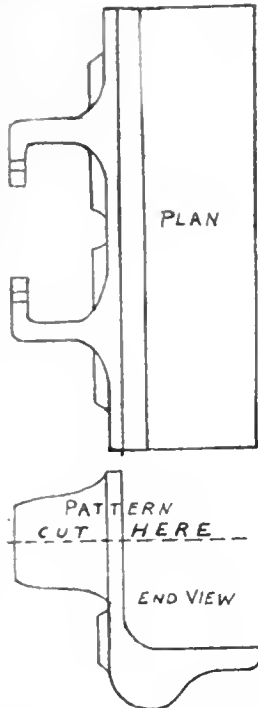

FIG. 1.—MOLDING A FAIR-LEAD.

number of these castings, from a customer's pattern, was recently placed in a jobbing shop at a price necessitating rapid output and small outlay on rigging. The method adopted for molding the piece was as follows:

The lower or larger piece of the pattern was bedded in the floor. The joint

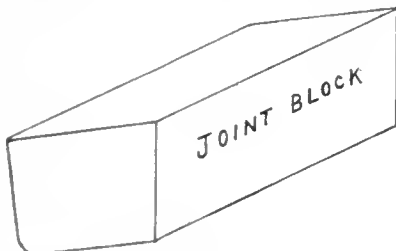

FIG. 2.—MOLDING A FAIR-LEAD.

block, Fig. 2, roughly built by a carpenter, was lowered into the pattern, and the whole rammed round, up to the floor, or joint level. The block was now removed, and the sloping joints left by its two ends and the side opposite the pattern were lined up with wet parting sand. One inch of facing sand was next spread over the bottom surface of the sunken joint and pattern and a lifting grid, or drawback, lowered to place—as shown in Fig. 3. A row of short gagers was con-

sidered advisable along the front of the lift, the core being then rammed up to the level in the usual way. An ordinary pipe cope part, with slight alterations to the bars, easily covered the top half of the pattern. This was next rammed up and hoisted away, two wood screws carrying the top half of the pattern at the same time. The drawback was then removed by means of a short

wedge down a plate laid across that portion of the drawback and lower section of the mold not covered by the narrow cope. Undue strain whilst pouring was thus avoided.

As in castings of this and similar types great strength is of more importance than an elaborate finish, exceptional care was taken in the mixing of the iron charged for this contract. The results

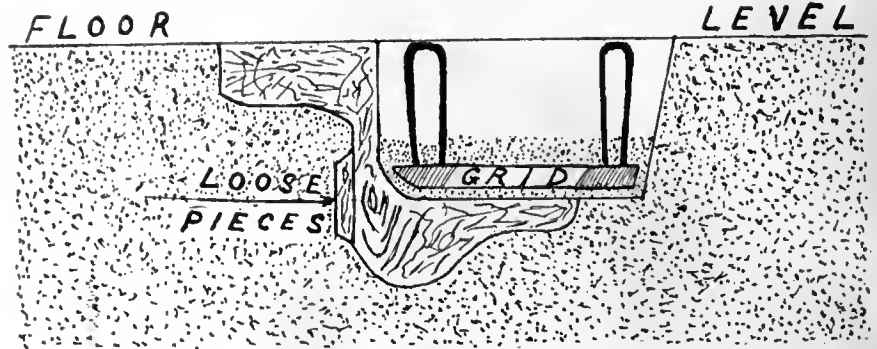

FIG. 3.—MOLDING A FAIR-LEAD.

three-legged chain and turnbuckles, the liberal amount of taper left by the joint block making this operation possible with very little "ragging" or breaking of the lift. This was eminently desirable as the drawback was finished and blackened whilst suspended from the crane, and remained in that position until finally lowered into the mold, after the withdrawal of the drag, and placing of three bolt hole cores in their respective places.

The cope being finished, tried on and satisfactorily closed, two rails were packed up across it, and a weight lowered upon them. The overhang of the rails as will be seen in the end view of the closed mold at Fig. 4, was utilized to

were highly satisfactory, test bars 24-in. x 2-in. x 1-in. showing a breaking point as high as 3,140 lbs., with 5/8 in. deflection.



PRIZES FOR ARTICLES ON THE UTILIZATION OF WASTE.

IN a recent issue of the N. E. L. A. Bulletin, Mr. H. F. Frasse, purchasing agent, the Brooklyn Edison Co., writes as follows regarding his offer of prizes for articles on the utilization of waste:—

I am glad to note the acceptance by the Executive Committee of my offer of three prizes of \$25, \$15 and \$5 for the best articles by members of the Associ-

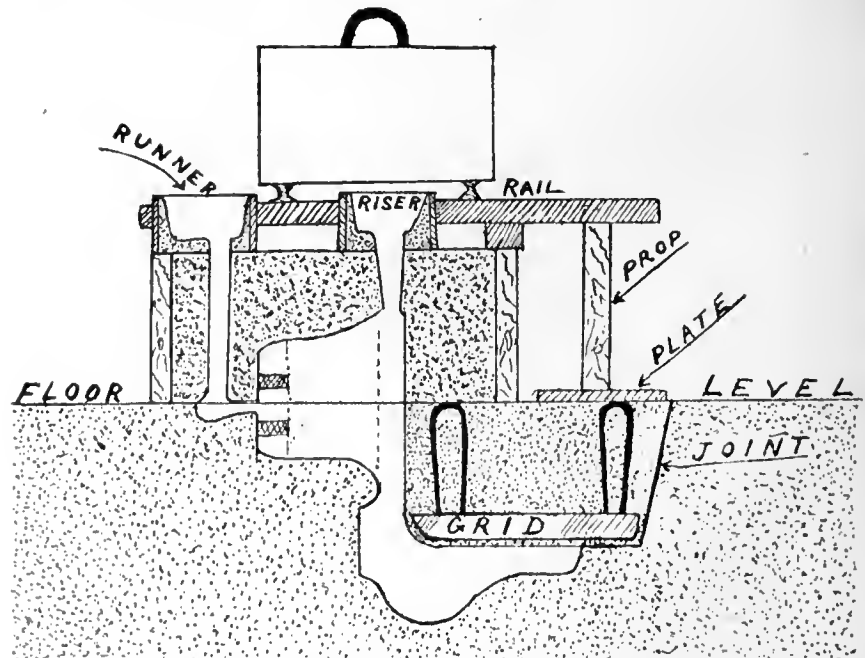

FIG. 4.—MOLDING A FAIR-LEAD.

ation, explaining and illustrating the economies that can be effected from the utilization of "waste" material by the employes of electric light companies. I welcome the opportunity offered me to set forth briefly in the pages of the Bulletin, my ideas on the subject, as well as just a few of the lines along which higher efficiency in the use of material can be secured. The offer of three modest prizes was intended to induce a spirit of emulation and economy on the part of employes, regardless of their posts of duty. The subject is so broad that only a few suggestions are needed to show how economy and utilization may be practised—primarily for the good of the company in which the employe works and obviously for his own benefit because of assured advancement. When it is considered that more than one hundred millions of dollars were obtained in the year 1911 by the simple process of changing into bank funds that commodity flippantly known as "junk," it is evidently necessary for everyone to look to the economical operation of his own work.

The employment of cotton waste is necessary, and it can be used over and over again by a simple method of extracting the oil, either by centrifugal action or by a cheap press, the use of which oil would go towards reducing the lubrication account.

The soot from the stacks that accumulates and is shoveled into barrels and carted to the dump pile is really a high grade of lamp black, even if it is not as deep in color as that for which there is a market at six cents or more per pound. Still the soot can be used in combination with concrete to give a proper or darker tone in laying sidewalks or floors, not taking into consideration its use as a binder in briquetting coal waste.

Used machinists' files, instead of being thrown away or sold as old metal, may be restored by a simple acid bath or recut by the same sand blast which many companies employ for removing old paint from iron structures.

Many janitors, otherwise watchful, fail to recognize the profit in saving accumulations from the waste-paper baskets, old trade publications and catalogues—all of which can be baled and sold to paper mills with but a few inexpensive appliances. Naturally some system must be used to keep the catalogue covers which have been torn from the books separate from the paper, and the letter paper separate from the magazines and trade journals, keeping each class of paper to itself. One or more small forms on which to hang the burlap bags could be made from pieces of 2 by 3 spruce and stood in the corner of the cellar, and when the bags become full they might be laid aside for sale.

This is preferable to allowing ragpickers or paper dealers to come into the factories and mills to cart away the material for the labor of removing it.

Old towels, wiping cloths and similar fabrics might be sold, instead of finding a last resting place in the furnace or underneath the hot water boiler.

Improvements might be made in galvanizing bolts and turnbuckles, which would permit of having the zinc coating inside the nut and on the thread so that nut and bolt would fit snugly.

The oil used in transformers might be bottled after pouring through some straining fabric, and would find ready sale to hardware, dry goods or sewing-machine stores as an inexpensive lubricant.

Scrap Metal.

Often in my negotiations with founders for the disposition of my metal accumulations, which I have no difficulty in selling direct to the users, I am told that my price is too high and that the same class of goods can be obtained from scrap dealers at a lower figure. It is fair to assume that my correspondents are telling the truth and not making the statements with the intention of getting a lower price; therefore, it is obvious that the factories, mills or shops which sell to the scrap dealers are most assuredly not receiving full value in price obtained, perhaps due to carelessness in weighing of the material. This is pertinent because it shows that the accumulations in many shops are considered as junk, that the material is in the way, and must be got rid of, whereas by the process of separating the iron, brass, copper, zinc or such metals as are to be disposed of, one may reach the ultimate buyer, the foundryman, who is willing to pay the difference above what the scrap dealer pays.

As a good deal of economy can be practised in the burning off of lead cable, weatherproof wire, etc., and in the sale direct to metal foundries, it is well to consider even the ashes in which there is more or less copper and lead and for which a good price can be had by selling to refining companies.

A great many other ideas could be set forth, but these will suffice to show how illimitable is the field of economy.

SUGAR REFINERY FOR ST. JOHN, N. B.

CONSTRUCTION work will start early in the spring on a \$3,000,000 sugar refinery at St. John, N.B., to be in operation inside of two years. It is being engineered by the Atlantic Sugar Refineries, Ltd., who have deposited a draft for \$100,000 with the St. John city chamberlain as guarantee that the refinery will be erected.

There will be nine buildings, the refinery proper being a ten-storey structure, 350 feet long by 170 feet wide. The construction will be mainly of concrete and may be faced with brick. To build and equip the refinery will cost in the neighborhood of \$5,000,000.

The proposed refinery will be the largest in Canada, and will employ about 700 men. The sugar will be imported in its raw state from the West Indies, and the open harbor here during the winter will allow the raw material to be brought in by water direct. Mr. Holgate, the refinery engineer, has been in St. John several days recently, completing the work in connection with the location of the foundations. These will have to go down to bed rock, and considerable excavating will be necessary. The agreement with the city of St. John calls for the forfeit of the \$100,000 guarantee if the construction work is not started in the spring, and the terms of the agreement also set a limit on the time when the refinery must be in operation. The capacity of the works will be over 2,500 barrels.

Mr. J. F. Stillman, who has had a wide experience in designing and operating sugar refineries in the United States, has been given complete charge of the planning of the new refinery for the Atlantic Sugar Refineries, Ltd. The incorporators are: Alexander Chase-Casgrain. Errol Creelman McDougall, John Jennings Creelman, and Pierre Francis Casgrain advocates; and Florence Ellen Seymour, stenographer, all of Montreal. Messrs N. B. Stark & Co., of Montreal managed the underwriting and placed the securities.

HEAT INDICATOR FOR BEARINGS.

A NEW heat indicator introduced by General Electric Co., consists of a paint for application to bearings or other parts of machinery and electrical apparatus. It is normally of a bright vermilion, but on reaching a temperature of 120 degs. Fah. shows a change of color, and at 190 deg. to 210 deg. F. is almost black. When the temperature of the part falls below 120 deg. F., the paint resumes its normal red color. It is claimed that the paint is practically indestructible, that it is unaffected by lubricating oils, that it prevents the formation of rust, and that the warning which it gives enables a machine to be stopped before any damage is done by overheating.

There are only two classes in society: those who get more than they earn, and those who earn more than they get.

Features of the "Fulton" Water Cooled Mechanical Stoker

By C.T.R.

At the present time, advance is the watchword in almost every line of human effort, and in no branch of industrial activity is this more true than in that referring particularly to the generation of steam through its foundation and accessory mechanisms. The Fulton stoker here described introduces to our readers a type of mechanical firing apparatus, with whose detail, we believe, more or less unfamiliarity exists, its introduction being, as we understand, new to Canadian steam power generation enterprise.

A NEW stoker has been placed on the Canadian market by the Hare Engineering Co., Ltd., 14 King Street East, Toronto, which is designed on decidedly original lines. While this mechanism, which is known as the Fulton Water-cooled Mechanical Stoker, is new to Canada, it has had a long and successful experience in the United States, and is in use in some of the most prominent plants in that country. It has taken a good many years for the merits of mechanical stoking to be generally recognized by plant owners, even when it is so easy to ascertain the facts in relation to any subject, by consulting engineers, architects and others who have the design of power plants under their care. This is not because stokers have not been able to demonstrate their great superiority over hand firing methods so popular with the uninitiated, but because of the many defects in design which characterized the earlier machines and which resulted in an altogether too high rate of depreciation and repairs, thus lessening to a large extent the saving at first effected. There is absolutely no reason whatever why a mechanical stoker should have a higher rate of depreciation than other machines, such as pumps, condensers, economizers, etc., found in power plants. Although it is often stated that heavy repairs are to be expected with such machines, this view cannot be accepted today in the light of modern improvements.

The Fulton Water-cooled Mechanical Stoker, which has been developed within the last five years, is of the natural draft type. If an engineer had been asked a few years ago if it were possible to carry 100 per cent. overload with a draft pressure of .18 inches water gauge, he would naturally have said that it was not, and that in order to carry such overloads, forced draft must be employed. He would have been quite right then, although decidedly wrong to-day. The development of the Fulton Water-cooled Stoker has not only made it easily possible to carry such heavy overloads with medium and light draft pressures, thereby securing all the flexibility of a forced draft stoker without the expense of operating the auxiliaries, but by a most radical departure from all

other previous designs a system of water-cooling of the parts has been developed which has solved completely the problem of stoker repairs, and has reduced the rate of depreciation to a point hitherto considered impossible. Records of this stoker covering some four years of continuous operation show most remarkable results with regard to economy, capacity and low repairs.

In a large plant in Cleveland one of these stokers, installed under a 466 h.p. Stirling water-tube boiler, was operated

with an efficiency in the neighborhood of 70 per cent., notwithstanding the overloads carried.

Stoker Detail.

The Hopper, as will be seen, extends entirely across the front of the stoker, thus proving a large coal capacity. The back is continuous and provides a stiffener for the hopper independent of the boiler front. The lower side of this back plate is water-cooled, which feature is a distinct advantage in not only

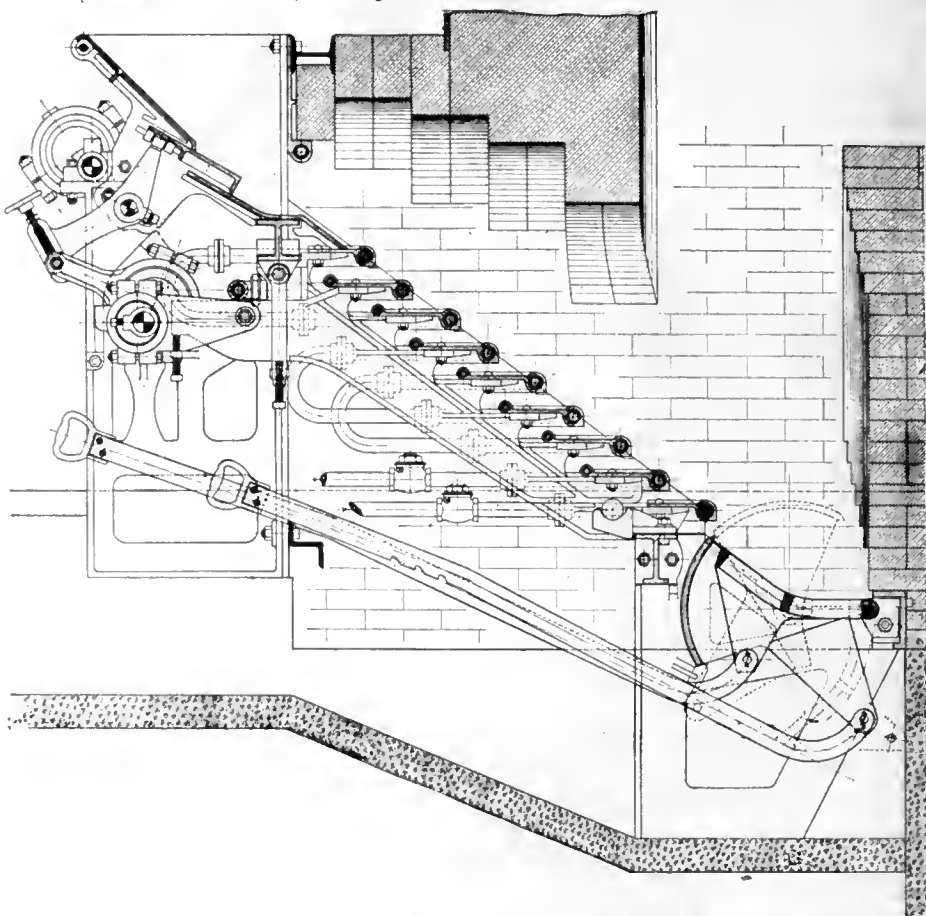

LONGITUDINAL SECTION OF FULTON STOKER.

twenty-four hours per day, seven days per week, for over two months, carrying continuously an overload of 100 per cent., or generating 935 horsepower when burning low-grade slack coal, averaging 12,000 B.t.u. per pound with 3.7 per cent. sulphur. The draft at the grate during this severe trial did not average more than .2 inches water gauge. The Fulton stoker showed an evapora-

tion absolutely preventing the plate from burning out, even after many years continuous use, but, and of no less importance, it keeps the fire from creeping up into the hopper while banked and eliminating trouble from the coal in the hopper fusing into coke masses and interfering with the free action of the coal feeding mechanism. On starting up the stoker when there is no steam in the

boiler to operate the driving engine, the feed slides are always easily operated by hand. These points will be appreciated by engineers generally.

The Coal Feeding Mechanism.

In the bottom of the coal hopper are the coal feeding pushers. These slides

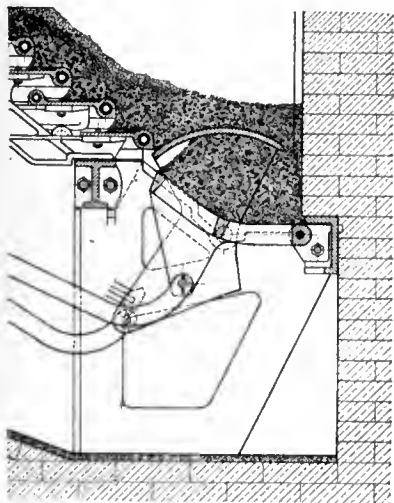

FIG. 1. FIRST MOVEMENT, DUMPING SHIELD PULLED UP.

are so designed that by a simple reciprocating motion the coal is fed from the hopper and pushed over the dead plate to the top grate bar to begin its movement down the grate incline. The actuating mechanism of these slides is extremely simple in detail, and readily adjustable both as to the extent of the movement backward and forward, and also as to the number of movements per minute. All adjustments can be made while the stoker is in operation, yet, once the stoker has been adjusted to suit the extent of the normal load and the

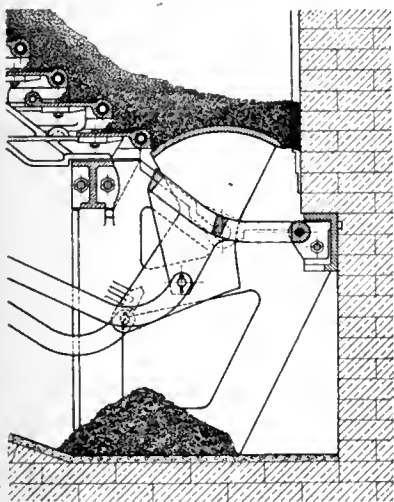

FIG. 2. SECOND MOVEMENT, DUMPING GRATE DROPPED.

character of the fuel to be burned, little attention, it is claimed, becomes necessary.

A feature of the feeding mechanism that is of considerable importance is the employment of a short pusher at

each side of the stoker, capable of independent adjustment from that in the centre. By the adoption of this arrangement it is easily possible to feed the coal at the sides, next the brick side walls somewhat heavier than in the centre, and thus prevent the formation of holes in the fire along the sides, owing to the more active combustion that takes place there due to the radiation from the side walls, and the lower position of the ignition arch.

The Grate System.

The grate surface of this stoker is on an incline of about 35 degs. with the horizontal and is formed of a number of broad flat horizontal plates arranged in an overlapping series of steps, one above the other, from the dead plate which receives the coal from the hopper, to the dump grate at the bottom. These flat grates are all identical in design, but are arranged in two separate banks, moving and fixed, and alternating the one with the other over the entire grate surface. The fixed grates are bolted to the side risers or side frames of the stoker while the moving grates are bolted to moving risers which at their upper ends are connected to the eccentrics on the stoker shaft. Their lower ends are carried on rollers on the frame. This method makes it possible to secure a movement of the bank of moving grates, which, at its upper end is elliptical and at its lower end, approximately a straight line. The number of revolutions of these eccentrics is entirely under the instant control of the fireman, hence while the extent of the horizontal movement is fixed, the rate of feed of the coal along the grates is controlled by varying the speed of the eccentric shaft. While the vertical movement of the eccentric is itself fixed, the similar movement of the grates is modified to suit the different grades of fuel to be burned, and by a very ingenious device, this vertical movement can be varied from nothing to the full movement of the eccentrics. Thus, for a grade of coal of high coking values, the grates may be adjusted to move in an elliptical or a straight line movement forward, and an elliptical movement backward, carrying the moving grates at all times clear of any loose coal or coke which may lie on the rear of the fixed grate below. The action of the grates as described is such as to compel the coal to move forward by a controlled and definite movement, and to any degree of lifting action deemed necessary thus controlling completely not only the action of the burning fuel in the fire but the ash as well from the hopper to the dump grate.

Another advantageous effect gained by this grate movement is the lifting and breaking up of any coke masses that

may form in the fire, thus securing the freest possible passage of air through the fire and facilitating rapid combustion. As the coke and accumulating ash are forced towards the dump grate, the lifting action of the grates becomes less and less until it disappears entirely.

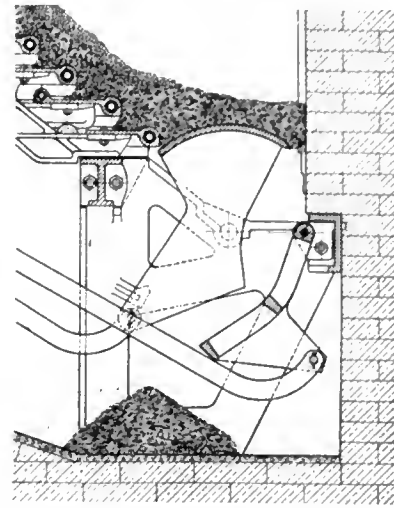

FIG. 3. THIRD MOVEMENT, DUMPING GRATE RAISED.

thereby preventing the formation of air holes in the fire.

By reason of the considerable overlap that exists between each grate and its neighbor, the sifting of fine unburned coal through to the ash pit is absolutely prevented, while the action of the moving grates is such as will push back into the fire any lumps of coal or coke that may work in between the grates. It should be noticed also that this grate movement is secured without alteration in the total extent of air space between the grates.

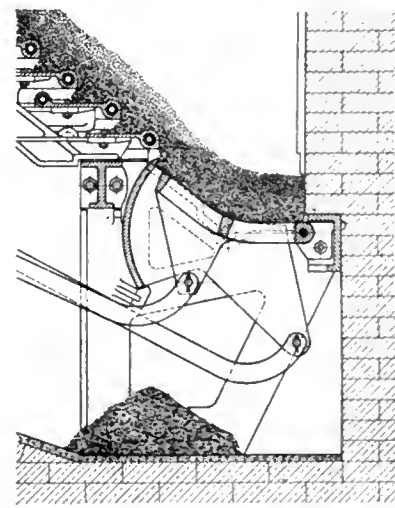

FIG. 4. FOURTH MOVEMENT, SHIELD DROPPED, FIRE CLEANED.

Positive vs. Gravity Feeding.

A consideration of the details of the feeding mechanism of this stoker will show the advantage of the positive feed as compared with the gravity feed. In stokers employing the gravity system of

feeding, the angle of inclination of the grates to the horizontal must be considerable, and in order that the coal be made to move down the incline freely, this angle must be made greater than the angle of rest of slack coal.

The Water-Cooling System.

The one feature by which, this stoker differs materially from others is the water cooling of the grate bar. Each grate bar is water-cooled along the side in contact with the fire, by casting into it a $1\frac{1}{4}$ inch extra strong cold drawn seamless steel tube. This tube is first properly shaped and placed in the mold and the grate bar cast around it. The tubing used in these grates is specially made for this purpose, and is tested to 1,000 lbs. per square inch air pressure under water. The connections between one grate and the next are made through return bends of the same tubing and all connections are made with special bronze to bronze 4-bolt flanged Dart unions, making leaks practically impossible.

Treating the fixed grates as one unit and the moving grates as another, water connection is made direct from the boiler to the lowest grate in each bank and from thence upward from grate to grate until the top is reached, where another connection is made to the boiler above the water line. No flexible joints or hose connections are used in the entire design, and therefore no leaks are possible. The flexibility necessary to permit the action of the moving grates is secured by a free length of the same seamless tubing at the inlet and outlet of the grates, so that the small movement necessary in the grates is provided by the flexibility of the tubing itself.

The circulation of the water through the grates does not depend on the unbalanced condition caused by an increased temperature at one part of the cycle as is the method adopted in almost all steam boilers, for, if this were the case, the tubing in the grates would soon clog up with scale, preventing the flow of the water and rendering the water cooling system useless. This difficulty has been got over by the invention of the flash system which is claimed to be unique with this stoker. Inserted in the individual inlet pipes to the fixed and moving grates are two $1\frac{1}{4}$ inch bronze swing check valves, arranged to open and allow water to pass to the stoker, but to close against any flow in the opposite direction. On the application of heat to the grate bars, the water in the tubes is partly evaporated into steam. The mixture of water and steam thus formed being prevented from discharging downward owing to the action of the check valves, is driven upward through the stoker pip-

ing, and into the boiler. As soon as this discharge takes place, the check valves open and permit more water to enter the stoker pipes from the boiler, when the same violent action is repeated. In normal service, this flashing takes place every 10 or 12 seconds, and is accompanied by sufficient velocity to scour and polish the inside surface of the tubes and thus most effectively prevent scale accumulation. Grate bars cut in two after being in continuous use for four years show an absence of scale.

The Dump Grates.

As will be seen by the accompanying cuts, the ash cleaning device of the Fulton Stoker is extremely simple. It is claimed by this arrangement to separate the ash and clinker from the burning fuel without the usual loss of unburned coke or live coal, while at the same time, preventing the entrance of cold air during the operation of cleaning. The dumping arrangement is not automatic in the sense usually employed, that is to say, it does not grind out clinker ashes or coke as the case may be at all times whether the fire requires cleaning or not, but is so designed that perfect cleaning can be secured when the condition of the fire warrants it, and under conditions that promote the highest possible economy.

It will be noticed that the dump gear consists of two parts, the shield and the dump grate. In the operation of cleaning, the shield is thrown up as in Fig. 1. This cuts into the fire at the point where the ash and clinker accumulate, thus not only preventing the burning fuel from being discharged into the ash pit but by extending across the dump grate to the face of the bridge wall, effectually sealing the ash dump from the entry of cold air while cleaning. The dump grate is next dropped, Fig. 2, carrying with it the ashes and clinker held under the dump shield. It is then returned to normal position, as in Fig. 3. By lowering the shield again, as in Fig. 4, the burning fuel is allowed to flow over the dump grate. In this way, perfect cleaning is secured by a very simple and effective arrangement.

In the many tests that have been made of this stoker the percentage of good coke present in the ash is extremely low and compares very closely to the chemical analysis.

Repairs.

The economy of the Fulton Stoker is shown, perhaps, to better advantage from a consideration of repairs point of view than from any other aspect.

In a plant at Reading, Pa., 1,000 H.P. of these stokers have been in continual

service 16 hours per day for four years, and carrying a large overload. The total repair cost during this time was at the rate of 2.4 cents per horse power per year.



BAD TOOLS MAKE GOOD WORKMEN.

AT a time when practically all the great centres of engineering instruction are naturally proud of their admirable equipment, it may seem hypercritical, or even ridiculous, to question whether much of the expenditure on machines and machine tools does not really react to the detriment of the pupil. However, these things do not stand still. Where there has been expenditure in the past, there will be further expenditure in the future, and I merely ask that some consideration should be given to the views of one who has experience in teaching the elements of engineering subjects, since these views tend to encourage economy in one direction, which would presumably leave more money free for expenditure on other branches, in which it may be that such expenditure would bear better fruit.

The Best Engineer an Opportunist.

The firm belief on which I base my contention is that the best engineers are great opportunists; men who make the most of the appliances at their command, and are not discouraged when they are called upon to carry out a job which appears to be beyond the commonly accepted capabilities of the implements at their disposal. When a tail-shaft breaks in mid-ocean, it is not to be expected that the engineers on board the vessel will have the help of all the ideal appliances for carrying out a repair, but the man who does the thing somehow saves the cost of salvage. When emergencies arise—and an active engineer's life is more or less full of emergencies—they have to be dealt with as best they can at the moment, and under such conditions I would sooner rely upon a man who can keep going an engine which properly belongs to the scrap heap than upon one who fully understands the possibilities of the most complex and marvellous automatic machine tools, and despises whatever is not recognized as representative of modern practice.

Only recently, the principal of a great college of science told me that he had been discussing with a former pupil, who has now made his mark in the engineering world, the value of his scientific training, and had asked what part of his college course had been of most value to him. The reply was that he had learnt most from a casual incident. A member of the staff of the college had occasion

OTIS-FENSOM ELEVATOR COMPANY LIMITED
MANUFACTURERS OF OTIS STANDARD ELEVATORS
 TRADER'S BANK BUILDING TORONTO.
 Toronto, June 23rd, 1908.

ALL AGREEMENTS SUBJECT TO STRIKES ACCIDENTS OR OTHER CAUSES BEYOND OUR CONTROL

The General Fire Equipment Co.,
 72 Queen St. E.,
 Toronto, Ont.

Gentlemen,

We wish to congratulate you upon the satisfactory manner in which you installed your "Non-Corrosive" Sprinkler Equipment in our factory at Hamilton.

The equipment itself has met the requirements of the Fire Underwriters in every respect and has been thoroughly satisfactory to them. But, we wish to say that the manner in which you carried on the work in our factory without hindrance to our business was very pleasing indeed, and also the fact that you, in spite of the difficulties which you met, completed your contract in the time specified.

Yours very truly,
 OTIS-FENSOM ELEVATOR CO. LIMITED
 By *Geo. H. Fensom*
 General Manager

CHF/CH

Since this Letter was written—Four and a Half Years ago—

Manufacturers' Automatic Sprinklers



have paid for their installation by the reduction in Insurance Premiums which they effected.

And in the future, as in the past four years and a half, the Otis-Fensom factory will have absolute protection from fire.

Can you afford to leave your factory unprotected when the most efficient protection in the world will pay for itself?

Write us for full information. Estimates on equipping new and old buildings free.

The General Fire Equipment Co., Limited

72 Queen St. E. TORONTO, CAN.

CAST STEEL CASTINGS

Acid Open Hearth Steel for Locomotive and Machinery Castings.

Stock Process Steel for Automobile and Light Castings of all descriptions.

Prompt Deliveries.
 (Annual Capacity, 12,000 tons.)

Let us figure on your requirements.

The Dominion Steel Castings Company, Limited
 HAMILTON, ONTARIO

to move a power launch between two points overland, and the ingenious means employed to overcome various difficulties of transit as they arose had provided the pupil with ideas which he had successfully translated into action time after time in his subsequent career.

At another place I remember a batch of engineering students being freed from lectures for a couple of days for a somewhat similar purpose. A ten-ton cutter had come ashore, and the owner wished to beach her for repairs on the spot. The shore was very steep, and the coastguards and the local boat builders assured him that the job could not be done. However, it was done, and done satisfactorily, and I think all those who had a hand in it gathered more useful experience than would have come from a month of ordinary workshop practice.

The Test of Real Ability.

For elementary students I am certain that my theory holds good in the main. Almost any boy can work steadily through the construction of a model engine or a small dynamo with thoroughly adequate tools and the guidance of a skilled instructor; but if the tools are imperfect or insufficient in variety, the teaching of the instructor, who is constantly helping him to devise make-shifts, and showing how difficulties can be overcome by ingenuity rather than by improved machinery, becomes far more helpful and inspiring. The doing of the obvious, or the fulfilment of straightforward work that never presents unexpected difficulties, does not make a real engineer. As a matter of fact, I doubt whether the true engineer is not invariably born as such, but mechanical resource, if it exists at all, can, I believe, be "trained on" by facing and overcoming difficulties, and smothered by having all these difficulties wiped out before the pupil realises their existence. Start trained men on straightforward jobs on good machines and all the results will be practically identical; put them on to imperfect machines and give them imperfect tools and you will soon see which are the true engineers. Some will find out what the machines cannot do while some others are making them do it. This quality of achieving the impossible can never be brought out in a shop so perfectly equipped that all things are possible.

Reliable Mechanics vs. the First-Class Engineer.

There is a big difference, over and above that of mathematical and scientific training, between a reliable mechanic and a good engineer. The one is satisfactory enough provided that he carries out well the work entrusted to him on machines suitable for the work. The other

must be always looking ahead and progressing. A combination of high scientific attainments with sound machine shop experience does not necessarily produce a good engineer. What is wanted is a species of instinct; something that tells a man, without conscious reasoning, what ought to be done to improve matters, what is the cause of some trouble, or what will be the result of an experiment not yet tried. Probably every intelligent man has some trace of this instinct, but a first-class engineer has it highly developed. The question is whether this acuteness in mechanical matters is purely a natural attribute, or is capable of being "trained on" to any appreciable extent. If the latter, as I believe, then the young engineer's work should contain unexpected difficulties if it is to be of the greatest possible benefit. Clearly, when he leaves college and goes into works—or if he is on the "sandwich" system during that part of the year when he is employed in works—he cannot have unnecessary pitfalls put in his way without depreciating the value of a commercial product. If this sort of thing is to be done at all it must be done in the college course. If inferior or faulty tools are to be used deliberately it must be upon work on the perfection of which no made reputations depend.

College Equipment Suggestions.

What I should like to see is something in the nature of a pause in the improvement of some parts of the equipment of technical colleges. The tools and machines which go out of date or become faulty and inaccurate under the handling of many beginners, instead of being sold off at scrap prices, might be gathered in a shop specially set apart for them, and in that shop all engineering students should spend some part of their time. The work which they did there, together with particulars of their difficulties and the assistance given to them, would be kept quite separate from their work done in the properly equipped machine shop, and I think ought to be taken into full account in estimating progress and in examination results. It would be helpful, too, in enabling teachers to advise their students as to the branches of the profession best suited to their abilities. It would be found that some men would do astonishingly fine work under bad conditions and yet would not shine elsewhere. Again, students of an almost ideal character, quick and accurate in theoretical work, reliable in practical work, would be found not to possess the curious faculty of getting good from bad, and would be saved from wasting themselves on branches of engineering in which the exercise of this faculty plays a particularly important part.

I should like, also, to see some old—preferably badly designed and badly handled—engines and electrical equipment kept and used in somewhat the same way. Much may be taught from these "awful examples." I well remember one which did excellent service to many generations of engineering students. It was a single-cylinder horizontal steam engine, supplied through about 50 feet of unlagged steam pipe by an antique Scotch boiler working at a painfully low pressure. The steam pipe descended about 12 feet vertically into the steam chest, and the exhaust pipe rose vertically through the roof into the open air. The "swashing" of water could be distinctly heard whenever the engine was at work, and I imagine that a cover would have gone very quickly if the piston and D valve had fitted properly. The comparison of diagrams taken from that engine with those from a modern set in the same shop was very instructive, and it and its boiler were continually useful in showing how things should not be made or fitted up.

Perhaps I am carrying a somewhat revolutionary suggestion rather too far, for I admit that the "handy man" is not the only variety of engineer, and it is the "handy man" who would probably do best in such surroundings. Even so, a very big percentage of engineers still find their greatest asset in resource. If a man has been given a thousand a year at the university, he cannot be expected to settle down very contentedly on the \$12 a week that he subsequently earns, and if an engineering student has been accustomed to having at hand the ideal implement for every job he does, he will be equally helpless if he has to face rough and ready work under difficulties. Moreover, it is only by comparison that we learn to appreciate what is good when we get it, and at the same time to realise that even good may be made better by the application of sufficient knowledge or ingenuity.—From a contribution by "Hastatus" in the "Arena" monthly.



The Pollard Mfg. Co., Niagara Falls, Ont., in addition to their original line of stone and marble working machinery, are now manufacturing small hand-power and electrically driven traveling cranes, electric hoists and heavy steel derricks. Job casting work is also being undertaken, their foundry capacity being such as to secure large, heavy and reliable castings on short notice. Messrs. E. T. Pollard and William La Bombard, president and secretary-treasurer, respectively, were, for 10 years, associated with the F. R. Patch Mfg. Co., Rutland, Vt., makers of similar machinery.



PRESENT HARBOR, ST. JOHN, N.B., FROM EAST SIDE.

Industrial Development of the Maritime Provinces

By J. B. Dever

When we stop to consider the mineral wealth of New Brunswick and Nova Scotia, and take account of their location relative to harbors and ports for the export and import of the product of mill and factory, there is a natural disposition to assume that a higher degree of achievement in industrial enterprise should have been theirs in the past. Be that as it may, the record of progress and development shown in this article, indicates forcibly a realization, now, of possibilities to be grasped.

A NEW era has dawned in the industrial development of the Maritime Provinces of Canada. It is an era of progress and prosperity, and the situation has not been confined to one centre alone in the rapid strides onward, but is most pleasingly general. There is a changed feeling among the people—a spirit of optimism prevails, and after a visit to the scenes of various activities, it is not difficult to find the motive, for industrial expansion, agricultural progress, financial enterprise, transportation extensions, government and private developments and other important issues are all prime factors in contributing to the healthy and rapid growth. St. John, Halifax, Moncton, Amherst, Sydney, New Glasgow, Charlottetown, are each experiencing the same lively onward movement, but the strongest features in the underlying reasons for the optimism of the people are the new industries coming to St. John together with the government developments, the fact that the government is providing for the establishment of more material expansion at Halifax, and the knowledge that new industries are being created in the other centres of the provinces as well. The outstanding harbingers of future possibilities are the port developments of the two leading cities, St. John and Halifax.

Without prolonging this article to too great a length, it would be impossible to describe the various activities in the industrial world in the leading maritime centres. It would require another or more chapters to tell appropriately of what is going on in the way of new in-

dustrial projects being established, but in this article the endeavor will be to present a fleetly sketch of what is transpiring in the Atlantic provinces to create the re-awakening which has occurred, and to permit of this section being known in trade and commerce circles, collectively speaking, as "The Busy East."

St. John, N.B. Harbor and Docks.

In St. John the change which has taken place recently, is quite remarkable. It practically began when the news became definite that the government would make at Courtenay Bay a new harbor in addition to the magnificent, all-the-year-open one, which has been the envy of other large cities for many years. The Grand Trunk Pacific purchased a site for terminals on what was then but barren lands, and closely following this came the announcement that The Norton Griffiths Co., Ltd., were to build a dry-dock, breakwater, and wharves, and also to dredge a harbor sufficient for deep-sea steamers. One of the chief officials of this latter company has made the cheerful announcement, based on practical knowledge and experience, that the city affords a splendid site for a steel plant. The work of the Norton Griffiths Co. is being proceeded with in a manner never expected. They are living up to their name as progressive contractors, and the stupendous task awarded them, calling for the expenditure of eleven and a half millions of dollars is going along in most commendable style, although it will take fully five years for its completion. W. Burton Stewart, general manager of the

big English concern has announced that he will use his every endeavor to bring to St. John a steel and iron industry, and it is currently whispered that the Drummonds are interested in the movement as well. A short time ago, one of that illustrious name in the history of steel and iron expansion in Canada, was in St. John and had a conference with the mayor and commissioners, and it was freely stated after the meeting, which was private, that the matter under discussion was the projected establishment of such an industry. It is now said that the greater hulk of capital for the scheme has been subscribed.

The Canadian Pacific Railway, purchasing further land at west St. John, has begun the erecting of a million bushel elevator in addition to the other two now in the city. The J. D. Metcalfe Co. are working upon this contract and the work is being well pushed along. The T. S. Simms Co. are moving from their old brush factory in Union street to one decidedly more up-to-date in Lancaster which is now practically completed, the construction having been attended to by the Aberthaw Construction Co. The machinery for this great plant, which will have a much greater capacity than the former building, is being installed, and it is superior to that in many brush or broom factories in some of the large centers.

The Canada Brush Co. was organized early in the year and was meeting with distinct success in their output of stock until fire devastated their factory, and it looked for at time as though the city

might be deprived of what was a most promising industrial plant. Plans are now under way, however, whereby the company will proceed with even greater expansion, and they are finding all they can do in temporary quarters to fill the orders which are coming their way. The Maritime Car Co., another new concern, have wrought wonders at Coldbrook, having constructed a suite of fine buildings for the construction of automobiles, trucks, etc., and this is another industry which is expected to prove a distinct boon to St. John and the locality effected. It is thought that they will be shipping cars early in the spring. The firm of T. McAvity & Sons have found business so satisfactory that their present quarters are becoming too small for them, large even though they be, and they are

are particularly favorable to textile industries. The capacity of the York and Cornwall cotton mills is to be increased and employment given to more people. This work is to be proceeded with immediately. Although the plant of the John E. Wilson Machine works was destroyed by fire some months ago, it is the intention to rebuild, and the matter is now receiving the earnest consideration of those connected therewith. With industrial and manufacturing establishments of long years' standing in St. John, and those which have been in existence from only recent date, the past year has been one of remarkable activity and prosperity. There is a wider market opening for products, and these are finding their way to the most remote corners of the continent. With the birth of the

Moncton's industrial concerns have had a good year, and are looking forward with bright hopes to the future. A new line of railway has been opened through fertile districts from that city to Edmonton, and more than ever is the name of "the railway city of the Maritime Provinces" deservedly applied to Moncton. Among the new projects being considered is the possibility of an English concern starting an automobile factory with a capital of \$600,000, and the erection of a new woollen mill. There is also the organization of the "Provincial Clay Products" with a capital of \$200,000, to manufacture drain pipe and other materials from an excellent bed of clay discovered adjacent to the city.

Chamcook N.B.

There is a new town on the map of New Brunswick. It has made its appearance within the past year, and now has quite a promising population. The name of the town is Chamcook and it is located in Charlotte county. Its presence has been made possible by the erection by the Canadian Sardine Co., of a splendid new factory there, and like magic, the buildings of the factory, dwelling houses, stores, etc. have sprung up. In all there are about five or six hundred people in Chamcook now, and this is most cheerful, considering that it was but a stretch of barren seashore only a few months ago.

Grand Falls, N.B.

The possibility of harnessing the enormous flow of water at Grand Falls, N.B., has long been a matter of discussion and interest with capitalists, but it now seems as though the project were assuming more definite proportions, as though it had developed something more than talk. A company has been organized in which Sir William Van Horne and others are interested, and a settlement of claims between it and a rival concern, each aiming at possession of similar power rights, will probably result in the successful harnessing of the water power. Premier Fleming gave it as his opinion some time ago that within three years there would be pulp and paper mills at these falls and there is now strong talk of a saw mill and pulp mill being erected by the company to which reference has been made. Bathurst is another place at which it is said there is reason to expect a harnessing of water power for similar purposes.

Fredericton, N.B.

Fredericton, the capital of New Brunswick, is not being neglected in its share of industrial prosperity, and the same may be said of the concerns at Woodstock. In the capital, within the past



BEACON LIGHT AT HARBOR ENTRANCE, ST. JOHN, N.B.

only awaiting for a convenient site about the city to assemble all their plant in one place, giving employment in their brass finishing, moulding, and machine shop to nearly one thousand hands.

There has also been organized the Atlantic Sugar Refineries, Limited, with bright promises, and F. H. Anson, general manager of this concern, only recently deposited with the city the sum of \$100,000 as a guarantee of good faith that the construction of one of the most modern sugar refineries in the world will be commenced, the buildings for which, with the necessary equipment will aggregate about \$300,000. J. C. Burton, of Vancouver, B. C. was in St. John early in December, and was so favorably impressed with its opportunities for industrial enterprise, that he decided to open a branch of the firm with which he is connected, namely, the A. J. Burton Saw Co. They have another plant in Ottawa and their main plant is in Vancouver. They will also establish a branch at Oxford, N. S.

The climatic conditions of St. John

New Year some firms are even now planning still further expansion and the installation of more modern equipment in their shops.

Moncton, N. B.

St. John is not alone in the enjoyment of prosperity. Moncton, for instance has been booming along with encouraging strides, with the various manufacturing concerns experiencing a healthy condition of affairs. The discovery of natural gas has proven a great blessing, and the majority of the industrial and business houses are finding it advantageous and cheap to use. Natural gas and electric power properties are to be developed on a larger scale than formerly, and a prosperous future is predicted in this regard. There is every reason to believe that within a shorter time than people may think, there will be a pipe line from Moncton to St. John carrying natural gas. When this is accomplished, as it undoubtedly will be, judging from the interest displayed in the project, it will create a still livelier impetus in the growth of both places

year, there has been much expansion in the factories of the shoe companies, and two new packing factories have been erected. The cotton mill at St. Mary's is to be further enlarged and this is generally taken as a most forcible sign of prosperity. Campbellton, rebuilt on broader lines, has arisen from its ashes, and there is little now left to remind one that only a few years ago the whole town was devastated by flames.

Amherst, N.S.

Passing from New Brunswick to the sister province of Nova Scotia, the city of Amherst naturally suggests itself as a centre wherein manufacturing and industrial conditions had attained a high degree of success, and this is plainly evident from a visit to this bustling township. The Rhodes, Curry Co. have been greeted with encouragement to a great extent, and the Malleable Iron Works have found things so promising that they decided it was time for further expansion of their plant. Christie Bros. & Co., have also added to their plant. The Nova Scotia Carriage Co., manufacturing carriages and automobiles, are now established in Amherst and find themselves with plenty of good business at hand.

New Glasgow, N.S.

New Glasgow is naturally located for budding into a big industrial city. It is in the centre of a thriving community, being united by electric train service, with the bustling mining towns of Westville and Stellarton, and within a short radius of its centre reside fully 20,000 people. The erection of the Eastern Car Company's shops and works has proven a wonderful boon for the city, and will probably mean the introduction of new industrial establishments. The McNeills and the Brown Machine Co., both of New Glasgow attended to the contract work, which was enormous. Many of the men behind this concern are members of the Nova Scotia Steel & Coal Co., which has met with success at New Glasgow, and they have organized for the construction of steel freight cars, with a capital of \$2,500,000. The other industries are also prospering and have had a splendid year. One of the recent acquisitions to the industrial life of Truro is the formation of the Canada Cap Co., which will afford employment to quite a number of hands.

Sydney and Glace Bay.

Sydney and Glace Bay would scarcely be recognizable to-day as the same centres they were even a couple of short years ago. The mining, steel and coal industries there, are in a flourishing state, enlarging their output every year, and making valuable and important ad-

ditions to their plant and equipment. The fertilizer works at Sydney are among the more recent of those which have found the need of enlargement. This new concern has met with much success in the manufacture of mixed fertilizer, and among the plans for the expansion is a provision for the erection of a large factory.

Halifax, N.S.

Evidences of industrial progress in Halifax are not difficult to find. They are plainly visible in the encouraging state in which the industries of the city are found. The expenditure of \$20,000,000 by the government on terminal facilities and in the construction of wharves to cope with the increased steamship traffic is an important event, and is evidence of the valuable position occupied by the city in this regard from a federal, or really national standpoint. The increasing of the size of the dry dock to provide greater accommodation will eat up another million dollars and the same may be said concerning the immigration facilities. It is also currently reported in the city that another million will be expended on improving the fortifications there. Undismayed by the fact that they were heavy losers in the fire which swept their plant at Woodside last February, the Acadia Sugar Refining Co. are rebuilding at a cost of about \$1,200,000 on the same site, the contract being given to S. M. Brookfield, Ltd. The company has every reason to believe in the future, and was doing a splendid business when the fire devastated their holdings. The new buildings and equipment will be much superior to the old.

Many of the larger manufacturing firms are finding it necessary to enlarge plants for the purpose of coping with the rush of business. Two of them alone, with this object in view, are making additions and changes which will require an outlay of \$100,000. The city council has decided upon the building of an incinerating plant which will cost in the vicinity of \$50,000. The tram companies finding business rapidly growing, have spent \$100,000 in extending their service and double-tracking certain sections.

These are but a few of the many important factors in the commercial life of Halifax, and at a rough estimate it is figured that nearly \$30,000,000 has been spent during the past year or will be in the near future in different projects, enlarging the scope of some, erecting others, and in general expansion along the lines indicated, or in building operations. Halifaxians as a rule do not shout much, but these figures stand for something of this nature. The govern-

ment expenditures on the erection of about a mile and a half of docks will naturally bring other industries and create a new situation with regard to civic progress. It will mean greater activities in various ways, and it is not at all unlikely that within the course of a few years there will be established large ship-building works.

General.

After all that has been said, is it not reasonable to say that Canada's East has come into its own? Is it not apparent—the reason for the feelings of the people of the Maritime Provinces being so strongly optimistic of the future? On every hand are evidences of growth, and it is a healthy and continued growth which will not die in a given time. It has come to stay and will expand even to greater dimensions within the next five or ten years, until such cities as St. John, Halifax, Moncton, New Glasgow, Sydney, Fredericton and others are the centres of a wealth of progressive industry, metropolitan in their composition, and advancing steadily to the foremost ranks amongst the leading cities not only of Canada but of the long line of territory touching upon the broad Atlantic. More industries are coming, that is certain. The boom which is now being experienced in St. John and Halifax more particularly than in other cities, is certain to extend its influence over a greater stretch of country, until the surrounding suburbs are embraced within the confines of those two great seaports, and the advent of the next decade will see them prominently noted each as a leading metropolis of Canada, taking rank with the foremost on the map.

WIRE AND NAIL PLANT INCREASE.

PRESIDENT Plummer, of the Dominion Steel Corporation, reports that additional machinery to increase the capacity of their wire and nail plants, which have recently been doing double turns, has been ordered. This will give at once an output of over 2,000 kegs daily, and ultimately provide an outlet for the whole of the product of the wire rod mills. The company is arranging for a distributing centre at the head of the lakes, where they may, in addition, put in a small nail mill to facilitate their North-West business. It is the intention, however, to concentrate the manufacturing business as much as possible at Sydney.

F. John Bell, formerly general manager of the British Canadian Power Co., Cobalt, Ont., has been appointed general manager of the Canada Wire & Cable Co., Toronto.

STEAM-HYDRAULIC FORGING PRESSES.

MAKERS and users of heavy forgings are generally ready to concede that press work is better than hammer work, unless the hammer be made of unwieldy proportions, and, wherever we turn, we find the latter being replaced by presses. The reasons are well

known. Hammers, unless excessively heavy, work on the outside of the piece and leave the inside spongy, whereas, the slow pressure of the press treats inside and outside alike. Furthermore, heavy

hammers require large and costly foundations, and even then their efficiency is far from perfect, because a large portion of the energy of the blow is dissipated in vibrations of foundation and soil. While hydraulic accumulator presses have been in use on this continent for several decades, the steam-hydraulic or direct acting intensifier press is of rather recent origin and has been developed in Europe. Its success on the other side of the Atlantic has caused several American firms to take up its manufacture, and the Mesta Machine Co., of Pittsburgh, have introduced a design which, in accessibility and straightness of force action, equals or even surpasses the steam hammer. The press in question was originated by the firm of Haniel & Lueg, of Dusseldorf, Germany, and the exclusive right for building in the United States and Canada was acquired, two years ago, by the Mesta Machine Company, together with a large amount of engineering and manufacturing information relative thereto.

pistons of the steam cylinders (r) are connected to the extension of piston rods (g). The air chamber (w) is partly filled with water and is connected to hydraulic cylinder (p), with check valve (v) in the connecting pipe. The bal-

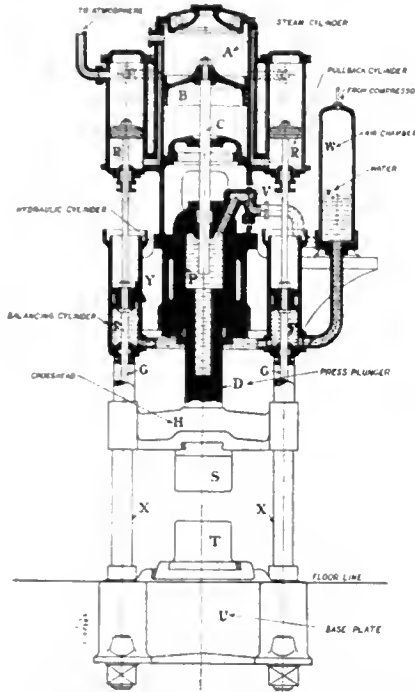

FIG. 2. SECTIONAL DRAWING OF MESTA-HANIEL & LUEG PRESS.

Fig. 1 shows two of the presses built by the Mesta Machine Co. for general forging purposes. The operating lever for the large press is shown at the left of the picture, and it will be noticed that it is accessible from all sides for the use of shear tools, die holders, etc. Fig. 2 shows a front elevation with sectional view of the cylinders. The press consists of a heavy base (u), four columns (x), and the stationary cross-head (y), which contains hydraulic cylinder (p) and hydraulic balancing cylinders (f). The pistons of the balancing cylinders (f) are connected to the movable cross-head (h) by the piston rods (g). The

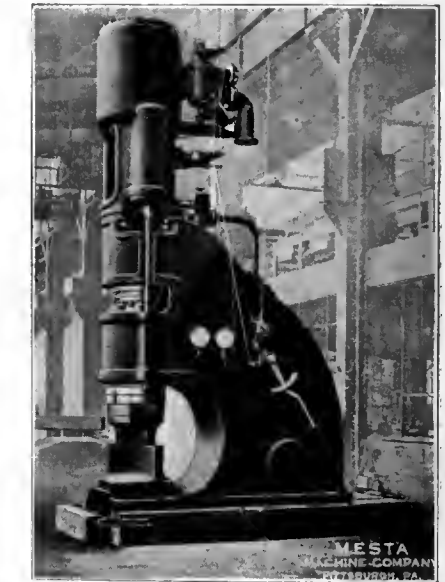

FIG. 3. MESTA-HANIEL & LUEG PRESS. BUILT FOR BROOKLYN NAVY YARDS.

ancing cylinders (f) are connected directly to the air chamber. The single-acting steam cylinder is seen at (a), while (t) and (s) are the top and bottom dies.

Hydraulic cylinder (p) balancing cylinders (f) and about one-third of air chamber (w) are filled with water. The air chamber is then pumped up to a pressure of about 100 pounds, which is sufficient to move piston rod (c) and piston

known. Hammers, unless excessively heavy, work on the outside of the piece and leave the inside spongy, whereas, the slow pressure of the press treats inside and outside alike. Furthermore, heavy

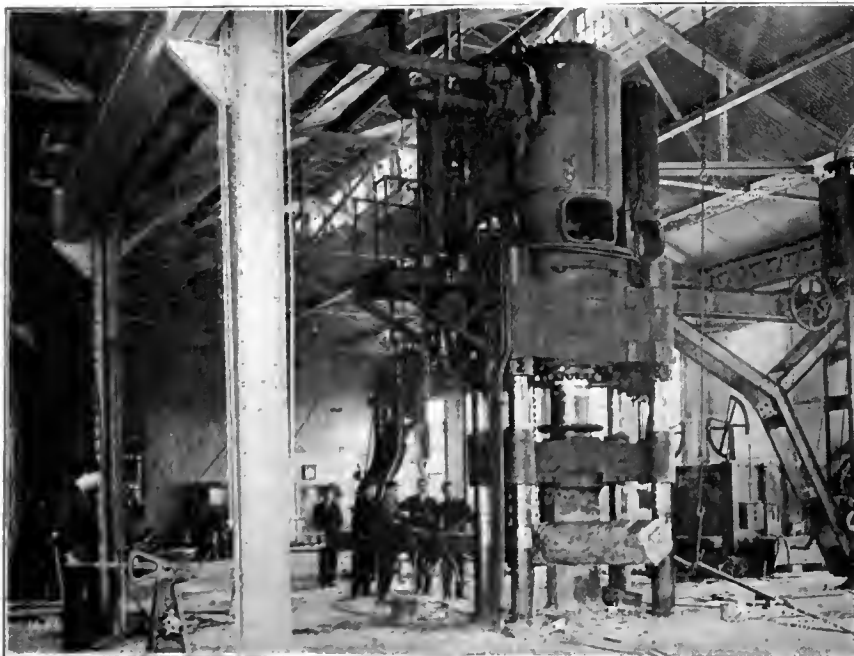

FIG. 1. 500 TON MESTA-HANIEL & LUEG PRESS AT WORK IN FORGE SHOP.

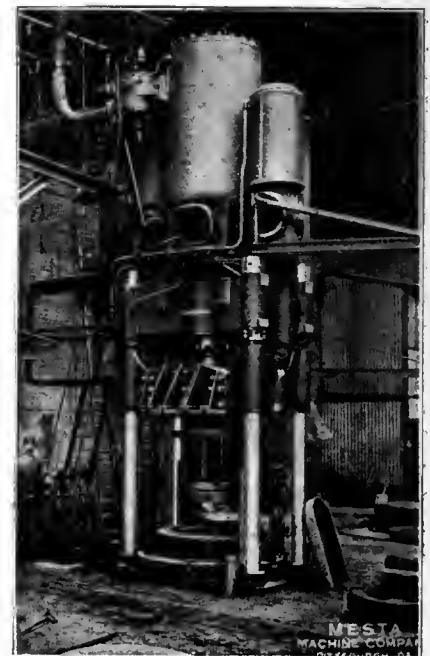

FIG. 4. MESTA-HANIEL & LUEG BENDING PRESS FOR BOILER HEADS AND FLANGING WORK.

(b) to the top of steam cylinder (a), when there is no pressure in the latter. The pressure on plunger (d) is always balanced, as the area of the two cylinders (f) is equal to the area of cylinder (p). By admitting steam to cylinders (r) the cross-head (h) which contains die (s) can be moved upward to any point by lifting check valve (v) and allowing water from cylinder (p) to flow into air chamber (w). When die (s) is at the proper height, check valve (v) is closed, and the press is then ready to take the piece to be forged between the dies (s) and (t). By admitting steam to cylinder (a), piston rod (c) is forced into cylinder (p), which gives the necessary pressure to do the forging. As soon as the steam is exhausted from cylinder (a), piston (b) and cross-head (h) automatically move their positions ready for the next stroke.

Press Features.

The all around accessibility of the press and the small requirement of floor

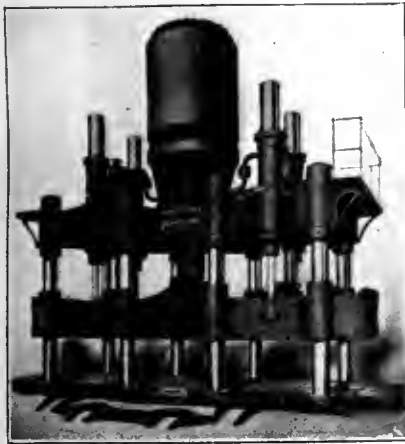

FIG. 5. MESTA-HANIEL & LUEG BENDING PRESS FOR CAR FRAMES.

space is coupled with a slightly greater requirement for head room. The word "slightly" is used on purpose, because on presses which place the steam intensifier on the floor, the pull back and balancing cylinders take up considerable head room which is only very little increased in the Mesta press by the central intensifier. A glance at figures 1 and 2 proves the correctness of this contention. The accessibility is also exemplified by Fig. 3, which represents a press built for the Brooklyn Navy Yard. It shows the press and intensifier complete, the whole in outward appearance, resembling a steam hammer, without its objectionable features, namely, vibration and costly foundations. The press-frames are self-contained, so that it can sit on beams if necessary. Fig. 3 also shows a linkage system (above the frame) for the purpose of making the motion of the upper press die follow the

motion of the operator's hand. This linkage offers the additional advantage that it makes use of whatever inertia there may be in the moving parts for obtaining steam economy by expansion.

It has long been realized that the hammer is out of the race in flanging processes, and for this purpose, presses are in general use. Here the survival of the fittest and the trend toward simplicity and direct action open a wide field to the steam hydraulic press. Fig. 4 shows a flanging press (Mesta-Haniel & Lueg system) with steam and pull back cylinders, and Fig. 5 shows a steam hydraulic press of the Mesta-Haniel & Lueg type for flanging car frames. This type of press can be adapted to many other uses.

COAL VERSUS OIL.

IN the course of his annual memorandum, Mr. C. E. Stromeyer, the chief engineer to the Manchester Steam Users' Association, gives some notes on the use of oil as fuel, as well as on the question of oil and gas in internal-combustion engines.

He remarks that it is difficult to make a comparison of prices, for according to quality and locality the value of coal varies from, say, less than \$2.50 for slack near the colliery to well over \$5.00 for good coal in towns.

Advantages of Oil Firing.

Two very important advantages of oil firing are the ease with which it can be regulated, and the absence of ashes and clinker; on the other hand, oil must be burnt in brick-lined combustion chambers, which suffer severely from the intense heat and have to be frequently repaired and renewed. If these brick chambers are built into the furnace flues, they have to be pulled out annually in compliance with the Factory and Workshops Act.

During the recent coal strike in England, many steam users fitted sprayers to their furnaces, which delivered the oil upon the bed of coal on the grate. Generally the results were as satisfactory as could be expected, but there were quite a number of gas explosions in the flues. These were due to the escape of unburnt oil which had become vaporized in the warm flues and was there mixed with air; any spark which might stray to a remote corner of the flue where this explosive mixture had formed would ignite it.

Internal-Combustion Engines.

Roughly stated, a first-class modern steam engine utilizes about 12 per cent. of the available heat in the coal, resulting in, say 1.6 lb. to 1.7 lb. of fuel per

b.h.p. per hour during a week's work of 55 hours. If the boilers are to be fired by producer gas, for which purpose slack and dust can be used, then each b. h.p. will require about 2 lb. to 2.2 lb. of coal. Internally-fired gas and oil engines are approximately twice as efficient as steam engines, which means that they utilize about 25 per cent. of the available heat.

Crude oil being 37 per cent. better than good ordinary coal, oil engines should use only about three-eighths of the quantities of coal mentioned above, say about 0.6 lb. per B.h.p. Then, however, as there are no boiler radiation losses over night, a material saving results, and the oil consumption per week of 55 hours may be about 0.5 lb. per B. h.p. Petrol and similar internal-combustion engines would require about 0.4 lb. per B.h.p. Gas engines have also about the same efficiency as oil engines; but as there is a loss of about 20 per cent. in the producers, if these work day and night, and another loss of quite 10 per cent. if they have to stand idle overnight, the efficiency of gas engines is only about 40 per cent. better than that of first-class steam engines.

Fuel Cost Relationship.

The following table shows the relationship of prices of the various fuels, each column giving those prices at which equal economy would be achieved if any of the power processes mentioned are used:—

Crude oil, per ton	\$9.00	\$10.00	\$11.00	\$12.50	\$14.00	\$15.00
Crude oil, per gal.	3.5c	4c	4.5c	5c	5.5c	6c
Good coal, per ton	6.50	7.50	8.50	9.50	10.25	11.25

Thus, at present, it would cost just about as much to use a Diesel engine, as a steam engine, but in remote districts the Diesel engine would probably show to advantage. Petrol engines are, of course out of the question from an economical point of view, for the present price of petrol is quite three times as high as that mentioned above. It ought to be profitable to work internal-combustion gas engines, for although gas producers can be fed with very cheap fuel, the above list shows a profit even when paying 15 per cent. more than for steam coal. The reason why these engines are not used as much as might be expected is that they are not self-contained like oil engines, but are hampered with costly and troublesome gas producers. In order to reduce this nuisance, gas might be produced at central stations and supplied through pipes to gas engines at the works; but that means that factories would have to cluster themselves together, which is against the present tendency, and way-leaves for large pipes would have to be obtained.

INCREASED LOCOMOTIVE EFFICIENCY FROM CHEMICALLY TREATED WATER.

THE Committee Report of the Traveling Engineers' Association states that the use of soda ash in the tank in the proportion of about 1 pound per 1,000 gallons, the use of caustic soda in smaller proportions, and also the water-treating plants, have all met with success so far as scale formation is concerned. In connection with the graphite, luminator and crude oil treatments, the committee has no information of any beneficial results having been obtained.

One complete report was submitted in reply to the request for the cost of treating feed-water. This was from the Santa Fe. The accompanying table gives the average costs for the different divisions:

The conclusions from the answers to the questions in connection with the

ber, 1907, each of these locomotives had received a new fire box, six of them had received three sets of flues, and the other two, two sets; the average mileage of all fire boxes was 66,064, the lowest 62,452, and the highest 81,608. The average mileage per set of flues during this period was 25,167. There are mountain grades on which helpers are used. The work performed by these engines is heavy fast passenger service, and a very large part of the division is 1 per cent. grade. Shortly after these engines received new fire boxes, or in the latter part of 1907 and the beginning of 1908, a number of water-treating plants were installed, and three other plants were installed in 1910, consequently some of the locomotives made considerable mileage with the second fire-box before the installation of the water-treating plants was completed. There are no serious defects in these boxes as yet, and they

tion, and enabling us to handle tonnage that it would be impossible to handle otherwise. In territories where the water is not bad enough to warrant the installation of treating plants, but does give trouble with foaming, we find that anti-foaming preparations have a favorable effect in preventing incrustation as well. It is but just and fair to a water treatment that counteracts or prevents foaming, to give it credit for adding to the life of the fire-box and flues, on the theory that when it prevents foaming it keeps the water in a more dense condition, so that it absorbs more readily the heat that is passing through them, and by so doing prevents their overheating and consequent damage.

General Conclusions.

Other conclusions, reached by the committee were that treated water increases the tendency to foam; that anti-foaming chemicals are successful; that treated water does not increase the mileage between washouts; that the efficiency of the locomotive is increased by the use of treated water, especially if used in connection with an anti-foaming treatment; that the increased foaming of waters treated for scale increases the cost of maintenance of the locomotive; that blow-off cocks should be freely applied and used, that their operation should be convenient and that the frequent use of blow-off cocks for short intervals is better than longer openings at long intervals. The committee stated that soda ash is beneficial in waters where the encrusting solids are heavy and the alkali salts light.

COST OF TREATING WATER ON THE SANTA FE.

Station—	Before Treat.	Grains of Incrustants.		Per 1,000 Gals.	Cost Per 1,000 Gals.	Total lbs. Incrustants Removed.
		After Treat.	Removed.			
Illinois Division	29.2	3.6	25.6	3.65	.0313	972,193
Missouri Division	25.7	4.4	21.3	3.04	.0210	470,463
Kansas City Division	20.7	4.8	15.9	2.27	.0230	595,491
Eastern Division	28.4	4.0	24.4	3.48	.0282	1,073,922
Middle Division	36.9	4.3	32.6	4.65	.0144	1,100,951
Oklahoma Division	34.3	4.3	30.0	4.28	.0319	808,954
All Eastern Lines	30.8	4.2	26.6	3.80	.0298	5,021,674
Western Division	33.8	2.9	30.9	4.41	.0425	654,506
Arkansas River Division	52.4	3.6	48.8	6.97	.0553	1,596,271
Colorado Division	47.8	3.5	44.3	6.32	.0231	894,667
New Mexico Division	42.9	4.3	38.6	5.51	.0186	1,006,514
Rio Grande Division	24.3	4.1	20.2	2.88	.0311	648,573
Pan Handle Division	42.4	3.3	39.1	5.58	.0432	427,695
Plains Division	31.4	4.2	27.2	3.88	.0182	41,883
Pecos Division	39.2	3.8	35.4	5.05	.0611	956,886
All Western Lines	38.9	3.7	35.2	5.02	.0375	6,226,995
A., T. & S. F. Proper	34.9	3.9	31.0	4.42	.0336	11,248,669
Albuquerque Division	34.1	4.2	29.9	4.27	.0393	1,152,635
Arizona Division	25.0	3.2	21.8	3.11	.0257	1,271,690
Los Angeles Division	23.6	2.5	21.1	3.01	.0274	1,042,723
Valley Division	22.6	2.9	19.7	2.81	.0261	171,916
Coast Lines	26.3	3.2	23.1	3.30	.0297	3,638,944
A., T. & S. F. System:						
1911	30.6	3.5	27.1	3.87	.0324	14,887,633
1910	31.6	3.6	28.0	4.00	.0318	15,284,164
1909	35.4	3.7	31.7	4.52	.0332	13,063,320
1908	35.8	3.9	31.9	4.55	.0346	11,102,859
1907	32.6	4.3	28.3	4.03	.0355	9,579,772
1906	35.0	4.1	30.9	4.41	.0361	7,906,233

OPENING OF THE TRANSCONA SHOPS.

ALTHOUGH the question of whether the Transcona shops do or do not form an integral part of the National Transcontinental Railway is still under arbitration, a temporary agreement was recently come to between the Government and the Grand Trunk Pacific Railway, by which the latter commenced operation of the locomotive shops on Jan. 20th. Mr. G. W. Robb, Master Mechanic, G. T. P. R., has been busily engaged in organizing a working force, the men being drafted from Rivers, Man., and other divisional points. It will, of course, take some little time to gather a full mechanical staff, but the G.T.P. hope to be able to soon get together some 400 or 500 men. Raw material necessary for locomotive repairs is being rushed to Transcona as rapidly as possible and work on a small scale has already commenced.

The opening of the shops has given quite an impetus to the town of Transcona, which had long been anxiously awaiting the event.

mileage of flues and fire-boxes before and after treatment of feed-water show that an increase in mileage of from 78 per cent. to 150 per cent. is being obtained where the water is handled in treating plants. Equally good results followed the use of anti-scale chemicals in the tenders. The following is the report of the Santa Fe on this feature:—

Santa Fe Report.

“Since the adoption of our water-treating system the mileage of fire-boxes and flues has been doubled and trebled. One of the best examples is the Los Angeles division. In the latter part of 1905, eight large Pacific type oil burning, passenger locomotives went in service on that division, and up to Decem-

ber have up to January of this year given an average service of 168,589 miles, and are still going; the flues have given an average service of over 44,000 miles, an increase in flue mileage of 78½ per cent.

Treatment Beneficial.

“We use treated water to prevent incrustation, and give credit for the prevention of incrustation and improvement in the performance of our fire-boxes and flues to the system of treating water. We use an anti-foaming treatment to prevent foaming, both with our treated water and in territories where the water is not treated. This does the work very satisfactorily, eliminating all of the troubles due to a foaming boiler, reducing the cost of fuel and lubrica-

Some Principles of Successful Storekeeping*

By J. Herriot**

The writer, who is in charge of the storekeeping department of the largest general engineering plant in this country, here deals in an interesting manner with the fundamental principles necessary to be observed for keeping the various shops well supplied, without having on hand an excessive stock.

THE stores department is one of the most important branches of any up-to-date plant, and unless it is well equipped, and the stock kept up to requirements, the other departments must necessarily suffer. In the first place, the department should be well housed with good buildings containing sufficient capacity for proper storage of raw and finished material necessary to the plant concerned, otherwise the department is handicapped by goods being scattered around, where they are overlooked and not properly accounted for. Bins should be arranged so that each class of article is together, so that the storeman may be able to locate same quickly, and not delay workmen at the wicket. There is now on the market a line of bins for stores purposes, made of steel and on the same principle as the sectional bookcases with which we are all so well acquainted. These are built up in separate units, and are so arranged that the compartments can be altered in size as requirements may demand. I had the pleasure of visiting the store-room of one of the large plants located in Toronto which was equipped with this outfit, and it certainly left nothing to be desired as regards efficiency and neatness. Bar iron, steel, pipe and tubing, and other heavy material, which in many cases are stored outside, should have proper racks, and a covering of some kind as a protection from the weather. Stores buildings should be located as centrally as circumstances will permit, so as to be easy of access from all parts of the plant. Iron and steel bar should be stored near the smith shop; other heavy material is generally unloaded as near the point of manufacture as possible, in order to facilitate handling when required to be put into production.

Shop Requisitions.

The amount of stock kept on hand is, of course, governed by the volume of business passing through the plant and orders are placed accordingly. All specifications emanating from the shop production department pass first into the stores department. These specifications detail every item which will be required in connection with the contract or sales

order involved. They are checked with the stock on hand. Any material not in stock, is ordered at once for this special job and must be reserved for same.

Material used in maintenance of plant, or what is known as "shop expense," is also handled in the same manner, but special tools required are only ordered or carried by authority of the general superintendent. In all plants there is a certain class of both raw and finished material which enters into the manufacture of standard lines and which can be safely carried into stock, but of this a maximum and minimum figure should be fixed. Any extra demand for these lines should be immediately covered by requisition. This would include iron and steel, both round and flat, rivet steel, boiler and tank plate, pipe and pipe fittings, etc. Tool steel should not, in my opinion, be carried in any quantity, as the demand for this is governed by the shop practice and can be ordered as required. Some may object to this on the ground of delay to work, but as this steel can always be procured on short notice (that is, in standard sizes) this objection cannot be sustained.

Railroad and Factory Storekeeping Compared.

From my experience both on the railroad and in the factory, I would say that the handling of railway stores is much easier than the other. In a railway stores, practically only one line of business is to be looked after, either the repairs of locomotives, repairs of cars, maintenance of way or traffic department. The material carried is always standard to these lines, and there is not much variation. The consumption from month to month generally averages the same amount, so that the stock can be always arranged to suit. Any overstock for a certain class of engine can always be transferred to some other point where this class is also stationed, and vice versa.

In an engineering plant which embraces the manufacture of varied lines, say locomotives, steam shovels, pumps, bridges, etc., you will readily understand that you cannot do this so easily, and the storekeeper's life is not always a pleasant one when he fails to keep "production" supplied.

Stores Accounting.

With regard to the "system" necessary to the proper accounting of the stores department, no two persons or no two plants have the same system, or the same opinion as to how this should be done, but I will endeavor to give you an idea of the work required in order that supplies may be properly accounted for. All requisitions for material originate in the stores department, and after being approved by the head of the plant, pass to the purchasing department (although in some cases these two departments are combined), who are responsible for the placing of the orders on the market, and who notify the Stores on whom these orders are placed. A copy of the requisition goes to the "chaser" and another copy to the "receiving clerk" who are on the Stores staff. The chaser's duty is to keep in touch with the vendor and follow the order up so that delivery of goods may be made when required and production not delayed. He has to keep all records as to promises given, and reason of delays, etc., in fact should have notes on all material outstanding.

The receiving clerk receives all material which comes into the plant, checks same with his copy of the requisition, notes any differences in weights and quantities, and makes out receiving slips, which then pass to the inventory or stock clerks, and then to the accountant, where they are compared with vendor's invoice before being passed for payment. The receiving clerk also makes out all over, short, and bad order claims against the railroad or other carrier, also checks the freight bills, etc., amount of same being entered on his report, so that goods can be priced at invoice value, plus amount of freight charges, and customs duty, if any. The customs end is handled by another department, copy of entry being furnished the receiver for his record.

No goods of any description should be unloaded without the receivers being present, and this rule is a hard and fast one, as unless it is adhered to, errors and mistakes will creep in. This rule applies not only to goods delivered by city merchants, but also to car load lots. In this connection, car loads must be carefully watched so that no delay in unloading cars occur and "demurrage" bills pile up. All cars placed on sidings by the railroads are reported to the receiver who checks up his freight advice, customs papers, etc., and if same are all clear, then gives the order for unloading, also advising where material is to be placed.

The Stores Inventory or Stock Ledger.

Some prefer the card system and others the loose leaf ledger for the stores

*Abstract of a paper read before the Central Railway and Engineering Club, Toronto.

**General Storekeeper, Canada Foundry Co., Ltd., Toronto.

inventory, but this is a matter of choice, as practically the same results are obtained from either. These cards have headings showing name of article, location, etc., columns showing receipts with numbers of receiving slip, quantities, price, issues and balance. Cards should be filed alphabetically. Goods are entered from the receiving slips, prices are taken from invoices, after same have been checked in accountant's department. Issues are made from "material order slips," which will be explained later. In addition, a card is placed in each bin with goods showing receipts and issues, so that by looking at these cards it can be seen at a glance what quantity is on hand of that particular item. This card is posted by the stores helper when delivering goods on orders from shops. It is also the practice to have an inventory clerk, whose duty it is to check up stock, he being employed on this continually, same being then compared with cards, and adjustments made if necessary.

"Material Order Slip."

This is the order placed on stores by foreman or authorized employee for material required, and no article should be issued without this order. These orders show the "shop order number" or "expense number" to which the goods should be debited, the description and quantity of material required, also drawing or pattern numbers. They pass to the inventory clerks, who enter them on their records, price and transmit them to the accountant's office, where they are handled by the "costs" department. All material left over on any job should be at once returned to stores with a credit slip, showing the order number to which the same is credited. This is taken back into stores at value issued (if in good condition) or if same has been improved, the extra labor is added to value.

Handling Scrap.

The handling of scrap material is also in most cases done by the stores department, scrap iron, steel, steel and iron turnings and borings, copper, brass, rubber, rope, etc., being classified and stored at convenient points for loading, and when a sufficient quantity accumulates it is sold. Brass turnings from the brass finishing department are also disposed of in the same manner, or else remelted in the foundry.

There are certain materials used in all plants which cannot be kept directly under the eye of the storekeeper, and he has to depend on the other departments to give the necessary orders when using them. These embrace lumber, coal, coke, etc., and workmen seem to have the idea that because it is all company's material, they are at liberty to use same at their pleasure without putting through the

proper account, which to their minds is "red tape." Men should have their minds disabused of this idea by careful instruction.

Qualifications of a Storekeeper.

Some of those present may remember a paper which was read before this club by Mr. Alfred Tory, General Storekeeper, G.T.R. System, London, Ont., in October, 1908. Among other interesting things he gave a list of the numerous qualifications required of a railway storekeeper, and as these are also applicable to the storekeeper of any large plant, I think the repetition will not be amiss:—

"A railroad storekeeper should be an integrate part, a cog in the wheel of the system by which he is employed.

"He must possess 'tenacity' and a faculty for concentration, etc.

"It is his duty to familiarize himself with all classes of material, and have a general knowledge of all classes of railroad material and be familiar with its composition and construction.

"It is his duty to supervise those under him to produce the best results.

"He must make himself thoroughly familiar with his base of supplies, etc.

"He must study the requirements of the territory depending upon his store-keeping for supplies.

"He must study the best interests of the company, using his best endeavors to prevent excessive and wasteful use of materials.

"He should keep in touch with the commercial world, to enable him to determine when and how to replace requisitions, so that the material may be furnished with as little delay as possible.

"He must inform himself by personal observation, concerning work under way or contemplated, and ascertain what material is likely to be wanted.

"It is his duty to keep in touch with his stock by personal observation, instilling into his subordinates the necessity of having ample supplies on hand at all times, to prevent delays. He must dispose of all obsolete material. Keep his stock standard to power and equipment, and avoid carrying dead stock.

He must systematize his store house in such a manner that material may be handled promptly and economically.

"It is his duty to instill into his subordinates the necessity of cleanliness—store houses, lumber yards, scrap bins—all should be models of neatness, etc.

"It is his duty to prevent the store house being made a loitering place by employees.

"He must see that store department material is unloaded promptly from cars to prevent loss of revenue by such cars being out of service.

"It is his duty to help all departments,

at any and all times, in all possible ways, and do his best to promote the general welfare of the service."

"It is his duty to maintain the strictest discipline, with store employees, especially in regard to pilfering, etc."

"He must be ready at all times to listen to suggestions, which would improve the efficiency of the store house.

"It is his duty to economically order material. He must keep accurate record of all such, ordered and received, check and inspect same and protect his employers from cheap and inferior goods, etc.

"He must understand the nature of material, and store it so that it does not deteriorate.

"He must assume full control of all scrap and surplus material that may accumulate, etc.

"He must keep a book record of all material issued, etc.

"He should meet all officers and employees with that due respect that designates the true gentleman, and treat all employees with the same courtesy as if he was conducting a commercial business.

"He should inspect all sub-store houses at outlying points under his jurisdiction, etc.

"He should be subject to order of the general storekeeper only, and report direct to him in matters pertaining to stock, etc."

From this list you will see that a railroad storekeeper has not a bed of roses by any means. If, to be a successful storekeeper, it is necessary to have all the qualifications mentioned, I am afraid there are very few of us who will be able to come up to them.

THE REDCLIFF ROLLING MILLS & BOLT CO.

NORTHWESTERN Canada is to have a rolling mill. The Redcliff Rolling Mills & Bolt Co. is building a plant at Redcliff, Alberta. The products of the works will be bars, bands, angles, channels, bolts, nuts and rivets. The rolling mill equipment will comprise busheling furnaces, a muck mill and a 10-in. Belgian finishing train of rolls. A contract for the muck mill and 10-in. finishing mill has been placed with the United Engineering & Foundry Co., Pittsburgh. Orders for the engines have also been placed. The company is now in the market for a complete equipment of bolt, nut and washer-making machinery. This machinery will be purchased by the superintendent, Robert McCleary, Medicine Hat, Alberta.

L. E. Gehman, recently assistant efficiency engineer, Canadian General Electric Co., Peterboro, Ont., has accepted a similar position with the De Laval Steam Turbine Co., Trenton, N.J.

Grinding and Scraping Compared

By F. B. Jacobs.

FOR many generations scraping has been accepted as the only satisfactory method for producing straight or plane surfaces, but owing to the develop-

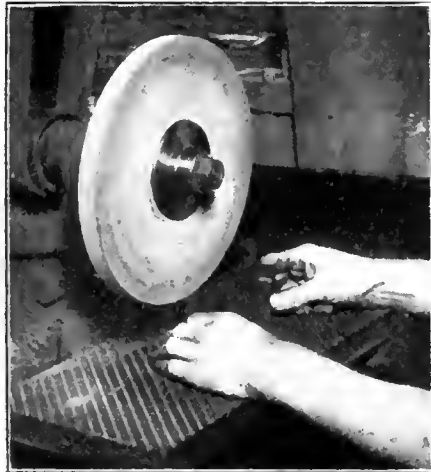

FIG. 1. GRINDING AND SCRAPING COMPARED.

ment of surface grinding machinery and grinding wheels during the last decade, the process of surface grinding has advanced to a position where it compares very favorably with other methods for producing approximate planes. To produce a plane surface by scraping calls for a skilled operator and true master planes to gauge the work by, while in

used, is the most important factor, for no matter how well a machine may be designed and constructed its output is seriously handicapped when wheels selected at random are used. It is impossible to plane, mill, or scrape any surface in a satisfactory manner without tools and cutters made of the proper materials and in the correct way. Any engineer or machinist will admit this, then why should we expect to produce accurate work by the process of surface grinding without the correct wheels? This is readily understood when we consider that heating of the work causes errors due to expansion and contraction, these forces never working evenly in all parts of the piece being ground. Admitting this, it is evident that a cool cutting wheel will produce the best results, as it reduces the factor of heating to a minimum.

Spot Grinding.

I have many times produced very accurate surfaces by the old and simple process of spot grinding, which is the oldest known form of surface grinding. This method is illustrated in Fig. 1 and consists of passing the work under the wheel by hand at various angles until the work is ground to a point where very slight sparking is visible. All that is required for this method of grinding is a reasonably plane surface to move the work on and a wheel of the proper kind, with an accurate spindle for driving it. The grooves shown in the illustration are a very good feature as they help to keep the surface free of dust.

In Fig. 2 is shown a jig base casting

on a side. Then the feet were spot-ground enough to make them sit level when tested on a surface plate. Next the top was spot-ground, then another light chip taken over the feet. Tests on the surface plate showed good bearings, and on laying the piece face downwards and testing the feet with a height gauge, no variation could be noticed. The time

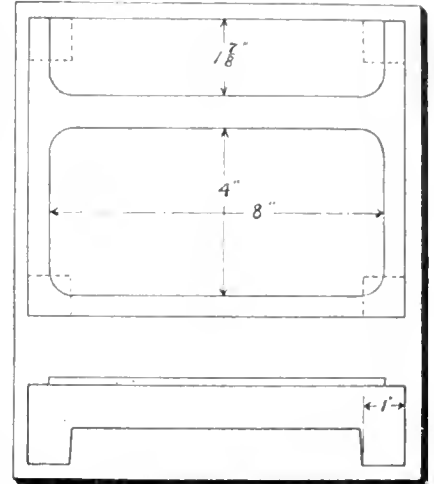

FIG. 2. GRINDING AND SCRAPING COMPARED.

consumed in grinding this piece was one hour, and when we compare this with the time that would be consumed in accurate milling or planing followed by scraping, the argument is decidedly in favor of grinding.

Surface Grinding.

In Fig. 4 is illustrated an operation where plane surfaces are required that



FIG. 3. GRINDING AND SCRAPING COMPARED.



FIG. 4. GRINDING AND SCRAPING COMPARED.

surface grinding the selection of the proper wheel as regards grit, grade, and bond, together with the kind of abrasive

that was finished in this manner. This piece was first roughed out on the milling machine, one chip only being taken

will fit in assembling without scraping them. The pieces are approximately three by two inches, having an irregular

outline. This work was done on a No. 2 Brown & Sharpe surface grinder equipped with a magnetic shoe. During some efficiency experiments with the pieces in question, it was found that when the shoe was practically filled, making a surface approximately 9x4 inches, the error owing to wheel loss was, in taking the finishing chip, only 0.0002 of an inch, which is generally considered close enough for commercial work. In grinding a surface 9x2 inches, which the illustration shows, the error was only 0.0001-inch. The slight error in both cases would seem to bear out the theory that a combination of automatic surface grinding, followed by scraping in cases where extreme accuracy is desired, would be the correct method. As a matter of fact the surface grinder is a very economical machine for both commercial and tool work, as the errors that have to be corrected by scraping are very slight.

Tool Room Work.

In grinding small surfaces in the tool room, the errors are often so slight as to eliminate scraping altogether. An illustration of this is shown in Fig. 3. Here it is desired to grind two surfaces that shall be accurate and square with each other. The work is held on an angle bracket, and after grinding, tested with a height gauge for accuracy. In cases where the work is carefully done, the error is often less than can be determined with the height gauge. It must, however be taken into consideration that skill on the part of the operator is necessary in producing accurate work on the surface grinder as well as by any other process. The illustrations given are all of small work, but it should not be inferred from this that the surface grinder is not capable of handling larger work in a satisfactory manner.

The Use of Cylinder Wheels.

The comparatively new types of surface grinders carrying cylinder wheels are giving satisfactory and economical results in cases where the principles of grinding with a cylinder wheel are understood. Here, again, the selection of a wheel is of the utmost importance, not only as regards material, grit, and grade, but also as regards its relation to the width of the work. Comparatively wide work calls for a soft wheel, while narrow work calls for a wheel a little harder than is used for wide work. Under favorable conditions where a reasonable amount of care is used, surface grinding machines carrying cylinder wheels will produce results that compare favorably with the average commercial scraping.

It is extremely doubtful if surface grinding machinery will ever reach a stage of development where absolutely (please note the word absolutely) plane

surfaces can be produced on work of medium and large dimensions. We do not look for true planes in the products of the planer or milling machine, and why should we expect them of the surface grinder? Again, how many so-called plane surfaces that we see in machine construction are really planes or anywhere near planes? At the present stage of development the surface grinder can be made to produce as accurate work as the average that is turned out by scraping, and in cases where extreme accuracy is desired, if the grinding is followed by scraping to correct the very slight errors that may exist, the results are satisfactory, as the cost of production is greatly reduced by the elimination of a large amount of hand labor.



HOT PANEL AND HOT FLOOR BORDER SYSTEM OF HEATING.

At a recent meeting of the Junior Institution of Engineers, Capt. H. Riall Sankey, R.E., discussed the subject of "Hot Panel and Hot Floor Border System of Heating." He said that the dominant feature of the new method is the use of radiant heat rather than the heating of the air. The fact is often lost sight of that the object of heating a building or room is to make people comfortable, hence it is usual to specify that the heating power and heating surface shall be sufficient to maintain the temperature of the air 5 ft. from the floor at a specified temperature of say 63 deg. F. The result has been that most of the systems hitherto adopted have been devised so as to heat the air, therefore radiant heat has been, to a large extent neglected.

It is generally conceded that for comfort, when sitting in a room without a fire, an air temperature of about 63 deg. F. is needed, and in order to obtain this temperature the surfaces of ordinary radiators require to be at the fairly high temperature of say 150 to 180 deg. F. This temperature, however, decomposes the dust in the air thus producing a disagreeable and characteristic smell. When radiant heat from a fire is available, the air temperature can be as low as 55 deg. F. or even 50 deg. F., and yet the sense of comfort and warmth is greater than in the previous case. To maintain the temperature at 50 or 55 deg. a hot water system of heating or the like will, however, be required in many cases. Such a system although ideal, is more costly.

The Hot Panel and Hot Floor System does not unduly heat the air as it supplies the radiant heat needed for comfort. A Hot Panel, Capt. Sankey explained, consists essentially of a small pipe bent backwards and forwards and imbedded in a semi-conducting composi-

tion; 1/2-inch drawn, lap-welded steam pipe is used. The heat carrying medium, say hot water, circulates in the tube, and the heat is conducted through the walls of the tube to the composition, through which it spreads to the surface of the panel, whence it is radiated into the room; in effect, heat at a comparatively high temperature issuing from a small surface is converted into the same amount of heat at a lower temperature issuing from a large surface. A hot panel may contain more than one length of tube, in order that the flow in each length may be controlled by external valves, and it can be made up in an iron frame, thus forming a detached unit similar to the ordinary radiator, or it may be built up against a wall, approximating the thickness of the plaster.

Hot borders are formed by placing drawn, lap-welded 3/4-in. pipes about an inch below the level of the floor, close to the walls, around the whole or part of a room, and imbedding these pipes in semi-conducting composition. A hot border of any width desired, say from 6 to 18 inches, can thus be formed. Similar pipes can also be imbedded along the cornices of a room. The semi-conducting composition has to be chosen with great care to obviate cracks which would otherwise be produced by the expansion and contraction of hot pipes. The various advantages of the new system were treated mathematically and a number of illustrations were given.



STEEL CO. AND FORT WILLIAM.

A Fort William report says that the president, vice-president and engineer architect of the Steel Company of Canada, the largest steel company in the Dominion, spent a few days in Fort William recently. They interviewed many prominent citizens, inspected the site which they own in the west end of the city, and left instructions to an accredited surveyor to fix the borders of their property. Although no definite announcement as to the intention of the Steel Company towards establishing at Fort William has yet been made public, it is generally understood that at no distant date they will do so.



WAGON COMPANY WOUND UP.

An order was made at Osgoode Hall, Toronto, winding up the Port Arthur Wagon Co. The order was made on the application of the German Bank, of Pittsburg, claimants for \$10,000, and the Imperial Bank of Canada.

The company, which has an office at Markham, is said to have liabilities amounting to \$350,000, and assets of \$325,000.

The United States Steel Corporation and Canada

Staff Article

It is impossible to ignore the fact that Judge Gary's story of a twenty million dollar plant at Sandwich, Ont. was made while fears were being expressed that steel manufacturers would be driven out of the United States by the Democratic party's coming tariff revision. Is it not a scheme to frighten Chairman Underwood of the Ways and Means Committee?

THERE appears to be some connection between the attitude of the Democratic Party regarding tariffs, the sudden announcement by Judge Gary that the United States Steel Corporation will build a \$20,000,000 steel plant at Sandwich, Ont., the rumors of steel manufacturers being driven out of the United States, and the story of a huge merger of Canadian and American steel companies.

The Ways and Means Committee of Congress has been sitting recently, headed by Representative Underwood, hearing evidence, and steel manufacturers claim that Mr. Underwood's methods have been arbitrary, and calculated to drive manufacturers across the border into Canada. What the Underwood Steel Bill will be like, remains to be seen, but manufacturers fear it will not be to their liking.

'We Are Going to Sandwich!'

A few weeks ago Judge Gary, president of the United States Steel Corporation made the following statement: "We have decided to establish a manufacturing plant at the site which we secured some years ago at Sandwich, Ont., just opposite Detroit. In the comparatively near future we shall commence the construction of some blast furnaces and mills. We shall probably build a wire mill, rail mill, structural mill, bar mill, and perhaps some other mills. I suppose the first cost will be in the neighborhood of \$20,000,000."

Now, there seems to be good ground for believing that this statement is the result of the Democratic Party's attitude regarding tariffs. It has been received with dubiety all over the continent. It is something Sandwich has been expecting for ten years, and now that they have the twenty million dollar plant within their grasp, there are those who say that the statement is made to offset judicial action against the Steel Trust by the Democratic Party. The Detroit Free Press is dubious. It says:—"It is difficult to forget some matters connected with the present situation. The United States Steel Corporation has owned the land now mentioned for some six or seven years and has not heretofore proceeded to cover it with mills. It has erected a new city on the lakes in that period, but while Gary was unfolding its magical development, Sandwich lay vacant as ever. Yet the attractiveness of a Canadian plant was stronger all

this time than now. The Trust was competing with Canadian industries that were stimulated by the liberal bonuses granted 15 years ago. They were protected, too, by the tariff, but the American rival stayed on its own side of the boundary, and managed to get a large share of the Canadian business despite its handicaps. The bonus system has been abolished within a year or so, and it is a little strange that just when the advantage of its benefits is withdrawn, the big steel company should decide to enter the field it has so long avoided. This phase of the matter does not tend to allay the skepticism that has come to attend the Sandwich story, it must be conceded.

Nor is it to be ignored that the announcement comes singularly apropos to the Washington tariff hearings and agitation for a higher Canadian tariff. Doubting Thomases will cynically ask whether there is any connection between these points. Can the New York dispatch have been sent out as a warning signal to the Democrats? Is it a hint to them that if they do not fix the duties at the proper point, there are other countries where enterprise is encouraged and where capital is assured of cordial reception?

Steel Merger in Canada.

As regards the merger of steel companies in Canada and the United States, it is the resurrection of a story that floated around Montreal during December, but was then received with incredulity. It has been resurrected owing to rumors coming from Washington, of dissatisfaction among steel manufacturers, and because of the United States Steel Sandwich story. This scheme, so the rumor goes, aims at a merger of steel companies in Canada and the United States, which would result in an industrial merger of even vaster proportions than the United States Steel Corporation. It would embrace in the United States some of the large independent steel companies headed by the Bethlehem Steel Corporation, and in Canada the Dominion Steel Corporation and the Steel Company of Canada. The other United States steel companies would include the Pennsylvania Steel Company, the Cambridge Steel Company, the Midland Steel Company and the Labelle Ironworks of West Virginia. The projected capitalization of this huge merger is \$1,100,000,000 divided, it is under-

stood, into \$200,000,000 bonds, \$500,000,000 and \$400,000,000 common stock.

When the whole scheme was submitted to financial interests in Montreal some 5 weeks ago, directors of the Steel Corporation and the Steel Company of Canada averred that it was all news to them, and ridiculed its possibility. Since then it is said that plans of the syndicate, which is believed to be headed by Charles M. Schwab, have been laid before President Plummer, of the Dominion Steel Corporation, and before other leaders of the steel industry in Canada.

Schwab a 'Squealer.'

The scheme sounds feasible, owing to the fact that Mr. Schwab has been one of the leading 'squealers' over the activities of Mr. Underwood and his Ways and Means Committee. His attorneys were present at the sittings of this committee 'to get a line on the attitude of the committee,' and they are credited with the statement that Mr. Schwab would abandon the steel business in the United States if the Underwood Bill was passed by Congress and signed by President Wilson.

The Montreal 'Star' thinks Mr. Schwab is bluffing, and takes all these tales of big steel corporations coming into Canada, with a grain of salt. In its issue of January 8, it says: "It would not be well for Canada to take too seriously such assertions as that made before the Ways and Means Committee of the United States Congress that the Democratic Party's handling of the tariff is going to drive industries like the steel mills of Mr. Schwab across the borderline into the Dominion. There has never been any reluctance on our part to extend hospitality, fully and freely, to such new-comers. We hope and believe that the future will bring them in increasing numbers as an appreciation of the advantages that accrue from a Canadian plant become more and more obvious to the manufacturers of commodities which Canada requires. Events, however, have fairly well justified the belief that the manufacturers themselves were not likely to erect plants in Canada until the time was ripe for them to do so.

"For a number of years the United States Steel Corporation has owned a site at Sandwich, Ontario, presumably for the purpose of building furnaces and mills. Recently it has been announced that construction work is to

he begun at once. If Mr. Schwab, piqued by the lack of consideration shown his interests by Chairman Underwood, finds his attention focussed on the Canadian field, we have no more to lose from his close scrutiny than we have to gain by intemperate statements of his intentions. Canada has not yet become embarrassed by her riches in the shape of great manufacturing establishments, but our need is not so great but that we can see things in fairly accurate proportion."

What Mr. Plummer Thinks.

Mr. J. H. Plummer, president of the Dominion Steel Corporation, taking it for a fact that what Judge Gary says is correct, expresses the opinion that there will be less dumping when the United States Steel Corporation is definitely and openly in the field as a Canadian competitor for Canadian business, as the U. S. Company do business in a big way, and are fair fighters. They will, of course, have certain advantages from experience and from the large volume of business which they do. Much of their large export trade, especially to other parts of the British empire, would probably be taken care of from the Canadian plant, and this larger tonnage, due to the U. S. Steel's extensive selling organization abroad, would help the new competitor to keep its costs low. Mr. Plummer said he had not heard whether the Sandwich story was true or not.

No Canadian Merger.

Mr. Plummer knows nothing of the rumored merger of the Canadian Steel Companies, ostensibly in self defence. He suggested, however, what is doubtless true of most of the other steel companies, as well, that if an attractive and bona fide offer for the Dominion Steel Corporation came along, he would naturally be glad to submit it to the shareholders. Nothing new as to bounties, or tariff changes is known to Mr. Plummer, except the perhaps favorable sign that no negative decision has been given.

The company does not intend, at least now, to appoint a new general manager in succession to Mr. Butler. The corporation is now following the common English system of having men at the head of the works and commercial department, without a general manager above them. Mr. Plummer, as President, of course, really assumes such general functions, where necessary. He, moreover, has no present intention of giving up his duties, as has been rumored, although for personal reasons he would be glad to be relieved.

Causes of U. S. Dumping.

The serious dumping of steel pro-

ducts from the United States last year affected the Dominion Steel Corporation, among other Canadian companies, unfavorably. This will probably make the 1912 profits somewhat less than those of 1911, although the present year is expected to be better. The United States dumping was unusually severe, and, as Mr. Plummer thinks, due to two causes, the growing strength in the States of some of the independent companies, such as the Pittsburg Steel, and Jones & Laughlin, and the influence of politics. The United States Steel Co. was, because of tariff considerations, apparently more willing than otherwise to allow home prices to sag, and thus to render the Canadian dumping laws ineffective.

Rod Duty Essential.

A very prominent Canadian steel man says that if the U. S. Steel Co. comes, a duty simply must be put on wire rods, or the effect on Canadian companies will be very serious. Otherwise the U. S. Steel would bring in its own wire rods, duty free and profit free, while other companies, would buy at that price, plus the makers' profit, and so could not compete. This steel man thinks that unless such tariff change is made, there might be only two companies left in Canada, the U. S. Steel and one other.

If the U. S. Steel Came.

Judge Gary is unable to say just when the construction of the new plant at Sandwich would begin. Part of the initial cost will be financed by an issue of bonds. The corporation's business with Canada in recent years has ranged from 350,000 to 400,000 tons annually, representing roughly from \$12,000,000 to \$15,000,000.

It has been known for months that options were held on some 2,000 acres at Sandwich by attorneys who are representing the Steel Corporation, but the rumors that a plant would be built have been heard so frequently that but little attention has been paid to them. In point of location, the Steel Corporation's property in Sandwich is regarded as very desirable, being convenient of access for vessels of the company's fleet handling iron ore from the head of the lakes, and being on the route also of upbound steamers handling coal.

CANADIAN RAILROAD CO. EXPENDITURES.

FORTY million dollars will be expended in Montreal by the Canadian Pacific, Grand Trunk and Canadian Northern Railways within the next two or three years, the main expenditure to be in tunneling through Mount Royal. The plant for the tunnel will be very com-

plete. There will be compressor plants at each end, electrically driven and consisting of one direct-connected, cross-compound unit of 2,200 cubic feet per minute capacity, and three cross-compound units of 1,100 cubic feet per minute. Pumps, drills and some small motors will also be needed and will be run by air. The drills used will be of the percussive type with the water attachment built largely of steel. Both gasoline and electric locomotives will be used.

The shops will consist of a blacksmith shop equipped with an air hammer, shears, punches, drill sharpening machinery and the usual forges; machine shops equipped with large and small lathes, a shaper, radial drills, saws and pipe machine; carpenters' shops with hand and circular saws; drill repair and testing shops, as well as garages for the maintenance of automobiles and auto trucks. The work will be started this spring.



CANADIAN AGRICULTURAL IMPLEMENTS IN AUSTRALIA.

AS a result of comparatively good seasons, it is satisfactory to observe that the figures in the Australian returns for 1911 prove that Canada maintains a predominating position in the importing agricultural implement and machinery trade of the Commonwealth. The reason is obvious, and little comment as to the cause is necessary. The leading agricultural machinery manufacturers in the Dominion have, for a period of years, established branch houses in the principal Australian importing centres, and other Canadian makers are represented by capable selling agents who carry stocks of varied magnitude. The selling organization is as nearly perfect as ingenuity can devise, and fair trading, combined with the undoubted excellence of Canadian farming machines, has secured an enviable reputation for the goods. The lead held by Canadian manufacturers in these lines has been secured by effective local management, causing not only constant vigilance as to recurrent requirements, but also in anticipating the demand for perfected implements adapted to varied farming conditions. To secure the trade, it follows that the machinery imported must be suitable for the country, and, in a number of cases the implements are—through climatic and other reasons—of such character as to be unmarketable in North America.

The result achieved is an object lesson to Canadian manufacturers of other lines of merchandise as to what trade can be obtained in distant oversea markets by persistent effort while holding an equally prominent position in the home market.

THE DEVELOPMENT OF ST. JOHN, N.B.

THE following detailed statement shows the estimated expenditures on public works and buildings now under construction in St. John, N.B. The total construction on terminal improvements will, of course, be spread over a number of years:—

Dry dock, ship repair plant and wharves at East St. John, provisional contracts \$11,500,000, estimated cost complete	\$24,000,000
C.P.R., West St. John, million bushel elevator, additional yard accommodation, reclaiming land and erecting seawall	2,000,000
Dominion Government — present dredging grant, West St. John....	900,000
Dominion Government — erection of wharves, sheds and terminal facilities, West St. John	2,600,000
Simms brush factory	350,000
Union Foundry extension	25,000
Automobile factory	50,000
Moore's saw mill	50,000
Armory	350,000
Theatre	100,000
Ames-Holden warehouse	75,000
Estimated expenditure on small buildings and residences under construction	150,000
	\$30,700,000

In addition to the thirty million dollars shown above, buildings and works at an estimated cost of almost four million dollars, as shown in the following table, have been definitely decided on, although operations have not as yet started. These amounts bring the total cost of improvements in St. John, N.B., to the very large total of \$34,660,000. In addition to this, it is estimated that several millions more will be spent by industrial concerns, etc., although no definite plans have yet been made.

New bridge, including street car tracks, between St. John and Fairville, estimated	\$ 500,000
Bank of B.N.A. Building	150,000
Merchants Bank, remodelling	50,000
Post office	500,000
Sugar refinery, \$100,000 put up as guarantee that construction will commence June, 1913	2,500,000
McClary Manufacturing Co.	75,000
Dominion Government — wharves, sheds and dredging for Marine and Fisheries Dept. (tenders called for)	185,000
	\$ 3,960,000

LET THE FACTS BE KNOWN.

IF the Ontario Hydro-Electric enterprise is as successful as is claimed for it, there is no reason why there should be so much uncertainty as to the facts. It seems surprising that there should be such variant statements of actual conditions as those given by City Auditor of Toronto, Sterling, and those of John Mackay & Co. A similar difficulty in getting at the facts is apparent in the differing statements issued by the Hydro-Electric authorities and by the investigating commission appointed by New York State.

If the burden of cost of the undertaking is not properly distributed, if charges are not made to the proper accounts, if city lighting services are made to pay too much, so that private under-

takings may receive power below cost; if these, or other wrong conditions exist, the facts should be made known to the public. In short, there seems no reason why there should be so very much public uncertainty about the whole matter or why facts of so much public concern should be so much matters of dispute, rather than of demonstration.

CHEAPER IRON FOR THE WEST.

WHEN the Panama Canal is opened for business, freight charges for both American and English pig-iron to the Pacific coast will be reduced, and there promises to be a hard fight between the furnaces around Birmingham, Alta., and those in Great Britain. At the present time English iron sells at Pacific ports for \$22, whereas No. 1 Foundry from Birmingham costs in the neighborhood of \$24.50. The result is that American iron is little seen in Washington, Oregon and California, but with the opening of the Panama Canal, a chance will be given to iron makers in the south.

It is then expected that pig-iron will be moved from Birmingham to Seattle for \$5 a ton or less, thus allowing No. 1 Foundry to sell at \$19.50, which is lower than the present English price. It must not be forgotten, however, that English prices will naturally be reduced also by the opening of the Panama Canal. The entire consumption of pig iron in the three above-mentioned States does not exceed 150,000 tons a year.

CANADIAN CAR & FOUNDRY CO.

THE Canadian Car & Foundry Co. has ordered three, single tandem, horizontal, double acting, four cycle engines, to be installed at their Fort William, Ont., plant. The engines, to be built by the Mesta Machine Co., Pittsburgh, at West Homestead, will have cylinders of 28-inch diameter by 36-inch stroke, and will operate at a speed of 150 revolutions per minute. Each engine will be arranged to drive direct connected a 600-kilowatt, 60-cycle 3-phase, 600-volt alternating current generator. The gas plant will be the largest producer gas engine plant in Canada, when completed. It will consist of four, double bituminous coal generator sets, furnished by R. D. Wood & Co., Philadelphia. The gas plant originally was intended for fuel gas purposes, but as it is necessary to intermittently change from the water gas operation to producer gas, it was decided to utilize the waste, or producer gas, for power purposes.

C.P.R. 1913 REQUIREMENTS.

THE rail requirements of the Canadian Pacific Railway Co., during 1913, will approximate 250,000 tons which, with the requisite fastenings, will represent an expenditure of over \$8,000,000, according to the announcement made by Sir Thomas Shaughnessy, president of the road. The present orders for cars and locomotives, to be delivered before the end of 1913, aggregate \$10,000,000, part of which will be spent in the United States, but the larger portion in Canada. Besides this, the important terminal works at Montreal, Toronto, Winnipeg and Vancouver and the large locomotive and car works at Ogden, near Calgary, will mean the use of a great deal of material and stimulate manufacturing in rail mill, iron and steel works.

UNIFORMITY OF SPECIFICATIONS.

IN a recent paper on "The Aims and Work of the International Electro-technical Commission" Professor Silvanus P. Thompson pointed out that it would undoubtedly be of great advantage to an engineer if he were able to draft his specifications in terms which were practically identical with those not only in use in his own country, but also in other countries in which similar apparatus is in service. What an amount of misunderstanding would be avoided if this were made possible?

At the present time, a motor correctly described as a 10-kilowatt motor in one country is not necessarily a 10-kilowatt motor in another country, because the usages and regulations as to rating, and the requirements as to the physical tests which are made to determine the normal output of the motor, differ in different countries. Surely the same tests should be required and the same temperature rises should be named as permissible in the determination of the normal rating in whatever country the machine is constructed; otherwise the intending purchaser, who is offered by rivals in trade, machines of nominally the same output, has no guarantee that the competition is a fair one.

Allan Mosher and Austin C. Taylor have severed their connection with the Dominion Steel Castings Co., Ltd., Hamilton, Ont. They are giving their attention to the Stoeck Process Steel Co., Detroit, Mich., which has recently been incorporated and in which they are the principal stockholders.

The C.P.R. have outstanding orders aggregating \$30,000,000 for cars and locomotives to be delivered before the end of the present year.

WHEN STEEL FREEZES.

At a meeting of the Cleveland Institution of Engineers, held at Middlesbrough, England, recently, an interesting paper on "When Steel Freezes" was read by Dr. J. E. Stead, LL.D. First of all, Dr. Stead gave a general explanation of what occurred when the liquid steel changed to the solid state. When water passed into ice, each crystal as it formed had the same composition as the water. With steel it was quite different, for the first crystallites that formed were purer than the mother liquid. The octohedral fir-tree type of crystals fixed themselves on the side of the mould, and then grew inwards. While growing they entangled within their branches the greater part of the less pure and most fusible portion of the metal, which was rich in carbon, sulphur and phosphorus.

When a series of crystals grew side by side and developed from the cold sides of the mould, although the bulk of the impure liquid which was last to freeze was entangled in the crystals, a portion of it was always pressed forward, and mixed with the completely liquid steel inside. That accounted for the envelopes of ingots being purer than the average of the whole ingot. When separate crystals developed towards each other, they each drove forward some of the impure liquid, and this was eventually trapped between them. Before freezing, they formed irregular liquid envelopes around the crystals and were rich in carbon, sulphur and phosphorus, and when frozen constituted what was called "intercrystalline segregation." This was often found in seri-

minimize this evil as much as possible, moulds with five, six or eight fluted sides were employed. Axial segregation was most pronounced when gas was driven off during solidification at the period when blow-holes formed in the partially solidified metal, which consisted of a solid purer part and a liquid rich in impurities. It might be taken for granted that if a mass of such a mixture were squeezed without cooling it, the impure liquid would be pressed out of it.

Cavities and Blow-holes.

Dr. Stead then dealt with the nature of the gas in cavities and blow-holes. There were several theories explaining what it was that initiated blow-holes in steel ingots. First, that the gases were more soluble in steel at high temperature than at low, and when the amount was in excess of what the plastic steel could hold in solution, they left the steel, passing out of solution. Secondly, that the gas which made the blow-hole was produced by the interaction of dissolved iron oxide and carbon, and was CO, a reaction that took place when the steel was cooling down and when it was in a plastic condition; thus $\text{FeO} + \text{C} \rightleftharpoons \text{Fe} + \text{CO}$. If this hypothesis were correct, it seemed reasonable to believe that the reverse might occur at higher temperature, $\text{CO} + \text{Fe} = \text{FeO} + \text{C}$. Thirdly, it had been suggested that hydrogen and nitrogen might initiate the gas bubbles.

In discussing those theories they must remember that the amount and nature of the gases finally imprisoned in the steel did not help one to any conclusion, for what was so left was not what

ing steel ingots, some of which were made sound by silicon addition. Mr. Talbot, on the other hand, had in the course of his experimental trials at Cargo Fleet obtained gases from the central cavities of two steel ingots, one of which was very fiery and gaseous and honeycombed, and the other made dead sound by adding 2 oz. of aluminum per ton. The analyses of gases from Mr. Talbot's ingots showed that it was CO that formed the blow-holes, that hydrogen only passed out at surfaces and had not force enough to overcome the pressure of the steel itself and make cavities, and that hydrogen was always present in gases from cavities, because it readily left the steel at surfaces once they were formed.

Dr. Stead then dealt with blisters in steel sheets and produced a photograph one-third size of a blistered sheet. One of the most interesting features was that the blisters were in sequential order, many of them being parallel to others. He had not the history of the sheet, but the peculiar parallel arrangement suggested that the blisters represented blow-holes which had not been welded up or had contained oxide of iron or other substance which prevented union. Dr. Stead concluded his paper with a study of the fracture of a honeycombed ingot.



C. N. R. ORDERS.

DIRECTORS of the Canadian Northern Railway have announced their program of purchases of rolling stock for 1913. The sum to be expended aggregates \$7,000,000, and it is noted that delivery of most of the items must be made before August 1, of this year. Apparently the intention is that the new rolling stock must be ready for use for the crop moving during the fall months.

To enable orders being filled within the eight months stipulated, the company have placed the building of the cars and locomotives with all firms manufacturing such throughout Eastern Canada. This will include Halifax, Amherst, Montreal, Preston, Cobourg, Hamilton and Toronto. The different classes of rolling stock ordered include 1,850 box cars, 700 flat cars, 300 ballast cars, 100 refrigerator cars, 150 stock cars, 76 passenger coaches, and 136 locomotives.

Hamilton and Cobourg will build 1,500 of the car orders, and Preston gets the order for the passenger coaches. Of the locomotives, 25 will be built in Toronto by the Canada Foundry Co. The company's car plant at Winnipeg will be fully occupied during the year building cabooses and rebuilding freight and passenger cars.



PHOTOGRAPH OF BLISTERED STEEL SHEET.

ous quantities along planes radiating at 45 deg. to the sides forming the corners of the large ingot. The reason for this was that the crystals grew at right angles to the sides of the moulds, and meeting them near the corners the fusible impure parts were forced in and imprisoned along a plane at 45 deg. to the direction of growth. In small ingots this was not serious, but it was in the case of very large masses. To

would make the blow-holes, but what the steel could naturally hold in solution at the point of solidification and at atmospheric pressure. What one must judge by was the composition of the gases which were retained in the cavities, or which were evolved and escaped from the steel as it approached the point of solidification. Howe, in his classical work on steel, gave analyses of gases which escaped from the cool-

NATURAL GAS IN I.C.R. WORKSHOPS.

THE workshops of the Interoceanic Railway at Moncton, N.B., are now piped with natural gas, which is being used extensively for the generation of power. Experiments conducted for some time have demonstrated that the natural gas could be used more economically and to better purpose than the producer gas from the railway plant, and this latter is to be closed down and held in emergency reserve.

The entire railway plant is now supplied with the natural gas, which is being used under six large boilers, and in all forges and gas engines, as well as for heating purposes and for the generation of electricity for both power and light. It is also being used in the general offices and in the station as fuel, with the most satisfactory results. Further, successful experiments have been made in ear-lighting, and pipe lines now supply the Pintsch gas producing plant, and the ears passing through Moncton are charged with natural gas for illumination.



CANADIAN SHIPBUILDING DEVELOPMENT.

IN view of Canada's offer of three super-dreadnoughts, the keels of which will, however, have to be laid down in the United Kingdom, it is of interest to note that very soon it will be possible to build ships in the Dominion as, according to all accounts, good progress is being made with the creation of the necessary establishments. Indeed, there are many competent authorities who do not hesitate to say that in the near future some of the finest vessels for the British Navy and mercantile marine will come from the Dominion.

Yard at Sydney, C.B.

The most important enterprise of the kind is associated with Sydney, Cape Breton, where the British-Canadian Shipbuilding Co., in which both the Fairfield Co., Govan, and Messrs. John Brown & Co., Clydebank, are interested, is now laying down plant. A site covering some 300 acres has been acquired, and, as a result of a plebiscite of the ratepayers, the municipal council has granted the company a bonus of 1,000,000 dollars in return for which, however, several important conditions have to be observed.

There are to be eleven slips, while the manufacture of guns, gun mountings and armour-plate will also be undertaken. In addition, there is to be a dry dock 1,150 feet long and 135 feet wide, with a depth on the sill at high water of 45 feet. Sydney, it may be mentioned, is the headquarters of two

of the largest coal and steel companies in the Dominion, one of the latter having facilities for the production of 250 tons of pig-iron and 1,000 tons of steel daily, so that there will be an abundance of raw materials at hand.

Yard at St. John, N.B.

At St. John, N.B., where big harbor works are being carried out by Messrs. Norton, Griffiths & Co., the plans include a graving dock 900 feet long. It is also proposed to make provision for a huge shipyard, the firms of Messrs. Cammell, Laird & Co. and of Messrs. Vickers, Ltd., being prominently mentioned in this connection. The latter are, however, at present busy with operations at Montreal, where their floating dock, 700 feet long with a lifting capacity of 25,000 tons, is now available. According to the charter, the company has the right to manufacture steel in all its branches, and to transact general business as shipbuilders and repairers.

Further, on the Pacific Coast, at Esquimalt, B.C., Messrs. Denny Bros., of Dumbarton, are interested in a graving dock and shipbuilding company, which is to receive payment at the rate of 3½ per cent. for 35 years on an estimated expenditure of \$2,500,000 for the construction of a dry dock 900 feet long, 122 feet wide, and 40 feet deep, while the building and repairing of ships will, it is expected, give employment to between 3,000 and 4,000 men. Other yards are being established at Vancouver and at Sault Ste. Marie.



HARDENING TWIST DRILLS AND TAPS.

A CONTEMPORARY gives the following methods of hardening twist drills and screw taps whereby maximum strength is said to be retained in the pieces treated:—The prepared drills or taps are held with their spiral or screwed parts submerged in molten lead (brought to red heat in iron or earthenware crucibles) till they too reach red heat. For pieces 3-16 in. to ½ in. in diameter this takes about one minute. The pieces are then withdrawn and at once plunged into water. If the lead bath is at the correct temperature, no lead will cling to the taps or drills on removing them. After chilling, the latter are cleaned and tempered.

A convenient method of tempering is to lay the drills and taps in lots of ten or twelve on a sheet of iron mounted over a charcoal fire. The plate should be rocked during the process in order that the pieces may be quite uniformly heated. On reaching a dark gold temper film, the articles are again water-quenched, and are then ready for use. The advantage of carrying out the

first heating in lead instead of by direct firing is that the degree of heating is strictly limited, and it is impossible to burn the edges of the threads and drill grooves while waiting for the core to heat. Further, by the above process only the working parts are hardened, and the heads of the taps or drills can be subsequently worked if necessary.



SHIPBUILDERS WANT SUBSIDY.

REPRESENTATIVES of all the leading shipbuilding companies throughout the Dominion, waited upon the Right Hon. R. L. Borden recently, and described the keen competition which they had to meet. It was declared that unless assistance from the Federal Government was received they would be forced to abandon the struggle.

One of the spokesmen suggested the imposition of a duty on British ships, another thought such a plan would not prevent British ships from engaging in the coastwise trade, and proposed the payment of a bonus per net ton on ships built in Canada, and a subsidy on the cost of construction to the extent of about 20 per cent.

Premier's Promise.

The Premier promised due consideration when provided with a detailed statement by the shipbuilders. He was anxious to know for what period it would be necessary to aid the industry in order to ensure its continuance, adding that he had been told by a British builder that wages in Britain and in Canada tended to approximate in 10 or 15 years. The construction in Canada of vessels required by the Government might assist the companies of the Dominion.

Major Currie, M.P., introduced the deputation, which included Captain McDougall and Sandford Lindsay, president and secretary, respectively, of the Collingwood Shipbuilding Co.; John B. Miller, president of the Polson Ironworks, Toronto; Messrs. Black and Conn, representing the Pickford and Black Co., of Halifax; H. Bullen, president of the Esquimalt and Vancouver Marine and Dry Dock Co.; Geo. D. Davie, of Lewis; S. Dymont and W. J. Fair, of the Kingston Dry Dock and Shipbuilding Co.

Torontonian's Testimony.

Mr. Miller, of the Polson Ironworks, said that at present the Canadian companies on the lakes had to confine themselves to ships which could not be built in Britain and sent through the St. Lawrence canals. On a vessel costing \$120,000, the Canadian companies were taxed about \$12,000 in duties on fittings and other "raw materials."

STANDARDISATION OF PARTS.

By "Cardilae."

THE makers of a certain machine tool for which they had held the market for a considerable time were feeling the effects of competition. Reduction of prices served as a temporary expedient to retain the trade. Finally, however, they were compelled to face the matter with a view to effecting such an improvement in the conditions of manufacture as would be sufficient to enable them to compete successfully with their rivals. The question of re-designing was considered. They held a large stock of parts which had become more or less standardised, some of them being common to several sizes. For their production special and costly tools had been devised.

To avoid the loss of capital which the modification of the parts would entail, the designer who had the matter in hand was given instructions that these parts must be incorporated in the new design. As a consequence, the new design, although improved in details in many ways, did not show as great a saving as was expected, and it became necessary to go still more deeply into the matter. Careful examination soon disclosed the fact that if no consideration had been given to the inclusion of the standard parts, more money would have been saved on each machine than was the entire value of the standard parts.

It would therefore, have, paid to scrap the whole of the stock in hand as well as the tools designed for producing the parts

Limits to Application.

The writer can cite many instances where, under the idea that standardisation is bound to pay, standard parts have been incorporated at a distinct loss. In fact, at one works the designers constantly complained among themselves of the chief's instance that standard parts must be used. Any appeal on the part of the draughtsman was without result. "The automatic machines must be kept running," or "it will cost more to change methods of production and scrap tools than the suggestion is worth," was the ever-ready response. Oftentimes, in order to use a standard part it was necessary to adapt it at a cost far exceeding its value—a dollar spent to save a dime. This, however, was not the worst aspect of the matter. Machines were rendered less compact than they ought to be; sometimes much more complicated. It did not pay to effect an improvement, and many such causes eventuated in the production of a machine which was not as suitable as it might be to its purpose.

Standardized Methods.

The very same result has been occasioned by standardized methods and designs in a certain American industry, and it is now suggested that a similar system of holding back progress towards perfection in design is to occur in England. Manufacturers are considering the advisability of standardizing their product at least in certain lines in exactly the same way. Whilst it cannot be doubted that a cheaper, perhaps better article will be thereby produced, there is at the same time a distinct danger that progress towards perfection in design will by this procedure have received its death blow. The effect on the present will be good, but the increased profits of to-day will be squandered in the losses of to-morrow. Just like the firms who in the good old days of various trade booms wrote down the value of plant to zero, and now if they make a 10 per cent. dividend place it to the credit of careful management, whereas in actuality that profit was made in the time of the booms, and if those booms had not been, neither would to-day's profits have been.

Careful Study of the Subject Commended

Standardization is all very well in its place, but it can be overdone in machine tool work. To standardize small parts common to many units is a valuable aid to dividend earning, but the standardization of the units themselves may result in the very reverse. It is the practice of some firms to build all the small units of machine tools in large batches. Some of these units are common to two, three or more machines, different in size. Naturally, the unit must be capable of fulfilling the requirements of the largest machine; hence, is unnecessarily large, if not cumbersome, for the smaller sizes. How far it is justifiable from the point of view of economy in production to adopt this form of standardization ought to receive the careful study of the manufacturer. It is to be feared that the consequences are not always fully considered. The saving to be effected by mass production is undeniable, but it has its limits.

The writer would unhesitatingly assert that it never pays to use the same unit for a smaller size if the cost of manufacture is not cheapened. If it would cost the same to make the smaller sizes even after adding to them the amount lost on the larger sizes by the reduced volume of production, make the smaller size. It is always necessary in applying some part larger than need be for its purpose, to make excuses for its presence, not merely to the client, but to one's own sense of the fitness of things. In many cases cumbersome would mean loss of efficiency in use. To move about large

masses of metal in obtaining certain functions would tend to tire the operator and reduce output. In certain cases loss of power is entailed.

The question of wholesale standardization needs a vast amount of consideration in which the manufacturer would do well to give most careful attention to the points raised in the above random remarks.



INCREASED MILEAGE BETWEEN TIRE TURNINGS.

A TYPE of lubricator which was developed to meet the requirements of electric locomotive service through the St. Clair Tunnel was recently illustrated and described in the Electric Railway Journal. The oil for this lubricator is contained in an air-tight receptacle of one-quart capacity, whence it is led to the wheel flanges by pipes and sprayed upon the flanges by jets of air. The air is supplied from the main reservoir by a ¼-in. pipe, which is connected to the oil receptacle above the surface of the oil. A branch of this pipe is connected to the oil delivery pipe which leads to the flanges. When used with electrical equipment the air is controlled by an electric push button, so that the lubricant is applied only when needed, as on curves.

This apparatus has been in successful operation since July 10th, 1910. The six electric locomotives to which it has been applied haul 1,000-ton trains up and down 2 per cent. gradients on which flange wear had been quite heavy, owing to the many curves and the rather low centre of gravity of the locomotives. This lubricator has so improved conditions that 50,000 miles and more are made between wheel tire turnings. This means that the wheels can be removed for turning at the same time that the armature is removed for commutator dressing. The former mileage made between tire turnings was from 12,000 to 25,000 miles. Filtered reclaimed armature bearing oil is used as the lubricant.



THE TRAINING OF SALESMEN.

IN order to train their salesmen along practical lines the Carnegie Steel Company established a school to show the men how iron and steel and their products are made, to familiarize them with the materials they sell, to illustrate the care exercised in the various processes, and to demonstrate wherein the goods excel those of competitors. A paper read recently before the American Iron and Steel Institute by Mr. J. M. Camp contains an account of the course of instruction adopted.

The first few days are devoted to the

general principles of the manufacture of iron and steel, followed by a treatise on the foundation of the industry and the Lake Superior ores, with an account of their commercial grades and the different ranges, and of open cut, milling, and underground mining. The operations of loading the boats and transferring the ore to the cars and to the furnace bins are dealt with, and also the actual process of coke making. The requirements constituting a good quality of limestone are explained, and, with the necessary raw material on hand, the next few days are spent in studying the construction and operation of the blast furnace, together with the Bessemer and open-hearth processes and the manufacture of steel, its composition, testing, and analysis. A study of rolling mills and their products concludes the technical instruction, and the rest of the tuition relates to the path followed by orders from the office and other matters connected with clerical routine. It is stated that, so far, 25 students have passed through the course, with results that are regarded as gratifying to both the salesmen and the officials of the company.



CUTTING AND GENERATION OF GEAR TEETH.

A PAPER on "The Principles and their Application in the Cutting and Generation of Gear Teeth by Modern Gear Cutting Machinery" was read before the Manchester Association of Engineers, recently, by Mr. Vincent Gartside. The paper was intended to be of practical value to the "man in the shop" who has to deal with the use or production of cut gearing. Descriptions of the most common forms of teeth, namely, the cycloidal and the involute, were first given, after which the author went on to describe the different processes employed in cutting the teeth, dividing them into two main classes—non-generating and generating. Under the head of non-generating, the author described the three systems of milling, planing and forming. The paper included descriptions of the leading types of gear cutting machines now in use, including those made by Darling and Sellars, the Fellows, Sunderland, Holroyd's worm gear milling and grinding machines. The section dealing with helical and spiral gears contained brief descriptions of the different types in use, including (1)—the simple spiral or single helical gear cut with disc cutters or hobs or planed; (2)—the Lewellen double helical gear cut with disc cutters; (3)—the Wuest gear cut with hobs; and (4)—the Chevron gear with multiple helical teeth cut by end mills.

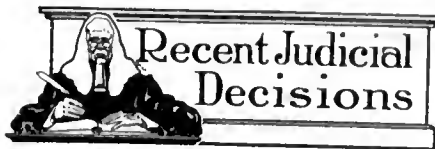

Montreal, Que.—Judge Lafontaine recently awarded a workman a pension of \$100 per year for loss of a foot that was amputated through being frost bitten while following his employment.

Toronto, Ont.—On the ground that Michael McCormick, a C.P.R. contractor, did not guard against falling rock, Chief Justice Falconbridge has dismissed the appeal from judgment against his company in the case of George Dallontania, who was awarded \$6,000 damages for injuries sustained in the C.P.R. tunnel near Sudbury.

Calgary, Alta.—At the enquiry into the death of George Beuk, the jury found that he met his death from shock and burns received from an explosion of natural gas in the basement of the Queen's hotel, Dec. 8. The explosion was due to a defect in the gas service in and around the said Queen's hotel, due to negligence of both the Canadian Western Natural Gas company and the City of Calgary. They censure the city of Calgary for not having a proper official on the scene immediately after the explosion.

Los Angeles.—The complaint in the long-expected suit of the Federal Government against the Southern Pacific railway, involving title to \$250,000,000 worth of supposed mineral-bearing lands in Fresno county, has been filed. The suit is filed under the act of Congress passed July 27, 1866, requiring the department of the interior to exempt mineral-bearing lands in issuing patents to railroads. The land is, for the most part, in the Coaling oil field.

Montreal, Que.—Judgment has been handed down by the Dominion Board of Railway Commissioners disallowing the increase of cartage rates on freight proposed by the railway companies to be effective in Eastern Canada, but providing that the companies may impose rates not exceeding two and a half cents per hundred pounds and that the minimum toll charged for any complete single shipment shall not exceed fifteen cents. While granting a half cent increase per hundred pounds to the railroad companies, this judgment materially decreases the rates they proposed to charge. On October 7 of last year, the companies amended their tariffs, imposing a charge of three cents per hundred pounds, and a minimum rate of 20 cents in Montreal. The change was to have become effective on November 11.

Toronto, Ont.—An agent of the London Machine Tool Co. named Strong, brought action to recover commission upon the sale of the assets of this company to the Canada Machinery Corporation. Mr. Justice Middleton's decision was as follows: "I do not think that either plaintiff's or defendants' contention is sound, and that when defendants accepted plaintiff's services as intermediary in promoting the sale, he became entitled to receive a commission. The sale he arranged falling through, the dependent agreement also came to an end, but I think plaintiff is entitled to something because he set on foot the negotiations which ultimately resulted in the transaction actually carried out. I have difficulty in determining the amount that should be recovered, but, bearing everything in mind, I think the sum of \$5,000 would be fair."

Montreal, Que.—Sidney Levine, a commercial traveler, has been awarded \$100 damages in a libel suit entered against the C.N.R. Company. Levine was accused of having attempted to defraud the company by presenting an irregular ticket to the conductor of one of the company's trains west of Winnipeg. The charge was embodied in a communication and sent to the secretary of the Dominion Travelers' Association by one of the company's officials, alleging that the plaintiff's certificate of membership had been cancelled on the ground that he was not worthy to enjoy the privileges attached to membership in the organization.

Toronto, Ont.—A piece of iron crashed into a house 700 yards away from the Canada Foundry plant recently, where dynamite was being used to break a casting, doing \$200 worth of damage. Under section 247 of the Criminal Code, the Canada Foundry were charged in the police court, and after hearing the evidence, and an explanation from Chas. Farr, who conducted the blasting operations, the magistrate remanded the case till called on. Assistant Crown Attorney Hughes remarked that this would meet the case, as it would serve to make it known to all, the liability which any one using explosives was under.

The section of the code under which the charge was laid reads as follows:

"Every one who has in his charge or under his control anything whatever, whether animate or inanimate, which, in the absence of precaution or care, may endanger human life, is under a legal duty to take reasonable precautions against and use reasonable care to avoid such danger, and is criminally responsible for the consequences of omitting, without lawful excuse, to perform such duty."

STEEL BELTS FOR POWER TRANSMISSION.

Steel belts have been used during the past year in some of the large manufacturing plants at Huddersfield, England, and have proved satisfactory. It is found that a 7/8-in. steel belt, weighing 119 lbs., does the work formerly done by a leather belt 22 ins. wide, weighing 814 lbs., driving 300 h.p. In another mill a 3 1/2-in. steel belt, weighing 12 lbs., does the work of a leather belt 12 ins. wide, weighing 64 lbs., driving 40 h.p. The steel belt saves space, does not slip or stretch, and gives greater efficiency of power delivery. Tests have shown a saving of 61 h.p. on a drive of 640 h.p.



THE MODERN GAS PRODUCER.

THE development of the gas producer formed the subject of a paper read before the Liverpool Engineering Society, recently, by Mr. F. Fielden. He said that the gas producer method of combustion is most commercially profitable with light moist fuels. He gave examples where spent tan, containing as much as 50 per cent. of moisture, is used in producers, the fuel being first gasified and the gas burnt in boiler furnaces. Such a plant has been working for some years at a tannery in Run-corn, while a more recent installation said to be the largest in the world for dealing with this waste product, is one of 700 horse-power now being erected at Ditton, in which 300 horse-power is

to be used for power purposes and 400 horse-power for combustion under existing steam boilers. With a moisture content of 50 per cent., the consumption per brake horse-power hour amounts to approximately 3 1/2 lb., and the gas produced with this weight of spent tan is from 70 to 80 cubic feet at approximately 125 to 135 B.Th.U. per cubic foot on the lower scale.

On the subject of the application of gas power to marine purposes, the author said that the successful gas producer should be (1)—of the bituminous type, (2)—with open-hearth firegrate, (3)—with cascade type of washers and coolers in which no loose pieces of any description such as coke, earthenware, &c., are employed, (4)—with rotary tar extractors, and (5)—having the gas pipe connections to the engines so arranged by means of suitable cocks that when the gas is suddenly cut off from the engines, the same movement of the valve lever by-passes the gas to a boiler adapted to both gas or solid fuel firing, the boiler being used to supply steam for working the winches, etc.



A NEW ALLOY OF IRON THAT IS RUSTLESS.

CHEMICALLY pure iron—that is (Fe) without carbon or other alloy—is quite free from oxidization; but it lacks the strength of steel and will not resist abrasion well. For certain purposes, however, like corrugated metal culverts,

fence wire, etc., pure iron has been used with great economic advantage. If reports are correct, a rustless alloy of iron has been recently made in France. Professor Borchers of Aix-la-Chapelle, a well known metallurgist, is credited with having produced an iron alloy which resists even boiling nitric acid. The alloy consists of ferro-chrome (having very little carbon) and molybdenum. Titanium and vanadium give results not quite as favorable as molybdenum. The important question of cost is, as yet, unanswered, as is the question of strength. Nevertheless, we have in this announcement a finger post that may point the way to securing a commercial, rustless iron alloy for use in engineering structures and machines.



ELECTRIFICATION OF RAILWAYS.

AN American engineer has recently pointed out in connection with the electrification of railways that if the choice of system rested only on the locomotives, undoubtedly the standard 600-volt direct-current system would be chosen in the large majority of cases as being the simplest and best adapted for the work, but for the electrification of a main line this is an economic impossibility, because the low voltage requires too great an expenditure for sub-stations, which must not only be large but numerous. The efficiency is too low except where the traffic gives a good load factor. It is only possible with a third rail system on account of the enormous currents required. It is, therefore, generally accepted as a fact that the current must be taken from an overhead trolley. It then becomes a question as to how much current can be collected from an overhead wire, and this is really the most important problem of any. It is probably safe to say that a current of 200 to 300 amperes may be continuously collected at high speeds, either by wheel or some form of roller or sliding shoe. The wheel can scarcely be considered for high-speed locomotive work for obvious reasons, but both roller and sliding pantograph trolleys have been used.



Mr. H. J. Fuller, president of the Canadian Fairbanks-Morse Co., and Mr. F. P. Jones, general manager of the Canada Cement Co. have been elected directors of the Canadian Bank of Commerce.

The Albion Motor Car Co., Ltd., of Glasgow, Scotland, a large manufacturer of motor trucks, has arranged to establish a factory garage for assembling cars in Montreal and proposes in the near future to manufacture in Canada.

STATISTICS OF CANADIAN INDUSTRIAL CENTRES.

TOWN OR CITY—	POPULATION.	VALUE OF PRODUCTS.		
		1890.	1900.	1910.
Montreal	470,450	\$67,654,060	\$71,099,750	\$166,296,972
Toronto	376,538	44,963,922	58,415,498	154,306,948
Winnipeg	136,035	5,611,240	8,616,248	32,694,349
Vancouver	100,401	1,895,216	4,990,352	15,070,305
Ottawa	87,062	8,822,051	7,638,688	20,924,331
Hamilton	81,969	14,014,521	17,122,546	55,125,946
Quebec	78,810	11,800,360	12,779,546	17,149,385
Halifax	46,619	7,198,143	6,927,552	12,140,469
London	46,300	8,225,557	8,122,385	16,273,999
Calgary	43,701	258,900	599,444	7,751,011
St. John	42,511	8,131,790	6,712,769	10,081,667
Victoria	31,600	4,547,186	2,617,573	4,244,034
Regina	30,213	1,313,274
Edmonton	24,900	243,778	4,493,304
Brantford	23,132	4,280,999	5,564,695	15,866,229
Kingston	18,874	3,113,573	2,045,473	3,860,142
Maisonneuve	18,681	3,653,584	6,068,780	20,813,774
Peterborough	18,360	2,594,996	3,789,164	10,033,119
Hull	18,222	1,287,292	2,182,050	7,259,301
Windsor	17,829	953,030	1,260,947	3,771,706
Sydney	17,723	335,745	631,396	9,395,017
Glace Bay	16,562	132,500
Port William	16,499	111,507	534,097
Sherbrooke	16,406	2,043,094	2,252,293	3,494,510
Berlin	15,196	1,825,722	3,307,513	9,266,188
Quehph	15,175	2,973,927	3,689,183	7,392,336
Westmount	14,579	102,500	1,541,802
St. Thomas	14,031	2,392,792	2,248,846	3,573,820
Brandon	13,839	733,800	541,327	2,330,430
Moose Jaw	13,823	135,010	738,818
Three Rivers	13,691	977,496	1,187,373	2,472,040
New Westminster	13,199	1,408,752	1,029,722	2,853,744
Stratford	12,946	1,491,462	1,935,176	5,133,840
Owen Sound	12,558	1,582,518	1,173,477	2,852,267
St. Catharines	12,184	2,444,680	2,070,543	6,024,217
Saskatoon	12,004	847,354
Verdun	11,629	229,299
Moncton	11,345	1,973,536	1,291,036	3,233,565
Port Arthur	11,220	394,015	165,000	973,668
Charlottetown	11,198	1,417,346	900,430	738,228
Sault Ste. Marie	10,984	107,510	738,472	1,002,834
Chatham	10,770	2,116,161	2,714,977	5,023,560
Lachine	10,639	1,358,325	2,909,847	6,295,710
Galt	10,289	2,621,310	2,225,313	5,252,600

MACHINE SHOP METHODS ^A_N^D DEVICES

Unique Ways of Doing Things in the Machine Shop. Readers' Opinions Concerning Shop Practice. Data for Machinists. Contributions paid for.

A GRADUATING FIXTURE.

By A. L. Monrad.

THE illustration represents a very simple, but absolutely accurate graduating fixture to cut twenty-five divisions on a thimble (A), indicated in the drawing. Lines on this thimble were at first rolled in a machine; but that method proved very unsatisfactory for the simple reason that after the thimble had been turned and finished on the automatic screw machine, the diameter on the angle was found to vary a thousandth or two, and when the divisions were rolled, the last line would be considerably thick-

over. In each corner is drilled and counter-bored a hole for a wood screw, so that the plate can be fastened on a bench during operation. The block (C) is made of cast iron, and finished all over. On the top of it is milled a straight $\frac{3}{4}$ -inch slot to a sliding fit for the cutter (B). In the bottom of this slot, at one end, is milled an elongated pocket to allow the stop screw in the cutter to move back and forth freely. In the centre of the block is bored, reamed and counterbored a $\frac{3}{8}$ -inch hole on an angle of 15 degrees. This is a turning fit for the spindle (E). Through the other end is drilled a $\frac{1}{8}$ -

inch hole in place by a steel plate (Z) which has three fillister screws on each side. The cutter slide is operated by a steel handle (L), driven in on top. On the bottom end of this handle is fitted a hardened stop screw (M). The other end of the slide is machined to a V-point. This end is hardened and drawn to a light straw color. The tool steel spindle (E) is made a turning fit in the block. A $\frac{1}{8}$ -inch hole is drilled through its centre for the knockout rod (N) which knocks out the arbor (O), when changing for a different length of thimble. On the end of this spindle fits a stop plate (P) and the index plate (G),

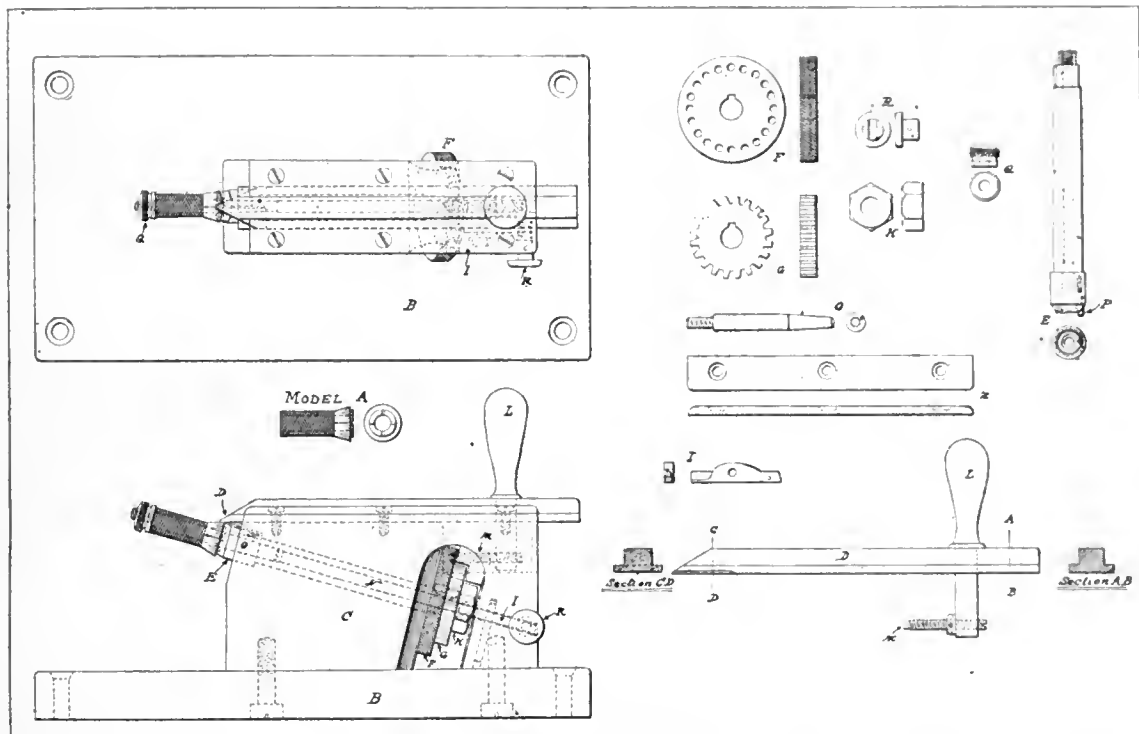

A GRADUATING FIXTURE.

er than the rest, sometimes twice as thick. It was therefore decided to discard the graduating machine entirely and a new method was adopted which has proved entirely satisfactory. The cuts of the lines are made one ten thousandth deep, so that when the diameter on the thimble varies by a few thousandths it makes no material difference, as the depth of the lines can hardly be noticed.

In detail the fixture is made as follows: It is held with two screws on a cast iron plate (B), which is planed all

inch hole to be used for the arbor knockout rod. At right angles with the spindle hole is milled a $\frac{3}{4}$ -inch, three-step plate to accommodate the stop plate (F), index plate (G) and the spindle nut (H). On the centre line and parallel with the spindle a $\frac{1}{8}$ -inch slot is milled on the side of the block to fit the index finger (I). A 5-16-inch hole is counterbored on the end of this slot to receive the spiral push spring and button (R).

The cutter slide (D) is made of tool steel with a sliding fit in the block, and is T-shaped on the bottom. It is held

these being held securely in position with a woodruff key and a nut (H).

The other end of the spindle is recessed to fit the bottom of the thimble, the outside diameter being slightly smaller than the work. In its centre is a taper reamed to fit the different lengths of arbors. On the one side of the arbor hole is located a spring plunger (P) held in position with a stop. The thimble (A) has two round grooves milled across its centre line at right angles to each other. These sometimes vary in depth. Therefore, when the thimble is placed on the arbor it will always locate itself central

with the plunger, as the long lines on the thimble must be central with the grooves. A knurled nut (Q) on the end of the arbor tightens the thimble securely in place.

The stop plate (F) has 25 stop holes milled on an angle of 15 degrees. Every fifth hole is 1-16 inch longer than the others, so that when the stop screw (M) comes up into the plate hole it cuts the division lines automatically short and long. This plate is made of tool steel, hardened and drawn to a light straw color. On the index plate (G) are milled 25 tapered grooves equally spaced. In these grooves the index finger (I) fits and is held to the block with a 1/8-inch pin in a rocking position. A spiral spring on the other end of the index finger holds the pointer down into the grooves. By pushing down on the button (R) with the right thumb, while the left hand turns the knurled stop plate round, the index finger locates itself into the index plate. Push the handle up to a stop and back again. Repeat the same motion until the 25 divisions are all cut automatically.



A CRANK SHAFT TURNING JIG.

By G. Barrett.

THE cut herewith illustrates a useful jig for turning crank shafts. The stool (A) is secured to the lathe face plate by four bolts and at its other end runs in a cast-iron steady rest (B), which is bolted to the bed plate. It will be noticed that the large end of the stool (A) is recessed to fit the face plate to ensure its running true when replaced. The smaller end of the stool is equipped with an adjustable bracket (C), which receives the web of the crank and also

of the crank, the reading being given by a pointer and an ordinary 4-inch steel rule (D) pinned to the face of the stool. The right hand end of the shaft is carried in the usual way on the loose spindle by means of a crank block. The

zontal boring mill, the table being set over an amount equal to the distance between the centre lines of the cylinder and the base. When the turret is turned 180 degrees the opposite cylinder opening is brought into alignment with

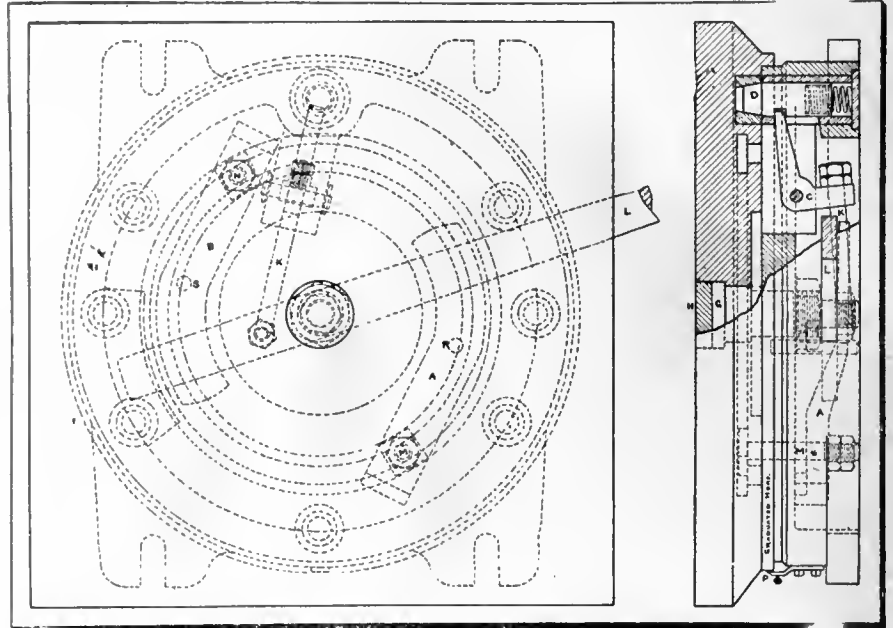

TURRET ATTACHMENT FOR MILLING MACHINE.

use of this jig not only increases the accuracy of the work, but also decreases the time required by about 50 per cent.



A MILLING MACHINE TURRET.

By D. O. Barrett.

IN ANY gas engine shop there is always considerable milling work of various kinds on which a turntable or turret can be used. A great deal of

the spindle. This same method may also be used with other holes, finished pads, etc. The turret shown is not so much used for directly clamping pieces to be machined thereon, but rather for holding jigs, some of which may have even been used on other machines. It will soon pay for itself as there is an endless variety of work for which it is suited.

The body, or base, of the turret is equipped with a set of four lugs to suit the machine on which it is to be used. Steel guides are inserted in the bottom of the bed for locating in the table slots. Should it be desired to use it on a machine other than the one for which it was originally designed and with a different arrangement of slots, two diametrically opposite clamping bolts could be used and an extra slot milled in the bed to accommodate the steel guides. The upper face of the bed is finished flat with a raised portion in the centre, about which the table turns. The shoulder bolt (G) holds table and bed together. The large nut on the under side of the bed tightens the shoulder bolt, but this is not used in any way for clamping down the table, merely holding it in its proper position. To exclude dust a plug (H) is placed in the table over the shoulder bolt. Around the under side of the table and of as large a diameter as practicable is cut a circumferential T-slot, in which are the clamping bolts (M) and (N).

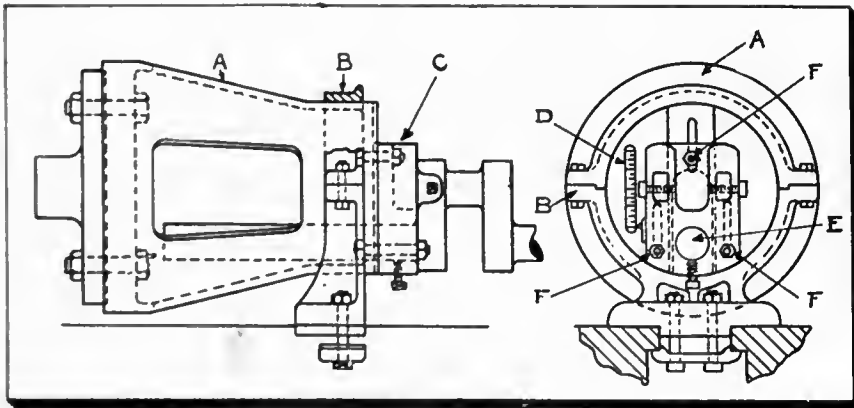

A CRANK SHAFT TURNING JIG.

the end of the shaft—the latter being inserted through the hole (E). To fit this hole there are a number of steel bushings bored to suit various sizes of shafts.

By means of the three bolts (F) the bracket (C) is adjusted to suit the throw

this is straddle milling, such as connecting rods, rocker arms; also facing and boring beds, etc.

This turret is especially handy for opposed engines, in boring the beds for the cylinders and other parts. It may be used on a milling machine or hori-

The flat pieces (A) and (B), through which the bolts (M) and (N) pass, are turned up square at one end to bear against the under side of the bed, while the other end is made on a taper. To secure effective clamping, the holes for the bolts are drilled near the turned-up ends. The pins (R) and (S) hold (A) and (B) in their proper positions at all times; these are simply straight pins driven into the bed. The clamping bolts are supplied with locknuts so that necessary adjustments can be made at any time.

Below the larger threaded portion of the centre bolt (G) is a bearing, turned smaller than the thread diameter, about which the lever (L) operates. Below this the pin is again threaded, and nuts hold up the lever. This lever reaches across the base so as to operate both the clamping pieces (M) and (N), bearing against the tapered portions of each. As the lever is pulled to the left it forces these down and effectively clamps the table.

The upward thrust on the lever is taken up by the edge of the bed on the one side and by a special pad on the other. Operating from the lever (L) is a rod (K), which slides through the forged bell crank (C), adjustment of length being made by locknuts. One end of the bell crank engages the slot in the tapered indexing pin (D), which is pushed up into the indexing bushings by the heavy spring at the bottom, this being held in by the plug shown.

It is thus seen that as the handle is pushed to the right the tapered clamping pieces are released and the index-

ing pin drawn, all in one operation, by the use of one hand, leaving the other hand free to turn the table. Pulling the lever to the left allows the indexing pin to be pushed into place and any

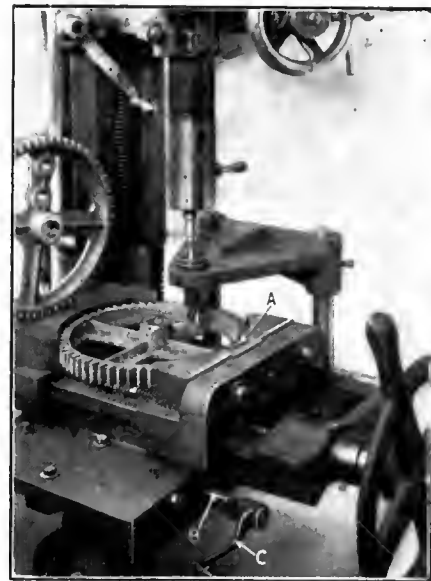

FIG. 2. GEAR AND PULLEY DRILLING AND REAMING FIXTURE.

ing pin drawn, all in one operation, by the use of one hand, leaving the other hand free to turn the table. Pulling the lever to the left allows the indexing pin to be pushed into place and any

ing pin drawn, all in one operation, by the use of one hand, leaving the other hand free to turn the table. Pulling the lever to the left allows the indexing pin to be pushed into place and any

ing pin drawn, all in one operation, by the use of one hand, leaving the other hand free to turn the table. Pulling the lever to the left allows the indexing pin to be pushed into place and any

GEAR AND PULLEY DRILLING AND REAMING FIXTURE.

By Avery E. Granville.

WE use a great many cast-iron gears in which three holes must be drilled and reamed, and have made the special fixture shown in the accompanying cuts, to facilitate the work.

The main part of the fixture, as shown in Fig. 1, consists of a vise with formed jaws made of east iron, into which a steel block (A), is fitted to locate the gear to be drilled, a tooth at right-angles to the arm to be drilled fitting the slot in this block. This vise is fitted to a base or cross-slide, which may be moved to give the different drilling positions under the spindle.

The various drilling positions are located by means of the pin (B), which fits index holes in the slide. A handle (C) turns a shaft which has a pinion on it meshing with a rack under the base, thus making it easy to move the fixture to the desired place. A bracket set on strong posts that are fastened to the table of the drilling machine, is used to hold the various bushings. This bracket is shown in Fig. 1 with the drill bushing for the hub in place. For reaming this bushing is removed entirely. The fixture set for the drilling of one of the crank holes is shown in Fig. 2. A bushing is also shown slipped into the larger one, to guide the drill used. By removal of the steel piece (A), the vise is used for the drilling and reaming of a special sized pulley, as shown in Fig. 3. After these pulleys have been reamed, they are pressed onto a mandrel and the rim is turned.

Where a firm has gears or pulleys that are run through in large lots, a fixture of this type will prove extremely valuable. With slight modifications, it can be made to take any ordinary size.



DOMINION STEEL CORPORATION.

MR. J. H. PLUMMER, President of the Dominion Steel Corporation, spent a few hours in Montreal recently. He said that the coal department of the corporation was doing an excellent business, and that the steel plant was very busy at present, there being five blast furnaces in full operation, and the coke ovens working well. He intimated

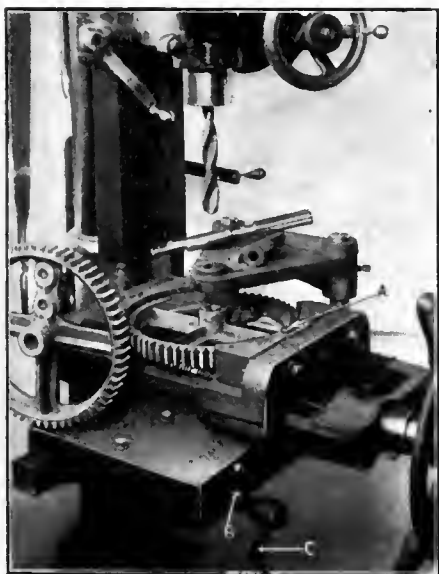

FIG. 1. GEAR AND PULLEY DRILLING AND REAMING FIXTURE.

ing pin drawn, all in one operation, by the use of one hand, leaving the other hand free to turn the table. Pulling the lever to the left allows the indexing pin to be pushed into place and any

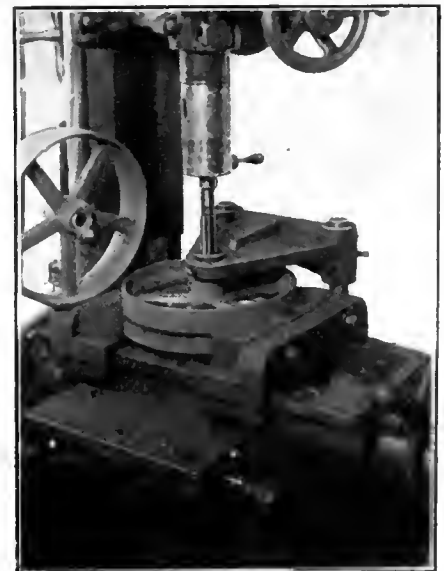

FIG. 3. GEAR AND PULLEY DRILLING AND REAMING FIXTURE.

that the output of the steel products will be a record one this year, but profits are likely to be curtailed by lack of a bounty or tariff on wire rods.

DEVELOPMENTS IN MACHINERY

A Record of New and Improved Machinery Tending Towards Higher Quality and Economical Production in the Machine Shop, Blacksmith Shop or Planing Mill.

HIGH SPEED SENSITIVE RADIAL DRILLS.

THE illustrations show a line of high speed radials recently developed by the American Tool Works Co., Cincinnati, Ohio. These have been specially designed and built for drilling and tapping small diameter holes at high speeds, the aim being to combine the high speed efficiency of the plain sensitive drill with the productive capacity of the radial. In this manner the drilling and tapping of holes up to and including $\frac{3}{4}$ -inch diameter, in such work as automobile parts, cash register details, etc., can be accomplished with great economy. An essential feature in such drills is the ability to cut down the time occupied, after one hole is drilled, in setting the machine for the next. This point has been kept in mind in the design, and all levers and operating members are placed in conven-

the rack pinion shaft. The head can be moved rapidly along the arm by means of a rack and pinion operated by a hand wheel. The latter is located on the front of the head on the left of the operator, who can thus swing the arm with his right hand and at the same time adjust the head along the arm with his left.

The head consists of a main saddle which has a bearing on the arm and carries an auxiliary sliding head upon a vertical dovetail. This sliding head is so arranged that it can be moved to or from the table, enabling a wide range of work to be accommodated.

The "American" sensitive radials are built with stationary or elevating tables, or with pedestal base (no table) for large castings. The elevating table is of semi-box construction, with a wide bearing on the face of the column. Its vertical movement is derived from the ele-

vating screw, which is operated through mitre gears by a crank in front.

There are no gears anywhere in the driving mechanism of these drills, the drive being by a 2-inch double belt running at a high rate of speed. The spindle belt tension is regulated by turning the star knob located on the bracket at the outer end of the arm. The spindle is provided with a dust-proof self-lubricating ball thrust bearing and has six changes of speed, from 300 to 900 R.P.M., in geometrical progression. It is fitted at the top with an adjustable stop collar which may be used as a depth gauge.



12-INCH CAM CUTTING MACHINE.

THIS machine has been designed by the Garvin Machine Co., New York, to meet a popular demand for a minimum sized cam cutting machine. It is well

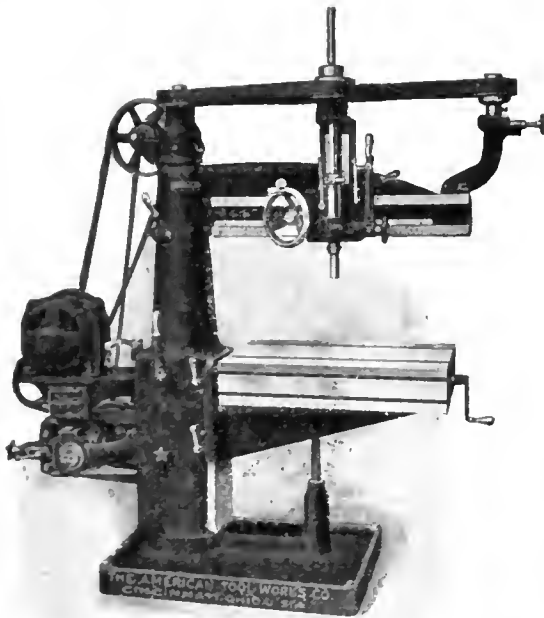

MOTOR-DRIVEN "AMERICAN" SENSITIVE RADIAL DRILL, WITH ELEVATING TABLE AND TAPPING ATTACHMENT.

ient positions for the operator. The feed lever is located on the head, directly in front of the operator, on his right side. An advantage of the ratchet feed lever used on these drills is the fact that when the lever is placed in its vertical position it is automatically disengaged from the rack pinion shaft and the spindle can then be adjusted quickly up or down by means of a small star knob on the end of

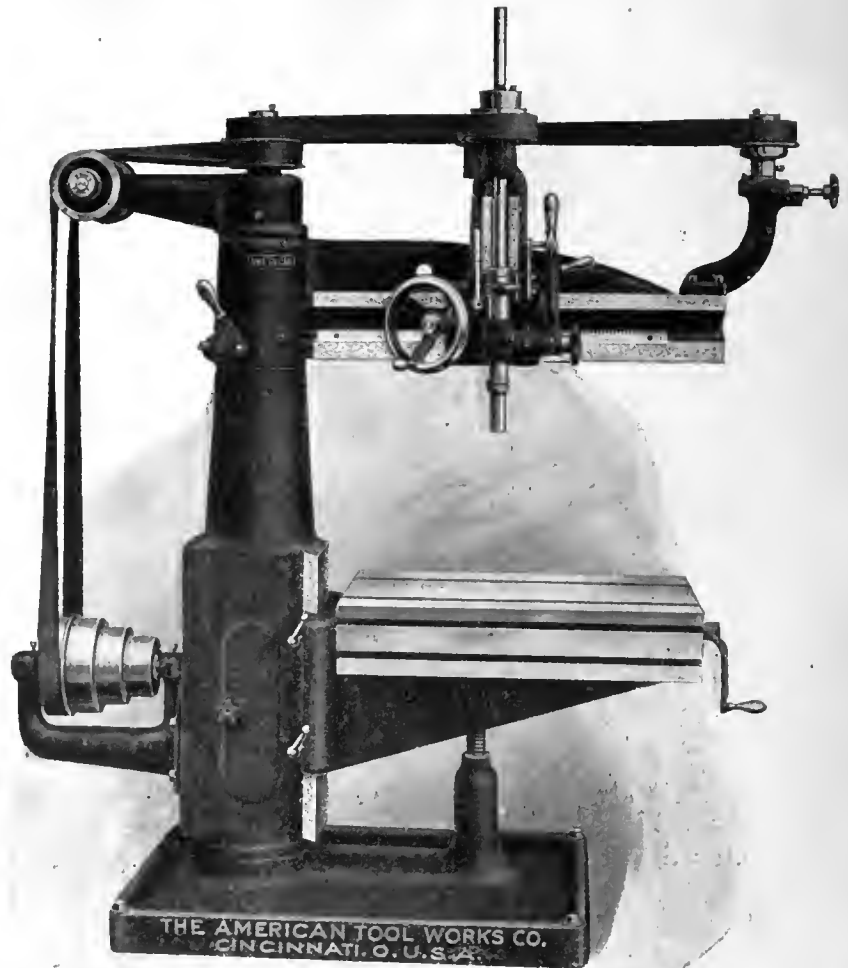

"AMERICAN" SENSITIVE RADIAL DRILL WITH ELEVATING TABLE.

adapted for cutting face or barrel cams, also for the use of lubricant. The design follows closely their standard as used on the 24-inch and 36-inch sized machines. The spindle slide is very sen-

bearings are of a style similar to those used in proflers. Provision is made for the instantaneous reversal of the feed, or the entire disengaging of same. The change from face to barrel cam fixture is also quickly made; the barrel cam fixture being shown on the floor in one of the illustrations and in place in the other.

equipped works at Coventry, are producing a number of machine tools which should prove of interest throughout the Dominion. One of the lines in which they have particularly specialized is shaping machines, which they make in seven sizes of a standard pattern, ranging from 10in. to 30in., together

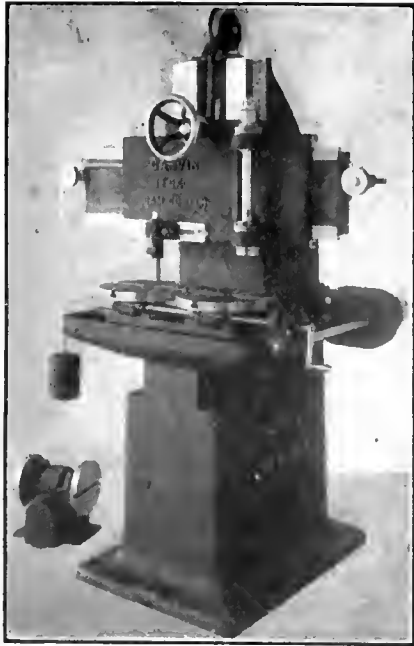

12-INCH CAM CUTTING MACHINE.

sitive, running on large balls in steel tracks, while the drive is by universal joint from overhead counter. The rail-slide is accurately balanced and operated by rotary nut with ball thrust, giving a quick motion for the removal of cutter and former pin on the completion of the cam; the spindle slide being clamped in position while making the change, returning to a positive micrometer stop. All gears are protected, and the spindle

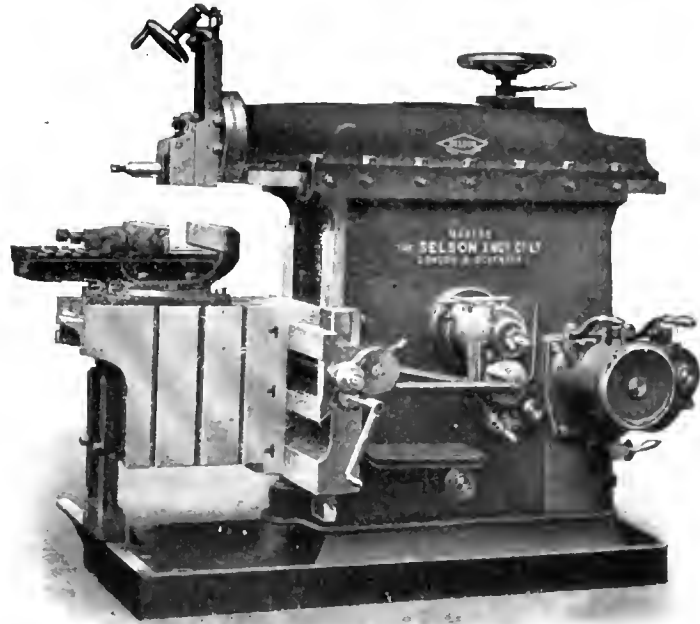

SELSON HIGH SPEED HEAVY DUTY SHAPER.

A WELL KNOWN LINE OF BRITISH MACHINE TOOLS.

THE Selson Engineering Co., of 85 Queen Victoria Street, London, England, who have modern and well-

with two of a special type. The following advantages are claimed for this line:—

1. The position of the ram is adjusted by means of a rack and pinion, by a



12-INCH CAM CUTTING MACHINE.

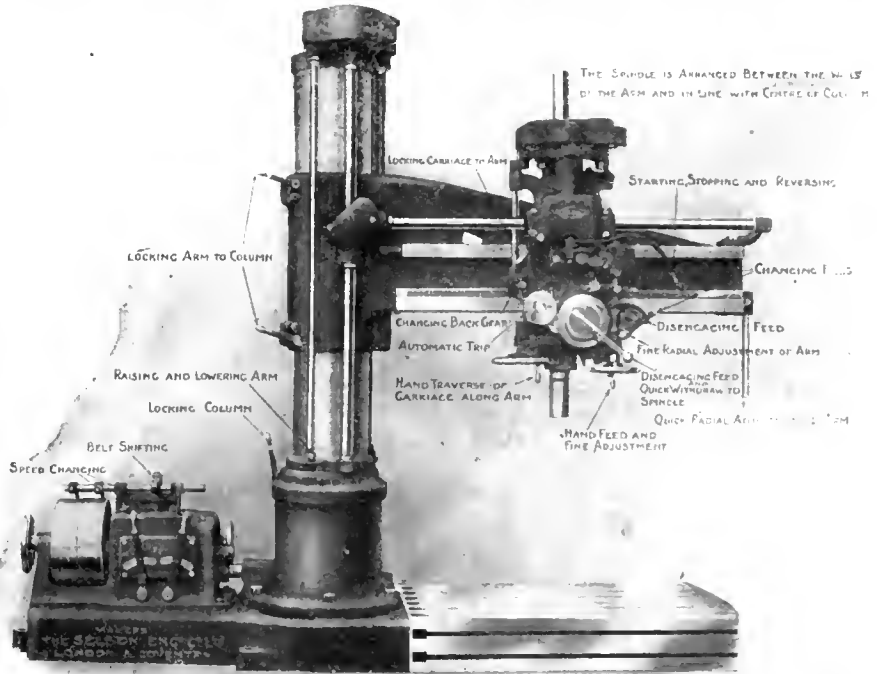

SELSON 6 FT. CENTRAL THRUST RADIAL DRILL.

hand wheel which is mounted on the same centre as the locking handle.

2. The ram is clamped to the crank by means of a serrated slide.

3. The main driving link is connected to the ram by a short link, thus imparting a draw stroke and a uniform cutting speed to the ram.

4. The index for the length of the

alterations are made is stationary.

The special type shaping machines are designed specially for operating on large work, as the table can be swung aside on a pivot, and the work directly mounted on the lower table, an automatic cross feed being provided on the head. In other respects the construction is the same as the standard types and the

machines are that the centre line of the spindle being always in line with the centre of the column, no twisting strains are imposed on the arm, the thrust being taken up equally on each wall. The patent lies in the fact that a third bearing for the carriage is introduced on the top of the front wall, and takes the hanging weight of the

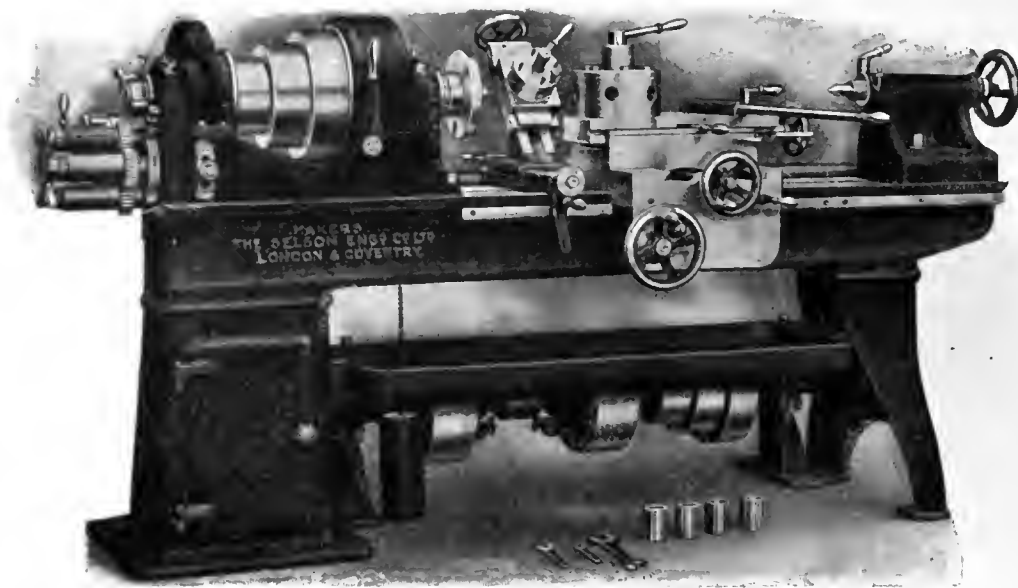

SELSON PATENT BRASS FINISHERS' LATHE.

stroke is mounted on a stationary index at the side of the machine immediately above the adjusting handle, so that the length of stroke can be set, either while the machine is in motion or while it is stationary, to any definite length.

shaper can be used with the automatic traverse to the table.

Radial Drills.

Another line which the Selson Engineering Co. have specialized in, is their radial drilling machines. These

saddle also the gear wheels on the top of the spindle for the back gears are taken from this bearing.

The machine is provided with an automatic stop and on the 6ft. machine a special arrangement is added for fine radial adjustments of the arm.

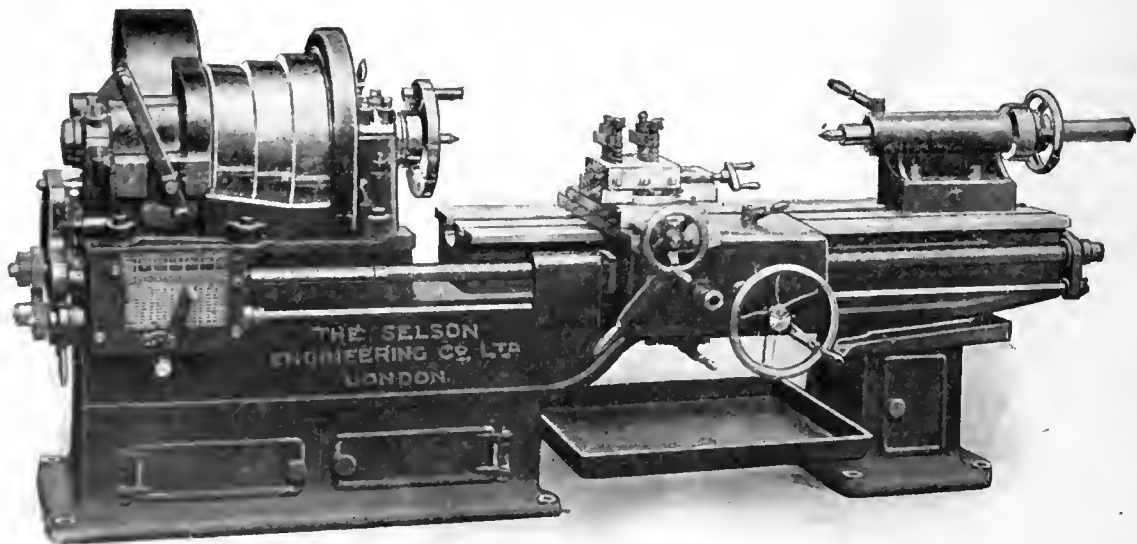

SELSON 17-INCH SWING HIGH SPEED ENGINE LATHE.

A patent feature on the machine is that for altering or reversing the feed, the whole of the feed motion can be stopped by depressing a lever and the alterations made while the machine is in motion. The index on which the

are made in the Universal type with swivelling arm and swivelling saddle with 4ft. radius, and the new patent central thrust types, in the 4 ft. 6 in. and 6ft. sizes. The principal advantages claimed for these central thrust

The clutches for starting and reversing the spindle are arranged so that when the clutch is put in the bevel gears are driven round by a friction and when the speeds of the shaft and bevels are approximately the same, the

drive is taken up by a positive dog clutch.

Engine Lathes.

The high speed engine lathes manufactured by this Company are exceedingly powerfully built. They have a three stepped cone pelley, the largest step on the 17in. swing lathe, being 18in. diameter and the smallest 14 inches. The lathes are fitted with double back gears and two speed counter-shaft, 18 spindle speeds being thus obtained.

The end thrust on the lead screw is taken up on adjustable ball bearings. This is a great advantage when heavy threads are cut, as considerable friction is caused by the heavy thrusts on the end of the guide screw.

Monitor Lathe.

The Company also manufacture a patent brass finishers' lathe, which carries four hobs and chasers of different pitches, mounted on a turret. By simply revolving the turret four different threads may be cut. The chaser being also fitted with an auxiliary turret carrying four tools, internal threads of different pitches can be as readily cut.



BARNES NO. 5 GAP LATHE.

THE small gap lathe here shown is well suited for amateurs, jobbing shops and light work generally, and is a production of the W. F. & John Barnes Co., Rockford, Illinois. It is a screw cutting lathe, equipped with compound rest and off-set type of tail stock, permitting the compound rest to be set parallel with the bed. The head-stock boxes are accurately fitted to the spindle with provision for keeping them true and for taking up wear. Spindles of both head and tail stocks are of steel, with true taper holes for the reception of the centres; the tail stock centre is self discharging. The compound table has tee slots, and is thus adapted for clamping

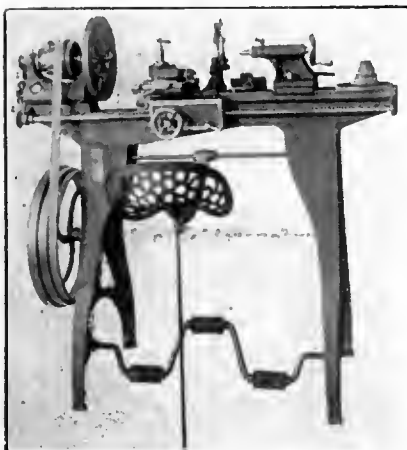

BARNES NO. 5 GAP LATHE.

work for boring and milling operations.

All the mechanisms are securely protected from chips and dirt, thus insuring long wear and durability to the most vital parts of the lathe. The gearing furnished can be combined to make different leads of threads from 4 to 40, besides many others not mentioned on the

may be drilled in each of two separate pieces. It is not necessary that the two holes should be directly opposite one another, since in the machine illustrated, the right hand spindle is provided with six inches of cross traverse. The lathe is also built without this latter feature when desired.

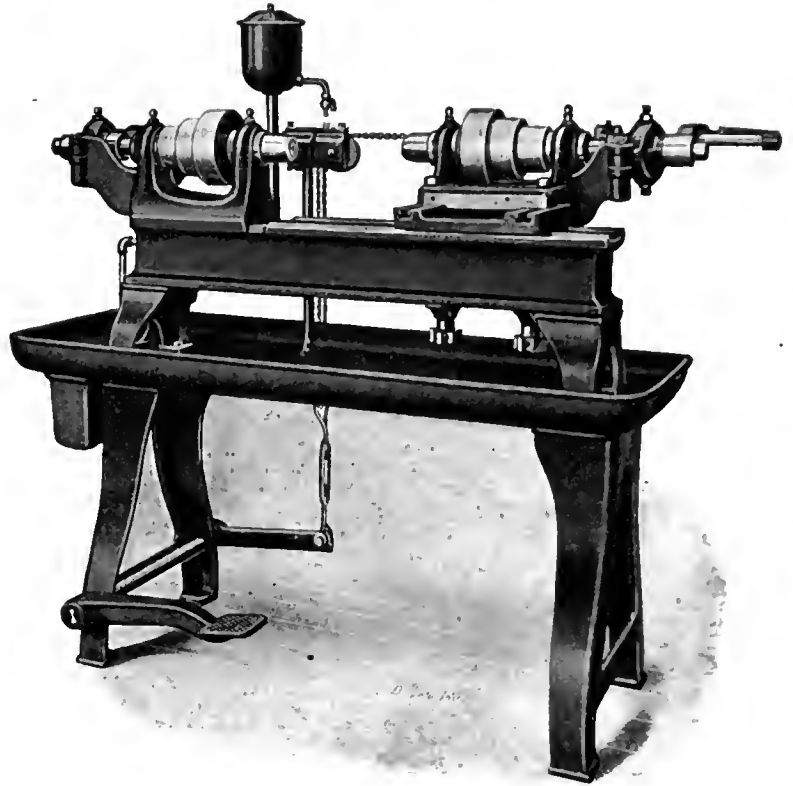

TWO SPINDLE DRILLING LATHE.

index plate. All the gearing is cut from solid metal, and is as true and noiseless as it is possible for metal gearing to be.

This lathe swings 11 inches over the bed and 15 inches in the gap, which is 5 inches wide, measured from the face plate. The swing over the saddle is 6 5/8 inches and the distance between centres 29 inches. The drive is by countershaft or foot-power, as desired. For the latter, either a velocipede or stand-up treadle can be supplied.



TWO-SPINDLE DRILLING LATHE.

THE interesting two-spindle lathe here shown is a recent development of the F. E. Wells & Son Co., Greenfield, Mass. This lathe is a little out of the ordinary and would seem to give promise of considerably reduced drilling cost.

The construction is clearly seen from the cut. The purpose, of course, is the drilling or counterboring of two holes on opposite sides of a piece, or by the use of a suitable jig or fixture, one hole

Both spindles are brought forward by the foot treadle, coil springs pulling them back when the treadle is released. Draw-in collets are recommended for holding the twist drills, as the latter can then be ground down shorter than if held in an ordinary drill chuck.

The swing over the ways is 12 inches, and the distance between spindles is 16 inches. The spindles run in taper bronze ring oiling boxes and are 1 5/8 in. in diameter by 3 1/4 in. long. The lathe is built with back gears when desired, in which case, a two-step cone pulley is provided in place of that shown in the illustration.



C.P.R. ANGUS SHOPS, MONTREAL.

THE Angus Shops of the Canadian Pacific Railway at Montreal had an immense output of rolling stock during 1912. It reached a total of 17,357 vehicles of every class. Included in this total were 248 passenger cars of all kinds; 16,693 freight cars; 119 snow plows, steam shovels, pile drivers, etc., and 297 locomotives.

The MacLean Pub. Co., Ltd.

(ESTABLISHED 1888.)

JOHN BAYNE MACLEAN - - - - - President
H. T. HUNTER - - - - - General Manager

PUBLISHERS OF

CANADIAN MACHINERY AND MANUFACTURING NEWS

A weekly newspaper devoted to machinery and manufacturing interests, mechanical and electrical trades, the foundry, technical progress, construction and improvement.

H. V. TYRRELL - - - - - Business Manager

PETER BAIN, M.E. - - - - - Editor

J. H. WILLIAMS - - - - - Associate Editor

OFFICES:

CANADA

Montreal, Rooms 701-702 Eastern Townships Bank Bldg.

Toronto, 143-149 University Ave., Phone Main 7324

Winnipeg, 34 Royal Bank Bldg., Phone Garry 2313

Vancouver, 11, Hodgson 2649 Third Ave. West.

GREAT BRITAIN

London, 88 Fleet Street, E.C. Phone Central 12960
E. J. Dodd

UNITED STATES

New York, R. B. Huestis 115 Broadway, New York, N.Y., Phone 2209 Rector

Chicago, A. H. Byrne Room 607, Marquette Bldg. 140 S. Dearborn St., Chicago

CABLE ADDRESS:

Macpubco, Toronto. Atabek, London, Eng.

SUBSCRIPTION RATE:

Canada, \$2.00; United States, \$2.50; Great Britain, Australia and other colonies, 8s. 6d. per year; other countries, \$3.00. Advertising rates on request.

Subscribers who are not receiving their paper regularly will confer a favor on us by letting us know. We should be notified at once of any change in address, giving both old and new.

Vol. IX. FEBRUARY 6, 1913 No. 3

PRINCIPAL CONTENTS.

Industrial Development of the Maritime Provinces	97-99
Steam Hydraulic Farging Presses	100-101
General	101-102
Coal Versus Oil...Increased Locomotive Efficiency.... Opening of the Transcona Shops.	
Some Principles of Successful Storekeeping	103-104
Grinding and Scraping Compared	105-106
General	106
Hot Panel and Hot Floor Border System of Heating ...Steel Company and Fort William...Wagon Company Wound-up.	
The United States Steel Corporation and Canada	107-108
General	108-113
Canadian Railroad Co. Expenditures...Canadian Agricultural Implements in Australia...The Development of St. John, N.B....Let the Facts be Known...Cheaper Iron for the West...Canadian Iron & Foundry Co.... C.P.R. 1913 Requirements...Uniformity of Specifications ...When Steel Freezes...C.N.R. Orders...Natural Gas in I.C.R. Workshops...Canadian Shipbuilding Development ...Hardening Twist Drills and Taps...Shipbuilders Want Subsidy...Standardization of Parts... Increased Mileage Between Tire Turnings...The Training of Salesmen...Cutting and Generation of Gear Teeth.	
Recent Judicial Decisions	113
General	114
Steel Belts for Power Transmission...The Modern Gas Producer...A New Alloy of Iron that is Rustless... Electrification of Railways...Statistics of Canadian Industrial Centres.	
Machine Shop Methods and Devices	115-117
A Graduating Fixture...A Crank Shaft Turning Jig... A Milling Machine Turret...Gear and Pulley Drilling and Reaming Fixture.	
Developments in Machinery	118-121
High Speed Sensitive Radial Drills...12-inch Cam Cutting Machine...A Well-known Line of British Machine Tools...Barnes No. 5 Gap Lathe...Two Spindle Drilling Lathe.	
Editorial	122
Industrial and Construction News	123-127
Selected Market Quotations	128-129

"CANADIAN MACHINERY" A WEEKLY.

THE present number of Canadian Machinery marks its establishment on a weekly basis, and no more convincing evidence need be forthcoming of the steady development and successful enterprise relative to the production of mechanical equipment in Canada for general manufacturing and industrial purposes, than the demand from mechanical men, the Dominion over and beyond, for an increased and larger service than we have heretofore offered. Our journal has recently been increasingly recognized as not only the leading medium in the particular field of machine tool manufacture, foundry and general workshop practice, but has, in addition, been foremost in giving prominence to those supplemental contributories which determine efficiency of operation and consequent production economy. The foregoing references apply equally to the editorial and advertising sections of our Paper, each sharing the credit of accomplishing definite and highly satisfactory results from a gratifyingly large body of manufacturers, superintendents, foremen, draughtsmen and operative mechanics.

Weekly publication will naturally still further tend to increase the value of our Journal, for not only will each issue contain the usual attractive features of the monthly, but there will be found added selected and current market reports and clearly printed and displayed industrial developments and projects, calling for erection, equipment and installation.



THE BESSEMER CENTENARY.

THIS year witnesses the one hundredth anniversary of the birth of Henry Bessemer whose name will as assuredly be honored by posterity as are those of Watt, Stephenson and other great pioneers of engineering.

It is not too much to say that Bessemer's invention of the converter process of steel making has completely revolutionized modern life. Everyone now freely admits this, although at the time the discovery of the process was announced, there was not wanting the usual swarm of critics who freely decried the invention. Such, however, has been the history of all great discoveries. It is hard for us to put a true value on current events, we either under or over estimate their importance.

Our English contemporary, "Engineering," in the issue just to hand, has an interesting article on the life of Sir Henry Bessemer, from which we quote the following:—

Bessemer's work introduced an era of cheap production, without which our present conditions of existence would be impossible. The quickening of the pace, so noticeable of recent years, has been due to increased facilities of production, construction, and transport, all of which received an unprecedented impetus as a result of his work. It is difficult now to foresee any remaining direction in which a similar change could be brought about in the future; but on this point we do not propose to speculate. In several quarters at one time there might have been heard opinions unfavorable to Bessemer's work, but, in spite of such, it has played its part magnificently in the world's progress. We may also fall into the like error if we attempt to forecast the future of developments proceeding around us every day.

The era of steel, Bessemer's great bequest to mankind, has been put to such good purpose in the last forty or fifty years that the whole world has changed. Inter-course has increased; commerce has expanded, and incalculable benefits have followed in its train.

INDUSTRIAL ^A_N^D CONSTRUCTION NEWS

Establishment or Enlargement of Factories, Mills, Power Plants, Etc.; Construction of Railways, Bridges, Etc.; Municipal Undertakings; Mining News.

Engineering

Owen Sound, Ont.—An extension is being added to the William Kennedy and Sons Foundry here.

Chatham, Ont.—An auto wheel factory, cost \$40,000, is planned for the Chatham Auto Wheel Co.

London, Ont.—The G.T.R. lines at Windsor will be relaid with 100lb steel, the work to start in the Spring.

Windsor, Ont.—Fire did \$6,000 damage to the Dominion Stamping Works, at Walkerville, Ont., on January 31.

Preston, Ont.—The Preston Car and Coach Co. will add four more shops to its plant, thus doubling its capacity.

Watrous, Sask.—The Farmer's Machine Co. will commence operations in their new factory as soon as power is supplied.

Transcona, Man.—The first engine has been taken into the G.T.P. shops, and two hundred mechanics have arrived from Rivers.

Winnipeg, Man.—A company here have made an offer to the Hercules Rotary Engine Co., Ltd., to manufacture their speciality.

Calgary, Alta.—The plant of the Western Iron Manufacturers, Ltd. went into operation, February 1. Thirty men are employed.

Saskatoon, Sask.—The Western Foundry & Machine Co. was gutted by fire recently, the loss of \$25,000 being covered by insurance.

Orillia, Ont.—The works of the Canada Refining and Smelting Co., which were partially destroyed by fire recently, will be rebuilt without delay.

Sarnia, Ont.—An extension to their stove factory on Wellington and Vidal Streets, by the Doherty Mfg. Co., 157 Vidal Street South, is planned.

Belleville, Ont.—The manufacture of steel will be commenced here by the Twain Electric Steel Co. The company have secured mines in Hastings County.

Dunville, Ont.—The Canadian Engines Co. is having plans drawn for a large addition to be made to its plant for the manufacture of gas and gasoline engines.

Brandon, Man.—The Brandon Wire and Stamp Co., organized by eastern capitalists for the manufacture and distribution of metal goods, is about to start operations.

Pembroke, Ont.—The Alexander Barr Co., Pembroke, Ont., will need new equipment for their factory which was

burned recently. Several new forges will be installed.

Fort William, Ont.—The first two car loads of structural steel for the construction of the Canadian Car and Foundry Co.'s plant, arrived on Thursday, January 18.

Edmonton, Alta.—Austin J. Bruff, a representative of the Union Metallic Cartridge Co., Bridgeport, Conn., has announced that his firm will establish a branch factory here.

Strathroy, Ont.—The Royal Motor Co. will build their new plant at Strathroy, Ont., early in the spring. They will employ about 300 men and Mr. J. G. Dunn is the president.

Sydney, N.S.—The Sydney Foundry and Machine Co., Ltd., Sydney, N.S. contemplate installing new forging equipment, traveling crane and latest type of casting machinery.

New Westminster, B.C.—Preparations are being made on Lulu Island, to build a new plant for the Heaps Engineering Works. Piles are being driven for the machine shop and other buildings.

Guelph, Ont.—The International Sand, Lime, Brick and Machinery Co., of Montreal, will start at once to build a plant at Guelph, Ont., costing \$90,000, employing 50 men to begin with.

Vancouver, B.C.—Contracts have been awarded exceeding \$1,200,000 for machinery, plant and structural steel in connection with the smelter to be erected at Granby Bay, Portland Canal district.

Montreal, Que.—Twenty-five heavy Mikado type locomotives recently ordered by the Grand Trunk Railway from the Montreal Locomotive Works, Ltd., will be equipped with vanadium steel frames.

Sydney, N.S.—The Cape Breton Electric Co., Sydney, N.S., will spend \$200,000 on new equipment, including for a machine shop, also on railway motors, new telephone system and a ferry boat.

London, Ont.—The Guelph Tool Company, T. S. Hobbs, manager, have secured a site here, upon which they will erect a factory for the manufacture of tools and hardware specialties. Estimated cost, \$50,000

London, Ont.—Chisholm Dunn Telephone Appliances, London, Ont., contemplate the purchase of machinery and equipment required for manufacturing telephone receivers, transmitters, etc., also stock required in the manufacture of brass and nickel goods, etc.

St. John, N.B.—T. McAvity & Sons are prepared to erect a group of 30 buildings and give employment to a thousand workers in the iron and brass industries when the city has its new industrial area ready for locating upon.

Montreal, Que.—The Dominion Steel Corporation has ordered additional machinery to increase the capacity of its wire and nail plant, which has been recently put on double turn. This will give at once an output of over 2,000 kegs daily and ultimately provide an outlet for the whole of the product of the wire rod mills.

Hespeler, Ont.—Hespeler is to have a new industry this spring. A company has been formed, at the head of which is Hon. Geo. A. Clare, M.P., of Preston, and other Waterloo and Toronto capitalists, to manufacture galvanized iron and steel household wares. The new factory will use the old woollen mills buildings, which ten years ago, ceased operations on account of an unfavorable tariff.

Shippegan, N.B.—Tenders for the purchase of the reduction works plant and property at Shippegan, N.B., will be received until noon of February 12th, 1913, at the office of A. Johnston, Deputy Minister of Marine and Fisheries, Ottawa. The plant consists of an office building, reduction works proper, warehouse and forge. Plant is equipped with a boiler, engine, feed water heater, boiler feed plmp, fire protection and general service pump, fish drier, and all the necessary fittings in connection with same.

Victoria, B.C.—Tenders will be received up to noon of Saturday, February 15th, 1913, for the purchase of the engines and boilers with fittings at pumping stations No. 1 and No. 2 Matsqui. The plant at each station consists of one 16-in. by 36-in. Hamilton Corliss engine, one Babcox and Wilcox water tube boiler about 180 h.p., one duplex boiler feed pump, one separator, one jet condenser, etc. Full particulars may be had on application to Mr. D. McCaskill, caretaker, residing on dyke near pumping station No. 1, or E. A. Wilmot, Inspector of Dykes, office of Inspector of Dykes, Victoria.

Municipal

Summerside, P.E.I.—A steel bridge was opened on Friday, Jan. 10, at Montagne.

St. Catharines, Ont.—The C.N.R. will build into this city, and will erect a high-level vehicular bridge across the old canal.

Sydney, N.S.—Owing to last year's disastrous drought the capacity of the water works plant must be increased to connect other lakes with the present supply, a pipe line and pumping station will be required.

Prince Albert, Sask.—The council have agreed to make a temporary loan of \$400,000 in order that the development work on the civic power plant at Laeille Falls, on the Saskatchewan River may be proceeded with.

Saskatoon, Sask.—By-laws to issue \$150,000 for electric light extensions; \$20,000 for fireproofing pumping station; \$50,000 for fire equipment, and \$70,000 for the purchase of an incinerator, will be voted on this month.

Calgary, Alta.—The city commissioners intend recommending to the city council that the sum of \$11,100 be spent on the purchase of a pump to be installed on the intake on the Bow River.

Toronto, Ont.—The Board of Control have recommended to the city council that the tender of the Turbine Equipment Company, of New York City, for a 15,000,000 gallon pump for the Waterworks System, be accepted. The tender price was \$44,000.

Electrical

Ottawa, Ont.—The Ottawa Electric Railway will extend its lines in the spring. Twenty new cars will also be required.

Assiniboia, Man.—This municipality is planning to install an electric light plant this year. The secretary is Frank Ness, Kirkfield Park, Man.

St. John, N.B.—The New Brunswick Hydro-Electric Co., will, during the year make a large expenditure in connection with its project to provide another source of light, heat and power.

Hamilton, Ont.—The Dominion Power Transmission Co. is considering the purchase of twelve double-truck cars for use on the Hamilton Street Railway.

Winnipeg, Man.—A 9,000 k.w. 3 phase step-up transformer is required at Point du Bois power house. Tenders to Chairman of Board of Control before Feb. 14.

Welland, Ont.—The town council have authorized the purchase of the Ontario power plant, and will use it in connection with the Hydro-Electric System. The price is \$26,350.

Orillia, Ont.—The town intends to sell its power dam to the Dominion Government for about \$100,000. With the money a new power plant will be built, capable of supplying four thousand horse power.

Sault Ste. Marie.—The H. E. Talbot Company, of the Soo, have been awarded the contract for the construction of a 1,500-foot dam and the installation of a complete hydro-electric system at Grand Mere, Que.

Thornbury, Ont.—The Forbes Bros., of Seaforth, Ontario, have the contract for the erection of poles and installing telephones for the Beaver Valley Municipal Telephone System. They commenced operations last week.

St. Catharines, Ont.—The city council have received a quotation from the Hydro-Electric Commission of \$14 per horsepower for 2,000 horsepower, the city to install a transformer station and system, estimated to cost \$15,000.

Brandon, Man.—The city council have awarded the contract for machinery for the power plant in connection with the street railway system to the highest of the three tenders sent in—that of the Canadian General Electric Co. for \$15,750.

St. Thomas, Ont.—Surveyors for the new Hydro-Electric power line from this city to Windsor, started work on the St. Thomas end on Thursday, Jan. 2. The line will run through Dutton, West Lorne, Rodney, Ridgetown, Chatham and Kingsville.

Estevan, Sask.—A company capitalized at \$2,500,000 will buy coal land near here, and will generate power from engines using coal gas. Machinery will be required this summer. Mr. Geo. D. Casson, publicity commissioner, Estevan, is handling the matter.

Port Alberni, B.C.—Messrs. Quinn & Rowley, of this city, have been given the contract to install the lighting system in Port Alberni, the price being \$10,000.

Prince Albert, Sask.—The commissioners of this city were authorized to purchase two new 300 h.p. Babcock and Wilcox boilers and a new turbine exciter for the enlargement of the present power plant. Preliminary steps were taken towards the erection of a larger power house in another portion of the city.

Saskatoon, Sask.—The Saskatoon Electric Railway have been asked by the town of Sutherland, about two miles from here, to extend its line there. Sutherland is also considering the installation of an electric light and power plant to be owned and operated by the municipality.

General Industrial

Vancouver, B.C.—The American Can Co. have taken over the Cliff Canning Co. of East Burnaby, and will move their plant to this city. The latter com-

pany sold their machinery, stock-in-trade and good-will for \$200,000.

Moose Jaw, Sask.—The Western Canadian Brush Mfg. Co. has arranged for a factory site here.

Maisonneuve, Que.—A shoe factory is contemplated for the Smarton Shoe Co. of Quebec, 245 ft. by 230 ft.

Calgary, Alta.—The Burns Packing Co. will erect a new factory to replace that destroyed by fire recently.

South Vancouver, B.C.—Two incinerators, costing \$60,000, have been recommended by the health committee.

St. Catharines, Ont.—W. J. Brigger, of Hamilton, has been granted partial exemption for a \$45,000 jam factory.

London, Ont.—An Aurora, Illinois, concern has bought out the Chelsea Green Hardware Co., and will operate here.

Fort Frances, Ont.—R. Bruce & Son are preparing to make some additions to the firm's tie-cutting plant at this point.

Sydney, W.S.—The Cross Fertilizer Co., Ltd., Sydney, N.S., will spend \$80,000 on an extension and machinery this year.

St. John, N.B.—The Edward Partington Pulp and Paper Co. will increase the capacity of its pulp mill by 50 per cent.

Toronto, Ont.—The Hinde & Dauch Paper Co. are putting up a four-storey brick and steel factory here, to cost \$80,000.

Prince Albert, Sask.—A creamery will be erected here. J. F. Hansen has approached the Board of Trade with the proposition.

Edmonton, Alta.—The City Commissioners have decided to spend \$50,000 or \$60,000 upon machinery for a street paving plant.

Prince Rupert, B.C.—The Cold Storage Company will erect a fertilizing plant this spring, and possibly a fish canning factory.

Dundas, Ont.—The Wentworth Orchard Co., of which Dr. A. C. Caldwell is president, will erect a jam factory at Waterdown, Ont.

Kingston, Ont.—The American Creosote Paving Co. will build a plant here, if the harbor is dredged to allow their shipping to come in.

Edmonton, Alta.—The Acme Brick Co., operating a plant six miles west of Edmonton, Alta., will spend \$250,000 on additional equipment.

Berlin, Ont.—S. A. Brubacher, of this city, will manufacture motor washing machines, for which purpose a good-sized shop has been erected.

Toronto, Ont.—The Dominion District Steam Heating Co. asked the controllers recently for a franchise to supply steam through an underground system.

Red Deer, Alta.—The Great West Lumber Co., Ltd., are preparing to add considerable machinery to their mill

here. This will include a lathe mill, a resaw and a new boiler.

Fort William, Ont.—The Board of Trade will consider a proposition, with much capital behind it, for the installation of a gas plant in this city.

Fort William, Ont.—An extension to their elevator is planned by the Western Terminal Elevator Co. Capacity to be increased by 1,000,000 bushels.

Lethbridge, Alta.—A broom factory is to be added to the jail the Provincial Government maintains here, and machinery is to be put in at once.

Winnipeg, Man.—The H. B. Reinforced Brick Work Co. will establish a factory at Winnipeg in the near future. Sten Lund, of Winnipeg, is president.

Burlington, Ont.—A fire in the boiler room is supposed to have been the start of a big blaze which completely destroyed the basket factory of J. W. Dalton on January 26th.

Blenheim, Ont.—A canning factory, cost \$40,000, on Talbot Street, is planned for the British Canadian Canners, Ltd.; manager, John Wall, 34 James Street, N. Hamilton.

Calgary, Alta.—The B. B. Rich Cut Glass-Mfg. Co. is preparing to establish here a factory that will employ about fifty men to start with. The president of the concern is R. T. Brooks, of Philadelphia.

St. Catharines, Ont.—The B. F. Goodrich Co. of Akron, Ohio, will establish a Canadian branch here, to employ a thousand hands. The city has given 17 acres of land, fixed assessment of \$10,000 for ten years, and the privilege of taking water from the canal.

Montreal, Que.—The St. Lawrence Pulp and Lumber Corporation, with a capitalization of \$4,000,000, will establish a \$2,000,000 pulp and paper plant in Quebec province. The offices will be at New Carlisle, Bonaventure County, and its limits at Grosse Pabos, Gaspe Peninsula.

Walkerton, Ont.—The Canada Saddlery Hardware Co. have asked the Town Council to submit a by-law to the ratepayers of the town granting them a loan of \$10,000. This company was established about six months ago, and the \$10,000 capital stock subscribed for was expended in putting the factory in running order.

Gananoque, Ont.—Plans are being prepared by Cowan & Britton, Ltd., Gananoque, for enlarging their plant to three times the present size, for the manufacturing of all descriptions of builders' hardware, specializing tee and strap hinges and butts of all kinds. The building of the new plant will begin in the spring. Presses for stamping butts and hinges and other hinge and butt machinery will be purchased.

Saw and Planing Mills

Battleford, Sask.—The Galvin Lumber Works, Ltd., will establish a branch here.

St. John, N.B.—Haley Bros. & Co., have applied for a site upon which to erect a woodworking plant.

Fort William, Ont.—Fire did a thousand dollars damage to the C.P.R. carpenter shop on Monday, Jan. 13.

Regina, Sask.—J. A. Menzies, will erect a sawmill at Merritt in the spring. He will purchase a new boiler and engine, and some other machinery.

Calgary, Alta.—The wood-working plant of the J. M. Bateson Co. was reduced to ashes on Sunday, Jan. 19. The loss was \$60,000, including \$30,000 worth of fixtures for the new Hudson Bay store. The plant will be rebuilt.

Building Notes

London, Ont.—The International Harvester Co. will build a large warehouse here.

Nanaimo, B.C.—The Nanaimo Amusement Co., Ltd., will build a handsome theatre here.

Toronto, Ont.—The Shea Syndicate will build a new vaudeville house to seat 3,000 people.

Saskatoon, Sask.—The Calgary Brewing Co. will, it is rumored, build a plant here in the spring.

Winnipeg, Man.—Plans for 200 additional rooms to the Royal Alexandra Hotel have been completed.

Weyburn, Sask.—The Weyburn Club will be incorporated shortly, and premises costing \$25,000 erected.

Ottawa, Ont.—Tenders for the new Customs House will be called for shortly. Excavating is now going on.

Hamilton, Ont.—It is rumored that the C.P.R. will spend a million and a half dollars on an office building here.

Vancouver, B.C.—Mr W. G. Elliott will erect a \$30,000 apartment house at the corner of Sixth Ave. and Alberta St.

Toronto, Ont.—The Temple Pattison Co., makers of dental supplies, will erect a five-storey warehouse at 243 College Street.

Vancouver, B.C.—The Standard Trust & Industrial Co. will build a four-storey reinforced concrete building costing \$45,000.

Victoria, B.C.—Sealed tenders have been invited for the construction of the new jail. Bids were received up to January 28.

Saskatoon, Sask.—The contract for the three-storey Ash-McGowan building has been awarded to the George H. Archibald Co.

Victoria, B.C.—Permits for two apartment blocks have been taken out by Par-

fit Bros. Sums of \$11,000 and \$40,000 are to be spent on them.

Ottawa, Ont.—Tenders for Montreal Postal Station "H" will be received at the Department of Public Works until Monday, February 10.

Toronto, Ont.—Messrs Teagle & Son secured the contract for the masonry work on the new Keele St. public school. Their price was \$38,800.

Victoria, B.C.—The Victoria Warehouse Co., Ltd., took out a building permit recently to construct an addition to warehouses costing \$8,000.

Toronto, Ont.—The Methodist Book Room board will erect a \$1,000,000 building on the site at the south-east corner of Queen and John Streets.

Prince Albert, Sask.—It is stated that the Canadian Northern Railway will erect a large hotel here, at a cost of between \$250,000 and \$500,000.

Winnipeg, Man.—It has not yet been decided whether the grain elevator at McLean, Sask., which was burned down on Tuesday, Jan. 21, will be rebuilt.

Toronto, Ont.—The A. B. Ormsby Co. have amended plans for their proposed new factory for manufacturing metal window sashes. It will be 50 feet high.

Toronto, Ont.—Messrs Hyman, Simon and Henry Franklin have bought land in Toronto, and will build a five-storey warehouse on the Queen and Portland St. corner.

Winnipeg, Man.—Tenders are being called for a new factory building for the Smart-Woods, Ltd., bag manufacturers. It will be five storeys and basement, and 147x98 feet.

Vegreville, Man.—A large building will be erected here to accommodate stores, opera house, offices and moving picture show. It will be 60x100 feet, costing \$25,000.

Vancouver, B.C.—The Canadian Brewing Co. have awarded the contract for the erection at a cost of \$70,000 of a four-storey brick and steel addition to their premises on Yew Street.

Berlin, Ont.—It is proposed by the Government to erect a new Federal Building at an estimated cost of \$200,000. The present post office will be used as a customs and excise office.

Toronto, Ont.—Thirty-two tenders were received for the construction of the Technical School, but only the five lowest wanted the contract for the entire work. The lowest tender was \$1,219,000—\$400,000 more than the appropriation.

Toronto, Ont.—The Canadian Bank of Commerce has acquired, or is about to acquire, the Manning Estate, on which the McConkey Restaurant stands, and will erect a new building. Darling & Pearson are their architects.

McLeod, Alta.—The first building permit this year was given to the Calgary

Personal

City Engineer Wilson, of Fort William, Ont., recently sent in his resignation, which was accepted at a meeting of the Council on Friday, January 21.

John F. Curry, who for twenty-four years has been an important official of Canada Car and Foundry Company, Co. wiersst, N.S., has lately been appointed to the sales department of that South Vance.

John G. Powell, of Toronto, has been named by the heat principal assistant

St. Catharines, Ont.—City engineer, of Hamilton, has been given \$2,700 to exemption for a \$45,000 jan. offer to go

London, Ont.—An Aurora, Brks Comcern has bought out the Cheil Hardware Co., and will operate.

Fort Frances, Ont.—R. Bruce are preparing to make some additions to the firm's tie-cutting plant at the, chief

Sydney, W.S.—The Cross Frworks Co., Ltd., Sydney, N.S., will spend over \$100,000 on an extension and machine

St. John, N.B.—The Edward Pnuary ton Pulp and Paper Co. will increase the capacity of its pulp mill by 15 per cent.

Toronto, Ont.—The Hinde & Dties Paper Co. are putting up a four-stical brick and steel factory here, to cost \$80,000.

Prince Albert, Sask.—A creamery will be erected here. J. F. Hansen has approached the Board of Trade with the proposition.

Edmonton, Alta.—The City Commas sioners have decided to spend \$50,000 or \$60,000 upon machinery for a street paving plant.

Prince Rupert, B.C.—The Cold Stout age Company will erect a fertilizing plant this spring, and possibly a first canning factory.

Dundas, Ont.—The Wentworth Orchard Co., of which Dr. A. C. Caldwell is president, will erect a jam factory at Waterdown, Ont.

Kingston, Ont.—The American Creosote Paving Co. will build a plant here, if the harbor is dredged to allow their shipping to come in.

Edmonton, Alta.—The Aemo Brick Co., operating a plant six miles west of Edmonton, Alta., will spend \$250,000 on additional equipment.

Berlin, Ont.—S. A. Brubacher, of this city, will manufacture motor washing machines, for which purpose a good-sized shop has been erected.

Toronto, Ont.—The Dominion District Steam Heating Co. asked the controllers recently for a franchise to supply steam through an underground system.

Red Deer, Alta.—The Great West Lumber Co., Ltd., are preparing to add considerable machinery to their mill

St. Catharines, Ont.—The C.N.R. will build into this city, and will erect a high-level vehicular bridge across the old canal.

Sydney, N.S.—Owing to last year's disastrous drought the capacity of the water works plant must be increased to connect other lakes with the present supply, a pipe line and pumping station will be required.

Prince Albert, Sask.—The council have agreed to make a temporary loan of \$400,000 in order that the development work on the civic power plant at Lacelle Falls, on the Saskatchewan River may be proceeded with.

Saskatoon, Sask.—By-laws to issue \$150,000 for electric light extensions; \$20,000 for fireproofing pumping station; \$50,000 for fire equipment, and \$70,000 for the purchase of an incinerator, will be voted on this month.

Calgary, Alta.—The city commissioners intend recommending to the city council that the sum of \$11,100 be spent on the purchase of a pump to be installed at the intake on the Bow River.

Toronto, Ont.—The Board of Control have recommended to the city council that the tender of the Turbine Equipment Company, of New York City, for a 15,000,000 gallon pump for the Waterworks System, be accepted. The tender price was \$44,000.

Electrical

Ottawa, Ont.—The Ottawa Electric Railway will extend its lines in the spring. Twenty new cars will also be required.

Assiniboia, Man.—This municipality is planning to install an electric light plant this year. The secretary is Frank Ness, Kirkfield Park, Man.

St. John, N.B.—The New Brunswick Hydro-Electric Co., will, during the year make a large expenditure in connection with its project to provide another source of light, heat and power.

Hamilton, Ont.—The Dominion Power Transmission Co. is considering the purchase of twelve double-truck cars for use on the Hamilton Street Railway.

Winnipeg, Man.—A 9,000 k.w. 3 phase step-up transformer is required at Point du Bois power house. Tenders to Chairman of Board of Control before Feb. 14.

Welland, Ont.—The town council have authorized the purchase of the Ontario power plant, and will use it in connection with the Hydro Electric System. The price is \$26,350.

Orillia, Ont.—The town intends to sell its power dam to the Dominion Government for about \$100,000. With the money a new power plant will be built, capable of supplying four thousand horse power.

Sault Ste. Marie.—The H. E. Tallit Company, of the Soo, have been awarded the contract for the construction of a 1,500-foot dam and the installation of a complete hydro-electric system at Grand Mere, Que.

Thornsbury, Ont.—The Forbes Bros., of Seaforth, Ontario, have the contract for the erection of poles and installing telephones for the Beaver Valley Municipal Telephone System. They commenced operations last week.

St. Catharines, Ont.—The city council have received a quotation from the Hydro-Electric Commission of \$14 per horsepower for 2,000 horsepower, the city to install a transformer station and system, estimated to cost \$15,000.

Brandon, Man.—The city council have awarded the contract for machinery for the power plant in connection with the street railway system to the highest of the three tenders sent in—that of the Canadian General Electric Co. for \$15,750.

St. Thomas, Ont.—Surveyors for the new Hydro-Electric power line from this city to Windsor, started work on the St. Thomas end on Thursday, Jan. 2. The line will run through Dutton, West Lorne, Rodney, Ridgetown, Chatham and Kingsville.

Estevan, Sask.—A company capitalized at \$2,500,000 will buy coal land near here, and will generate power from engines using coal gas. Machinery will be required this summer. Mr. Geo. D. Casson, publicity commissioner, Estevan, is handling the matter.

Port Alberni, B.C.—Messrs. Quinn & Rowley, of this city, have been given the contract to install the lighting system in Port Alberni, the price being \$10,000.

Prince Albert, Sask.—The commissioners of this city were authorized to purchase two new 300 h.p. Babcock and Wilcox boilers and a new turbine exciter for the enlargement of the present power plant. Preliminary steps were taken towards the erection of a larger power house in another portion of the city.

Saskatoon, Sask.—The Saskatoon Electric Railway have been asked by the town of Sutherland, about two miles from here, to extend its line there. Sutherland is also considering the installation of an electric light and power plant to be owned and operated by the municipality.

General Industrial

Vancouver, B.C.—The American Can Co. have taken over the Cliff Canning Co. of East Burnaby, and will move their plant to this city. The latter com-

Co. Later, the name of the firm was changed to the Montreal Steel Works, and a few years ago it was purchased by the interests of the Canadian Steel Foundries, Limited, the present title of the company, of which business Mr. Smith was general superintendent. His duties embraced the supervision and administration of the foundries in Point St. Charles, Longue Pointe, and at Welland, Ont. Throughout his long business career Mr. Smith had been associated with Mr. K. W. Blackwell, who, after severing his connection with the C. P. R., started the first concern with which Mr. Smith commenced as superintendent.

Catalogues

The Whitman & Barnes Mfg. Co., St. Catharines, Ont., have sent us an attractive folder, in which the picture of a drill holds the folder closed for mailing. It contains an argument in favor of "W. & B" drills.

W. S. Rockwell Co., New York, have sent us a copy of Catalogue No. 44, on the subject of Rockwell Tilting Crucible Melting Furnaces. It consists of two pages, yet therein, by excellent drawings and photographs, accompanied by terse reading matter, the whole system of melting non-ferrous metals is laid bare. A careful study of these two pages gives one a clear idea of what the Rockwell Furnaces consists, and how it is operated. The catalogue is a model of condensation.

Industrial Works, Bay City, Mich., have favored us with a copy of their latest catalogue of locomotive cranes, the same being a most artistic and attractive

production. The book is a collection of large size photo-illustrations of 42 industrial works locomotive cranes supplied to the United States Steel Corporation, by whom they were used in the construction of their enormous steel plants at Gary, Ind., and South Chicago, Ill. An early illustration is entitled "The Beginning of Things," and shows one of the cranes breaking ground for the foundations of one of the buildings. Successive pictures show other cranes setting concrete, erecting the steel work, etc., the progress of the work being readily followed. The illustrations are really excellent examples of half-tone work and can hardly be distinguished from photogravures. Altogether the booklet is a credit to everyone concerned in its production.

The Eugene Dietzgen Co., Chicago, manufacturers of drawing materials and surveying instruments, have issued the ninth edition of their very complete catalogue. Some idea of the size of it will be gathered from the fact that it contains over 550 pages. It is bound in cloth cover. This firm carries everything required in the drawing office, from ink to drawing tables. Their stock seems to be complete. The last portion of the catalogue is devoted to surveying instruments and accessories. They have an office in Toronto, which has been opened since their last catalogue was issued. Their goods may also be obtained in Chicago, New York, San Francisco, New Orleans and Pittsburg.

Wanderer Milling Machines are fully described in an attractive catalogue forwarded to us by the Wanderer Works,

Ltd., Schoenau, near Chemnitz, Germany. These millers are made in all types—plain, universal and vertical and are of thoroughly modern design and construction. The plain and universal types are built with cone drive and geared feeds, or with a single pulley constant speed drive and automatic longitudinal and transverse feeds. The latter type can also be supplied with an electric drive when required. On such machines the motor is carried by a cast knee solidly clamped to the column of the machine. Power is transmitted from motor to spindle by two double helical spur wheels. In this way the space occupied by the machine is considerably reduced and a smooth drive is secured, enabling accurate work to be turned out.

These machines are thoroughly well designed and constructed, and seem to follow closely along the same lines as the best American millers.

The Standard Electric Tool Co., Cincinnati, Ohio, in Bulletin V 7, issued on the first of the year, take considerable pains to show that their "Standard" high-power universal portable electric drills are the best; that they will run off any lamp socket or power circuit, both alternating and direct current of the same voltage, and will operate satisfactorily on low frequency circuits, such as 25 and 40 cycles; further, that they do not race when running light; and that consequently the drill points are not burned. The firm guarantees to make good by repair or replacement any part of their product which proves defective within a year from date of shipment.

AGENTS WANTED

MESSRS. ROYCE, LIMITED, ELECTRICAL and Mechanical Engineers, Trafford Park, Manchester, England, wish to communicate with a firm of constructional engineers in Canada who wrote them during 1912 offering their services as agents, and will be obliged if the firm in question will respond to this advertisement. (3)

PATTERNS WOOD AND METAL

Allow us to estimate. Satisfactory work guaranteed.
TAYLOR PATTERN WORKS WALKERVILLE, ONT.

DIES AND TOOLS POWER PRESSES

For Rapid Production of
Sheet Metal Stampings

W. H. BANFIELD & SONS
TORONTO, ONT.

BEATH CRANES CHAIN BLOCKS TROLLEYS OVERHEAD RUNWAYS

Solve Coal, Machinery and Merchandise Handling Problems.
Hand, Pneumatic and Electrically Operated.

Tell us what you wish to do, and we'll suggest the proper equipment for you.

W. D. BEATH & SON, Limited
Engineers and Manufacturers

20-30 Cooper Ave.

TORONTO

SELECTED MARKET QUOTATIONS

Being a record of prices current on raw and finished material entering into the manufacture of mechanical and general engineering products.

PIG IRON.

	Per Ton.	
Foundry No. 1 and 2, Mont'l. Tor'to. f.o.b., Midland	\$21	00
Foundry No, 2, Piladelphia	18	50
Bessemer, Pittsburg ..	18	15
Gray Forge, Pittsburg	17	15
Lake Superior, charcoal, Chicago	18	00
Canadian foundry, No. 1	22	50
Canadian foundry, No. 2	22	00
Middlesboro, No. 3 pig iron	21	00
Summerlee, No 2 pig iron	24	00
Carron, special	23	50
Carron, soft	23	00
Cleveland, No. 1.....	22	00
Clarence, No. 3.....	22	50
Ayresome, No. 3.....		
Jarrow	25	50
Glengarnock	26	00
Radnor, charcoal iron. 33 75	34	50
Ferro Nickel pig iron (Soo)	25	00

BILLETS.

	Per Gross Ton.	
Bessemer billets, Pittsburg ...	\$29	00
Open hearth billets, Pittsburg ..	30	00
Forging billets, Pittsburg.....	36	00
Wire rods, Pittsburg	30	00

FINISHED IRON AND STEEL.

Per pound to largest buyers:

	Cents.
Common bar iron, f.o.b., Toronto...	2.10
Steel bars, f.o.b., Toronto.....	2.20
Bessemer rails, heavy, at mill....	1.25
Iron bars, Pittsburg	1.70
Steel bars, Pittsburg, future... ..	1.40
Steel bars, New York, future.....	1.56
Tank plates, Pittsburg, future... ..	1.50
Tank plates, New York, future....	1.61
Beams, Pittsburg, future	1.50
Beams, New York, future.....	1.61
Angles, Pittsburg, future	1.50
Angles, New York, future.....	1.61
Skelp, grooved steel, Pittsburg..	1.45
Skelp, sheared steel, Pittsburg... ..	1.50
Steel hoops, Pittsburg	1.60

Toronto Warehouse f.o.b., Toronto.

	Cents.
Steel bars	2.35
Small shapes	2.50
Warehouse import, freight and duty to pay:	
Steel bars	2.05

Structural shapes	2.15
Plates	2.15
Freight, Pittsburgh to Toronto:	
18 cents a carload; 21 cents less carload.	

BOILER PLATES AND TUBES.

	Mont'l Tor'to	
	\$	\$
Plates, ¼ to ½-inch, per		
100 lbs.	\$2 60	\$2 70
Heads, per 100 lbs.....	2 85	2 95
Tank plates, 3-16 inch....	2 70	2 80
Tubes, per 100 ft., 1½ in..	9 95	10 00
" " 2 " " ..	8 65	8 70
" " 2½ " " ..	11 00	11 00
" " 3 " " ..	12 60	12 70
" " 3½ " " ..	15 75	15 80
" " 4 " " ..	20 20	20 30

BOLTS, NUTS, RIVETS AND SCREWS.

	Per cent.	
Stove bolts.....	80	& 7½
Machine bolts, ⅜ and less	65	& 5
Machine bolts, 7-16....	57½	
Blank bolts	57½	
Bolt ends	57½	
Machine screws, iron and brass	35	per cent.
Nuts, square, all sizes..	4c	per lb off
Nuts, Hexagon, all sizes	4¼	per lb off
Flat and round head....	35	per cent.
Fillister head	25	per cent.
Iron rivets	60	10 10 off
Wood screws, flathead, bright	85	10 7½ p c off
Wood screws, flathead brass	75	10 7½ p c off
Wood screws, flathead bronze ..	70	10 7½ p c off

W. I. PIPE, STANDARD—BUTT WELD.

The following are Toronto jobbers' carload and less carload discounts on pipe. (Card weight) in effect from October 11th, 1912:

	Jobbers' Carloads.	
	Black	Gal.
¼ ⅜in.	64	49
½in.	69	59
¾ to 1½in.	73½	63½
2in.	73½	63½
2½ to 4in.	73½	63½

Less Carloads.

	Black	Gal.
¼ ⅜in.	63	48
½in.	68	58
¾ to 1½in.	72½	62½
2in.	72½	62½
2½ to 4in.	72½	62½

W. I. PIPE, STNDARD—LAP WELD.

	Black Gal.	
2in.	70½	60½
2½ to 4in.	72½	62½
4½ to 6in.	74	64
7, 8, to 10in.	70½	58½
2in.	69½	59½
2½ to 4in.	71½	61½
4½ to 6in.	72	62
7, 8, to 10in.	66½	54½

W. I. PIPE, STANDARD—BUTT WELD.

	Black Gal.	
¼ ⅜ ½in.	65	55
¾ to 2in.	69	59
2½ 3in.	69	59
3½ 4in.		
4½ to 6in.		
7 8in.		
¼ ⅜ ½in.	64	54
¾ to 2in.	68	58
2½ 3in.	68	58
3½ 4in.		
4½ to 6in.		
7 8in.		

W. I. PIPE, X STRONG, P. E.—LAP WELD.

	Black Gal.	
2½ to 3in.	66	56
3½ to 4in.	66	56
4½ to 6in.	65½	58½
7 to 8in.	60½	50½
2½ to 3in.	65	55
3½ to 4in.	65	55
4½ to 6in.	63½	56½
7 to 8in.	56½	46½

W. I. PIPE, GENUINE PUDDLED IRON—BUTT WELD.

	Black Gal.	
⅜in.	59	44
½in.	63	53
¾ to 1½in.	67½	57½
2in.	67½	57½
2½ 3in.	67½	57½
¾in.	58	43
½in.	62	52
¾ to 1½in.	66½	56½
2in.	66½	56½
2½ 3in.	66½	56½

W. I. PIPE, GENUINE PUDDLED IRON—LAP WELD.

	Black Gal.	
2in.	64½	54½
2½ to 3in.	66½	56½

3½ to 4in.	66½	56½
4½ to 6in.	67	57
7 to 8in.	63½	51½
	Black Gal.	
2in.	63½	53½
2½ to 3in.	65½	55½
3½ to 4in.	65½	55½
4½ to 6in.	65	55
7 to 8in.	59½	47½

IRON PIPE FITTINGS.

Canadian malleable, 40 per cent.; cast iron, 65; standard bushings, 70; headers, 60; flanged unions, 65; malleable bushings, 65; nipples, 75; malleable, lipped unions, 65.

COKE.

Solvay Furnace Coke	\$5.25
Solvay Foundry Coke	6.50
Connellsville Furnace Coke	5.75
Connellsville Foundry Coke	6.25
All net ton f.o.b. Toronto.	

OLD MATERIAL.

Copper, light	\$13.25 to \$13.50
Copper, crucible	15.25 to 15.50
Copper, uncrucible heavy	14.25 to 14.75
Copper wire, uncrucible	14.50 to 14.75
No. 1 machine compos'n	12.50 to 12.75
No. 1 compo'n turnings	11.25 to 11.50
New brass clippings... ..	10.25 to 10.50
No. 1 brass turnings... ..	8.25 to 8.50
Heavy lead	3.75 to 3.90
Tea lead	3.50 to 3.60
Scrap zinc	5.50 to 5.70
Pure tin foil	33.00 to 35.00
All dealer's purchasing prices in New York.	

SMOOTH STEEL WIRE.

No. 6-9 gauge, \$2.35 base; No. 10 gauge, 6c extra; No. 11 gauge, 12 extra;

No. 12 gauge, 20c extra; No. 13 gauge, 30c extra; No. 14 gauge, 40c extra; No. 15 gauge, 55c extra; No. 16 gauge, 70c extra. Add 6c for coppering and \$2 for tinning.
Extra net per 100 lb.—Spring wire; bright soft drawn, 15c; charcoal (extra quality), \$1.25.

METALS.

Prices per pound to largest buyers: Cents.

Lake copper, Toronto	16.75
Electrolytic copper, Toronto	16.63
Spelter, Toronto	6.10
Lead, Toronto	4.35
Tin, Toronto	50.50
Antimony, Hallet, Toronto	9.50

SHEETS, WIRE AND NAILS.

	Mont'l.	Tor'to.
Sheets, black, No. 28....	\$2 80	\$3 00
Canada plates, ordinary, 52 sheets	2 90	3 00
Canada plates, all bright. 3 70		4 15
"Comet" sheets, No. 28.		4 00
Apollo brand, 28-gauge (American)	4 30	4 20
Copper sheets, tinned, 14 x 60, 14 oz.		30 00
Brass spring sheets, up to 20-gauge		27 00
Plain copper sheets, 14 oz., 14 & 60 inches, per 1,000 lb		29 00
and 60 inches, per 1,000 lb.		30 00

NAILS AND SPIKES.

Standard steel wire nails, base	\$2 40
Cut nails	\$2 55 2 65
Miscellaneous wire nails..	75 per cent.

Pressed spikes, 5/8 diam., 100 lbs.	2 85
--	------

GALVANIZED SHEETS.

B.W. Queen's Fleur-Gordon Gorbals' guage	Head de-Lis	Crown	Best	Best
16-20 .	\$3 70	\$3 35	\$3 60	\$3 70
22-24 .	3 75	3 40	3 65	3 75
26	4 20	3 80	4 05	4 15
28	4 45	4 15	4 25	4 35

FINE STEEL WIRE.

Discount 25 per cent. List of extras. In 100-lb. lots: No. 17, \$5; No. 18, \$5.50; No. 19, \$6; No. 20, \$6.65; No. 21, \$7; No. 22, \$7.30; No. 23, \$7.65; No. 24, \$8; No. 25, \$9; No. 26, \$9.50; No. 27, \$10; No. 28, \$11; No. 29, \$12; No. 30, \$13; No. 31, \$14; No. 32, \$15; No. 33, \$16; No. 34, \$17. Extras net. Tinned wire, Nos. 17-25, \$2; Nos. 26-31, \$4; Nos. 30-34, \$6. Coppered, 75c; oiling, 10c.

MISCELLANEOUS.

	Cents
Putty, 100 lb drums	\$2.70
Red dry lead, 560 lb. casks, per cwt.	6.25
Glue, French medal, per lb	0.10
Glue, 100 flake	0.11
White lead, ground in oil, No. 1 pure, 100 lbs.	8.40
Tarred slaters' paper, per roll... ..	0.95
Motor gasoline, single bbls., gal..	24½
Benzine, per gal.	23½
Pure turpentine	62
Linseed oil, raw	55
Linseed oil, boiled	58
Plaster of Paris, per bbl.	2.10
Plumbers' Oakum, per 100 lbs..	4.50
Pure Manila rope	17

Weekly Market Letter

THERE is no diminution in the consumption of iron and steel, either in this country or the United States. There is, however, less new buying, both of finished material and of pig iron, but this is accounted for by the fact that practically all large buyers are well covered for forward delivery for some time ahead, and have heavy orders on the steel companies' books for spring and summer delivery.

New projects requiring steel, such as is required for building and bridge work continue to loom up every week.

There is little change in prices, the move being upwards if any. Open hearth billets are offered in Pittsburg this week at \$30.00, which is \$10 a ton advance on the price this month last year. There is some quietness and weakness in the pig iron market.

The local representative of the United States Steel Corporation informs Canadian Machinery that the proposed plant at Sandwich is an assured fact; that construction work will start there in the spring, and that they will probably be making steel there in two years.

Mr. Chas. M. Schwab, president of the Bethlehem Steel Co., has denied the report that he is connected with a reported consolidation of a number of independent steel companies of the United States and Canada.

Screws.—Orders for screws, nuts and bolts are coming in freely, with no falling off. This, however, is not a good time of the year for this trade. Stock-taking is only just over, and manufacturers are coming across stocks which require using up. Business should be very brisk in May.

Nails and Wire.—There is a big demand for wire from the trade in gen-

eral, particularly oil annealed and galvanized. Nails are strong, the demand for this product being very consistent. Track fastenings are selling well.

Coke.—Owing to the exceedingly high pitch at which industries are being worked just now, all high grades of coke are scarce, and prices are stiff. Cars are scarce too, which makes it difficult for manufacturers to secure a prompt and good supply. The price of Solvay coke, which is generally used in this part of the Dominion, remains unchanged, though Connellsville coke has taken a jump of fifty cents a ton.

Old Material.—The market in old material is weak and featureless, and prices are not now what they have been for some weeks past. People who bought scrap when prices were high are not anxious to sell, and are holding until a jump occurs again.

"CANADIAN MACHINERY"

A Weekly

¶ With this issue, "Canadian Machinery" becomes a weekly, and every subscriber will receive it four times a month, instead of monthly as in the past—you will get a copy *next week*, not next month.

¶ Subscribers in Ontario and Quebec should get their copies every Thursday. Delivery at more distant points will be later, according to distance from centre of distribution.

¶ Developments and changes in various lines of machinery manufacturing, shop management, shop practice, etc., have been so rapid during the last few years, that a weekly publication has become necessary in order to keep our readers fully informed along these lines. The usual mechanical features for plant superintendents, foremen, draftsmen, etc., will be continued in each weekly issue.

¶ Manufacturers who are interested in effecting economies in their plants, will do well to watch each issue closely for articles pointing the way to savings by suggestions to be obtained from articles on cost systems, efficiency, etc.

¶ Manufacturers having engineering product to dispose of will find in our "Industrial News" dept. many items which will be new to them, and every effort will be made to have this dept. give a complete and reliable record of developments which may mean the purchasing of any class of engineering equipment.

¶ An entirely new feature in "Canadian Machinery" is our market reports on Iron and Steel, Metals, etc. While this department is not as complete in this issue as we would like to have it, those interested will find many items of information. Future issues will show a steady development in this particular feature.

To Advertisers

¶ By changing our journal from a monthly to a weekly publication, we are greatly extending our field of usefulness among our readers as outlined briefly above.

¶ Mechanical men, purchasing agents, and manufacturers will all find news and mechanical articles of vital interest to them in each issue, and by receiving their copy regularly each Thursday, will unconsciously set aside a definite time for looking over the latest issue.

¶ Our weekly issues offer an unprecedented opportunity for advertising to a large list of the best manufacturers, plant superintendents, and purchasing agents in every province of Canada. The frequency of issue, combined with strong appealing copy, will make an impression on buyers that cannot be denied.

¶ Every advertisement in this issue is run under contract and paid for at our regular card rates, and each number will show a steady increase of advertising carried.

¶ A line will bring full particulars, or we will arrange to have our representative see you at an early date.

THE PUBLISHERS

The Necessity of Efficiency in the Office and Foundry*

By Loyal S. Wright **

A foundry may have up-to-date machinery, its capital may be ample, and its product be near perfection, yet there may be no "efficiency." In this address, Mr. Wright outlined some of the essentials of an efficient organization, and emphasized increasing the efficiency of the individual unit, which is trueness plus, by eliminating weakness, sickness and laziness.

PERHAPS business is the only occupation that has not had the true application of science. Some people do not seem to understand what the word science means. In Spencer we find a very simple definition. He says, "Science is organized knowledge, classified facts," therefore, if we get at the basic facts of any subject and correlate them, we have a science. A doctor is not a professional man, however, because he is a scientific man. The difference between profession and science is in practice, so that a business man might be thoroughly scientific, yet if he did not practice this science he would not be a professional man.

The Profession of Business.

There is, and should be, no greater profession than the profession of business. I will give you in a simple way the result of many years of careful research work, and the expenditure of large sums of money in order to reduce business building to a science. That the institution that I have the honor of representing has been successful in doing this is a generally conceded fact.

Three great truths I want you to grasp—and if you truly appreciate them and use them, you will have received a great deal of benefit. The first one is that the science of business is the science of service. The second is, that he who serves best will profit most. The third one is that employers and heads of departments are teachers of their people, consciously or unconsciously, and it is the duty of every employer to realize this and to take means for training the people under them. We do not come assuming that we can run your business better than you can, because we know that your years of experience have made you more or less expert in your particular line, especially in regard to technicalities. We humbly admit you know more about this than we do. What we have to say is suggestive power and methods in order that the execution of your business may be made easier.

Four Departments Involved.

It is well for us to have an understanding of what we mean by the term effi-

ciency. Efficiency is the accomplishment of one's work with the least expenditure of space, time, money, material and energy. I want to confine myself to four departments, namely, producing, executive, financing and selling. I wish, in your imagination, you would draw a circle, and label that circle Business Building. Draw another circle within the other and label that Salesmanship. Draw a third circle, which shall be the inner circle, and label that Service. Thus you see that the blood of business building is salesmanship, but the heart that pumps the blood is service. If you want the heat of profit you must first build the fire of service.

Again, if you will imagine in your mind four great cups. At the top we will call the first cup the Manufacturing Department of business. Over at the right we will name the second cup the Executive department. Over at the left we will call the third cup the Financing Department, and down at the bottom, forming a diamond shape, we will call the fourth cup the Selling Department. The Manufacturing Department, the Executive Department and the Financing Department all pour their product down through the selling department. This does not mean necessarily that the selling department is the most important, but rather, that all four departments are so closely allied and linked together that they form the great composite salesman, and a lack of efficiency in any of them means a general lack of results for the composite salesman, or the firm itself.

Advent of Advertising.

Some years ago competition started in this way. A certain company tried to do a little better than a certain other company that was manufacturing practically the same goods. The other company in turn went the first company one better, and then the first tried to outdo the other by manufacturing their goods a little better. The result of it was that they were perfecting their product to a large extent and thus competition was a benefit, because it made them think. It started their energies to work. Just at this point came that important written salesman called Advertising. Companies commenced to realize that if they made a success of their business the people in

general must know of it, and know something of their products—so they commenced to spend large sums of money through this channel of advertising. Many thousands of dollars have been poured into the gutter through inefficient advertising, and there is still a large flow of money taking the same course. Later, there came the engineer in the business, whose profession it was to systematize and organize and show where waste should be eliminated and efficiency increased. Business, in consequence, has developed and grown, until it has reached this age of specialization, this age of expert artists, and the manufacturing end of the business has finally come to this important conclusion, that they might have a splendid manufacturing plant as far as machinery goes, that they might have ample capital, their product might be nearly perfect, but unless the brains of the individuals through their plant were right, they still would not have efficiency.

Efficiency of the Individual Unit.

The great problem in every country has been to increase the value or efficiency of the individual units, knowing well that if we can successfully increase this, that the composite whole will take care of itself. The efficiency of any individual is measured by the degree of supervision which he requires. This supervision is necessitated because people make mistakes—or commit errors. You have all known this for years, but what you have not known is why people make mistakes, why they commit errors. Here lies the essence of this science.

Loyalty in Business.

That there are positives and negatives in human nature is an acknowledged fact. For instance, in nature we have light and darkness, in human nature we have observation and carelessness. We have imagination and dullness, concentration and scatteration, memory and forgetfulness, reason and unreasonableness, etc. Every normal individual has the faculty to think (this does not mean they all do it, by any means.) They have the power of emotion or feelings, and they have the power of will—choice—and they have the physical side. The positives which I have just mentioned will be found in the know-

*Address delivered before the Philadelphia Foundrymen's Association.

**Eastern Sales Manager, The Sheldon School, New York City.

ing part of the mind, or intellect. In the feeling part of the mind we have powers like faith as the positive, with doubt for the negative: loyalty and disloyalty, honesty and dishonesty, etc. Let me call attention to the faith in business—commercial faith. The man who has this faith in himself, in his business, in his employer, radiates the very spirit of confidence, and confidence is the basis of trade. We cannot make profitable permanent patronage without instilling confidence into the minds of the buying public, and confidence is radiated through that man who has commercial faith.

Let us dwell for a minute on loyalty. There is no greater word in the whole organization of business than loyalty, that spirit in employees which is true-ness plus that makes the employer feel he can absolutely rely upon such persons that he knows they are doing their business and would do no different if they stood in his place. Gentlemen, such a spirit as that brings about that team work which always results in the highest business success. The positives which I have just named in the second division are found in the feelings of the individual.

The Physical Feature.

Let us look at the physical side. We cannot slight this or pass over it lightly, because it is an important part of the commercial organization. Socrates said, "We must be better horses." That a vast amount of business is lost, and that many errors creep into the routine because of physical trouble, is an acknowledged fact. It, therefore, behooves us to study the development of strength by eliminating weakness, of health by eliminating sickness, of industry, by eliminating laziness. Perhaps as much business is lost through this last negative, laziness, as by any other.

There are too many clock watchers. Too many people are like the colored man lying out in the field in the shade of a tree. The planter came along and saw a negro lying under the tree in his field in the afternoon. He looked at him and said, "You negro, what are you doing?" He said, "Boss, I'se the man that was sent here for to hoe this field." "Well, what's the matter? Why ain't you hoeing: are you tired?" He replied, "No sir. I ain't'zackly tired, I was just waiting for the sun to set so that I could quit work." Too many people are not tired, but they are simply waiting for the whistle to blow, that's all, so they can go home.

Development of Initiative.

When we develop the knowing powers of the mind, the result will be increased ability of the intellect. When we de-

velop the feeling part of the mind the result will be increased reliability of the individual. When we develop the physical powers of the body, the result will be increased endurance. Ability, reliability and endurance do not, however, make a successful man. He must develop such powers as initiative by eliminating inertness, decision against indecision, dispatch as against procrastination, perseverance instead of fickleness, and with the development of such positives as these we get his increased action. Gentlemen, the man of positive action is the man who does things, and while I will grant you he may make mistakes, yet, we can overlook a few errors.

Now, if you will go back with me for a moment, you will find that we are evolving a valuable formula, or a yardstick by which you can measure yourself and any employee whom you may have. I said the value of an individual was lessened by the supervision required, necessitated by his errors or mistakes. Every error he makes can be traced directly to some sixty or more of the negatives which exist in his mind and body. Every negative has the germ of the positive power: therefore there are sixty of those. I have shown you briefly what the development of these positives in the knowing, feeling, physical and willing part of the mind means, and the result has been ability, reliability, endurance and action. If you will just take the first letter of these words you will find we have the "Area" of the individual. The extent of this "Area" will determine the ultimate measure of his success. The "Area" of an institution makes up that institution as a whole, so you can see how vastly important it is that you teach each man, and that you train yourself in this great "Area" development.

Salesmanship.

There is a vast difference between the salesman and the order-taker. We believe that the salesman is born and made. We do not believe in the old rusty statement that a man is a "natural born salesman" except so far as he is naturally born. The only natural born salesman I ever saw was the wooden Indian in front of a cigar store, and he sometimes takes more orders than the clerk behind the counter. Granted that the individual has ability, reliability, endurance and action, the next important step for him to master is the science of reading the other fellow and suffice it to say that every salesman, in fact every business man, should be a master of this subject.

In business building and in salesmanship there are four important factors. The first one is the salesman himself;

the second is the customer or the other fellow; the third is the goods or article which he handles, and the fourth is that intangible thing which we call the sale itself. Touching the third factor in business building and salesmanship, namely, the goods, we find there are four important things which we must know. The first is the ability to analyze the subject at hand, or the goods, the article which we are selling; to be able to break the great mass up into units and to ascertain the value of each of those units into a logical arrangement, order or sequence of points; lastly, to be able to express this knowledge in the best possible, clearest way.

A man may know all about his product, and be able to analyze it thoroughly; for instance, I feel quite certain I could take my watch all apart, each of its intricate wheels and parts. I might be able to do this, with a hammer and a screw driver. I am also certain I could not put that watch together again so it would run. In like manner, a man might be able to analyze his goods thoroughly and minutely, and yet not be able to put the result of that analysis in such form that it would appeal to the mind of the customer and persuade him to buy.

This naturally leads us to the question of what takes place in the mind of the customer, because we are all familiar with the fact that the sale is a mental thing and that it takes place in the mind, and that the mind passes through certain distinct mental steps.

How to Effect a Sale.

The first step is favorable attention. There are two kinds of attention—favorable and unfavorable. Unfavorable attention will naturally lead to disgust and repulsion. Favorable attention, if held, will naturally lead to and culminate in the sale. Favorable attention sustained or held, will, of its own accord change into interest, which is intensified attention. If desire is augmented sufficiently it will naturally result in action, or decision to buy. This makes you see that salesmanship, being a mental thing, requires a tremendous lot of magnetism and of enthusiasm.

Let me suggest a definition of salesmanship which you can easily remember. Salesmanship is "The Power to Persuade Plenty of People to Purchase your Product at a Profit." You see how important this last is in this definition. If you leave profit out, you have an order taken, and not a salesman. When the customer's mind passes through these four mental steps and the money and the goods change hands, then we have business-getting, yet a great many concerns mistake this for business-building. For business building there are two more

steps necessary. The first step is confidence, as the result of business done; the second is satisfaction, as the result of service rendered. The best advertisement you can have is the wagging tongue of a satisfied customer.

There is, then, a science of salesmanship, and a science of business-building, but both of these rest heavily upon the science of building the individual.

STANDARD CROSS SECTIONS.

THE committee appointed by the American Society of Mechanical Engineers to go into the question of cross-sections and symbols have presented unanimous findings. They are strongly of opinion that a standard method of showing materials in cross-section should be recognized, and state that there are many advantages in the use of such cross-sections and symbols. It is as easy to draw an adapted design to represent a specific material as to draw any other. It makes mechanical drawings easier to read and understand, and diminishes the danger of interpreting their meaning wrongly.

They do not believe it wise to complicate the matter by adopting too

commonly used materials, and that these should be of such a character as to permit of subdivision, if found desirable. To this end, they propose the use of standard cross-sections to represent nineteen materials as shown in Fig. 1, —cast iron, wrought iron, east steel, wrought steel, babbit (or white metal),

to specify a material other than those mentioned above, or some particular kind of material which the above generic names would not clearly indicate. To cover this contingency, they recommend writing the name of such material on the section and cross-hatching the section, as shown in Fig. 1 under the

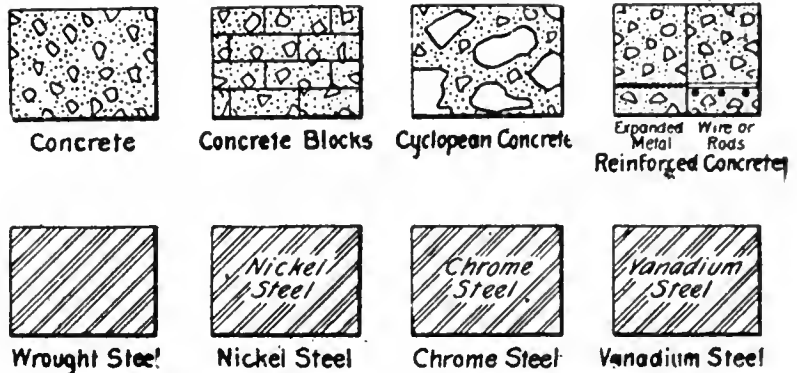

FIG. 2. TYPICAL SUBDIVISIONS.

copper (brass or composition), aluminium, rubber (vulcanite or insulation), glass, wood, water, puddle, concrete, brick, rubble, ashlar, rock, earth and sand. To facilitate the drawing of cross-sections, the committee have used

title "Other Materials." They recommend, also, that subdivisions of any of the materials shown generically on Fig. 1, should be made by taking one of these standard cross-sections as a basis and making minor changes, but maintaining the general characteristics; or by writing on the standard section the name of the material. To illustrate, the committee have subdivided concrete into concrete blocks, cyclopean-concrete and re-inforced concrete, as shown in Fig. 2; also wrought steel into nickel, chrome and vanadium steels.

It is urged that the standard cross-sections should be printed in a suitable form for hanging on walls of drafting rooms of engineers, architects and educational institutions, so as to encourage their universal use.

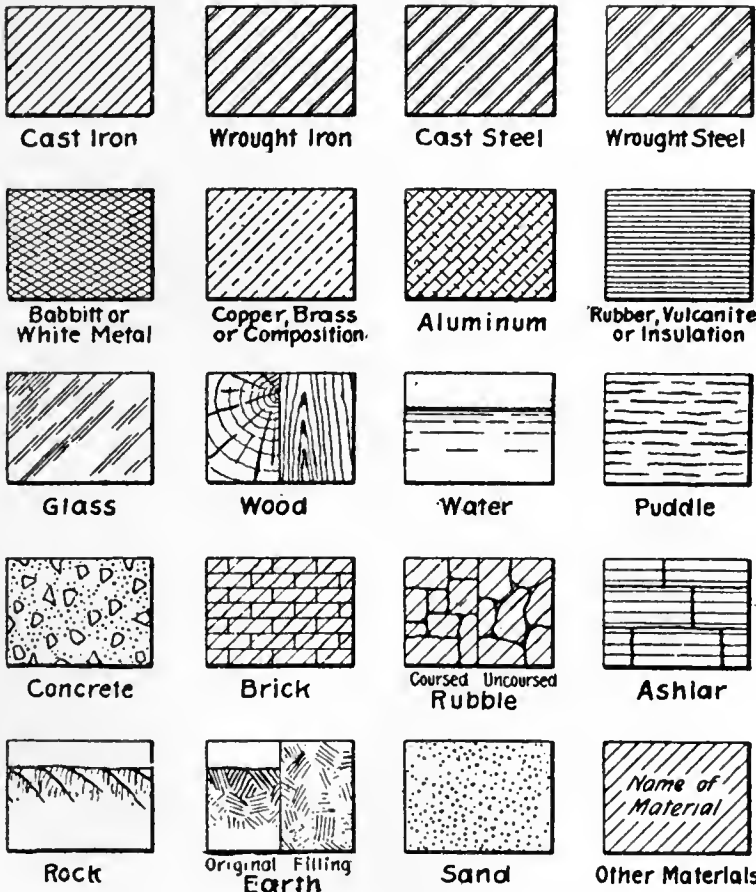

FIG. 1. RECOMMENDED STANDARD CROSS SECTIONS.

many standard cross-sections or symbols. It would be best, they consider, to have standard cross-sections for the most

the same thickness for all lines made with the drawing pen.

On some drawings it may be desired

CURES FOR MISFIT EMPLOYMENT.

By H. F. J. Porter.*

DON'T expect to find in strikes the greatest industrial waste; it will be found in the wrong employment of men. Out of ten men probably only one fills the job that he ought to be filling; and out of ten jobs probably only one is filled by the man who ought to be engaged for it.

The Testimony of Common Experience.

Of all the statements made before the last Conservation Congress at Indianapolis, this one left perhaps the strongest single impression upon the thousands of delegates who had gathered to consider the saving of vital resources. Every one felt that the plain, unsupported statement needed no statistical evidence to give it weight. Common ex-

*Secretary, Efficient Society.

perience testified to its substantial correctness. Of course, there are jobs that are not fit for any man. They are not careers—they are seething infernos. Again, there are men who are as certainly not fit for any job. Such jobs and such men are huge unsolved public problems in themselves, but an even greater problem confronts society, because, in nine cases out of ten, the fit man and the fit job do not meet.

Vocational Guidance.

To grapple successfully with the delicate and perplexing task of the assignment of work will require increased effort along several lines. Vocational guidance is perhaps the most important. Genuine expert advice to young or prospective wage-earners as to the work for which they are fitted is a social need of the greatest value. In response to recognized need, a science is developing for the discernment of latent talent, and the men engaged in this work will have an increasing influence upon educational methods. Indeed, the time is not far off when vocational guidance will begin with the kindergarten, and when, as fast as a talent is discovered, it will govern the later emphasis in the education of the student. This will mean a gradual and rational induction of all pupils into special studies so that they will pass almost imperceptibly from general theory into the actual conduct of their life work.

At best, however, vocational guidance secures only approximate judgments. There are many jobs within a vocation, and there are great numbers of men in each calling. A much closer articulation between worker and work is needed than a mere tactful steering of a talent into the kind of labor for which it is designed. Work within a vocation has infinite variations, and to secure every time, the man who most nearly fits the requirements, demands from the employer or his agent a special discernment. The science of hiring, of which we hear relatively little, is needed to supplement the science of vocational guidance.

The Science of Hiring.

Only recently the Efficiency Society, which includes among its thousand members many of the largest employers of the country, emphasized this new subject of scientific hiring at a special conference held in New York. At this meeting the various standards for appraising men were briefly considered. During the coming year the society will conduct careful investigations concerning this important supplement to vocational guidance.

A wider interest in these two complementary subjects, the science of guiding the worker and the science of selecting the employee, will go far toward

eliminating the economic wastes from misfit employment. There are other remedies to be applied to this problem, however, which are of an equally fundamental nature. Sometimes a deserving man doesn't find the right job because he is miles away. To remedy this situation there must be a freer movement of labor and better means for spreading reliable information about the conditions of work in various localities. Little short of Federal Governmental action or a national co-operation between State and municipal employment bureaus can provide such facilities.

Complete Industrial Organization Necessary.

Sometimes a man doesn't find the right job because he cannot afford to wait for it. Seasonal fluctuation in industry frequently throws capable people out of employment and forces them into work for which they are less fitted, but in which they are often by economic necessity compelled to stay. The cure for this is a more complete industrial organization. A thoroughly organized industry, by registering all of its members, by insuring them against temporary unemployment through funds to which employer and employee contribute equally, and by scheduling work so nearly continuous as possible, will enable workers to choose their careers and to remain with them in increasing efficiency and contentment during their productive years.

GRAIN ELEVATORS FOR THE WEST.

THE annual report of the Federal Grain Commission, issued on Feb. 3, strongly recommends Government action towards establishing a system of Government internal grain elevators in the West, with transfer elevators on the Pacific and Hudson Bay, so that there will be adequate facilities for handling future grain crops to the best advantage, on the completion of the Hudson Bay Railway and the Panama Canal. The Commissioners suggest that they be given authority to investigate and report on the most suitable locations for these elevators. They also recommend sample wheat markets at Winnipeg and Fort William, and the establishment at Winnipeg of a laboratory for testing the milling and baking qualities of Canadian grain.

The report notes that there are now in the West 2,225 elevators, with a total capacity of 67,000,000 bushels. The capacity of the terminal elevators at Fort William and Port Arthur is given at 27,820,000 bushels, as compared with 25,700,000 in 1911. During 1912 preparations were made for additional stor-

age accommodation to the extent of 12,120,00 bushels.

D.C. SUB-STATION DESIGN.

NOTES on Direct-current Sub-station Design and the Plant Installed," was the subject of a paper read by Mr. H. D. Phelps before the Newcastle Students' Section of the Institution of Electrical Engineers. The author outlined the principal requirements of the site, buildings, etc., and discussed the lay-out of plant therein. He described the principal features of induction motor generators, motor converters, rotary converters, and synchronous motor generators, and discussed their relative merits for sub-station equipment. Induction motor generators, on account of their low efficiency and poor power factor, especially at light loads, might be left out of consideration, as also might synchronous motor generators, on account of their high cost. In comparing motor converters and rotary converters, he gave preference to the latter for 25-cycle traction sub-stations, but for higher frequencies he considered the motor converter more suitable and less liable to flash over.

MECHANICAL STOKING OF LOCOMOTIVES.

WITH the rapid increase in size and power of railway locomotives during recent years, the problem of mechanical stoking has engaged the attention of locomotive engineers, especially in the United States, and several more or less satisfactory contrivances have been evolved. Tests made in South Africa have demonstrated the usefulness of such an appliance, and, as it becomes necessary to provide still larger engines, there is no doubt that a suitable mechanical stoker will become more and more a necessity. That now being experimented with on these railways (reports Mr. Hoy) is an advance on any previous type tried, but further improvements are necessary before it can be said to be of practical value. When oil fuel is available at a cost which will compare with coal, locomotive work will be much simplified, and it is hoped that oil will yet be found in payable quantities in Africa south of the equator.

Some men control their business; others are controlled by it. Some men are more self-sacrificing than others, some are more industrious, but when all is said and done, the only real way to get a man to work well is to offer him something worth working for.

The Coal Resources of the Dominion an Empire Asset

In these days when so much attention is being directed to the possibilities of oil fuel in its varied applications, it may not be amiss to point out the prominent place that coal mining fills in Canada's industrial development, and to have brought home to us some facts and figures concerning same.

OUTSIDE the United Kingdom the nearest Imperial source from which fuel can be secured is Canada, and the nearest portion of it in which extensive coalfields exist is Nova Scotia. All the discovered coal measures of the province are adjacent to the coast, and those who are acquainted with the mineral resources describe the supply as inexhaustible. Twenty years ago, Nova Scotia's annual production of coal was about 1,000,000 tons, a figure which five years later had increased by 50 per cent., and within a decade by 100 per cent. In 1911 the output aggregated 6,994,000 tons, valued

list of producers are the Nova Scotia Steel and Coal Co., the other big concerns being the Aegidia Coal Co., the Inverness Railway and Coal Co., and the Maritime Coal Co. The Dominion Coal Co. produce a steam coal of good quality and do a large bunkering business, besides shipping coal to such far-distant markets as Mexico, South Africa, and the West Indies.

Eastern Coal Deposits.

The tendency in Nova Scotia is towards the extinction of the small coal-owner. Two decades ago the number of

difficulties are somewhat increased owing to the necessity for carrying the workings under the Gulf of St. Lawrence. Inverness coal is, for the most part, of fairly good quality, but the lack of adequate and ice-free harbors involves long haulage of the coal—in some cases all the year round—to the Straits of Canso.

Nova Scotia's richest store of coal is contained in the Sydney field, in which it is estimated that there lie some 9,000,000,000 tons. The area extends for about 32 miles along the coast, runs about 8 miles inland, and can, it is believed, be penetrated for miles under the sea. The measures are dry and free from gas, while the easy incline at which, for the most part, the coal lies, added to the contiguity of good harbors, have combined to create an industry of important dimensions. During 1911 the Dominion Coal Company alone shipped 1,450,000 tons to St. Lawrence ports, they having a fleet of steamers which carry a large proportion of the total production during the open season of navigation.

Western Coal Fields.

Taking the Dominion as a whole, the total annual coal production is in the neighborhood of 13,000,000 tons, this figure comprising sales and shipments, colliery consumption and the fuel used for making coke. Crossing the Dominion towards the Pacific coast there are coal measures of minor importance in New Brunswick, but no seams of any magnitude are found until we reach Manitoba. The coal-bearing area of this province extends for about 15,000 square miles; while the neighboring Province of Alberta contains something like 85,000,000,000 tons—lignite, bituminous and anthracite. Little of this could be of much service to the Mother Country, in view of the long rail haul to the coast, but it is, nevertheless, interesting to learn that in the opinion of an eminent authority on the mineral resources of Canada, the richness of the Alberta measures renders it highly probable that in course of time the province will become one of the greatest coal-mining centres, not only in the British Empire, but in the world.

In the year 1910, the daily output of the Alberta mines, of which there are about 150, large and small, in operation, was about 18,000 tons; in other words, the annual production was nearly 3,000,000 tons, an increase of 59 per cent.,



COAL HEWER AT WORK IN A CALE BRETON MINE.

at about \$14,050,000, the increase in production as compared with 1910 being 600,000 tons. The industry gives employment to some 12,000 persons, whose annual wages bill amounts to \$7,500,000.

The largest colliery undertaking in the province is the Dominion Coal Co., who have seventeen collieries in operation and three more which will, before long, be adding their quota to the Company's aggregate output. They raise at present 4,000,000 tons annually. Second in the

companies engaged in the industry was twenty; to-day there are under a dozen, and only six of these are operating on a really large scale. The coal deposits may be divided into four divisions. There is, first of all, the Cumberland coalfield, situated on the Bay of Fundy, where, however, the cost of mining is rather high owing to the disturbed conditions of the coal measures. The same remarks apply to the Pieton and Inverness districts, and in the case of the latter, the

compared with the figures for 1907. The total production of the Dominion in 1910 was almost equally divided between the eastern and western coalfields, and Alberta contributes about 22 per cent. of

permitted of the domestic price being maintained at a figure which enables Californian fuel-oil exporters to compete for the fuel requirements of those railways and steamships which burn

that the market is growing faster than the collieries are being developed, and that the present price of coal is likely to be maintained, a consoling thought to the mineowners, if not to the consumer."

Coal in British Columbia.

In spite of the operations of the various colliery companies the coal measures of the province have as yet hardly been scratched. Many fields of proved value, though they have been partly developed, have not contributed a ton of coal to the market, largely because the demand is at present fully supplied. Lack of transportation facilities is another obstacle, altho this can, and doubtless soon will, be remedied. Hundreds of millions of tons of coal are lying ready for the hewer, and a very considerable proportion of this hidden wealth is situated adjacent to the Pacific Coast, both on the mainland and on Vancouver Island. In the valley of the Skeena river there exist extensive beds of anthracite, the output from which could be brought to tidewater at comparatively



NOVA SCOTIA STEEL & COAL CO. COAL AND ORE PIERS AT NORTH SYDNEY, C.B.

the whole, as against 5 per cent. ten years previously.

In British Columbia a coal of better quality is produced, there being several rich seams of excellent anthracite. In 1910, the coal output of British Columbia reached a total of 2,800,046 tons, of the value of \$9,800,161, which figures constitute the highest ever recorded in the history of coal-mining in the province. The greater proportion of the output—about 79.3 per cent., in fact—came from the collieries owned by three companies—the Canadian Collieries (Dunsmuir), Ltd.; the Western Fuel Co., on Vancouver Island; and the Crow's Nest Pass Coal Co., in the East Kootenay or Rocky Mountain district, which, by the way, exports something like 80 per cent. of its production to the United States.

Mr. W. F. Robertson, the mineralogist of the Province, states in the annual report on the mining industry of British Columbia that the demand for export coal, especially on the seaboard, has been so constant and the price obtainable so satisfactory to the shippers that it has

liquid fuel. "The maintenance of the present high price of coal on the seaboard in face of the direct competition of fuel-oil both in British Columbia and

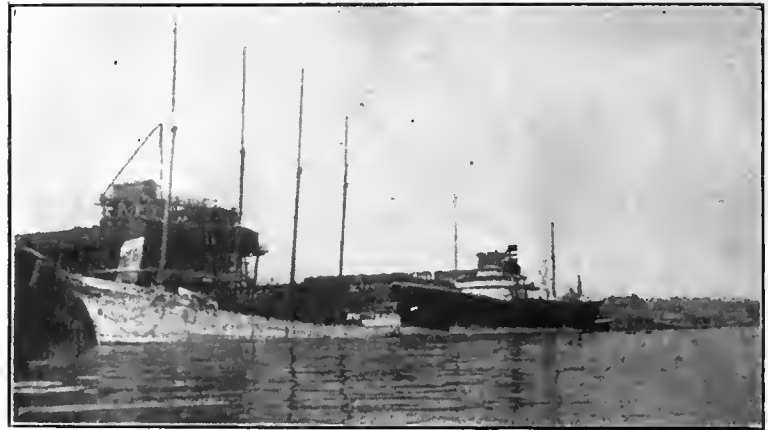

SHIPPING BRITISH COLUMBIA COAL AT NANAIMO.

Pacific Coast of the United States, and the fact that the British Columbia collieries have greatly increased their output, would," he says, "seem to indicate

moderate cost. The coal industry of the Dominion is making steady progress, although the report on mineral production issued by the Department of Mines, show a slight decline in 1911.

Bunkering Facilities at St. John, N.B.

The bunkering facilities provided by the port of St. John, New Brunswick, may prove of interest, seeing that geographically it is very favorably situated for vessels engaged in the North Atlantic trade. No other Canadian Atlantic port can compete with St. John in point of cheapness, for there is no reason why coal from the adjacent Queen's County field should not be brought down the river for at least seven months in the year at a cost of from 16 to 20 cents per ton, as against a dollar a ton in the case of the Cape Breton coal generally used in the port. Moreover, the price of the latter is enhanced by unnecessary hand-



LOADING CAPE BRETON COAL.

ling, which also means breakage. Queen's County coal has been employed with satisfactory results by at least one British steamship company engaged in the Canadian trade.

From the foregoing it will be noted that we have not only the resources for more than immediate future contingencies, but the port facilities and ready markets in addition.



AIR-OPERATED HYDRAULIC DROP PIT JACK.

By M. J. Hayes.

THE operation of removing the driving wheels from locomotives is accomplished in a great many different ways in the various railroad plants of the country. In the majority of shops a traveling crane is used, which lifts the engine off the wheels and carries it to another pit, the wheels being then carried away to the wheel lathe. In others, an electric hoist is used which raises the engine up, the wheels being then rolled out and the engine let down again on blocks. In some shops with limited facilities jacks are still used, and the engine is jacked up first at one end, and then at the other, being blocked securely at each end in turn, until finally it is high enough to allow the wheels to be rolled out. This is a laborious and dangerous operation and takes considerable time and labor to accomplish.

The method in use, where the number of the engines handled does not justify the installation of a traveling crane, is the drop pit method. In such a shop, the engines are moved over a pit with removable rails, and a jack, mounted on a

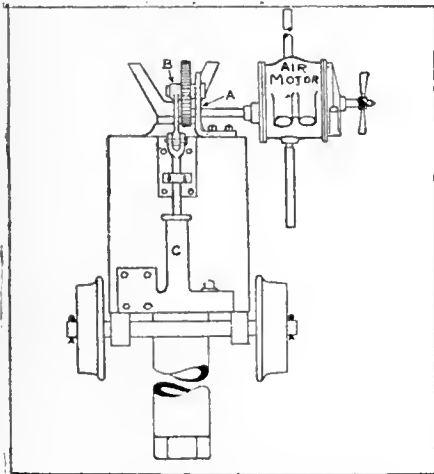

FIG. 1. AIR OPERATED HYDRAULIC DROP PIT JACK.

carriage, runs along the pit bottom. After removing the pedestal binders and taking the weight of the engine with jacks placed under the buffer beam and end rails, the pit jack is run up and takes

the weight of the pair of wheels off the rails which are then removed and the wheels lowered into the pit. The carriage and wheels are then moved clear of the engine, and the wheels jacked up level with the floor and run off to the wheel lathe or wheel press. The rails are then replaced, the locomotive is moved forward to bring the next pair of wheels over the jack and the operation repeated. In replacing the wheels, the operation is of course reversed.

Different styles of jacks are used in such pits; some use the screw jack, which is very slow, while others use air jacks

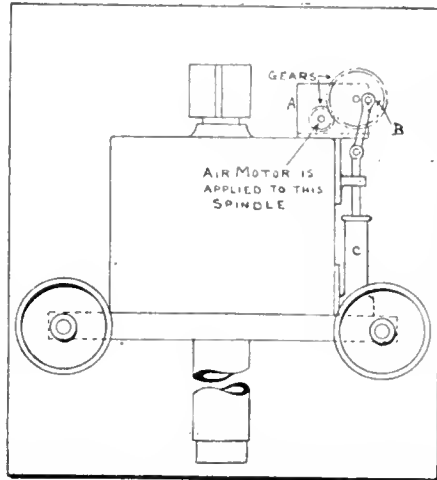

FIG. 2. AIR OPERATED HYDRAULIC DROP PIT JACK.

which are fast, but not always safe. The majority prefer the hydraulic jack, which, although not so fast as the air jack, is a great deal more dependable.

The accompanying sketches show how a hydraulic pit jack was changed at the shops of the T. H. & B. Rly. at Hamilton, Ont., and made nearly as fast as an air jack, while still retaining the safety of the hydraulic. Originally it took two men on the end of a 4-foot lever to raise a heavy pair of driving wheels into position under an engine, and took just five times as long as it now takes a boy and a "Little Giant" air motor to do the same thing. As will be seen by the sketches, after taking off the hand lever, two gears with a ratio of four to one were fastened to the bracket (A), which was bolted to the top of the reservoir. In the larger of the two gears was inserted a crank pin (B), having a 2-inch throw. This was coupled up by a short connecting rod to the plunger of the pump. The small gear was keyed to a shaft, which extended through the bracket and had one end turned to a No. 3 standard Morse taper.

All that it is necessary to do now, when the wheels are to be raised, is to apply the air motor and turn on the air, the wheels being lifted into place with a great saving of time and labor.

RAILROAD CAR EQUIPPED WITH EDISON CELLS.

THE Electrician gives some particulars of a car which has been placed in service on the Chicago Great Western Railway for use in connection with the local passenger and express traffic. The car is equipped with 220 Edison cells for power purposes and 10 for lighting use. These batteries are placed under the car in two compartments, strongly reinforced and riveted to the underframe. The batteries are of the special railway type, and have 3 in. of electrolyte over the plates. The car is equipped with four 20 horse-power, 75-ampere, 200-volt, series-wound motors running at 720 revolutions per minute. Two of these are placed on each truck, one on each axle, and one wheel on each axle is driven by a gear fastened to the inside of the wheel hub, the ratio of reduction being 3.5:1. There are two series-parallel controllers, one on each end of the car, with four series and three parallel positions. All power wires are carried in conduit securely fastened to the underframe.

In all its trial runs the car showed very satisfactory running qualities. Most of its trips were made between Jersey City and Silver Lake, N.J., a round trip of about 20 miles. A maximum speed of 35.6 miles per hour on level track and 29.6 miles per hour on a 2 per cent. gradient was attained with an energy consumption reported to be 30.4 watt-hours per ton-mile in the former case, and 46.3 watt-hours per ton-mile in the latter. The car, including the battery, weighs 29.5 tons.



DRAWING OFFICE EFFICIENCY AND ECONOMY.

By A. M. Rochester.

THERE has been considerable discussion in the technical press lately on the above subject, one point considered being whether or not speed of execution has a large bearing on the general question of individual efficiency. The writer was for many years employed as a draftsman and has worked in a good many different shops and offices, so that his opinions on the subject are at least not those of an amateur.

Designers.

As the efficiency of the individual is largely and primarily a question of the right man in the right place, there are certain fundamentals which a draftsman, to be successful, must possess. He should first of all be a man of constructive habits of thought and possess an active imagination, so that he is able to see "in his mind's eye" the outline of the machine or other structure he is design-

ing. He should also have an analytical temperament to be able to systematically and logically consider each new point as it is presented and to recognize the good and reject the bad features of each. All this presupposes and should supplement a thorough and exact knowledge of the general principles of design and a full acquaintance with the state of development of the subject in hand and of present practice with regard thereto.

The above remarks refer more particularly to designers, or men doing original work, and it is usually a matter of wise economy to pay such men a high wage in view of the importance of the results expected. The matter of speed of execution of the work is usually secondary to the importance of having the work done thoroughly and satisfactorily. To try to distinguish between two men by the test of mere speed will give a very inconclusive result, since one man may be slow and methodical, never drawing a line until he is certain it will not have to be afterwards erased, while another man may draw a device a dozen times and rub it out time after time until he is satisfied with it. Both ultimately obtain the same result. Now if the slow man works three months on the job and the quick man works one month, but the slow man's design is acceptable while the other's is not, it is clear that the slow man's work is the more valuable, even if it cost three times as much as the other. It will usually pay to allow a designer all the time he desires to study a problem, provided the end sought is accomplished. It is not wise to hurry him unduly.

Detailers and Tracers.

When it comes to detailers and tracers, however, the question of speed in relation to economical production is of more importance. As the work of these men is of a more or less mechanical nature, not involving much original thought, it is comparatively easy to distinguish between different individuals on the basis of output, and to grade their pay accordingly. If two men at this class of work are on even terms as regards neatness of execution, it nearly always follows that the speedier one is the more efficient, and the element of speed should be a basis for determining which man's work is of the more value.

Time Saving Appliances.

The writer was lately working in the drafting room of a firm which has given the question of efficiency in every department most painstaking attention and has been modernizing its methods with that end in view. This firm has made quite an investment in time saving appliances for the drafting department with a marked increase in the efficiency of the workers.

There are many things draftsmen occasionally need in their work and which few of them possess, as they usually consider that they will not get their money's worth of use out of them. Among these may be mentioned a beam compass, an 18-inch triangle, a pair of proportional dividers, etc. In the shop just mentioned all these are furnished for the general use of the draftsmen by the company, who believe that such appliances will receive sufficient use by a staff of twenty-five men to justify their purchase. In addition to the above, the company have installed a pencil sharpening machine, a section liner, a set of scales for odd proportions, such as 3 to 2, and a set of "Payzant" lettering pens for block letters and border lines. Other devices are being added from time to time. A great labor-saver to be found here is a motor-driven erasing machine, consisting of an ordinary circular eraser mounted on a flexible shaft joined up to a small electric motor. The latter can be coupled up to the nearest lamp socket, and by its use remarkable results are accomplished. In the drafting room in question all those appliances regularly supplied to the draftsmen by the employer are of the best type. Thus the drawing boards are equipped with parallel attachments, dispensing with the usual Tee squares; the tracers' inkwells are of the "Alteneder" pen-filling type. In short, everything in the drawing office has been selected with a view to obtaining the most efficient results.

There are doubtless many firms who could follow the above example with advantage.



KNOTS AND SLINGS.

By F. R. Parsons.

AMONGST the duties of engineers, power-house attendants, mechanics and erectors generally is that of handling awkward-shaped and sometimes cumbersome masses of metal, engines and engine parts, machines, girders, joists, gearing, shafting, etc. There are innumerable little lessons to be picked up in this direction, which, when learnt,

are invaluable as time savers and aids to safety. Many lives have been needlessly sacrificed through the snapping of a twisted link in a chain, a faulty knot in a rope, a rotten sling, eye bolt or shackle, or a job slipping out of its tackle when hoisted. Many of these accidents might have been avoided had those in charge known the right and safe way.

Slings and methods of slinging, the right and the wrong way of tying knots, hitches and bindings, are worth serious attention. Simple knots, simple as they may be in themselves, form the very foundation of that knowledge which any erector finds indispensable. Fig. 1 shows the right and wrong way of tying two ropes together, or the ends of one rope in order to make a sling. In the right way no amount of tension will cause the ends to slip, but if wrongly tied, with ends (A) (A) as shown, these will have a tendency to withdraw themselves directly the pull is applied. A variation of this knot is also shown in Fig. 2. A scaffold knot, or as it is sometimes termed, two half hitches, is

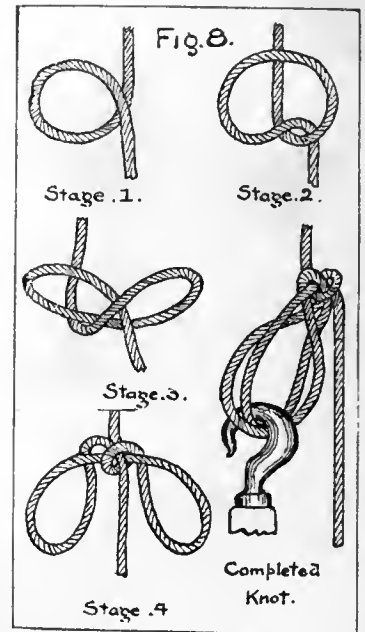

KNOTS AND SLINGS.

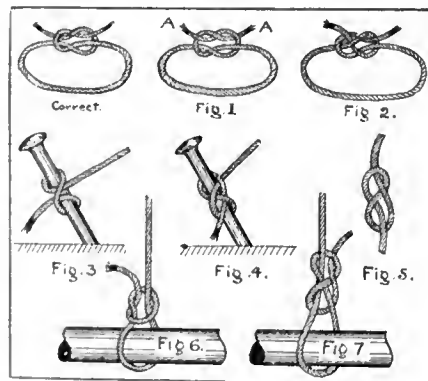

KNOTS AND SLINGS.

another simple tie over which frequent mistakes are made. This is a knot useful for various purposes, not the least of which is securing the ends of guy ropes to stakes driven into the ground when erecting high derricks. This application which is the correct method of tying it, is shown in Fig. 3. Fig. 4 is another knot much in favour in some quarters, used for the same purpose, and really an adaptation of the simple twist or figure eight knot in Fig. 5. If you make a slip in the end of a rope like Fig. 6, you are courting trouble; see that the loose end is tied like Fig. 7.

To make a bight in the middle of a rope on which to hang lifting tackle.—If the two ends are engaged and there is some loose rope in the middle, proceed

a collar or a lathe carrier affixed to the top end of the shaft; but an effective and secure way of doing it without the use of these is shown in Fig. 10.

The Rope Sling.

A sling is a rope with the ends spliced together. It serves a variety of purposes and can be readily adapted to many requirements that a rope falls short of, but one can easily go wrong in using it, simple as it appears, for there are several wrong methods to the one right one. Fig. 11 illustrates a wrong method; the right method being to cross the sling as in Fig. 12. Here again there is a liability to go astray when attaching the hook for lifting. This should never be put through the loops in the direction (A) to (B), but from (C) to (D), and should this appear a trivial detail, try it and note the difference. A basket hitch is shown in Fig. 13, and its application in Fig. 15, attached for lifting (A) a cast iron column. When one sling is short join two together in the manner indicated by Fig. 14.

In splicing derrick poles, a good plan is to dovetail the poles to be joined, as in Fig. 16, whipping the joint with rope, and to ensure neatness with strength,

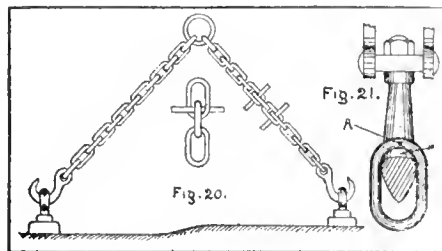

KNOTS AND SLINGS.

it should be done as shown. In starting the bind, leave sufficient of the first end of the rope so that it can be pulled tight when wound, and when finishing interpose a stick or hammer shaft between the pole and the last half dozen coils, so that when the latter number is completed, the stick can be withdrawn, and the rope end pushed through. Next, tightly pull up each of these coils singly, finishing off with a stout pull on the rope end. If this is done carefully, the coils being hammered down with a wooden mallet, as you proceed, and the ends pulled tight and afterwards cut off, you will have an excellent splice.

It may be of interest to describe the methods employed when a rope end requires to be bound around a "thimble" and afterwards whipped, as in Fig. 17. This, if done by hand alone, does not result in a satisfactory job, owing to the degree of tightness required. Therefore, it is best to have recourse to the method adopted by many old sailors. They use what is termed a "serving

board," as illustrated in Fig. 18. It is made throughout of hard wood, finished with a round smooth handle, and longitudinally grooved to fit the diameter of the rope. The method of using it is shown in Fig. 19. The cord is twisted once round the instrument as shown, the loose end round the handle held lightly, and the board turned in the direction of the arrow. By this means, the whipping can be done quickly, and as tightly as the strength of the cord will allow.

Sling Chains.

If, when lifting with coupled sling chains, you find one end of the sling too long owing to the points of attachment being out of level, don't on any account knot the sling—it is a dangerous practice. Adopt the course shown in Fig. 20. Bolts or pieces of round iron interposed between the links will allow to a nicety for a limited amount of variation, and the work may be slung level without endangering the safety of the links.

Another danger with sling chains is that of using a link too small for the body of the lifting hook—one which does not bear properly but forms an arch. This danger is illustrated in Fig. 21, the tendency of the link being to fracture at (A) when strained.

Care Of Ropes and Slings.

Just a few concluding remarks on the care of ropes and slings. Don't allow ropes or slings to get alternately wet and dry, this rots the fibres. Don't keep ropes in a damp place. Don't permit ropes to get more greasy than can be avoided; remember that a knot always grips better in a dry rope than a greasy one. Don't put knotted ropes away in the store, always untie them and give them a few blows on the floor in order to straighten out the fibres. Don't allow the ends to become frayed; keep them whipped. Don't fail to protect a rope sling against contact with sharp edges or corner when lifting; interpose old sacking, waste or board. Don't fail to run your eye down a rope always before using. Don't under any consideration, permit a twist or a knot in a chain sling. Don't hitch a chain sling over a girder or joist in such a manner that a part of a link lying horizontally is overhanging the edge, and so has to bear the whole strain of the load. Don't fail to have your chain slings periodically annealed; the links become crystalized through repeated strains in one direction. Finally, don't forget that you can always have your slings tested by competent people at a nominal charge.—From "The Machine Tool Engineer."

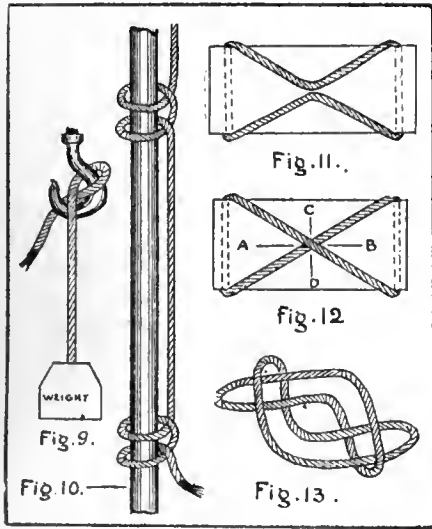

KNOTS AND SLINGS.

as shown in the first stage of Fig. 8. The second stage shows the single loop given an upward twist, thus forming a double loop—half on each side of the vertical portion of rope. Another twist in the same direction, keeping the loops equi-sided, brings the knot to the third stage. Take the two loops, fold them backwards (from you) and bring them together, and you are then ready to hitch in the hook of the lifting tackle. If this is done correctly you will have a bight which will never slip. It is quickly made and as quickly undone—which cannot be said of the ordinary doubled loop knot when strained tightly through lifting. In all knots of this description the primary object to keep in view is that each tightening curve or twist of the rope bears on the one which has the most tendency to slip. This is best exemplified by a study of the old and extremely simple loop seen in Fig. 9.

To lift a shaft into perpendicular position.—Some do this by lifting from

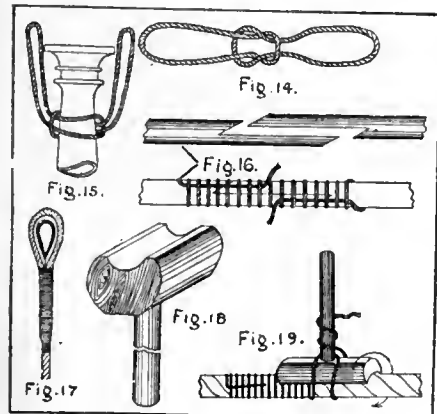

KNOTS AND SLINGS.

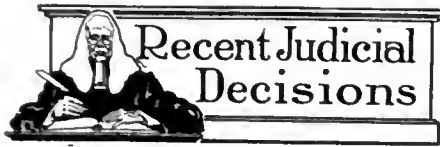

Toronto, Ont.—Robt. S. Hunt was recently awarded \$2,500 damages for the loss of a foot, sustained while taking down easings from a cement roof when the scaffold broke. John E. Webb Co., were the defendants.

Dundas, Ont.—A jury has awarded \$1,650 damages against Jones Bros. Co., Ltd., to a widow, whose husband was killed in defendant's factory by being struck with a piece of wood that had come in contact with the belt or driving shaft of the wood-turning machinery. "Do I understand you don't accept the theory put forward that the deceased was holding the belt on by a piece of wood?" asked the judge. "We do not accept that theory." was the foreman's reply.

The defendant's lawyer moved for a non-suit, on the ground that the judge should have held that it was established that the accident was due to the negligence of the deceased, or to his disobedience.

Toronto, Ont.—The Kent Co., Ltd., Montreal, were sued recently by a stationary engineer in charge of refrigerating machinery, for damages resulting from the blowing out of a joint, which allowed ammonia to escape. Judgment was given in favor of the plaintiff, and damages were assessed at \$1,000 and costs.

Toronto, Ont.—Judgment for \$1,000 in favor of Mrs. Hattie Peacock and her two little daughters against Wells & Gray, was entered by consent at Osgoode Hall a few days ago, having been ratified by Mr. Justice Latchford. Mrs. Peacock sued for \$5,000 damages for the death of her husband, Wm. Peacock, who was killed by the fall of a derrick, on September 13, 1912. He was foreman of a derrick crew, and had been employed by the defendants for nearly five years. His employers alleged that if the derrick was faulty Peacock should have known of it and remedied it. Of the judgment, \$150 goes in costs. The balance will be paid into court and will be paid out in instalments for the maintenance of the children.

GRAIN SHIPMENTS AHEAD OF LAST YEAR.

The Canadian Pacific Railway has given out the official returns of all wheat marketed over their lines from September 30, 1912, to January 25, 1913. An increase of over 30 per cent. over

last year in the gross amount of wheat marketed is shown, and an increase of nearly one hundred per cent. in other grains. This season, 81,747,000 bushels of wheat and 28,126,000 bushels of other grains were marketed, as compared with 61,740,000, and 14,388,000, respectively, last year. This season's shipments consisted of 41,877 cars of wheat and 14,105 cars of other grains to the elevators and 11,147 cars of wheat and 3,948 of other grains shipped direct. The totals show 71,077 cars of grain this year and 48,379 last.

WASTE OF NATURAL GAS IN CANADA.

By W. J. D.

MUCH has been written about the saving effected by using natural gas in gas engines to generate power, instead of burning the gas under boilers to generate power from steam. Experiment has shown that the amount of gas required per hour, for the development of one horsepower, varies from 9 cu. ft., with the highest type of large internal combustion engine, to 130 cu. ft. with the ordinary steam engine. In other words, the efficiency of the gas is over fourteen times as great when used in gas engines as when used for generating steam under boilers.

It has also been suggested, in other countries, that provision be made for preventing the use of natural gas for such purposes as lime and brick burning, etc., in order to conserve this ideal and economic fuel for domestic and other less wasteful industrial purposes, for which, owing to its nature, it is especially useful.

Reckless Waste in Canada.

We, in Canada, need not at present consider the above refinements in the use of natural gas. Such a course, particularly in Western Canada, would seem like trying to stop a leak in the bung before "heading" the barrel.

Natural gas rights in the Provinces of Alberta, Saskatchewan, Manitoba and Northwest Territories are disposed of under Dominion laws. These laws make no provision for preventing the waste of natural gas, and the consequence is that considerable waste occurs. The importance of natural gas in Alberta may be realized when it is considered that a company is now piping it from Bow Island to Calgary, a distance of 175 miles. In addition to supplying Calgary, the company has branch lines to Lethbridge, MacLeod, Granum, Nanton, Claresholm, Brooks and Okotoks.

The province of Ontario has reduced the waste of natural gas to a minimum by causing all abandoned wells to be

plugged and by levying a tax of two cents per thousand feet, with a rebate of 90 per cent. when the gas is used.

FORT WILLIAM.

FORT William lays claim to having seenred during 1912 more manufacturing industries employing the greatest number of men than any other city in the Dominion of Canada. The particulars are as follows:—

Canadian C. & F. Co.	\$1,500,000	1,600
Fort William Starch..	500,000	200
National Tube	400,000	150
McKellar Bedding ...	100,000	60
Great West Wire	100,000	60
Superior Brick	200,000	100
Mt. McKay Pressed..	100,000	50
Maritime Nail	700,000	250
Can. Steel Foundries.	250,000	250

Total cost of plants \$3,850,000
 Total number of men employed 2,720

ONTARIO NATIONAL BRICK CO.

CONSTRUCTION of the works and plant of the new Ontario National Brick Co. is proceeding apace. Foundations for two of the three big kilns have already been completed, and the masonry erected a couple of feet above ground level. The same amount of work has been done on the machinery building, which is now ready for the steel. This steel is already on the way from Montreal, and it is now anticipated that the entire plant will be ready several days before the time specified.

Some three hundred men have been working on its construction during the past few weeks, and 300 more have been added recently. The Canadian Pacific Railway has run three spur tracks right into the works alongside of the three kilns, making it possible to load and ship bricks immediately they are dried. Construction of the gas plant is also well-advanced, and should be easily finished by May 1, at which time the company expects to commence operations.

The Ontario National Brick Co. is the new brick company organized a couple of months ago by interests closely connected with the National Brick Co., of La Prairie. The capital issued is \$2,000,000 common stock, which is the full amount of authorization; and there have also been issued \$1,250,000 40-year six per cent. first mortgage bonds. The board of directors is made up of the following gentlemen: J. N. Greenshields, K.C., Thos. Long, J. W. Pyke, Hon. Robt. MacKay, and John McKergow.

MACHINE SHOP METHODS ^A_N^D DEVICES

Unique Ways of Doing Things in the Machine Shop. Readers' Opinions Concerning Shop Practice. Data for Machinists. Contributions paid for.

INDEX MILLING FIXTURE.

By A. L. Monrad.

IN THE illustration is shown the design of a milling fixture which had to have a number of cuts taken at different angles as indicated at (A). The base block (B) is machined all over. In its centre a 1-inch hole is bored to a turning fit for the jaw holder (C). On the end of the block is located a hardened screw bushing (D). On one end of this bushing is recessed a 1/2 inch hole for location of a spiral spring (E). Through the other end of the bushing slides a hardened, ground and lapped locating plug (F), with a knurled thumb handle on the end. This is secured to the plug with a centre screw (G). This plug enters into one of the four holes of the jaw-holder (C), serving to locate the position of the jaws when milling.

The end of the moveable jaw is the novel feature in the device. A cam was designed in such a way that it draws the jaw back and forth. A plate (M) is held on the movable jaw with a shoulder screw. In this plate is milled an elongated slot, just long enough for the cam handle (N) to draw up solid against the work. In so doing, the pin (O), which is driven in the cam handle, is free in the bottom of the slot. On the return of the cam lever the pin strikes the other end of the slot and draws the jaw back from the work. This fixture is placed on two parallels in a vise on a hand milling machine. By releasing the plug (F) from its index hole the jaw-holder is moved round to the next hole by the handle (I). The plug will locate itself in position as the point is slightly tapered to allow for wear and tear.

gauge that the inspector can operate instantly and one that will absolutely assure him that all work passing through his department is in perfect shape.

In order to overcome the defects of previous designs the receiving gauge here shown was decided upon. It enables the inspector to see clear through and on both sides, so that he is assured of the proper angle. A very slight variation can be instantly detected. To relieve the inspector of the weight of the gauge, the latter may conveniently be placed upon a wooden stand before a window in such a way that one of the arms stands upright, as shown. At night an electric lamp is used.

The frame (B) is made of machinery steel, casehardened. It is lapped on the bottom and both sides to a true surface. At the centre of the frame a hole is bor-

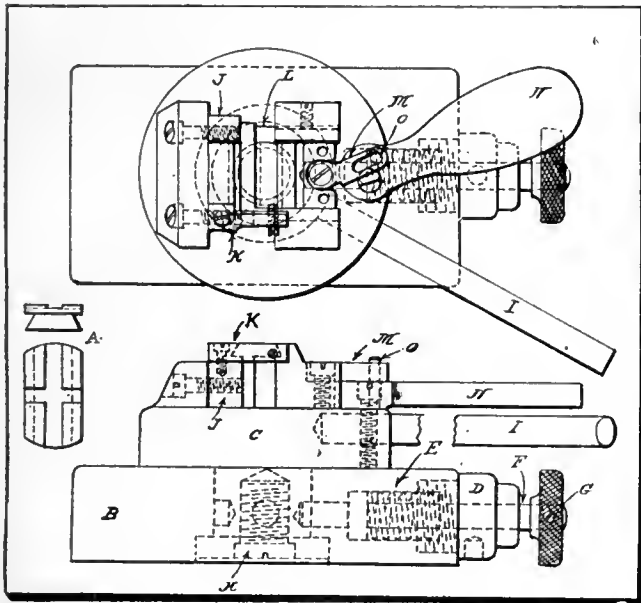

AN INDEX MILLING FIXTURE.

The holder is held in position with a T-head screw (H) and a washer. The shoulder is faced off to a turning fit and the jaw-holder (C) is revolved by the handle (I). On top of the holder is located one stationary and one movable jaw. The stationary jaw (J) is held in place with two fillister screws. On top of this jaw is secured a stop-plate (K) with an adjusting screw for setting the work in proper relation to the cutter. The moveable jaw (L) is bevelled on the sides to an angle of 15 degrees to form a sliding fit in the holder. A gib between it and the wall provides for adjustment.

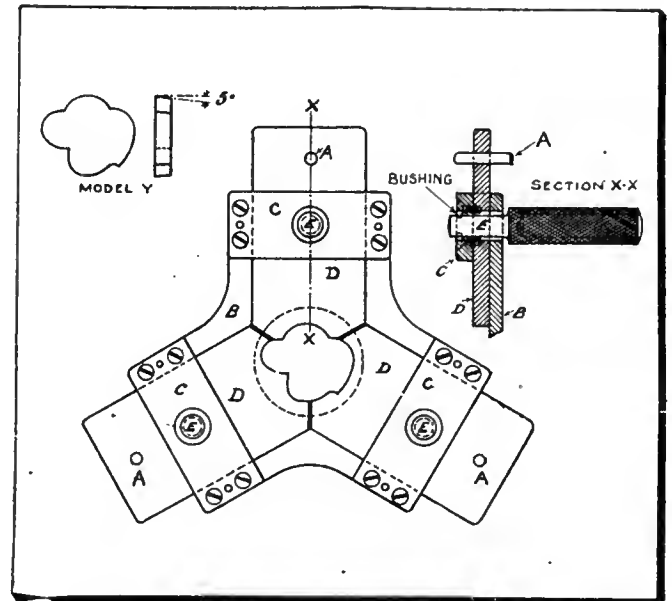

A RECEIVING GAUGE.

A RECEIVING GAUGE.

By A. L. Monrad.

THE illustration shows a receiving gauge for inspecting the model (Y), which forms part of a counting machine and is tapered 5 degrees on all sides. The making of this piece presents many difficulties, but it is still harder to gauge it accurately, as it has to be absolutely accurate all round, both as to shape and taper. The ordinary push receiving gauge answered the purpose fairly well, except that the inspector could never be sure of the correctness of the angle. When it comes to handling thousands of pieces it is very essential to have a

ed a little larger than the diameter of the work to be gauged, in order to let the tight through. This hole is shown by the dotted circle. On top of the frame (B) the plates (C) are secured by four fillister-headed screws and two dowel pins in each. These plates are also case-hardened and lapped to a true surface on their bottom side. The slides (D) are lapped on all four sides to a push fit in the frame, and, like the latter, are of casehardened machinery steel. The pins (A) are used as a handle to slide (D) to and fro. These slides are held in position by hardened ground and lapped plugs (E) and bushings, as shown by the

make the machine (A) Fig. 2. This consisted of a cast iron wheel (C), grooved to suit the outside diameter of the pipe (B). A wrought iron forked lever (D) was made, and two cold rolled pins (E)

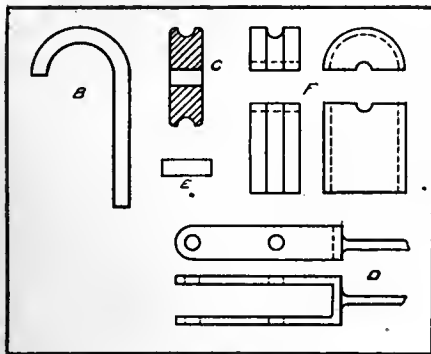

FIG. 1. PIPE BENDING DEVICE.

formed the spindle of wheel (C) and the fulcrum of lever (D). The hardwood block (E) was made in two pieces, the semi-circular portion being turned separately and afterwards fastened to the larger part.

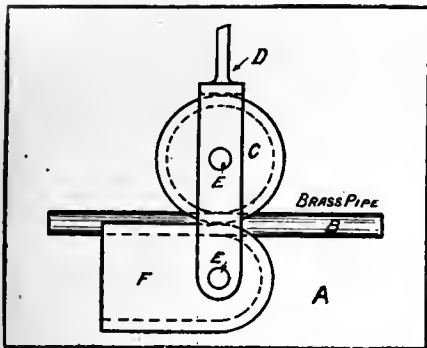

FIG. 2. PIPE BENDING DEVICE.

The method of usage is shown by Fig. 2. The pipe (B) and hardwood block (F) are secured in a vise. Pressure is applied through the lever (D) and the pipe is thus bent to the desired shape. This device has proved very satisfactory and the same arrangement could doubtless be used in other shops to advantage.



A LATHE TRUCK.

By Avery E. Granville.

THE Le Blond Machine Tool Co., Cincinnati, Ohio, use the truck shown in the accompanying halftone to move finished or partly finished lathes from place to place in their factory. The body of the truck is of cast steel with two heavy 14-in. cast iron wheels placed on a steel axle in the middle. A 6-in. wheel is carried in a swivel at each end, these wheels being set high enough above the middle wheels to insure

only three wheels being on the floor at one time.

The lathe to be raised and moved, is elevated by means of three cut steel screws, the nuts for which have sprocket teeth cut on the outside, so that they may all be connected together by a bicycle chain, and all worked in unison. Two of these screws carry one of the cross-pieces, there being one at each end, so that the lathe is held steady with no tendency to tip. The third screw is set in the middle of the cross-piece it carries, and the nut on it not only has sprocket teeth like the others, but also has bevel gear teeth cut on its lower side into which the teeth of a bevel pinion mesh. This pinion is carried on a small shaft having a crank at one end, so that a workman can easily run the screws up or down by turning the handle. Only a few seconds are required to run this truck under a lathe, run up the screws till the lathe is well off the floor and then push it wherever desired. For light lathes, only one man is needed to do the work, but, if the lathe is a heavy one, two or more are required. This device is the quickest operated and saves more time than any the writer has seen.



A DIVIDING HEAD AS A DRILL JIG.

By J. H. R.

THE accompanying sketch illustrates a useful means of using an old dividing head as a jig for the drilling machine. The cut shows the jig being used for drilling a series of equidistant holes on concentric circles in a perforating die. The work arbor (e) is fitted to the hole in the dividing head and its upper end is made to suit the requirements of the work in hand,—in this case, the round steel disc as shown at (a). The gauge

(c) is secured to the body of the head (d) and overhangs the die-plate, as shown in Fig. 1. Holes are drilled in the piece (c) to conform with the required radii of the different rows of

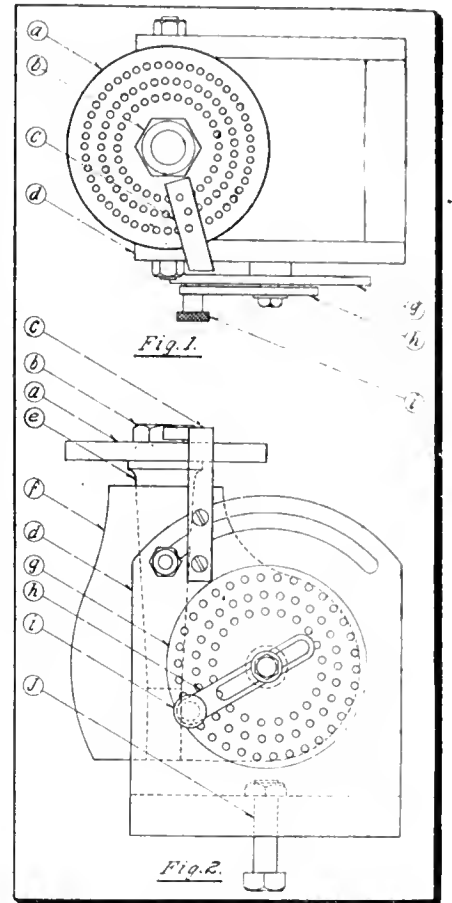

DIVIDING HEAD AS A DRILLING JIG.

holes. By the ordinary method of division with the use of the spacing crank (h) and disc (g) the holes in the die (a) are spaced equidistant and in concentric circles.

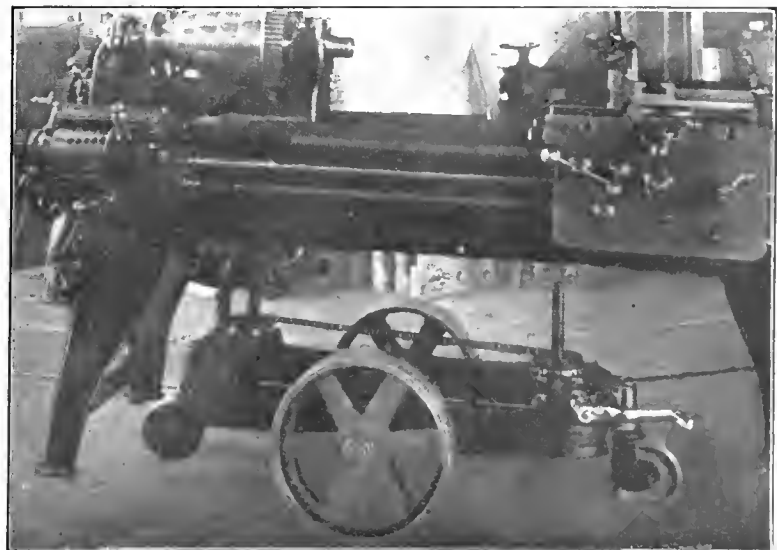

A LATHE TRUCK.

DEVELOPMENTS IN MACHINERY

A Record of New and Improved Machinery Tending Towards Higher Quality and Economical Production in the Machine Shop, Blacksmith Shop or Planing Mill.

HIGH DUTY TOOL ROOM LATHE.

THE tool room lathe which we here illustrate is a recent design of the American Tool Works Company, Cincinnati, Ohio, and is built in 14-inch,

constructed to avoid the spring and inconvenience sometimes found in such a device. All parts are amply heavy and numerous sliding joints have been avoided, thus insuring a rigid meehan-

be found in taper attachments directly connected with the cross feed screw. The cross feed nut is always connected with the tool rest, so that it cannot fall to one side and out of position.

The "American" relieving attachment has been designed along original lines with a view to making it completely universal in its operation. The result is that end and internal relieving can be readily performed as straight relieving work, such as relieving taps, hobs, cutters, etc. An important feature of this new attachment is that it can be applied to any type of "American" high duty lathe and is not limited to one special type or size. Thus, it can be as easily applied to a lathe with a geared head or a motor drive as it can to one with a cone head drive.

The change gear mechanism is supported by a bracket located at the front of the headstock on top of the quick change gear box. The gear train has a small quadrant which carries the change gears, and which is used to disengage the drive when not required. Power is taken from a spur gear located on the end of the spindle and is transmitted through the change gear mechanism to the driving shaft which extends through the supporting bracket on the quick change gear box and is journaled at the other end in a suitable bracket fastened to the left wing of the carriage. Between this bracket and the tool rest are located the universal or knuckle joints which permit cross movement to the tool slide.

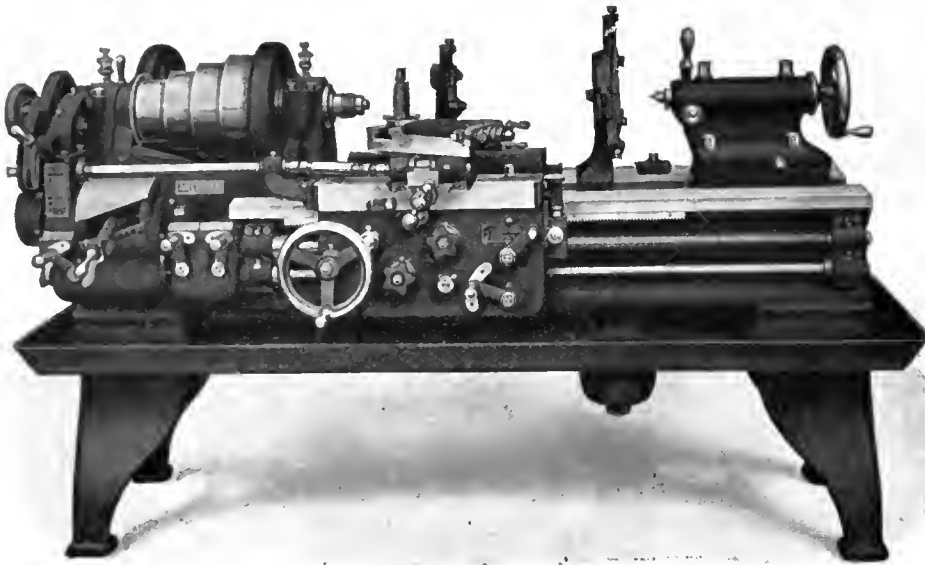

HIGH DUTY TOOL ROOM LATHE.

16-inch, 18-inch and 20-inch sizes. In its general features this lathe is similar to the regular "American" high duty engine lathe with patented drop vee bed, double plate apron patented quick change mechanism, etc.

The chief interest in a tool room lathe centres in the various attachments such as taper, draw-in and relieving attachments. In the lathe under review these have all been designed with a view to efficiency and ease of operation. The taper attachment is con-

ism producing accurate tapers. It is bolted to the carriage and can be thrown into operation at any point along the lathe bed by tightening a single nut. When attached for taper work, the sliding shoe is directly connected with the bottom slide of the tool rest by a heavy cast-iron yoke, making its operation instantaneous, and at the same time doing away with all lost motion, weakness and inaccuracy liable to



INTERNAL RELIEF, HIGH DUTY TOOL ROOM LATHE.

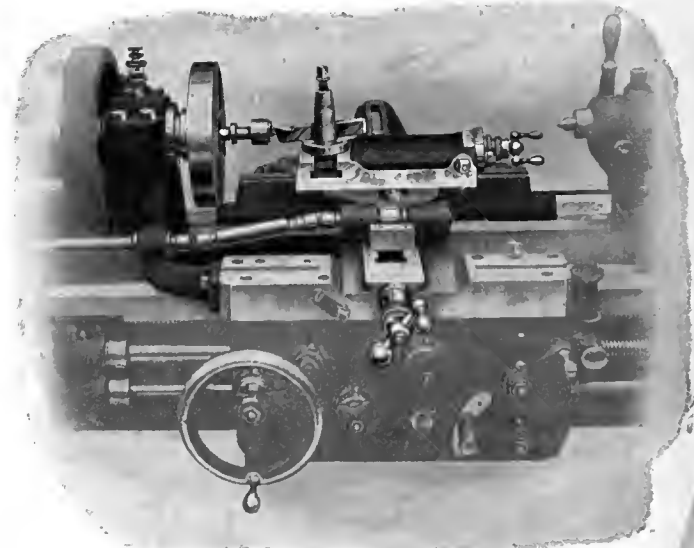

END RELIEF, HIGH DUTY TOOL ROOM LATHE.

The driving shaft revolves constantly in one direction until the direction of the spindle rotation is reversed, at which time the driving shaft ceases to reciprocate the tool slide. This feature is of great value, for by means of it the tool side will remain stationary when the direction of the carriage travel is reversed while the half nuts are engaged. By means of this same feature the tool can be withdrawn from the work and run back for a new cut, as is the practice in tap and hob making, without any waste motion of the parts and with absolute safety to the cams.

Another valuable feature of the attachment is that which permits the tool slide to be operated at every 30 degrees, thus giving twelve operating positions within a circle. It is this feature that permits of relieving side cutters, end mills and numerous similar jobs. When necessary to relieve taps or hobs having spiral flutes, the attachment can be arranged to handle such work by the addition of extra gears.

This tool room lathe is also fitted with a draw-in attachment of simple design, equipped with collets for holding stock up to $\frac{7}{8}$ -inch diameter on the 14-inch and 16-inch sizes, and up to 1-inch diameter on the two larger sizes.



THE NEW STARRETT HUB MICROMETER.

UNTIL recently the only method of measuring hub thicknesses has been to lay a straight edge on one side of the hub and put a steel rule through the bore, reading the thickness on the opposite side from the straight edge. Sometimes, if the total diameter of the wheel or gear was small, a pair of calipers was slipped over and the thickness of the hub calipered in the usual manner.

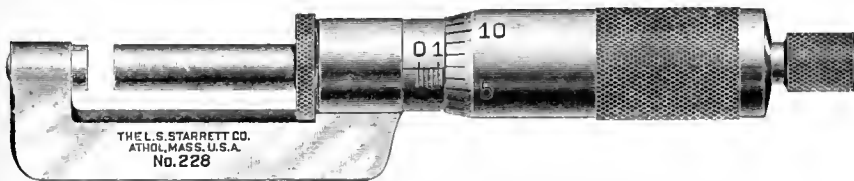

THE NEW STARRETT HUB MICROMETER.

The new Starrett micrometer, here shown, does away with liability of error common with the rule or caliper method, because the measurement is made direct, and the micrometer reading insures absolute accuracy. The chief feature of this micrometer is the frame, which instead of flaring out in a semi-circular form, as do ordinary micrometers, is offset only slightly from the centre line of the spindle. By making the frame narrow, it may be easily in-

serted in holes as small as $\frac{3}{4}$ -inch diameter.

The new micrometer has the combined speeded thumb piece and ratchet stop that have been a feature of other Starrett micrometers, and it also has the lock nut. The speeded thumb piece gives a much smaller periphery for the thumb to turn, which greatly increases the speed with which the micrometer may be set. The thumb piece is also a ratchet which acts as soon as a slight pressure has been applied to the work

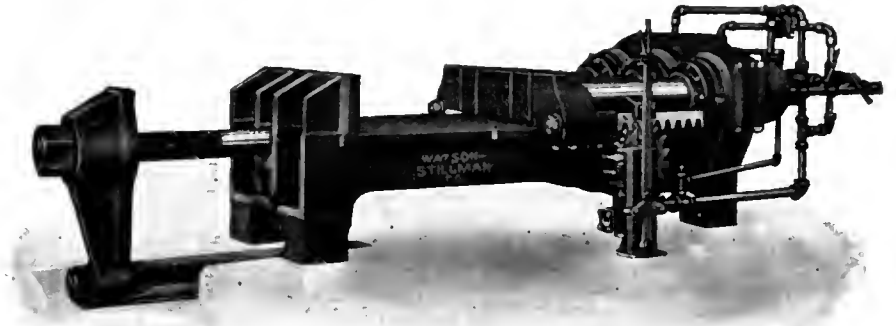

AN HYDRAULIC BULLDOZER.

being measured. This prevents excessive pressure being applied to the work as would be easily possible with a micrometer screw, which has 40 threads per inch. The lock nut is useful to make a gauge of the micrometer, as when a large number of pieces must be made to a certain size.



AN HYDRAULIC BULLDOZER.

THIS machine was recently designed by the Watson-Stillman Company, New York, for manufacturers of heavy axles for automobile trucks, but it may also be used for upsetting or shaping heavy forgings for die press work. For example, a round or square steel bar

by means of the nuts on the two horizontal rods. The correct position of this beam is determined by the length of bar that must project onto the bed plate clear of the face of the rigid cross beam.

A forming die, a cutter, or whatever is needed to give the bar its initial cut or shape is rigidly attached to the moving crossbeam, the face of which is shown in the cut. The four vertical Tee slots in the moving cross beam furnish ample means for attaching dies. A forming or holding die is also placed

against the fixed cross beam to guide or shape the operation. Where many pieces of the same size must be formed, the die is not removed until all pieces are ready for another operation if needed.

A notable feature of the machine is the arrangement of its three rams, all connected to the one head to permit the use of only one, or two, or of all three rams, depending on the pressure necessary. With one ram—the middle one—the capacity of the bulldozer is 56 tons; with the two outside rams, 127 tons; and with the three cylinders in use simultaneously the capacity becomes 200 tons. Stop valves, shown in the piping at the rear, are used for cutting out the cylinders.

The press is completely controlled by the vertical latch lever shown, which operates a 2-inch balanced two-spindle valve. A 5-inch pullback cylinder, not shown, is constantly under pressure to return the moving cross beam to its initial position as soon as the rams are released. The stroke of the rams is limited to 15 inches by positive stops which are strong enough to take up the full pressure. These stops serve as safety devices in preventing excessive upsetting on certain forgings. To allow for eccentric loads on the moving cross beam an equalizing device consisting of two racks and two pinions is provided to insure absolutely parallel motion. One pinion and one rack of this device are shown in the picture.

The following are the principal dimensions: The width of the head plate is 44 inches; maximum opening between

moving cross beam and rigid cross beam, 48 inches; maximum opening between moving cross beams and adjustable stop, 90 inches; length of moving cross beam, 48 inches; diameter of rams, 11 inches; stroke, 15 inches; maximum liquid pressure per square inch, 1,500 pounds; diameter of horizontal extension bolt, 6 inches. The weight of the complete machine is 20,000 pounds.



INSERTED TOOTH METAL CUTTING SAW BLADES.

THE Hunter Saw & Machine Co., Pittsburg, Pa., have recently manufactured two of the largest inserted tooth metal cutting saw blades ever placed on the market. These are known under the trade name of "Hunter Duplex." They are 84 inches in diameter, being made from 1 inch thick plates of the company's own special analysis, and treated to withstand the greatest strain. Two collars, one on each side, 26 inches in diameter by 1 inch thick, are riveted to the body of the saw, and are milled with four equally spaced keyways by which the blades are driven. The plates are milled with forty-four pockets into which are inserted roughing and finishing teeth alternately, weighing $1\frac{3}{4}$ pounds each, and made of the best grade of high speed steel known for metal cutting. Each tooth is reinforced and held rigidly by a tool steel wedge, weighing $\frac{3}{4}$ pounds, inserted at the back of the tooth. At the bottom of the pockets, the plate is drilled and tapped to

admit of a hexagon head brass screw, which is used in setting the teeth to the proper height.

The blades weigh 2,000 pounds each, are driven by 75 h.p. motors, and were

pose of the jobbing as well as the manufacturing shop. It will swing $13\frac{1}{2}$ inches over the shears, and will take work 21 inches diameter by $6\frac{1}{2}$ inches face in the gap.

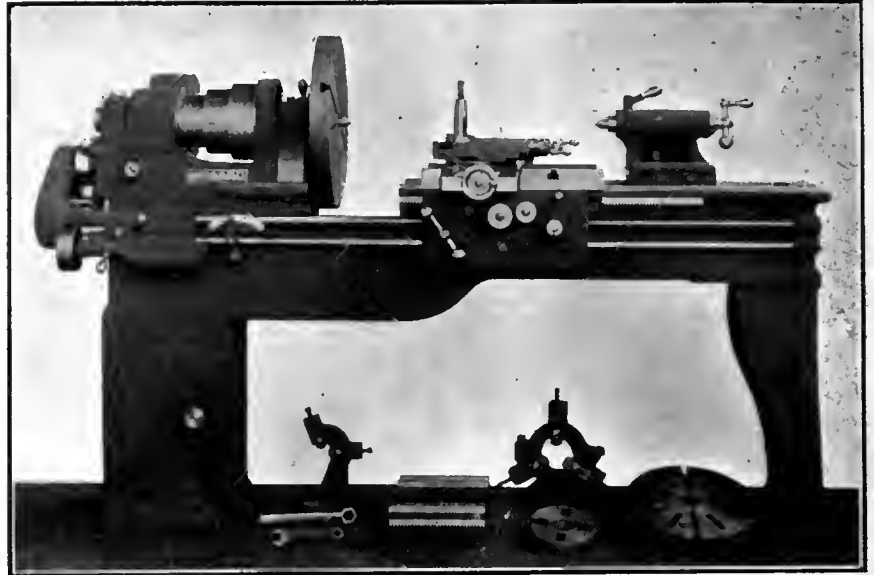

WILLARD GAP BED ENGINE LATHE.

designed for cutting 40 inch ingots. They are capable of cutting 24 inch ingots in ten minutes.



WILLARD GAP BED ENGINE LATHE.

THE gap lathe here shown is a production of the Willard Machine & Tool Co., Cincinnati, Ohio, and is designed and built to serve the double pur-

The crank handle for moving the carriage is at the left hand side of apron, which is unusual in gap bed lathes, as this handle is generally placed at the right hand end of apron, a location more or less inconvenient for the operator. A gib is attached to the carriage at the right hand side of the apron for the purpose of stiffening the carriage when it overhangs the gap. The removable filling piece is scraped and fitted to a bearing in the gap, and when in position transposes the lathe into a regular standard engine lathe equally as convenient for all ordinary work as the regular standard engine lathe. The headstock and tailstock of this lathe are identical to headstock and tailstock of the firm's standard 13-inch lathe, while bed, apron and carriage have had to be changed a little in order to accommodate the gap. This gap bed lathe is furnished in 6, 7, 8 and 10 feet beds, and has a cabinet leg under the headstock end. A cabinet leg for the tailstock end can also be furnished, but the regular outfit has a plain leg under the tailstock end.



NEW MOTOR CAR FUEL WANTED.

A PRIZE of \$100,000, to be contributed by all the chief motor car clubs in the world, is to be offered, says Excelsior, for a new motor car fuel, rendered necessary by the rapidly increasing price of petrol. The new fuel must be easy to manufacture with substances of which there is a constant supply, such as alcohol, and which are not likely to fluctuate in price except with general alterations in money values.

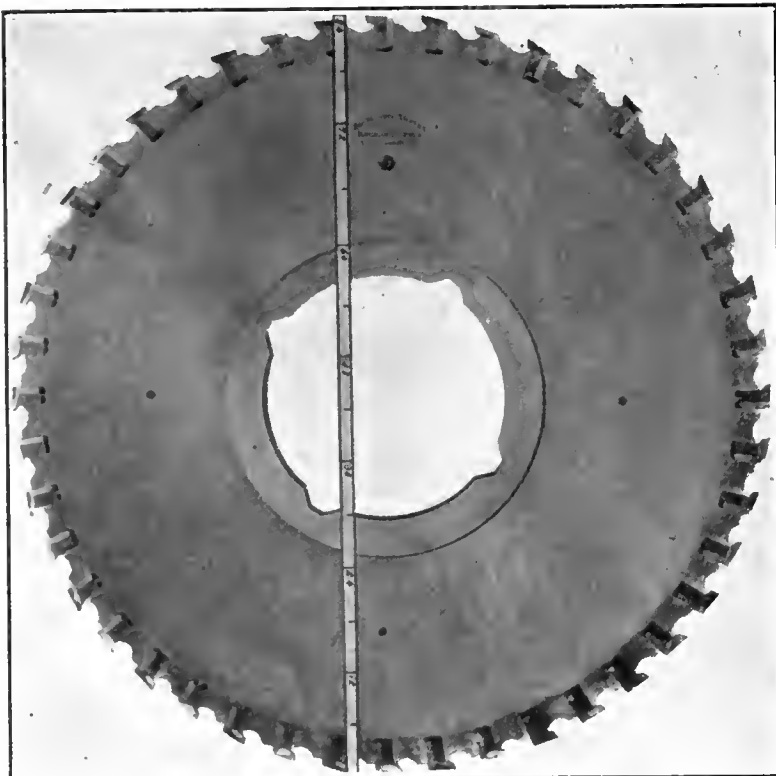

INSERTED TOOTH METAL CUTTING SAW BLADES.

FOUNDRY PRACTICE AND EQUIPMENT

Practical Articles for Canadian Foundrymen and Pattern Makers, and
News of Foundrymen's and Allied Associations. Contributions Invited.

THE BLAIR REMOVABLE SLAG POCKET.

IN the usual operation of the open-hearth furnace, the filling of the slag pockets with slag necessitates the periodical stopping of production for the purpose of cleaning these out. In addition to this cleaning being destructive of the brick work of the pockets, the necessary interruption to the operation of the furnace adds to the tonnage cost of the steel produced. Attempts have been made to overcome the difficulty by providing slag-collecting receptacles inside the permanent walls of the furnace structure, and replacing them when filled by empty vessels; but these attempts have been failures, because the slag adheres to the walls of the furnace and the receptacles cannot be removed without serious damage to these walls. Moreover, men cannot work in the slag pockets, owing to the high temperature.

The illustrations herewith show a removable slag pocket designed by the Blair Engineering Co., New York and Montreal. This pocket forms a removable portion or section of the furnace structure, and may be readily and comparatively speaking, quickly removed when filled, being then replaced by an empty pocket. Fig. 1 shows a longitudinal vertical section of one of the two similar ends of a 60-ton basic open-

hearth furnace provided with this pocket, and Fig. 2 is cross-sectional view. As the cuts clearly show, the slag pocket structure, apart from the arches

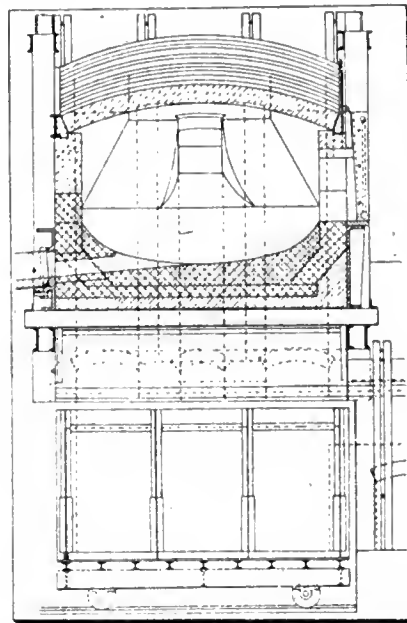

FIG. 2. CROSS SECTION OF 60-TON BASIC OPEN HEARTH FURNACE, SHOWING SLAG POCKET CARRIAGE.

and arch supports, is complete in itself and is quite separate from the remainder of the furnace. It consists, pre-

ferably, of a wheeled truck or carriage, moving on a track at each end of the furnace. Rising at intervals from the bed of the carriage are a number of metal posts, suitably braced, to provide a framework for the brick walls forming the slag posts. The lower ends of the port down-takes are provided with suitable metal binders for supporting the slag pocket arches at this point, so that the arches are entirely separate from the slag pocket walls and are not dependent on the latter for support. When a slag pocket carriage is run into position there is necessarily left a narrow opening between the upper ends of the pocket walls and the down-take walls, and a similar opening between the wall of the flue leading to the regenerative chambers and the adjacent wall of the pocket structure. These spaces are temporarily closed by brickwork to form tight joints connecting the slag pockets with the port down-takes and with the regenerative chambers.

When the slag pockets are full, the jointing bricks are knocked in to destroy the bond between the pocket walls and the permanent furnace walls, but no part of the furnace structure is disturbed in any way. The slag pocket carriage is then withdrawn on its rails and replaced by an empty one, the spaces being bricked up again as before.

Instead of being made up with bricks, the joint may be made by placing a layer of ganister on top of the slag pocket walls and raising the whole pocket tight up against the upper walls by means of four screws at the corners of the carriage, and by blocking in position by means of wedges or supports at the bottom of the carriage. Screws are simpler and better for the purpose than a hydraulic ram, since the lift only amounts to an inch or two, and the operation only takes place once in two or three months.

Hitherto the time taken for the removal of the slag and the rebuilding of the slag pockets and down takes has been from a week to ten days, with the attendant loss of product and that due to the necessary expenditure of a very considerable amount of labor and fuel to bring the furnace back to melting temperature. A Blair removable slag pocket, on the contrary, may be withdrawn and an empty one substituted in a few hours, enabling a large portion of the heat of the furnace to be re-

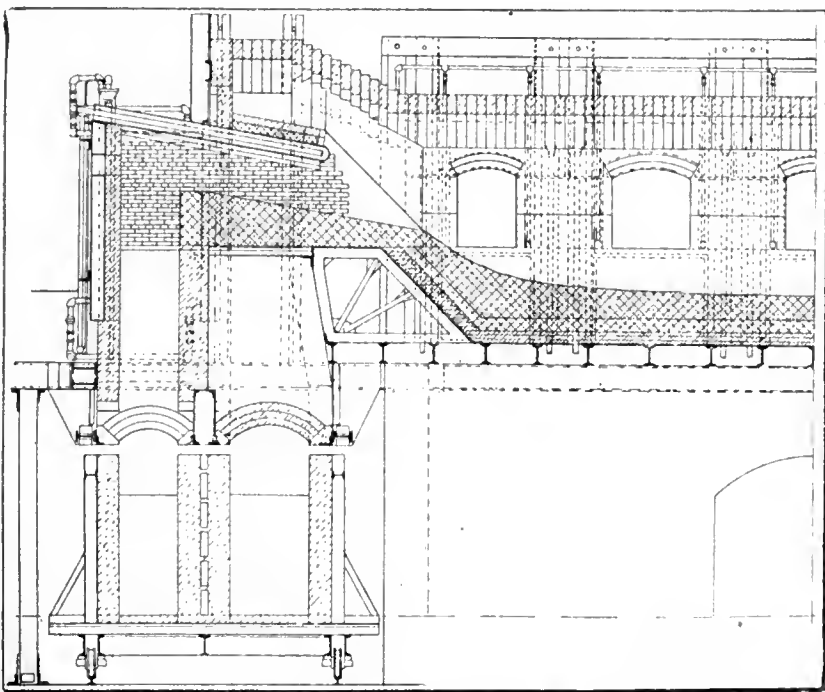

FIG. 1. LONGITUDINAL SECTION OF ONE-HALF OF A 60-TON BASIC OPEN-HEARTH FURNACE FITTED WITH BLAIR REMOVABLE SLAG POCKETS AND INDESTRUCTIBLE PORTS.

tained and normal working conditions restored with a minimum of delay and expenditure of fuel. If the time selected for the removal of the slag pockets be made to coincide with the operation of burning out of the flues, the loss of time due to the removal of the pockets is nil.

The furnace shown in these illustrations is also equipped with the Blair patented port and bulkhead. The most prominent feature of the Blair port invention consists of a hollow water-cooled steel hood, which covers full width and length of the gas port of an open-hearth furnace, permitting the entire blocks of the furnace to be built of magnesite in a basic furnace, and of silica sand in an acid furnace. It forms a septum or barrier, between the incoming gas and air, impervious to the gases and physically and chemically inert, so that the whole end structure of the furnace becomes practically indestructible. Then, too, the hood, by properly controlling the mixture and direction of the gases at all times, greatly retards the burning out of the furnace.

The bulkhead, as shown in the illustrations, consists of a hollow steel water-cooled box, lined on its inner side with magnesite brick, thus insulating the bulkhead cooler from direct contact with the flame. In conjunction with the Blair port this is an additional source of saving, as it eliminates the constant bulkhead repairs necessary where brick alone is used.

Some of the advantages of these inventions, as proved by numerous installations in the United States, and at the plant of the Nova Scotia Steel & Coal Company, North Sydney, N.S., are that an indestructible port, and end block is obtained. As the Blair port is said to always maintain its original alignment, perfect control and direction of the gas is obtained at all times, the life of other parts of the furnace being thereby much increased with consequent reduction of furnace repairs. As there is no silica brick in the end of the furnace to melt down and cut the magnesite bottom, there naturally also follows a material reduction in the cost of bottom repairs. It has been further demonstrated that the port will withstand a temperature on the outgoing end which would destroy a port built in the ordinary way, thereby enabling the furnace to run hotter with a marked gain in the speed of production. Blair ports are to be found in some fifteen of the largest steel plants in the United States. Five of these, including that of the Bethlehem Steel Company, have the whole of the open-hearth furnaces so equipped.

The Blair port patents are owned by the Blair Engineering Company of

Canada, Ltd., 74 Bank of Ottawa Building, Montreal, who have installed these ports in all three of the furnaces of the Nova Scotia Steel and Coal Company, Ltd., North Sydney, N.S. The latter company will also equip a fourth furnace, which they contemplate building, with Blair ports.



CANADA FORGE CO. REBUILDING.

THE Canada Forge Co., Ltd., Welland, Ont., are rushing to completion a temporary building to replace the one burned on Sunday, February 2, and will have a part of their forge department in operation within a week. This will enable them to care for the delivery requirements of their many customers. The contract for the new forge shop has been placed with the Standard Steel Construction Co., and is specially designed for the manufacture of forgings up to 40,000 pounds in weight. The general dimensions of this building will be 100ft. x 200 ft., with centre bay equipped with 20-ton electric crane of 60ft. span, with two bays each to be served with 5-ton electric crane, 20ft. span. At the end of this building and continuing a distance of 100ft. there will be constructed a 50ft. span electric crane runway of 20-ton capacity for handling raw materials and shipping. This will not only insure against further interruptions in production on account of fire, but will greatly increase the scope of the work. Equipped as it will be with steam hammers, hydraulic forging presses, annealing and heat treating furnaces, this forge will be one of the finest on this continent.



STEEL PLANTS AND TARIFF PROSPECTS.

THERE has been a great deal of curiosity at Ottawa as to whether the budget speech when it is brought down late in this month or early in March will contain any concessions to the steel interests. Following the example of his predecessors, Hon. W. T. White, the Finance Minister, is keeping his own advice, and it is not likely anything will definitely be known as to the policy of the government until he makes his announcement. The steel men have made several pilgrimages to Ottawa to lay their claims before the Government, and it is understood that they have asked either for increased duty or for a commission of some kind to investigate their claims. The request for a return to the bounty system, it is said, has been abandoned, and there is general impression at Ottawa that the present rate of duty

will prevail for another year. There is undoubtedly a strong radical wing in the Conservative party, consisting mainly of Ontario and Western members representing rural ridings, who are opposed to further concessions to the steel interests. They point out that the mills are so busy at present that they are unable to take care of the Canadian business.

Some Inside History.

In view of the revival of the question of a higher duty, a little history as it is told at Ottawa is interesting. It is said that the Government last session, decided to renew the steel bounties for another year pending the appointment of a tariff commission which would make a thorough investigation. The decision of the Government was laid before the Conservative caucus and then the fun began. Arthur Meighen, the clever young member from Portage la Prairie, is credited with being the leader of the insurgents and the objection was so determined and so vigorous that the matter was dropped. Now these same objectors have not, according to their statements, freely made in the lobbies, changed their views in regard to the steel question and the government is well aware of the fact, therefore, no matter what its own views, it has to reckon with this radical element. The general opinion is that in view of all these circumstances the steel men will have to be content with the status quo. If a tariff commission is ever appointed—and there is a strange silence on the subject—the steel men can then make their representations to it.

A side-light on this same question is a rumor to the effect that the United States Steel Corporation were given to understand that if they wanted to do business in Canada, they must build a Canadian factory, hence the announcement of their new Sandwich plant. Otherwise, the tariff would be adjusted so that they would have to get out of the market. With the United States Steel Corporation operating in Canada on an even basis with other Canadian concerns, many of the objections of the Eastern companies would be removed, as it was the alleged dumping in Canada which was their strongest argument for a higher duty.



ENGINE MAKERS ASSIGN.

THE Sherman-Cooper Co., Ltd., of Toronto, have made an assignment to Mr. Osler Wade, assignee. The company are manufacturers of gasoline engines chiefly, and their plant is situated at No. 1011 Eastern avenue. The assets and liabilities are not known as yet, and are to be determined at a meeting of the creditors, shortly.

FOUNDRY CONVEYER SYSTEM.

THE Massey-Harris Co., Ltd., of Toronto, Ont., have installed a system of conveyers, one of which carries coke to an upper run, from which it discharges to a belt conveyer serving the east cupolas, or into a hopper serving the charging cars of the west cupolas.

This conveyer-elevator has a horizontal run of 20 feet. Coke is delivered to it through a hopper at the base, whence it is raised to the upper run. It consists of "V"-shaped buckets carried on steel or malleable chains, and rigidly attached to the links. These buckets are upright on the ascending run, but on the horizontal run, they push the coke along in a steel or concrete trough, so that by opening a gate in the bottom, the material may be discharged.

Figure 1 shows the buckets in the act of pushing the coke towards the belt conveyer. The latter is 18 ins. wide, 350 feet between centres, and runs horizontally along the top of the building. For the greater part of its length, delivery is made into a chute serving the cupola charging cars.

Conveyer in the Basement.

A conveyer independent of the other two is located in the basement of the foundry, and is seen in Fig. 2. It delivers sand, coke, and broken stone from the track hopper into several of the

storage bins. This is also an 18-inch belt conveyer, 50 feet between centres, driven at the tail end from a five-horse power motor suspended from the ceiling.

their accumulation on the return carriers and keeping the different materials carried from becoming mixed one with the other. This cleaning brush is a



FIG. 2. CONVEYER IN BASEMENT.

This motor also drives the 24-inch, 13-foot apron feeder, which is located on the other side of the basement wall beneath a 12-foot track hopper.

At the head end of the conveyer is located a rotary cleaning brush, which cleans the return belt, removing the fine sand and the coke dust, preventing

standard arrangement, and is always located at the head end of the conveyer directly back of the head pulley. It is driven from a sprocket on the head shaft. The mechanism is self-contained and dust-proof, and may be applied to any size brush or any size of conveyer. A web sprocket is used, east integral with an internal gear, which meshes with a pinion on the brush shaft. An adjustable weighted lever arm provides the proper tension for the brush against the belt, and automatically takes up the slack as the brush wears down.

This conveyer system, consisting of four conveyers, was manufactured by the Stephens-Adamson Mfg. Co., to meet the special requirements of the Massey-Harris Co. The entire equipment was designed by Mr. Edwin J. Banfield, 120 Adelaide St., West, Toronto, who is the special representative of the Stephens-Adamson Mfg. Co. in Ontario.



CANADIAN CIVIL ENGINEERS.

THE following officers were elected for the ensuing year at the concluding session of the Canadian Society of Civil Engineers at Montreal, Jan. 30: President, Phelps Johnson, Montreal; Vice-President, F. C. Gamble, of Victoria, B.C.; Members of Council, Messrs. J. M. F. Fairbairn, W. J. Francis and R. J. Durley, Montreal; F. A. Bowman, Halifax; W. D. Baillairge, Quebec; S. J. Chapleau, Ottawa; H. G. T. Haultain, Toronto; W. A. Duff, Winnipeg, and T. H. White, Vancouver.

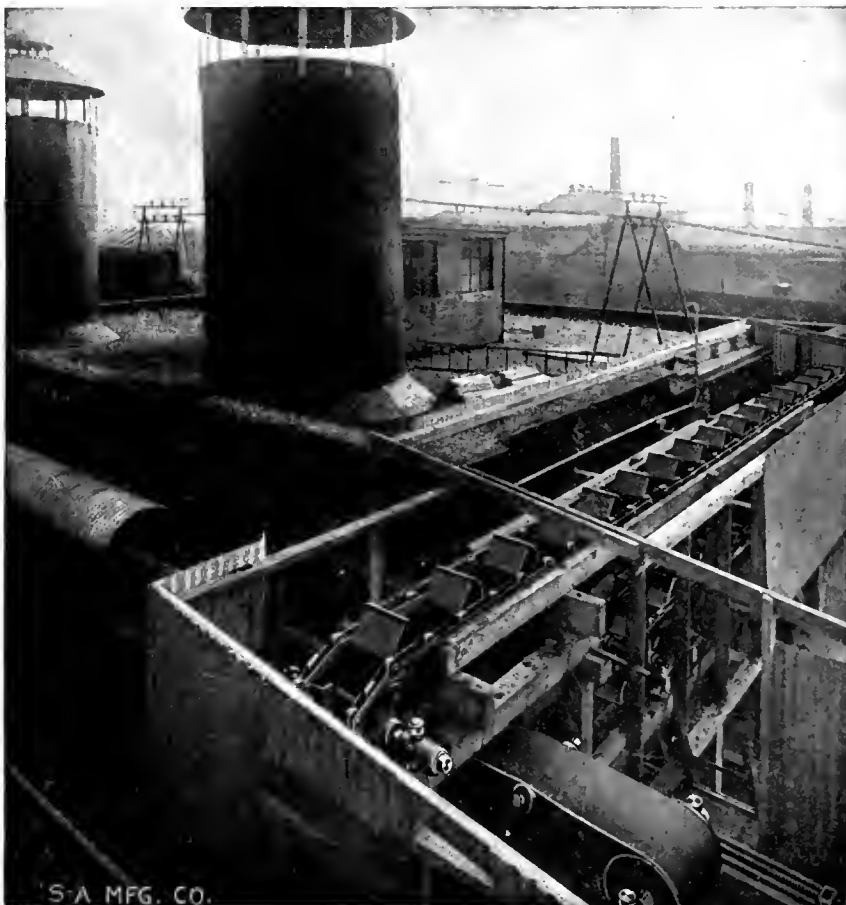

FIG. 1. CONVEYER-ELEVATOR AND BELT CONVEYER.

The MacLean Pub. Co., Ltd.

(ESTABLISHED 1888.)

JOHN BAYNE MACLEAN - - - - - President
H. T. HUNTER - - - - - General Manager

PUBLISHERS OF

CANADIAN MACHINERY AND MANUFACTURING NEWS

A weekly newspaper devoted to machinery and manufacturing interests, mechanical and electrical trades, the foundry, technical progress, construction and improvement.

H. V. TYRRELL - - - - - Business Manager
PETER BAIN, M.E. - - - - - Editor
J. H. WILLIAMS - - - - - Associate Editor

OFFICES:

CANADA
Montreal, Rooms 701-702 Eastern Townships Bank Bldg.
Toronto, 143-149 University Ave., Phone Main 7324
Winnipeg, 34 Royal Bank Bldg., Phone Garry 2313
Vancouver, 11, Hodgson 2649 Third Ave. West.

GREAT BRITAIN
London, 88 Fleet Street, E.C. Phone Central 12960
E. J. Dodd

UNITED STATES
New York, R. B. Huestis 115 Broadway, New York, N.Y., Phone 2209 Rector
Chicago, A. H. Byrne Room 607, Marquette Bldg. 140 S. Dearborn St., Chicago

CABLE ADDRESS:

Macpubco, Toronto. Atabek, London, Eng.

SUBSCRIPTION RATE:

Canada, \$2.00; United States, \$2.50; Great Britain, Australia and other colonies, 8s. 6d. per year; other countries, \$3.00. Advertising rates on request.

Subscribers who are not receiving their paper regularly will confer a favor on us by letting us know. We should be notified at once of any change in address, giving both old and new.

Vol. IX. FEBRUARY 13, 1913 No. 4

PRINCIPAL CONTENTS.

The Necessity of Efficiency in Office and Foundry	131-133
Standard Cross Sections	133
Cures for Misfit Employment	133-134
General	134
Grain Elevators for the West....D. C. Substation Design....Mechanical Stoking of Locomotives.	
The Coal Resources of the Dominion an Empire Asset.....	135-137
Air Operated Hydraulic Pit Jack	137
Railroad Car Equipped with Edison Cells	137
Drawing Office Efficiency and Economy	137-138
Knots and Slings	138-139
Recent Judicial Decisions	140
General	140
Grain Shipments Ahead of Last Year....Waste of Natural Gas in Canada....Fort William....Ontario National Brick Co.	
Machine Shop Methods and Devices	141-143
Index Milling Fixtures....A Receiving Gauge....A File Card Attachment....A Pair of Cutting-off JawsSizes Across Flats and Corners....Pipe Bending Device....A Lathe Truck....A Dividing Head as a Drill Jig.	
Developments in Machinery	144-146
High Duty Tool Room Lathe....The New Starrett Hub Micrometer....An Hydraulic Bulldozer Inserted Tooth Metal Cutting Saw Blades....Willard Gap Bed Engine Lathe.	
Foundry Practice and Equipment	147-149
The Blair Removable Slag Pocket....Canada Forge Co. Rebuilding....Steel Plants and Tariff Prospects.... Engine Makers Assign....Foundry Conveyor SystemCanadian Civil Engineers.	
Editorial	150
6 Ton Truck Makes Heavy Haul....High Power Portable Electric Drills	151
Industrial and Construction News	152-156
New Incorporations....Miscellaneous	156-158
Personal....Obituary....Calendars	158
Calendars....Catalogues	159
General Market Conditions and Tendencies	160
Selected Market Quotations	161-162
General	162
Preliminary Arrangements for Foundrymen's Convention....Canadian Trade Outlook Bright....New System of Excitation....W. S. Iron Ore Production in 1912.	

COMPETITION FOR NEW INDUSTRIES.

IT is not an uncommon thing nowadays to see from the newspapers that small towns like Slossville have just secured a new industry, owing to the enterprise displayed by their board of trade; the report generally adding, that great credit is due. How did they manage it? Usually it runs this way:—"The town will make the new concern a loan of \$50,000 for fifteen years, together with whole or partial tax exemption, and will give them a free site of twelve acres. In return, the company agrees to spend probably the above sum on their factory, which will employ 60 men this year, 75 next year, and 100 the next. These latter, adds the Slossville "Intelligencer," will be new citizens. Almost every other town of any size in the province has been competing with Slossville to obtain this splendid new industry. The press in the various towns have noted it a sure thing, as the offer made by their particular city council has been so liberal, it could not be ignored. After all, Slossville got it, because it made the highest bid."

What is the result of this mad competition for new industries? Small towns are crippling themselves for years to come in their efforts to add a few hundred souls to their population, and are putting themselves in a position to be unable to give justice to any new industry that might wish to locate there. Slossville, by giving a free site, is setting a standard which other towns must come up to, and has given partial exemption from taxation, which the next concern that comes along will demand with equal justice.

The case of an Ontario town is interesting. Its council invited some capitalists to build their plant within its limits, and gave certain concessions. The capitalists spent all their capital on the new factory, and when they were through, the town had to submit a by-law to the people to supply money for running expenses. This happened only a week ago

Canada has acquired such a fame for free sites and exemption from taxation, that British and American capitalists come here, and literally hold-up the ambitious cities one after another, until they have obtained the greatest possible privileges from each, after which they decide to locate. This is particularly true of Western Ontario and the provinces farther west. In the East, conditions are a little different. An American firm recently wrote to the city council of Maisonneuve, Que. (a city which is as hot after industries as any in Canada), and promised to locate within its bounds if they were offered a free site. The application was read at the council meeting, and received with laughter; the secretary being instructed to inform the applicants that there were no free sites in Maisonneuve.

Reference has been made to Maisonneuve, a purely French-Canadian city in Quebec. It is often said that the French are not enterprising; but here is a city which in the past few years has secured some of the best industries that have come to this country. It is a city which laughs at free site seekers, yet it will spend enormous sums advertising its exceptional advantages, and we venture to say that the advantages of Maisonneuve are in no way superior to those of Slossville. The difference is here, however:—Slossville secures an industry by jeopardising itself for years to come, while Maisonneuve draws the best by merely telling in a widely read and trustworthy Machinery Journal, why manufacturers should locate there. A plain statement of facts will appeal more to the concern worth while, than the offer of a free site.

A 6-TON TRUCK MAKES A HEAVY HAUL.

THE 6-ton motor truck shown here-with is fitted with an interesting type of hydraulic transmission. It is known as the La France hydraulic truck. The motive power consists of a gasoline engine directly connected to a pump which has five cylinders arranged radially around a common crank shaft. This pump delivers oil to two oil motors of somewhat similar design to the pump, each motor being connected to one of the rear wheels by a chain.

Forty-six tons were recently hauled by one of these trucks up Broadway, New York to 59th street and across 59th street to 67th street and the East River. The truck, itself weighing 4½ tons, was loaded with six tons of boiler fittings; while behind was attached a wagon weighing 12½ tons and carrying a boiler weighing 23 tons, which came from the Municipal Building at City Hall. At least twenty horses, it is said, would have been required to haul this load. These twenty horses would have occupied at least 250 feet on the streets of the city and would have effectively blocked all traffic while they were passing. The La France truck is only twenty feet long, so that there was over 230 feet of street space saved. Further than that the run was made with the truck in probably half the time that horses would have taken.

This run tends to prove that the hauling of heavy materials through the streets of large cities by motor trucks, either with or without trailers, is an advantage both to the user of the truck and to the general public. It is claimed that, but for the hydraulic transmission of the La France truck, it would have been impossible to start and stop with such a heavy load, without straining some of the parts of the truck. In fact it is said that one cannot overstrain this truck, because the pump is fitted with a relief valve which acts before the car gets overloaded.

The La France hydraulic truck is handled by the Hydraulic Truck Sales Co., 1777 Broadway, New York.



HIGH POWER PORTABLE ELECTRIC DRILLS.

THE Standard Electric Tool Co., Cincinnati, Ohio, has developed and is now placing on the market new universal portable electric drills in five sizes: ¼ in., 5-16 in., ½ in., ¾ in. and 7/8 in. These are in addition to their ¾ in. size



HIGH POWER PORTABLE ELECTRIC DRILL.

illustrated and described in our column in November last. These drills operate off a lamp socket on both alternating and direct current, and they will also run satisfactorily on low frequency circuits as well as on 60 cycles. Series commutating type motors of special design are used. High power and absence of any tendency to run hot are noteworthy features. An improved method of force ventilation is also used.

A prominent feature is that these motors are non-racing; that is to say, they will not race when running idle or under light load; consequently twist drills are never burned, and there is no damage, if tools are allowed to run idle indefinitely. A quick make and break switch is located in the handle, placing drills under control of operator at all times.

All armature spindles run in ball bearings. In the ½ in. and ¾ in. sizes, the gears are mounted on ball bearings encased in grease. The very highest grade bearings are used, and the most improved and best ball bearing practice is employed. All gears are supported on both ends, not studded to gear plate. The gears are generated from chrome nickel steel, case hardened and encased in grease.

These tools are intended for the hardest possible continuous service, and are said to be capable of standing the most rigorous use.



CAN. GEN. ELECTRIC IN THE WEST.

Mr. Fredric Nicholls, president of the Canadian General Electric Co., recently returned to Toronto from a visit of inspection to the company's Western Canada and Pacific coast branches. He reports business very satisfactory in the West, and states that it is intended to largely increase the size of their present office and warehouse building in Vancouver, requirements having outgrown the existing accommodation. The company has opened a branch in Victoria to take care of the business in Vancouver Island, and the plans of a five-storey office and warehouse building in Calgary have been approved, on which construction will commence as soon as the weather permits.



It has been computed that in some cases there are as many as two billion cutting points at work each minute on the face of a grinding wheel; eight hundred million per minute is not uncommon, and four hundred million per minute is quite common. When a grinding wheel is revolving at a cutting speed of about 6,000 lineal feet per minute, it will be readily seen why, in some cases, it can remove metal more quickly than the milling cutter or lathe tool.

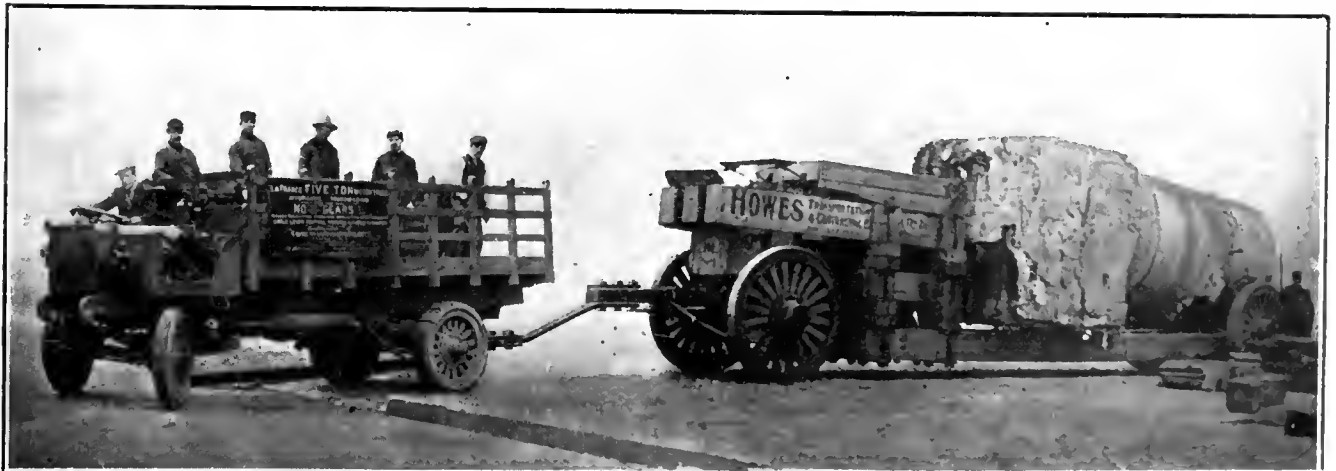

VIEW OF THE LA FRANCE TRUCK WITH ITS OWN LOAD AND THE TRAILING LOAD.

INDUSTRIAL ^A_N^D CONSTRUCTION NEWS

Establishment or Enlargement of Factories, Mills, Power Plants, Etc.; Construction of Railways, Bridges, Etc.; Municipal Undertakings; Mining News.

Engineering

Hamilton, Ont.—Extensive improvements are being planned for the B. Greening Wire Co.'s plant.

Fort William, Ont.—The National Tube new plant for the manufacture of pipe will be ready by the fall.

Montreal, Que.—The Canada Foundry Co. contemplate building another foundry, and are preparing plans.

Hamilton, Ont.—The Brown Boggs Co. will commence additions to their factory, costing \$40,000, in the spring.

London, Ont.—A motor fire truck, costing \$7,500, is required by the City Council, to be delivered May 31st, 1913.

Trail, B.C.—New machinery will be installed at the "Silver King" Mine, Trail, B.C., by the Consolidated Mining and Smelting Co.

Vancouver, B.C.—Repair shops may be built at North Burnaby by the British Columbia Electric Railway to employ 450 to 600 men.

Sarnia, Ont.—A factory, to cost \$7,000, is planned for the Sarnia Bridge Co. It will be a one storey, reinforced concrete and steel structure.

Revelstoke, B.C.—The Consolidated Mining and Smelting Co. will erect a new reduction plant for zinc ores. The estimated cost is about \$5,000,000.

Galt, Ont.—Canadian Motors, Ltd., are interested in the establishment of a motor works. The new company will start with a capital of \$100,000.

Winnipeg, Man.—The Vulean Iron Works, Ltd., advises that it has made an addition to its foundry, 100 x 132. Its output is now about 40 tons per day.

Guelph, Ont.—The Page-Hersey Iron, Tube and Lead Co., Ltd., are planning early extensions to their plant. These will include nipple and bedstead tubing departments.

Regina, Sask.—The Minneapolis Steel Machinery Co. have been granted a site by the City Council on condition that they build a warehouse to cost between \$50,000 and \$100,000.

Niagara Falls, Ont.—A site has been purchased by the Niagara Falls Furnace

Co. upon which a plant of two buildings will be erected. E. T. Williams, Niagara Falls, Ont., is interested.

Welland, Ont.—Silver ore from Cobalt is reaching the Metals Chemical Co. plant, which will begin operations this week. The interior equipment has been installed.

Hamilton, Ont.—Permission is asked by the United Coke and Gas Co., Pittsburgh, to establish a by-product coke plant in conjunction with several gas companies.

Toronto, Ont.—Three and a half acres of factory land have been purchased by Mr. W. G. Harris, of the Canada Metal Co., from Mr. H. W. Petrie, of the Petrie Machinery Co.

Petrolea, Ont.—The Petrolea Valve Cap Factory, which was recently burned, will be rebuilt. New gas engines, dies, presses, general tools and pumping outfit will be required.

Welland, Ont.—Additional equipment is being put into the plant of the Billings-Spencer Co., including a chill press and drop hammers. The new boiler house is nearing completion.

Hamilton, Ont.—The Steel Co., of Canada, will erect a boiler shop, blacksmith shop and locomotive crane shelter at a cost of \$25,000. The Hamilton Bridge Works Co. have been awarded the contract for the steel work.

Napanee, Ont.—The Napanee Iron Works, Ltd., successor to the Dominion Rock Drill Co., are making preparations to build a new boiler shop, which will be equipped with the latest type of machinery.

St. John, N.B.—The Noyes Machine Co., manufacturer of propellers and brass specialties, Portland, Maine, proposes to establish a Canadian plant at St. John, N.B., and has made arrangements for a building.

Hamilton, Ont.—The National Steel Car Co. have booked \$3,500,000 worth of business in the past three months. They have started to deliver cars to the C. P. R. on an order received from that company amounting to \$1,500,000.

Montreal, Que.—The Canadian Trust Co. on Monday, February 3, purchased from the Canadian Iron Corporation,

Ltd., the McDougall Car Wheel Works on William Street for \$90,000. The property has an area of 39,696 square feet.

Coldbrook, N.B.—The Maritime Motor Car Co. is constructing a plant at Coldbrook, N.B., for the manufacture of automobiles.

Hamilton, Ont.—R. S. Rider, Secretary of The Canada Steel & Wire Co. admitted a few days ago that the U. S. steel merger had taken over the local concern,

Sarnia, Ont.—The Anker-Holth Co., manufacturers of cream separators, will begin operations at their Canadian plant in a few days, and will employ thirty-five machinists. Lieut. Andre Ruel, the French aviator, will manage the concern.

Brockville, Ont.—Notices were sent out last week, calling the annual meeting of the Canada Foundries and Forgings Co. for Tuesday, February 11, at the head office here. It is understood that the earnings have been very satisfactory.

St. Thomas, Ont.—Negotiations have been completed for the location of a structural steel plant on the Mann farm. The company will be given a loan of \$50,000 for 15 years by the city, and will employ 160 hands, and erect a \$100,000 plant, covering 12 acres.

Sault Ste. Marie, Ont.—Extensions, costing \$12,000,000, will be made at the plant of the Lake Superior Corporation, including blast furnaces, new rail mill, billet mill, another open heart furnace, another battery of coke ovens, dock extensions, transporters, blooming mills and another merchant mill.

Welland, Ont.—The forge department of the Canada Forge Company was completely destroyed by fire on Sunday morning, February 2. The company will erect a larger building to take its place, and in the meantime have put up a temporary structure. The loss of \$35,000 is covered by insurance.

Amherst, N.S.—The Canadian Car and Foundry Co. are making extensive additions to their car building plant, which will require additional horsepower of 500. The freight car erecting shop is now working on 15-ton hoppers for the Dominion Coal Co., on Canadian Northern box cars, and on Interecolonial ballast cars.

Electrical

Toronto, Ont.—The city council may spend \$90,000 on generators to supply \$6,000 kilowatts.

Outremont, Que.—It was announced at a recent council meeting that this town will generate its own electricity in the future.

Medicine Hat, Alta.—The government will install an up-to-date telephone service in this city. Building will commence in the spring.

Port Arthur, Ont.—Two new street cars with trailers are required. The city will take 250 h.p. more from the Kaminstiquia Power Co.

Sarnia, Ont.—The city's Hydro-Electric line will be extended to Sebringville, to supply that village with power. Power will be generated at the local plant.

Calgary, Alta.—The city council is considering the question of adopting trackless trolley cars or motor buses in the residential districts where tracks are objectionable.

Welland, Ont.—The Ontario Power Co. will sell no more power in Welland than is already contracted for. A hydro-electric line may be built to this city from the Falls or Allanburg.

Calgary, Alta.—Mr. R. A. Ross, who was engaged to advise the council on the best method of obtaining power, has recommended a ten-year agreement with the Calgary power company.

Macleod, Alta.—The Canadian Western Natural Gas Light Heat and Power Co. will supply this town with a minimum of 750,000 feet of gas for its power house, at the same rate as it supplies Calgary.

Toronto, Ont.—The civic car lines on St. Clair Ave. will be set in operation as soon as possible. Works Commissioner Harris will purchase requisite land for car barns, buildings, and will secure the rolling stock necessary.

Montreal, Que.—The Cedar Rapids Power Co. have sold to the Aluminum Co. of America, and the Montreal Light, Heat and Power Co., 80,000 horse-power, leaving 40,000 horse-power to be sold out of the first installation of 120,000 horse-power.

Montreal, Que.—The National Hydro-Electric Co. is making application to the city council for permission to enter the city to sell electric power. It will develop 160,000 horse-power at Carillon Falls, thirty-five miles from Montreal.

Grande Mere, Que.—The H. E. Talbott Co., of the Soo have been awarded the construction of a 1,500-foot dam and the installation of a complete hydro-electric system. The contract involves over \$1,500,000, and will employ a thousand men. Over 75,000 h.p. will be developed at the new station.

General Industrial

St. Catharines, Ont.—Upton's, Limited, will erect a new plant here to cost \$45,000.

St. John, N.B.—Work on the foundations of the Atlantic Sugar Refineries, Ltd., has been begun.

Chatham, Ont.—A \$65,000 factory will be erected here this summer by the Dominion Cannery, Ltd.

Berlin, Ont.—The W. E. Woelfle Shoe Company will soon be ready for business in its new building.

Regina, Sask.—The Regina Heating and Sheet Metal Co. have applied to the City Council for a site.

Huntsville, Ont.—The Portland Cement Co. will build a plant at Marlboro, 17 miles west of Edson.

Blenheim, Ont.—The Blenheim Cannery Co. will begin the erection of a new \$40,000 factory as soon as possible.

Ottawa, Ont.—The mica factory of Messrs. Blackburn Bros. was completely destroyed by fire recently, the loss being \$10,000.

The Dominion Waste Co. have moved into their new factory on Paton Road, Toronto. Sythes & Co. are their sole selling agents.

St. John, N.B.—The American Steam Laundry, recently burned at a loss of \$16,000, will be rebuilt. New machinery will be required.

Burlington, Ont.—The Cedar Valley Brick Co. will install a complete and modern brick-making plant at an estimated cost of \$44,000.

North Bay, Ont.—A new factory will be built at Widdifield Station by the Energite Explosive Co., whose plant was wrecked recently.

Sarnia, Ont.—The Imperial Oil Co. will extend its operations in Canada, and has increased its capital stock from \$6,000,000 to \$15,000,000.

Montreal, Que.—The Consolidated Milk Co. will equip a modern cold storage and creamery plant on St. Viateur Street, at a cost of \$250,000.

Arcola, Sask.—The Aerated Water Works Co. has been burned out. The business of the firm is now being conducted from temporary quarters.

West Toronto, Ont.—The Mason & Risch Piano Co., have had plans prepared for a new factory of cut stone, mill construction. It will cost \$10,000.

Harriston, Ont.—The Harriston Furniture Co. is having plans prepared for an extension to its factory on Webb Street. Factory machinery and a freight elevator will be required.

Sydney, N.S.—The Sydney Boot and Shoe Co., Ltd., has been organized with a capital stock of \$100,000, and will erect a factory to cost \$50,000. Electric dynamos and machinery will be required.

Medicine Hat, Alta.—The Maple Leaf Milling Co. contemplate erecting an additional flour mill in the West. The present mill is in this city. Formerly it was at Moose Jaw, but was moved when the plant was burned.

Hamilton, Ont.—The Eversharp Pencil Co., St. Paul, Minn., is looking for a site upon which to erect a Canadian factory. H. C. Carson is representative. H. L. Frost, of the Frost Wire Fence Co., Sherman Avenue, North Hamilton, is interested.

Welland, Ont.—Industrial Commissioner McCormick announces that a new company, with a capitalization of \$500,000, will erect a plant for the manufacture of cotton fabric. The contract for the building will be let within thirty days. A site of 20 acres has been acquired. The factory will measure 100 x 250 feet, and will employ 250 hands.

Calgary, Alta.—A million and a half dollars will be spent on a new plant for the manufacture of pottery by the Calgary Clay, Coal and Coke Co., Ltd., recently incorporated. A. F. McLaren, of Toronto, is at the head of the new organization, and with him are associated T. B. Miller, president of the Laurentia Milk Co.; Senator Baird, of New Brunswick, and a number of other Eastern and Western capitalists. The company has an authorized capital of \$2,800,000.

Municipal

Calgary, Alta.—A movement is on foot to quash the \$1,000,000 by-law providing cost of proposed bridge over the Bow River.

Sarnia, Ont.—Tenders are being called by the town for the construction of a quarter million dollar waterworks at Point Edward next summer.

Toronto, Ont.—Application is being made for power to build an 18-ft. subway on Yonge Street and to widen that street at a cost of \$1,300,000.

Collingwood, Ont.—The County Council has set apart \$36,000 for roads and bridges, \$8,000 of the sum to be applied on bridges and \$28,000 on roads.

Taber, Alta.—The burgesses are about to vote on a by-law to raise \$25,000, to be granted as a bonus to the Dominion Stove and Foundry Co., Ltd., who will commence operations here.

Calgary, Alta.—Special legislation will be asked of the Provincial Government to raise \$30,000 by debentures for the purpose of buying motor trucks and equipment for corporation work.

Burks Falls, Ont.—On April 18th a by-law to provide and authorize the issue of debentures for \$88,000 re waterworks extension will be declared passed on the above date unless a protest is made.

Toronto, Ont.—Several Ontario municipalities have asked the Federal Government to assist them to build a municipal radial railway from Toronto to Port Perry. They ask for a bonus of \$6,500 per mile for 68 miles.

Regina, Sask.—On February 25th the following by-laws, among others, will be placed before the burgesses to raise \$825,000 for street railway; \$425,000 for new electric light plant; electric light and fire equipment, \$310,000; \$117,000 re incinerator and garbage equipment; \$622,000 re waterworks extension; \$25,000 for gas mains.

Edmonton, Alta.—On February 24th the following by-laws, among others, will be submitted to the burgesses for ratification:—To raise \$168,386.67 to acquire Government telephone system within city limits; \$484,720, cost of power house and plant; \$453,086.67, cost of electric lighting system; \$1,543,320 for street railway; \$453,154, cost of bridge improvement.

Railways—Bridges

Guelph, Ont.—The Wellington County Council will spend \$50,000 on bridges in connection with a good roads scheme.

Fredericton, N.B.—Tenders are being asked for the construction of a bridge across the Miramichi River to cost \$300,000.

Hamilton, Ont.—Station and railway extension, to cost \$3,000,000 is planned for the Toronto, Hamilton and Buffalo Railway.

Toronto, Ont.—It is said that Messrs. Mackenzie and Mann are at the head of a huge radial railway scheme in Ontario.

Winnipeg, Man.—A company will build an electric railway between Portage la Prairie and this city.

Toronto, Ont.—Owing to congestion and traffic dangers, the city may have the Dundas St. bridge rebuilt.

Montreal, Que.—The Montreal Tramways Co. have ordered 50 ear bodies from the Canadian Car and Foundry Co.

St. Catharines, Ont.—A viaduct across the old Welland Canal, with two vehicular driveways will be required now that the C.N.R. is entering this city.

Welland, Ont.—At a meeting of the directors of the Niagara, Welland and Lake Erie Railway Company last week, it was decided to proceed with extensions at once.

Toronto, Ont.—A plan has been submitted to the City Council by the G.T.R. for a new 26 stall locomotive house with machine shop attached near the foot of John Street.

Quebec, Que.—The Quebec Harbor Commission has ordered three six-wheeled switching locomotives from the Montreal Locomotive Works, for delivery in April.

Saskatoon, Sask.—Work will commence in the spring on the largest reinforced concrete bridge in Canada. The Government will pay two-thirds of the cost.

Brockville, Ont.—The town council and Board of Trade have appealed to the Minister of Railways and Ontario Legislature against the proposed removal of the G.T.R. shops to Prescott.

Toronto, Ont.—The Canadian Northern Ry., between Dec. 15, 1912, and Jan. 15, ordered 250 box ears from the National Steel Car Co., and 100 refrigerator ears from the Mount Vernon Car Mfg. Co.

Victoria, B.C.—Tenders will be called for shortly by the Canadian Northern Pacific Railway Co. for the construction of their line to Union Bay. A new wharf will be built at the latter place. The rails are en route from Sydney, N.S.

Cobalt, Ont.—The Associated Boards of Trade of Temiskaming have petitioned the Federal Minister of Railways and Canals, asking aid of the government in the construction of a bridge over the Quinze River at North Temiskaming, in the northern part of Quebec. The cost of the structure will amount to about \$60,000.

Kingston, Ont.—E. J. Chamberlin, President of the Grand Trunk Railway, has informed the City Council that it would cost about \$1,000,000 to divert the main line through Kingston, and the company cannot, owing to the financial situation, consider it.

New Westminster, B.C.—The Western Canada Power Co., Vancouver, will build a line 17 miles long between Stave Lake and Pitt River for hauling logs to the river. It will later form a part of the electric line planned between Vancouver and Mission City.

Sydney, N.S.—Fifty new steel hoppers of 100,000 pounds capacity are to be added to the rolling stock of the Sydney & Louisburg Rly. this spring. The ears are being built by the Montreal Car Works. Two small locomotives for use around the banking stations are to be secured.

Kingston, Ont.—Application will probably be made at the next session of Parliament for the incorporation of the Ottawa, Rideau Lakes & Kingston Ry. Co. This company proposes an electric railway between the points named, and is reported to have secured about \$250,000 toward the construction of its line. J. S. R. McCann, Kingston, Ont., is a director.

Toronto, Ont.—The Toronto Suburban Street Ry. Co. has laid out a trial line for its entrance into Guelph.

Cochrane, Ont.—The Canadian Central & Labrador Ry. is to apply to Parliament for powers to build a railway from Cochrane in a northeasterly direction to a point near Cape St. Lewis on the Atlantic coast, with a branch line to a point near the mouth of the Hamilton River, Quebec, and also a branch line to the city of Quebec.

Calgary, Alta.—The Western Canada Ry. Co. is to apply at the present session of Parliament for an act of incorporation. The company propose to construct a line to be operated by steam and electricity from Fort Churchill, on Hudson Bay, through Manitoba, south of the Churchill River and north of the Nelson River, to a point at or near Sea Falls, on Nelson River, thence north of Lake Winnipeg, through Saskatchewan to Prince Albert; thence continuing through Saskatchewan and Alberta, in a direct line to Calgary, with power to construct a branch line from a point near Manitoba Lake in Saskatchewan to Edmonton. The company proposes to ply between Fort Churchill and other countries; to construct, operate and maintain docks, wharves, and elevators, and operate telegraph and telephone lines along the whole length of the proposed railway.

Wood-Working

Fort William, Ont.—The C.P.R. Carpenter Shop and contents were burned on Monday, Jan. 13. Damage \$1,000.

Winnipeg, Man.—The Aeme Sash and Door Factory on Rue De Meuron in Norwood is completed and in operation.

North Bay, Ont.—The Expanse Lumber Co. are considering the purchase of sawmill machinery for use at Haileybury, Ont.

Grimsby, Ont.—A factory for making baskets will be erected at Grimsby, Ont., by Arthur Hewson, care Grimsby Manufacturing Co.

Newcastle, N.B.—Falconer's carriage factory and Falconer & Allen's stock were destroyed by fire February 1. Some insurance was carried.

Calgary, Alta.—The woodworking plant of J. M. Bateson was burned down on Monday, Jan. 20. The loss, \$60,000, is covered by insurance.

Fredericton, N. B.—Aiken Brothers' lumber camp on the Keswick was destroyed by fire on Monday, Jan. 6, the loss being upwards of \$1,000.

St. Charles, Que.—N. Labrie's sawmill was recently destroyed by fire at a loss of about \$12,000, partly covered by insurance. Mr. Labrie will rebuild.

St. Mary's, Ont.—Daniel Baird, Station West, plans to erect an addition to his planing mill, for which new woodworking machinery will be required.

London, Ont.—Mr. R. C. Eckert, 434 Queen's Avenue, London, Ont., is interested in a syndicate which has purchased a site for a furniture factory here.

Quebec, Que.—Old buildings are being razed on the Louise Docks to make way for the new Harbor Commissioner buildings. The builders will be ready for steel in a month.

Grand Falls, N.B.—The Engineers of the Grand Falls Co. completed plans for immense pulp and paper mills at Grand Falls. These will be submitted to the directors at an early date.

Belladune, N.B.—The mill of the Saw Mills Owners Sales Co. has been burned out. It was a new winter mill, which had just been completed, and was fully equipped, including electric light.

Fredericton, N.B.—Messrs. D. Fraser & Sons have taken possession of the Scott Lumber Co.'s property, which they acquired in their recent \$150,000 timber lands purchase, and work has been started upon the improvements to be made at the Victoria Mills.

Toronto, Ont.—Fred W. Halls Paper Co., Ltd., has been incorporated in Ontario, with head office at Toronto, and capital stock of \$40,000, to carry on the business of manufacturing paper, etc.

Shawinigan Falls, Que.—The Belgo-Canadian Pulp Co. are adding to their electrical equipment, having purchased eleven Canadian General Electric motors, aggregating two hundred horsepower.

New Westminster, B.C.—A sawmill, box factory and shingle mill, costing \$75,000, will be erected here by Temple, Ronald Cliff and J. H. McDonald, late manager of the British Canadian Lumber Co.'s mills on Lulu Island.

Vancouver, B.C.—The British Overseas Trust Company, Limited, recently incorporated in British Columbia, includes among its various powers granted by charter the right to secure and develop timber limits, pulp or paper making works, sawmills, etc. The capital of the company is \$250,000.

St. John, N.B.—The city has sold to Mr. Frank H. Davis certain parts of the city's pulp mill at Mispec. The sale included two pumps, two lathes, one vertical drill, one planer, one shaper and one small engine, in addition to a number of other smaller articles. The price was \$15,250.

Sudbury, Ont.—J. B. Laberge & Sons will build a large planing mill and sash and door factory in the spring. The factory will be equipped with latest machinery, and will employ 40 hands to start. Mr. F. H. Aurie will be the factory manager.

Stratford, Ont.—Messrs. Chas. Farquharson and F. Gifford, of the Geo. McLagan Furniture Co., will on certain conditions build a \$30,000 factory for the manufacture of Davenport beds, upholstered furniture. It will be four storeys in height.

New Westminster, B.C.—The Royal City Mills plant of the B.C. Timber & Trading Co., has been purchased by Capt. C. H. DeBeek, former president of the Fernridge Lumber Co. He will operate there a shingle and cedar saw mill plant. Its capacity will be 150,000 shingles and about 15,000 feet of clear cedar a day.

Montreal, Que.—The factory of the Bass Fur Co. was recently burned, the loss being \$50,000. It will be rebuilt at once.

Toronto, Ont.—A factory, to cost \$100,000, for A. B. Ormsby & Co., is being erected by Wickett Bros. It is one of two storeys, 247 x 260, cement and brick foundation, brick and structural steel construction.

Toronto, Ont.—Mr. James Ryrie will erect a five-storey office and commercial building, costing \$250,000, at the corner of Yonge and Shuter Streets.

Moose Jaw, Sask.—The Metal Specialties, Ltd., will construct buildings, costing \$75,000, exclusive of machinery.

Edmonton.—It is reported that the Cockshutt Plow Co. is contemplating the erection of a new warehouse, to assist distribution in the West.

Vancouver, B.C.—The Dominion Construction Co. have secured the contract for the erection of a ten-storey office building for the Yorkshire Guarantee and Securities Corporation. The approximate cost is placed at \$250,000.

Vancouver, B.C.—The tender of Mr. C. F. Perry for the construction of new police headquarters has been accepted. His price is \$250,000.

Lethbridge, Alta.—The International Harvester Co., of America, will build a four-storey warehouse, costing over \$100,000. It will be large enough to accommodate 100 earloads of machinery.

Regina, Sask.—Plans are being prepared for the erection of Winter Fair buildings at a cost of \$134,000, 328 feet long by 190 feet wide. They will be heated throughout by steam.

Refrigeration

Westmount, Que.—The Ice Manufacturing Co., have been granted permission to build a plant on Bethune Street.

Toronto, Ont.—Tenders have been called for the 100-ton ice plant by the ice dealers of this city, the estimated cost of which, including the building, will be \$100,000.

Montreal, Que.—There is a renewed talk of a new skating and hockey arena with artificial ice. There is a scarcity of playing ice at present, and on this account some of the rinks charge exorbitant terms to some of the smaller hockey clubs.

Toronto, Ont.—The Ice Manufacturing Co., Ltd., have purchased a site in the north east section of the city, along the C.P.R. main line to Montreal, and will

Building Notes

Toronto, Ont.—The Zionist Societies will erect an institute at a cost of \$50,000.

Stratford, Ont.—A factory, costing \$15,000, will be built for the Stratford Mill Building Co.

build an ice factory of 200 tons daily capacity, and ice storage of 50,000 tons capacity. A smaller plant will be built in the east end of the city.

Toronto, Ont.—Construction will begin soon on the Toronto Municipal Abattoir, where facilities will be provided for private butchers, or meat dealers to do their slaughtering. There will be three buildings; the abattoir proper, a rendering plant, and a power house. Refrigerating machinery will be installed.

Marine

Ottawa, Ont.—The Government will spend large sums of money on harbor improvements at St. John, N.B.; Quebec, Trenton, Ont.; Toronto, Brighton, Ont.; Oshawa, and Port Credit.

Ottawa, Ont.—The Government will spend \$500,000 for waterway improvements at French River, and \$2,000,000 for the Welland Canal. The sum of \$250,000 is asked for a new ice-breaker steamer for the St. Lawrence, and \$145,000 for a fisheries patrol steamer for Lake Winnipeg.

Sault Ste. Marie, Ont.—The promoters of a dry dock have succeeded in financing the enterprise in England. Messrs. Pethwick Bros., Ltd., of Plymouth and London, have undertaken the work at a cost of \$1,000,000. Construction will commence April 30, 1913, and the dry dock must be completed by October 1, 1914.

Montreal, Que.—The Montreal Harbor Commission has awarded a contract for a 1,500,000 bushel addition to its elevator No. 1, to John S. Metcalf Co., Montreal. This will make the total capacity of this elevator 2,500,000 bushels; while elevator No. 2, recently completed by the same firm, has capacity for 2,600,000 bushels. The addition will be of reinforced concrete and steel, and will cost approximately \$700,000.

Tenders

Winnipeg, Man.—Tenders for the erection of a grey iron foundry building at this place were received until noon of February 8, 1913, at the offices of the Manitoba Bridge and Iron Works.

Woodstock, Ont.—Tenders will soon be called for the New Agricultural College so that work will be completed this season. The cost without equipment is estimated at \$30,000. Among the departments requiring machinery will be the forge, concrete laboratory, power house, and manual training department.

Sarnia, Ont.—Tenders will be received up to March 15 for waterworks construction. These include:—Furnishing cast-iron or steel water pipes and special castings; gate valves, flexible joints, expansion joints, etc.; furnishing and erecting pumping machinery and accessories; furnishing and erecting boilers.

Vancouver, B.C.—Tenders are invited for: 5,280 lin. ft. of 2-in. gal. iron pipe with unions; 5,280 lin. ft. of 4-in. No. 8 lapwelded or weldless steel pipe; 107,000 lin. ft. of 6-in No. 9 lapwelded or weldless steel pipe; 50,000 lin. ft. of 8-in. No. 7 lapwelded or weldless steel pipe. These should reach City Purchasing Agent, City Hall, before March 5.

Dalhousie, N.B.—Sealed tenders will be received by the Town Clerk until 8 p.m., Wednesday, March 5, 1913, for the following works:—

Contract B—Power house.

Contract G—Booster pump: (1) steam pump, (2) turbine pump.

Contract H—Two boilers.

Contract J—Electric light engines: (1) High speed steam engine, (2) Gas engine and gas producers, (3) Diesel oil engine, (4) Crude oil engine.

Contract K—Electrical equipment and distribution system.

Plans and specifications may be seen on and after February 10th at the office of the Chief Engineers, Mail Building, Toronto, or at Dalhousie, N.B. W. S. Montgomery, Mayor; Alex. J. Le Blanc, Town Clerk; Chipman & Power, Engineers.

Toronto, Ont.—Tenders will be received by registered post only, addressed to the Chairman of the Board of Control, City Hall, Toronto, up to noon on Tuesday, March 4th, 1913, for:

Concrete Mixers,
Grading Machines,
Tar Kettles,
Road Rollers, 3-wheel,
Road Roller, tandem,
Scarifiers,
Stone Crushing Outfit, complete (stationary.)
Centrifugal Pumps, portable, with boilers, mounted.
Boilers Mounted,
Hoisting Engines and Boilers,
Derricks,
Clams,
Buckets,
Excavating Machine, complete,
Diaphragm Pumps and Hose,
Inspection Rods.

Specification and tender form may be obtained upon application at the office of the Purchasing Section, Department of Works, City Hall, Toronto.

New Incorporations

Moose Jaw, Sask.—Moose Jaw Engineering Works, \$300,000.

St. John, N.B.—Canadian Motor Co., \$15,000—I. S. Houghton, W. W. Gerow, B. L. Gerow.

Granby, Que.—Macdonald Car Buffer Co., \$500,000. M. Alexander, P. C. Dwyer, D. B. Smith, Montreal.

Preston, Ont.—Cast Aluminum Ware Co., \$40,000—H. R. Schmiedendorf, Buffalo; A. Ochs, W. Stalhschmidt, Preston.

Westport, Ont.—Westport Woodworking Co., \$40,000—W. C. Whiteher, Westport; W. R. McGree, G. M. Dudley, Ottawa.

Sarnia, Ont.—Anker-Holth Separator Co., \$40,000—S. C. Anker-Holth, G. T. Benson, Port Huron; H. F. Holland, Sarnia.

Hamilton, Ont.—White Sewing Machine Company of Canada, \$40,000—C. Touby, Cleveland; C. Stewart, W. C. MacBrayne, Hamilton.

Vancouver, B.C.—Pacific Coast Cable Co., \$25,000. Dickie Creek (Lillooet) Power and Light Co., \$25,000. Booth Logging Co., \$100,000.

Palmer Rapids, Ont.—Hamilton Corundum Co., \$200,000. W. J. Hamilton, Flint; G. Hamilton, Mendon, Mich.; G. E. Foote, Kalamazoo, Mich.

Vancouver, B.C.—A company, headed by E. H. Heaps, is planning a new steamship service from Montreal to Vancouver, by way of Panama.

Kingston, Ont.—A new firm of engineers and contractors under the name of The Kingston Construction Co., has been formed, with George Wright, C.E., as general manager. They will make cement brick, concrete block, and artificial stone specials.

Winnipeg, Man.—The Lake Winnipeg Brick and Lumber Co. has been incorporated under the Manitoba Companies Act, with powers for the development of lands in the province, operating vessels, carrying on the business of a common carrier, the ownership of docks, wharves and terminal facilities.

Toronto, Ont.—Incorporations mentioned in The Ontario Gazette last week were:—National Gas Co., Ltd., Toronto, capital \$500,000; Queen City Pressed Brick Co., Ltd., Toronto, capital \$200,000; The Renfrew White Granite Co., Ltd., Ottawa, capital \$180,000; Ontario Stone Corporation, Ltd., Toronto, capital \$175,000; Trout Creek Gold Mines, Ltd., St. Catharines, capital \$150,000; Can-

adian Woodtile Co., Ltd., capital \$150,000.

Corbeil, Ltd., incorporated at Ottawa with \$1,000,000 capital, to carry on business as boot and shoe manufacturers at Montreal: Incorporators, Avila Corbeil, Emile Corbeil, Leonard Blais, Theophile Desrochers, and H. J. H. Morrier, all of Montreal.

Chambers, McQuigge & McCaffrey, Co., Ltd., incorporated at Ottawa as contractors, Toronto, with \$500,000 capital: Incorporators William Clark Chambers, Anson Spotton, Henry Leighton, Eunice Leighton, Irene Edmunds, all of the town of Harriston.

The Perkins Electric Co., Ltd., have been incorporated at Ottawa, capital \$50,000; to manufacture electrical machinery and supplies at Montreal: Incorporators, Frederick J. Parsons, Philip S. Fergusson, Walter R. Baillie, Geo. F. Perkins, Montreal, and Calvin Colborne Perkins, Mansonville, Que.

Sorel Iron Works, Ltd., incorporated at Ottawa with \$100,000 capital, to conduct an iron and steel foundry and machine and repair shop at Sorel, Que.: Incorporators Antonin Patrice Pontbriand, George W. Pontbriand, Henri M. Pontbriand, and J. I. Pontbriand, Come Damien Pontbriand, all of Sorel.

Amherst Pianos, Ltd., have been incorporated at Ottawa with a capital of \$500,000 to manufacture pianos and other instruments at Amherst, N.S.: Incorporators, Robert Harper Murray, John Lauchlin MacKinnon, Emily Hilton, Grace C. Griffin, and Wm. Martin McDonald, all of Halifax.

Missisquoi Marbles, Limited, incorporated at Ottawa, with \$1,000,000 capital, to work quarries, with offices at Philipsburg, Que.: Incorporators, Andrew Ross McMaster, of Westmount, Talbot Mercer Papineau, John Keery, Margaret Hartley, Montreal, and Gertrude H. Flawn, of Outremont.

Canadian Griscom-Russell Co., Ltd., incorporated at Ottawa, with \$50,000 capital, to carry on business as iron and brass founders and machinery manufacturers at Montreal: Incorporators, John Wilson Cook, K.C., Allan Angus Magee, Thomas J. Coonan, Thos. B. Gould, and Pearl Catherine Mahoney, all of Montreal.

Montreal, Que.—W. F. Myers Diamond Saw, Tooth & Tool Co., \$5,000; J. A. Mann, C. G. Mackinnon, T. B. Gould. Modern Joint of Montreal (founders), \$75,000. J. Galipeau, S. Langlais, T. Goulet. Perkins Electric Co., \$50,000. F. J. Parsons, P. S. Fergusson, W. R. Baillie. Canadian Griscom-Russell Co., \$50,000.

(iron founders), J. W. Cook, A. A. Magee, T. J. Coonan. American Engineering and Machinery Co., \$50,000. L. J. Loranger, J. A. Prudhomme, M. Loranger.

Macdonald Car Buffer, Ltd., incorporated at Ottawa with \$500,000 capital, to manufacture cars and car buffers and railway equipment of every kind: Incorporators Mauriee Alexander, Patrick Clarke Dwyer, Darley Burley Smith, Jean Gustave Mignault, all of Montreal, and Jennie Louise Lawrence, of Westmount.

Lake Erie & Quebec Transportation Co., Ltd., incorporated at Ottawa with \$400,000 capital, to sell and make machinery required in the construction of ships, at Montreal: Incorporators Francis George Bush, George Robert Drenman, Michael Joseph O'Brien, Herbert William Jackson, Gordon Francis MacNaughton, all of Montreal.

The Owen Sound Rolling Mills Co., Ltd., incorporated at Ottawa with \$500,000 capital to manufacture wrought iron and steel, nuts, bolts, pig iron, billets, etc., at Owen Sound, Ont.: Incorporators, Archibald Henry Macdonald, John Jacob Drew, Frederic Watt, Priscilla Jean Ryde, and Alice Beatrice Cabeldu, all of Guelph, Ont.

Toronto, Ont. — Goldsmith Brothers Smelting and Refining Co., \$40,000—H. L. Nussbaum, Chicago; J. G. Maycock, Cincinnati; E. F. Singer, Toronto. Bell-Field Manufacturing Co., \$40,000—J. H. Hunter, W. M. Cox, R. G. Roberts. Glenwood Natural Gas Co., \$750,000—H. Riley, W. B. Sturupp, J. F. MacGregor. Standard Bronze Co., \$40,000—C. S. McDonald, C. H. Wilson. Jarvis Oil and Gas Co., \$40,000—J. Gray, A. Gray, G. A. Jones. Clements Manufacturing Co., \$20,000—D. I. Grant, G. A. Urquhart, E. Eisinger. McLaren Lumber Co., \$1,250,000—R. C. LeVesconte, V. J. Callen, H. Dreamy. Dominion Traction and Lighting Co., \$12,500,000. W. A. J. Case, J. B. Taylor, C. G. Lynch.

Miscellaneous

Toronto, Ont.—The Simpson Avenue Methodist Church will build a two-storey school house, costing \$30,000.

Saskatoon, Sask.—The Winter Fair Board have asked the City Council for \$150,000 to build a Winter Fair building.

Lethbridge, Alta.—The Calgary-Coutts branch of the G. T. R. through this town will not be built in 1913, but the Regina-Lethbridge branch will be.

Stratford, Ont.—The B. F. Kastner Co. agree to erect a \$15,000 plant for the manufacture of leather mitts and gloves if the town will make certain concessions.

Toronto, Ont.—The Delaney & Pettit Co., Ltd., will erect a two-storey brick factory at 105 Jefferson Avenue, costing \$10,000.

Penetanguishene, Ont.—A by-law giving the town the right to loan \$25,000 to the Dominion Stove and Foundry Co., to enable it to extend its plant, has been passed.

Montreal, Que.—William Daly has been given the contract to complete the unfinished section of the Transcontinental between Levis and the New Brunswick line.

Chatham, Ont.—The ratepayers last week carried the Chatham Auto Wheel Co. industrial by-law, and now the company will build a factory costing 40,000 and employing 40 men.

Port Arthur, Ont.—The City Council is considering a proposal from a Northern Island pulp wood company for the establishment of a pulp and paper mill at a cost of \$750,000.

Chatham, Ont.—The Miramicho Foundry have started work on a passenger steamer for Cape Breton parties. It will be 60 feet long and 14 feet beam. It will be finished in May.

Toronto, Ont.—The warehouse of the Railway Equipment Company and the factory of the Bowman Range Company were burned out in a fire on Dundas Street, Monday night, February 10.

Saskatoon, Sask.—Sealed tenders, addressed to the City Commissioners, will be received up to twelve o'clock noon on Thursday, the 27th day of February, 1913, for one 1,000 lbs. electric service truck.

Fort William, Ont.—The capacity of the Seaman-Kent plant will be doubled this spring, additional buildings and equipment being required. Four additional kilns will be installed. Mr. J. E. Ockley is the loal manager.

Toronto, Ont.—Mr. W. R. Brock has bought the factory and land of the E. W. Gillett Co. at King and Duncan Streets, and it is reported he sold it to the Fancy Goods Co., of Canada. The building is worth 35,000.

Toronto, Ont.—Seventy-five new cars are to be turned out by the Toronto Railway Company this year. They will be of the most improved type. The style of the new cars will be of the same class as their latest make, with a few added modern conveniences.

Fraser Mills, B.C.—The Canadian Western Lumber Company are erecting a large cedar plant at a cost of \$350,000 to \$400,000 for the manufacture of sashes and doors. The new mill will have a capacity of 125,000 feet per day, and will employ 200 hands.

Berlin, Ont.—William Greene & Rome Co., Ltd., shirt and collar manufacturers, are erecting a factory building of four storeys. It is to be modern in every particular, 200 x 150, with separate power plant. It will be constructed of reinforced concrete, flat slab system, with round concrete columns, and equipped with five towers and sprinkler systems. Wm. Steele & Sons, Toronto, are the engineers and architects.

Vancouver, B.C.—Work will soon commence on the C.N.R. works at Port Mann, B.C. The buildings to be erected are as follows: Fifteen stalls of what will later be enlarged to a 42-stall roundhouse; a repair shop; coaling station; oil storage house and a general store house for train equipment. With the repair shop will be a complete foundry and blacksmith shop.

Windsor, Ont.—The Remington Arms Union Metallic Cartridge Company, of New York, are shortly to establish a big plant, which will enable the company to enter the Canadian field on a very extensive scale. The site of 100 acres purchased includes property on the south side of Tecumseh Road, extending along Howard Avenue from the tracks of the Canadian Pacific Railway. The company have awarded contracts for its first buildings to Windsor contractors. Construction work will be started at once, and it is expected that one building in which at least fifty men will be given employment will be ready in April. It has been decided to confine the operations to the manufacture of cartridges for the present, and a plant requiring several hundred employees will be completed in the near future. No powder will be manufactured in Windsor.

Obituary

R. H. Wolfe—Word has just been received of the death in Germany of R. H. Wolfe, former president of the Electro-Metals Co., of Welland. Mr. Wolfe has not been actively connected with the firm recently, and had been spending his time in his native land, where the body will be interred.

Mr. Robt. Woon, of the R. Woon & Co. machine works, Oshawa, Ont., died on Friday, January 24, after a very brief illness. He was born in Oshawa.

The deceased started with the Joseph Hall Manufacturing Co. in 1864, and when that concern failed he, with Mr. French, started the present works known as the R. Woon & Co. works, purchasing the patterns of the defunct firm.

Mr. Christian Kloepfer, ex-M.P., of Guelph, Ont., died on Sunday, February 9, from pneumonia. At the time of his death he was president of the C. Kloepfer Co., Ltd., wholesale carriage hardware, of Guelph and Toronto; of the Raymond Manufacturing Co., of Guelph; of the Dominion Linen Manufacturing Co., Ltd., of Guelph; of the Guelph Worsted Spinning Mills Co., Ltd., and of the Trusts and Capital Brewing Co., of Ottawa; vice-president of the Guelph Stove Co., Ltd., and of the Trusts and Guarantee Co., Toronto; director of the Spanish River Pulp and Paper Co., Ltd.; of the Dominion Permanent Loan Co.; of the Traders Bank before its amalgamation with the Royal Bank, and of the Commercial Travelers' Association.

Mr. Wm. Johnston Sproule, M.E. (McGill), died at his home at St. Lambert, Que., on Thursday, Feb. 6. He was connected with the Montreal Harbor Commissioners as assistant engineer for 30 years, but retired two years ago. He was born at Schomberg, Ont., and after receiving his elementary education at that place came to this city to take a science course in McGill. Shortly after graduating, he joined the Montreal Harbor Board staff. He was the first mayor of St. Lambert, and at the time of his death was a councillor of the town. Mr. Sproule was a member of the council of the Canadian Society of Civil Engineers.

Personal

T. F. Kelly, contract agent of the Cataract Power Company, has accepted a position at Dayton, Ohio.

Mr. Fox, resident of Minneapolis, but formerly of London, Eng., was made water works engineer of Calgary on January 27.

Mr. F. Ross Newman, resident manager in Toronto for the Canadian Fairbank Morse Co., Ltd., has gone to Europe for a well earned rest.

Mr. G. W. Smith, president of the Engineering Equipment and Supply Co., Montreal, entertained his staff at dinner on Thursday night, Feb. 6.

Mr. John E. Gow, of Kingston, district inspector of Inland Revenue, has been appointed inspector of bonded manufactories for the Dominion.

H. H. Wilson has been appointed Toronto Assistant-Inspector of Gas and

Electricity, and **E. Little** to a similar position at Fort William, by orders in Council.

Mr. P. H. Kemble is severing his connection with the Toronto Electric Light Co. Mr. Kemble has accepted the position of manager of the commercial department of the Union Gas and Electric Co., Cincinnati.

W. M. B. MacDonald, electrical superintendent of the Cape Breton Electric Co., was married in Montreal recently to Miss Hebden, the daughter of a Montreal banker. Mr. and Mrs. MacDonald will make their home in Sydney.

Mr. Allan A. McQueen, B.A.Sc., an honor graduate of the School of Practical Science, Toronto University, 1912, has just received the appointment of assistant power engineer of the city light and power system of Winnipeg. Mr. McQueen was at one time connected with the Toronto Hydro-Electric system.

E. J. Phillips, of Berlin, has been appointed manager of the Brockville light and water department, to succeed C. T. Wilkinson, who has retired to go into business. Mr. Phillips' salary will be \$2,500 per annum.

Calendars

The **Bawden Machine Co., Ltd.**, Toronto, are giving away what they rightly describe as a beautiful art calendar. It is a most graceful and charming feminine creation by Mr. Frank H. Desch, called 'In Meditation Sweet.' There is the same contrast of strong colors, the same graceful line, the same luxury of tone, the same beauty of modeling, the same exquisite coloring in the face and hair as in 'Lady Caprice,' by the same painter. The Bawden Machine Co. do themselves credit by issuing such a splendid calendar.

The **Cleveland Twist Drill Co.**, Cleveland, Ohio, have tried to make their calendar the most attractive and useful yet issued by a tool manufacturing concern. This will be sent, postpaid, to firms making a request, consistent with the limited edition. At the back of this calendar some valuable data is given regarding drills and taps, with miscellaneous tables. Among the latter will be found a list of decimal equivalents of drills in stock, cutting speeds, and drill lists for various taps.

Winnipeg, Man., seems to be the only city in Canada that has published a calendar and sent it broadcast over the Dominion. It is not a work of art by any means, but its statistics are arranged in such a manner that one sees immediately, for instance, that the output

of its factories has gone up from \$8,606,248 to \$39,400,600 in ten years, and that in the same period the bank clearings have risen from \$188,370,033 to \$1,500,000,000. Eight photographs give glimpses of the city's thoroughfares and parks.

Catalogues

The Vulcan Engineering Sales Co., Chicago, have issued a bound set of bulletins illustrating the several styles and sizes of Q.M.S. cold metal sawing machinery for which they are general sales agents.

Engineering Works of Canada, Ltd., Montreal, have sent us catalogue No. 1 dealing with the firm's line of open type induction motors, in sizes from 1/2 to 200 h.-p., built with squirrel cage or slip-ring rotor as desired. These motors are built to conform with the specifications of the A.I.E.E., and full details of their construction are given.

A 40-page catalogue, No. 90, entitled Lever Punches and Shears, has just been published by the Watson-Stillman Co., 50 Church Street, New York. Many types of punches and shears are illustrated and fully tabulated. A few screw punches and power-driven machines are also shown. Nine pages are devoted to fittings and repair parts. A free copy will be mailed on request.

The first thing that strikes one on looking at the calendar of the Canadian Tungsten Lamp Co., Ltd., Hamilton, Ont., is that the light from their lamp is intense and above the average. This effect is secured by the picture of a female figure, who holds in her right hand a "Nulite" lamp, and with her left hand shields her eyes from the glare. The background is of azure and green, which gives the white light of the Tungsten lamp a dazzling effect.

John M. Henderson & Co., Aberdeen, Scotland, favor us with three of their lists, dealing with Hand Derrick Cranes, Electric Jib Cranes and Steel Rope Suspension Bridges. Quite a number of photographs are used in the first of these, showing the uses to which hand derrick cranes may be applied. There are also a number of drawings. The other lists are not so extensive, but are quite as interesting, particularly that dealing with suspension bridges.

National Alloys, Ltd., Ilford, London, E., Eng., manufacturers and founders of high class engineering alloys, send us their latest list, with new information of use to those who employ alloys in their works. Although this booklet has a dis-

tinety catalogue appearance, it abounds with instruction, invaluable to foundrymen.

The Mahr Fuel Oil Burner Co., Minneapolis, Minn., in their latest pamphlet prove, apparently beyond doubt, that their burner gives a solid compact hot blast or flame, whereas the ordinary burner with a single combustion chamber, has a flame with a cold centre. They illustrate the effect by means of two drawings. Excellent photographs show the use to which the Mahr burner can be put in the machine shop or foundry, and the car department, for burning the paint off coaches.

Tallman Brass and Metal Co., Hamilton, Ont., have prepared a neat catalogue, showing exactly what they handle in the way of sheet brass, sheet copper, brass and copper tubing, brass rod—round, hexagon, square and rectangular, etc. It contains useful information, consisting of tables of weights and measures on brass and copper materials, which will be helpful in estimating. Attention is also called to their stock of Arctie metal, tin, lead, antimony, ferrules, nipples, unions, oakum, waste, clean outs, gas cocks, solder, metals, etc. Their slogan is: "Tallman's reputation is in the goods."

The Bath Grinder Co., Fitchburg, Mass., have favored us with a copy of their booklet—Useful Grinding Information. It has been prepared to show how certain operative features distinctive on their Universal Grinding Machine are used to advantage; to aid those confronted with grinding problems; and to assist those not familiar with grinding wheels to understand them. The first portion of this work is used to show how to grind cutters, and reamers. For each operation, an unusually instructive photograph is used. The second edition is devoted to Grinding Wheels and concludes with a page of "Don'ts," and a list of tables of interest to grinders.

Can. Westinghouse Co.—It is a pleasure to take up one of the neat bulletins issued by the Canadian Westinghouse Company, Ltd., Hamilton, Ont., dealing with any of their products. The covers are inviting, the paper is of first class quality, and the reading matter and illustrations always clear and interesting. This one, dealing with the serviceability of their motors, appeals to the farmer, the woodworker, the machinist, and the printer, giving examples of the use of the electric motor in their trades. Another bulletin on "How Westinghouse Small Motors Can Help You," contains suggestions for saving time and labor in homes, hotels, restaurants, offices, stores, shops, and on the farm. The same concern have sent us a work by Mr. F. E. Wynne, on Economics in Rail-

way Operation. Among the subjects treated are:—1. The discussion of field control for speed regulation, and 2. the matter treating of the correct application of motor equipment for a specific purpose. It is a reprint of paper read by Mr. Wynne before the Baltimore section of the American Institute of Electrical Engineers.

The Hawley Down Draft Furnace Co., Easton, Penn., are issuing a well printed catalogue, which clearly describes the various interesting features of the Hawley (Schwartz) metal melting furnaces. This catalogue is more especially devoted to the presentation of the advantages that the Schwartz furnace offers in the melting of small heats of iron and steel. It is in the melting of these small heats, for which the Bessemer and open-hearth furnaces are unsuitable, that the particular field of usefulness claimed for Hawley (Schwartz) furnace lies. This furnace is somewhat similar in outside appearance to a small Bessemer converter, the metal being first melted in a cupola, as in the Bessemer process. The subsequent conversion of the charge into steel, however, is carried out, as in the open hearth process, by the heat of a gas or oil flame playing over the surface of the bath of metal. Pouring is done either into ladles or directly into moulds. In cases where it is easier to move the furnace to the flasks than to bring the flasks to the furnace or to resort to ladles the company make a special type of furnace that can be readily disconnected and lifted off its housings by a crane and carried up and down the aisles of the pouring floor.

STEEL-COPPER TUBES.

STEEL for welded tubes has been made with small amounts of copper, in order to get the advantage of lower corrosion, but difficulty has been met with in the welding operation, and little progress has been made in consequence, although the alloy seems to have value. Copper has also been used to the extent of 0.25 and 0.30 per cent. in rail steel, and this metal is now in the track undergoing test.

The real reason why construction work has been suspended on the extension of the Grand Trunk Railway to Providence, R.I., has at last been discovered. It appears that the draftsmen who are plotting the surveys have not yet been able to spell Lake Chautaubungamaug. A Welsh draftsman has been cabled for.

The General Market Conditions and Tendencies

This Section Sets Forth the Views and Observations of Men Qualified to Judge the Outlook, and With Whom We Are in Close Touch Through Provincial Correspondents.

Toronto, Feb. 12.—The market for machinery in Toronto last week was just as dealers like it. There was a good even demand for all-round equipment, with no startling orders like that placed by the Ford Motor Co. some time ago. The tendency is towards small lots, but there are plenty of them. The biggest order came from the Moncton shops of the Transcontinental Railway, and dealers are eager to know where the larger order for the shops at Transeona is going. The demand is for a high-grade class of machine, because manufacturers are putting in machine tools with a view to increased production. One house reports an exceptional demand for Yale and Towne chain blocks.

The prospects for marine accessories for the fitting out of vessels for the coming season are rosier than usual, which goes to show that more attention is being given to higher grades of these commodities.

Sales have been large to the mining trade. The Great Western Iron and Chemical Co., of Prince Albert, Sask., have had representatives in Toronto recently buying heavily of machine tools and equipment for their new plant.

Judging from the number of new plants being installed in this province, buyers should be plentiful early in the spring. The National Tube Co.'s new plant at Fort William will be ready by the fall. The Brown Boggs Co. will soon erect an addition to their plant; an automobile factory is planned for Galt; tools are required by the Petrolea Valve Cap Co., who are rebuilding, and the Steel Co. of Canada, are extending. As will be seen from our industrial development section this week, the demand is country wide, and dealers should anticipate a rush on them before the spring has fully arrived.

Pig Iron.

Foundrymen who happen to have a stock of pig iron on hand are making the best possible use of it in the hope that before long the price of this commodity will go down. The purchasing agent for one of the largest concerns in this part of the Dominion says that he bought rather heavily in pig iron some time ago, and admits that if he were in need of more now he would wait, being convinced that a cut was coming. He visited Pittsburgh recently, where he found the same feeling to prevail.

The Toronto representative of an Ontario firm of pig iron manufacturers says that he would not be surprised to

see a drop take place in price, but did not think this would occur within six months. The demand is good, and most domestic furnaces are sold up for six months or more. The present year will see the world's production of pig iron reach its maximum.

Plates, Tubes, Structural Steel.

There is a heavy demand all over the country for plates, boiler tubes and structural steel. In Toronto and district the demand is coming from builders and bridge makers and agricultural implement concerns, all of whom have recently booked large orders. One steel house here has reduced the price of its steel bars and structural shapes for warehouse import—freight and duty to pay. These were respectively 2.05 and 2.15 cents a pound, and have been reduced to 1.95 and 2.05 cents. The cut resulted in a big increase in business.

Sheets, Plates, Bars.

Sheets, plates and bars are in demand, and the mills in the States are fully booked for this year in these lines. Bars are firm, and Canadian mills will be unable to ship in most lines under two or three months. The outlook suggests to buyers that the wisest policy would be to place their specifications early, and the same might be said regarding machine screws, nuts, bolts, wire, etc.

Metals.

The metal market is dull and unsettled. Practically no business is being done owing to the weakness existing. During the week the price of copper ingots dropped to a fraction below 16 cents in New York. Local dealers believe this to be the lowest possible. A reaction in this market was cabled from London on Monday, but it is believed that a rise, if it takes place now, will be very gradual. It is a year since copper was at such a low ebb. The same condition is to be found in the market for other metals and for old material. Those who have the latter on hand are holding for a rise.

Coke.

The price of coke remains unchanged. Coal has been rather difficult to obtain owing to the embargo on freight coming into the country over the Grand Trunk via Black Rock and Fort Erie, but a remedy for this congestion is in sight. Nearly a thousand cars of coal were held up at the border.

The report from Hamilton that the United States Steel Corporation had ac-

quired the Canada Steel and Wire Co., and that the plant would be removed to Sandwich, Ont., was confirmed by the Toronto representative of the Steel Corporation this week.

Trade Gossip

The Dominion Coal Co. are to install at their new coal docks at St. John, N.B., four vertical submerged tubular boilers, built for 150 lbs. working pressure by the International Engineering Works, Ltd.

The Montreal office of the International Engineering Works, Ltd., builders of Robb engines, boilers, etc., has been changed to No. 1001 Transportation Building, Montreal.

The Canadian Car and Foundry Co. have recently purchased for their new car shops at Fort William, Ont., a 375 h.-p Robb vertical two-crank compound engine for direct connection to a 250 kw. electric generator. This engine, the latest design of Robb vertical compound engines, is to operate at 360 revolutions per minute. It is being built by the International Engineering Works, Ltd., manufacturers of Robb engines, boilers, etc.

Refrigerating and Engineering, Ltd., Somerset Block, Winnipeg, Man., have been appointed agents for the Terry Steam Turbine Co., Hartford, Conn., for the territory represented by Manitoba, Alberta, and Saskatchewan. The Terry Company already have agents at Toronto and Montreal, Canada.

The Siemens Company of Canada, Ltd., have obtained the order for a 400 K.V.A. 200 r.p.m. 3-phase, 60 cycle, 2200 volt generator, with direct coupled exciter for the Corporation of Yorkton, Sask. As in the case of the previous generator supplied by them, the 400 K.V.A. machine just mentioned above will also be direct coupled to a Diesel engine manufactured by Mirrilees, Bickerton & Day of England, who are represented in the Dominion by the Canadian Boving Co., of Toronto.

PULP WOOD EXPORT.

CANADA'S exports of "mechanical, wet pulp of wood" to Great Britain during 1912 amounted to \$375,945, a decrease of \$432,225 in comparison with 1910, while those from Newfoundland indicate an increase of \$226,000, doubtless due to the increasing output of the Harmsworth mills. Great Britain's annual imports approximate \$5,000,000. Imports from Sweden have advanced annually from \$567,185 in 1907 to \$1,017,540 in 1911.

SELECTED MARKET QUOTATIONS

Being a record of prices current on raw and finished material entering into the manufacture of mechanical and general engineering products.

PIG IRON.

	Per Ton.	
Foundry No. 1 and 2, f.o.b., Midland	\$21	00
Gray Forge, Pittsburg	17	15
Lake Superior, charcoal, Chicago	18	00
	Mont'l. Tor'to.	
Canadian f'dry, No. 1	22	50
Canadian f'dry, No. 2	22	00
Middlesboro, No. 3 ...	21	00
Summerlee, No. 2 ...	24	00
Carron, special	23	50
Carron, soft	23	00
Cleveland, No. 1.....	22	00
Clarence, No. 3.....	22	50
Jarrow	25	50
Glengarnock	26	00
Radnor, charcoal iron.	33	75
Ferro Nickel pig iron (Soo)	25	00

BILLETS.

	Per Gross Ton.	
Bessemer billets, Pittsburgh ...	\$29	00
Open hearth billets, Pittsburgh.	30	00
Forging billets, Pittsburgh.....	36	00
Wire rods, Pittsburgh	30	00

FINISHED IRON AND STEEL.

Per pound to large buyers:

	Cents.
Common bar iron, f.o.b., Toronto..	2.10
Steel bars, f.o.b., Toronto.....	2.20
Bessemer rails, heavy, at mill....	1.25
Iron bars, Pittsburgh	1.70
Steel bars, Pittsburgh, future... ..	1.40
Steel bars, New York, future.....	1.56
Tank plates, Pittsburgh, future... ..	1.50
Tank plates, New York, future.....	1.61
Beams, Pittsburgh, future	1.50
Beams, New York, future.....	1.61
Angles, Pittsburgh, future	1.50
Angles, New York, future.....	1.61
Steel hoops, Pittsburgh	1.60

Toronto Warehouse f.o.b., Toronto.

	Cents.
Steel bars	2.35
Small shapes	2.50
Warehouse import, freight and duty to pay:	
Steel bars	1.95
Structural shapes	2.05
Plates	2.15

Freight, Pittsburgh to Toronto:
18 cents a carload; 21 cents less carload.

BOILER PLATES.

	Mont'l. Tor'to.	
Plates, ¼ to ½-in., 100 lbs.	\$2.40	\$2.40
Heads, per 100 lbs.	2.85	2.95
Tank plates, 3-16 in.	2.60	2.60
Tubes, per 100 ft., 1 inch	8.50	8.50
" " 1¼ in.	8.50	8.50
" " 1½ "	9.00	9.00
" " 1¾ "	9.00	9.00
" " 2 "	8.00	8.00
" " 2½ "	10.50	10.50
" " 3 "	11.50	11.50
" " 3¼ "	13.25	13.25
" " 3½ "	14.50	14.50
" " 4 "	18.00	18.00

BOLTS, NUTS AND SCREWS.

	Per cent.
Stove bolts	80 & 7½
Machine bolts, ¾ and less	65 & 5
Machine bolts, 7-16.....	57½
Blank bolts	57½
Bolt ends	57½
Machine screws, iron, brass	35 p e.
Nuts, square, all sizes.....	4c per lb off
Nuts, Hexagon, all sizes..	4¼ per lb off
Flat and round head.....	35 per cent.
Fillister head	25 per cent.
Iron rivets	60, 10, -0 off
Wood screws, flathead, bright	85, 10, 7½ p e off
Wood screws, flathead, brass	75, 10, 7½ p e off
Wood screws, flathead bronze	70, 10, 7½ p e off

WROUGHT IRON PIPE.

The following are Toronto jobbers' discounts on pipe. (Card weight) in effect from October 11th, 1912:

	Standard		Buttweld		Lapweld	
	Black	Gal.	Black	Gal.	Black	Gal.
¼ ¾ in.	63	48
½ in.	68	58
¾ to 1½	72½	62½
2 in.	72½	62½	69½	59½
2½ to 4 in. ..	72½	62½	71½	61½
4½ to 6 in.	72	62
7, 8, 10 in.	66½	54½

X Strong P. E.

¼, ¾, 1½ in. ..	64	54
¾ to 2 in.	68	58
2½ to 3 in.	68	58
3½ to 4 in.	65	55
4½ to 6 in.	63½	56½
7 to 8 in.	56½	46½

XX Strong P. E.

½ to 2 in.	43	33
2½ to 4 in.	43	33

IRON PIPE FITTINGS.

Canadian malleable, 40 per cent.; cast iron, 65; standard bushings, 70; headers, 60; flanged unions, 65; malleable bushings, 65; nipples, 75; malleable, lipped unions, 65.

COKE AND COAL.

Solvay Furnace Coke	\$5.25
Solvay Foundry Coke	6.50
Connellsville Furnace Coke	5.75
Connellsville Foundry Coke	6.25
Yough. Steam Lump Coal	3.75
Penn. Steam Lump Coal	3.63
Best Staek	2.95
All net ton f.o.b. Toronto.	

OLD MATERIAL.

Copper, light	\$13.25 to \$13.50
Copper, erucible	15.25 to 15.50
Copper, unere'bled, heavy	14.25 to 14.75
Copper wire, unere'bled.	14.50 to 14.75
No. 1 machine compos'n	12.50 to 12.75
No. 1 compo'n turnings	11.25 to 11.50
New brass ellings...	10.25 to 10.50
No. 1 brass turnings...	8.25 to 8.50
Heavy lead	3.75 to 3.90
Tea lead	3.50 to 3.60
Scrap zine	5.50 to 5.70
Pure tin foil	33.00 to 35.00
New York dealers purchasing prices.	

SMOOTH STEEL WIRE.

No. 6-9 gauge, \$2.35 base; No. 10 gauge, 6c extra; No. 11 gauge, 12 extra; No. 12 gauge, 20c extra; No. 13 gauge, 30c extra; No. 14 gauge, 40c extra; No. 15 gauge, 55c extra; No. 16 gauge, 70c extra. Add 60c for coppering and \$2 for tinning.

Extra net per 100 lb.—Spring wire; bright soft drawn, 15c; charcoal (extra quality), \$1.25.

METALS.

Prices per pound to largest buyers:

	Cents.
Lake copper, Toronto	\$16.50
Electrolytic copper, Toronto	16.50
Spelter, Toronto	6.10
Lead, Toronto	4.40
Tin, Toronto	50.50
Antimony, Hallet, Toronto	9.50
Aluminum	26.50

SHEETS.

	Mount'l.	Tor'to.
Sheets, black, No. 28....	\$2 80	\$3 00
Canada plates, ordinary, 52 sheets	2 90	3 00
Canada plates, all bright.	3 70	4 15
Apollo brand, 10¾ oz. (American)	4 30	4 20
Queen's Head, B.W.G....	4 45
Fleur-de-Lis, 28.....	4 15

NAILS AND SPIKES.

Standard steel wire nails, base	\$2 40
Cut nails	\$2 55	2 65
Miscellaneous wire nails..	75 per cent.	

Pressed spikes, 5/8 diam.,
100 lbs. 2 85

FINE STEEL WIRE.

Discount 25 per cent. List of extras.
In 100-lb. lots: No. 17, \$5; No. 18, \$5.50; No. 19, \$6; No. 20, \$6.65; No. 21, \$7; No. 22, \$7.30; No. 23, \$7.65; No. 24, \$8; No. 25, \$9; No. 26, \$9.50; No. 27, \$10; No. 28, \$11; No. 29, \$12; No. 30, \$13; No. 31, \$14; No. 32, \$15; No. 33, \$16; No. 34, \$17. Extras net. Tinned wire, Nos. 17-25, \$2; Nos. 26-31, \$4; Nos. 30-34, \$6. Coppered, 75c; oiling, 10c.

MISCELLANEOUS.

	Cents
Putty, 100 lb drums	\$2.70
Red dry lead, 560 lb. casks, per cwt.	6.25
Glue, French medal, per lb	0.10
Glue, 100 flake	0.11
White lead, ground in oil, No. 1 pure, 100 lbs.	8.40
Tarred slaters' paper, per roll...	0.95
Motor gasoline, single bbls., gal..	24½
Benzine, per gal.	23½
Pure turpentine	64
Linseed oil, raw	58
Linseed oil, boiled	61
Plaster of Paris, per bbl.	2.10
Plumbers' Oakum, per 100 lbs..	4.50
Pure Manila rope	17

PRELIMINARY ARRANGEMENTS FOR FOUNDRYMEN'S CONVENTION.

MR. James Wood, of the Sheffield Foundry Co., Chicago, was re-elected president of the Chicago Foundrymen's Club at the annual meeting held on January 11. L. C. Young, of the McDowell Foundry Co., Chicago Heights, was elected vice-president, and C. E. Hoyt, of the Lewis Institute, was re-elected secretary-treasurer. The following directors were also elected unanimously:—E. F. Axner, C. B. Carter, Henry Vrooman and J. G. Garrard. The nominating committee included A. M. Thompson, E. W. Smith, E. J. Welsh and William Pederson.

At a meeting of the board of directors held at the City Club on Thursday evening, January 16, many important plans were made for the ensuing year, including the appointment of standing committees. O. J. Abell was appointed chairman of the programme and education committee, and C. B. Carter, chairman of the entertainment committee.

In conjunction with the Association of Commerce, the Chicago Foundrymen's Club will have charge of the entertainment and other similar features connected with the Convention of the Allied Foundry Associations to be held in Chicago early in October.

CANADIAN TRADE OUTLOOK BRIGHT.

NOTWITHSTANDING the fact that the Canadian trade figures for 1912 constituted a record in the history of the Dominion, in view of the unparalleled activity which abounds in every industry, continued increases in Canadian trade may be expected in the immediate future. The annual report of the Deputy Minister of Trade and Commerce, just issued says:—

“In my last annual report I ventured the opinion that the large increase of \$76,232,634 shown in the total trade of Canada for the fiscal year 1911 over that of 1910 would be exceeded when the fiscal year 1912 closed. This prediction has been amply borne out by subsequent returns, the total imports and exports for the last fiscal year amounting to no less a sum than \$874,637,794, the largest volume of trade for any one year in the history of Canada. This was an increase over the year 1911 of \$105,193,889, or 13.6 per cent. It may be of interest to observe that the total trade of Canada for the last fiscal year was more than double the trade of only ten years ago. The increase in that time amounting to \$470,727,350 or 106.3 per cent.

NEW SYSTEM OF EXCITATION.

IN some recent hydro-electric developments, a new system of excitation is being used. One small motor-driven exciter set is put down for each generator unit. The exciter terminals are connected directly to the respective generator fields, and the capacity corresponds to that required by each generator. The motors of the various exciter sets are fed from one or two low voltage generators, driven by independent prime movers. Means are also provided so that the motors, if necessary, may be connected to the main bus, two separate sources thus being provided for their operation.

Mr. M. J. Keene, late of the Messrs. Pratt & Cady, of Boston, has taken charge of the valve and steam department of Messrs. Fairbanks, Morse & Co., Toronto.

Mr. Abram Wilbur Mace, the genial representative of Factory Products, Ltd., Toronto, is away on his honeymoon. His wife was Miss Edna Hayes, of Toronto.

U.S. IRON ORE PRODUCTION IN 1912.

FROM returns received up to January 24th last, the United States Geological Survey Department estimates that the total quantity of iron ore mined in the United States in 1912 was between 54,500,000 and 57,500,000 long tons. This quantity represents an increase of between 25 and 32 per cent. compared with the production in 1911, which aggregated 43,550,633 tons. It is, therefore, possible that the high record of iron ore output attained in 1910, viz., 56,889,734 long tons, may be slightly exceeded, although the returns received up to the date mentioned above, which are only approximate figures, are not quite sufficient to justify a definite comparison with the figures of 1910. In the Lake Superior district the production of iron ore apparently increased in slightly greater proportion than the average for the country at large, the total shipments having increased from 32,783,163 long tons in 1911 to nearly 48,750,000 tons in 1912, but there were very large stocks of ore; amounting to more than 11,000,000 tons at the mines in the district at the close of 1911, and these stocks may have been depleted in making the record shipments of 1912.

Production in the Birmingham district, Ala., was largely increased in 1912, especially through the large output of the Red Mountain group of Clinton hematite mines operated by the Tennessee Coal, Iron and Railroad Company. The production in Tennessee, North Carolina and Virginia apparently has not greatly increased, if at all, above that of 1911, probably because some of the blast furnaces in these States dependent on local ores were not in operation during the early part of 1912, and in the South the inactivity of blast furnaces is quickly reflected in the operation of the iron mines.

The Application of Liquid Fuel to Foundry Practice

By W. N. Best

The author of this paper incidentally remarks that it is possible to install equipment for burning oil, yet to simply burn at it, with the result, of course, that the highest satisfaction is not obtainable. The necessary requirements for success in oil burning, relative to the furnace and burners are clearly and simply set forth, while the utility of the field for different foundry processes, is shown to merit a wider scope of service and application.

IT has been stated that oil is a very slippery subject, and a great many methods have been employed to burn it, but in visiting various works one comes to the conclusion that the plant is either burning the oil or burning at it. There is a vast difference between the two, and we will consider some of the methods of atomizing the fuel, distributing the heat and securing the proper admission of air in order to reduce oxidization to the minimum and to control the temperature.

Origin and Production of Petroleum.

We will first consider the origin of petroleum. Scientists tell us it is the decomposition of vegetable matter and fish during the antediluvian ages. It was first discovered in the United States in 1859 at Titusville, Pa. During the first year only 2,000 barrels (42 gallons each) were produced. Since then in each succeeding year the production and demand has increased. Last year the United States alone produced 220,449,391 barrels, or 63.80 per cent. of the total world's production. Russia produced 66,183,691 barrels; Mexico, now ranked third, produced 14,051,643 barrels; while the Dutch East Indies came next with a production of 12,172,949 barrels.

There are two kinds of petroleum—one having a paraffine base, the other an asphaltum base. Either may be used as fuel in its crude state, but both are largely distilled in order to obtain the more volatile oils, such as gasoline, benzine, kerosene, etc. The residuum is called fuel oil, and is used in every class of service where coal, coke or gas can be used. It is proving a most superior fuel, because the operator has the fire under perfect control and can attain and maintain the heat required at all times. The ultimate analysis of this oil is as follows:

	%
Carbon	84.35
Hydrogen	11.33
Oxygen	2.82
Nitrogen60
Sulphur90

Gravity from 26 to 28 Baume.

Weight per gallon, 7.3 lbs.

Calorific value varies from 18,350 to 19,348 B.T.U. per lb.

Vaporizing point, 130 degs. Fahr.

Analysis of Beaumont (Texas) Oil.

	%
Carbon	84.60
Hydrogen	10.90
Sulphur	1.63
Oxygen	2.87
Gravity—21 Baume.	
Weight per gallon, 7.5 lbs.	
Calorific value, 19,060 B.T.U. per lb.	
Vaporizing point, 142 degs. Fahr.	

Analysis of California Oil.

	%
Carbon	81.52
Hydrogen	11.01
Sulphur55
Nitrogen	6.92
Oxygen	6.92
Gravity varies from 12 to 36 Baume.	
Weight per gallon, 7.6 lbs.	
Calorific value varies from 18,462 to 20,680 B.T.U. per lb.	
Vaporizing point, 230 degs. Fahr.	

Oil tar is a by-product of the water gas system used in numerous gas works. Coal tar, again, is a by-product of coke oven benches. When either of these tars is heated sufficiently to reduce its viscosity, it makes a most excellent fuel. Per pound, their calorific value is less than that of oil, but as they weigh from 9½ to 10 lbs. per gallon, while fuel only weighs 7.3 lbs. per gallon, their calorific value per gallon is greater than that of fuel oil. Oil tar has a calorific value of 16,970 B.T.U. per lb., or 161,200 B. T. U. per gallon, while that of coal tar is 16,260 B. T. U. per lb., or 162,600 B. T. U. per gallon.

Requirements for Burning Liquid Fuel.

In burning liquid fuel it is very essential to have good refractory material for the furnace; in fact, I always recommend nothing but A1 fire-brick of a quality which will stand an abrasive heat as well as having scarcely any perceptible expansion. For the average furnace it is necessary to use skilled labor; in other words, the man who constructs furnaces should be thoroughly trained to this art: consequently inferior brick is always a bill of expense and a disappointment, as it costs as much in labor as a brick that will last three times as long.

The burning of oil is a science. It requires brains rather than brawn, and there is a vast difference between the two. It is necessary to have a burner,

scientifically constructed, that will atomize any gravity of liquid fuel purchasable in the open market, no matter whether the oil be volatile or heavy; so heavy, in fact, that it must be heated to reduce its viscosity. Burners should be of such construction that they will not carbonize, but attain and maintain the required temperature at the will of the operator. They should also be such that when applied to a furnace, mold drying or core drying ovens, they will fit the fire chamber perfectly. Without cutting away the fire-brick, they must deliver the flame and heat evenly throughout the length and width of the fire chamber.

A great many people imagine that they can mash down a piece of pipe and make a burner, at the cost of 15 or 20 cents, which will atomize the oil. In 99 cases out of 100 it is a type of burner that they have seen in some other works, where they were simply burning at oil, not getting efficient service, although flame was everywhere present, especially upon the outside of the furnace or in the oven. One thing has not been considered, and this is the fact that such a burner is wasting from 12 to 20 per cent. in fuel. At the price of liquid fuel at the present time we should consider the price of the fuel rather than the price of the burner. Strange as it may seem, I have often seen the same size and type of burner placed in the side wall of a furnace having charging space 6 feet square as in an 18-inch furnace, and, after applying one burner, if that did not give sufficient fire, they applied others, until as many as five burners have been installed.

I have one blue print, which I can produce to-night, showing a furnace in which 26 burners were used. Oil was condemned simply because the man is not yet born who can successfully operate one-third that number of burners in any size furnace. The point which I desire to bring out is that, in applying liquid fuel to any equipment, it is essential to know, first, the capacity of the burner, and, second, it is necessary to have the burner filed to spread a blanket of flame which will cover the entire hearth or charging space of the furnace, or which will throw a narrow flame through a heat chamber without any impingement upon the walls of that chamber. The United States Govern-

ment has issued patents to thousands of American inventors upon burners of more or less merit, but all may be designated as three types—first, internal mixer; second, external atomizer; and third, mechanical.

Burner Features.

The great difficulty and abuse in the burning of liquid fuel is that many of the burners do not thoroughly atomize the oil. Second, they are of such construction that they carbonize. Third, the burners are not each carefully fitted for the type of furnace or oven to which they are to be applied. Fourth, they may operate fairly well with a light fuel, but when it comes to burn heavy fuel, it cannot be used because the burners will not thoroughly atomize heavy oil. I contend that a burner is not worthy of consideration unless it enables the operator to burn any gravity of liquid fuel purchaseable in the open market, for no manufacturer should be limited to the purchase of one particular kind of fuel. A burner wherein the base of the fuel carbonizes over the fuel passage is absolutely worthless. A burner should be of such construction that it can be filed to make a long narrow flame or a broad flat shape flame, and each burner should be thoroughly tested, so that when it leaves the shop where it is made the manufacturer knows that it will fulfill the requirements for which it is being furnished. A burner having the oil orifice below the atomizer orifice and independent of the same renders the most efficient service, because of there being no liability of the oil solidifying or carbonizing over the slot at the nose of the burner. A combustion chamber of adequate form and proportions for the uniting of the air requisite for perfect combustion, with the atomized fuel before it reaches the furnace proper, should be used on every furnace. This prevents the oxidization of the metal charged in the furnace, and also aids in forming a blanket of flame to cover the entire charging space; thus insuring, with the aid of the burner, the even distribution of the flame and heat.

Value of Liquid Fuel.

Liquid fuel is especially valuable in the equipment of air furnaces. First, for the reason that it makes a superior grade of metal, and second, you can produce the same kind of metal to-morrow, a week, a month, or a year from now as you can to-day. Furthermore, the various alloys are thoroughly mixed, and, whereas in some cases the fuel costs more than cupola practice, the better quality of metal offsets any difference in this direction. This style of furnace can also be used to a very good advantage in making semi-steel, the castings

of which are especially adapted for automobile parts and wagon construction.

Iron and steel is more valuable if it is heat-treated, and in order to do this a very accurate temperature is required. Liquid fuel is ideal for this purpose. We are to-day releasing the strain from even cast iron castings. This is rather an intricate service, as it requires a very even distribution of heat, for otherwise the process would result in the cracking of the castings.

In brass melting furnaces in brass foundries oil, if properly installed, is the ideal fuel. An air furnace is used to reduce the old brass by burning out the zinc so that it can be run into ingots which the metallurgist can test, mark and place in piles, so that they can be charged into the crucibles in the furnace to be melted into castings. This type of furnace is very useful in large works. During years past many manufacturers have drifted away from the use of crucibles melting their brass in direct-fired furnaces, but as metallurgists are now prominent in nearly all plants, the manufacturers are fast returning again to the making of brass in crucibles. In a few more years crucibles will be used exclusively in the making of brass castings. It is, therefore, important to melt the brass as cheaply as possible. Oil is ideal for this purpose, whether in a one-pot furnace or a furnace wherein a number of crucibles are charged. Only one burner is required for operating a multiple crucible furnace for melting brass or other alloys.

In mold drying, core drying or japanning ovens there is no fuel that can compare with liquid fuel, because you can get an even distribution of heat throughout the entire length and width of the ovens. It is important to cut out the use of stacks on such equipments, but the moisture should be permitted to pass out of the top of the oven. By this method a great saving is effected in the construction of the oven. Where small ovens are used for core drying, etc., one burner to five or six ovens, of say 6 ft. square, renders better service than a single burner to an oven. Both cores and molds can be dried much quicker by the use of this fuel than with coal or coke, simple because you get an even distribution of heat, and not a localized heat.

Oil Supply And Demand.

While the production of oil has increased the demand has also increased. With the increase in its price we should give greater attention to securing the highest possible efficiency from every drop of fuel. For comparison, the

analysis of one of the best coals may be of service. It is as follows:

	%
Carbon	82.26
Hydrogen	3.89
Oxygen	4.12
Nitrogen64
Sulphur49
Ash	8.60

Calorific value per lb., 15,391 B. T. U.

The average of good coals has a calorific value of 14,200 B. T. U. per lb.

—From a paper read before the Philadelphia Foundrymen's Association.



MANUFACTURE OF LOCOMOTIVE SUPERHEATER TUBES.

By J. P. Watson.

OF the new locomotives constructed in Canada during the past twelve months, at least 75 per cent. are equipped with a superheater of some kind, the majority making use of the Vaughan-Horsey form. The superheater units of this type are made of seamless steel tubing, 1 1/4 in. outside diameter and 15-16 in. inside diameter. The process of finishing these tubes, ready for the locomotive, as practised at the Montreal shops of the Canadian Pacific Railway is herewith described.

The tubes are obtained chiefly from Belgium, and come in ordered lengths with plain ends as shown at (A), Fig. 1. The first step is to upset one end to form the collar seen at (B), this being done with ordinary upsetting dies in an Ajax forging machine in the blacksmith shop.



FIG. 2.—MANUFACTURE OF SUPERHEATER TUBES.

From here the tubes go to the pipe shop for the remaining operations. As the finished tube requires a short right angle bend—see (D), Fig. 1,—provision has to be made to prevent flattening dur-

ing the bending operation. For this purpose the small iron plug seen at (C) is hammered into the end of the tube. The latter is then stood on end beside an elevated platform, and one of the two men who bend these tubes, pours sufficient dry sand through a funnel to fill

the third section of the die, completing the bending of the tube into the shape shown at (D)—Fig. 1. When the air is released from the main cylinder, this third die automatically rises, its lever being counter-weighted. The tube is released by letting the air off the brake

the shop and rendering the sand available for further use.

Each tube has now to be widened at the mouth, as seen at (D). For this purpose it is reheated and again placed under the press, where it is gripped by a pair of dies made to hold the open end up, instead of down as before. The vertical ram then pushes a punch into the opening, forcing it out to the full size at the mouth and giving the correct shape to the collar on the end.

Milling the Collar.

The next operation is the milling of the collars to exact standard size. For this purpose the tubes go to a machine arranged similarly to a small lathe having a cutter centrally located on the headstock. In place of a tailstock there is a revolving chuck which grips the tube end eccentrically and feeds it around the rotating cutter, finishing the collar on the face, rim and back.

All that now remains to do is to cut the tube to the length required. A bench is arranged with a stop at one end, against which the bent end of the tube is placed. At the other end of the bench is fastened a metal plate graduated to the several standard lengths used, so that each tube can be marked to length at a glance and immediately cut off in an ordinary pipe cutting machine.

Two tubes are next threaded and screwed into a cast steel return bend at $1\frac{3}{4}$ -in. centres. They are then tested under hydraulic pressure and, if found tight, form one completed unit ready for delivery to the erecting shop.

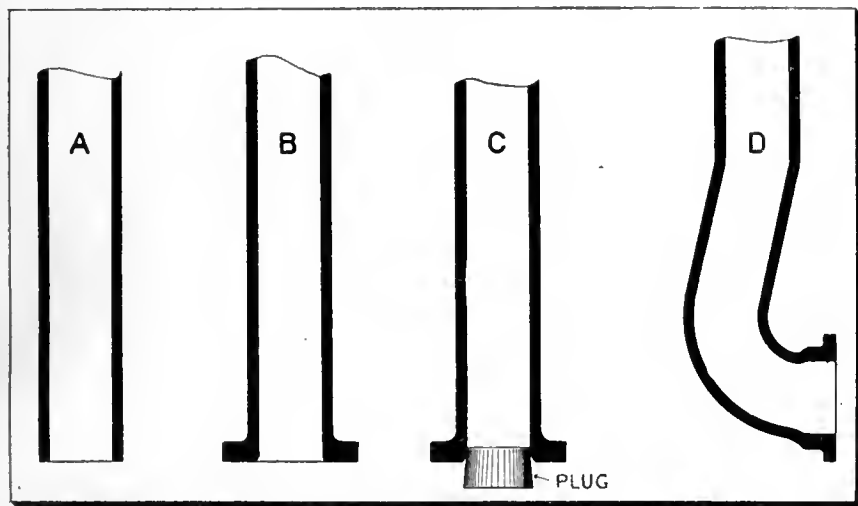

FIG. 1. MANUFACTURE OF SUPERHEATER TUBES.

the tube for about twelve inches from the bottom. The other man, in the meantime, lightly raps the tube with a hammer to make the sand settle compactly. After a batch of tubes is made ready in this way, they pass to an oil furnace, where the plugged ends are brought to a red heat.

The final bending is done under the 15-ton pneumatic press seen in Fig. 2. This is similar to those commonly used in railway shops for pressing in rod bushings. The main cylinder (E) stands vertically, and is supported on four turned columns, while mounted on the left hand side of the base plate is a 14-in. x 10-in. driving brake cylinder (F). The push rod of the latter carries a cast iron block fitted with an inserted hardened steel piece to form a die. A similar stationary block carries the other half of the die and forms a stop for the moving piece. These dies, when closed at the bottom, are open by the full width of a tube at the top. A third piece, fitting between the other two, carries the impression of the top half of the tube and is fulcrumed on the other two dies.

Bending the Tubes.

As a tube is withdrawn from the furnace, one of the men seizes the heated end with a pair of tongs and bends it through an angle of about 45 degrees. The other workman immediately inserts the collar of the tube in the dies under the press and admits air into the horizontal brake cylinder, thus securely clamping the tube. He then turns air into the vertical (main) cylinder, the descending ram of which forces down

cylinder. The iron plug usually falls out on releasing the dies, or is knocked out by tapping against the trestle on which the tubes are piled. Meanwhile the dies are blown free from scale and dirt ready for the next tube. When a batch of tubes have been bent, they are next cleared of sand by compressed air. The sand is blown into a small portable collector tank, thus keeping down dust in

High Power Milling Features and Developments

By H. Pearman*

Developments in machine tools are constantly in the direction of lower production costs which involve both the machine and the operator, since the two form the manufacturing unit. Increased output is gained by increasing the power and efficiency of the machine and simplifying the work of the operator.

HIGH-POWER millers are understood to indicate machines embodying the requirements for heavy cutting with coarse feeds; the term is not truly descriptive, since it does not refer to the power available at the spindle nose, and the user is more interested in what he obtains at that point than in what can actually be fed into the machine. It must be admitted that it is better if a given cut can be taken with a minimum of power beyond that required for the actual cut, since the excess must go towards wear out of the machine.—

Power Required to Feed.

Next in importance to power at the cutter, perhaps, is power required to

feed, a mechanism which often is a large absorber. It is obvious, therefore, that large driving pulleys, wide belts, increased gear ratios, etc., do not necessarily indicate high power at the business end of the machine. Although the miller may be an efficient power transmitter, and no less so than other machines, its metal removing capacity per horse-power minute is much below that of the lathe or planer, and except for the miller's many advantages in other ways, it certainly could not compete with many other tools.

Wider Scope for the Miller.

This disadvantage has been somewhat removed by the high-power miller, and

*In Machine Tool Engineer.

the field for milling has been largely widened, as, with its greater capacity, combination of movements, and ease of control, a large amount of work can be handled which previously fell to the planer, slotter, facing lathe etc. Where repetition work is dealt with, the capacity of jigs and fixtures is increased and multiple gangs of cutters can be mounted, also heavier work is mounted in jigs than was formerly possible, so that the possibilities of economy are now much greater, even on work which previously could be done cheaper otherwise than by milling.

The question of relative costs is important in considering different methods, and a factor often overlooked in making comparisons is the effect of the grade of finish obtained. Assuming other things to be equal, if a milled surface means less labor in fitting or other subsequent operations, then economy is evident; unfortunately, comparisons are seldom carried beyond the question of price per piece off the machine.

To get the best results attention can profitably be paid to the material to be machined. Cast iron should be annealed, and if this is done, a harder grade of iron can be used, resulting in stronger, closer, and more easily machined castings; also pickling the castings will show a very marked result on the life of cutters. These remarks apply with special force to high-power milling. The present high-power millers are undoubtedly built a little more scientifically than some of their predecessors, and we do not find the discrepancies between various makes. The basis upon which these machines are built is primarily a given metal removing capacity, from which are deduced the requirements to give necessary rigidity and strength to the various mechanisms.

Further requirements are ease of control and mechanical efficiency; the former is especially important, as the necessity for more intense work on the part of the operator must tend to lower the efficiency of the manufacturing unit.

Efficiency of Machines.

There is a great difference in the efficiency of machines of different makes, and the fact is important since the less efficient machines — although they have equal cutting capacity — absorb an excess of power which is constantly wearing out the machine.

A few points to look for in an efficient machine of this type are:—Absence of combined bending and torsion in shafts; absence of torsion in shafts subject to heavy loads; moderate gear and shaft speeds; minimum number of gears in action, no gears rotating which are not actually required for transmission; number bearing solidly clamped and not

simply hung on a pin or hook; driving shaft relieved of belt pull. Supplementing these, there are, of course, considerations as to the combinations for the various bearings, i.e., both character and size, in order that the original accuracy may be maintained.

Forced lubrication is advocated by some makers, but it must be conceded that the milling machine is hardly a mechanism on which this can properly be employed, as the exclusion of foreign matter from the oil is practically impossible.

As already observed, power consumption is not of vital importance, but the miller would be appreciated more if its consumption could be brought to the level of, say, the lathe. These present-day machines are, however, so efficient that there is really little margin for material improvement, so that any substantial increase of efficiency must be effected through the tools. It is an acknowledged fact that better results are obtained from cutters with increased tooth space and depth; this lowers the power consumption, permits more work for one sharpening, and increases the number of possible sharpenings.

Chip and Chip Space.

The proportion between chip and chip space is an actual limiting condition, for immediately the amount of metal removed per tooth is sufficient to fill the chip space, enormous stress is thrown on both cutter and machine. This is very evident in gangs of cutters which have been in use some time and the chip space much reduced. With high-power millers the cutter details become of extreme importance, and many have a decided influence on the output of the machines.

There is no ground for the belief that finish can only be obtained with cutter teeth closely spaced. The grade of finish may be expressed as the distance between successive marks on the work, and these are revolution marks and not tooth marks. They are due to the cutter not being absolutely concentric, owing to minute errors, such as its being easy on the arbor, etc. On a first-class machine these errors are individually negligible, yet the accumulation may be sufficient to mark the work, and, of course, these marks need only be a fractional part of a thousandth of an inch to be plainly visible. As they are caused by conditions which recur once for every revolution of the cutter it is obvious that the tooth spacing has no effect on the distance between them.

Milling Cutter Comparisons.

A few comparisons between the standard and high-power milling cutters may be of interest.

A 2-inch diameter taper shank ordin-

ary end mill has approximately three times the number of teeth as the high-power cutter of equal size. This means that the cutting action of the latter is remarkably free, as shown by the following test:—A 2-inch end mill milled a slot 1 1-16-inch deep in a solid block of cast iron at a rate of feed of 6 inches per minute. The block was clamped to the machine table and the knee fed upward, under which conditions the chips did not free themselves from the cutter, but were carried round and ground up, the cutter cutting over half its circumference. These conditions were about as difficult as possible, but there were no signs of choking, and the power consumption was no higher than it would be with a spiral mill under ordinary conditions.

The same cutter would remove from the end of a casting a section 1½ inches wide by 1½ inches deep at a feed of 11 inches per minute. In the case of the spiral mill a 3½-inch ordinary cutter would have about twenty-five teeth, while a high-power cutter of similar size would have nine teeth, corresponding to a pitch of about 1¼ inches; this gives a chip space four times that of the ordinary cutter. Stiffer arbors are necessary for these machines and cutters; a 3½-inch cutter would require a 1½-inch or, better still, a 1¾-inch arbor.

Chip Breaker Feature.

An important point in this type of cutter is the form of chip breaker, by which duplicate cutters—one nicked and one plain—are obviated. The form of nick previously used provided rake on one side only, whilst the other side had a negative rake, resulting in a scratched work surface. To overcome this trouble, the chip breaker is now formed so that rake is provided on both sides of the nick, resulting in an equally good surface as that produced by a plain cutter.

The Helical Mill.

Another type of cutter developed largely since the advent of the high-power machines is the helical mill. The distinguishing feature is that it pushes the chip off in the direction of the axis of the cutter or at right angles to the feed. The power consumption for steel is extremely low; a roughing cut in steel requires only about one-third the power of an old style spiral mill.

Another feature of this cutter is the entire absence of spring in the arbor when cutting steel; it is possible to take a finishing cut, then to return the work under the revolving cutter without producing a mark. With a single cutter of reasonable width, end pressure is not found to be a disturbing element, but usually for widths beyond about 6 inches, the cutter is made in two sections, right and left hand, interlocking.

Insulation in Refrigerating Plant and Power House

By R. Campbell

The subject of thermal insulation is one of the most important to be considered in connection with the efficient operation of a refrigerating plant, and is of hardly less importance in a steam plant. This article is written by a refrigeration expert, and will therefore prove interesting and instructive. It will be followed in a future issue by a paper on the insulation of boilers and steam pipes.

THE subject of insulation is one which has had liberal treatment at the hands of technical writers. The articles, however, which have appeared on this topic have been treated from the standpoint of the manufacturer of some insulating material either in a manner too technical for the average engineer or owner, or they were written a few years ago and are therefore now obsolete.

Cold storage construction and insulation have been completely revolutionized during the past decade. The old air space construction is gone for good and also the method of using a packing material between wood construction. This was absolutely necessary for several reasons, chief among them being the fire risks attached to air space construction, the rapidity with which it deteriorates, the increased space occupied, and the ever increasing cost of lumber.

Economy of Good Insulation.

Pipe insulation seldom receives the amount of attention which it deserves. It is generally overlooked until the plant is ready for operation, the result being that it is hastily collected, and applied; and the appropriation for the equipment of the plant being in all probability exhausted, the cheapest material obtainable is often used.

It is now generally recognized that a good pipe covering, properly applied, will return its entire cost within one year from its application. A cheap and less efficient insulation will no doubt also return the outlay on it in a similar period, but at the end of this time it will probably be found that the good insulation is preventing double the amount of loss as the inferior one, and this from year to year during all the succeeding years of operation. The result is that each year the owner who has installed the inferior insulation has a positive loss amounting to at least half the initial cost of the good insulation. This illustrates the folly of endeavoring to save money by using cheap insulation. Is it a wonder then that owners and their engineers are now making provision in their initial estimates of capital expenditure for efficient insulation, and are seeking for reliable data on this subject.

It is the purpose of this paper to discuss the materials and methods of insulation in a manner which should prove

of interest and instruction to those who are seeking impartial information on the subject. The matter will be treated under four heads, not only to make reference easier but because under each head, although the governing principle is the same, the materials used and methods of erection are altogether different. The divisions of the subject are as follows:—

1. Cold storage rooms.
2. Piping and tanks containing low temperatures.

Cold Storage Rooms.

The insulation of the cold storage building is probably the most expensive part of the plant, not alone in its initial cost but also, providing the work is not properly done in the power expended in making up for the loss incurred by poor insulation. It is therefore the part of wisdom for those who are building to make themselves familiar with the materials and methods of erection which have been proved satisfactory.

Corkboard or sheet cork is now al-

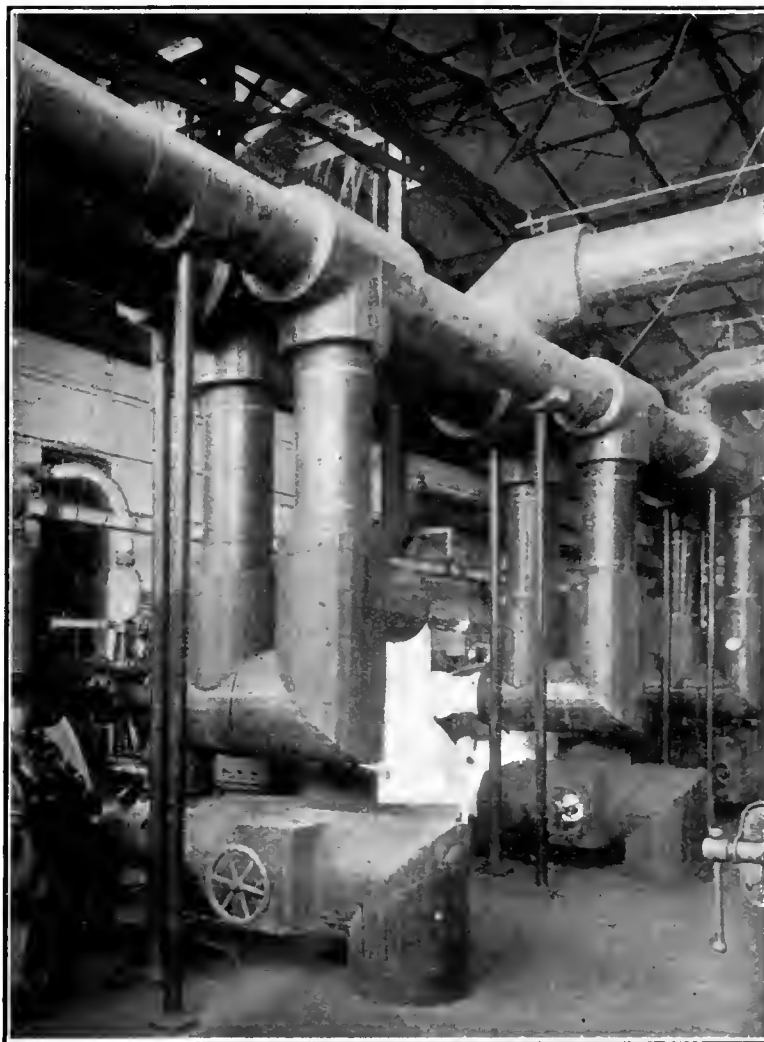

FIG. 1. CORK COVERING ON FLANGED BRINE PIPING AT STEEL CO. OF CANADA REFRIGERATING PLANT, HAMILTON, ONT. THE 8 IN. X 12 IN. SUCTION HEADERS ARE UNDER THE FLOOR.

3. Steam piping, boilers and heated surfaces generally.
4. Outside piping, underground and overhead.

most exclusively used for cold storage insulation. It is made from the waste material produced in the manufacture of cork articles and also from the lower

grades of the cork-bark. This is crushed into granulated form, compressed in molds, baked and trimmed to the desired size.

About three years ago the patents on the process of manufacturing sheet cork expired, with the result that several companies are now manufacturing a good article and the price has come down to a point which makes it one of the few materials worth considering for cold storage work. It has proved its efficiency beyond question and it is now very widely used.

The owner should see that he gets material made from pure, sound stock, compressed and baked to the proper degree, and that it is erected under the supervision of some one who has had plenty of experience at this class of work. The vital parts of the work will be all hidden on completion, hence the necessity for conscientious and experienced workmanship all the way through. Corkboard is not proof against moisture penetrating into the spaces between the particles, it is therefore necessary to have an impervious surface on both sides of the insulation and especially on the outside, because insulating ma-

duced the air pressure is also reduced, causing a partial vacuum into which the surrounding warm air endeavors to flow. Warm air generally carries moisture

ferent ways, but preferably by a Portland cement plaster finish applied directly to the cork, which should be scored to receive the plaster, or by a



FIG. 3. A DIFFICULT PIECE OF PIPE COVERING. CORK COVERING ON 8 IN. X 12 IN. FLANGED BRINE PIPING.

which would thus be deposited in the insulation, providing it can penetrate the surface, thereby decreasing its value and in time making it worthless. For this reason an impervious surface is required

coating of good bitumen. This is the chief point to be noted in the erection, whether it is on the walls, floors or ceilings. The methods of fastening will depend altogether on the conditions to be met, and each job must be considered by itself to give the best results.

Insulation Should be Embraced in Original Design.

In new buildings the insulation is generally left out of consideration until the framework of the building is completed. This is a great mistake. The insulation should be worked in with the general design and in some cases put in position with the framework of the building. A great saving can often be effected in this manner. The proper laying out of the room is another item on which economical results depend. Low temperature rooms in basements should be avoided on account of the danger of freezing the earth under the foundations. If moisture is present there is a possibility of heaving the building. This has frequently occurred with disastrous results.

The minimum thicknesses of sheet cork for the different temperatures to be carried are as follows:—

10 to 5 deg. F.	6 inches
5 to 15 deg. F.	5 "
15 to 30 deg. F.	4 "
30 to 45 deg. F.	3 "
45 to 60 deg. F.	2 "

Of course this will be governed to a great extent by local conditions, the construction and arrangement of the building, etc.

Sheet cork made by mixing granulated cork with some form of asphalt binders should not be used for cold storage work. Its cheaper price does not offset its lower efficiency as compared with pure sheet cork. Manufac-



FIG. 2. VIEW SHOWING TWO VERTICAL BRINE COOLERS (SHELL TYPE), INSULATED WITH CORK LAGGING. TOP AND BOTTOM BOXED IN AND FILLED WITH GRANULATED CORK, ALSO SHOWING 8 IN. X 12 IN. BRINE RISERS.

terials depend for their value on the minute air spaces which they contain. When the temperature of these is re-

duced and this is the secret of efficient insulation for low temperatures.

This surface can be obtained in dif-

turers make this grade to use up the trimmings of the pure sheets. The only place where it should be considered is on the floor of a comparatively high temperature room, where there is an excessive amount of water present.

Brine Ammonia Piping, Etc.

Brine circulating pipes and gas lines in connection with refrigerating plants, when these are outside of the space which they are to cool, brine coolers, brine storage tanks, and ice-making tanks, require to be insulated in order to maintain the low temperature within and also to prevent the "dripping" which occurs when the circulation ceases. This class of covering is the most difficult which confronts the engineer. The materials and methods employed are entirely different from those used on steam work. In the latter it is the material that counts; the manner of application in ordinary cases is not im-

versed. The best materials obtainable are of little value unless carefully applied, and it is imperative that the finished surface be quite impervious to air and moisture in order to prevent the inrush of warm air into the insulation, as explained under the paragraph above on cold storage rooms.

It is also important that sufficient space be provided around the piping to be covered. At least three inches should be allowed, and where flanges are used, this same distance should be provided outside the flange. Where two brine pipes run alongside they should be at least 8 inches apart. Few erect-ors give sufficient attention to this point. It should be remembered that the covering cannot be applied satisfactorily when the plant is in operation.

Hair Felt Covering.

The suitable insulating materials available are few. Theoretically hair

users still specify it and will no doubt continue to do so until there is some competition in the manufacture of a more suitable covering.

For covering pipes two layers of one-inch air felt are required for temperatures down to 15 deg. F. and below this three layers should be applied. Each layer must be tightly wrapped on the pipe with strong twine, bound spirally one half inch apart. Between each layer of felt two layers of tarred roofing felt should be applied, with joints broken and cemented between the layers with pitch or asphalt. The outside finish should consist of a wrapping of factory cotton bound on spirally and thoroughly coated with asphalt, then a layer of heavy building paper and finally a canvas jacket of 7 oz. duck sewn on. This may be painted with oils to any color desired. The heavy paper makes a uniform surface and prevents the asphalt showing through and disfiguring the jacket.

The fittings are done in the same manner, but not until the straight runs are finished. The covering on the straight runs should stop three inches away from each fitting and hanger and the ends should be sealed up tight with cotton and asphalt before the fittings are commenced. By attending carefully to this latter point the piping may be taken apart if necessary without destroying the covering on the straight runs of pipe.

Cork Covering.

Sectional cork covering as manufactured by the Armstrong Cork Company at Camden, N.J., is an efficient covering, but must be carefully applied so that all joints are perfectly tight. This is best accomplished by applying a liberal quantity of the cement provided and wiring on tightly so that the cement will ooze out of the joint for its entire length, giving particular attention to the end joints. It will sometimes be necessary to periodically paint the wires to prevent rusting. Where skilled help is not available and in difficult positions this covering should be used. It should be approximately three inches thick for ordinary cold storage work and thicker where conditions are severe, as over boilers and passing through warm rooms. Hangers should be made to go round outside the covering and on the larger sizes a protection of sheet iron should be provided on the under side.

The accompanying illustrations show examples of cork covering on large brine piping. The covering on piping over 8 inches in diameter and also on the larger fittings required to be built up to lagging, as will be seen in illustrations.

Cold Water Pipe Coverings.

For ordinary cold water lines the conditions are similar to the brine, but not

felt is the most efficient insulation in a commercial form, and good work has been done with it. Some of the largest

portant except where a neat finish is required.

With brine work the position is re-

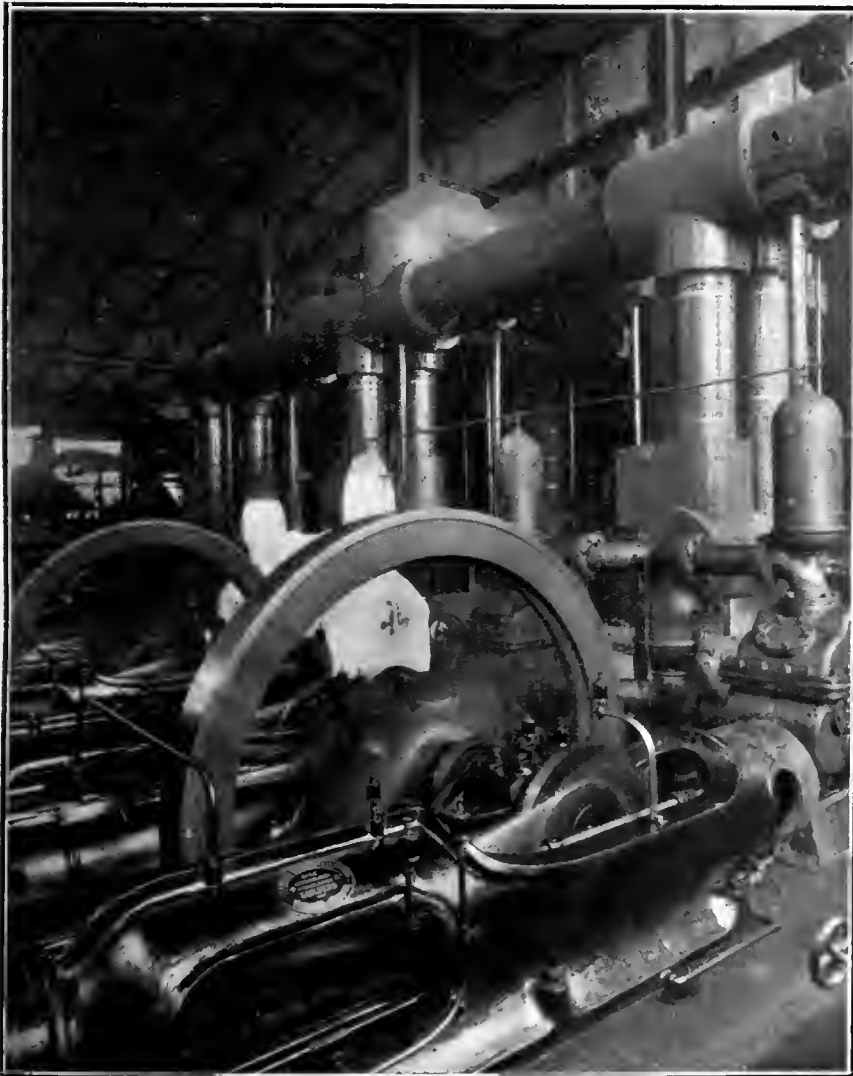

FIG. 4. VIEW IN ENGINE ROOM OF STEEL CO. OF CANADA REFRIGERATING PLANT, HAMILTON, ONT., SHOWING BRINE PUMPS AND THE PIPING INSULATED WITH CORK.

nearly so severe. Any good pipe covering firm can supply a sectional covering for cold water lines. The material of which it is made should be impervious to moisture. Asbestos coverings are not satisfactory for this purpose.

Brine Coolers.

Brine coolers of the shell type are difficult to insulate properly. The body of the cooler should have cork laggings held in place by metal bands. The ends should be encased in a tight wood box composed of two layers of matchings with waterproof paper between and filled in with granulated cork. The ends should be made so as to be easily removable for repairs or inspection.

Brine Tanks.

Sheet cork embedded in asphalt and coated with the same material should be laid under the area of the tank. The thickness should be as specified under cold rooms. After the tank is put in position 2 in. by 10 in. scantlings should be erected around the sides, sheeted with two layers of $\frac{7}{8}$ -inch matchings on outside, with waterproof paper between and the space between the studdings filled with fine granulated cork. If the top has to be insulated the cover should be made in sections of convenient size built up of wood, matched top and bottom, with sheet cork between and having a layer of waterproof paper on both sides of the cork.

The packing around the sides of the tank is an exception to the rule laid down in the article on cold rooms. Sheet cork could be used on the sides, but on account of the difficulty of applying it so as to withstand the expansion and contraction it is only used occasionally in this position.

The continuation of this paper, taking up the steam end, will appear in a future issue.



THE LIGHTING OF WORKSHOPS.

ENGINEERING workshops, which in every other respect may be admirably equipped, are frequently most deficient in artificial illumination. It is by no means an easy matter to decide which is both the most effective and most economical method of lighting, for both requirements and conditions vary to a considerable degree. Although ample light generally does tend to increased output, superior quality of workmanship and freedom from accidents, illumination can be given both in excess and in the wrong places, with the result that waste ensues or the eyes of the workpeople are affected. The subject is one which will well repay a considerable amount of thought on the part of works managers, and it was a happy idea on the part of the president and council of the Manchester Association

of Engineers to invite the advocates of the three chief illuminants, gas, electricity and oil, to present papers on the subject of workshop illumination before the members recently.

Features Emphasized.

Although the authors of the papers did not succeed in bringing down their facts to a common basis for comparison, either as regards cost or efficiency, a good deal of helpful information was given, especially regarding the employment of the rival illuminants, gas and electricity, and the general impression left after the discussion was as follows:

1. As regards cost, there is not much to choose between gas and electricity, with the former costing 50 cents per thousand cubic feet and electricity at 2 cents per unit.

2. That oil vapor lamps are quite dependable substitutes where gas and electricity are not obtainable.

READER, WHAT DO YOU KNOW?

Among readers of Canadian Machinery there is a clearly defined sincerity of desire to know how each overcomes the daily tasks of the machine, pattern and blacksmith shops, the foundry and boiler shops. It is believed that your methods and devices, while good, may be improved, and thereby made more valuable if you publish them, so that other brains may work on them. We will provide the setting and pay you for the material. When your fellow tradesman puts the superstructure on your foundation, we pay him and pass the "kink" on to you, free. Get into the game.

3. That for general lighting, gas and electricity are both equally suitable.

4. That electricity lends itself better than gas for local lighting, such as is required with machine tools, etc.

Gas engineers during the last few years have put up a splendid fight with their rivals, the electricians, and they resent seeing, in many engineering shops, gas condemned after such an unfair comparison as is only too often afforded by contrasting the old flat flame burner with the metallic filament electric lamp. With incandescence mantles a cubic foot of gas at a high pressure will give an illumination twenty-five times as great as that obtained from an ordinary flat flame. Even with this advantage, however, for small local lights, such as are required frequently, the metallic filament electric

lamp is undoubtedly the most convenient.

Systems of Lighting.

The papers dealing with both gas and electricity demonstrated pretty clearly that a mixed system of general and local lighting is the best method of illuminating machine shops, but before installing either system it is always advisable to investigate the daylight conditions, as these have a material effect on the requirements of the workpeople. For instance, recent tests carried out in a shop showed that the artificial illumination of automatic screw-cutting machines varied between 9 and 15 foot-candles, whereas during the daytime an illumination equivalent to 3 foot-candles was all that was obtainable and satisfied the workers. In another case the daylight illumination was 37 foot-candles and the artificial illumination as much as 133 foot-candles, showing that the workers are frequently given a higher degree of light than is obtained in daylight or than is necessary.

Difficult to Standardize.

One of the great difficulties in fixing a definite standard of artificial illumination is the difference in the Albedo of the materials being worked upon. The Albedo factor of machine shop work is low, especially where iron is being worked, and the degree of illumination is high in consequence. In fact, for very fine and accurate workmanship the illumination theoretically required is many times that necessary for reading or writing. In this connection some instructive figures are obtainable from the United States, where much attention is paid to this subject. In machine shops, for general illumination only—when special lights are provided for the machines and benches—1.5 foot-candles is considered sufficient; for bench illumination, 4 foot-candles; for machines or machine shops with no general system of illumination, 6.7 foot-candles; general illumination of foundries, 3 foot-candles; and power-houses, 2.5 foot candles.

In order to avoid waste of power by the illumination of portions of workshops where there is no necessity for light, local lighting is undoubtedly the most economical, giving each man his own source, say, 50 candle-power, over an area of 10 square feet, which gives an illumination of 5 foot-candles, by placing the lamp at a height of 3 feet above the area to be lighted. As a simple basis for calculating the power required to light a workshop by electricity on the local principle, there was suggested a supply equal to 10 watts per man plus a small amount for general illumination. Efficient opaque reflectors must be used and glare avoided.

The Nature and Manufacture of Shear Steel

By A. P. Hague *

This article describes step by step the various stages in the making of the Shear Steel used for the highest class of edge tools.

TO many the term "Shear Steel" has but a vague and indefinite meaning. The "man in the street" certainly knows that cutlery made from shear steel is of the finest quality and carries a remarkable cutting edge. But beyond this he usually knows nothing of the many intricate processes, both chemical and mechanical, which the iron ore must necessarily be subjected to before it emerges as shear steel. In this article it is proposed to describe briefly the evolution of the shear steel from the iron ore to the finished rolled strip from which the finest razors and general cutlery are made.

Iron Ore.

The ore used is the magnetic iron ore of Sweden, or magnetite. The chemical formula for the pure ore is $Fe_3 O_4$, which contains 72.4 per cent. metallic iron and 27.6 per cent. oxygen. It is, however, never found in a pure state, being usually mixed with varying percentages of alumina, silica, lime magnesia and compounds of sulphur, phosphorus, etc. A typical analysis is as follows:—

Ferrie Oxide	= 59.19	per cent.
Ferrous Oxide	= 25.82	"
Manganous Oxide	= .94	"
Alumina	= 1.30	"
Lime	= 1.6	"
Magnesia	= 2.31	"
Silica	= 3.22	"
Carbon Dioxide	= 3.02	"
Phosphorus Pentoxide	= Trace	
Sulphur	= Trace	
Combined Water	= 0.21	per cent.
Organic Matter	= Trace	

The purity of the ore varies greatly, and it may be here stated that only ore of exceptional purity, containing only the merest traces of the compounds of sulphur and phosphorus, can be used when shear steel is to be the final product. The ores of Dannemora and Persberg are remarkably free from these deleterious elements and are thus eminently suitable, whilst those of North Wales and Lapland are contaminated and are consequently worthless for the production of this grade of steel.

Magnetic Separation.

The ore as mined by blasting is mixed with a lot of useless veinstuff. The larger pieces of ore can be picked out from amongst this quite easily, but the smaller pieces can only be obtained by subjecting the crushed mixture to the influence of powerful electro-magnets,

which, owing to the natural magnetic properties of the magnetite, readily gather together the fine magnetic ore and leave the useless gangue to be drawn away from time to time.

Calcination.

The ore is next carried to firebrick stoves, or kilns, heated by the waste gases from the blast furnaces, and is there raised to a bright red heat and maintained so for a number of hours. This operation drives off a lot of the sulphur, existing mainly as sulphide of iron, and also renders the ore porous, which facilitates the next operation of

Smelting.

This operation is carried out in the blast furnace, the object being to obtain metallic iron separated from the various oxides with which it has been so far united. In Sweden the blast furnaces, used for the reduction of the iron ore and production of the so-called "Charcoal Pig," are small, very often only carrying a charge of a few tons. The coarsely crushed ore, together with the requisite amounts of charcoal and limestone, used as fuel and flux respectively, are charged in at the top of the furnace. Hot air is blown in through a number of nozzles or tuyeres situated at the base of the furnace and the fuel is soon raised to incandescence, reducing gases are produced and these permeating the ore effect the reduction of the iron from its oxide. The limestone added combines with the earthy matters of the ore or gangue and forms an easily fusible slag.

The metallic iron and slag fall down into the well of the furnace, and there the slag separates and floats on the surface of the iron. When the slag reaches a certain level it flows out through the slag notch, whilst the iron is tapped off from time to time and allowed to flow into the sand pig beds, where it solidifies.

Pig Iron.

We now have a crude iron known as Swedish Charcoal Pig Iron. This may contain 5 to 6 per cent. of impurities and is graded in three classes according as the freshly fractured surface of a pig shows a grey, mottled or white appearance.

Typical analysis would be:—

	Grey	Mottled	White
	%	%	%
Combined carbon	0.3	2.0	3.7
Graphite	3.6	2.0	.30
Silicon	.8	.55	.20
Manganese	.3	.30	.30
Sulphur	.02	.02	.02
Phosphorus	.03	.03	.02

As will be seen from the above analysis the impurities the iron still contains are very considerable; so it must be purified still further by puddling.

Puddling.

This process is carried out in Sweden either in the Swedish Lancashire hearth or the Swedish Walloon Furnace. The operation is to surround the pig iron with charcoal and then by means of a blast of air raise the temperature of the ignited fuel, and simultaneously that of the pig iron, until the iron is almost fused. Then by means of long iron bars the iron is literally washed with charcoal and oxide of iron on the hearth. In this manner the relatively large amounts of carbon, silicon and manganese which the pig iron contained are eliminated. The carbon burns, whilst the silicon and manganese unite with oxide of iron and form a slag, which is tapped off.

Shingling and Rolling.

After thus eliminating the impurities the iron, which is now in a pasty condition, is collected into a ball and is hammered or squeezed until quite solid and most of the slag which was incorporated with it has been expelled. The result is a rectangular bloom or billet which is still very hot. It is therefore dragged across the floor and hammered or rolled into a flat rectangular bar, the hammered bar being preferred for the manufacture of shear steel.

Bar Iron.

The flat rectangular bar, having a section about $3\frac{1}{2}$ inch by $\frac{5}{8}$ -inch and about 12 feet long, known as Swedish Bar Iron and may be a Walloon Bar or a Lancashire Bar, according to the process of purification it has undergone. It is practically pure iron as the following analysis will show:—

Iron	99.81%	Carbon	0.05%	Silicon	0.03%
Manganese	0.09%	Sulphur	0.01%	Phosphorus	0.01%

In addition to the above impurities there is always a little slag scattered through the bar at irregular intervals.

The vast difference in the chemical composition of the pig iron and the bar iron is at once apparent. The mechanical properties of the two differ also in as striking a manner, for example tests may give:—

Pig Iron.

Maximum stress = 25,000 lbs. per square inch of cross section.
Elongation % on 2 in. = Nil.
Reduction of area % = Nil.

Bar Iron.

Maximum stress = 45,000 lbs. per square inch of cross section
Elongation % on 2 in. = 40 per cent.
Reduction of area % = 74 per cent.

*Associate of Metallurgy, Sheffield University.

The foregoing processes all take place in Sweden. The bar iron is now shipped to Sheffield, where the next stage in the production of shear steel takes place, viz., the conversion of the bar iron into steel in the cementation furnace.

Cementation.

The conversion of bar iron into steel is merely a matter of introducing sufficient carbon into the iron to give a steel of the requisite temper or hardness. The bars, then, are packed into long firestone or iron converting pots, with charcoal completely surrounding each bar. When the pots are full a layer of wheelswarf, two or three inches thick, is placed on the top. The pots are then put in the furnace and gradually raised to a bright yellow heat, say 1,150 deg. C. The increase in temperature is very gradual and during the process the wheelswarf first dries and then fuses, effectively sealing the pots and excluding all air.

The bars are kept at a yellow heat for from five to twelve days, depending on the degree of carburization required. At the end of this period the fires are allowed to die down and the bars to cool. The whole operation may take twenty days. When the bars are cold they are withdrawn and are found to be covered with blisters, hence the name blister bar. These blisters are caused by the action of the carbon, or gaseous carbon, compounds on the enclosed slag of the original bar iron, whereby blisters of steel, as it were, are blown by the gases evolved.

Blister Bar.

Each bar is now taken and one end broken off. From the fracture so obtained the carbon percentage is judged and so a number of grades are obtained, described as No. 2, No. 3, No. 4, etc. The carbon in the different grades is approximately as follows:—

	No. 2	No. 3	No. 4	No. 5	No. 6
	p.e.	p.e.	p.e.	p.e.	p.e.
Carbon	= .5	1.1	1.35	1.6	1.8

Each maker has, however, his own particular number for a certain carbon content.

Blister steel is very coarsely crystalline, brittle and is not homogeneous, the carbon content varying from the outside to the centre of the bar. Consequently the next operation is to produce homogeneity. The blister bar is therefore heated up and the blisters flattened down under a steam hammer. The bars are then known as plated bars. These are cut up into lengths of about 20 inches and six or seven such pieces are piled together, one on the top of the other, and so made into a faggot. This is covered with lime, borax or sand and raised to a melting heat, the whole six or seven plated bars being then welded into a composite bar. This is next rolled down

into the section desired and is known as single shear steel.

If double shear steel is required the welded composite bar is marked half way along its length, raised to a welding heat and bent over. The two halves are welded into one bar, so that there is now a bar made up of 12 or 14 separate plated bars. This is then rolled to the desired section and double shear steel of great uniformity is secured, from which the smith makes the particular tool required.

Thus it is seen that shear steel is simply an alloy of iron and carbon in which, thanks to the use of exceptionally pure raw material and fuel, the impurities, silicon, manganese, sulphur and phosphorus, are reduced to a minimum.

A typical analysis of sheer steel suitable for a razor is: carbon 1.6 p.e., silicon .03 p.e., manganese .08 p.e., sulphur .01 p.e., phosphorus, .015 p.e.



A SUGGESTED MOTOR FEATURE.

By D. A. Hampson.

TO whom has the exterior appearance of an electric motor not appealed? The general smoothness of design, the sweeping curves, the generous fillets are ever a delight to the eye. But what of the man who has to set and align one of them with a shaft possibly at some distance from the motor? Symmetry is quickly forgotten, and in its place comes one great wish—a wish for two flat surfaces, not artistic, perhaps, but bearing a known and accurate relation to the motor shaft.

Of course, the base of the motor may be planed off and the yoke or spider carrying the bearings may bolt to the faced ends of the centre frame, which may be accessible at spots if the paint is scraped off, or the motor may slide on planed rails. Again, the pulley might be removed and the oil cover taken off the other end, exposing the shaft so that measurements could be taken from a plumb line dropped somewhere near.

Who wants, however, to dissect even a ½ h.-p. motor to line it up when suitable spots could be so easily provided by the makers? Why could not two pads be added on top of the frame, as far apart as possible, and faced off? Then a good-sized level could be laid across right in plain sight, and the certain error caused by using a level on a stub shaft would be avoided. Further, the hubs at each end could be turned to the same diameter for a distance of ½-inch, and a line dropped to them, or a cut might be taken along the edge of the feet and planing spots on top of them dressed off.

These small improvements would cost little, and would be a real help to millwrights or electricians.

A NEW WAGON LOADER.

THE loading of bulky material, such as coal, coke, limestone, etc., into box cars is often necessary when more suitable equipment is not available, and the simplest method is to lead such material into the cars through a gravity chute. On this principle a new form of box-car loader has been designed by the Fairbanks, Morse Co., of Chicago.

Loader Features.

Apart from the supporting carriage, the loader consists essentially of a bifurcated discharge pipe or chute which leads the material from the lip screens of the loading pockets to two horizontally curved spouts which are projected into the car at will, and may be adjusted to suit practically any condition of flow and delivery. These chutes are lined with bronze to reduce friction, and the material acquires sufficient velocity while traveling down the spout to carry it to the ends. In operation the height of the curved spouts is first adjusted to suit the door of the car to be loaded, and the spouts are extended until their ends are about 25ft. apart and project well into the ends of the car. Loading is then begun, and as the coal, coke, or other material piles up at the ends of the spouts, they are withdrawn so that their ends are kept just clear of the heap. By the time they are completely withdrawn the car is full. The loader travels on its own track from one discharge chute to another as required, and is self-propelled by an electric motor.

Control Mechanism.

The movement of the loading chutes is accomplished by three hand wheels. One serves to raise and lower the chutes to suit the varied heights of the cars; the second controls the movement of the spouts in and out of the car; and by means of the third the spouts are tilted so as to control the velocity of the material, and thus reduce breakage. All the moving parts are carefully counterbalanced, so that but little power is required to adjust them, and the capacity of the loader is practically limited only by the capacity of the lip screens which deliver the material to it. Ordinarily a 40-ton car can be loaded in from 6 minutes to 8 minutes.



Iron and steel attain their maximum strength at temperatures of from 400 deg. to 650 deg. Fah. A test bar of steel showed a tensile strength of 75 tons per sq. in., but when heated to 1,600 deg. Fah. the tensile strength had dropped to about 10 tons per sq. in.

Record Steel Output in the United States During 1912

The figures and data appearing in this article have been abstracted from the Journal of Commerce, New York, and indicate to a remarkable extent, the high degree of successful production output which characterized the iron and steel trade during the past year.

LARGE orders and heavy specifications for finished steel products formed a solid foundation for the steel industry at the beginning of 1912, and the trade entertained high hopes for more substantial monetary returns to be derived from the building of the superstructure during the calendar year.

Expectations were more than realized, and one result was the expenditure of \$50,000,000 by the steel companies to increase capacity of furnaces and mills, a marvellous development, when it is recalled that early in 1911, the excess productive capacity was overwhelming and disheartening. To-day, mill rolling schedules are complete for several months; specifications are pressing for the second quarter, and contracts booked are equivalent to the capacity of the mills for nine months, while some manufacturers have taken orders for delivery in the fourth quarter of 1913, and even for shipment into 1914. Never before has the pressure for deliveries been so great or so insistent or so long sustained.

High Capacity Output Percentage.

Early in 1912, the mills were operating 75 per cent. of capacity. This was quickly increased to 80 and 85 per cent., and as soon as possible to 90 to 95 per cent. of rated capacity. At times, it was possible to employ 97 to 100 per cent., but, as was to be expected, it was a practical impossibility to keep full capacity busy indefinitely. Operations at high pressure called for more frequent repairs and increased liability to accidents. At times, inadequate transportation facilities and sporadic strikes prevented the ready assembling of raw material or obstructed the distribution of finished products. The strong preference shown for open hearth steel by consumers was also a handicap upon the operating departments.

Obstacles, however, only increased the energy displayed by the working forces, and resulted in establishing new high records of production in all departments. The gain in steel output over 1910—the year of previous greatest production—was 15 per cent., while the increase in ingot output over 1911 was 26 per cent. Slightly smaller gains were made in iron as distinguished from steel, as the foundry iron consumers were slower to feel the urge from the wave of greater prosperity.

Congestion of Unfilled Contracts.

With each succeeding month new business rolled into the mills far in excess

of the capacity to produce—culminating in October—which means, of course, congestion of unfilled contracts. The recovery in market values, which began during the last quarter of 1911, continued throughout the year 1912, ranging from \$4 to \$10 per ton, or a rise of \$5 to \$13 per ton from the lowest points in 1911, without taking into account the premium of \$4 to \$6 per ton obtained for preferred shipment on special products. The largest interests have thrown the weight of their influence against higher prices, but a further appreciation in some lines seems probable before the upward movement has spent its force.

Railroad Material.

The railroad companies were a factor in the year's developments, especially during the last six months, when urgent necessity for rolling stock and motive power forced many small roads, as well as the great trunk lines, to place heavy orders for all kinds of equipment. In the last quarter of the year more cars were ordered than during the first six months, and many contracts are still pending. The car shops and locomotive builders booked more orders in 1912 than in any year since 1905 and 1906, which were the years of maximum buying.

It was the rail mills, however, that felt the greatest force of the railroad contracts. Rail orders were never so great, being a little less than 5,000,000 tons, nearly half of which tonnage is for 1913 shipment. Orders for about 1,500,000 tons were carried over from 1911, indicating that the rollings in 1912 were approximately 3,000,000 tons.

Orders From Other Sources.

Too much stress must not be laid upon the railroad support of the steel mills in 1912, however. Orders from other sources than those dependent upon railroad patronage were more important, and called for a greater aggregate tonnage. The total volume of business was so heavy that the railroads—directly and indirectly—contributed only 33 per cent. to the orders placed—that is, a normal proportion after four lean years.

Total Contracts Placed.

It is estimated that total contracts were placed for 26,500,000 tons of finished steel products during the year, about 8,500,000 tons being derived from the railroads and railroad equipment manufacturers. The total orders booked for finished products by all the steel com-

panies thus exceeded the production of such products by 4,000,000 tons, and it is estimated that new orders exceeded shipments by 5,000,000 tons, while there is a back log of 14,000,000 tons more awaiting rolling and shipment in 1913 and 1914.

In the steel structural trade—including bridges and building—the railroads failed to maintain the 1911 proportion of total contracts in a record-breaking business done by the fabricating shops. The total tonnage booked was 1,510,000, to which the railroads contributed 384,337 tons for bridges and terminals, or 25½ per cent. The 1912 contracts exceeded the 1911 orders by 15 per cent., and were also slightly in excess of the 1906 bookings, thus establishing a new high record. The American Bridge Company secured about 46 per cent. of the total tonnage.

Export Trade.

The export trade made even a more phenomenal expansion than domestic business, reflecting the unprecedented activity in iron and steel products in international markets. It is estimated that the United States shipped close to 2,800,000 tons of steel products in 1912, and booked orders for 3,000,000 tons on foreign account. The profit upon this business was never so great as in the third and fourth quarters; prices were as satisfactory, if not more so, than in the home trade. For the time being, tariff revision has small terrors for the industry.

World's Production of Pig Iron.

The world's production of pig iron in 1912 was close to 75,000,000 tons, of which the United States produced about 40 per cent., although its blast furnace capacity is approximately 42,000,000 tons annually. Furnaces with an annual capacity of 35,500,000 tons were active in the latter part of the year, producing iron at the rate of 32,600,000 tons per year. Stacks with 2,000,000 tons capacity will probably blow in during the next few months, leaving a reserve capacity of approximately 5,000,000 tons per year. The steel companies produced a little under 22,500,000 tons, and the merchant furnaces about 7,230,000 tons in 1912. Merchant blast furnace interests sold about 7,435,000 tons during the year, or a little in excess of the output. Taking into account the increase in the export, and the decrease in the import movements, together with a net decrease of 800,000 tons in surplus stocks, it is

indicated that the total consumption of pig iron in the United States in 1912 was in excess of 30,300,000 tons, or a gain of nearly 24 per cent. over the apparent melting in 1911.

U. S. Iron, Steel, Ore and Coke Output.

	1910.	1911.	1912.
Ore, L. Superior.	43,442,397	32,793,130	48,500,000
Ore, all sections.	55,889,734	43,550,633	60,000,000
Pig iron & alloys	27,303,567	23,649,547	29,650,000
Coke, Con'sville	18,689,722	16,334,174	20,410,000
Coke, all sections	41,708,810	35,551,489	42,000,000
Steel Ingots and castings	26,094,919	23,676,106	30,000,000
Rails	3,636,031	2,822,730	3,900,000
Plates	2,807,728	2,334,341	3,225,000
Sheets	1,435,419	1,358,110	1,650,000
Wire rods	2,241,830	2,450,453	2,600,000
Structural shapes	2,266,890	1,912,367	2,695,000
Fabricated steel shapes	1,196,000	1,500,000	1,510,000
Merchant bars, iron and steel.	3,785,731	3,047,362	4,350,000
Th & ferne plates	722,770	783,900	900,000
Wire nails and spikes, kegs	12,704,902	13,437,778	14,100,000

U. S. Pig Iron Output.

1866.	1,205,663	1882.	4,622,323	1898.	11,773,934
1867.	1,305,023	1883.	4,595,510	1899.	13,620,703
1868.	1,431,250	1884.	4,007,868	1900.	13,789,242
1869.	1,711,287	1885.	4,044,526	1901.	15,878,354
1870.	1,665,179	1886.	5,663,329	1902.	17,821,307
1871.	1,706,793	1887.	6,417,148	1903.	18,009,252
1872.	2,548,713	1888.	6,489,738	1904.	16,497,033
1873.	2,500,963	1889.	7,003,642	1905.	22,992,380
1874.	2,401,262	1890.	9,202,703	1906.	25,307,191
1875.	2,023,733	1891.	8,279,870	1907.	25,981,361
1876.	1,868,961	1892.	9,157,000	1908.	35,936,018
1877.	2,066,594	1893.	7,124,502	1909.	25,795,471
1878.	2,301,215	1894.	6,057,388	1910.	27,303,567
1879.	2,741,853	1895.	9,446,308	1911.	23,649,547
1880.	3,835,191	1896.	8,623,127	1912.	29,650,000
1881.	4,144,254	1897.	9,652,680		
		1st half	2nd half	Total.	
1895		4,087,558	5,358,750	9,446,308	
1896		4,976,236	3,646,891	8,623,127	
1900		11,922,346	14,773,125	25,795,471	
1910		14,978,738	12,324,829	27,303,567	
1911		11,666,996	11,982,551	23,649,547	
1912		14,072,274	15,577,726	29,650,000	

U. S. Pig Iron Consumption.

	Tons.
U. S. Stock, Jan., 1912	1,800,000
U. S. production, 1912	29,650,000
U. S. imports, 1912	119,409
Total supply available	31,569,409
Exports, 1912	258,638
Stock est. Jan., 1913	1,000,000
Total withdrawn from supply	1,258,638
Apparent consumption	30,310,771

Railroad Equipment Orders.

1912			
	Rails.	Cars.	Loco.
January	500,000	15,000	198
February	254,000	5,643	343
March	340,000	11,946	363
Total first quarter	1,094,000	32,589	904
April	200,000	23,331	497
May	416,000	41,887	640
June	210,000	4,264	257
Total second quarter	826,000	69,385	1,394
Total first half	1,920,000	101,974	2,298
1911			
	Rails.	Cars.	Loco.
January	381,500	8,113	421
February	374,000	7,513	102
March	175,700	8,771	203
Total first quarter	931,200	24,397	786
April	218,034	5,520	190
May	160,000	3,600	206
June	164,000	4,467	164
Total first half	1,491,234	37,884	1,346
Total second quarter	563,634	12,587	500
1912			
	Rails.	Cars.	Loco.
July	125,000	25,857	593
August	465,000	26,000	339
September	589,200	12,925	400
Total third quarter.	1,179,200	64,782	1,332
October	823,000	43,608	325
November	504,000	37,665	232
December	550,000	32,837	220
Total fourth quarter	1,887,000	114,110	787
Total second half	3,066,200	178,892	2,119
Grand total	4,980,400	280,866	4,417

1911	Rails.	Cars.	Loco.
July	130,247	4,751	238
August	150,000	9,132	500
September	110,000	7,500	190
Total third quarter.	390,247	21,383	628
October	60,000	18,454	288
November	212,500	44,911	332
December	265,290	14,261	258
Total fourth quarter	537,790	77,056	878
Total second half	928,037	99,039	1,506
Grand total	2,422,291	136,423	2,852

of the following dimensions:—Positive plates, 20 $\frac{3}{4}$ in. wide by 29in. deep by 0.4in. thick; negative plates, 20 $\frac{3}{4}$ in. wide by 29in. deep by 0.31in. thick. The positive plates were of the Plante formation, cast in one piece, but the negative plates were of the improved box type composed of half-grids securely

World's Pig Iron Production (In Tons).						
	1905.	1906.	1907.	1908.	1909.	1910.
United States	22,992,380	25,307,191	25,781,361	15,936,018	25,795,471	27,303,567
Germany	10,843,979	12,478,067	13,045,760	11,813,511	12,918,000	14,793,325
U. S. Britain	9,592,737	10,149,388	9,923,856	9,281,840	9,664,900	10,216,735
France	3,028,376	3,314,162	3,588,949	3,391,150	3,600,000	4,032,459
Russia	2,931,257	2,700,000	2,800,000	2,748,100	2,817,000	2,956,000
Belgium	1,329,109	1,431,460	1,427,940	1,270,050	1,630,000	1,803,500
Aus. Hungary	1,300,000	1,270,000	1,383,000	1,250,000	1,900,000	1,990,684
Sweden	518,967	525,000	615,378	554,266	445,000	604,300
Canada	468,003	541,957	581,146	503,672	677,090	740,210
Spain	377,046	400,000	420,000	373,248	420,000	425,000
Italy	143,079	135,296	140,000	110,432	147,000	343,600
Japan	33,335	35,000	38,000	42,919	150,000	162,000
Other coun'ts.	200,000	100,000	200,000	200,000	171,000	241,420
Total	53,728,268	58,912,521	59,945,790	47,943,606	60,323,561	65,711,355

*Estimate.

A LARGE MINE HOIST.

AN order for what is believed to be the largest mine hoist in the world was recently placed with the Nordberg Manufacturing Co., Milwaukee, Wis., for the mine of the Inverness Railway and Coal Co., Inverness, Cape Breton Island, N.S. It is of the Nordberg-Corliss duplex double-drum type. The cylinders are 34in. by 72in., and each of two drums can be operated independently of the other. The load which the hoist is designed to lift is a train of 12 cars, each weighing 1,150lb., and containing 2,240lb. of coal. This load must be pulled up a 10,000ft. incline, which varies in slope from 16deg. at the surface to 35deg. at the bottom. The stress produced in the hoisting rope by this load is approximately 41,000lb., and this, together with the length of the cable, is the feature which makes the hoist probably the largest ever constructed.

LARGE BATTERIES.

A PAPER by Mr. F. H. Whysall on "The Use of a Large Lighting Battery in Connection with Central Station Supply," was read recently before the Institution of Electrical Engineers. It referred mainly to the results obtained during two years' working of the 12,000 ampere-hour battery installed in March, 1910, at the Manchester Corporation Electricity Works, which at that time was the largest battery ever constructed. The paper also showed to what extent the predictions regarding the use of the battery have been fulfilled and the relief obtained in the cost per unit supplied.

Composition of Battery.

The author said that the battery consisted of 210 cells, each cell containing 38 positive plates and 39 negative plates

riveted together, the spaces between them being filled with active material. Specially impregnated wooden separators were employed between adjacent plates, and a free space of 8in. was left at the bottom of the cell for the accumulation of deposit.

Duty of the Battery.

The chief duty of the battery was to take 3,000 kw. off the lighting peak. It was also regarded as a standby. Its chief duty, however, was load-levelling; it was, therefore, decided to have three hand-regulated reversible boosters, and to run them in parallel at times of maximum discharge. At other times one or two would be used as required. It might be noted, however, that such importance was attached to the question of overload in emergency that it was the universal custom on the Continent to use regulating cells in all central station batteries.

The improvement in load factor on the units generated, observed monthly over two years, was approximately 7 $\frac{1}{2}$ per cent., and the value obtained from the chart on 30 $\frac{1}{2}$ million units representing a saving of \$50,830. There were, therefore, two distinct annual savings on running charges due to the battery: (1) Standby boiler fuel costs; (2) difference between steam generation at 8 per cent. load factor and bare fuel cost.

The Canadian Bond Hanger & Coupling Co., Ltd., Alexandria, Ont., have had a test made on one of their "Spiro" compression couplings at the Drexel Institute, Philadelphia. The "Spiro" stood a load of 11,400 pound inches without slipping on its shaft. When tightened, it withstood a load of 20,000 pound inches, without the hubs being hammered. Descriptions of their power transmitting machinery are given in Catalogue 25.

MACHINE SHOP METHODS ^A_N ^D DEVICES

Unique Ways of Doing Things in the Machine Shop. Readers' Opinions Concerning Shop Practice. Data for Machinists. Contributions paid for.

AN INTERESTING RELIEVING ATTACHMENT.

By J. Davies.

ON one occasion we had to make a large hob for hobbing a worm wheel, and, as we had not an up-to-date tool room lathe fitted with a relieving attachment, the foreman devised the scheme here illustrated and applied it to an engine lathe. The latter had its leading screw at the back and its friction feed shaft at the front, as seen. The feed shaft was fitted with a cam (1) which gave the necessary reciprocating motion to the tool in combination with the coil spring (9) at the back of the slide rest. The feed shaft was, of course, geared to the lathe spindle in such a way that it made the same number of revolutions per revolution of the lathe spindle, as there were flutes in the hob.

Referring to the sketch (1) is the cam, which was made of machinery steel case-hardened, and fitted with a key to slide along the splined feed shaft. As may be seen, the cam is of a form to give a gradual forward feed to the tool, with a quick return, the latter being brought about by the release of the coil spring (9), which is compressed during the forward movement. This spring also keeps a constant pressure on the cam through the lever (4) and connecting pieces (2) and (6). It can be adjusted to any tension by nuts at each end of the rod passing through its centre and through the slide rest. Part of the circumference of the cam is con-

centric, in order to ease the tool to pause momentarily and ensure its not running into the cutting edge. Its di-

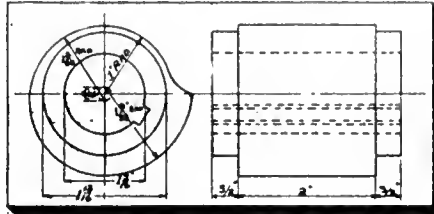

FIG. 2. CAM FOR RELIEVING ATTACHMENT.

mensions are seen in Fig. 2. Bolted to the lower edge of the apron is a cast-iron bracket (3), bored to suit the rod (2), for which it serves as a guide. The

fulcrumed in a forged jaw (5), which is bolted to the underside of the saddle.

The tool was fed in at every cut by the top side of the compound rest; and for running back the saddle to its original starting place for a fresh cut the lathe was stopped with the tool opposite one of the flutes, and the saddle run back without withdrawing the tool from the work. This secured more positive regulation of the amount of the cut.

To relieve the taper portion of the hob the tool rest was swung round to the proper angle and the tool fed in by hand. The tool used was 1 1/2 x 3/4 inches, ground at the point to 29 degrees to suit the worm. The insides of two threads were thus relieved simultaneously.

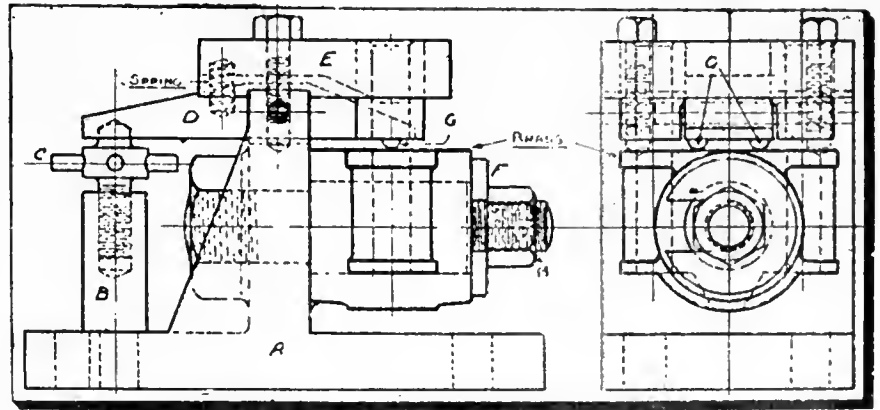

DRILLING JIG FOR CONNECTING ROD BRASSES.

rod (2) has a foot forged on one end to make contact with the cam. This foot is case-hardened. The lever (4) is

DRILLING JIG FOR CONNECTING ROD BRASSES.

By D. O. Barrett.

THE drawing shows a jig for drilling the brasses for the connecting rod of a gas engine. The two halves of the brasses are cast together, and after boring and milling, are drilled on this jig and are afterwards split. The back face of the brass being first milled, the hole is then bored and the ends faced. The brasses are held on a steel stud by means of a nut and slotted washer, in such a way as to be readily removable, the outside diameter of the nut (H) being smaller than that of the main body of the stud. The top piece (E) carries the two bushings. The steel piece (D) carries two round head case-hardened rivets (G) at the one end, which bear against the finished face of the brass, and bring it square with the drill bushings. The piece (D) is normally held down by means of a spring, but may be pushed up by means of a

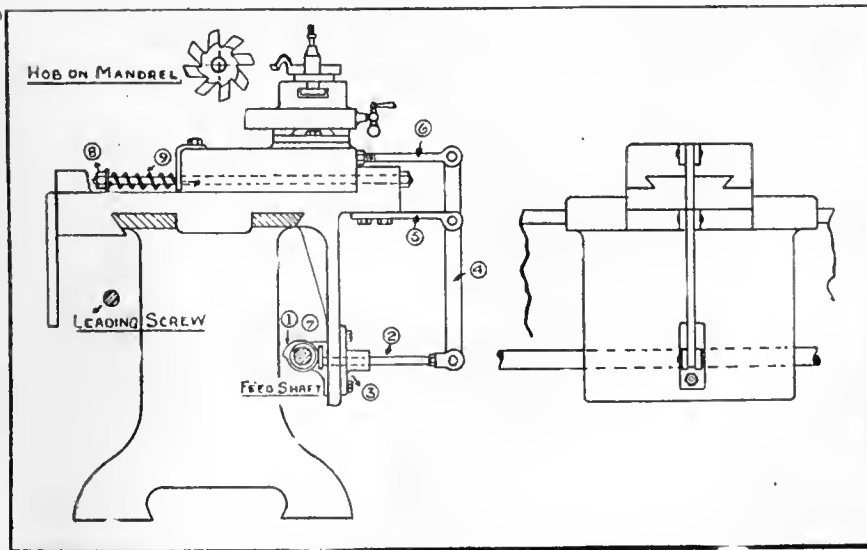

FIG. 1. AN INTERESTING RELIEVING ATTACHMENT.

capstan screw (C), after which the nut on the steel stud (H) may be tightened for holding the brass. This jig is very quick and effective.



JIG FOR BABBITTING LOCOMOTIVE VALVE STEM CROSSHEADS.

By A. E. Till.

THE device here shown was first used in the West Toronto shops of the Canadian Pacific Railway and has since been sanctioned by the general Master Mechanic for the use of the entire system. It should be mentioned that many engines on the above-mentioned road have their valve stems guided by a crosshead running on a short guide bar. The jig here shown was designed by the writer for babbitting these valve stem crossheads and has greatly reduced the cost of the operation.

Referring to the sketch, (A) shows the crosshead in place on the jig. The taper hole for the valve stem is placed upon the taper plug (B), which is located at the correct distance from the face (I), which corresponds with the lower side of the guide bar. The plug (B) is screwed permanently into the base plate (C) and so is the centre wedge (D), both of them being in line. The plate (C) is cupped out to receive the lower coned edges of the wedge plates (D) and (E). These wedges are also coned at the top and are there held together by a cast iron cap (F) and the nut (H).

After melting out the babbitt, the crosshead is retinned and is then put in position over plug (B) and centre wedge (D). The cupped recess in the base plate (C) is then blown free of all dirt, etc., and the side wedges (E) are in-

serted, forcing it off the taper plug. The side wedges will rise with it and are afterwards knocked free. When cool the crosshead is ready to be applied to the engine without any machining or seraping.

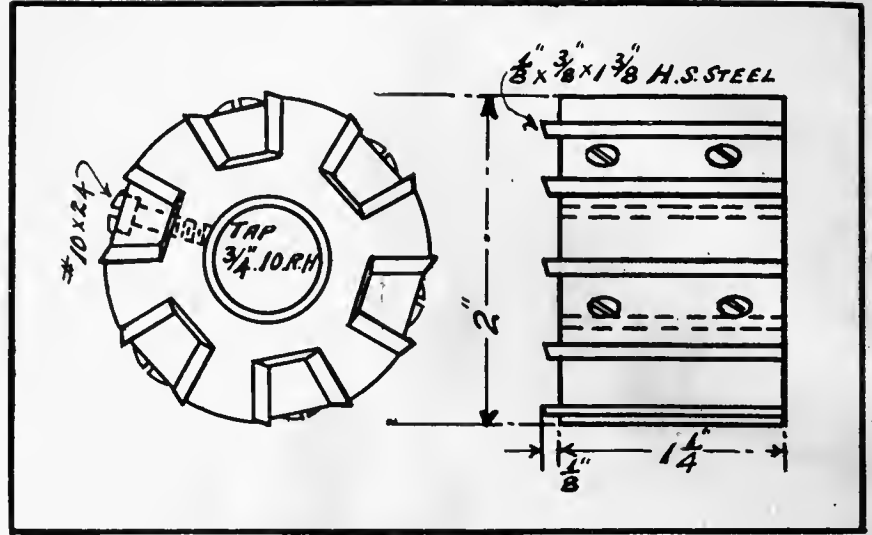

INSERTED BLADE END MILLS.

INSERTED BLADE END MILLS.

By D. A. Hampson.

serted. The crosshead is then knocked down securely upon the plug (B) and the wedges are tightened down by the cap (F) and nut (H). Clay is then applied at the bottom as shown and the babbitt poured.

To remove the work from the jig, the cap (F) is taken off and the nut on plug (B) is screwed up against the cross-

WE had eight or ten duplex millers running on cast iron parts. Both carbon and high speed steel cutters were used. All were solid cutters and we kept a stock of about one hundred of them. They ranged in size from 1½ to 3½ inches diameter, with plain and threaded holes from ½ to 1 inch diameter. The large amount invested in them, the semi-annual re-cutting of the worn specimens, and the increased labor in grinding them when again worn, made it imperative to standardize these cutters, as they had been made or selected from catalogues more or less hurriedly on account of the rapid expansion of business. Of course, an inserted blade cutter was selected. We made the bodies of machinery steel and cut them so that two high-speed steel blades were held in place by one clamping piece. A typical cutter (end mill) is shown in the drawing. Incidentally the number of teeth in a cutter was reduced twenty to thirty per cent., with a marked saving in the cost of sharpening. Gauges were made by means of which the blades could be extended evenly when worn.

The results were gratifying in every respect. While the first cost averaged about the same as new solid cutters, the renewal cost was greatly decreased, with no re-cutting expense and little worn down tool steel to throw away. As to finish of the work, this was in every case equal or superior to that obtained with end mills having a larger number of teeth.

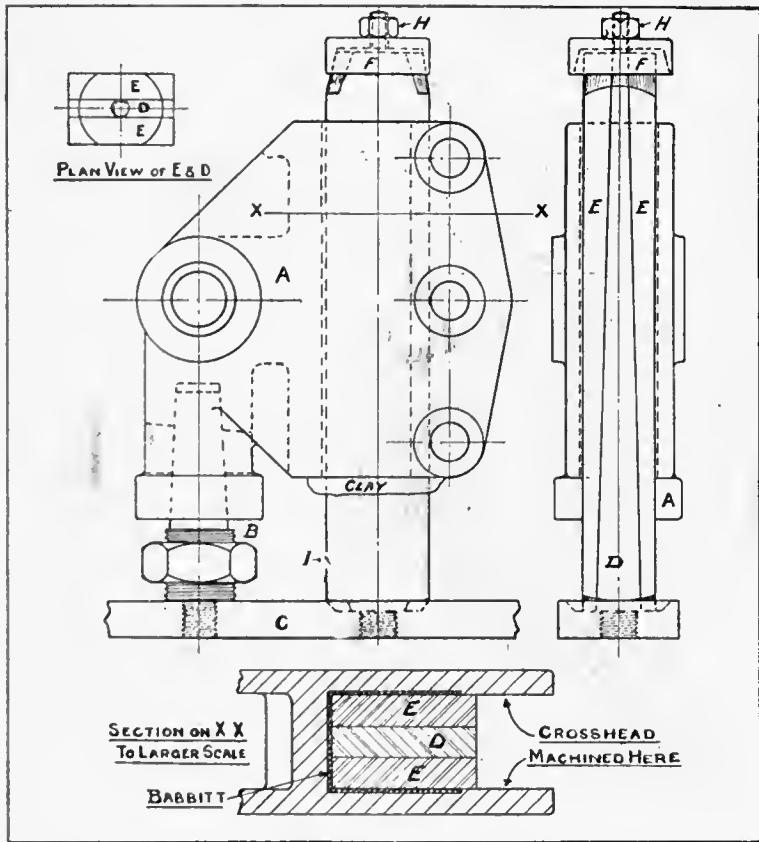

JIG FOR BABBITTING LOCOMOTIVE VALVE STEM CROSSHEADS.

DEVELOPMENTS IN MACHINERY

A Record of New and Improved Machinery Tending Towards Higher Quality and Economical Production in the Machine Shop, Blacksmith Shop or Planing Mill.

LATHE FOR TURNING PROJECTILES.

THE motor-driven lathe here illustrated is for turning projectiles. This service requires rigidity of equip-

older shops avail themselves of the electric current as a medium for the transmission of power, and several of the principal steel plants of the world even drive the largest rolling mills

as the power hammers available were suitable for relatively light work only.

The Nazel Engineering & Machine Works, Philadelphia, Pa., is now supplying a hammer known as the Beeche Air Hammer, which has already found favor among some of the leading locomotive builders, steel works, implement and machinery manufacturers and technical schools. This hammer has a number of interesting features, among which is that, being self-contained and providing its own compressed air supply, it can be installed wherever belt or electric power is available. The hammer embodies over 30 years' experience in the building of steam and compressed air hammers and various types of pneumatic power hammers, and was originally introduced with the idea merely of meeting cases in which a sufficient supply of steam was not available to operate a steam hammer. It is said to have proved so satisfactory, however, that it is now in many instances even replacing steam hammers. The general design of the Beeche hammer is illustrated in Fig. 1, which shows one of the smallest of these hammers. In con-

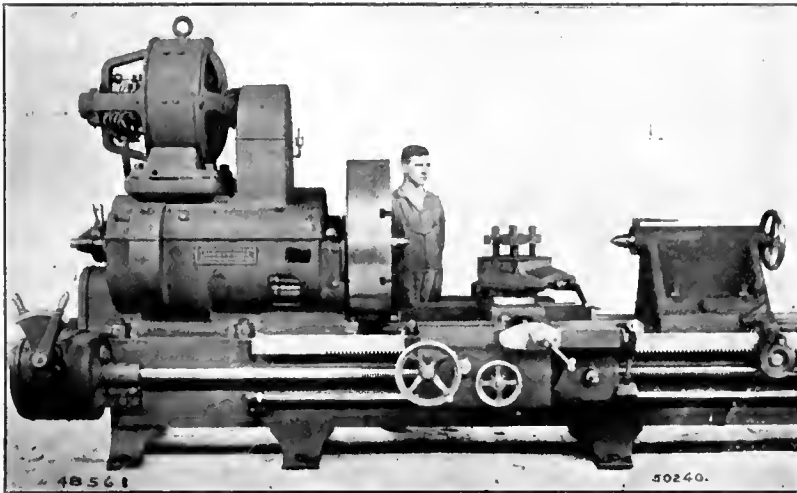

LATHE FOR TURNING PROJECTILES.

ment and wide speed range; a very high spindle speed being necessary when finishing the point of the projectiles. The lathe, which is of Pond make, is especially designed for individual motor drive, and is not a belt drive machine modified for motor drive. The motor is placed on the lathe head, thus saving floor space and doing away with any chance of injury to employees from their coming in contact with the motor or gears; at the same time the motor is protected from harm. The control handle, it will be noticed, is to the extreme right of the tool apron and very convenient for the operator.

The lathe is driven by a Westinghouse 20 h.p. machine-tool motor, 400-1,500 r.p.m. Commutating poles insure excellent commutation at all loads within its capacity, and with the liberal speed adjustment of the motor in combination with the gear changing device operated by means of the levers shown at the left end of the tool, the wide adjustments needed in turning up projectiles are made readily available.



A MODERN FORGING HAMMER.

THE tendency in modern shop practice, especially in the iron, steel and allied industries, is toward centralization of the power plant and the reduction of the steam piping system to a minimum. Most new, and many of the

direct by electric motors. But until recently, the heavy forge shops were still dependent on steam for their operation,

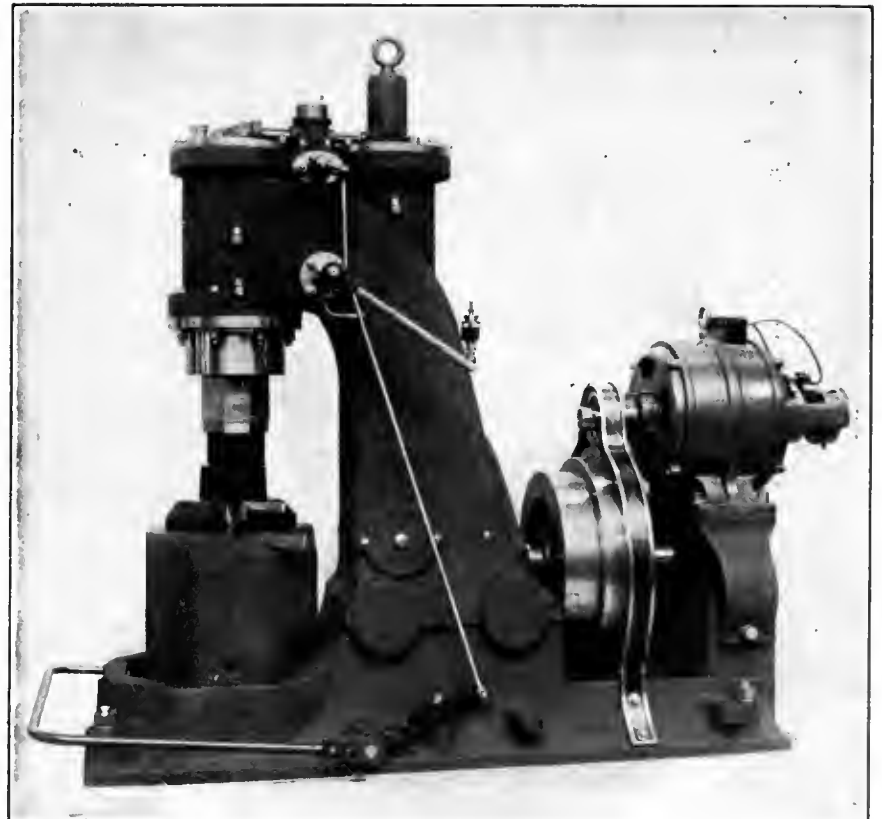

FIG. 1. BEECHE MOTOR DRIVEN AIR HAMMER.

struction the machine is very simple. The hammer frame is in one piece, which is fastened to the bed plate; the anvil block being separate. The working parts consist of two cylinders, in one of which a piston operates, actuated by a connecting rod attached to the motor-driven crank shaft. In the other, the ram or hammer head, slides vertically on closely fitted guides, and operates by vacuum and compressed air produced by the double acting piston in the first cylinder.

Another novel feature of this hammer is the construction of the ram or hammer head, shown in Fig. 2. This is in no way attached to any other part of the hammer. It is a hollow one piece forging, bored from the solid stock, and designed for long wear and severe service. The ram cylinder head has a central extension which enters the hollow ram, thus forming an air cushion against which the ascending ram reacts. The hammer is equipped with two air valves, which not only simplify operation, but place the hammer under positive control at all times. When the valves are closed the ram is held suspended, allowing space for the placing or manipulating of the work. When the valves are opened by means of the treadle or hand lever, the hammer goes into operation. The force of the blow depends on whether the valves are opened suddenly or gently, and is in-

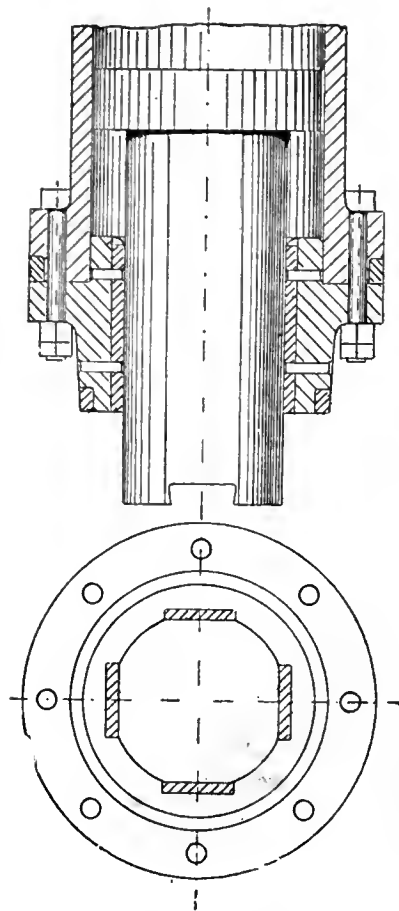

FIG. 2. RAM AND GUIDE, BEECHE AIR HAMMER.

creased from the lighter stroke as the valves continue to be opened. The treadle and hand lever are operated independently.

The Beeche hammer is built in six sizes with ram weights ranging from 66 to 770 pounds. As pointed out above, the energy for one blow is generated by two strokes of a double acting piston; the force of the blow, therefore, is very great. The 770 pound hammer will, it is claimed, forge to advantage stock up to 9-inch rounds. Another feature of this new hammer is its economy in power consumption. When geared direct to an electric motor the whole installation becomes very compact, but the hammer can be very easily altered to electric drive, as all the principal parts are the same for either type.



SIX-INCH CAM CUTTING MACHINE

FIG. 1 represents the 6-inch cam cutting machine with fixture for cutting face cams; the former being mounted on the outer end of arbor (A), while the blank to be cut is mounted on the opposite end of the same arbor. This arbor is driven by worm and worm gear from the universal joint, power feed shaft, shown to the front of the machine. The arm containing the work arbor pivots on the forward end at (B), and is guided at the rear end by guides,

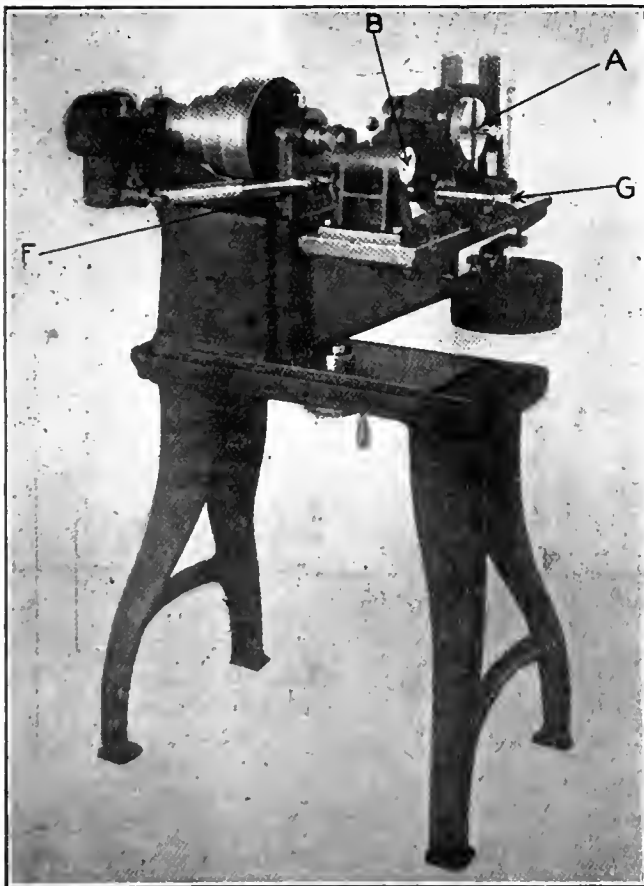

FIG. 1. 6-INCH CAM CUTTING MACHINE.

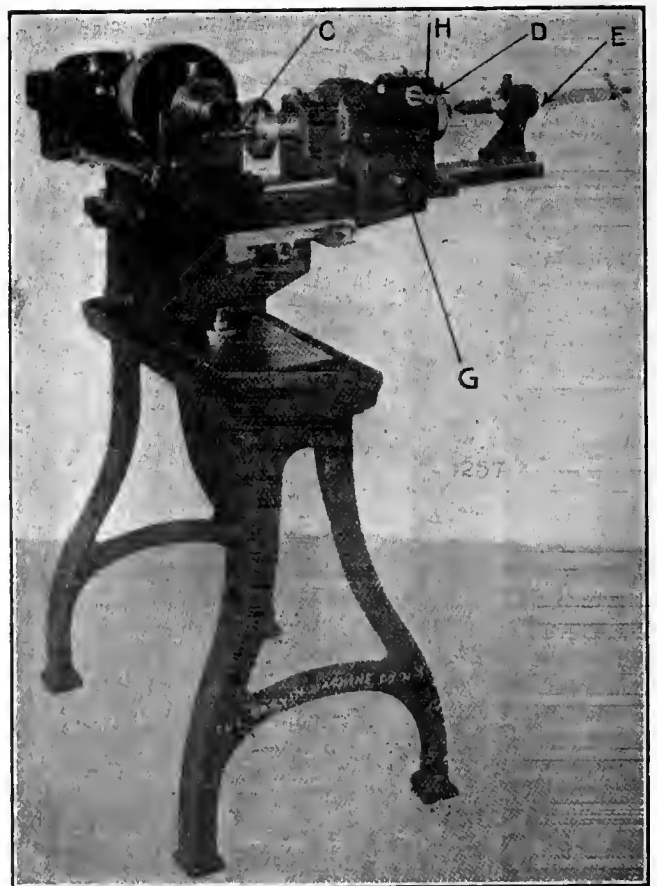

FIG. 2. 6-INCH CAM CUTTING MACHINE.

the whole being mounted on the same table. The arm has, in addition to its own height, that of detachable weights to keep the former on to the roller, offsetting the stress of cutter.

In changing from this face cam fixture, the entire slide is drawn off from the top of the knee and shelved in its completeness; the power feed, universal joint shaft readily detaching for this purpose. The barrel fixture is shown in fig. 2. The feed rotating the work on arbor (C) has the former mounted on the rear end of same at point (D), the former being kept against the rail by the adjustable spring tension rod (E). The feed in both attachments is disconnected by clutch (F), giving a hand control by wrench points (G). In this barrel fixture at times, there are quick returns, which require a quick let up of tension contact of former and roll. This is provided for by the use of a crank on pinion shaft (H), which in effect eases off the spring pressure and helps over this hard spot. The spindle of the machine takes No. 7 B. & S. shank cutters, and all gearing is housed and free from damage to itself or the operator.

The weight of the machine complete is 850 lbs.; it occupies a floor space of 36 inches by 43 inches, and is furnished by the makers, The Garvin Machine Company, Spring and Varick Streets, New York City, with either or both of the attachments mentioned above.



COMBINATION DISC GRINDER AND DRUM SANDER FOR WOOD PATTERNMAKING.

THE illustration shows the motor-driven patternmakers' disc grinder manufactured by Charles H. Besly & Co., Chicago, all gear guards being removed to show the construction. The disc wheel is of steel, 30 in. diameter x $\frac{3}{4}$ in. thick, and runs at 750 r.p.m. The work table serving the disc wheel is 14 inches wide by 40 inches long. It may be tilted and locked at any angle from 75 degrees to 135 degrees from the plane of the grinding disc, large distinct graduations being provided to govern this angular adjustment. The construction is such that the inside of the working edge of the table remains within 1-32 inches of the disc, regardless of the angular adjustment, and the supporting mechanism is at the back of the disc wheel and below the face of the work table, so that the top of table is always clear of obstructions from one end to the other. The work table has a vertical adjustment of 25 inches, and being supported by a round vertical shaft, it may be swung away from the grinding disc for convenience in re-

setting wheel or facing off extra large patterns.

The machine is equipped with four work table attachments, which are very valuable on wood pattern work, as follows:



FIG. 2. DRUM ATTACHMENT, BESLY PATTERNMAKERS' GRINDER.

- (1) Sizing circle gauge, for cylindrical and conical grinding.
- (2) Sliding bevel gauge, for simple and compound angle grinding.
- (3) Sizing bevel gauge, for simple and compound angle grinding to dimensions.
- (4) Angle plate for free-hand cornering of thin work.

The machine carries a telescoping dust hood, which may be piped to an exhauster for withdrawing the grinding

dust. The drum sanding attachment at the right has a work table 24 inches x 28 inches. It may be tilted and locked at any angle from 85 degrees to 105 degrees from the axis of sand drum. The sand drum shown is 2 $\frac{1}{2}$ inches diameter by 8 inches long, but drums from 1 inch to 6 inches diameter of any reasonable length may be used.

The work table has a central round opening, 8 $\frac{1}{2}$ inches diameter, into which are fitted circular plates, with centre holes to accommodate various sizes of drums. The sand drum runs at 2,250 r.p.m., and has a perpendicular reciprocating movement while running to equalize the wear on the abrasive. This movement is actuated by a crank and link, as shown, and is adjustable from 0 to 4 inches. The drive is a 3 h.-p. motor through sprockets and link belt maximum silent chain. The drum sanding attachment is driven through a Johnson self-oiling friction clutch, as shown, which enables the operator to stop the drum sander regardless of the disc wheel. This is very essential, as a disc wheel is usually allowed to run continuously, while the drum sander must be stopped in order to change to various sizes of drums for different work. The sand drum spindle is driven by a 2-inch quarter turn belt, and the reciprocating crank is driven through gearing by a 1 $\frac{1}{2}$ -inch belt.

Figure 2 shows the sand drum attachment finishing straight and curved inside surfaces with the tables tilted 11 $\frac{1}{2}$ degrees for draft. The machine occupies a floor space of 54 inches x 84 inches, and weighs 2,800 pounds. It is made with 30-inch or 40-inch diameter disc wheels, belted or motor-driven.

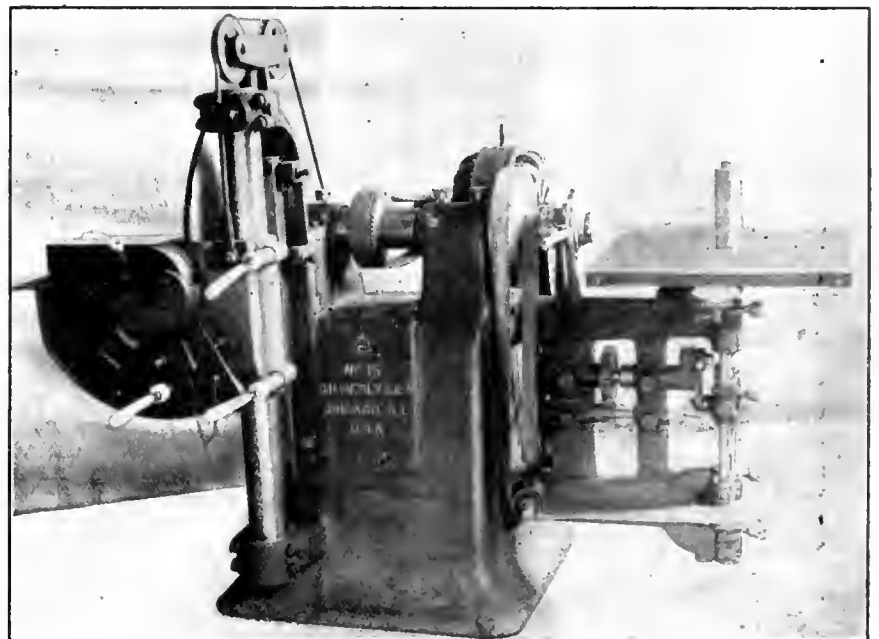

FIG. 1. BESLY COMBINATION DISC GRINDER AND DRUM SANDER FOR WOOD PATTERNMAKING.

FOUNDRY PRACTICE AND EQUIPMENT

Practical Articles for Canadian Foundrymen and Pattern Makers, and
News of Foundrymen's and Allied Associations. Contributions Invited.

THE VALUE OF SKELETON PAT- TERNS.

By J. H. Eastham.

CO-OPERATION between pattern shop and foundry foremen, if practised oftener in the matter of laying out new work, would result in many cases in a saving in the former department, and

twelve castings required. A glance at the plan view of the pattern in Fig. 2, which shows the heavy cross ribs and square facings on the under side heavily outlined in black, will demonstrate the futility of attempting to get what moulders call a "good bed in" from a complete pattern. Hence, spaces were sawn in the body, marked (cut) in the

allowed to slot the pattern. Still the job was simplified a little anyhow. However, as the pattern was about 4 feet square, the flanges 7 inches deep, and the job bedded into a permanent drag part to save the moulder howling for the over-worked crane every few minutes, considerable inconvenience was felt in tucking under the flanges as compared with the pattern of similar design shown at Fig. 4. This latter pattern was of skeleton design, some two-thirds of the face being left open. Strips were bedded to the inside of the flanges and drawn sideways after the removal of the pattern from the sand, the saving in coremaking and cost of moulding in this case amounting to about 25 per cent., compared with the handling of the piece shown in Fig. 3.

While, admittedly, wooden skeleton patterns, unless heavily battened, are not nearly so strong or rigid as those of solid design, less pounding down of the pattern on soft sand is needed when bedding in, as the interior of the job is more easily accessible to rammer and vent wire. The chances of swells and seabs, owing to unduly soft or hard places, are also reduced to a minimum.



HYDRAULIC RAM CASTING.

By William Fines.

THE production of thoroughly sound castings of various kinds is one of the problems that the foundryman is called upon to solve; prominent among the number may be classed those for hydraulic purposes.

For making sound hydraulic castings, it is essential that the mold be specially adapted so as to reduce blowholes and sponginess to a minimum, and that a suitable iron mixture be used. In order to cope with the first difficulty, the castings are invariably made in dry sand; or to be more explicit, the mold is made in the usual way and then placed in a stove to dry before use. This procedure allows of the metal being received in a hotter state than if it were a green sand mold and also helps it to maintain uniformity of composition throughout, as it is not chilled on entering the mold, neither is there fear of blowholes in the casting, due to the presence of moisture.

Feeding the Casting.

The next item that claims attention is that of feeding the casting, for no cast-

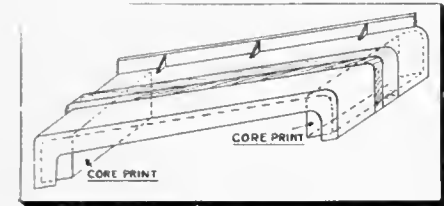

Fig. 1. The Value of Skeleton Patterns.

nearly always cut down foundry expense. Often, a costly, well-finished, complete pattern comes down to the foundry, and has to be hacked out of all recognition before coming into practical use. The case of the turbine side wall patterns, shown in perspective in Fig. 1, will make this clear to the average jobbing foundryman.

This pattern, measuring approximately 10 feet long by 4 feet wide, by 2 feet deep at the ends, with a flange under one side 10 inches deep, was, owing to pressure of business, made and delivered to the foundry in excellent condition by an outside firm of patternmakers. It was checked over and found correct in every detail. Obviously, the best way to handle a pattern of the above dimensions, both with a view to economising space on the foundry floor and reducing

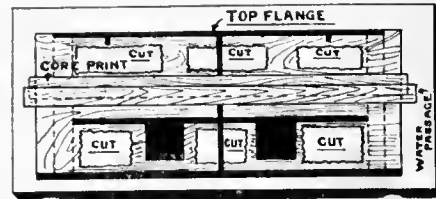

Fig. 2. The Value of Skeleton Patterns.

sketch: the ramming, ironing, and venting of the various corners, and face of the mould being thus made very simple, instead of almost impossible, with the pattern as at first provided.

A Furnace Door.

The rail furnace door pattern (Fig. 3), was sent to the foundry by a customer requiring 24 castings. The brackets shown on the top side were nailed and glued fast to the body, the whole pattern was beautifully finished from, say, a cabinet maker's point of view but as a paying line in the foundry it was decidedly below par. Per-

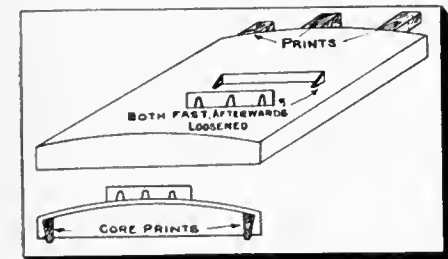

Fig. 3. The Value of Skeleton Patterns.

the cost of rigging, was to "bed in" the job. This method was adopted, a cinder bed being first laid at a convenient depth under the entire area of the casting.

The pattern was next lowered into the hole, levelled by parallel straight edges, and iron bearings rammed under the massive end coreprints, these to remain in position through the order of

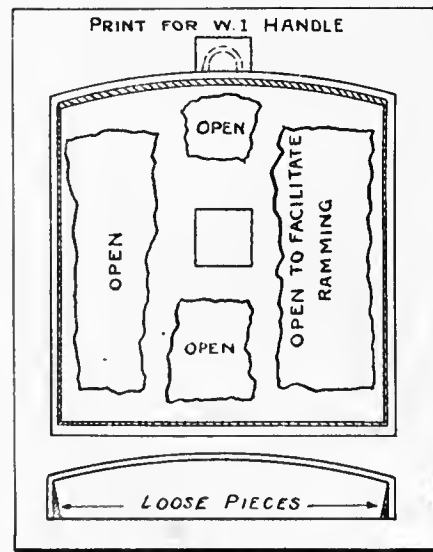
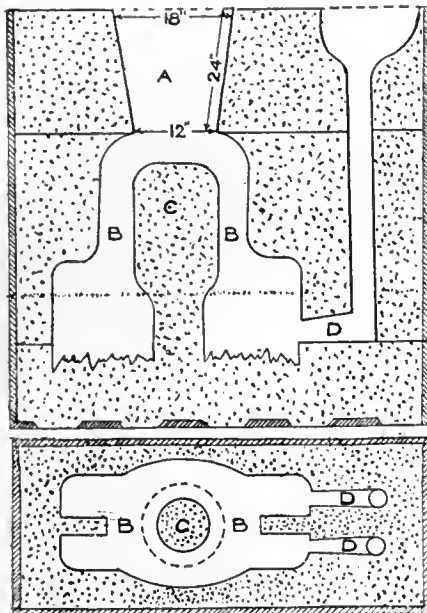

Fig. 4. The Value of Skeleton Patterns.

mission was obtained by the foundry foreman from the customer's inspector to loosen the brackets, and to have them fitted with dowel pins, but he was not

ing containing any great body of metal can be made solid. A casting solidifies on the outside, leaving the centre hollow or porous. To overcome this trouble, feeding rods are used, a riser or header being placed on the thick part of the casting and the rods worked in and out; molten metal being added from time to time to fill the void caused by shrinkage. This is the usual method adopted in dealing with most castings, but in the case of those for hydraulic work, engineers have a strong objection to the feeding rod method, and insist on the casting being fed with a large header. The effect of the header is that the casting is self-fed by pressure due to weight of metal in the header.

The section and plan is shown of a mold for a hydraulic casting of about 1,350 lbs., and illustrates the method of feeding with a larger header. (A) is the header, (B) the mold, (C) the core,



SECTION AND PLAN OF MOLD FOR HYDRAULIC CASTING.

and (D) the runner or gate. It will be observed that the casting is run from the lowest part of the mold, this being the usual procedure to obtain a clean casting. After the metal is run, it is necessary to cover that in the header with dry blacking or charecoal to insure its remaining in a fluid state until it has served the purpose of feeding the casting. Referring back to the header box, it is advisable to dry it with the mold and not make it in green sand, which is sometimes done, as this tends to chill the metal, causing it to solidify before the casting has been properly fed.

It will be found that a header less than 12 inches for a fairly large casting is useless. The cost of cutting a header off a casting is expensive, but any attempt to economise by having a narrow

neck joining the header to the casting results in the solidification of the iron in the neck. This renders useless the fluid metal in header for feeding purposes. A good mixture for hydraulic castings is: Two-thirds No. 3 brand of pig iron and one-third heavy scrap with low silicon content. This will give a close grain iron, fairly easy to machine. From "The Practical Engineer," London, Eng.

1913 FOUNDRYMEN'S CONVENTION AND EXHIBITION.

CHICAGO has been selected as the Foundrymen's Convention and Exhibition city for this year. In order to allow the greatest scope for the latter purpose, and in view of the numerous bookings of international and other exhibitions in that city this coming fall, it has been necessary to select the week of October 13. The dates selected are October 14, 15 and 16, and the Hotel La Salle has been retained as the association headquarters, the business sessions being held there also. Further announcement of the convention details will be sent out in due course.

The result of the ballot for the changes in the constitution gave 104 votes in favor of the changes recommended by the convention, and one vote in favor of every change except that relating to associate membership. Under the constitution the vote has carried.

CANADA FOUNDRIES & FORGINGS, LTD.

THE annual general meeting of the shareholders of the Canada Foundries & Forgings, Ltd., was held at the company's head office, Brockville, recently. A very favorable report for 1912 was presented. The net earnings were sufficient to provide for the preferred stock dividend and bond interest, and after making provision for bad and doubtful debts, renewals and repairs to plant, depreciation charges and 20 per cent. of organization expenses, a balance of \$25,680.33 was carried forward to the credit of profit and loss.

During the year the sum of \$63,813.85 was expended on additions to buildings and machinery, which will increase materially the producing capacity of the different plants. The demand for the various products of the company has been well maintained, the sales showing a substantial increase over those of 1911, while for the present year there is every indication of further expansion.

The recent fire at the Canada Forge Co. plant was referred to in the directors' report as not involving any loss to the company. Advantage has been

taken of the destruction of the old building to replace it by a modern steel structure of considerably larger area. Pending the completion of the new building, operations are being carried on under a temporary structure. The directors elected for the current year are as follows: E. C. Billings, Hartford, Conn.; Robert Bowie, Brockville, Ont.; John H. A. Briggs, Brockville, Ont.; Geo. P. Brophy, Ottawa, Ont.; Wm. Henry Comstock, Brockville, Ont.; John T. Dillon, Titusville, Pa.; Thomas J. Dillon, Welland, Ont.; J. Gill Gardner, Brockville, Ont.; John M. Gill, Brockville, Ont.; Hon. Geo. P. Graham, Brockville, Ont.; J. H. Houser, Toronto, Ont.; W. M. Weir, Montreal.

Mr. John M. Gill was elected president; J. H. Houser, vice-president, and H. A. Briggs, secretary-treasurer.

WILL FIGHT LEAD POISONING.

THE American Association for Labor Legislation calls attention to a warning which has been sent out by the New York State Department of Labor against lead poisoning as it exists among painters and lead workers in factories. They state that recent Federal investigation showed that this disease of plumbism is from eight to ten times as frequent in America as in European factories.

The association has a uniform bill for the regulation of the industry, which is to be introduced in the Legislature of every State of the Union. The association is conducting a campaign of education among the workers themselves, telling them that lead enters the body mainly through the nose and mouth. It may also be inhaled through the skin. As preventive measures the men are instructed always to wash before eating; never to eat in the workroom; never to chew tobacco or gum while working, because of the danger of lead mixing with the saliva; not to wear working clothes on the street or at home because of the danger to others; to use respirators; to keep the workroom clean; to eat a good breakfast before going to work, and to drink plenty of milk. The use of intoxicants in any form is proscribed. The final injunction urges the workmen to keep clean.

The Canada Carton Co., Ltd.—Incorporated at Ottawa with \$40,000 capital, to manufacture paper, paper boxes, pails, bags, cartons, etc., at London, Ont. Incorporators: Alexander Le Breton Woonton, Edouard Gordon de Wolf, Claude Brown, Edgar Hudson, Michael Patrick McDonagh, all of London, Ont.

The MacLean Pub. Co., Ltd.

(ESTABLISHED 1888.)

JOHN BAYNE MACLEAN - - - - - President
H. T. HUNTER - - - - - General Manager

PUBLISHERS OF

CANADIAN MACHINERY AND MANUFACTURING NEWS

A weekly newspaper devoted to machinery and manufacturing interests, mechanical and electrical trades, the foundry, technical progress, construction and improvement.

H. V. TYRRELL - - - - - Business Manager

PETER HAIN, M.E. - - - - - Editor
J. H. WILLIAMS - - - - - Associate Editor

OFFICES:

CANADA

Montreal, Rooms 701-702 East-
ero Townships Bank Bldg

Toronto, 143-149 University
Ave., Phone Main 7324

Winnipeg, 34 Royal Bank
Bldg., Phone Garry 2313

Vancouver, H. Hodgson 2649
Third Ave. West

GREAT BRITAIN

London, 88 Fleet Street. E.C.
Phone Central 12960
E. J. Dodd

UNITED STATES
New York, R. B. Huestis
115 Broadway, New York,
N.Y., Phone 2209 Rector

Chicago, A. H. Byrne
Room 607, Marquette Bldg.
140 S. Dearborn St., Chicago

CABLE ADDRESS:

Macpubco, Toronto. Atabek, London, Eng.

SUBSCRIPTION RATE:

Canada, \$2.00; United States, \$2.50; Great Britain, Australia and other colonies, 8s. 6d. per year; other countries, \$3.00. Advertising rates on request

Subscribers who are not receiving their paper regularly will confer a favor on us by letting us know. We should be notified at once of any change in address, giving both old and new.

Vol. IX. FEBRUARY 20, 1913 No. 5

PRINCIPAL CONTENTS.

The Application of Liquid Fuel to Foundry Practice.....	163-164
Manufacture of Locomotive Superheater Tubes	164-165
High Power Milling Features and Developments	165-166
Insulation in Refrigerating Plant and Power House.....	167-170
The Lighting of Workshops	170
The Nature and Manufacture of Shear Steel	171-172
A New Wagon Loader.....	172
A Suggested Motor Feature	172
Record Steel Output in the United States During 1912.....	173-174
Machine Shop Methods and Devices	175-176
An Interesting Relieving Attachment....Drilling Jig for Connecting Rod Brasses....Jig for Babbitting Locomotive Valve Stem Crossheads....Inserted Blade End Mills.	
Developments in Machinery	177-179
Lathe for Turning Projectiles....A Modern Forging Hammer....Six Inch Gun Cutting Machine....Combina- tion Disc Grinder and Drum Sander for Wood Pat- ternmaking.	
Foundry Practice and Equipment	180-181
The Value of Skeleton Patterns....Hydraulic Ram Castings....1913 Foundrymen's Convention and Exhi- bition....Canada Foundries & Forgings, Ltd.... Will Fight Lead Poisoning	
Editorial	182
Industrial and Construction News	183-187
The General Market Conditions and Tendencies	188-190
Selected Market Quotations	189-190
Trade Gossip....Catalogues....Calendars	190

GROUP LIFE INSURANCE FOR EMPLOYEES.

A LARGE firm of stove manufacturers in the United States has interested itself in the "welfare of its employees" to the extent of procuring "group life insurance" for each and all of them. Needless to say, this

action has been appreciated, and the general effect, of itself, gives promise of results which will be far reaching in cementing a relationship of consideration for each other's views and status. Welfare work has, up to the present been somewhat limited in its scope of application and operation, being almost entirely confined to effort on the part of large corporations. That this should be so is regrettable, for it is as operative in small as in large concerns, and what has been found to give increased returns and satisfaction in the latter, is as easy of attainment in the former. Reverting to this particular departure in "Welfare Work," viz., "Group Life Insurance of Employees," it should be noted that this particular insurance in no way influences the claim of the employees in case of death by accident, and does not interfere with any workman's liability law, since it is a death and not an accident insurance.

It occurs to us that some such arrangement would be appreciated by the employees in our Canadian factories, large and small, and that, in any case, the idea is worthy the consideration of those who rule and direct our many industrial enterprises.



OUR ADVERTISING SECTION.

MANUFACTURERS fully realize to-day the necessity and demand for advertising their product, and are backing it up by much sincerity of statement. In this they are ably supported by reputable trade journals. Advertising in these mediums is not now a catch-penny question. The page of any such paper is like a well dressed window in a departmental store, giving point to every special feature and appealing to the purse like bargain day.

We are convinced that clean advertising, concentrated as regards mediums used and extended in quantity, carries the palm as the pioneer in beating the path out from your factory door, and is the eliminator of hardship and inconvenience to the consumer. Effective and systematic advertising is more than half the battle in securing your market, and followed up by direct personal assurance from and by you or your representative in your prospective customer's sanetum instead of your own, there cannot possibly be failure in securing business.

Every doctrine of political economy and philosophy warrants us in stating that present methods do conspire to results, and that a much distorted conception of how the beings of this old world are constituted, is responsible for the theory that if a manufacturer has goods that are a necessity to the people, the latter will beat a path to the factory door to be supplied.

Consumers, generally, busy themselves with a host of questions more or less unbeneficial to their best interests, and as a consequence, lose sight of the advantages to be derived from a careful study of the advertising section of the medium which pertains directly to their requirements.

The manufacturer must make beaten paths radiate from his centre of operation to all points of the world's surface and circumference that his product is designed to reach. By display, mail, representation (local or itinerant), and advertising, must he "ancient mariner like" arrest and deliver his message to those he reckons as being needful to his service. Sitting at his desk will not avail unless he is unceasingly regulating and disseminating realistic information of what he manufactures and sells. All manner of ingenuity must be displayed, as all manner of being has to be approached. What appeals to one by sight may be unseen by another, for it is a matter of common knowledge that such blindness is widespread.

INDUSTRIAL ^A_N^D CONSTRUCTION NEWS

Establishment or Enlargement of Factories, Mills, Power Plants, Etc.; Construction of Railways, Bridges, Etc.; Municipal Undertakings; Mining News.

Engineering

FOUNDRY AND MACHINE SHOP.

Maple Creek, Sask.—The Anderson and Lee Machine Co. have opened up here in the implement business.

Port Robinson, Ont.—The Standard Steel Construction Co. will erect a 60 x 300 ft. steel plant, to cost approximately \$100,000.

Ottawa, Ont.—Fire recently did damage amounting to \$4,000 at the Ottawa Pattern and Foundry Co.'s plant, on Ottawa St.

Medicine Hat, Alta.—The city engineer has recommended the appointment of a civic blacksmith. The city has a blacksmith's shop.

Moncton, N.B.—The machine shop of J. O'Bramis and Sons was wrecked on February 11 by an explosion of gas. The loss exceeds \$7,000.

New Liskeard, Ont.—New machine shops will be opened by the Wabi Iron Works inside of three months. They will manufacture machinery required in the mining region.

Tofield, Alta.—The Tofield Foundry and Machine Co. expect to have their new plant equipped by the spring. Machinery is arriving from the east and being rapidly installed.

St. John, N.B.—The insurance carried by the McLean, Holt Foundry and the H. G. Edgewood Carriage factory which were burned on Friday, February 7, was \$2,700 and \$4,500, respectively.

Toronto, Ont.—The Canadian Car and Foundry Co. have orders on their books in excess of \$15,000,000. They recently received a large order from the C.N.R. which will keep the plant busy until September.

Belleville, Ont.—The Tivani Electric Steel Co require the following machinery for plant now in course of construction: electric motor, 2,000 volts, 2 meters, large rock crusher, 2 small compressors, cranes and drills.

Parry Sound, Ont.—The foundation for the new smelter is completed and ready for the superstructure. A quantity of steel is on the ground. The contractors for the new docks are making excellent progress.

Cobalt, Ont.—Machinery has been ordered for the mill on the Swastika

mine, and will be in operation inside of a month. The mill is designed to receive 10 stamps, but only five will be installed now, and the others when needed.

Walkerville, Ont.—George Reid will erect a garage and factory, costing \$19,000. It will be of brick, stone, concrete and steel construction, three stories 119 x 50 ft. Leybourne & Whitney, Davis Bldg., Walkerville, are the architects.

St. John, N.B.—Mr. G. Burton Stewart, managing director of the Norton Griffiths Co., Ltd., says that if the province will assist them, they will install a shipbuilding plant in St. John, in addition to their repair plant at Courtenay Bay. He spoke also of the firm establishing a steel works.

Toronto, Ont.—The owner of the Bowman Gas Range Co. plant, which was destroyed by fire on February 10, will rebuild. The damage was \$9,000. In the same fire, the plant of the Railway Equipment Co. was destroyed. This was owned by the Canadian Malleable Steel Range Co., of Oshawa. Their loss was \$16,000.

St. Thomas, Ont.—The industrial Committee with Ald. Martin as chairman are considering the offer of the steel concern to locate here. The company wants a loan and a fixed assessment, and agree to erect a \$100,000 plant, employing 150 men. They will manufacture all kinds of steel, and will take contracts for bridges and buildings.

Hamilton, Ont.—A foundry to cost \$250,000 is planned for the Hamilton Malleable Iron Co., Ltd. The main building will be 600 x 200 feet and will contain 15-ton melting furnaces, annealing furnaces, complete cleaning and finishing equipment, and high-speed electric travelling cranes. Other buildings include a machine shop, carpenter and pattern shops, storehouse, pattern storage vault and office. Cranes, compressed air molding machines and sand blast equipment are included in the requirements. J. E. Hammond is manager.

Sydney, N.S.—The Dominion Steel Corporation has made arrangements for an active business in nails in the north west. The company has bought large water front properties at Fort William, with the idea of erecting a nail mill there similar to the new mill at the Company's

plant in this city. Two 'tween deck steamers have been assigned to the service to make bi-monthly trips to the head of the lakes to carry nails, wire and other finished products. The steamers may bring grain down, or may carry ore for special mixtures.

Electrical

Caledonia, Ont.—This town has hydro-electric power now, and is looking for new industries.

Toronto, Ont.—The Ontario Hydro-electric Commission will supply Scarborough Township with power for \$2 a month plus \$30 per h.p. per year.

Peterborough, Ont.—The contract between the Hydro-electric Commission and the city will be signed this week, after which the work will proceed.

Guelph, Ont.—The Elora Council have applied to the Hydro-electric Power Commission to furnish estimate of cost for power from Guelph to Elora.

St. John, N.B.—The New Brunswick Hydro-electric Co. will make a large expenditure in connection with its project to provide another source of light, heat and power.

Calgary, Alta.—City power has been transmitted to the north-eastern section of Calgary, and will be used by the Golden West Brewery Co., the Winnipeg Oil Co., and the public abattoir.

Winnipeg, Man.—The city is planning an extension of its electrical terminal station on River Street, which will take care of the new line to Point du Bois. The station will be doubled, and will cost \$10,000.

Woodbridge, Ont.—The Woodbridge and Vaughan Independent Telephone Company were reported to be negotiating with the Bell Telephone Company for the sale of the concern. The sum asked is \$60,000.

Thorold, Ont.—The citizens are strongly in favor of Hydro power, and will ask that the Ontario Hydro-electric Commission consider the establishment of a municipally-owned plant here. It is understood that Allanburg and Fonthill would become customers.

Ottawa, Ont.—Transformers, meters and general electrical supplies are required by the city council. Tenders will be called in about two weeks. Legislation will be asked to allow city to issue debentures for \$150,000 for changing present electric plant from two-phase to three-phase.

Motor Car Industry

Vancouver, B.C.—The Beaver Automobile Co., Portland, Ore., which was recently incorporated with a capital of \$150,000, contemplates the erection of a plant here for the manufacture of automobiles.

Moose Jaw, Sask.—The Canadian Standard Automobile and Traction Co., Ltd., will begin delivering motors in less than a month. The firm will make a six-cylinder car with nickle trimmings and aluminum running board. The heating plant will be installed in a few weeks.

General Industrial

Montreal, Que.—An ink factory for the Carter's Ink Co. is being planned.

Sarnia, Ont.—A gate factory to cost \$8,000 for the Regal Gate Co. will be built.

Oil Springs, Ont.—One flax mill here has been started up again with a full force of men.

Montreal, Que.—The extension to factory, to cost \$8,000, for Liquid Air Co., will be made.

Winnipeg, Man.—The T. Eaton Co., Ltd., will build a three-storey addition to their present factory.

Berlin, Ont.—A clock factory on Frederick Street is contemplated by the Arthur Pequet Clock Co.

Montreal, Que.—A fire did \$50,000 damage to the factory of the Canadian Ribbon Co. on February 13.

St. Thomas, Ont.—Thomas Bros., Mfg. Co. will build a factory costing \$30,000 to manufacture brushes, brooms, etc.

Montmorency, Que.—An extension to the factory for Dom. Textile Co., is planned, to contain 1,200 new looms.

Saskatoon, Sask.—A tile factory is planned for the S. & S. Non-breakable Hollow Building Tile Co. for next spring.

Belleville, Ont.—The Gilmour Door Co. have sold land to the Canadian Creosoting Co., who will probably erect a \$200,000 plant.

Calgary, Alta.—The plant of P. Burns Company, meat packers, will be rebuilt

outside of Calgary, in a new section to be called 'Burns.'

Galt, Ont.—S. L. Clark will erect a creamery in the spring. The building will be of brick or concrete construction, with concrete and tile floors.

Trenton, Ont.—The Canadian Pearl Button Co. have been re-organized with an enlarged capital. The firm will now be able to extend its plant.

St. Henri, Que.—A factory will be built for the Alaska Feather & Down Co., 412 St. Ambroise Street, two storeys high, and of brick construction.

Trenton, Ont.—The Canadian Creosoting Co. have been granted concessions by the council, and will build a \$250,000 plant here, employing 100 men.

Tavistock, Ont.—Senator Valentine Ratz plans the erection of a felt boot factory. The building will be of white brick, two storeys, 60x75 ft., and is estimated to cost \$15,000.

Halifax, N.B.—The plant of the North Atlantic Fisheries Co. at Port Hawkesbury was completely destroyed by fire on February 12. The insurance on the plant amounts to \$212,000.

Medicine Hat, Alta.—The mill and elevator of the Redeliff Milling and Elevator Co., at Redcliffe, Alta., were destroyed by fire on Saturday, February 8. The loss, including wheat, is \$50,000.

Hamilton, Ont.—The Eagle Mills, Ltd., a company recently incorporated at Ottawa, will probably erect a knitting mill this year. Another company is also planning a knitting mill. Penmans of Paris are interested.

New Westminster, B.C.—The B.C. Transport Co. will erect a large brick plant. The kilns will be equipped with an oil burning and heating plant, and the machinery operated by water power. Mr. T. H. Pearson is the manager.

Montreal, Que.—The Smart-Woods Co. plan alterations and additions to their bag factory on Mullins Street. It will be three storeys, of reinforced concrete, brick and mill construction. Ross & McDonald, 1 Belmont Street, are the architects.

Prince Rupert, B.C.—The Northern Brick and Tile Co., Ltd., is the name of a company that has recently been incorporated for the manufacture of brick for the Prince Rupert market. The company is made up entirely of local men.

Hamilton, Ont.—The Board of Control have not yet agreed to the amalgamation of the Hamilton Gas Light Company and the Ontario Pipe Line Co. Only on this condition will the United Gas and Coke Company establish their plant here.

Burlington, Ont.—The Vera Chemical Co. will erect a size factory of four storeys, 152 x 62 ft. Boilers, engines, belting, 70-ft. stacks, will be required. Gladman & Gladman, Confederation Life Bldg., Toronto, Canada, are the architects. D. C. Davis is superintendent of the company.

Stratford, Ont.—Ratepayers on March 10 will vote on two by-laws, to make concessions to the Farquharson-Gifford Co. if they erect a \$30,000 factory for upholstered furniture, and to treat the R. F. Kastner Company similarly for the manufacture of leather mills, gloves and fur coats.

Peterborough, Ont.—Part of the De Laval Dairy Supply Co.'s plant is complete. The power house has one 125 h.p. boiler, and another will be added when the rest of the factory is completed. Plans call for other buildings of six and seven units, each unit being 112x100 feet. Mr. Ralph Stoddart is the president.

London, Ont.—The company which bought the Wilcox plant in Chelsea Green will be known as the Richards-Wilcox Mfg. Co. Mr. Wm. R. Yendall is the general manager. A start will be made on the manufacture of door-hangers and overhead carrying systems this month. Immediate extensions are to be made.

Montreal, Que.—Mr. R. J. Tooke, head of the well-known shirt and collar firm, has decided to retire, and arrangements have been made whereby the Semi-Ready, Ltd., will acquire the factory, stores and other premises of R. J. Tooke, Ltd., with a capital stock of \$300,000. It is the intention of the new owners to extend the operation of the Tooke Company throughout Canada.

Municipal

Chatham, Ont.—The City Council plan to instal a hydro-electric system. Mayor A. J. Dunn.

Montreal, Que.—The Board of Commissioners require 8,130 tons of cast iron water pipes.

Tilbury, Ont.—The Town Council will instal a hydro-electric system. The clerk is W. A. Hunter.

Regina, Sask.—This city will spend \$15,000 on a plant to make gas from coal for domestic purposes.

Transcona, Man.—The owners of 50 acres of land will offer it to bona-fide manufacturers at a nominal figure.

Kerrobert, Sask.—The Town Council plan to purchase fire fighting apparatus this year. The clerk is O. H. Anderson.

Teeswater, Ont.—Power machinery is required by the County Council for the development of power on the Saugeen River.

St. John N.B.—The public works now under way in this city and the immediate vicinity involve an expenditure of \$45,000,000.

Transcona, Man.—The Fire, Health and License Committee will advertise for a double cylinder chemical engine for Ward 4.

Medicine Hat, Alta.—The ambulance arrangement is so unsatisfactory here, the city is considering the purchase of a motor ambulance.

Nanimo, B.C.—The ratepayers will shortly be asked to vote on a by-law whereby \$25,000 will be raised for purchase of auto propelled fire apparatus.

Kingsville, Ont.—A by-law will be submitted March 3 whereby \$10,000 will be raised as a loan to the Dominion Stove Company for the erection of a factory here.

Guelph, Ont.—The city have fixed taxation of the Page-Hersey Co. at \$15,000 for the next ten years. Work will commence at once on the firm's new \$40,000 plant.

Bassano, Alta.—The town will submit a by-law to the people on February 21 authorizing them to borrow \$8,000, for the construction of plank sidewalks, and the erection of a town hall.

Portage La Prairie, Man.—A by-law will shortly be submitted to the ratepayers whereby the sum of \$35,000 will be raised to cover cost of building bridges at High Bluff and Westbourne.

Yorkton, Sask.—The burgesses will vote on a by-law to raise \$75,000 for the purpose of extending the present electric system, and to raise \$18,000 to cover cost of improving present waterworks system.

Springbank, Ont.—The city of London plans changing old pump house to power house; three large electric generators will be operated by power from River Thames, to work in conjunction with hydro-electric power.

Railways—Bridges

Hamilton, Ont.—The Hamilton Street Railway Co. are planning a five mile extension in the east end.

London, Ont.—The London Street Railway plan double tracking in several parts of the city.

Chatham, Ont.—Three bridges are planned by the City Council, of steel and cement construction.

Toronto, Ont.—C.N.O. Railway Co. have been authorized to construct four bridges.

Estevan, Sask.—The G.T.P. will build a branch line into Estevan from the line now being built from Regina to North Gate.

Vancouver.—It is proposed to expend \$2,250,000 on good roads in the neighborhood. The provincial government will be asked for assistance.

Winnipeg, Man.—The Lake Winnipeg and Nelson River Railway Co. will apply for charter for railroad from upper end of Lake Winnipeg.

Kingston, Ont.—Kingston sent a delegation to urge upon the G.T.R. the advisability of running its line farther into the city than at present.

Toronto, Ont.—The Strachan Ave. bridges over the G.T.R. and the Queen's wharf spur on the C.P.R. are to be reconstructed four feet higher.

Brandon, Man.—The Brandon Street Railway System will be extended as far as the Dominion Experimental farms. The clerk is H. W. Brown.

Lethbridge, Alta.—The C.P.R. line to be built by the Alberta Railway and Irrigation Co. will probably pass through Pincher Creek and Cardston, Alta.

Ottawa, Ont.—The Superior Rolling Stock Co., Ltd., has made a conditional sale of a large amount of rolling stock to the Algoma Central & Hudson Bay Railway Co.

St. Boniface, Man.—Tenders will be received up to Monday, February 17, for the substructure of the Provencher Bridge, across the Red River, J. B. Cite is city clerk.

Toronto, Ont.—The Scarborough Township Council have asked the Railway Commission to order the C.P.R. to erect a bridge over their lines between Scarborough and Pickering Townships.

London, Ont.—It is said that \$400,000 worth of bonds, or a controlling interest in the Chatham, Wallaceburg and Lake Erie Railway have been acquired by the Mackenzie-Mann interests.

Fredericton, N.B.—When opening the legislature last week, the Lieut-Governor announced that work on the St. John Valley Railway and the Fredericton Grand Lake Railway was being pushed forward.

Hamilton, Ont.—The T. H. & B. Railway will probably elevate their tracks to improve Hunter Street at a cost of \$760,570. To depress them, it is estimated that the cost would be over \$3,000,000.

Toronto, Ont.—The new Gerrard St. bridge, costing \$200,000, will be 60 ft. wide. The type will be deck plate girder approach spans. Plans have recently been approved by the civic works committee.

Stratford, Ont.—A by-law will be submitted to the people on March 10 granting the C.P.R. right of way along the south shore, for its Embro to Linwood line. If the by-laws passes, the Duffton Woollen Mills will be removed.

Parry Sound, Ont.—The Canadian Northern Railway Co. has been authorized to extend spurs to the Canada Chemical Co.'s smelter, and to the iron and ore bins and charcoal plant of the Standard Iron & Lumber Co. of Canada, Ltd.

Ottawa, Ont.—Two years more has been given for the completion of the lines of the Niagara, St. Catharines and Toronto Railway. The lines authorized are from Port Colborne to Port Erie and Niagara Falls and thence through Welland, St. Catharines and Hamilton to Toronto.

Vancouver, B.C.—In connection with the installation of oil burning locomotives to run between Vancouver and North Bend, the C.P.R. will erect oil tanks at Port Moody, Coquitlam, Mission Junction, Ruby Creek and North Bend. The oil will be brought to Port Moody and Vancouver by ocean vessels, and will be pumped from Port Moody to Coquitlam.

Montreal, Que.—The new roundhouse which is being constructed for the G.T.R. by the John S. Metcalfe Co., at St. Lambert, Que., is rapidly approaching completion, and will furnish accommodation for housing and repairing 27 locomotives of the largest type. The structure comprises roundhouse, machine shop, boiler house, fan house, office and stores and casting store.

Wood-Working

Elmira, Ont.—The Elmira Furniture Company are preparing to build a large addition to their factory.

Minaki, Ont.—A saw mill is planned for next fall for The Crossing Lumber Co. Managing director Frank R. Patriarche.

Sidney, B.C.—A new engine and dynamo arrived last week for the Canadian Southern Lumber Co., to be used in their large mill.

Hamilton, Ont.—On February 13, a fire destroyed much machinery and lumber in a planing mill, owned by J. J. Smith & Sons.

Montreal, Que.—Fire did \$3,000 damage to the saw mill of William Rutherford & Sons, Limited, on February 10, at 425 Atwater Avenue.

Guelph, Ont.—The Robert Stewart Company, who operate planing mills and kindred works at Guelph, Ont., are expected to erect a new factory in the near future.

White Rock, B.C.—A sash and door factory and lumber mill is to be erected here in time for this season's building operations. Work will commence on it this month.

Edmonton, Alta.—The Upper Frazer River Lumber Co., of Montreal, has started work on a large saw mill at Bar Creek, which will employ over 200 men in the mill and 400 cutting timber. A. H. Edwards, Alberta Hotel, represents the company here.

Fredericton, N.B.—Galvanized iron roofing, metal lath, electric light and fire equipment, planing mill machinery, extensive piping connections, belting and sprinkler system will be required for the rebuilding of the Fraser lumber mills.

Building Notes

Welland, Ont.—The Methodist Church will build a Sunday School to cost \$10,000.

Amherst, N.S.—This city is to have a \$50,000 armory on condition that a site is given free.

Toronto, Ont.—The Township of Scarboro' will borrow \$18,000 for the erection of two schools.

St. Catharines, Ont.—Warren Bros. have been granted a permit for a \$10,000 addition to their factory.

Moose Jaw, Sask.—A \$250,000 permit is in now for the proposed Maitland Hotel, plans for which are ready.

Dunmore, Alta.—A Seattle firm will erect a \$50,000 hotel here. Building material has been ordered in Medicine Hat.

Ingersoll, Ont.—Nagle & Mills have been awarded the contract to build a convent here of red brick, faced with stone.

Vancouver, B.C.—The contract for the Y.M.C.A. has been let to Booker, Campbell & Whipple, Ltd., at a cost of \$340,270.

St. John, N.B.—Work on the new C.P.R. elevator is progressing. The forms for the concrete foundations are being set up.

Regina, Sask.—A six-storey warehouse, 120x120 feet, to cost \$215,000, is

planned for the John Deere Plow Co., Regina, Sask.

Victoria, B.C.—Weiler Bros., house furnishers, will erect a half million dollar ten-storey structure as soon as the plans are completed.

Toronto, Ont.—The Board of Education will build a \$280,000 High School of Commerce and Finance. It will contain an assembly hall for 1,000 persons.

Walkerton, Ont.—The contract for building a pier for Southampton bridge has been given to the Hunter Bridge and Boiler Co., at \$10,000, their tender being the lowest.

Revelstoke, B.C.—Tenders are being asked for the construction of the Odd-fellow's block at an estimated cost of \$18,500. It will be two storeys high with a basement.

London, Ont.—It is reported that English's, Ltd., real estate agents, Toronto, have asked for an option on the Speneer block at \$90,000, and that a million dollar hotel will be erected.

Montreal, Que.—Messrs. Ross and McDonald, architects, are busy preparing plans for a \$1,000,000 hotel to be built on the site of St. George's Church, Dominion Square. These provide for 600 rooms. The church have two years in which to vacate the premises.

Victoria, B. C.—Tenders are asked by the provincial government for the construction of the new normal school, at an approximate cost of \$250,000. The frame will be of reinforced concrete. There will be a woodworking room and a forge in connection with the school.

Vancouver, B.C.—The contract for building the Hudson's Bay Co. store has been let to Messrs. Romke, McDonald & Moneriff, a local firm. It will be 10 storeys high, with two basement floors. The construction will be of steel and reinforced concrete. The mechanical plant has been designed by Mr. Percival R. Ross, of New York. The building will have its own heating, lighting and refrigerating plants. It should be ready for occupancy by Christmas.

Toronto, Ont.—The new technical school will cost \$1,325,205 for building, \$250,000 for site, and with extras will total \$2,000,000. The accepted tenders were: Norcross Bros., building, \$1,082,700; General Fire Extinguisher Co., heating and ventilation, \$148,900; Fred. Armstrong Co., plumbing, \$42,600; Turnbull Elevator Co., elevators \$6,005; Estimate for wiring \$45,000. The building will be of Credit Valley stone, with Indiana red stone trimmings. It will take two years to erect.

Refrigeration

Regina, Sask.—Hugh Armour & Co. are having their branch meat house at Regina equipped with a 25-ton "York" refrigerating plant.

Toronto, Ont.—T. Eaton Co., Ltd., are adding to the refrigerating plant in their department store a 4-ton "York" refrigerating machine.

Toronto, Ont.—The Toronto General Hospital is being equipped with a 17-ton "York" refrigerating plant and small ice making system. Installation is by the Kent Co., Ltd., Montreal.

Toronto, Ont.—Indications are that it will be at least a year before Toronto gets the new civic abattoir in operation. There has been considerable delay in preparation of plans, and there is little money available for the work.

Charlottetown, P.E.I.—The Island Cold Storage Co., Ltd., has had its refrigerating plant improved by addition of a 30-ton horizontal double acting "York" refrigerating machine, installed by the Kent Co., Ltd., Montreal.

Ottawa, Ont.—The Ottawa Artificial Ice Co. have let contracts to the Triumph Ice Machine Co., Cincinnati, O., for machinery and apparatus for a 50-ton ice making system and for an additional 10-ton refrigerating system for bottling works. The plant is to be electrically driven and equipped with multiple-effect evaporators for supplying distilled water.

Marine

Coquitlam, B.C.—The C.P.R. will probably establish elevators on the Pitt and Frazer Rivers here.

Port Colborne, Ont.—The government elevator here will have its capacity increased from 750,000 to 2,000,000 bushels.

Le Pas, Man.—The Dominion Government Department of Public Works will spend \$50,000 in dredging the Pas River and building suitable docks, etc.

Revelstoke, B.C.—The Dominion Government is building a new wharf on the Columbia River, 260 feet long and 36 feet wide. The estimated cost is \$10,000.

Collingwood, Ont.—At the annual meeting of the Farrar Transportation Co. it was practically determined that a new 12,000 ton steamer should be built.

Vancouver, B.C.—A halibut schooner was launched last week for the Canadian Fish and Cold Storage Co., at the Vancouver Shipyards. The company will increase its fleet from five to ten shortly.

Sault Ste. Marie, Ont.—The towns of Southampton, Port Elgin and Kincardine, have asked the Federal Government to subsidize a regular steamship service between Southampton and Sault Ste. Marie; also for an appropriation for a breakwater and dredging at Southampton. The government has promised sympathetic consideration.

Personal

C. R. Ross, who was formerly electrical engineer of the Winnipeg Street Railway, is in charge of the development of Dunmore, Alta.

James G. Lindsay, engineer and waterworks manager for the city of Belleville, Ont., since April, 1910, has resigned. He will relinquish his duties February 24.

George Ross, P.L.S., has been appointed Welland county engineer, at a salary of \$8 per day while engaged, and **James McKeown**, of Willoughby, superintendent of highways, at a salary of \$1,100 per annum.

Tenders

Sutherland, Sask.—Tenders are asked up to February 24 for 8,650 ft. of 12-inch steel pipe; 9,775 ft. of 10-inch; 4,000 ft. 8-in., and 18,800 ft. of 6-in. steel or cast iron pipe for waterworks and sewer systems.

Hamilton, Ont.—Tenders are called for 12-inch high pressure flanged pipe; 12-inch bell and spigot pipe, high pressure; 12-inch, 16-inch and 24-inch special castings for high and low pressure service. Address tenders to Mayor Allen.

Newcastle, N.B.—Tenders are asked for a concrete and steel bridge 2,727 feet long, four truss spans, and a swing draw. Some of the piers are to be built in 41 feet of water and 24 feet of mud. The estimated cost is \$300,000.

Toronto, Ont.—Tenders will be received by registered post only, addressed to the Chairman of the Board of Control, up to noon on Tuesday, March 4, 1913, for 24-inch and 30-inch, 36-inch (a), 36-inch (b), and 42-inch cast iron pipes.

Toronto, Ont.—The Hydro-electric Power Commission is calling for tenders for galvanized steel towers, copper and aluminum cable, insulators, galvanized malleable iron and galvanized pressed steel elamps, for the construction of 125 miles of transmission line to operate at 110,000 volts.

Sarnia, Ont.—Tenders will be received up to March 15 for waterworks construction. These include:—Furnishing

cast-iron or steel water pipes and special castings; gate valves, flexible joints, expansion joints, etc.; furnishing and erecting pumping machinery and accessories; furnishing and erecting boilers.

Vancouver, B.C.—Tenders are invited for: 5,280 lin. ft. of 2-in. gal. iron pipe with unions; 5,280 lin. ft. of 4-in. No. 8 lapwelded or weldless steel pipe; 107,000 lin. ft. of 6-in. No. 9 lapwelded or weldless steel pipe; 50,000 lin. ft. of 8-in. No. 7 lapwelded or weldless steel pipe. These should reach City Purchasing Agent, City Hall, before March 5.

Toronto, Ont.—The Controllers have decided to give the preference to the John Inglis Co., Toronto, in awarding the contract for water tube boilers for the main pumping station. Works Commissioner Harris had recommended the tender of the Babcock & Wilcox Company, a Scotch-made boiler. The Inglis tender did not comply with the specifications, but Mr. Harris said it would be satisfactory, and the difference in cost is small.

Dalhousie, N.B.—Sealed tenders will be received by the Town Clerk until 8 p.m., Wednesday, March 5, 1913, for the following works:—

Contract B—Power house.

Contract G—Booster pump: (1) steam pump, (2) turbine pump.

Contract H—Two boilers.

Contract J—Electric light engines: (1) High speed steam engine, (2) Gas engine and gas producers, (3) Diesel oil engine, (4) Crude oil engine.

Contract K—Electrical equipment and distribution system.

Plans and specifications may be seen on and after February 10th at the office of the Chief Engineers, Mail Building, Toronto, or at Dalhousie, N.B. W. S. Montgomery, Mayor; Alex. J. Le Blanc, town clerk; Chipman & Power, engineers.

Bowmanville, Ont.—Tenders for the following will be received by the town clerk until Wednesday, March 19:—

Contract A1—Laying water mains in town.

A 2—Laying sewer pipes.

B—Constructing pump house.

C—Constructing three reservoirs.

D—Furnishing iron piping.

E—Furnishing hydrants, valve, etc.

G—Furnishing electrically operated booster pump.

M—Laying 8 miles of gravity conduit.

S—Furnishing sewer pipes.

X—Constructing sewage disposal works. Chipman & Power, Mail building, Toronto, are the engineers.

Toronto, Ont.—Tenders for the steel superstructure of St. Clair Avenue

bridge will be received by the Chairman of the Board of Control up to noon, March 11. Specification and tender form from Railway and Bridges Section, Department of Works, City Hall.

Toronto, Ont.—Tenders will be received by registered post only addressed to the Chairman of the Board of Control, City Hall, Toronto, up to noon on Tuesday, March 4th, 1913, for:

Concrete Mixers.

Grading Machines.

Tar Kettles.

Road Rollers, 3-wheel.

Road Roller, tandem.

Searifiers.

Stone Crushing Outfit, complete (stationary).

Centrifugal Pumps, portable, with boilers, mounted.

Boilers Mounted.

Hoisting Engines and Boilers.

Derricks.

Clams.

Buckets.

Excavating Machine, complete.

Diaphragm Pumps and Hose.

Inspection Rods.

Specification and tender form may be obtained upon application at the office of the Purchasing Section, Department of Works, City Hall, Toronto.

Obituary

William Risdon, of St. Thomas, Ont., who founded the Erie Iron Works in 1895, died on Wednesday, February 12, aged 75. For many years he was in the hardware business in St. Thomas.

George Wm. Maynard, mining engineer, who introduced the Thomas basic steel process into the United States, died in Boston, February 13. He was one of the original members of the American Institute of Mining Engineers.

Trade Gossip

The A. G. Brown, Jamison Co., Ltd., of Vancouver, dealers in machinery, contractors' equipment and foundry supplies, announce that the name of the firm has been changed to E. P. Jamison & Co., Ltd.

The Bury Compressor Co., Erie, Pa., recently installed one of their variable volume air compressors in the plant of The North American Smelting Co., Sydney, Ont., and another of the same style of compressor, but of the Duplex type, in the plant of The Standard Steel Construction Co., Port Robinson, Ont.

The General Market Conditions and Tendencies

This section sets forth the views and observations of men qualified to judge the outlook and with whom we are in close touch through provincial correspondents.

St. John, N.B., Feb. 17.—About fifty men were put to work last week in this city on the site of the new sugar refinery to be built here by the Atlantic Sugar Refineries Ltd. Mr. L. R. Wilson, who has opened up offices in the capacity of treasurer and manager, is taking charge of the operations now under way, and in a few days it is planned to materially increase the present staff. The refinery when completed will be one of the most up-to-date of its kind in Canada or New England, and the seven buildings to be erected for its operations will be a valuable addition to the industrial plants of this city. All the buildings with the exception of the warehouse are to be of fireproof construction, with steel beams and columns with brick enclosure, and partition walls also of brick. The pan and melter houses and machine shop will be constructed of extra fireproof material consisting of two inches of cinder concrete or hollow tile. The floor construction in the different buildings is to be of reinforced concrete slabs on top of steel girders. The floor coverings are to be of granolithic cement, asphalt, or maple, depending on what is considered the better adapted to the different structures or departments. Electric elevators and modern sanitary fixtures will be installed and the whole suite of buildings will be thoroughly up-to-date in every respect. When completed, the refinery will have an output of 2,000 barrels a day and will afford employment to about 700 men. It is estimated that from 150 to 200 tons of coal a day will be required to operate the plant.

R. E. Chadwick, manager of Foundation Co., Ltd., for Eastern Canada, was in the city this week, and said that the work of excavating would be pushed with all possible rapidity, and that very soon about 300 men would be employed in this connection working night and day in two or more shifts. In a few days the contracting plant will arrive in the city and a start will be made on sinking the 107 caissons to be used. It is thought that in about three months, the foundation work will be completed, and there is the possibility that before then the steel work on the building will be in course of erection. The site chosen for this gigantic project is a splendid one and the dock facilities provided are expected to prove of distinct value, permitting even the largest of sea-going

steamers to moor at the wharves on which the buildings will border.

Mr. Stanley Elkin, of the Maritime Nail Co., St. John, has returned after a trip to Europe which he undertook in the interests of his firm. He was away about two months. He said that at present he was not prepared to divulge any arrangements which had been made or the precise nature of his visit to the Old Country, but he could say definitely that there would be considerable local extension to the present plant, requiring a heavy financial expenditure. More machinery was to be installed, and provision made for increasing the output, which at present is looked upon as particularly large. He also said that his company intended to make a start sometime soon on a new nail factory at Fort William, Ont., finding splendid opportunities for business in that neighborhood and in the surrounding western territory. He was pleased to note that the City Council of Fort William had guaranteed the sum of \$250,000 in bonds, a circumstance that was most encouraging to the enterprise.

The T. S. Simms building in Union Street, has been taken over by the Ganong Bros., candy manufacturers of St. Stephen, and work in the new factory will soon be under way with W. K. Ganong, general manager, and Fred Loekery, head of the manufacturing department. The company will operate under a different name, and will run the plant separately from that in St. Stephen. Mr. Ganong, who was in the city last week, said that there were great possibilities before the concern, and the business amounting to \$850,000 which was done last year, he hoped to see increased to the million dollar mark this year. In the new St. John factory there will be installed machinery valued at \$20,000, part of which is already on its way here. About seventy hands will be soon employed, and early in the fall fully 150 will be at work. If everything goes well, there will be 250 men employed next year.

The machine shop conducted in Moncton, N.B., by John Abrams & Sons was completely wrecked this week by an explosion which occurred about 1 o'clock in the morning. The boiler blew up shattering the walls of the building, and blew off the roof, practically demolishing the structure, which for work purposes will have to be rebuilt.

Toronto, Ont., Feb. 18.—Several of the big machinery and supply houses in Toronto found business only fair last week. A. R. Williams & Co. secured the order of the Toronto Structural Steel Co. for punches, plate rolls, etc., which company, as reported in Canadian Machinery two weeks ago, was incorporated at Ottawa with a million dollars' capital. Besides the above, the A. R. Williams Co. secured the entire equipment for the new structural steel works at Napanee, Ont., which included boiler plate rolls, punches and shears. The Great Western Iron and Chemical Co., of Prince Albert, Sask., who recently had representatives in the city buying heavily of machinery, also placed their order with A. R. Williams & Co. This has now been filled.

Pig Iron.

Canadian pig iron furnaces show a good week of business. Drummond, McCall & Co., who have a furnace at Midland, sold a considerable quantity of pig iron, scattered over a number of purchasers. There were no really big orders, however. Their manager in Toronto sees no symptoms yet of the price dropping, and their product, f.o.b. Midland, remains at \$21 for Nos. 1 and 2. Canadian manufacturers are not buying pig or steel beyond their immediate needs, claiming that the price is too high, and expressing their firm conviction that a drop must take place before long. Some English pig iron is being brought to this country for consumption in the Province of Quebec, but very little is being bought in or around this city, the price being too high.

Plates, Tubes, Structural Steel.

This is not the time of the year for big purchases of structural steel. Big buyers all had their contracts laid months ago, and specifications are now coming in for spring delivery. There is, however, a good steady demand for small quantities. A large American steel concern, with offices in the city, has reduced the price of its small shapes from 2.5c to 2.4c per lb. Inquiries for warehouse import are strong. There is a heavy demand for boiler tubes, mainly for repair work. The steamship lines, with early opening of navigation in sight, are all overhauling and repairing.

Sheets and Bars.

This is an off season for sheets, as the stove manufacturers are doing little buying, most of them being covered for the first half of the year. Specifications, however, are coming in in advance of contracts, and prices are firm. American mills are booked up for the first half of the year with orders, and some even into the third quarter. Specifications should, therefore, be in early. The same

(Continued on page 190.)

SELECTED MARKET QUOTATIONS

Being a record of prices current on raw and finished material entering into the manufacture of mechanical and general engineering products.

PIG IRON.		Per Ton.
Foundry No. 1 and 2, f.o.b., Midland	\$21 00
Gray Forge, Pittsburgh	17 15
Lake Superior, charcoal, Chicago	18 00
		Mont'l. Tor'to.
Canadian f'dry, No. 1	22 50
Canadian f'dry, No. 2	22 00
Middlesboro, No. 3	21 00
Summerlee, No. 2	24 00
Carron, special	23 50
Carron, soft	23 00
Cleveland, No. 1	22 00
Clarence, No. 3	22 50
Jarrow	25 50
Glengarnock	26 00
Radnor, charcoal iron	33 75
Ferro Nickel pig iron (Soo)	25 00

BILLETS.

	Per Gross Ton.
Bessemer billets, Pittsburgh	... \$29 00
Open hearth billets, Pittsburgh	... 30 00
Forging billets, Pittsburgh	... 36 00
Wire rods, Pittsburgh	... 30 00

FINISHED IRON AND STEEL.

Per pound to large buyers:

	Cents.
Common bar iron, f.o.b., Toronto	.. 2.10
Steel bars, f.o.b., Toronto 2.20
Bessemer rails, heavy, at mill	... 1.25
Iron bars, Pittsburgh 1.70
Steel bars, Pittsburg, future 1.45
Tank plates, Pittsburgh, future	... 1.50
Tank plates, New York, future	... 1.61
Beams, Pittsburgh, future 1.50
Angles, Pittsburgh, future 1.50
Steel hoops, Pittsburgh 1.60

Toronto Warehouse f.o.b., Toronto.

	Cents.
Steel bars 2.30
Small shapes 2.40
Warehouse import, freight and duty to pay:	
Steel bars 1.95
Structural shapes 2.05
Plates 2.15

Freight, Pittsburgh to Toronto:

18 cents carload; 21 cents less carload.

BOILER PLATES.

	Mont'l. Tor'to.
Plates, 1/4 to 1/2-in., 100 lbs.	\$2.40 \$2.40
Heads, per 100 lbs.	2.85 2.95
Tank plates, 3-16 in.	2.60 2.60
Tubes, per 100 ft., 1 inch	8.50 8.50
" " 1 1/4 in.	8.50 8.50
" " 1 1/2 "	9.00 9.00
" " 1 3/4 "	9.00 9.00
" " 2 "	8.50 8.50
" " 2 1/2 "	10.50 10.50
" " 3 "	11.50 11.50
" " 3 1/4 "	13.25 13.25
" " 3 1/2 "	14.50 14.50
" " 4 "	18.00 18.00

BOLTS, NUTS AND SCREWS.

	Per cent.
Stove bolts	80 & 7 1/2
Machine bolts, 3/8 and less	65 & 5
Machine bolts, 7-16	57 1/2
Blank bolts	57 1/2
Bolt ends	57 1/2
Machine screws, iron, brass	35 p c.
Nuts, square, all sizes	4c per lb off
Nuts, Hexagon, all sizes	4 1/4 per lb off
Flat and round head	35 per cent.
Fillister head	25 per cent.
Iron rivets	60, 10, -0 off
Wood screws, flathead, bright	85, 10, 7 1/2 p c off
Wood screws, flathead, brass	75, 10, 7 1/2 p c off
Wood screws, flathead bronze	70, 10, 7 1/2 p c off

WROUGHT IRON PIPE.

The following are Toronto jobbers' discounts on pipe. (Card weight) in effect from October 11th, 1912:

	Standard		Buttweld		Lapweld	
	Black	Gal.	Black	Gal.	Black	Gal.
1/4 3/8 in.	63	48
1/2 in.	68	58
3/4 to 1 1/2	72 1/2	62 1/2
2 in.	72 1/2	62 1/2	69 1/2	59 1/2
2 1/2 to 4 in.	72 1/2	62 1/2	71 1/2	61 1/2
4 1/2 to 6 in.	72	62
7, 8, 10 in.	66 1/2	54 1/2

X Strong P. E.

1/4, 3/8, 1/2 in.	64	54
3/4 to 2 in.	68	58
2 1/2 to 3 in.	68	58
3 1/2 to 4 in.	65	55
4 1/2 to 6 in.	63 1/2	56 1/2
7 to 8 in.	56 1/2	46 1/2

XX Strong P. E.

1/2 to 2 in.	43	33
2 1/2 to 4 in.	43	33

IRON PIPE FITTINGS.

Canadian malleable, 40 per cent.; cast iron, 65; standard bushings, 70; headers, 60; flanged unions, 65; malleable bushings, 65; nipples, 75; malleable, lipped unions, 65.

COKE AND COAL.

Solvay Furnace Coke	\$5.25
Solvay Foundry Coke	6.50
Connellsville Furnace Coke	5.75
Connellsville Foundry Coke	6.25
Yongh. Steam Lump Coal	3.75
Penn. Steam Lump Coal	3.63
Best Slack	2.95
All net ton f.o.b. Toronto.		

OLD MATERIAL.

Copper, light	\$11.00 to 11.50
Copper, crucible	14.00 to 14.50
Copper, unrec'bled, heavy	12.00 to 12.50
copper wire, unrec'bled	12.00 to 12.50
No. 1 machine compos'n	11.00 to 11.50
No. 1 comps'n turnings	10.00
New brass clippings	9.00 to 10.00
No. 1 brass turnings	7.50 to 8.00
Heavy lead	3.25 to 3.50
Tea lead	3.50 to 3.60
Serap zinc	3.50
Toronto dealers' purchasing prices.		

SMOOTH STEEL WIRE.

No. 6-9 gauge, \$2.35 base; No. 10 gauge, 6c extra; No. 11 gauge, 12 extra; No. 12 gauge, 20c extra; No. 13 gauge, 30c extra; No. 14 gauge, 40c extra; No. 15 gauge, 55c extra; No. 16 gauge, 70c extra. Add 60c for coppering and \$2 for tinning.

Extra net per 100 lb.—Spring wire; bright soft drawn, 15c; charcoal (extra quality), \$1.25.

METALS.

Prices per pound to largest buyers:

	Cents.
Lake copper, Toronto \$15.75
Electric copper, Toronto 15.75
Spelter, Toronto 5.75
Lead, Toronto 4.20
Tin, Toronto 50.00
Antimony, Hallet, Toronto 9.50
Aluminum, Toronto 22.00

SHEETS.

		Mont'l. Tor'to.
Sheets, black, No. 2S....	\$2 80	\$3 00
Canada plates, ordinary,		
52 sheets	2 90	3 00
Canada plates, all bright.	3 70	4 15
Apollo brand, 10¾ oz.		
(American)	4 30	4 20
Queen's Head, B.W.G....	4 45
Fleur-de-Lis, 2S.....	4 15

NAILS AND SPIKES.

Standard steel wire nails,		
base	\$2 40	
Cut nails	\$2 55	2 65
Miscellaneous wire nails..	75 per cent.	

Pressed spikes, 5/8 diam.,
100 lbs. 2 85

FINE STEEL WIRE.

Discount 25 per cent. List of extras.
In 100-lb. lots: No. 17, \$5; No. 18, \$5.50; No. 19, \$6; No. 20, \$6.65; No. 21, \$7; No. 22, \$7.30; No. 23, \$7.65; No. 24, \$8; No. 25, \$9; No. 26, \$9.50; No. 27, \$10; No. 28, \$11; No. 29, \$12; No. 30, \$13; No. 31, \$14; No. 32, \$15; No. 33, \$16; No. 34, \$17. Extras net. Tinned wire, Nos. 17-25, \$2; Nos. 26-31, \$4; Nos. 30-34, \$6. Coppered, 75c; oiling, 10c.

MISCELLANEOUS.

	Cents
Putty, 100 lb drums	\$2.70
Red dry lead, 560 lb. casks, per	
ewt.	6.25
Glue, French medal, per lb	0.10
Glue, 100 flake	0.11
White lead, ground in oil, No. 1	
pure, 100 lbs.	8.40
Tarred slaters' paper, per roll...	0.95
Motor gasoline, single bbls., gal..	24½
Benzine, per gal.	23½
Pure turpentine	64
Linseed oil, raw	58
Linseed oil, boiled	61
Plaster of Paris, per bbl.	2.10
Plumbers' Oakum, per 100 lbs...	4.50
Pure Manila rope	17

THE GENERAL MARKET CONDITIONS AND TENDENCIES.

(Continued from page 188.)

mills are booked up to the end of the year for bars. Toronto warehouse price for bars is 2.5 cents per lb, although they may, perhaps, be had for less. There are, of course, some mills in Canada not so busy as others; these are making prompt shipments. It was rumored in the market this week that a Canadian railway was negotiating for a supply of rails, and one firm in particular was making a bold bid for the order. The demand for steel wire keeps about the same. There is an unusual demand for baling wire for hay. Prices are the same, and business is good. The same applies to nuts, screws and bolts.

Metals.

The price of copper, the fall in which was noted last week, and which dealers did not believe could get any lower, has been falling nearly the whole week, much to the dismay of local dealers in metals and old material. The result has been stagnation in the market. This condition is applicable to practically all the metals. It is attributed to the uneasiness at present prevailing on the European Continent. The price of tin has fluctuated considerably during the week. Tinplate mills are fairly busy, and can fill orders in three months.

Coke and Coal.

Connellsville coke is a little easier, but this does not affect the market in Canada, as practically all the coke used is Solvay make, made in Detroit. In spite of a scarcity of railway cars, dealers are managing to keep Canadian furnaces and foundries well supplied. The end of the embargo on coal existing at the border on the G. T. R. resulted in a good supply of coal last week. This was followed up, however, by a similar condition on the C. P. R., so that coal is about as scarce as it was two weeks ago.

Montreal, Feb. 18.—The general machinery market during the past week has been excellent, all dealers reporting a good amount of business on hand. No special line seems to be exceptionally strong, the large machinery houses and the mill supply men being pleased with present conditions and optimistic as to the future. The large dealers are now awaiting the letting of contracts for the machinery and crane equipment of the N.T.R. car shops at Transeona. Rumor says that a decision on this matter will be quickly reached and that the shops will be rushed to completion and all equipment installed in from 6 to 8 weeks.

The Canadian Pacific Rly. have broken ground for their new steel car shops at Angus, and this will probably mean the expenditure of fully \$100,000 for equipment in the near future. An addition of 85 feet is also being added to the locomotive erecting shop. Altogether prospects are very bright, though the general tightness of money is resulting in a little difficulty in making collections.

Trade Gossip

The Smart-Turner Machine Co., Hamilton, Ont., have recently secured the following orders:—La Hine D'Or Huronia Dane Station, Ont., duplex pump; The Howard Smith Paper Mills, Ltd., Beauharnois, Que., three centrifugal pumps; Hamilton Bridge Works, Hamilton, Ont., duplex steam pump; Dominion Cannery, Ltd., Aylmer, Ont., duplex outside packed plunger pump; Dominion Steel Castings Co., Hamilton, duplex steam pump; H. Brennan & Sons Mfg. Co., Hamilton, duplex steam pump; M. O. L. Brewer, Fenwick, Ont., Rotary pump; The Western Dry Dock & Shipbuilding Co., duplex steam pump; The Great Lakes Dredging Co., Port Arthur, Ont., steam vacuum pump.

The John McDougall Caledonian Iron Works Co., Ltd., of Montreal, have been

awarded the contract for two 12 million Imperial gallon pumping units, at a price of \$50,046. The units consist of two 20-inch, three-stage Worthington turbine pumps, direct connected to 750 brake horse power Browett-Lindley high speed engines, running at 350 r.p.m. and operating against a water pressure of 92 pounds. The three-stage pump of the John McDougall Co. was selected as a type that already had given the city very satisfactory service for a number of years, operating 24 hours per day. This makes the thirteenth pumping unit furnished to the City of Montreal by the John McDougall Co. and Henry R. Worthington, aggregating a total pumping capacity of over 100 million Imperial gallons.

Catalogues

The Powers Regulator Co., 111 Fifth Avenue, New York, forward a copy of their bulletin dealing with the Powers system of automatic temperature control in connection with the heating of buildings. This system is too well-known to need more than mention, yet even those who are thoroughly familiar with it will doubtless value this catalogue, which is very clearly written and of most artistic appearance.

STAMPINGS Special Manufacturing to Order

No matter how hard a stamping problem you put up to us, the chances are we can satisfy you. Many people use stampings in place of castings and find them more satisfactory and often cheaper. Send blue prints and samples and let us quote you.

The Silent Partner is an interesting little magazine. We send it free—when there's a reason

THE GLOBE MACHINE & STAMPING CO.
899 Hamilton Street, Cleveland, O.

Points to be Observed in the Organization of the Factory

By John Calder

So much attention has been bestowed of late on the introduction of systems in manufacturing and industrial enterprises, that it is somewhat of a relief and refreshing to read and to know that without organization there is little hope for the successful outcome of any system, however studiously enforced. To successfully carry out a system, there must first be organization. The accompanying article should be carefully read by employer and employe alike.

IT is well for the young graduate, who sometimes thinks this is a very cold world for the fledgling, to realize fully from the first, that, while the engineer designs and constructs his apparatus to accomplish specific mechanical results, the basic motive throughout, is personal profit. Although the intellectual character of an engineering task is often of a higher order than some that might be named, and not seldom is greatly esteemed for itself, yet as a business proposition, it is on the same level as every other human service.

Problem to be Solved.

The business problem, therefore, in any undertaking is so to limit expenditure that a satisfactory margin of acquisition may be preserved. This requires the most effective teamwork on the part of the individuals who constitute the officers of the enterprise, as well as those who form the rank and file of the industrial army. Organization is the art of so uniting and directing these working forces as to produce the most satisfactory composite result. The function of the officers in engineering practice is not only to operate plants and various undertakings economically, but also to anticipate business fluctuations, to measure up with care the prospective value and desirability of extension, to check mere bigness of project and to make reasonable provision for a contracting expense of organization during periods of depression.

The Individual Feature.

Each individual must organize his efforts if he is to insure success. To attain economic distinction he must first have clearly in his mind what he desires to do, next he must wisely determine on the method he will adopt, and lastly, he must constantly and persistently prosecute it to the end. If he works on one plan for a time, then changes to another, only to change again and yet again, even to a better plan, he will prosper little.

What is true of the individual effort applies even more to the action and reaction of individuals in authority upon one another. With the substitution of the organization for the individual, new difficulties arise. The individual suffers only from his own lack of understanding, of judgment, of energy or decision, but,

when more than one person is concerned, there are the added dangers of misunderstanding, of clashing opinions, of diversity of interests, of insubordination and intrigue. Organization cannot wholly prevent these things, but it can greatly encourage or limit them according to its degree of fitness and efficiency.

Nature of Authority.

The question of the centralization of authority is one requiring careful consideration in connection with organization. There are two extremes. If the subordinate officials are wholly unrestricted in their actions, the interest of the industrial organization or of an engineering or transportation undertaking as a whole, is lost to view and harmony of action becomes impossible. If, on the other hand, all power of initiative is placed in the hands of a central authority, he is so flooded with detail as to cause great delay, and through inability to study varying conditions which arise, general rules are applied to special cases with such rigidity as to cause much loss.

Under such a scheme, the emergencies which arise in every undertaking are handled in a feeble, ineffective fashion and a disastrous breakdown of the organization is sure, sooner or later, to occur. The degree to which loss will be incurred is of course conditioned to some extent by the size of the organization, whether it be a railroad system, a large industrial establishment, a group of manufacturing plants or an enterprise of field work engineering.

Plans of Organization.

There are two main methods of handling the organization problem as a whole, namely, the divisional and departmental plans. Under the divisional plan, single plants and enterprises are given a more or less complete organization under a chief executive officer. The departmental plan, on the contrary, provides an officer in charge of all similar departments wherever situated, with sub-officers reporting to him at each place. In actual practice, the divisional plan of organization is never carried out in its completeness. Motives of economy and varying local conditions often do not permit of the theoretically necessary sharp separations of work at different places.

With the departmental plan of organization this difficulty disappears, but others are created. As a rule, no one department is sufficient unto itself, and some of its work requires the co-operation of other departments. In such a case, when lack of harmony prevails, reference has to be made much further up the line to a common superior than in the divisional organization, and consequently the chance of investigating into and removing the discord is more remote.

The divisional organization tends always to develop a more broadly trained man for the higher positions than the departmental. Such an official (particularly when a young man going through the lower grades of experience) is brought closely in touch with the working of departments other than his own, and usually makes the most of his opportunities. The recommendations and decisions of a divisional officer are therefore likely to have a wider point of view than those of a departmental official.

In actual practice, there is no sharp decision made between the two general plans outlined. It is usually a question of opinion and choice as to where the department plan shall end and the divisional begin. Sooner or later in the scale of operations, similar departments become so numerous and so large that they must have a common authority to refer to in the interests of harmony.

The Question of Leadership.

The detailed methods of operating an organization within departments and plants cover a wide field, and belong to the subject of System. It may be said here, however, that in a centralized organization the best safeguard against discord in the staff (whatever may be the organization plan) is the external vigilance of the chief officer in control, whose important functions we will proceed to consider.

Before outlining the principles of organization, the question of leadership calls for attention. The trend of much of our present publicity upon the subject of business management is one-sided. It lays too much stress on methods and too little on men. It exhibits too much faith in means and too little in manners. This is largely because so

many people without managing responsibilities are now professionally interested in magnifying the mere machinery of business. Both these factors require due consideration, but the human ones should have precedence.

Primary Object of Organization.

The primary object of organization is to bring brainy men together for work and action. A wise organization seeks and encourages men of ambition. It believes that the ambitious man is not necessarily dangerous. It knows that success demands an aggregation of strong individualities, free to contribute their quota of wisdom, but loyally subordinating their individual preferences to the general policy once declared, for, in order that its work may be well done, and its action strong and forcible, the organization must move forward as a harmonious unit. No amount of clever scheming with forms and regulations alone will ever secure this. Herein lies the task and the genius of the leader, the organizer of men as distinguished from the systematizer of things. Both are needed and it is always a happy circumstance when the qualities are combined in one man.

The work of the leader is much easier to talk about than to perform, but the most perfect system of handling routine fails to realize its possibilities when it is not co-ordinated and intelligently controlled by the official head of the organization.

Staff Relationships.

Having secured a competent leader for an enterprise and decided upon the general organization plan, we have to consider in the next place the principles on which he will handle the staff which he selects. Two questions at once present themselves for solution, namely:—What is to be the relation of each individual to those about him? and, what are to be the extent and limitations of their duties and authority? On the nature of the answers to these questions depends much of the future success or failure of the enterprise. Human nature must at all times be kept fully in mind just here, for the secret of success is to so arrange the units of authority that they shall act as one person.

Principles Worthy of Adoption.

1.—An executive with deciding powers is provided at all points where action must be taken. Failure to do this opens up the way for vacillation, jealousy, inefficient compromise and disorder. Responsibility divided invites evasion.

2.—The responsibility of each position is fully and carefully outlined. A simple chart is often useful in conveying such relations to others and helps to avoid the conflict and lack of co-operation which uncertainty creates.

3.—The duties of the various organization positions are made to conform satisfactorily to the ability of those chosen to fill them. This is a most important, and often, in re-organization work, a delicate matter with which no influence, or special interest, should be allowed to interfere. Sometimes the occupants must be changed to attain the end desired. At other times, it may be necessary to change the organization. Conformity to this condition must, however, be obtained one way or the other, and it is the virtue of a reasonable system that it never needs to throw away a good man. Expert engineers are sometimes wholly devoid of executive ability and yet may make excellent advisory members of the staff.

4.—No person is made subordinate to two or more others, if it can be avoided; this is a frequent source of trouble, ill-will and inefficiency.

5.—The power to discipline men in any department is allowed to rest in the hands of the official who is held respon-

sible for results. All appeals to the higher motives of subordinates are strengthened, not weakened, when they are made by the authority having the power of reward or of punishment.

6.—The duties of the members of the organization are distributed so that unequal loading is avoided. This is necessary in order to make fair comparisons of results. It also keeps the keen worker in the prime of condition and prevents the naturally indolent, though gifted man from deteriorating.

7.—Wherever possible, no positions on the staff are created which are cul de sacs for the ambitions, and permit of no promotion therefrom. This cannot always be obtained, but unless it is generally secured, even good men lose interest in their work and become inefficient.

The foregoing is from a paper read recently before the Efficiency Society, New York, the author being Factory Manager of the Cadillac Motor Car Co., Detroit, Michigan.

Regulations Concerning Apprenticeship

Apprenticeship forms an important feature in the industrial life of Great Britain, and in spite of the fact that such a system is practically unknown on this continent, we believe the accompanying article will be read with interest by and profit to employer and employe alike, setting forth as it does a very important side of welfare work.

MATHER & Platt, Ltd., Park and Salford Iron Works, Manchester, have issued the following regulations for the admission and control of apprentices. These are divided into three classes:—

Class I.

Boys, of not less than 15 years of age, are admitted as "Trade Apprentices" with the object of becoming "Tradesmen" on reaching 21 years of age. They must have passed Standard VI. at a primary school, and have attended a continuation school, or produce other proof of having a satisfactory elementary education, and must be capable, if required, of satisfactorily passing an elementary examination paper in arithmetic. They are required throughout the whole term of their apprenticeship to attend evening classes at the Manchester or Salford Schools of Technology, or other approved schools, and in certain cases, selected entirely by merit, are allowed to attend the special day courses for apprentice engineers at the Manchester School of Technology. This privilege is, however, only granted with the express permission of the works manager, and is restricted to those boys who can show that they will derive full benefit. No deduction is made from wages for

the time spent at these classes. Trade apprentices are paid wages from the commencement of their employment, according to the uniform scale in force and are advanced annually, if conduct and progress both in the works and in the classes have been satisfactory.

Class II.

A limited number of youths of not less than 17 years of age, able to submit a satisfactory introduction and references, and of giving proof of a thorough general education at a secondary school or public school, by examination certificates or otherwise, are admitted into the works from time to time as circumstances permit, with the object of obtaining practical training in different branches of engineering. Those who have had a recognized course of technical school, or have obtained distinction at a public school or grammar school, have preference in selection for this class. A knowledge of French, German or other modern languages, is considered an additional qualification. Youths in this class are transferred from department to department, so as to obtain as wide an experience as possible, but subject always to the shop conditions at the time permitting of entry into a

particular department, and to the express permission of the works manager. Mather and Platt consider that the best training is obtained by starting in the foundry, and then passing to the machine tools, fitting, and assembling. This course will be followed as circumstances permit. As far as possible, all youths in this class will spend some time in one or other of the test rooms, and in the drawing office. Those in this class enter the works for a probationary period of six months, during which time they do not receive any wages. From the end of this period, they will receive a weekly wage of \$2.50, and thereafter, up to the end of their apprenticeship, such wages as may be arranged by the management.

All youths in this class are required as a condition of their employment to continue their technical education, by attending evening classes at the Manchester or Salford Schools of Technology, or at the University; and in certain cases, selected entirely by merit, are allowed to attend the special day courses for apprentice engineers at the Manchester School of Technology, but this privilege is only granted with the express permission of the works manager, and is restricted to those youths who can show that they will derive full benefit. No deduction is made from wages for the time spent at these classes. Every youth admitted into Class II. must obtain a letter from his parents or guardians undertaking that they will not remove him during the time arranged for his apprenticeship without the consent of his employers.

Class III.

With a view to affording facilities for practical workshop training, a very limited number of young men of not less than 20 years of age, who have passed a complete course of technical training at a technical school, or who have obtained a degree or diploma in Engineering or Science at a University, are admitted into the works from time to time as circumstances permit. Anyone applying for admission into this class must have a satisfactory introduction and references, and must submit a complete statement of their educational career and attainments. It must be understood that selection is made, having regard to the educational qualifications that a candidate is able to submit, and that great importance is attached to a candidate having a thorough knowledge of French, German or other modern languages. All men in this class enter the works for a probationary period of six months, at the end of which time there is no obligation to remain, or on the part of the employers to continue the employment. If it is then agreed

to continue, the candidate must agree, in writing, to remain in the employment of Mather and Platt for the further period arranged. During the probationary period of six months no wages are paid, The remuneration during the further period will be subject to arrangement according to the merits of each case.

Although Mather and Platt cannot undertake any obligation that men in this class shall spend any specific time in any particular department, the management, as far as possible, will select the department or shops so as to give the best possible practical engineering training suited to the attainments and capabilities of each man, and not with a view to obtaining skill in any particular handicraft.

General.

Apprentices of all classes are subject to the usual works regulations and must keep shop hours, which are as follows:—

Monday to Friday inclusive, 8 a.m. to 12.30 p.m., 1.30 to 5.50 p.m. Saturday, 8 a.m. to 12 noon.

Mather and Platt in no case charge any entrance fee or premium, nor indenture any apprentice, nor undertake to continue the employment of any apprentice.

All applicants must be of sound constitution, and must, if required, produce a medical certificate showing their physical fitness for work.

Mather and Platt desire to draw attention to the age limit of 15, below which they will not in future admit any apprentice. This age has been fixed in order that boys may have the advantage of some instruction in elementary science at a continuation school before commencing work in the shops.

A member of the staff is deputed to keep a register of all apprentices, their educational record, the time spent in each department, the classes attended, and the reports of the masters. Apprentices are encouraged to consult with him from time to time as to any change in their employment which appears desirable, and he will endeavour accordingly to arrange it with the works manager. He will advise apprentices as to the classes that will be most useful for them to attend, and will pay the fees for the session for the classes selected and approved.

The Principals of the technical schools and of other schools whose classes are attended by Mather and Platt apprentices are invited to report at frequent intervals on their attendance and progress.

No holidays other than the usual works holidays are granted to any apprentice, except with the express permission of the works manager.

Mather and Platt wish it to be understood that they are able to accede to only a very small proportion of the applications made to them for entry into Classes II. and III., and that in making the selection of those to whom the privilege is extended, they are primarily guided by the intention of selecting those students whose antecedents, physical fitness, character and educational attainments, are likely to fit them for permanent posts on the staff. They also desire to point out that although the above regulations primarily apply to works employment, nevertheless it has always been the practice to select as far as possible those who have had practical training in the works for the more important posts in the office pertaining to the commercial side of the business, and it is their intention to continue such selection from the several classes of works apprentices.

IRON AND STEEL TRADE IN THE UNITED STATES.

IN discussing the development of the iron and steel trade in the United States during 1912, the Iron Age states that the most hopeful prophecies of a year ago were greatly inadequate, for the year witnessed the largest production of iron and steel in the history of the Continent in regard to both home consumption and the export trade. There is no parallel in American steel making, the journal states, for such a transition as that which occurred in 1912 from the common prediction that two or three years must pass before the gap between demand and capacity could be bridged, to a condition that called for plans or construction work to provide for an annual output of 2,000,000 to 2,500,000 tons a year more of open-hearth steel.

The increase in pig iron amounted to 6,000,000 tons—29,750,000 gross tons against 23,676,000 tons in 1911 and 26,095,000 tons in 1910. In Lake Superior iron ore shipments the indicated total is about 48,300,000 tons, an increase of more than 15,500,000 tons over that of 1911, which was 32,793,000 tons, and of 43,492,000 tons for 1910, the year of highest figures on record.

With regard to 1913, "it may be said that American steel manufacturers have never entered upon a year holding greater promise for volume of business, and those in the trade who made the largest predictions for 1912 are now committed to prophecies of still greater things for the new year."

Welland, Ont.—The capacity of the Ontario Iron and Steel Co., at Welland, Ont., is now 1,500 tons a month.

A BAROMETRIC CONDENSER.

AN original arrangement of a barometric condenser is in successful operation at the blast furnaces of the Canada Iron Corporation, Ltd., Midland, Ont. It was designed to utilize the returns from furnace water jackets for the purpose of condensing exhaust steam from turbine driven rotary blowers and auxiliaries in the power station, the location of the condenser permitting of this being done without the use of a circulating pump. After passing through the jackets, the cooling water flows into a trough at elevation 30.77 as seen on the accompanying illustration, and thence it flows by gravity to the condenser supply tank seen on the left. By this time the temperature has fallen to 70 or 80 deg. F., and the water is found to be a satisfactory condensing medium.

In starting up, the vacuum is obtained by means of water delivered through an 8-inch injector starting valve at the

delivered to the condenser, and at the same time avoiding the possibility of loss of vacuum due to eddies in this pipe. In case of the quantity of water coming from jackets being insufficient, an auxiliary supply may be obtained through a 12-inch pipe from the Company's elevated water tank.

This condensing apparatus was designed and built by The John McDougall Caledonian Iron Works Co., Ltd., in Montreal. It will handle 70,000 lbs. of steam per hour at a vacuum of 27-30 inches, and has been in continuous operation since June, 1912, giving very satisfactory service.



TO STOP THE LOSS FROM FIRE.

THE Ontario Fire Prevention Association has been formed. The objects are to promote the science of fire protection and fire prevention, and to spread abroad among the people some

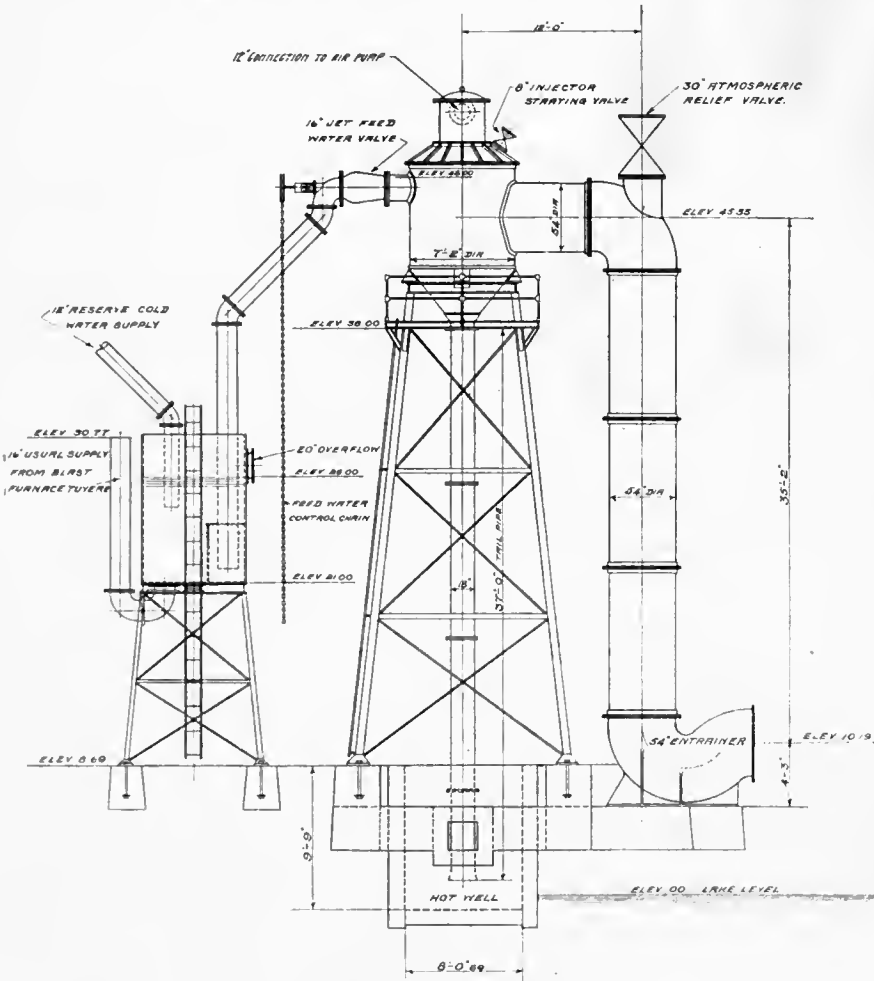

A BAROMETRIC CONDENSER.

top of the condenser, and after the vacuum is formed, the 16-inch jet valve is opened and water drawn from the supply tank into the condenser. This injection valve is of a special design to secure a very easy flow at the point of contraction, thus permitting of a very nice adjustment of the quantity of water

knowledge of the tremendous fire waste that is going on in Canada. When it is realized that during the last month the fire loss in Canada amounted to \$3,600,000 approximately 50 cents per capita, or more than the annual per capita loss in some European countries, surely it is time that Canada should wake up,

and do something to prevent this waste. This Association is born of necessity, and should receive the hearty co-operation and support of every citizen. The officers of the Association are:—President, Mr. W. H. Shapely, Eureka Refrigerator Co., Toronto; Secretary, Mr. W. Walker, Ontario Manager Hudson Bay Insurance Co., Toronto; treasurer, Mr. J. M. McIntosh, secretary Toronto branch Canadian Manufacturers' Association.

Executive Committee—Percy Robertson Fire Insurance engineer, Toronto; Dean Fernow, of the Forestry Department, University of Toronto; Chief Thompson, Toronto Fire Brigade; A. R. Clarke, A. R. Clarke & Co., Toronto; John Hunter, barrister; A. C. Lewis, secretary Toronto Harbor Commission; John E. Ellis, Barber & Ellis Co.; J. C. Scott, The J. C. Scott Co., Limited; E. P. Heaton, manager insurance Department, Canadian Manufacturers' Association; J. B. Laidlaw, chairman, Canadian section, National Fire Protection Association, U.S.A.; Paul Von Szeliska, insurance agent, Toronto, and a representative to be named by each of the following associations: Bankers' Association, Canadian Fire Underwriters' Association, Retail Merchants' Association, Canadian Society of Civil Engineers, Mutual Fire Underwriters' Association, Canadian Credit Men's Association, Toronto Board of Trade, Association of Fire Chiefs and Canadian Press Association.

The fire loss in Canada last year amounted to \$23,000,000, an annual per capita loss of \$3.07. At the rate at which we are going this year that may be doubled. One-half of this loss can be saved to the country, and it is with the object of bringing this fact home to the people of Canada that the Ontario Fire Prevention Association has been brought into being.



SUGAR REFINERY, ST. JOHN, N.B.

F. H. ANSON, managing director; Henry Holgate, consulting engineer, and L. I. Wilson, treasurer of the Atlantic Sugar Refineries, Ltd., along with Edwin J. Jarrett, vice-president of the Foundation Company, of New York, inspected the site of the new sugar refinery recently, and announced that work on the foundation would be begun and the work rushed night and day by the New York Company as soon as their plant could be got to the site. Owing to the nature of the ground, it will perhaps be necessary to go as deep as twenty-five or thirty feet in some places to get a solid foundation for the group of buildings to be erected at a cost of between \$2,000,000 and \$3,000,000.

Engineering Prospects in the Dominion of Canada

A correspondent of The London Times, in a recent issue, gives forceful expression to a series of views and opinions relative to the British manufacturer entering the Canadian industrial field, and while the data are perhaps more particularly applicable to the former, there is much in the contents of the accompanying extract that the Canadian producer and consumer may take note of and profit by.

ON a former occasion, some three years ago, attention was called to the value of the Canadian market for the products of British Engineering firms. At that time, reference was made to the disregard on the part of owners of British works of the enormous possibilities of the market in Canada, and criticisms were advanced against the opinion, which was at that time generally held, that British manufacturers could do nothing to cope with the competition of the United States.

Impression of U. S. Monopoly.

Even the Canadian purchaser was at a loss to understand why Britons should regard the Canadian market as non-existent, and the engineering trade of his country as an assured monopoly of American manufacturers. No one will deny the advantages of the position enjoyed by the latter; United States engineering standards were in vogue; the Canadian mechanic was familiar with the types of machinery manufactured by his southern neighbours; Canadian factories already had supplies of spare parts that would also fit any new machines that might be purchased in the United States; if new factories were established, it was American consulting engineers who were called in to advise as to lay-out and equipment; the standard size of various manufactured wares had been fixed by the American machinery by which such wares were turned out; and, perhaps most important of all, American engineering firms had established branch works in Canada for the manufacturing of machinery to American designs.

Change of Attitude.

On the other hand, no one who has watched events during the last three years can fail to realize the enormous strides that British engineering manufacturers have made in their attempts to secure a fair share in the Canadian market. Whereas a few years ago they were content to arrange agencies by correspondence and to obtain the infinitesimal amount of business that accrues from such agencies, the leading firms in this country have now sent out their own principals to report fully on the prospects and to arrange a plan of campaign, and have as a result in many cases opened their own offices in the leading cities of the Dominion, having realized that the most useful key to

the Canadian market, as to other markets, is the personal element.

Tenders and Deposits.

No small credit is due to the efforts of the Commercial Intelligence Department of the Board of Trade for bringing to the notice of manufacturers in Great Britain the opportunities awaiting commercial enterprise in Canada. The department has not only done that, but by the efforts of its Trade Commissioners from the east to the west of the Dominion it has been instrumental in removing many of the disabilities under which our manufacturers labored in the matter of submitting their tenders. It has secured timely information of the approach of calls for tenders; it has been successful in numerous cases in getting a reasonable time allowed for the preparation of tenders by these firms who had not yet seen their way to open their own Canadian office; and it has helped British manufacturers to obtain consideration in many cases where, without its assistance, their efforts would have been of little avail.

There is, however, one important point in which the department can render most valuable assistance—the question of deposits with tenders. There are many British works doing a large business on a comparatively small capital, and using all the means at their disposal to increase their output and to pay their materials and wages bills. Not only have these works, in starting business in Canada, laid out considerable amounts of immediately unproductive capital in traveling and hotel bills, but when their Canadian representative has gained an opportunity of quoting for a large contract, they have to find still further capital to provide a sum to cover the deposit required with their tender, which amounts in some cases to 10 per cent. of their total bid.

Such deposits are a restriction on business, and to the British engineer the demand may seem unreasonable. What is the reason for the demand? It appears to be to secure the due execution of the contract by the actual successful bidder, by preventing him, on pain of forfeiting his deposit, from farming out the whole of his contract to a third party at a lower price, and so securing to himself a fair profit merely as the result of having put in a tender without the intention of doing any further work

than that of finding his third party contractor. It is right that such trafficking in contracts should be prevented, but it is not the British way of making profits, although in the pioneering days of Canada there were many who made large sums in this way.

If the Canadian Government would prepare a list of acceptable British firms who may submit tenders without a deposit, the concession would be of enormous value. There can be little doubt that the system of "deposits with tenders" is a means of restricting competition to the oldest established firms, and of giving possibly a preference to the possessors of means rather than the possessors of ability.

Establishment of Works in Canada.

Canada in the course of a few years will be as much a manufacturing country as the United States, and she will be in a position to manufacture a far greater amount per individual employed than even Great Britain, since, there, over one million of the workers are employed in winning coal, which is a product that yields a comparatively small profit per man employed, whereas in Canada the fuel for factories is replaced in the majority of cases by water power. As compared with congested manufacturing districts in Great Britain, clustering round the coal pit mouths, there may be foreseen for her a vast expanse of townships, partly agricultural, partly manufacturing, with consequently far more comfortable conditions and a more healthy supply of labor, owing to cleaner surroundings and the intermingling of the agricultural with the manufacturing population.

Canada Alive to its Possibilities.

The Dominion is as conscious of the possibilities of the establishment of manufactures as the manufacturer is of the possibility of securing contracts. The State offers free land to intending settlers, while the townships offer free land and temporary exemption from local taxation to manufacturers to induce them to establish works within their boundaries, and compete almost as keenly for the favor of such as the manufacturers may compete for contracts from the municipalities. A glance at the list of articles of machinery admitted into Canada free of duty suggests that possibly the day may come

when machinery for the establishment of new works and industries may be admitted under much more favorable terms than at present. "Admission free of duty" is a concession already granted in such cases in many protected countries—e.g., Newfoundland and even Mexico, and it is not too much to hope that it is a system that may be adopted.

First Create a Market.

There is, however, one golden rule to be observed—namely, to create a market before establishing works, and, therefore, British manufacturers should do everything in their power to make use of existing and future opportunities of strengthening their hold on the Canadian market, and so establish a connection on which any works they may erect in Canada will be able to depend for immediate financial success. Otherwise, in future years, they may see the engineering requirements of Canada supplied by Canadian works in the hands of financial groups in the United States, or even of our own Continental competitors, and the channels open to the winning of profits, either directly or indirectly, in the Canadian market closed for ever to British capital and enterprise.



DEMURRAGE RATES UP AGAIN.

APRIL 15th in Ottawa may see a fight to a finish on the question revived by the following C.M.A. resolution:

"Resolved, that the Canadian Manufacturers' Association join in the application now before the Board of Railway Commissioners for a system of uniform penalties to be automatically applied against railways for their failure to receive, carry, and deliver freight within a reasonable time as required under section 284 of the Railway Act; such system to require the railways under penalty to place cars for loadings within forty-eight hours after ordered; to lift cars within twenty-four hours after notification of loading, and to place cars for delivery at destination within forty-eight hours after arrival; the penalties to be similar to those which the railways are authorized to charge shippers and consignees for delay in loading and unloading cars."

The Railway Commission has fixed the above date for the hearing of argument on reciprocal demurrage, and a vigorous debate is expected.

The temporary increase in demurrage charged by the railways expires automatically on April 1, unless the companies obtain a renewal. The old rate was \$1 for twenty-four hours after the free time; but the schedule permitted temporarily calls for \$2 after the first 24 hours following the free time, and \$3 for additional periods.

The Design and Operation of Special Chucks

By Charles Hattenberger

This article will be read with interest by shop draftsmen, tool room foremen and others who have to design special chucks from time to time. The writer makes no pretense at introducing any very unusual chucks, but has gathered together well illustrated example of the more commonly used types in the hope that they may suggest ideas to some readers of Canadian Machinery who have special conditions to meet.

WHILE the ordinary type of 3-jaw or 4-jaw chuck is indispensable in the machine shop and tool room, it does not meet all requirements for manufacturing purposes. This is especially true when there are large quantities of repetition work to be produced accurately and at a minimum cost. To do this efficiently very often requires the use of special chucks or fixtures for securely

5.—Is there sufficient clearance to allow drills, reamers, taps, etc., to pass through?

6.—Will the piece be firmly held, so that it cannot work loose or vibrate under heavy cuts?

7.—If the work is frail or thin, will the chuck crush it?

The accompanying illustrations show a few of the many different types of

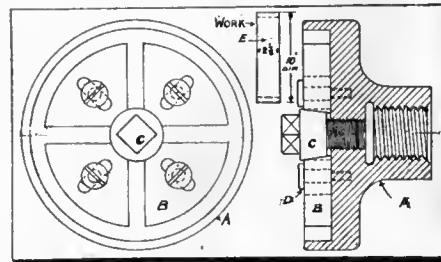

FIG. 2. AN EXPANDING CHUCK.

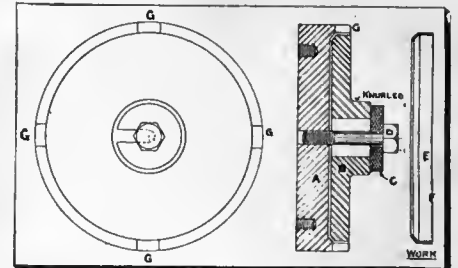

FIG. 3. A TRIMMING CHUCK.

and accurately holding the work during the various operations upon it; but before making a special chuck it is essential that the following questions be asked and satisfactorily answered.

1.—Are there enough pieces to be machined to make a special chuck pay?

2.—Would a set of special jaws attached to a standard chuck answer the purpose?

3.—Can the work be quickly inserted or removed from the chuck?

4.—Will there be an excess of overhang which may cause chattering?

chucks to be found. Doubtless some of them could be modified to suit some job the reader has on hand and wishes to handle to the best advantage.

A Grinder Chuck.

Fig. 1. shows a chuck used on a grinder for holding the pinion (G), while grinding the shaft of which this pinion forms an integral part. These pinions are of machinery steel, pack hardened. It was found that some were more or less sprung or twisted after hardening, and to remedy this it was thought advisable

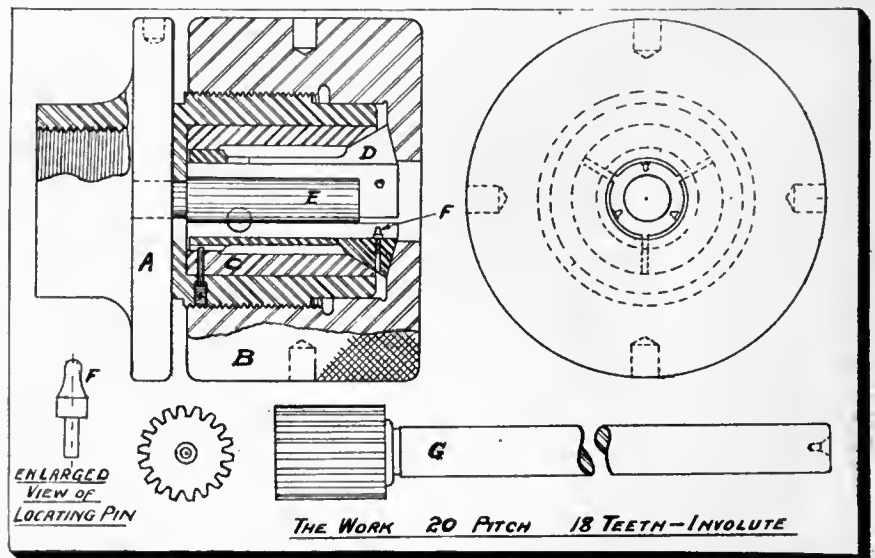

FIG. 1. A GRINDER CHUCK.

to make a special chuck and locate the piece by the teeth, a method which proved very satisfactory.

The body (A) of the chuck used is made of machinery steel. One end is threaded to fit the nose of the grinder spindle, and the other end is bored to receive the hardened and ground tool steel bushing (C), which is pressed in. In this bushing is fitted a hardened and ground tool steel split collet (D). The latter has three hardened tool steel lo-

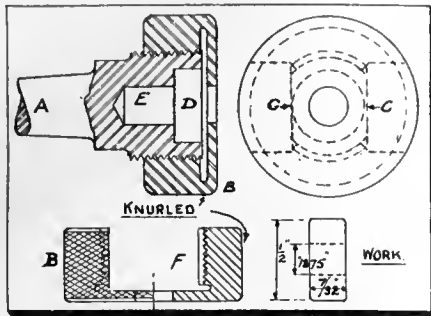

FIG. 4. A BREECH CHUCK.

eating pins (F), which were made in the following manner: The straight portion was first turned to size in a bench precision lathe. This straight portion was then inserted up to the shoulder in a collet in the lathe. A forming tool, made to conform to the shape of the pinion teeth, was then inserted in the lathe and brought forward by means of the crossfeed screw until the pin was of the correct shape and size. During this operation the carriage must be locked and the reading on the crossfeed dial should be noted so that the pins may be all of the same size. The three holes for these locating pins in the chuck collet are best drilled in the milling machine, using the dividing head for spacing them.

To operate the chuck insert the pinion (G) up against the stop pin (E) and screw up the knurled nut (B) until the pinion is securely held. The other end of the shaft is, of course, supported by the tailstock centre in the usual way.

The nut (B) is of machinery steel, pack-hardened. The straight and angular parts inside are ground. The collet

is prevented from turning by the small screw shown.

An Expanding Chuck.

The chuck shown in Fig. 2 was used for facing the cast iron bands (E) to the proper width. The body (A) is of cast iron, one end being threaded to fit the nose of the lathe spindle. The jaws (B) are of machinery steel, pack-hardened. They are secured by means of screws tapped into the chuck body and passing through slots in the jaws. The expansion belt (C) is also made of machinery steel, case-hardened, one end having a square milled on it for a wrench. The operation of this chuck will be readily understood from the illustration.

A Trimming Chuck.

The piece shown at (E) in Fig. 3 is a stamping. It was required to trim or face the edge (F). To do this quickly the chuck shown in the figure was used. The body (A) is cast iron and has a recess bored out to fit the work. Four slots (G) are cut in the rim to facilitate the removal of the work. The two tapped holes seen in the sectional view are for the purpose of securing the chuck to the lathe face plate by means of hex-

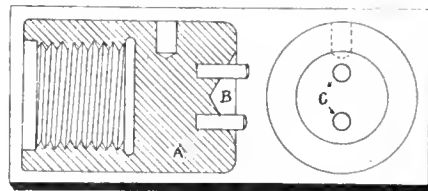

FIG. 5. A DRILL TURNING CHUCK.

agonal headed bolts. A tapped hole at the centre accommodates the clamping bolt (D), the head of which is preferably case-hardened.

The outer part (B) of the chuck is also of cast iron, turned to the inside contour of the stamping. The hole through its centre is bored large enough to pass freely over the head of the clamping bolt (D). A knurled and slotted machinery steel washer (C) completes the chuck.

To operate it the stamping is placed on the part (B) and both are passed

over the bolt (D) into the recess in (A) and there secured by the clamping bolt and washer.

A Breech Chuck.

A quick acting chuck used on a Rivett Internal Grinder is shown in Fig. 4. The work in this case was a hardened tool steel roller, 1/2 inch outside diameter, 7-32 in. wide and requiring a 3-16 inch ground hole in the centre. Many mechanics will doubt the feasibil-

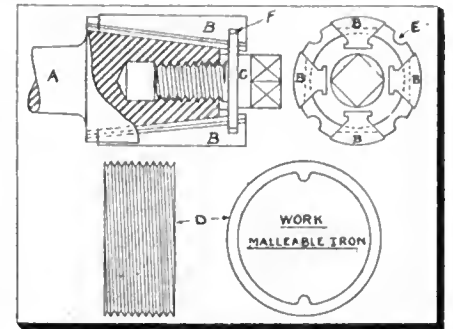

FIG. 8. AN EXPANDING CHUCK.

ity of grinding holes of so small a size, but the writer has seen a ring gauge having a hole only .022 inch diameter ground just as perfectly as one of 1 inch diameter.

The chuck for the job under present consideration consists of two parts. The machinery steel body (A) has a taper shank fitted to the grinder spindle and is screwed at its other end 9 threads per inch. Two flats are milled on the threaded end as indicated at (C), (C). A recess is bored at (D) of a depth which allows the work to enter freely to about three-quarters of its depth. A hole (E), slightly larger than the hole in the work, is drilled into the body to allow the emery wheel to pass clear through the work. The knurled nut (B) of machinery steel, has a hole of similar size at its centre. When this nut was finished in the lathe a sample of the work was inserted in the recess (D) and the nut (B) screwed up tight. Two slots were then marked off on the nut at right angles to the flats (C), (C). These slots are seen at (F) and were made slightly wider than the distance across

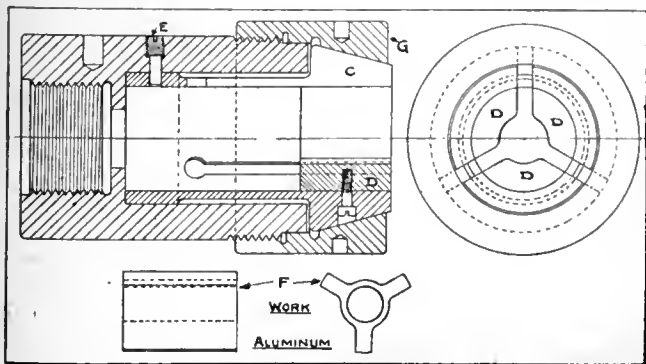

FIG. 6. CHUCK FOR ALUMINUM SPIDER.

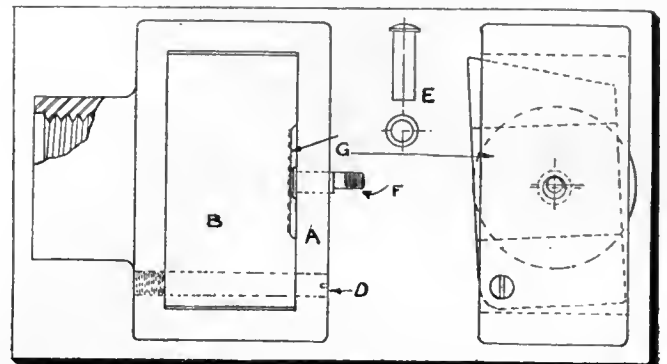

FIG. 7. AN ECCENTRIC CHUCK.

the flats (C) (C). They were easily worked out on a milling machine, using a small end mill for the purpose.

It will be seen that if the nut is turned back one-quarter turn it becomes entirely disengaged from the screw and the time expended in running it back off the thread in the usual way is saved. By this means the work is quickly inserted in the chuck and as quickly removed.

A Drill Turning Chuck.

Very often a twist drill shank has to be turned down for some special purpose. Anyone who has tried to chuck the cutting end of a twist drill knows the difficulties encountered. To do this class of work successfully the cast iron chuck shown in Fig. 5 was made. It is screwed to fit the lathe spindle nose at one end, while the other end has an angular recess (B), and two driving pins (C), the latter being made of cold rolled stock and driven into place.

When using this chuck, the twist drill point is placed in the recess (B) so that the pins (C) engage with the flutes. The shank end of the drill is of course carried by the tailstock centre.

Chuck for Aluminum Spider.

The spider-shaped aluminum piece (F) seen in Fig. 6 required to have a $\frac{5}{8}$ inch bored and reamed hole concentric with the outside profile of the casting. This was accomplished by the use of the chuck shown. As in the previous example the cast iron body (A) is fitted to the lathe spindle and is bored out to suit the hardened and ground tool steel collet (C). The auxiliary jaws (D) are also of tool steel, hardened and ground. They are made to fit the profile of the work and are held in place by filler screws.

The collet is prevented from turning by the screw (E). The closing nut (G) is of machinery steel, case-hardened, its inside straight and taper parts being ground. Holes are provided on the outside for a spanner wrench.

An Eccentric Chuck.

The chuck illustrated in Fig. 7 was used for cutting the eccentric stud shown inserted in the chuck at (F). It was only possible to do the first operation, as seen at (E), on the automatic screw machine. The succeeding operations of turning and threading the eccentric portion (F) were performed in a small turret lathe, using the chuck shown in the sketch. This chuck is also of machinery steel and is screwed to suit the nose of the spindle. A rectangular hole is cut in it to receive the hinged clamping wedge (B) which is also of machinery steel. At (D) is seen a pack-hardened and ground steel stud upon which the clamping wedge swings. The groove

(G) in the wedge is milled at a slight angle to give a wedging action against the rounded head of the work.

The hole intended to receive the body of the work is bored the correct distance off the centre of the chuck to give the threaded end of the work the desired eccentricity.

To operate the chuck the clamping wedge (B) is swung back, the work is inserted in the hole in (A) and the wedge (B) replaced. Since the hole in (A) is off centre the work cannot turn, no matter how great a strain it is subjected to. The wedge (B) only takes up the end thrust.

Another Expanding Chuck.

A malleable iron pipe nipple is shown at (D) in Fig. 8 and also the chuck used when turning and threading it. The chuck (A) has its shank fitted to the lathe spindle; while its larger end has four grooves (E) milled in it to clear the projections cast on the inside of the nipple (D). Four slots were also milled out on an angle for the hardened steel jaws (B), which are a sliding fit in the slots. Each jaw is nicked as shown at (F) to accommodate the flange of the case-hardened screw (C). It will be noticed that the screw has a coarse pitch to make it quick acting. As it moves in, the flange pushes forward the jaws (B), increasing the diameter over their faces and securely holding the nipple (D). The body of this chuck is of machinery steel.

WORLD'S IRON RESOURCES.

THE world's total actual resources of iron ore existing in deposits that can at present be worked at an economic profit have been estimated at 22,468,000,000 tons, representing 10,192,000,000 tons of iron. This total would supply the requirements of the world for considerably less than two centuries, even were the present rate of output not exceeded on the average.

The actual resources of the principal ore producing countries are estimated to be in the United States 4,258,000,000 tons, the equivalent in metallic iron being 2,305,000,000 tons; in Germany and Luxemburg, 3,878,000,000 tons estimated to yield 1,360,000,000 tons of metallic iron; in the United Kingdom, 1,300,000,000 tons, equal to 455,000,000 tons of metal; in France, 3,300,000,000 tons, equal to 1,140,000,000 tons, equal to 349,000,000 tons of metal.

In addition to these quantities, the potential resources of the world, not yet developed, are estimated to amount to 123,377,000,000 tons of ore, representing 53,136,000,000 tons of iron. Further, very large supplies of iron ore are un-

derstood to exist in China, Canada and other countries, but no definite information is at present available as to their extent.

The actual resources of the United Kingdom are calculated at 455,000,000 tons of iron, and the potential supplies at 10,800,000,000 tons, including 9,500,000,000 tons of metal contained in ironstone deposits in South Wales Scotland and elsewhere which are not yet workable.



ELECTRIC LOCOMOTIVES.

THE Electric Railway Journal points out that in the United States it is customary to employ a series of small and large circles or a succession of numerals to express the arrangement of the pony and driving wheels of electric locomotives. On the Continent the pictorial method is dispensed with, while the purely numerical arrangement, showing the number of each kind of wheel, is replaced by a combination in which a numeral represents the number of pony axles and an initial capital letter the number of driving axles. Thus, a locomotive with four driving axles only is designated as type D, instead of 0-4-0. Similarly, type 1-C-1 means one leading axle, three driving axles, and one trailer axle—a combination which Americans would designate as a type 2-6-2 machine. The plus (+) sign is used to show the division of driving axles on separate trucks. Consequently, a C + C locomotive is one with three driving axles in each of two trucks. This method of combining numerals and capital letters is as convenient to express or write as plain numbers, with the additional advantage that the typographical contrast between the numbers and letters emphasises the difference between the two types of axles almost as effectively as the circles.



INSULATING CONCRETE ROOFS.

INSULATING concrete roofs to prevent condensation beneath them is required in certain classes of structures, such as paper mills. According to an American engineer, a cheap and efficient method of insulating is to use a porous concrete made up of screened cinders and cement. A mixture of this kind which has given satisfactory results consists of one part of Portland cement and ten parts of clean steam boiler cinders. This should be placed as carefully as possible in order to ensure its porosity, and after setting, should be trowelled over with a flat coat of mortar to give a suitable surface for the roofing material.

Notes Concerning Methods of Drafting Room Lighting

By C. E. Clewell

The information contained in the accompanying article details the various arrangements and numbers of lamps adopted and installed in order to secure the greatest degree of comfort possible for the staff of a particular drafting room. As will be noted, this was secured without increasing the expense of lighting as originally existent.

FEW classes of work call for more active and constant use of the eye than that of the draftsman. The necessity for continual distinction of fine lines and details, and the use of finely divided measuring scales and delicate instruments, warrants a system of illumination free from everything likely to produce eye fatigue and eye strain, and capable of promoting ease and comfort in such work. The problem is not altogether one of providing light of high intensity. Far too much light may be as harmful as insufficient light. The general requirements for such lighting are:

- 1—Good and sufficient light for each person.
- 2—Uniform distribution of light provided by lamps in such number and so arranged as to furnish an illumination which is satisfactory without regard to the arrangement of drawing tables.
- 3—An arrangement of lamps that will avoid glare and subsequent eye strain.
- 4—A system which will furnish illumination on the drawing boards with a minimum of shadow effect when using instruments and ruling devices.
- 5—An intensity of illumination which will permit the discernment with ease of fine lines and details, and which will be sufficiently penetrating for tracing work.

Many Methods Adopted.

Numerous methods have been used for the lighting of drafting rooms, some of which possess several of the features outlined above, but seldom fulfilling all the requirements. For example, one method of drafting room illumination is that in which one or two light units, provided with reflectors, are placed close to the work. This system, shown in Fig. 1, casts an intense light on the

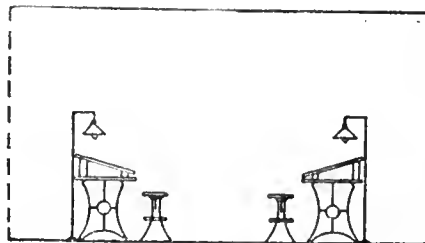

FIG. 1. COMMON FORM OF DRAFTING ROOM LIGHTING.

paper, which, however, is not uniform, it being necessary to change the units when the position of desks is shifted, often making wiring changes necessary in such cases. A system of this kind produces a glare from the surface of certain kinds of paper and subsequent eye fatigue. It should be further noted that the resulting shadows are excessive and this requires a continual shifting of the work or lamps, and a consequent delay and annoyance.

Test Data.

In an investigation of drafting room lighting, tests were made in a typical room with bays 16 by 20 feet and a ceiling height of 11 feet 6 inches. A sectional view and floor plan of such a bay is shown in Fig. 2. This typical drafting room contained an average of four tables per bay, and could accommodate four persons per bay. The room was originally equipped with large light units spaced on an average of from eight to ten feet apart and mounted ten feet above the floor or about five feet six inches above the drawing boards. The arrangement is equivalent to about three lamps per bay, or 25 watts per square foot. The complaints from the use of this lighting scheme were threefold:

1—The illumination was not uniform, the intensity on some desks being higher than on others.

2—The low mounting height of the lamps, together with the large size of the units required to furnish sufficient light, caused those in certain positions to suffer from excessive eye strain, both from the glare of the light source and from the reflected light on the papers.

3—Shadows from the small number of large units were dense, and required a constant shifting of the ruling devices so as to receive the light on the work at the proper place.

The Problem to be Solved.

The problem was to provide illumination possessing all the requirements as outlined above, and with features of such excellence as to be satisfactory in all respects for a class of work which rightfully calls for superior lighting facilities. The study of the requirements will show that uniformity, the absence of shadows and the reduction of glare are the conditions most difficult to obtain. Several methods were given thorough trial before the final scheme was chosen.

The first step was the installation of nine units somewhat smaller than those originally used, arranged as indicated in Fig. 3. Certain draftsmen were set to work in this trial bay. From the start the following items were observed: The intensity was excellent, the light uniform, and the glare not appreciable. It soon became apparent, however, that

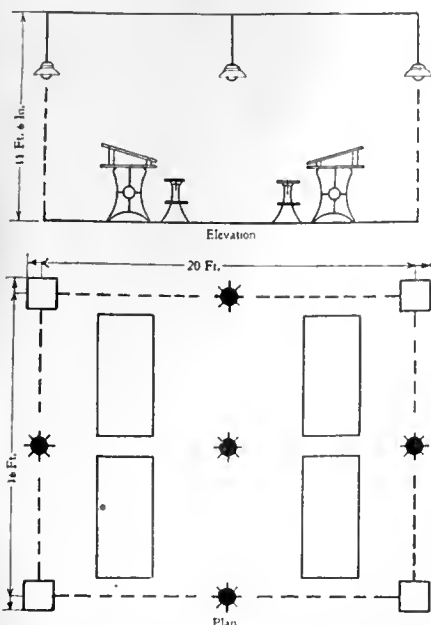

FIG. 2. TYPICAL BAY OF A DRAFTING ROOM LIT BY LARGE LAMPS.

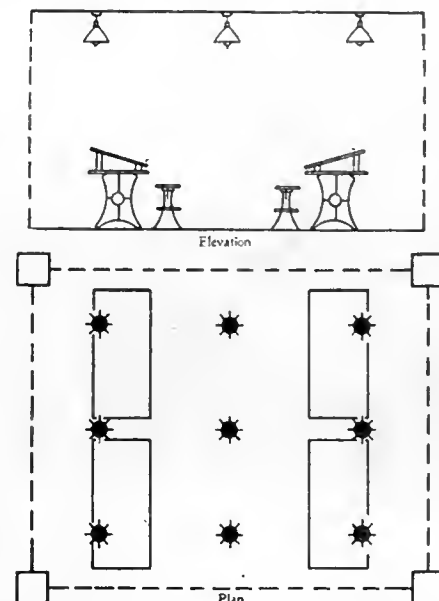

FIG. 3. TYPICAL BAY LIT BY 9 LAMPS.

the shadows cast by the large number of units were an objectionable feature. In drawing circles, and in the use of the divider generally, some nine shadows standing out in all directions from the instrument and apparently rotating when a circle was described were confusing and annoying. This feature naturally gave rise to considerable com-

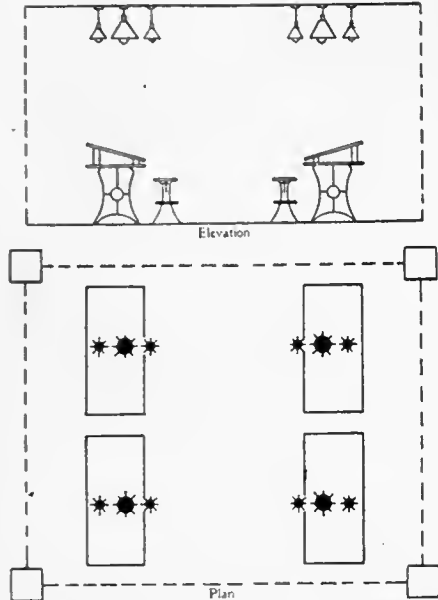

FIG. 4. TYPICAL BAY LIT BY 4-100 WATT AND 8-40 WATT LAMPS.

plaint, and led to the suggestion that the shadows might be diminished by the use of more units for a given floor space arranged in groups.

As a second experiment twelve units were arranged as shown in Fig. 4, the system being made up of four 100-watt and eight 40-watt tungsten lamps per bay. Draftsmen were then placed in this bay so as to work under the light for some days. The same trouble was experienced with shadows in excessive numbers, as was the case in the first trial, the effect being even more noticeable due to there being twelve lamps per bay instead of nine as before. The feature of uniformity was further inferior in this scheme, since the clusters may be considered as one light source so far as independence of desk locations is concerned, and the superiority of nine versus four light sources or groups per bay was demonstrated.

Other arrangements which were given trial were as follows:—One bay was furnished as an extreme case with 21 light units scattered over the ceiling. Here the shadow effect was perhaps somewhat offset by an excessive intensity, but the use of lamps in such numbers would be prohibitive in point of economy, and even if this were not the case it is questionable whether such large numbers of lamps would be admissible from the standpoint of good taste.

An arrangement of four 250-watt tungsten lamps per bay, equipped with broadly distributing reflectors, was tried. This arrangement, while possessing some good points, made use of units entirely too large for the ceiling height. Calculations were made to determine the minimizing of shadow effect in large rooms by the use of broadly distributing reflectors rather than those of a more concentrating type. This involves the building up of intensity at a given point by the light furnished by many distant light sources rather than being entirely dependent upon the light from one overhead unit. A man leaning over his work will cast a deep shadow, cutting off nearly all of the light if provided by one unit overhead and little or none from distant units; whereas if the units are provided with broadly distributing reflectors such shadows will be far less noticeable.

The plan finally adopted consisted of the use of sixteen 40-watt tungsten lamps per bay, arranged in clusters of four each, and by mounting the units on fixtures so constructed as to make use of the lamps in an inverted position, as shown in Fig. 5. The primary thought in this scheme was the attainment of a light free from the shadows found in previous trials. Various types of reflectors and fixtures of different shapes as well as effective mounting heights of the lamps above the floor were successively tried. With the ceiling freshly painted a yellow tint, so as to present a co-efficient of reflection of about 0.7, the following items were observed:—

Opaque reflectors, which furnished no transmitted light, all of the light coming from ceiling reflection, while

flectors of a softly diffusing quality of glass and which furnished a considerable amount of transmitted light to the work, seemed to fulfill all the requirements, as outlined above. Each draftsman, irrespective of desk or table location, received a good and sufficient light. This light was uniform and was made soft and free from glare by a glass re-

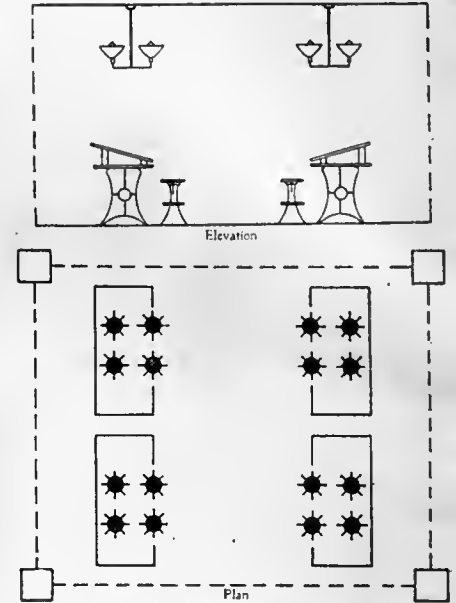

FIG. 5. ARRANGEMENT FINALLY ADOPTED, CONSISTING OF 16-40 WATT LAMPS.

flector providing excellent diffusion and a soft yellow tint. The shadows were eliminated, and with the use of the proper size of lamps an intensity of suitable value was provided throughout the room. This system has been in service long enough to show that, within the



FIG. 6. VIEW OF A DRAFTING ROOM LIT WITH INVERTED TUNGSTEN LAMPS FITTED WITH DIFFUSING REFLECTORS.

providing uniform shadowless illumination did not furnish a sufficient intensity for the work in question. The reflectors seemed to give the best results when mounted in a vertical position pointing upwards, rather than when mounted in an angular position. Re-

limitations of ceiling height and types of units and reflectors available, a very satisfactory result has been obtained.

Watts Per Bay.

It is of interest to note that the wattage per bay with this last scheme was

practically the same as that found in the original installation. Hence, the superior results were obtained by no extravagant installation of larger wattage, but by a carefully arranged plan of the equivalent wattage in another form. The approximate installation expense of the system originally found in use was slightly higher than the new one, and the operating expense was sensibly the same as that of the system finally chosen.

It should be stated that the final arrangement of this lighting system was the outcome of experiment rather than predetermination. Much careful study was given to the problem, as it had been anticipated that nine, or at least twelve units per bay, used so as to furnish direct light to the work, would be satisfactory. Draftsmen without exception, after working for a time under one trial installation after another, favored the final system as furnishing the best illumination of any that had been tried.

Different Intensity Requirements.

In such a lighting installation as that just described it is likely that different intensities of the artificial light may be needed at different portions of the day and evening. At first thought, the usual conclusion is that more artificial light is required at night than on cloudy days. Experience shows the reverse. During the day the eye is subjected to a stimulus from daylight intensities which are ordinarily many times greater than the intensities of artificial light commonly used. In the daytime this causes the pupil of the eye to be in a contracted state, so that it requires a greater intensity on the object than is necessary when the eye is relaxed as at night. Thus, on a cloudy day, when the daylight is insufficient, a greater intensity of the added artificial light is necessary to produce a satisfactory illumination on the working surface than at night. If the lighting system has been designed for an intensity suitable when used in conjunction with some daylight, it is quite possible that the intensity will be too high for comfort at night. Some way of changing the intensity of the light without destroying its uniform distribution is, therefore, desirable. If lamps be turned out here and there at random for the purpose of reducing the intensity to the proper value at night, the uniformity of the light is apt to be destroyed. One method of varying the intensity without destroying the uniformity of the light consists in installing the lamps in groups, and turning out a part of the lamps in each group. This affords different intensities without disturbing the uniformity of the light. Often, however, the lamps are not in groups,

The Tungsten Lamp.

The tungsten lamp possesses one feature which can be used to advantage in accomplishing this end, whatever the number and arrangement. From the normal voltage of the lamp to about fifteen or twenty per cent. below normal, the light of the tungsten lamp maintains its characteristic white color. The voltage on such a lighting system may be

reduced by means of a transformer arranged with a number of secondary taps to give voltages below normal, thus permitting a change from normal intensity to lower values without noticeably affecting the white quality of the light. This scheme has been used and furnishes a convenient method of varying the light intensity without destroying the uniformity of distribution.

Canadian Railroad Extensions and Betterments

This feature of the present issue contains brief accounts of the work planned by our three great railroads for the present year, and indicates conclusively the enterprise and progressive spirit which characterizes those responsible for their management.

G.T.P. CONSTRUCTION FOR 1913.

THE official programme of construction of the Grand Trunk Pacific for 1913 has just been made public. Whatever policy is adopted with regard to branch lines, it is generally understood that the first consideration of the company will be to complete the British Columbia section of its main line. The gap between the eastern and western heads of steel in British Columbia is now only 426 miles, and work on this portion of the line is actually under way throughout its entire length. Steel is laid into the Shuswap River, 1,123 miles west of Winnipeg, and 154 miles east of Fort George. A steel structure spanning this river will be placed in position as soon as footings have been completed.

East of Prince Rupert, the head of steel is now 195 miles from the Pacific Coast. Between that point and Aldermere several steel bridges have to be erected, and some grading must be done. From Aldermere, easterly, the grade continues to the Endaka River, 341 miles from Prince Rupert, there is then a gap of 126 miles to Fort George, upon which clearing work is being done.

Notwithstanding the heavy expenditure involved in the completion of the mountain section, the Grand Trunk Pacific will enter the towns of Brandon, Moose Jaw, Weyburn, Battleford, and Calgary this year, and will push forward with all possible speed important extensions already undertaken. This policy will mean the finishing of the Weyburn branch and Regina boundary line, securing of terminals in Moose Jaw for the Regina-Moose Jaw branch (which is complete to a point just north of Moose Jaw), the ballasting of the Battleford branch, and the construction into Calgary of the line from Tofield.

On the main line from Regina to the International Boundary, grading is finished as far as Frobisher, 136 miles from the capital of Saskatchewan, steel is laid for 106 miles to Hill Hall, and 90 per cent. grading is completed on the

remaining portion between Frobisher and the American territory. The grade on the Tofield-Calgary branch has virtually reached Calgary. Track is laid as far as mile 176, and ballasting operations will soon be commenced along this line until Bow River is reached, when a halt will be called to allow of the erection of a steel structure at that point. When that is completed, track laying will proceed to Elbow River, at which point another steel bridge will be put in place. Concrete piers are ready for the bridge in both cases. Terminals are now being prepared, and the line should be in condition for the operation of passenger trains into Calgary by August 1st next.

C. N. R. PROGRAM FOR 1913.

THE announcement of the C. N. R. construction program for 1913 was made on Tuesday, February 11.

Manitoba.

A stretch of one hundred miles, beginning five miles east of Portage la Prairie, and extending to near Stewburn, will be the main development. The Inwood-Fisher River route will be graded forty miles.

Saskatchewan.

A line from Sturgis for 44 miles towards Hudson Bay will be constructed. A like distance of line will be constructed on the Graven Branch. The line through Gravelbourg toward Swift Current will have more than fifty miles added to the present grade. The McRorie-Outlook line will be extended nearly twenty miles east of that point and about twenty miles west of it. The Regina, Moose Jaw line and the Yorkton branch are also included in the program.

Alberta.

The Camrose south-west branch will have sixty miles of new line constructed. About fifty miles will be undertaken on the Edmonton-Calgary line. The line

south of McLeod, at Pineher Creek, will be graded for about forty miles, and work on the Calgary-Lethbridge branch will also be undertaken. The linking up of the Brudheim and Vermillion connection and the tapping of the Brazean coal fields are to be rushed. The Peace River branch is also to have a start made on it. The Calgary-Saskatoon branch is now practically completed, and service will be established on this line within a few months.

NEW WAY OF GETTING A SPUR.

ONE of the important changes noticed in the revised Railway Act, which was introduced into the Ontario Legislature recently by Col. Hon. J. S. Hendrie, is that dealing with the power of the Ontario Railway Board to order switches to industrial establishments. The methods under the old section were roundabout, but the revised section simplifies the matter considerably.

If the change is adopted, the board will have power, where any industry lying within six miles of a railway wants shipping facilities and cannot agree with the railway as to construction and operation of a spur, to order the railway to construct and operate such a line. It may also direct the applicant to deposit in a chartered bank a sum sufficient to construct and complete the spur, and this amount can be paid by the board to the railway from time to time as the work proceeds. The aggregate amount so paid by the applicant in the construction and completion of the spur line shall be repaid or refunded to him by the company by way of rebate to be fixed by the board out of the tolls charged by the company upon the traffic over the branch.

Until he has been repaid, the applicant retains a special lien for the amount on the line, but upon receiving payment in full must give absolute ownership to the railway.

EXAMINATION OF UNDERSIDE OF RAIL HEADS.

AN interesting device to enable the undersides of the heads of rails and the upper parts of the webs to be conveniently inspected has been introduced on certain American lines. According to the Railway News, it consists of two mirrors inclined at such an angle that the reflection of the underside of the head of the rail can be seen readily by a person standing over the rail. The mirrors are held in a position by arms connected to a small wheeled frame running on the head of the rail, so that the appliance can be easily moved along. Pieces of spring steel are attached to this frame and fit loosely over the sides of the rail to hold the device in place. The

mirrors are either held rigidly in position by two arms or can be adjusted by set screws.

C.P.R. WILL SPEND \$16,000,000

THE Canadian Pacific Railway will spend \$16,000,000 on its eastern lines during the coming season. At least ten millions of the amount will be spent on work commenced last summer, including a portion of the new Lake Shore line, the extension from St. John's to Farnham Junction, and the Forsythe Street branch in Montreal. Double-tracking various parts of eastern lines will cost in the vicinity of six million dollars.

The main line from Islington to Guelph Junction on the London subdivision will be double-tracked for a distance of thirty miles, and it is expected the work will be finished by November. It is proposed to double-track between Romford, which is the junction between the main line and the Toronto-Sudbury branch, and Port Arthur, covering a distance of 135 miles. It is further intended, eventually to double-track the entire Toronto-Sudbury line, a total distance of 553 miles, in order to handle grain after the close of navigation on the lakes.

Another important work to be commenced this year is the double-tracking of a small stretch of fifteen miles between Agincourt and North Toronto.

RAILWAYS IN ALBERTA.

DURING the ten months which ended in October 31st last a total of 698 miles has been added to the length of the railways actually constructed in Alberta. The years which have passed since 1909 have shown an acceleration in the rate of railway building in Alberta without precedent in the history of the North American Continent. The most remarkable figures are those of the Canadian Northern Railway, which actually built during the first ten months of 1912 a mileage greater than the total of all previous years. At the end of 1911 the Canadian Northern Railway had 329 miles of line in the province. On October 31st the length of main and branch lines totalled 792 miles, an increase of 463 miles for the year. The Grand Trunk Pacific in the same period increased its mileage from 384 to 619 miles.

CUSTOMS REVENUE INCREASE.

DURING the ten months from the beginning of the fiscal year to the end of January the Customs revenue of Canada amounted to \$94,329,836; during the corresponding period in 1911-12 the Customs revenue was \$70,268,252, the increase being \$24,061,584. This works out as an increase of over 34 per cent. or over one-third.

Total Trade.

The total trade of Canada in January, 1913, was \$75,871,000, as against \$63,680,000, an increase of over \$12,000,000, or nearly 20 per cent. For the ten months ending January 31 last, the total trade was \$884,332,000, as against \$711,199,000 in the corresponding period in the last fiscal year, an increase of \$173,133,000, or nearly one-quarter.

Imports.

The imports in January 1913 were \$52,752,000, as against \$38,662,000 a year ago, an increase of \$14,090,000, or not far short of 40 per cent.; for the ten months' period the imports were \$549,445,000, an increase of \$128,000,000 over the \$421,114,000 of the ten months' period of 1911-12.

Exports.

The exports in January 1913 were \$19,370,000, as against \$19,527,000 in January 1912. In the ten months' period just concluded the domestic exports were \$298,022,000, as against \$246,442,000 in the same period a year ago.

CANADA BRICK CO.

THE St. Lambert plant of the Canada Brick Co. is now operating at full capacity. It has been turning out about 20,000 bricks a day since the first of the year. According to tests made at the laboratories of McGill University, these bricks are shown to have been of very high quality, and for tensile strength equal to the best pressed brick made. The Canada Brick Co. was organized a few months ago by Montreal financiers with a capitalization of \$1,000,000, made up of \$400,000 7 per cent. preferred and \$500,000 common stock. Half of each denomination has been issued. The Board of Directors consists of the following gentlemen: C. H. Cahan, K.C.; F. Loomis, H. A. Lovett, K.C.; G. F. Gyles and A. G. Cameron.

The plant at St. Lambert is one of two plants originally planned; the other plant, of a like capacity, is to be erected at Mile End, Montreal. Work on the latter will be started almost immediately.

CANADIAN CAR & FOUNDRY CO.

DURING the first four months of its new fiscal year ending January 31, the Canadian Car & Foundry Co. have shipped about 5,000 cars of a total approximate value of \$5,000,000. This is a gain of fully 25 per cent. over the first four months of the year before. Orders on the books of the company amount to over \$15,000,000, and are more than sufficient to keep the various plants going at capacity until September 30th when their year closes.

MACHINE SHOP METHODS ^A_N^D DEVICES

Unique Ways of Doing Things in the Machine Shop. Readers' Opinions Concerning Shop Practice. Data for Machinists. Contributions paid for.

AN IMPROVED TAP WRENCH.

By D. A. Hampson.

MOST vise hands at one time or another have been annoyed or perplexed by having to use a tap or reamer that was just a shade too large for any tap wrench at hand; yet an efficient substitute can be found in most well equipped shops.

Two Armstrong drill holders, clamped one above the other, make as good a wrench as could be desired and will stand all the tugging that two brawny arms can give them. The handles, being elliptical in section and a little

ed screw (C). The adjustment provided for is about 1-16 inch. By setting this feeler so that it will just enter the hole, one can easily detect the slightest variation, if the hole is not parallel. The device is made in different sizes, to suit holes from quarter inch diameter upwards.



PITCHING PROPELLERS.

By J. Livingston Booth.

OF all the problems confronting the marine engineer, there is none that presents so many difficulties as that of

will appeal to those engaged in this class of work, not only by its simplicity and inexpensiveness, but also on account of the rapidity and accuracy with which the pitch can be taken at different points on the blades of a propeller. It can be used for any type of propeller, and is especially useful for small ones having movable blades, and large ones having adjustable blades secured to the boss by bolts; when setting the required pitch, at the time the end pieces round the bolts, are being fitted.

The apparatus consists of a spindle (A), bolted to a suitable foundation, which may be of a permanent character, or if the apparatus is not in use sufficiently often to justify this, a marking out table can be used. The two cast iron blocks (B) (C) are a sliding fit on the spindle and are turned taper to take propeller bosses of different bores. Of the parts (D) and (E), which are also of cast iron, the lower can be fixed in any position on the spindle by means of the setscrew (F), while the upper half which is a running fit on spindle, has a lug cast on it to carry the steel arm (G). This arm is drilled at different distances from the centre of the spindle, usually increasing by 6 inches, to take the guide (H) and pointer (J), which has a movable collar and thumbscrew (K). The circumference of the part (D) is divided into 48 equal parts, while an arrow is stamped on the circumference of the upper part (E).

To take the pitch, the propeller is centred true with the spindle by means of the taper blocks (B) and (C), and the arm and pointer slipped on spindle, the lower half being secured by the setscrew at a convenient height to suit the length of pointer. The arrow on (E) is then set on one of the divisions on (D)

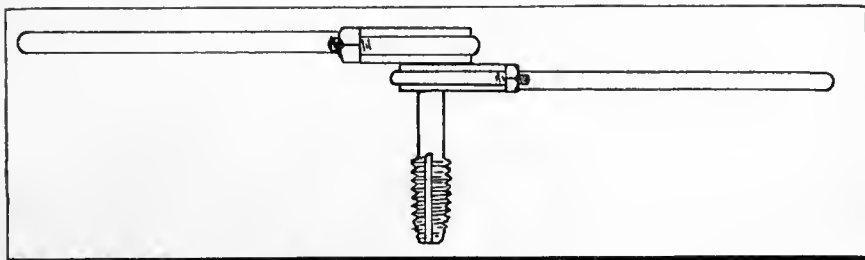

IMPROVED TAP WRENCH.

rough, give a better grip to greasy hands than the smaller finished round handles of the regulation wrench. The vee of the holder will not mar the polish of the nicest round tap shank.



A FEELER.

By A. L. Monrad.

THE accompanying sketch shows a device having a number of points that will commend it to tool makers, die makers and others when gauging a hole parallel to within .0001 inch. It can also be used for gauging a hole to a given diameter by first setting it to a micrometer reading.

The device is made rather rigid and is spring tempered. The legs (A) are pointed, so that the device only bears

propeller design. It is probably true that the majority of successful propellers are those in which the design has been based upon data obtained from the careful observation of the performance of propellers operating under as nearly as possible similar conditions. Therefore, whether we base our design on previous experience or decide to work on more scientific lines, it is necessary to have a means of knowing exactly the various conditions that we have to deal with, and also of insuring that the design is adhered to in manufacture.

A very useful piece of apparatus for measuring the pitch of propellers is shown in the accompanying sketch, and

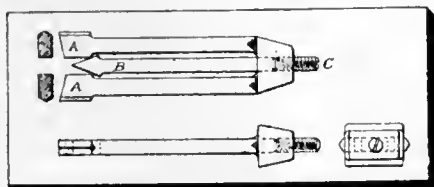

A FEELER.

along its centre line. The inside is cut away to accommodate the arrow-headed square (B) which forms a bearing for the legs (A) and spreads them to the desired size by means of the fine thread-

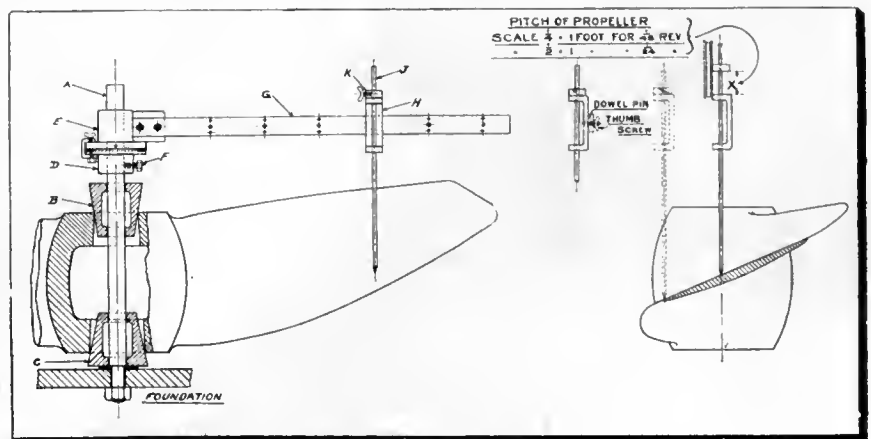

PITCHING PROPELLERS.

and the propeller swung round until the lower edge of one of the blades just touches the pointer when near its lowest position. The collar (K) is then tightened up to hold the pointer in a position just touching the blade. The pointer is then raised and the arm moved round 1-48th of a revolution. The pointer is then dropped until it just touches the blade, and the distance (X), read on a scale of 1/4 inch to the foot, is the pitch of the propeller. If it is more convenient to take two of the spaces for a reading, that is, a movement of 1-24th of a revolution, the distance (X) must be read on a scale of 1/2 inch to the foot. In this manner several readings can be taken across each blade at different radii from the centre.

In connection with this it is interesting to note the degree of accuracy that the British Admiralty consider necessary in the manufacture of propellers for torpedo boats and similar work. When the blades have been cleaned up and polished, the pitch is taken in the presence of an Admiralty inspector. A series of readings is taken close to the root of the blade, a second series near the tip, and either one or two series across the full part of the blade, depending on the size of propeller. The average of each of these series of readings at different radii is taken, and the average of the results obtained is again taken to give the average for the blade. This is repeated for each blade, and the average of the number of blades is then taken, which is considered the true pitch of the propeller. If this differs by more than a small amount from the designed pitch the propeller is rejected.

The writer has frequently used the apparatus here shown for Admiralty work of this description, and the large number of readings required can be taken in a very short time. There are many little improvements that will suggest themselves to the mind of the practical man, such as the guiding of the pointer to prevent its revolving and the addition of an arrow reading on a permanent scale attached to the guide. The apparatus can be modified to suit the conditions under which it is used.

SPEED PLATE FOR DRILL PRESSES

By D. A. Hampson.

OF WHAT use are the drill speed charts so plentifully distributed now-a-days if the operator has no means of knowing how fast his machine is running? True, he can probably figure out the speed, but in the time it would take him to do so, he could drill the hole at a somewhat lesser speed, which he knows to be safe.

To overcome this very real defect, the speed plate here shown is suggested. It

should be placed on the front of the machine in full view of the workman, and will tell him at a glance how fast the spindle runs with the belt on a given step of the cone pulley. Some of the more modern drill presses with all gear-speed changes are provided with such a plate; but the older machines, whose number is legion, have nothing of the kind.

Going a step further, the same scheme could be advantageously applied to millers and lathes. The plate could be made

SPINDLE RUNS				
CONE	1	2	3	4
R.P.M	53	114	224	460

SPEED PLATE FOR DRILL PRESSES.

to give surface speeds of a cutter or piece of work, 2 in., 3 in., 4 in., etc., in diameter. The machinist would then have a good average speed to go by, varying it slightly to suit the work in hand, and would not have to "guess" that he was right. Such a plate could be made to include the entire range of a machine's capacity, and could be as small as 2 1/2 x 4 inches without its being necessary to use glasses to read the figures.



JIG FOR FACING AND RADIUSING CONNECTING RODS.

By H. R.

THE connecting rods are of course understood to have been milled, bored, etc., the facing and radiusing being the last operation before finally bolting together. Into the cast iron base

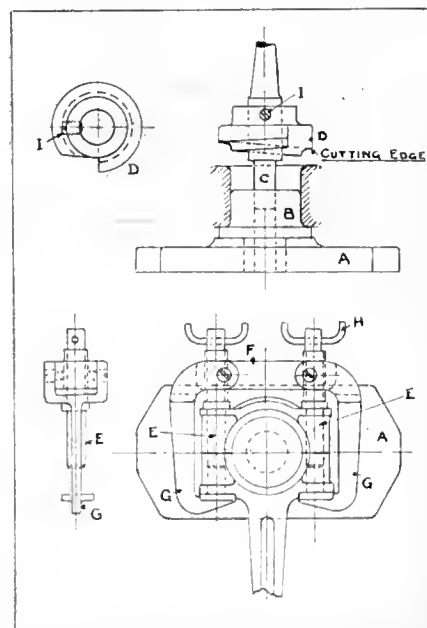

JIG FOR FACING AND RADIUSING CONNECTING RODS.

(A), is fitted a plug (B) of machinery steel hardened and ground to suit the bore of the connecting rod. Through this plug, a pilot hole is drilled and ground to take the pilot (C) of the facing tool (D). The connecting rod cap and connecting rod are now threaded on to the hardened steel plugs (E); these screw through the cross member (F). The arms (G) are mild steel forgings, which are hinged on to the cross member (F) and swung into position on to the shoulders of the connecting rod. By turning the thumb screw pieces (H), the plugs (E), operating with the arms (G) and cross member (F), grip the connecting rod and cap, making thus one solid piece. They are now ready for the facing and radiusing to be done, and same will be found a light operation, amounting to simply holding the small end of the rod and gradually bringing down the cutter on to its work.

It will be noticed that the cutter (D) has a spiral of 10 degrees cut to the form required, so that same can be ground on the cutting edge and always keep its true form to the last of the tool. The cutter is adjusted by the screw (1) on the pilot (C) as it gets worn. The apparatus can be used either in the drill press or in the lathe. The connecting rods are faced down to a snap gauge.



PROTECTION OF ALTERNATORS.

THE protection of alternators whilst running in parallel and while synchronizing is an important detail and deserves some consideration. In colliery work continuity of supply of power is the most important matter to be considered, and it is, therefore, essential that in case of bad synchronizing both generators shall not be disconnected from the circuit. This is guarded against by fitting reverse current relays on each generator. These reverse current relays protect either machine from being motored. The relays are set to operate on a small percentage of the full-load current of each machine. They are made on the same principle as an ordinary wattmeter, viz., in case of a reversal of current the instrument also reverses and closes a local circuit, in which the machine circuit breaker is included. It is also essential that time-limit relays should be fixed for each generator. The time limit should depend upon the load. Should an incoming machine be running too fast when switched in, and it snatches all the load, a time limit gives the machines a chance to right themselves before they are cut out.

DEVELOPMENTS IN MACHINERY

A Record of New and Improved Machinery Tending Towards Higher Quality and Economical Production in the Machine Shop, Blacksmith Shop or Planing Mill.

HEAVY DUTY 18-INCH "MUELLER" ENGINE LATHE.

THE 28-inch heavy duty lathe here shown is a recent development of the Mueller Machine Company, Cincinnati, Ohio, who state that "Heavy Duty" is no misnomer, practical tests having proved the lathe's capacity for rapid production. Accuracy of alignment and durability are points that have been given special attention. The lathe swings 18 $\frac{1}{4}$ inches over the ways or 13 $\frac{1}{4}$ inches over the carriage and will turn 2 ft. 4 $\frac{1}{2}$ inches between the centres. Drive is by a 3 $\frac{1}{2}$ inch double belt running on a 3-step cone pulley, the smallest diameter of which is 9 $\frac{1}{4}$ in-

itself, every gear having a bearing on each side. The carriage has very long bearings on the Vee's and has an adjustable taper gib the full length of its bearing against the rear side of the bed to provide against the possibility of its twisting under heavy cuts.

The bed of this lathe is 6 ft. 3 $\frac{1}{4}$ inches long, and the net weight of the machine, 3,200 lbs.

MOTOR-DRIVEN COMBINATION PUNCH AND SHEAR.

THE accompanying illustration shows remarkably well the space and power-saving advantage of a motor

could be utilized for any other purpose—and this machine is installed where space is valuable—in the Saginaw shops of the Pere Marquette Railroad. The motor is geared directly to the main shaft of the machine with simple reduction gears; there are no belts or pulleys. This means minimum transmission losses as well as the simplest construction and fewest number of parts. The machine has a 42 inch throat opening at each end, and both the punch and the shear are operated by the one motor. The punching capacity is a 1 $\frac{1}{4}$ -inch hole through 1 $\frac{1}{4}$ inches of mild steel. The shear end can cut a 2 $\frac{1}{2}$ inch round bar, a 2 $\frac{1}{4}$ inch square bar, a 1 $\frac{3}{4}$ inch x 6 $\frac{1}{2}$ inch flat mild steel or a 4 x 4 x $\frac{5}{8}$ inch angle. A bevel shearing attachment for beveling boiler plates is part of the equipment.

The frames of the machine are of the uncored I-beam type. The cam shafts are both open hearth steel forgings, and the clutches, which are provided with both hand and foot control, have an adjustable automatic stop attachment which can be set to stop the rams at any desired part of the stroke. Adjustable counterbalance weights connected through springs minimize the shocks of operation. The total weight of the machine is 45,000 lbs. The motor is a Westinghouse 10 h.p. machine-tool motor, operating on 220 volts alternating current.

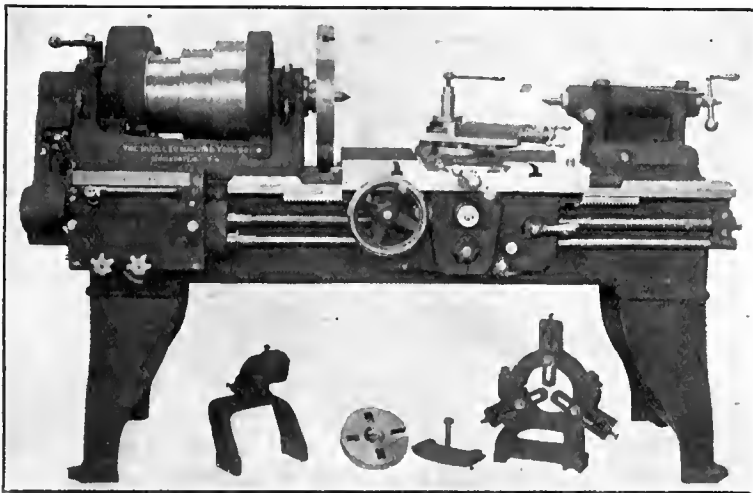

MUELLER HEAVY DUTY 18 IN. ENGINE LATHE.

ches, so that ample belt contact is provided.

The spindle is of high carbon crucible steel, ground to size, and runs in phosphor bronze bearings oiled through sight feed oilers and felt pads. Nine spindle speeds are provided ranging in geometrical progression from 13 to 300 R.P.M. The quick change gear box enables 45 changes of thread to be cut. These range from 2 to 60 threads per inch and include 11 $\frac{1}{2}$ threads screwing. The ends of the shafts in gear box are arranged to receive change gears when it is desired to cut metric or special threads. A chasing dial on the carriage enables the operator to catch threads instantly without having to return the carriage by reversing the countershaft or stopping the lathe.

The double plate apron is a rectangular box in which all bearings for the gears are cast integral with the bearing

drive over other forms. The motor is tucked away in a corner in the frame of this Wickes Bros. combination punch and shear, taking up no space which

A NEW LUFKIN RULE.

EVERYONE having use for a rule graduated down to 64ths of an inch knows the difficulty of obtaining accurate measurements in laying out work,

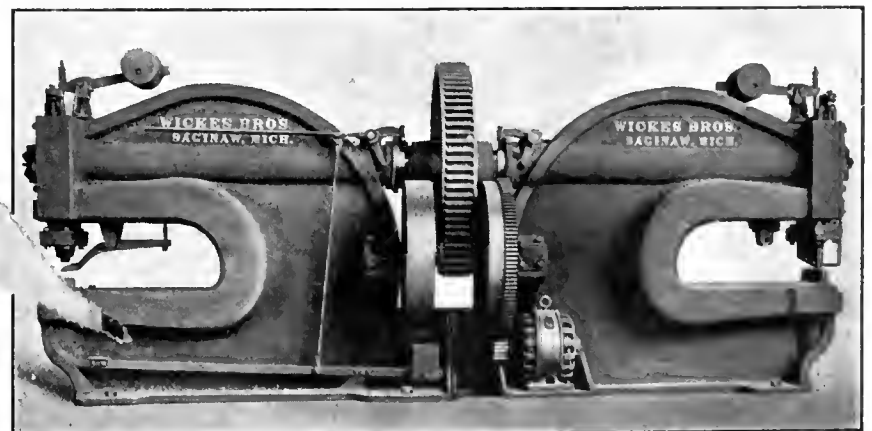

MOTOR DRIVEN COMBINATION PUNCH AND SHEAR.

knows how impossible it is to get the reading instantly, knows of the eye-strain attendant upon reading such graduations repeatedly; all caused by the fineness and closeness of the lines, one to another, necessary to get 64 lines in an inch. Under the eye, the lines have a tendency to "run together." Also, because the lines are so close together, it is impossible to number each one, and, therefore, after arriving at the measurement, it is necessary to refer back to the last figure and count up the 64ths. It is evident that if the same measurement could be arrived at with the same degree of accuracy with a rule graduated down not finer than say 16 lines to the inch, these difficulties would be overcome.

Both of these things are accomplished in the "Allen" Improved Scale - an article just put on the market by the Lufkin Rule Company. The "Allen" scale is a patented article, and embodies an absolutely new idea in the marking of a machinist's scale. As any even number of 64ths has an equivalent in 32nds, and possibly in 16ths, one side of this rule is graduated in 32nds and 16ths, and it takes care of all of the even 64ths. The other side of the rule embodies the new idea. It takes care of all of the odd fifths. The first graduation mark on one edge of this side is 1-64 inch from the end of the rule, and is number (1); the

and 5-64 inch points would come one odd 64th, i.e., the 3-64 inch mark; between (5) and (9), the 7-64 inch mark, etc. All of these odd 64ths appear on the other edge of this side of the rule; that is the first graduation mark there is, 3-64 inch from end of rule, and is numbered (3), the next is 7-64 inch, and numbered (7), etc., in each inch.

Thus the object is accomplished; all of the odd 64ths are here given, and yet there are only 16 lines to the inch. This makes it possible to number each graduation mark, and by making each second graduation mark, slightly longer than the one before and after it, the figures can be put on in two rows, allowing room to make them large enough to be easily read.

The rule is $\frac{3}{4}$ -inch wide, and is furnished in the two thicknesses commonly known as the tempered and the semi-flexible. It is made in various lengths, and the greatest demand no doubt will be for the 6-inch length.

The Lufkin Rule Company of Canada, Ltd., manufacture rules and measuring tapes of every description at their factory, which is located at Windsor, Ont.



NO. 2 DUPLEX MILLING MACHINE.

FOR manufacturing, which requires the milling of two opposite sides true and parallel, the duplex type of

ed upon to be uniform; then as the two cuts are taken at once, twice as much work is turned out, and the time taken in setting up for the second cut is saved on every piece as well.

In the machine shown, which is intended for light to medium work, the heads have independent micrometer adjustment to and from each other, and the spindles have independent vertical adjustment, with micrometer hand wheels. The cutters can thus be adjusted to the work in every way, and corners and ledges can be finished as well as simple flat surfaces. The spindles are taper and run in solid bronze boxes of the standard form of the makers. The drive is by linked train of gears from the driving shaft, which runs along the rear side of the bed. Changes of speed are provided by the cone pulley on the driving shaft, which is back-geared 3 to 1. The feed is driven from the driving shaft to the left hand end of the bed by a series of change gears, which are all covered and handled from below, giving twelve changes, ranging from 1-200-inch to $\frac{1}{8}$ -inch per turn of spindle. The table is deep and $9\frac{1}{2}$ inches wide, with ample (T) slots. It is fitted with automatic trip and reverse, right at hand, and quick movement by screw handle of 1 inch per turn. The feed screw is driven direct by a hardened steel worm gear and tool steel worm running in oil bath. Oil pan and reservoir take care of the lubricant, and extensions are provided to catch drip of table. All gearing is adequately protected. The above duplex milling machine is made in four sizes and five capacities, the makers being The Garvin Machine Co., New York.



TESTING A MICROMETER.

SOME purchasers of micrometers never really consider that it is necessary to test these tools. While we feel quite certain regarding the accuracy of the tools sent out, still we believe it is an excellent plan for users to have some means of properly testing them and doing so periodically.

After constant use, a micrometer shows some wear, and unless this wear is overcome by adjustment, one naturally is not going to get the correct measurements when using the instruments. Where it has been customary to test the micrometer, it will be found in the case of a 1 inch micrometer that it is often done by running the screw down until the point engages with the arvil and noting if it is correct, then by running it out to the 1 inch limit, testing it with a 1 inch guage. Some users, however, want to be more particular and they test the micrometer at $\frac{1}{4}$ inch

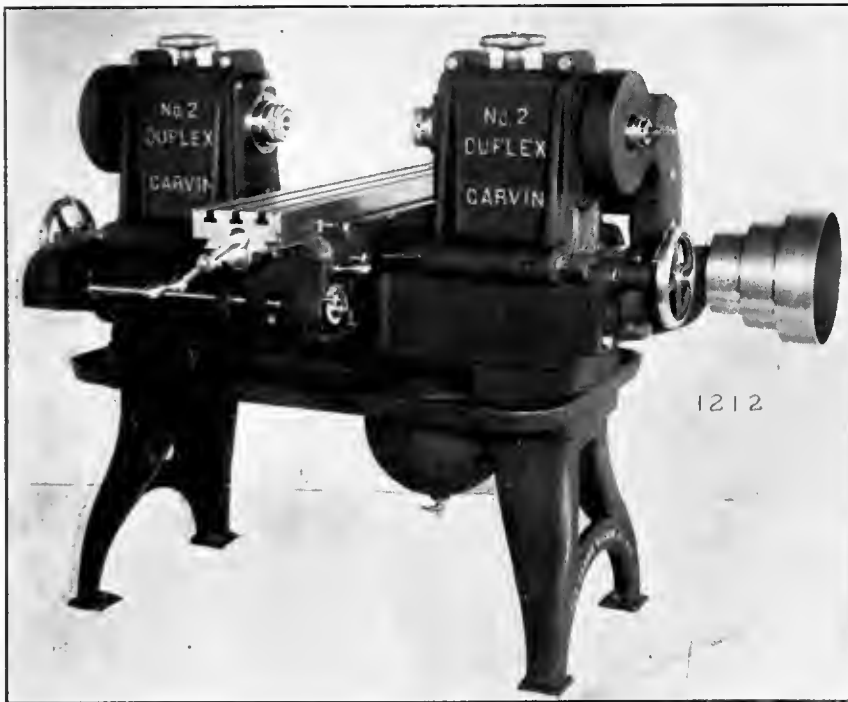

GARVAN NO. 2 DUPLEX MILLING MACHINE.

next mark on that edge is 5-64 inch from end of rule, and is numbered (5); the next (9); the next (13), etc., up to the first inch mark, and repeated for each inch. Here, there is a jump each time of 4-64ths, and between the 1-64 inch

machine has been evolved absolutely the best, both for accuracy and speed. In the first place, the trueness of the work depends upon the machine instead of on the care and skill of the man in resetting, and can, therefore, be depend-

(.250"), $\frac{1}{2}$ inch (.500"), $\frac{3}{4}$ inch (.750") and 1 inch (1.000"). This of course gives them a more accurate testing of the travel of the screws. This is good so far as it goes, but it leaves untested one feature of the micrometer that is particularly important. It is important that the travel of the screw be accurate



DRILL GEARED TAPPER.

and it is also important that the face of the anvil and the face of the screw be parallel and also perpendicular to the axis of the thread. It will be noted by testing the screw at the four points mentioned above that the thimble and the screw would be relatively in the same position as associated with the anvil in each case, but simply that the opening between the anvil and the screw would be greater. In order to properly make a test, a micrometer should be turned one half way around and tested at that point which would give the result mentioned as being omitted on the first test, that is, by turning the screw one half way around, it tests the travel of the screw and shows that the face of the anvil and screw are parallel as well as perpendicular to the axis of the thread.

The J. T. Slocomb Co., Providence, R.I., are putting on the market a set of reference discs No 80 containing one each $\frac{1}{4}$ in., $\frac{1}{2}$ in., 9-16 in., $\frac{3}{4}$ in. and 1 in. disc by means of which a 1 inch micrometer may be accurately and properly tested. Such a set as this, we believe, will be particularly attractive for manufacturers to place in their tool and inspection departments where the micrometer may be periodically examined and tested for accuracy.

14 INCH DRILL GEARED TAPPER.

THE accompanying illustration shows a 14 inch Drill Gear Tapper arranged to operate the clutch by foot motion. The foot treadle, when released, permits the clutch to drop in forward position, and, when pressed down, causes the clutch to operate reversely. When desired to keep the clutch in the neutral position, the small dog attached to the vertical rod is pressed in towards the frame, where it catches a lug on the latter and holds the clutch neutral. The arrangement permits the operator to use both hands.

The Rockford Drilling Machine Co., Rockford, Ill., are the manufacturers.



14 AND 16 INCH MOTOR DRIVEN LATHE.

THE Conover-Overkamp Machine & Tool Co., Dayton, Ohio, has just brought out a new 14 and 16-inch motor driven lathe. The illustration shows these machines with a new design headstock arranged for motor.

This new headstock is well ribbed to take care of different strains while under cut, and is cast in two pieces. The lower half forms the headstock proper, and the upper half forms a base for the motor and completely covers all running parts, doing away with numerous loose gear guard pieces. The back gears are placed in front instead of on the back of headstock, making them accessible to the operator without reaching or going around the lathe to throw them in or out. Due to this feature, these lathes may be placed close to a wall, saving floor space.

The drive is obtained by motor shaft

pinion through intermediate gear to friction gear on spindle. By means of this friction gear on spindle, the lathe may be started or stopped while the motor is running, allowing the latter to retain its normal speed. This friction is operated by the horizontal lever on the headstock. The headstock is equipped with either single back gears, or double friction back gears, these are operated by a vertical lever on front of headstock.

With a 3 to 1 variable speed, D.C. motor, a wide range of spindle speeds, approximately 13 to 400 r.p.m. may be obtained, allowing ample opportunity for all classes of work. The motor is controlled through a drum type controller, and is operated by lever placed on apron. The position of this lever being to the right of operator and working in a vertical position, places it in the most convenient and natural position for the operator to handle. All working levers on this lathe being in front, the operator has at all times full and quick control of lathe, saving many unnecessary steps.

The dimensions of these lathes are the same as the Standard 14 and 16-inch machines built by this company, and the motor driven type lathe can be furnished with quick change gear, as shown on illustration, or with an all geared feed or standard belt feed.

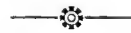

Montreal, Que.—It looks as if work would be commenced in the spring toward putting an artificial ice plant in the Arena. Additional buildings will be erected partly for the plant and partly for a general enlargement of the seating capacity, which is to be increased by at least fifteen hundred. It is understood that the Arena people count upon a five years' contract with the Wanderer and Canadian hockey clubs.

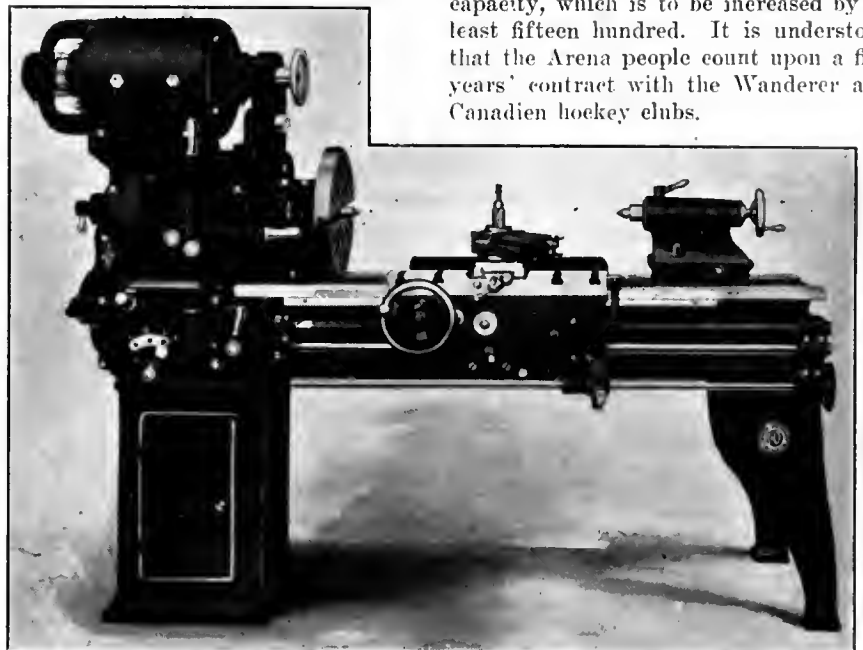

CONOVER-OVERCAMP 14 IN. AND 16. IN. MOTOR DRIVEN LATHE.

FOUNDRY PRACTICE AND EQUIPMENT

Practical Articles for Canadian Foundrymen and Pattern Makers, and News of Foundrymen's and Allied Associations. Contributions Invited.

NOTES ON A BEDDED-IN JOB.

By Joseph Horner.

THE group Fig. 1 shows a standard column of girder section made and used, with slight modifications in detail, for foundry and machine shop purposes. The columns were cast in two lengths and bolted together by the flanges at (A). The illustration shows the casting for the upper length. The end opposite to (A) carries the roof principals. As is usual in cast iron, the neutral axis of the casting is lightened by the holes shown, which are encircled by ribbing. Sundry brackets and

a very slight quantity of taper is required in that direction; but as the sand above the web has to be lifted from the inner edges of the flanges, a

The strength might be preserved if the holes were cored, but that would entail some unnecessary work. The holes are, therefore, cut out, and the ribbings put on in pieces as shown by Figs. 3 and 4. The semi-circular ends, Fig. 4, are turned in segments, four to the circle, in order to avoid short grain, and are glued and screwed on, completing with the straight portions the ribbings. Ample taper is given, about $\frac{1}{8}$ inch on the outside edges, and about the same on the total depth inside. The large flange has planing strips on its outer and inner faces which must be left loosely skewered, as in Figs. 2, 3 and 5. Being planed,

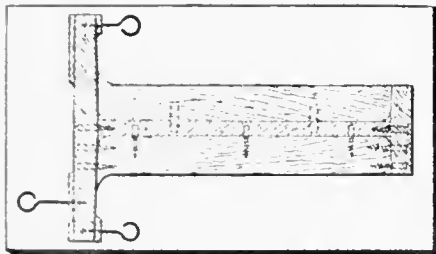

FIG. 2. A BEDDED-IN JOB.

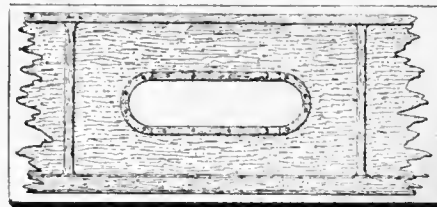

FIG. 4. A BEDDED-IN JOB.

considerable amount is given there, as seen in the sections, say $\frac{1}{8}$ inch. A like amount is applied to the bottom, not because it is necessary, but for symmetry. The cross ribs in the top are left loose, Figs. 2 and 5, being dowelled on as shown, while the corresponding ribs in the bottom are screwed fast both to the web and flanges, helping largely to stiffen and maintain the truth of both. If these ribs were not present, temporary ones would have to be inserted, otherwise the timber would curve and bend

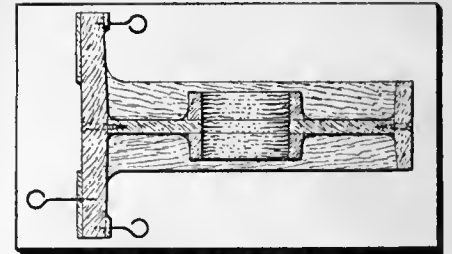

FIG. 3. A BEDDED-IN JOB.

facings are attached, which form the details that are altered for different sets of castings. The job is a comparatively plain one, but it affords a useful object lesson in some of the work of bedding-in with a rather deep top lift.

Pattern Features.

Such a pattern should never be jointed along the plane of the centre of the web, but, instead be made solidly as seen in the sectional views, Figs. 2, 3 and 5. The parting joint of the mold thus comes along the top edges of the flanges. The pattern is then withdrawn right from the top to the bottom edge. Only

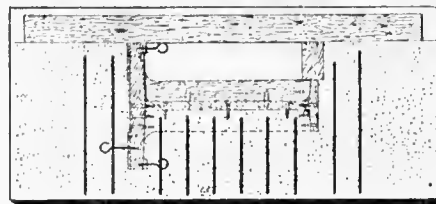

FIG. 5. A BEDDED-IN JOB.

across its width during ramming, and afterwards when in the stores. The stuff is moreover slightly weakened by the lightening holes in the neutral axis.

these afford means for the accurate attachment of brackets and bearings at any future time. Other fittings seen in Fig. 1 require no observations as they are permanently attached.

Molding Features.

Such a pattern is molded with the deepest fittings downwards. In this case the deepest portion is a bracket which carries the runway or gantry that sustains the rails for the overhead traveler. This is seen in Fig. 1, and in the section taken at x-x. As the pattern is bedded in the floor, and as it is not

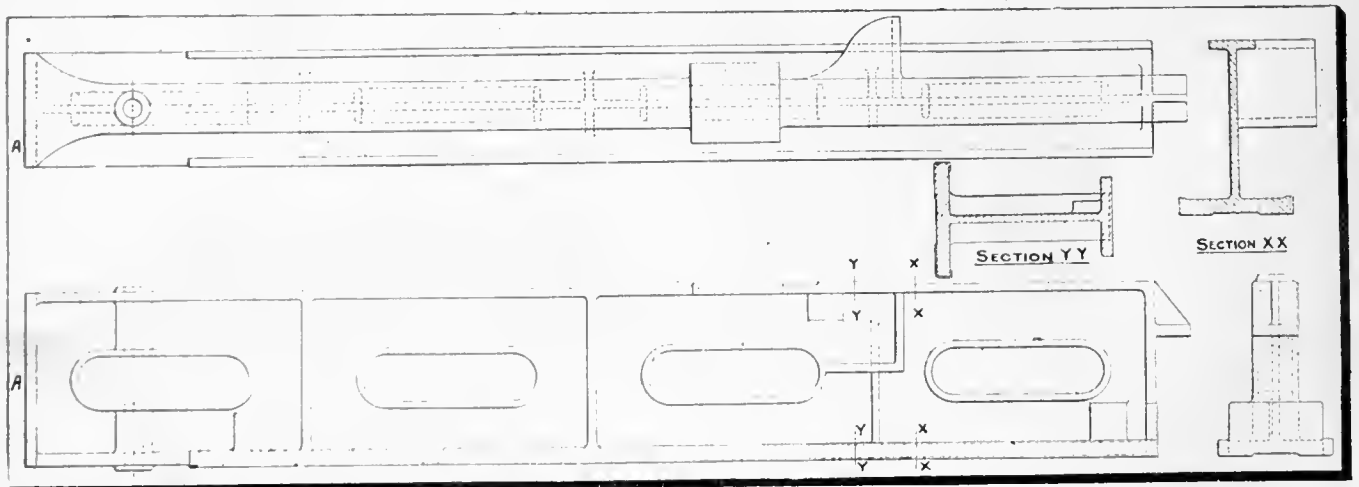

FIG. 1. A BEDDED-IN JOB.

sufficiently rigid in its longitudinal direction to resist twisting and bending, the bedding-in is rather a tedious affair, and caution has to be exercised in this part of the work.

First, a rough trench is dug with shovels, into which the pattern is laid, and very lightly beaten down on the loose sand with wooden mallets. It is then lifted out, and sand is removed from the hardest portions of the bed, and additional sand laid over the areas where contact has not occurred. Then a stratum of facing sand is shovelled or sieved all over, and the pattern is beaten down again. The winding strips should now be first tried across the flanges; blocks of wood being placed on the edge of the shallower flange to bring the winding strips up horizontal, Fig. 5. At the higher corners, the flanges are beaten down until the strips are level; also a long straight edge is tried longitudinally on the flanges to ascertain if they are curved lengthwise. If so, the higher parts are also beaten down.

The pattern is now removed, leaving ample indication of its bedding in the mold. The whole of this, except the outer faces of the flanges which are not rammed yet, has now to be gone over carefully in detail in order to effect the complete and final consolidation of the lower mold which lies between and under the flanges. The molder's hands play

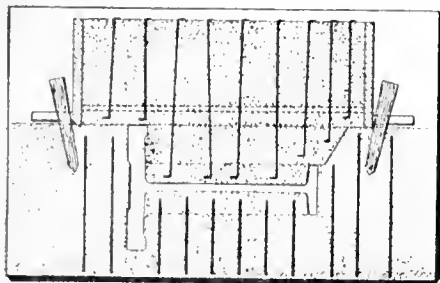

FIG. 6. A BEDDED-IN JOB.

an essential part in this portion of the work. By the pressure of the hands on the sand, its degree of looseness or closeness is ascertained easily. The hands also do much in consolidating the loose sand by simple pressure on it. In corners and in very loose portions the rammer is used, and so on until all the area is made of about equal consistence. A loose cross rib or two is useful to lay in its mold sections during this work. The pattern is put back once more, bedded down by the mallet and then removed, leaving a little finishing to be done, and the venting. The vents are carried downwards perpendicularly all over the face of the web, which will meet diagonal vents made later. The pattern is now replaced and the ramming-up of the outsides of the flanges is done to their top edges, and the joint faces sieked level with those edges. The

numerous diagonal vents are next carried down from the joint face all the length of the pattern to meet the vertical vents.

A plain top is afterwards lowered over the mould and set by means of four stakes, located by lugs, or by strips on the sides near the ends. As the lift between the flanges is a deep one, numerous lifters or (S) hooks are hung

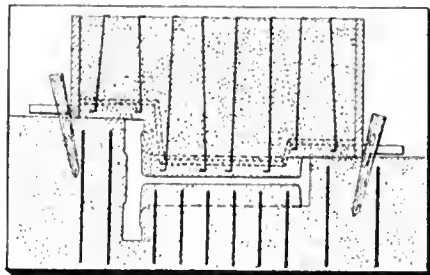

FIG. 7. A BEDDED-IN JOB.

from the bars or stays. With these and the bars well swabbed with claywash, the sand is rammed, completing the top. Numerous vents are then carried down perpendicularly to the web.

The top may be molded in either of two kinds of top flasks, one of the regular plain tops used for any miscellaneous work, or one made specially for the column. The latter would be adopted when a large number of columns were required, as when a large new foundry or machine shop is in course of erection. Both methods are shown. A plain top is illustrated in section in Fig. 6. Here it is necessary to bring the joint face from the shallow flange up level with that of the deep flange. This is done by making a long sloping sand joint as shown. As a large mass of sand then hangs below the bottom edges of the box, lifters must be hung thickly from the top edges of the bars, reaching down nearly to the web of the pattern. When a top part is made to suit the pattern, the sectional shape will be as in Fig. 7, the bars being cut to follow the

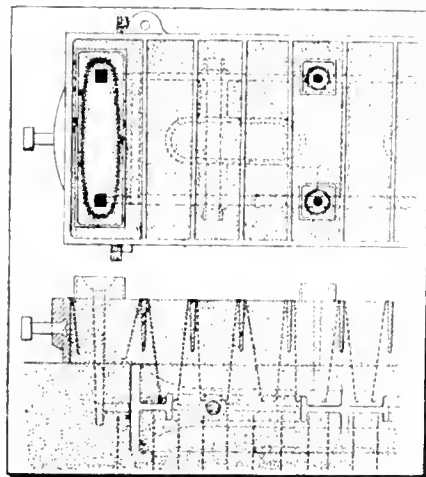

FIG. 8. A BEDDED-IN JOB.

outlines, and at a distance of $\frac{1}{2}$ inch or $\frac{3}{4}$ inch away. Lifters will still be required, but they will not be so numerous as in the previous case.

When the top is lifted off, bringing with it the ribs left loose therein, the edges of the sand next the internal ribs and web will be found more or less fractured. These must now be gone over and made good by using a strip laid against the edges, nailing weak sections where much fresh sand has to be added, and stiffening with claywash, and sieking with a wooden rubber and a trowel.

Fig. 8 illustrates the method of pouring, which is done in like manner from both ends. From a large basin the metal is let in by two runners and ingates entering the webbed portion of the mold. A few risers placed at intervals along the top edges of the flanges relieve the strain on the mold and receive dirt.

MACHINE FOR RECOVERING METAL FROM FUMES.

AN invention recently perfected by Sir Oliver Lodge and his son, Mr. Lionel Lodge, is expected to confer considerable economic benefits upon the metal industry, while also operating strongly in the direction of improved public health in manufacturing areas. In all metal works, fumes are driven off which are extremely deleterious to public health, and how potent is their influence is best realised by a survey on vegetation. What is not generally realized, however, is that while the manufacturer has been bound to allow the fumes to escape to the detriment of his neighbours, he is himself losing considerably in the process. The fumes are heavily laden with metals and acids of considerable commercial value.

Sir Oliver Lodge has been working since 1884 on the machine which he and his son have now invented, and it is claimed that over 90 per cent. of the metal which now escapes can be saved by its use. In some instances the inventors have succeeded in "retrieving" 98 per cent.. The machine is electrical, cheap in installation, and economical in operation. The commercial value of the results is said to be substantial. In the case of large copper works, the saving is estimated in thousands of dollars a year. Exhaustive practical tests of its utility are being made.

SPECIFICATIONS FOR AUTOMOBILE BRONZES.

THE following specifications for bronzes were accepted at the recent meeting in New York of the Society of Automobile Engineers:

Hard bronze, 87 to 88 per cent. copper, 9.5 to 10.5 tin, 1.5 to 2.5 zinc. Gear

bronze, 88 to 89 per cent. copper, 11 to 12 per cent. tin, 0.15 to 0.30 per cent. phosphorus. The hard bronze, it is explained, is identical with the United States Government bronze (G), having a tensile strength of approximately 35,000 lb. per square inch. It is offered as a general utility bronze for severe working conditions where heavy pressure and high speeds obtain, for light gears, valves, etc. The gear bronze, it is added, is commonly known as English gear bronze and is serviceable for gears and worms where the requirements are severe, especially when quiet running is a desired feature. Some makers, it appears, temper this alloy with a ferrous hardener, using quantities up to 4 per cent.

NEW SAFETY DEVICE FOR ROLLS.

IN rubber factories and other industrial works where rolls are used for crushing and grinding, it is often necessary to feed the material into the rolls by hand. The operation is carried out with more or less danger to the workman, and he often suffers the loss of fingers, if not a hand, before the rolls can be stopped. A safety device for use in connection with such work has recently been placed on the market by the Dodge Manufacturing Co., Mish-

awaka, Ind., and thence down to (G) where it is secured. In an emergency, the operator pulls the cord and this releases the heavy weight (D) which is held in position by the hook levers (E) and tripping links F. This weight (D) is carried on the lever (H), and when (D) is released, this lever moves rapidly downwards and strikes a lug (not shown) on the clutch-operating shaft, which promptly disengages the clutch. The large handwheel shown is employed in throwing the clutch into gear, it is disconnected from the mechanism by the shifting of lever (A) which slides the pinion (B) out of mesh with the toothed segment (C).

The device originally worked out for the Mishawaka Woolen Co., has operated with such success that it has also been adopted by the Rubber Regenerating Co. of the same city.—I.T.R.

TIGHTENING HAND-HOLE COVERS UNDER STEAM PRESSURE.

A FATAL scalding case due to the blowing off of one of the caps of an economizer at a mill at Liverpool, recorded in Board of Trade Report No. 2,162, illustrates the danger that attends the tightening up of external hand-hole covers under steam pressure. The

was of good average quality, and given fair treatment was sufficient for the purpose intended, but it is desirable to point out for the benefit of all boiler attendants that the nut of a 5/8-inch bolt can be easily twisted off with a spanner 9 in. long, and that any attempt to tighten up the caps of economizers while at work is a direct contravention of the makers' specific instructions that under no circumstances should any of the joints be interfered with whilst under pressure. This is by no means the first accident of the kind that has occurred and we trust the publicity given to the occurrence may be the means of preventing their repetition in the future.

PROCESS FOR BABBITT-LINED BRONZE BEARINGS.

THE Doehler Die Casting Company, Brooklyn, N.Y., have recently brought out a new process of making a babbitt-lined bronze bearing. A mixture is used which is plastic while hot, but hard when cold. In this manner the bronze part is made by taking the heated mixture and forcing it by means of hydraulic pressure into a steel mould. A hard, accurate shape is thus produced ready for lining.

The lining of the shell with babbitt is the novel part of the process. A rolled,

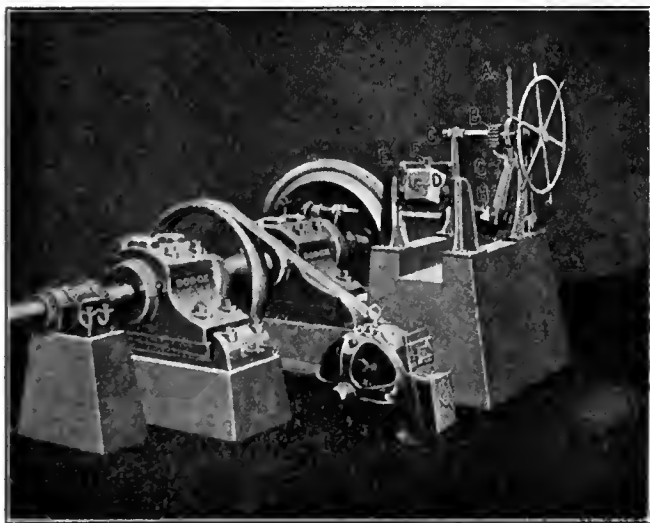

Fig. 1. Safety Device For Use With Hand Fed Rolls.

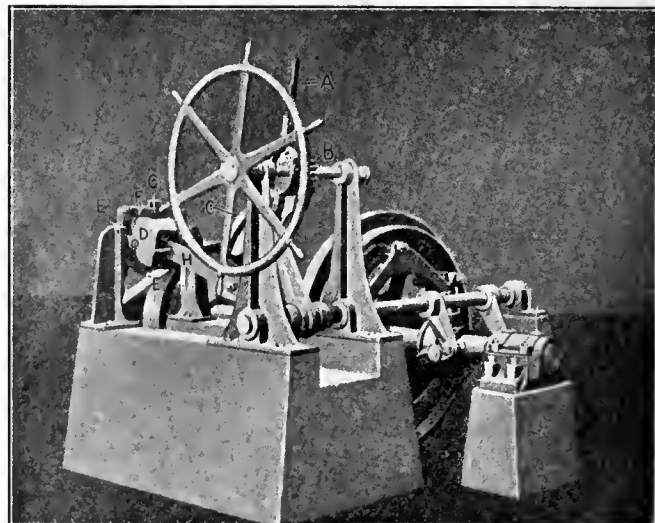

Fig. 2.—Safety Device Detail.

awaka, Ind., the construction and operation of which is shown in the accompanying illustrations.

Fig. 1 shows a line shaft for supplying power to rolls. This shaft running in extra heavy and rigid Dodge self-lubricating pillow blocks of the rolling-mill type, and carrying an iron centre wood-rim pulley and a 60 inch split friction clutch, is driven by the motor shown.

Referring to Fig. 2, a stout cord is carried from a point convenient to the roll operator by means of overhead pulleys to a pulley vertically above the

cap, which was of external oval shape and fitted over an opening of 2 3/4 in. diameter, was secured by means of two bolts, 3/8-inch diameter, and the joint between the cover and flange was made with packing material about 1-16 inch thick. It appears that as the cap was leaking slightly, the engine attendant proceeded to tighten it up with a 9-inch spanner, and while in the act of doing so the cap was blown off, and the man so seriously scalded that he died a few hours afterwards.

The report states that judging from the appearance of the fracture, the bolt

sheet babbitt metal of high-grade is used and this is cut into strips to fit into the recess of the bronze part. Hydraulic pressure is then applied and the babbitt metal is forced into the recess and securely locked into position. The recess is dovetailed so that when the shaft revolves in it, in either direction, the babbitt cannot come out.

The bronze shell having been forced into an accurate steel die, needs no machining, and the babbitt shell is likewise accurate on account of the die used to press it into the recess. The finished or completed bearing is, therefore, ready

for use. It is used like a die cast bearing, which it really is, and slipped into place without machining or scraping.

Bearings of similar construction have been used for automobile work in France and Italy for the past ten years with excellent results, and after this length of service have been found nearly as good as new. The bronze, of course, stands a strain that a die casting will not, and in addition, the anti-frictional qualities of the babbitt with its ability to adapt itself to the shaft are also obtained.



MODERN METHODS OF ELECTRIC WIRING.

IN a recent paper on "Modern Methods of Electric Wiring," Mr. Frank Broadbent points out that for moist, steamy, and wet places, good lead-covered cables, properly installed, are hard to beat for durability and absence of leakage troubles.

It is, however, no use going to the expense of lead-covering and assuming that this is the end of it, and that it does not matter how the cables are erected and protected. Lead is a soft metal and is not self-supporting, so that, unless adequately carried throughout its length, it will, sooner or later, give trouble. To cleat lead-covered cables up to a dead wall or to suspend them from insulators just as one would support unsheathed cables is simply a waste of good material. Lead has the very useful property of forming insoluble compounds with certain acids, and a thin coating of these forms a protective covering and renders the lead sheathing impervious to further chemical action. Tannic acid is, however, not one of these acids, and lead in its presence is readily attacked, and so is unsuitable for use in tanneries or for running underground near tree roots, unless specially protected. Acetic acid is another acid which has an affinity for lead, hence lead-covered cables should not be used indiscriminately in breweries and vinegar works.



WAGES IN SASKATCHEWAN.

AT the first annual conference of the Saskatchewan Builders' Exchange in Prince Albert last week, the following wage scale was adopted: Bricklayers 70c. per hour; stone masons, 70c. per hour; stone cutters, 65c. per hour; plasterers, 65c. per hour; carpenters, 50c. per hour; plumbers and steamfitters, 60c. per hour; painters, 45c. per hour; factory hands, 45c. per hour; electrical workers, 45c. per hour.



W. T. Blaney will take charge of the mechanical department of The Motor Street Cleaning Co., of Windsor, Ont. The firm is commencing the manufacture of a motor vacuum street cleaner.

ADVANCES IN STEEL MANUFACTURE.

IN a lecture on "Recent Advances in Steel Metallurgy," delivered at the Royal Institution, Professor J. O. Arnold, of Sheffield, touched on the early history of steel, and especially the development of its manufacture in Sheffield, and described some of the more recent improvements effected by the addition of tungsten, chromium and vanadium.

He said that about 1870, which marked the first beginnings of what might be called the tungsten-chrome era in cutting-steel metallurgy, Robert Forrester Mushet, at the Clyde Works, Sheffield, began to manufacture on a considerable scale his "self-hardening steel." Mushet had practically discovered that when carbon steel was alloyed with a large percentage of tungsten, it, when cooled from a yellow heat in a draught of air, was not only sufficiently hardened, but owing to the fortifying action of the tungsten on the carbon, its hardenite was also thermally considerably more stable than that of plain carbon steel. It was probable that in Mushet's early steels the "letting-down" point of the hardenite was raised to a temperature of perhaps 400 degs. C., thus enabling engineers to take bigger cuts and work at higher speeds. Later, about 1880, Mushet still further fortified his hardenite by the addition of relatively small percentages of chromium, and between 1880 and 1900, self or air-hardening steels were produced by many steel manufacturers in considerable variety.

High-Speed Steel.

In connection with cutting steels, a profound sensation was aroused throughout the steel world when, at the Paris Exhibition in 1900, the Bethlehem Steel Co., of the United States, showed turning tools made under the alleged patent of Messrs. Taylor and White, cutting very mild steel at a speed which rendered the nose of the tool red hot. It was obvious that in these tools the thermal stability of the hardenite had been raised to perhaps 600 degs. C. The chemical compositions in the patent embodied nothing which had not been included in the Mushet type of steel for a period of about twenty years before the date of the American patent. In fact, what Taylor and White had really done was to show that this type of steel was capable of retaining its cutting edge at a much higher temperature than most engineers and metallurgists had realized. For this demonstration every credit was due to the Bethlehem Co. Sheffield steel-makers, realizing future possibilities, made from the year 1900 and onward a series of experimental researches, which eventually gave to en-

gineers that astonishing material known as high-speed steel, in which the thermal stability of the fortified hardenite was raised to about 700 degs. C.

The claims of the Taylor-White patent were the subject of a protracted law suit, the costs of which were about \$250,000, and in the end Mr. Justice Cross, of the United States Circuit Court, pronounced it to be absolutely invalid.

The Effects of Vanadium.

While the year 1870 marked the beginning of the tungsten era, and 1880 that of the tungsten-chrome era, the years 1899 to 1902 inaugurated what was destined to be the most remarkable epoch of the three—namely, the vanadium era. During these years were carried out in the experimental steel works of Sheffield University a series of researches on the influence of the comparatively rare metal vanadium on plain carbon steel and on alloy steels. Perhaps the most remarkable results in this series were the following:—

(1) A plain carbon steel, containing about 1 per cent. of carbon, had a yield point of 35 tons per square inch, a maximum stress of 60 tons per square inch, an elongation of 10 per cent. in 2in., and a reduction of area of 10 per cent. The addition to such steel of about 0.6 per cent. of vanadium raised the yield point from 35 to 65 tons, and the maximum stress from 60 to 86 tons per sq. in., still leaving an elongation of 7 and a reduction of area of 8 per cent.

(2) A steel containing 0.25 per cent. of carbon and 3.3 per cent. of nickel registered a yield point of 33 tons, a maximum stress of 42 tons per sq. in., an elongation of 26 per cent. in 2in., and a reduction of area of 53 per cent. A practically identical steel, but containing in addition about 0.25 per cent. of vanadium, recorded a yield point of 50 against 33 tons, and a maximum stress of 68 against 42 tons per sq. in., while the elongation was 17 per cent. in 2in., and the reduction of area 36 per cent.

(3) A steel containing 0.25 per cent. of carbon and about 1 per cent. of chromium registered a yield point of 27 tons, and a maximum stress of 41 tons per sq. in., together with an elongation of 36 per cent. in 2in. and a reduction of area of 55 per cent. The addition of 0.25 per cent. of vanadium raised the yield point from 27 to 40, and the maximum stress from 41 to 55 tons per sq. in. The elongation was lowered from 36 to 26, and the reduction of area from 55 to 53 per cent.

Thus vanadium differed from tungsten in having an almost magically beneficial effect, not only on cutting, but also on structural steels. In connection with vanadium steels it was an interesting

fact that the series of copyrighted and published reports issued from Sheffield University during the years 1900 to 1902 were unconscious plagiarisms of a series of American patents issued during the years 1904 to 1908. This seemed to constitute a remarkable problem in psychology.



THE HIGH SPEED ALTERNATOR.

A PAPER read before the American Institute of Electrical Engineers by B. G. Lamme contained much useful information. The author explained in simple language the reasons for the use of certain forms and proportions of the parts of the high-speed alternator. The problem of ventilation involves several elements, namely, the rate at which heat is developed, the extent of the radiating surfaces from which this heat can be removed, and the rate of flow and temperature of the air available for cooling. The losses may not be great in percentage of the total capacity of a machine, say, 3.5 per cent. out of 15,000 kilowatts, but they are large in relation to the available radiating surfaces, particularly in large units.

In the above example, the loss is 565 kilowatts, requiring, according to Mr. Lamme's calculation, 50,000 cubic feet of cooling air per minute to prevent excessive temperature rise. Not only must air pass through the cores and windings at a rapid rate, but it must come in contact with the hot surfaces. Various plans for ensuring this contact are in commercial use. Radial and axial ducts are employed, and air is forced in through the air gap and the ducts by fans on the rotor shaft or by separate blowers.



SEPARATION OF ZINC.

THE separation of zinc as sulphide in presence of acetic acid is a troublesome and tedious operation, as the precipitation is only complete after several hours, and a part of the precipitate is liable to be in the colloidal state, passing through the filter on washing with water. These difficulties may be avoided by adding to the alkaline solution of zinc, before precipitation, phenyl sulphonic acid instead of acetic acid; the liquid is then brought to boiling, and H_2S passed through it until it is quite cold. Precipitation is complete, filtration easy, and the filtrate and washings remain perfectly bright.



Industrial Accidents.—There were 491 industrial accidents recorded by the Department of Labor during January, of which 100 were fatal. The greater number of fatalities were in the mining and railway service.

The Georgian Bay Canal an Attractive Project

Considerable activity is being displayed by the opponents of the Georgian Bay Canal scheme, and while there may be justification to some extent for their attitude, the fact remains that the accompanying article contains data in favor of the project that cannot be easily combatted.

DISCUSSING the question of the Georgian Bay Canal, Sir Robert Perks, who has a vast interest in the project, made the following statement: "What is known as the Montreal, Ottawa and Georgian Bay Canal Co., possesses a charter from the Canadian Government, duly confirmed by an Act of the Dominion Parliament, authorizing this great national project. We are quite clear that once the work is put in hand, we shall in seven or eight years be through with a waterway of 449 miles, regulated by about 23 locks, having a uniform depth of 21 feet. As vessels with a draught of about 24 feet can lighten at Quebec or Montreal, it is very easy to see that we can open the waters of the Georgian Bay to the greatest ocean-going vessels which can economically ply on the Great Lakes, say, steamers of 12,000 tons.

Cost and Revenue.

The total cost will be about \$150,000,000, but for absolute safety, we are seeking power to issue bonds to the total amount of \$175,000,000. Careful averages have shown that this waterway would be open on at least two hundred and twenty days in the year, during which period we should certainly handle 18,000,000 tons of goods, including grain ore, coal, lumber, and lumber products. At a toll of 50 cents per ton, which compares very favorably with the Suez and Panama rates, we should earn an annual income of \$9,000,000. Deducting \$1,000,000 for the cost of operating the waterway, there is a net income of \$8,000,000, which is equal to 4½ per cent. on the capital sunk. We are asking the Dominion Government to guarantee 4 per cent. on our bonds, we on our part, undertaking to refund to the Government 50 per cent. of all profits over and above the amount required to pay the guaranteed interest. We offer this share of the profits to the Government, and undertake to turn out a finished canal for the amount named.

The Power Feature.

It may be asked what source of income the company can command above that derived from tolls on the tonnage. A by-product of our work will be power. Our company and also the Government, in its published report, estimate that fully 1,000,000 H.P. could be obtained at the locks, and this enormous force

could be economically transmitted by electricity for the use of the factories and mills along the route. If we only charged \$5 per horse-power we should net an income of \$5,000,000 per annum, equal to 3½ per cent. on the invested capital.

I am quite aware that it is a big investment, nor have I left out of sight the interest which must be paid on the bonds while the work is in hand, yet I say the outlay would be well justified by the result. I may add that the only reason why the company at the moment mark time is because the Dominion Government deems it well to make its own independent estimate of costs and to prepare detailed plans. The revenues of Canada are advancing at such a steady and remarkable rate that the risk to the Government is very small compared with the great commercial results certain to be obtained.

The Essence of the Scheme.

Consider for a moment what is proposed. In the first place we are about to utilize for the first time the great and direct waterway by which Providence has linked Eastern and Western Canada. We are going to give Canada the means of transporting directly to the sea the grain raised on her Western Prairies at a lower rate than is possible by any other route, and, what is more, we shall be able to draw no small amount of the grain and other heavy traffic of such great American marts as Duluth, Milwaukee, and Chicago.

Look at the map and suppose two steamers of the largest class and of the same speed to be leaving Chicago at the same time. They would, as you can see, run together until a little past the straits of Mackinaw; then they might part company, the one going to Buffalo, the American port on Lake Erie, and the other to Montreal, via the Georgian Bay Canal. While the distance between Chicago and Buffalo is 889 miles, the distance from Chicago to the entrance to the canal at French River is only 532 miles; so that as one ship has entered the canal the other has still 357 miles before it can reach its destination.

Allowing for detention at 12 locks, we find that craft making its way to Montreal will be within 284 miles of Montreal when the other has got to Buffalo, where it will still be a long way from the

sea, the rail route to New York being nearly 500 miles.

The Rates Feature.

Taking the rate to Buffalo at 1 cent per bushel, the total cost to Montreal would not exceed $1\frac{1}{2}$ cents. Briefly the cost of transit, plus the toll, would make the through-rate total from Chicago to Montreal 3 cents a bushel on wheat—a cut on existing rates to New York or Portland amply sufficient to bring as much business to the Georgian Bay route as it could possibly handle for many years.

A Developer of Industries.

This is only one side of a great question. While the Georgian Bay route is unquestionably the quickest and best all-water route among North America's internal waterways, it must also prove the mightiest instrument for developing Canadian industries which the wit of man could devise. To-day, for instance Western Canada imports American coal to the value of about \$20,000,000 per annum; but the cheap and direct carriage of the Georgian Bay route would open up a new and valuable market to the coal measures of Nova Scotia—a priceless boon to Central and Western Canada, to say nothing of the direct stimulus such a traffic would afford to Western Canadian shipments by providing return freights.

Do not forget that in the Ottawa and Mattawa Valleys there is every raw material at hand for the building up of great industries, with the one exception of coalfields, but with the hydro-electric power we could place at the command of those parts, plus the ready supply the waterway would furnish of Nova Scotian coal, the rapid industrial development of the Ottawa and Mattawa Valleys is sure and certain.

STEAM AIR JETS IN STEAM BOILERS.

THE use of steam air jets in connection with steam boilers was mentioned in a paper by A. G. Hall, chief smoke inspector of Cincinnati, read before the Cincinnati Railway Club, towards the close of 1912. He conducted a test of a horizontal return tubular plant equipped with steam air jets. A pyrometer was placed in the combustion chamber and one-minute readings were taken. Nine shovelfuls of coal were fired at intervals of about 14 minutes. In each case the temperature rose 100 to 150 deg. Fah. higher with the jets on, than with them off. Also the draught over the fire increased 0.03 in. with the jets on. With the jets on, there was no smoke, and with the jets off, the stack emitted dense smoke for a period

of 5.5 minutes after each fresh charge of coal was put on the fire.

Analysis of flue gases was made, with the following results:—With jets on, an average of 11.4 per cent. carbon dioxide, 7 per cent. oxygen, and 0.4 per cent. carbon monoxide was obtained, whereas 4.8 per cent. carbon dioxide, 14.3 per cent. oxygen, and 1.3 per cent. carbon monoxide was shown with the jets off.

LACK OF CAPITAL IN BUSINESS.

THE year 1912 was the most favorable in five years in Canada, both as regards failures and liabilities, and there the individual was charged with the responsibility for 85.3 per cent. of all failures, says Bradstreet's. Lack of capital is the Dominion's besetting business trouble, with 50.3 per cent. of all failures charged to it, as against 16.3 per cent. resulting from fraud, 5.1 per

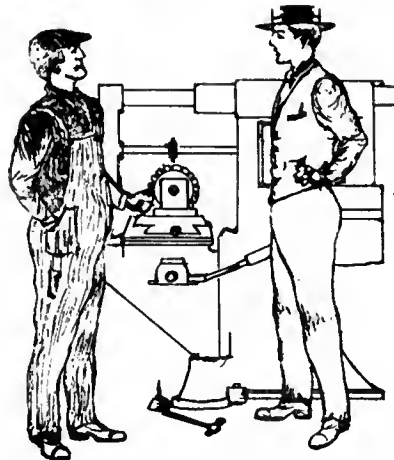

HE KNEW ALL ABOUT GEAR CUTTING!

The Green Hand: "Say, Boss, I guess this dividing head is on the bum. Shall I make it two small teeth, or one big one?"

cent. produced by inexperience, and 4.3 per cent. attributed to neglect. Specific conditions, fraud, speculation, extravagance and competition were less in their effects than in 1911, while the other personal causes were more hurtful. Specific conditions were credited with 12.8 per cent. of all failures, as against 14.6 per cent. in 1911. As regards liabilities, lack of capital, with 45.8 per cent. charged thereto, compares with 47.8 per cent. in 1911, and specific conditions were also less hurtful; but incompetence, with 22.8 per cent. in 1912 as against 18.9 per cent. in 1911, was more hurtful, as was fraud, with 10.3 per cent. in 1912, as against 9.9 per cent. in 1911, and inexperience, with 3.5 per cent. in 1912 and 1.5 per cent. in 1911.

NAVIGATION MAY OPEN EARLY.

NAVIGATION will open fully fifteen days earlier this season than in the past, according to captains and engineers

around Sarnia. While marine activities customarily are not seen until about the first of May, boats will be seen in service this year early in April. Local engineers of the Steel Trust lines expect to begin work about the first of the month. There are several conditions which make the early opening possible and advantageous. Insurance laws have been revised so that policies may be secured from April 15 instead of May 1, as in the past. Merchandise and other things which go to make up cargoes have accumulated at the various ports, and there is necessity for these being moved as early as possible. Also, the winter has been exceedingly mild, and ice will be cleared from the streams much earlier than usual.

INCREASING USE OF WROUGHT IRON.

THERE is an increasing tendency in recent construction to go back to the greater use of wrought iron as compared with steel. This tendency was referred to recently in two papers, one read before the West of Scotland Iron and Steel Institute and the other later at the Staffordshire Iron and Steel Institute by Mr. H. P. Pilkington, M.Inst. C.E., and most of the speakers agreed that this revival has been very conspicuous. The author of the latter paper referred to the fact that in the United States the reversion to iron was on a considerable scale. In Pennsylvania alone there are now fifty-three iron mills in existence and probably 200 in the States, this he attributed largely to the prevalence of rail breakages, as well as to piping and segregation. These were defects which could not possibly obtain in wrought iron. Lamination troubles, it was true, were frequent enough in the days of iron rails rolled from piles, but if rails ever had again to be rolled from iron, piling would be an obsolete institution. It is well known that because of the excessive corrosion which British railway companies have discovered in mild steel, they had now largely come to the conclusion that with regard to the rolling stock they must revert to iron, sacrificing superior strength to other considerations. There was also a marked preference shown in the demands from the Colonies for galvanized sheets of iron instead of steel, owing to the greatly lessened liability of the former to corrosion.

Sarnia, Ont.—Diver Lewis Meyers, of the Reid Wrecking Co. of Sarnia, has left with a full outfit of pumps and equipment necessary to raise the sunken steamer Manitou which sank at her dock at Owen Sound several weeks ago after being on fire.



Toronto, Ont.—A verdict by a jury, awarding John Dunlop, a riveter, \$1,500 damages against the Canada Foundry Co. for injuries received while in their employ, has been sustained by the Court of Appeal. The plaintiff had his leg broken in a hoist, and the question upon which the company appealed from the jury's verdict was as to whether, under the provisions of the Workmen's Compensation Act, the hoist in question was a machine. The Court of Appeal found that it was, and dismissed the appeal with costs against the appellants.

Cobourg, Ont.—The examination for discovery of Andrew Bashforth, the plaintiff in an action against the Provincial Steel Company, Cobourg, for salary as General Works Manager, took place here before John T. Field, local Registrar for the Supreme Court of Ontario on Feb. 7.

Toronto, Ont.—The G.T.R. appealed against the decision of Judge Hardy, awarding \$500 damages to plaintiff Stuart. The appeal was dismissed. Plaintiff brought the action to recover \$500 damages for injuries by reason of the door of a car, which plaintiff was preparing to unload, falling off, breaking his leg and inflicting other injuries, alleged to be due to defendant's negligence.

Toronto, Ont.—The Canada Foundry Co., among other industries, was fined recently for offence against the Smoke By-law. Later, Mr. Frederic Nicholls, general manager of that company, waited on the mayor, with the request that the city give reasonable time to the companies to abate the nuisance.

Toronto, Ont.—Judge Winchester on Feb. 12 awarded the Positive Clutch and Pulley Works, Ltd., \$50.93 on their claim of \$310.28 against the Hamilton Gear and Machinery Co. The plaintiffs sued to recover the purchase price of certain machinery installed by them in the defendants' workshop. The latter refused payment on the ground that the material supplied was defective. They admitted liability, however, to the extent of \$50.93. The judge held their contention that the machinery was defective. Plaintiffs' contention was that if the machinery failed to do what was claimed for it, it was because the defendants did not use it according to instructions.

Toronto, Ont.—Mr. J. S. Cartwright, K.C., sitting as Master in Chambers, on

application of Mr. H. Ferguson for the defendants, has dismissed with costs the action for libel, in which \$5,000 was claimed by the Canadian General Electric Co., against the Hydro-Electric Supply Co. The defendant company had issued a circular concerning the advantages of a certain lamp placed upon the market, but, it was contended, without belittling in any way the product of the plaintiff, as alleged.

Montreal, Que.—Ten thousand dollars for the loss of a hand, is the amount of an award made by a jury in a case wherein a workman entered suit for that sum against his quondam employer. Plaintiff was engaged as machinist-engineer and was doing some work about a machine, when a walking boss threw on the power. The engineer's hand was caught in the gearing, and was cut off at the wrist. As he was earning more than \$1,000 a year at the time, he entered action under the common law, instead of under the Workman's Compensation Act, holding the employer wholly responsible for what had occurred. As he was a young man, a father of a family, and as he represented that he was permanently incapacitated as far as his chosen field of work was concerned, he claimed the above amount. The jury, after a lengthy hearing of the case, coincided with his views all along the line, and reached a verdict as stated. Attorneys for the employer defendant, however, forthwith entered a protest against the award, and the matter will have of necessity to be threshed out before a higher tribunal, defendant maintaining that the award is wholly unwarranted by the evidence.

The suit which was that of Moise Pariseau vs. Haney Quinlan, contractors, involved some rather nice distinctions as to the exact degree of expertness which must be reasonably expected and may be strictly exacted by an employer on the part of an employee whom he has engaged as an expert in his particular line, and for whose expert services he has paid a wholly adequate wage. The circumstances leading up to the litigation are briefly, as follows:

Pariseau was employed by the Haney Co. as an engineer, working a mechanical shovel and crane in connection with the enlarging of the city aqueduct at Verdun, on March 2nd last. Pariseau went up to tighten what are known as set screws on the brasses of the crane engine. Whilst he was thus engaged, he claimed, that a foreman named Bert Manuel in the employ of Haney, and in charge of the execution of the works, set the engine in motion. Plaintiff's hand was caught in some gearing and was torn off.

In support of his claim, plaintiff con-

tended that the setting in motion of the engine was an act of gross carelessness and negligence on the part of the foreman. On the other hand, defendant laid stress on the fact that the plaintiff was the one in charge of the engine, and he was being paid high wages as a workman. The most elementary prudence in the case of such an expert hand would have impelled him to shut off the steam before going up to make repairs. If he had only done this—which it was his duty to do—the accident could not possibly have happened, no matter who might have attempted either wilfully or accidentally, to throw on the engine lever. The evidence, however, showed the work which the plaintiff had ascended to do, was a small affair, and that, under the circumstances he had not thought it necessary to shut off the steam, as the job would, in his opinion be done in a minute or so. Moreover, when he went up to do the work, there was nothing to make him think that the engine would be set in motion.

The jury in disposing of the case found the employer wholly at fault. The plaintiff had been permanently and almost totally disabled, and as he was a young man of some 32 years of age, the amount demanded was not excessive, considering the estimate made by him in the report of an actuary submitted in the case. Mr. Justice Saint Pierre, the trial judge, on motion of the defendant reserved judgment till Tuesday next. Laflamme Mitchell and Chenevert, acted for plaintiff, while Perron Taschereau Co. represented the defendant.

WIRE FENCING.

A JUDGMENT issued by the Dominion Railway Commission makes a reduction in the commodity rates on wire fencing from Montreal to the West, because, it is stated, that Montreal manufacturers have been unjustly discriminated against. The new rates from Montreal to Sarnia and Walkerville will be 22 cents; Woodstock 21 cents; to Hamilton and Toronto 18½ cents. Further West rates will be adjusted correspondingly.

C.P.R. ROLLING STOCK.

For the week ended February 13, 250 new vehicles have been constructed to the order of the C.P.R., of which six only are for replacement and the remainder are additions to the capital account. The Angus shops have turned out six flat cars, one sleeper, and one first-class smoker, also two locomotives. From other shops 240 box cars have been supplied.

The General Market Conditions and Tendencies

This section sets forth the views and observations of men qualified to judge the outlook and with whom we are in close touch through provincial correspondents.

St. John, N.B., Feb. 24.—Now that Moncton, known as the "railway town of the East," is experiencing the first touches of a "boom," the townspeople are exerting every possible effort to make things lively in the city's interests. This week there came to St. John from Moncton a delegation, composed of Mayor Gross and Aldermen Lingley and Robinson, to seek to secure from this city one of the largest local industries—namely, that of the McAvity & Sons, Ltd., interests. They were willing to offer tempting inducements to have the plants transferred to Moncton. At a meeting of their City Council a general resolution had been passed offering free water and a fixed valuation for taxation purposes for twenty years at a value of land only. The Council also authorized the Mayor to negotiate with industrial concerns with a view to interesting them in locating at Moncton, and to have him give prominence to the natural gas feature and other advantages. The firm of T. McAvity & Sons promised the delegation consideration, but no encouragement was held out that the transfer would be made.

Montreal, Feb. 24.—All markets were rather quiet last week, and there is little to report. Machinery dealers are expecting enquiries from C. P. R. for Western lines equipment, and one firm report having secured a couple of nice railway orders during the week. On the whole, however, things were rather quiet.

Money.

Bankers anticipate that the present tightness of money will be considerably relieved with the opening of navigation, since it is estimated that there are 14,000,000 bushels more grain now awaiting export than there were at this time last year. This will mean the release of an additional \$12,000,000, or thereabout, at present tied up, and should materially relieve the present situation.

Pig Iron.

Pig iron has been firm, with an average amount of business offering. English pig advanced as much as \$2.50 a ton in some cases, but few sales are recorded.

Copper and Tin.

After hardening a little in the middle of the week, copper again commenced to fall. The slump is attributed to dealers having held up the price too

long, so that when at last they had to give way the price fell rapidly. It is probable that it will go still lower before buying becomes sufficiently general to materially harden the market. Tin is also still falling.

The large output of Canadian steel mills resulted last week in a slight easing of local prices for certain lines, particularly wire rods and similar products. In other lines, however, such as bars and angles, it is still impossible to get delivery, and prices remain firm.

Toronto, Feb. 25.—Business was somewhat better last week in the machinery market. The Canadian-Fairbanks-Morse Co. have been given a rather big order for velocipedes to be used in construction work on the Grand Trunk Pacific. They also did considerable business in transmission equipment, especially belting. A. R. Williams & Co. sold several wood and iron working machines, and are still busy filling the big orders, noted in last Canadian Machinery. Foley Brothers and The Northern Construction Co., contractors for the G.T.P., gave The Williams Co. an order for two carloads of machinery to equip two machine shops at Sudbury. The International Harvester Co. and the Canadian Westinghouse Co. also placed orders with them, the latter for two boring mills.

Money.

New manufacturers seem to have little difficulty in obtaining money to start up new plants. Collections are said by supply houses to be unusually good, despite a report of money tightness which is going around.

Pig Iron.

The Canadian pig iron market is still quiet, there having been no sales to speak of from Ontario furnaces during the past week. Bookings are full for the present quarter of the year, but few over the following.

Plates, Tubes, Structural Steel.

The market is as stiff as ever, and warehouses are active. Dealers, however, have not the material to sell, and customers asking for three sizes in structural steel are usually told that stock in two sizes has been exhausted. There is a heavy demand just now for angles by manufacturers, and they are depending largely on warehouse supply, being quite willing to take sizes as near

as they can get. A Toronto manufacturer asked for certain angles last week at a certain warehouse, but was unable to obtain what he wanted. He accepted a substitute and told the firm to send over all they had. Structural men are not buying just yet, enquiries being mostly from implement and other manufacturers. The mills in the States are anxious to get all small orders on their books, so that they can handle them in bulk, and get after the big contracts.

A famine exists in steel hoops, all the mills in the United States being closed for this product, except two or three; these take orders for immediate delivery at a premium. Orders for boiler tubes are coming in rather fast. The Collingwood Shipbuilding Co. have placed big orders this week for tubes to be used on boilers now in course of construction and for repair work.

Wire.

Most of the dealers in wire and wire products had booths at the Hardware Convention at Hamilton, which closed last week-end. Considerable business was done, and several large orders for fencing placed. Other lines also sold well. Hay baling wire is in much demand, although this is not unusual.

Metals.

Copper and most of the metals continued to fall in price during the week, and little business was done. Conditions remain much the same as they were.

HIS IDEA FOR CONSUMING SMOKE.

Evening Telegraph Reporter—"What would you consider a good smoke consumer?"

Property Commissioner Chisholm—"A good smoke consumer should be arranged to suck the smoke around to the back of the fire, then draw it underneath and force it through hot coals. If this is done properly almost all the soot will be burned."

Be it noted that the above sublime effusion is not more than a couple of days old, and in its brevity and confident tone speaks volumes for the intelligence and wealth of research unfolded to the citizens of Canada's Queen City by one of her officials.

Canadian Electrical Association.

The executive committee of the Canadian Electrical Association have decided to hold their next annual convention at Fort William on June 23, 24, 25.

Everyone must see daily instances of people who complain from a mere habit of complaining.

SELECTED MARKET QUOTATIONS

Being a record of prices current on raw and finished material entering into the manufacture of mechanical and general engineering products.

PIG IRON.

	Per Ton.	
Foundry No. 1 and 2, f.o.b., Midland	\$20 50	\$21 00
Gray Forge, Pittsburg	17	15
Lake Superior, charcoal, Chicago	18	00
	Mont'l. Tor'to.	
Canadian f'dry, No. 1	\$22 00	\$22 50
Canadian f'dry, No. 2	21 50	22 00
Middlesboro, No. 3	23 50	22 00
Summerlee, No. 2	25 00	26 50
Carron, special	25 00
Carron, soft	25 00
Cleveland, No. 1	24 25	25 00
Clarence, No. 3	23 75	24 50
Jarrow	25	50
Glengarnock	26	00
Radnor, charcoal iron	30 00	34 50
Ferro Nickel pig iron (Soo)	25	00

BILLETS.

	Per Gross Ton.	
Bessemer billets, Pittsburgh	\$29 00	
Open hearth billets, Pittsburgh	30 00	
Forging billets, Pittsburgh	36 00	
Wire rods, Pittsburgh	30 00	

FINISHED IRON AND STEEL.

Per pound to large buyers:

	Cents.
Common bar iron, f.o.b., Toronto	2.10
Steel bars, f.o.b., Toronto	2.20
Common bar iron, f.o.b., Montreal	2.15
Steel bars, f.o.b., Montreal	2.25
Bessemer rails, heavy, at mill	1.25
Iron bars, Pittsburgh	1.70
Steel bars, Pittsburg, future	1.45
Tank plates, Pittsburgh, future	1.50
Tank plates, New York, future	1.61
Beams, Pittsburgh, future	1.50
Angles, Pittsburgh, future	1.50
Steel hoops, Pittsburgh	1.60

Toronto Warehouse f.o.b., Toronto.

	Cents.
Steel bars	2.30
Small shapes	2.45
Warehouse import, freight and duty to pay:	Cents
Steel bars	1.95
Structural shapes	2.05
Plates	2.15

Freight, Pittsburgh to Toronto:

18 cents carload; 21 cents less carload.

BOILER PLATES.

	Mont'l. Tor'to.	
Plates ¼ to ½-in., 100 lbs.	\$2.40	\$2.40
Heads, per 100 lbs.	2.65	2.95
Tank plates, 3-16 in.	2.60	2.60
Tubes, per 100 ft., 1 inch	9.00	8.50
“ “ 1¼ in.	9.00	8.50
“ “ 1½ in.	9.00	9.00
“ “ 1¾ in.	9.00	9.00
“ “ 2 in.	8.50	8.50
“ “ 2½ in.	10.75	10.50
“ “ 3 in.	11.95	11.50
“ “ 3¼ in.	13.95	13.25
“ “ 3½ in.	14.50	14.50
“ “ 4 in.	18.00	18.00

BOLTS, NUTS AND SCREWS.

	Per cent.
Stove bolts	80 & 7½
Machine bolts, ¾ and less	65 & 5
Machine bolts, 7-16	57½
Blank bolts	57½
Bolt ends	57½
Machine screws, iron, brass	35 p c.
Nuts, square, all sizes	4c per lb off
Nuts, Hexagon, all sizes	4¼ per lb off
Flat and round head	35 per cent.
Fillister head	25 per cent.
Iron rivets	60, 10, -0 off
Wood screws, flathead, bright	85, 10, 7½ p c off
Wood screws, flathead, brass	75, 10, 7½ p c off
Wood screws, flathead bronze	70, 10, 7½ p c off

WROUGHT IRON PIPE.

The following are Toronto jobbers' discounts on pipe. (Card weight) in effect from October 11th, 1912:

	Standard	Buttweld Black Gal.	Lapweld Black Gal.
¼ ¾ in.	63	48
½ in.	68	58
¾ to 1½	72½	62½
2 in.	72½	62½	69½ 59½
2½ to 4 in.	72½	62½	71½ 61½
4½ to 6 in.	72 62
7, 8, 10 in.	66½ 54½

X Strong P. E.

¼, ¾, 1½ in.	64	54
¾ to 2 in.	68	58
2½ to 3 in.	68	58
3½ to 4 in.	65 55
4½ to 6 in.	63½ 56½
7 to 8 in.	56½ 46½

XX Strong P. E.

½ to 2 in.	43	33
2½ to 4 in.	43 33

WROUGHT IRON PIPE.

The following are Montreal jobbers' discounts on pipe. (Card weight) in effect from October 11th, 1912:

	Standard	Buttweld Black Gal.	Lapweld Black Gal.
¼ ¾ in.	64	49
½ in.	69	59
¾ to 1½	73½	63½	72½ 62½
2 in.	73½	63½	72½ 62½
2½ to 4 in.	73½	63½	72½ 62½
4½ to 6 in.	74 64
7, 8, 10 in.	70½ 58½

X Strong P. E.

¼, ¾	64	49
½ in.	65	55
¾ to 2 in.	69	59
2½ to 3 in.	69	59
3½ to 4 in.	66 56
4½ to 6 in.	65½ 58½
7 to 8 in.	60½ 50½

XX Strong P. E.

½ to 2 in.	44	34
2½ to 4 in.	44 34

IRON PIPE FITTINGS.

Canadian malleable, 40 per cent.; cast iron, 65; standard bushings, 70; headers, 60; flanged unions, 65; malleable bushings, 65; nipples, 75; malleable, lipped unions, 65.

COKE AND COAL.

Solvay Furnace Coke	\$5.25
Solvay Foundry Coke	6.50
Connellsville Furnace Coke	5.75
Connellsville Foundry Coke	6.25
Yough. Steam Lump Coal	3.75
Penn. Steam Lump Coal	3.63
Best Slack	2.95
All net ton f.o.b. Toronto.	

OLD MATERIAL.

Copper, light	\$11.00 to 11.50
Copper, crucible	14.00 to 14.50
Copper, unere'bled, heavy	12.00 to 12.50
copper wire, unere'bled.	12.00 to 12.50
No. 1 machine compos'n	11.00 to 11.50
No. 1 comps'n turnings.	10.00
New brass clippings	9.00 to 10.00
No. 1 brass turnings	7.50 to 8.00
Heavy lead	3.25 to 3.50
Tea lead	3.50 to 3.60
Scrap zinc	3.50
Toronto dealers' purchasing prices.	

SMOOTH STEEL WIRE.

No. 6-9 gauge, \$2.35 base; No. 10 gauge, 6c extra; No. 11 gauge, 12 extra; No. 12 gauge, 20c extra; No. 13 gauge, 30c extra; No. 14 gauge, 40c extra; No. 15 gauge, 55c extra; No. 16 gauge, 70c extra. Add 60c for coppering and \$2 for tinning.

Extra net per 100 lb.—Spring wire; bright soft drawn, 15c; charcoal (extra quality), \$1.25.

METALS.

Prices in cents per pound:

	Mont'l.	Tor'to.
Lake copper, Toronto.....	16.50	15.75
Electrolytic copper, Toronto	16.50	15.75
Spelter, Toronto	6.25	5.75
Lead, Toronto	4.25	4.20
Tin, Toronto	51.00	50.00
Antimony, Hallet, Toronto	9.50	9.50
Aluminum, Toronto	22.00

SHEETS.

	Mont'l.	Tor'to.
Sheets, black, No. 28....	\$2 85	\$3 00
Canada plates, ordinary, 52 sheets	2 80	3 00
Canada plates, all bright.	3 70	4 15
Apollo brand, 10¾ oz. (American)	4 30	4 20
Queen's Head, 28 B.W.G.	4 40
Fleur-de-Lis, 28 B.W.G..	4 20
Gorbal's Best Best, No. 28	4 45

NAILS AND SPIKES.

Standard steel wire nails, base	\$2 40
Cut nails	\$2 60	2 65
Miscellaneous wire nails..	75 per cent.	
Pressed spikes, ⅝ diam., 100 lbs.	2 85

FINE STEEL WIRE.

Discount 25 per cent. List of extras.
In 100-lb. lots: No. 17, \$5; No. 18, \$5.50; No. 19, \$6; No. 20, \$6.65; No. 21, \$7; No. 22, \$7.30; No. 23, \$7.65; No. 24,

\$8; No. 25, \$9; No. 26, \$9.50; No. 27, \$10; No. 28, \$11; No. 29, \$12; No. 30, \$13; No. 31, \$14; No. 32, \$15; No. 33, \$16; No. 34, \$17. Extras net. Tinned wire, Nos. 17-25, \$2; Nos. 26-31, \$4; Nos. 30-34, \$6. Coppered, 75c; oiling, 10c.

MISCELLANEOUS.

	Cents
Putty, 100 lb drums	\$2.70
Red dry lead, 560 lb. casks, per cwt.	6.25
Glue, French medal, per lb	0.10
Glue, 100 flake	0.11
White lead, ground in oil, No. 1 pure, 100 lbs.	8.40
Tarred slaters' paper, per roll...	0.95
Motor gasoline, single bbls., gal.	24½
Benzine, per gal.	23½
Pure turpentine	64
Linseed oil, raw	58
Linseed oil, boiled	61
Plaster of Paris, per bbl.	2.10
Plumbers' Oakum, per 100 lbs..	4.25
Pure Manila rope	17

NOVA SCOTIA STEEL & COAL CO.

THE statement of the Nova Scotia Steel & Coal Co., Ltd., for the year 1912, given out after a meeting of the directors in Montreal, on Feb. 22, showed that, despite a greatly increased volume of business, profits for the year were smaller by \$18,783 than profits in 1911. The figures were \$1,000,609 in 1912, as compared with \$1,019,392 in the previous year, and \$1,140,504 in 1910.

After meeting interest on bonds, bank loans and debenture stock dividend, but before allowances for reserve funds, etc., there was a balance out of the year's profits equal to 7.96 on the common stock. This compared with a corresponding percentage on the same basis of calculation of 9.35 per cent. in 1911.

The distribution of the year's profits showed only minor changes except in interest charges. These had increased \$61,143. As a result of this increase, combined with the slight decrease in profits for the year, the company brought forward on December 31 last \$452,600, as compared with \$508,544 on December 31, 1911, a decrease of \$55,944.

STEAM BOILER REGULATIONS.

IN the new regulations for the inspection of steam boilers, which under proclamation will be brought into effect on the first of July next, practical uniformity is achieved between all the Provinces of the Dominion.

These regulations which are the product of much negotiation and considera-

tion between the representatives of Ontario, Quebec, Manitoba, Saskatchewan, Alberta and British Columbia, provide for the rigid inspection of all boilers under construction, to see that proper materials are used and safe methods of construction employed. The object is to secure a uniform standard that will insure a maximum degree of safety on the one hand, and enable a certificate granted in respect of a boiler in one Province to be accepted by any of the others. Quebec and Manitoba have not yet brought their regulations into force, but this will be done at an early date.

To carry out the provisions of the Act, Provinces will be divided into districts with a chief inspector and two or three assistant inspectors. These inspectors will be given ample discretionary power in their work, with authority to insist on a proper standard of efficiency being maintained. Hitherto, there has been no such system of inspection. Steamboat and railway boilers are not included, as these are dealt with otherwise.

The estimates for the current year will provide for the salaries of the inspectors and the necessary organization.

WINDSOR'S NEW INDUSTRY.

THE U.M.C. Remington Arms Co., who have chosen Windsor, Ont., as a location for their Canadian factory, have awarded contracts for their buildings to Windsor contractors. Construction

work will be started at once, and it is expected that one building, in which at least 50 men will be given employment, will be ready in April. Future plans for the factory have not been completed by the company. It has been decided, however, to confine operations to the manufacture of cartridges for the present and, it is expected that a plant requiring several hundred employes will be completed in the near future.

The plant at the start will consist of one two-storey manufacturing building, approximately 125 by 50 feet in dimensions, fully equipped with the most modern automatic machinery, safety devices and fire protection apparatus; also a one-storey building, 140 by 16 feet, for the purpose of housing delicate instruments and testing devices.

The Power House.

In addition there will be a power house, equipped with necessary boilers and pumping machinery, and three powder magazines, each 9 by 10 feet. The magazines are constructed with special ventilating systems and lightning arresters, and are surrounded by large and carefully designed earthwork embankments, affording complete protection.

The Remington Arms-Union Metallic Cartridge Company own the Remington Arms works, at Ilion, N.Y., and the Union Metallic Cartridge works at Bridgeport, Ct. In Bridgeport the Union Metallic Cartridge Company has the largest ammunition factory in the world.

The MacLean Pub. Co., Ltd.

(ESTABLISHED 1888.)
 JOHN BAYNE MACLEAN - - - - - President
 H. T. HUNTER - - - - - General Manager
 PUBLISHERS OF

CANADIAN MACHINERY AND MANUFACTURING NEWS

A weekly newspaper devoted to machinery and manufacturing interests, mechanical and electrical trades, the foundry, technical progress, construction and improvement.

H. V. TYRRELL - - - - - Business Manager
 PETER BAIN, M.E. - - - - - Editor
 J. H. WILLIAMS - - - - - Associate Editor

OFFICES:

CANADA

Montreal, Rooms 701-702 East-
 ern Townships Bank Bldg.

Toronto, 143-149 University
 Ave., Phone Main 7324

Winnipeg, 34 Royal Bank
 Bldg., Phone Garry 2313

Vancouver, H. Hodgson 2649
 Third Ave. West.

GREAT BRITAIN

London, 88 Fleet Street, E.C.
 Phone Central 12960
 E. J. Dodd

UNITED STATES

New York, R. B. Huestis
 115 Broadway, New York,
 N.Y., Phone 2209 Rector

Chicago, A. H. Byrne
 Room 607, Marquette Bldg.
 140 S. Dearborn St., Chicago

CABLE ADDRESS:

Macpubco, Toronto. Atabek, London, Eng.

SUBSCRIPTION RATE:

Canada, \$2.00; United States, \$2.50; Great Britain, Australia and other colonies, 8s. 6d. per year; other countries, \$3.00. Advertising rates on request.

Subscribers who are not receiving their paper regularly will confer a favor on us by letting us know. We should be notified at once of any change in address, giving both old and new.

Vol. IX. FEBRUARY 27, 1913 No. 6

PRINCIPAL CONTENTS.

Points to be Observed in the Organization of the Factory	191-192
Regulations Concerning Apprenticeship	192-193
General	193-194
Iron and Steel Trade in the United States...A Barometric Condenser...To Stop the Loss from Fire...Sugar Refinery at St. John, N.B.	194-195
Engineering Prospects in the Dominion of Canada	195-196
Demurrage Rates Up Again	196
The Design and Operation of Special Chucks	196-198
General	198
The World's Iron Resources...Electric Locomotives Insulating Concrete Roofs.	198-199
Notes Concerning Drafting Room Methods	199-201
Canadian Railroad Extensions and Betterments	201-202
G.T.P. Construction for 1913...C.N.R. Programme for 1913...New Way of Getting a Spur...Examination of Underside of Rail Heads...C.P.R. Will Spend \$16,000,000...Railways in Alberta...Customs Revenue Increase...Canada Brick Co....Canadian Car and Foundry Co.	202-203
Machine Shop Methods and Devices	203-204
Improvised Tap Wrench...A Feeler...Pitching Propellers...Speed Plate for Drill Presses...Jig for Facing and Ladling Connecting Rods...Protection of Alternators.	204-205
Developments in Machinery	205-207
Heavy Duty 18-Inch "Mueller" Engine Lathe...Motor Driven Combination Punch and Shear...A New Lufkin Rule...Duplex Milling Machine...Testing a Micrometer...11 and 16-Inch Motor Driven Lathes.	207-208
Foundry Practice and Equipment	208-209
Notes on a Bedded-In Job...Machine for Recovering Metal from Fumes...Specifications for Automobile Bronzes.	209-210
General	210-212
New Safety Device for Rolls—Tightening Hand-hole Covers Under Steam Pressure...Process for Babbitt-lined Bronze Bearings...Modern Methods of Electric Wiring...Wages in Saskatchewan...Advances in Steel Manufacture...The High Speed Alternator...Separation of Zinc.	212-213
The Georgian Bay Canal an Attractive Project	213-214
General	214
Steam Air Jets in Steam Rollers...Lack of Capital to Business...Navigation May Open Early...Increasing Use of Wrought Iron.	214-215
Recent Judicial Decisions	215
The General Market Conditions and Tendencies	215
Editorial	218
Industrial and Construction News, Etc.	219

STEAM BOILER REGULATIONS.

AN announcement will be found on another page to the effect that an agreement has at last been reached on the question of uniform steam boiler rules and regulations for the various provinces of the Dominion. Boiler manufacturers, and, in fact, everybody directly or indirectly concerned will welcome the decision, putting an end, for ever, as it does, to the opportunity for the exercise of petty and personal fads and fancies by local authority "experts."

SMOKE CONSUMING.

THE smoke nuisance question in our cities and towns has always been reckoned a hardy annual; it may, however, default and sully its past record in the near future, if the result of a diagnosis of its symptoms and nature, and the propounding of a cure for its treatment by the property commissioner of Toronto, be a criterion. On another page of this issue will be found the essence of an interview by the above gentleman, after reading which, it may help somewhat to indicate the trend of intelligence as we find it operative in much of the administration of cities and towns, and perhaps strengthen our already well founded opinion that there is a plethora of the "square plug in the round hole" expert in evidence.

TEMPTING OFFERS DECLINED.—WHY?

WITHIN the past few weeks, quite a number of tempting offers to more remunerative appointments have been declined by those to whom they were extended, and in view of the fact that the spheres concerned are more or less diversified in their scope, an interesting question is raised as to the motive or motives which prompted the refusals in each case.

At the moment, three instances of more lucrative positions declined come to our mind. One of these involved a well known Toronto clergyman, another the Principal of the Technical School, Toronto, and the third, an assistant engineer in the employ of the Corporation of Toronto. Beyond all question, from a salary point of view, the word "tempting" is alone applicable, and there are few indeed bold enough to say otherwise, in this highly material age, than that they are not in the business for the pecuniary reward which it will bring. While it is true that every man knows his own mind best, and should be capable of minding his own business, a motive or motives, a reason or reasons entered into the decisions in these various instances that the recipient of the offer had better stay at home.

Can it be that Toronto is "easy street," and that mediocre ability passes there for that of an expert. Again, there are those, and they are sometimes right, who tell us when a good offer to move comes along, that "we know where we are, but don't know where we are going." Advice like this crowds around us as thick as leaves on a tree in June, and were many of us to heed it seriously, progress and ambition would get a serious setback. A change of position, tempting salary or otherwise, has wrecked many a career, which shows that careful consideration should be given every proposition offered. At the same time, there is such a thing as "playing the man," and be assured that when an offer of twice, three or four times our present salary comes along, it is a call to "play the man," no matter whose graveyard the position may have been previously, and if we don't accept, we are poorer financially, and what is truly of greater moment, also stunted in manliness.

INDUSTRIAL ^A_N^D CONSTRUCTION NEWS

Establishment or Enlargement of Factories, Mills, Power Plants, Etc.; Construction of Railways, Bridges, Etc.; Municipal Undertakings; Mining News.

Engineering

FOUNDRY AND MACHINE SHOP.

Brandon, Man.—The Canadian Gas Generator Company, Ltd., is said to be planning to erect a factory.

St. John, N.B.—Messrs. T. McAvity & Sons, Ltd., may erect their foundry on some land which they bought recently.

Battleford, Sask.—Machinery is being installed in the new factory of the Laurentia Milk Co. Mr. Goodhand is the manager.

Winnipeg, Man.—A contract for turbines at \$27,847 each, has been let to Escher Wyss & Co., of 514 Canadian Express Building, Montreal.

Cobalt, Ont.—The 5-stamp mill at the McEnaney Mine will be converted into a 20-stamp mill, and an addition for cyanide treatment will be added.

Welland, Ont.—Goodwillie will instal two 75 h.p. boilers, electric elevators and motors in his new canning factory. He is building a 125 ft. chimney.

Windsor, Ont.—Announcement is made that the United States Steel Trust will start operations on its \$20,000,000 plant below Sandwich in the spring.

New Westminster, B.C.—A plant to cost \$35,000 will be erected at Queensborough, for The Heaps Engineering Co., Vancouver. Machinery is required.

Vancouver, B.C.—A Vancouver construction firm will erect a large steel plant at Port Moody, B.C., in the spring. The transfer of property is not yet complete.

North Bay, Ont.—Alterations are being made to the Trout Lake Smelter, recently purchased by the Iron Smelters Co., Toronto. J. Island is superintending the work.

Three Rivers, Que.—The Brunelle Boiler Co., Worcester, Mass., has been reorganized, and will remove its plant from Worcester to here. Arthur Heroux, Yamachiche, Que., is treasurer of the company.

Wilkie, Sask.—Tenders will be received at the office of the division engineer of the C. P. R. at Moose Jaw, Sask., up to March 1st., to supply labor and material to build a boiler and machine shop at Wilkie.

Port Arthur, Ont.—The Canadian Northern Coal and ore Dock Co. will build a dock east of their plant 500 feet wide, and will add much new machinery. A new boiler is required.

Moncton, N.B.—Messrs. Abrams & Son state that their machine shop, which was wrecked by an explosion, will be rebuilt as soon as the insurance is adjusted. The loss is estimated at \$15,000.

Winnipeg, Man.—The business of the Winnipeg Tool and Forging Co. has been purchased by Luther Holling, recently a tool expert in the Winnipeg shops of the Canadian Pacific Railway, who will begin the manufacture of some new lines of goods.

Moncton, N.B.—At the annual meeting of the Record Foundry and Machine Co. last week, it was decided to dispose of the Montreal plant, which is now practically closed, and to concentrate manufacturing at Moncton. Mgr. W. C. Hunter reported business good.

Port Colborne, Ont.—Employees of the Dominion Bridge Co. have commenced work on the Government elevator, which is to be enlarged. The conveyors have to be taken down, and other parts removed before any of the new work can be commenced.

Goderich, Ont.—Goderich will vote on an industrial proposition by Rice-Knight, Ltd., of Toronto, manufacturers of electric fixtures, etc. They will erect a factory of 10,000 square feet floor area, worth \$40,000. A guarantee of bonds is asked for \$20,000, and fixed assessment of \$10,000 for ten years. The company is to employ not less than 30 hands at the start, to be increased to 50. H. W. Knight is the president.

Fort William, Ont.—J. H. Plummer, president of the Dominion Steel Corporation, has purchased 45 acres on Island No. 1, with 2,000 feet frontage on the Kaministiquia River, at a price stated to approximate \$250,000. It is considered likely that the Dominion Steel interests may contemplate development of the iron deposits of the neighborhood by establishing furnaces, etc.

Welland, Ont.—The Standard Steel Construction Co. expect to have their large plant in operation next month. They have already secured a very satis-

factory list of orders. They will supply the structural work for the new Canada Forge plant, and also for the large plant of Samuel May in Toronto. The company has secured the following constructions: Sub-station at Brantford for Hydro-Electric Power Commission, yard crane runway for Page-Hersey at Guelph, two bridges for McKenzie & Mann Co. to be erected on the Toronto and Eastern Railway.

Sault Ste. Marie, Ont.—News that the Dominion Nickel and Copper Co. will erect nickel smelters at a cost of \$5,000,000, four miles east of Sudbury, on the line of the Algoma Eastern Railway, leaked out here on February 22, following negotiations between the nickel company and the railroad in the matter of sidings. Surveyors were on the ground last week, and it is aimed to have the work completed in one year. The company will also put in its own lines from the nickel property to the Algoma Eastern, which will benefit by the haul to the smelter.

Electrical

Stratford, Ont.—An extension to the electric lighting system is planned by the City Council.

Farnham, Que.—A stationery manufacturing plant is contemplated for F. Evans, of Montreal.

Bradford, Ont.—This village and West Gwillimburg have voted in favor of Hydro-Electric power.

Gananoque, Ont.—Improvements are to be made to the local plant of the Electric Light and Water Power Co.

Ottawa, Ont.—A sub-station to cost \$75,000, for Ottawa Electric Railway Co., including construction of building and equipment is planned.

Calgary, Alta.—An order for twenty-four double truck p.a.y.e. cars was recently placed with the Ottawa Car Co. for the Municipal Street Railway.

Collingwood, Ont.—Hydro-electric power was turned on here a week ago. It is being developed on the Severn River by the Simeoe Light & Power Co.

Fort William, Ont.—The utilities committee of the city council recommends a

reduction in price of electric current supplied for cooking purposes from 3 to 1½ cents per kilowatt hour.

Hamilton, Ont.—Mayor Allen says another by-law for \$100,000 more for the extension of the civic power plant will soon be submitted. The awarding of contracts for meters has been deferred.

Newmarket, Ont.—An expert from McGill University is advising the town council whether to take power from the Hydro-Electric Co. or the Metropolitan Rly. He is doing the same for Aurora, Ont.

Hamilton, Ont.—The city hydro engineer has recommended that the tender of an English firm for meters be accepted. The contracts were not let, the suggestion being made that a local firm get them.

St. John, N.B.—The New Brunswick Hydro-Electric Co. will seek power to increase its capital stock, and to purchase the property of any company producing electric current. Slipp & Hanson, solicitors.

Ottawa, Ont.—The city council will apply to the Ontario Railway and Municipal Board for authority to issue debentures for \$150,000 to provide for enlarging the plant of the municipal electric plant and the present building.

Toronto, Ont.—The Toronto Electric Light Company will deliver direct current to their customers instead of alternating. They will have four lines from Niagara instead of one. In the centre of the city, all wires will be placed underground.

Vancouver, B.C.—The Western Canada Power Co. will increase its power installation on Stave River from 25,000 h.p. to 50,000 h.p. capacity, and afterwards in about three years, add a second 50,000 h.p. installation. Mr. C. H. Cahan, K.C., of Montreal, is interested.

Gull Lake, Sask.—The new electric light plant is nearly complete. A gas engine is installed, and was supplied by the British Canadian Engineering Co., Winnipeg. The same firm supplied the dynamo, exciter, switchboard and gas producer. Mr. F. W. Publow will superintend the plant.

Montreal, Que.—At the annual meeting of the Shawinigan Water and Power Co. a statement was presented showing the gross earnings for 1912 to be \$1,569,671, and net to be \$872,360. The latter is an increase of \$119,000 over the figures for 1911. The paid-up capital of the company is now \$11,000,000. The old Board of Directors was re-elected.

Sackville, N.B.—The Jordan Memorial Sanatorium at River Glade, N.B., will

erect a concrete power house. This will include incinerator, boiler room, engine and dynamo room. The dynamo engines and boilers will be installed now. Plans and specifications may be seen at the office of the Summer Co., Moncton, N.B., and of F. N. Brodie, architect, St. John, N.B.

Montreal, Que.—According to the Schenectady, N.Y., Gazette, the Cedar Rapids Hydraulic Co. has placed an order with the General Electric Co. for machinery which will necessitate the outlay of about \$1,000,000. The present order consists of twelve 10,000 kilowatt turbo-generators of special make and design. The machinery will be installed in a new plant at Cedar Rapids on the St. Lawrence River.

Montreal, Que.—Mr. C. H. Cahan announces that his recent mission to England was successful. He stated that a contract had been entered into with the British Columbia Electric Railway Co., Ltd., for the sale of a large quantity of electric power to that company on satisfactory terms. The contract commences with a supply of a maximum of 12,000 horsepower on September first next, increasing to a maximum supply of about 40,000 horsepower upon the completion of the Western Canada Power Co. second installation.

Motor Car Industry

Hamilton, Ont.—The Schacht Motor Car Co. is reported to have been taken over by a Toronto company. The name will be retained.

Strathroy, Ont.—The Royal Motor Car Co. will build their plant, the town agreeing to lend them \$25,000. Fifty hands will be employed, increasing to 200.

Toronto, Ont.—Notice that the British automobile manufacturers will invade the Canadian field was given at the Toronto Automobile Show, last Saturday, by Mr. George Williams, of London, colonial and foreign representative of the Society of Motor Manufacturers and Traders, Limited, of England, who is in Canada to make a report on the conditions and the ultimate success of the venture.

General Industrial

Port Hawkesbury, N.S.—The North Atlantic Fisheries Co., whose plant was destroyed by fire, will rebuild.

Estevan, Sask.—Roger Miller & Son, of Vancouver, contemplate establishing a large brick-making plant at Estevan, Sask.

Preston, Ont.—A factory for the Anchor Mfg. Co., Niagara St., Toronto, is to be built and will include a machine shop.

Springfield, Ont.—A new factory, 50 x 200 feet, three storeys high, will be built for the Condensed Milk Company in the spring.

Kamloops, B.C.—Mr. Wm. McDonald will establish a plant for manufacturing cement blocks, bricks and tile, if helped by the Town Council.

Port Perry, Ont.—The bonds of a canning company, who will erect a factory here, have been guaranteed by the ratepayers for \$7,500.

Lethbridge, Alta.—The new creamery to be installed here will include a sterilizer among its equipment. Work will commence very soon.

Montreal, Que.—The Canada Auto and Taxi Co. has gone into liquidation. The assets of the company are forty cars and a garage and outfit.

Toronto, Ont.—Fire did \$4,000 damage last week to the plants of John Carey & Co., leather goods makers, and Sheppard & Co., carriage makers.

Toronto, Ont.—John B. Payne & Co., Pearl Street, have purchased a site on Eastern Avenue for \$6,000, where they will erect a \$16,000 chemical factory.

Hamilton, Ont.—An addition to their factory to cost \$14,000 is planned for the Laidlaw Bale Tie Co. The builder and contractor is Geo. E. Mills, King Street East.

London, Ont.—At the village of Delaware, 13 miles away, quite a pressure of natural gas has been discovered, and if a sufficient quantity is obtainable it will be piped to London.

Nanaimo, B.C.—The Western Fuel Co. will improve the facilities in its mines to produce 1,000,000 tons of coal in the Nanaimo field in 1914. Thomas Stockett is general manager.

Leduc, Alta.—A company will erect a \$16,000 flour mill, with a capacity of 75 barrels, and a grain elevator. A free site is asked for. The Board of Trade favors the proposition.

Markham, Ont.—The Ontario Yarn Company, whose plant was partially destroyed recently by fire, will spend \$8,000 on additional machinery and \$40,000 in rebuilding their plant if the village will lend them \$20,000.

Pembroke, Ont.—A concern manufacturing steel office equipment have purchased the machinery, patterns, patents, etc., of another company, and will build

a plant in Pembroke if given a loan, a site and fixed assessment.

Thorold, Ont.—The Ontario Paper Co.'s plant will commence operations early in June with a capacity of 110 tons. Medill McCormack, of Chicago, owns the concern. The plant will be fed from Anticosti Island.

Sarnia, Ont.—At the annual meeting of the Board of Trade last Thursday, the Board decided to pledge itself for half the amount necessary for securing industries, the other half to be raised by the Town Council.

Calgary, Alta.—The Alberta-Saskatchewan Paper and Strawboard Products Co., Ltd., Calgary, are preparing to erect a plant at Medicine Hat, Alberta, on a site selected some time ago. It is the intention to build the plant in units.

Medicine Hat, Alta.—J. A. Dailey, Herre Haute, Ind., will erect a large brick and clay products plant at Medicine Hat, Alberta, at a cost of \$150,000. Between 100 and 150 men will be employed. Winnipeg and Regina men are expected to find the capital.

Saskatoon, Sask.—The Northland Milling Co., of Larimore, N.D., will erect for the 1913 crop a mill here, having a capacity of 1,000 barrels, also a 60,000-bushel elevator and a two-storey flour house. Work will commence in April. C. H. Mohr, Minneapolis, will erect the mill.

Medicine Hat, Alta.—The City Council has an offer from the Hunt Engineering Company, who propose to erect a large cement plant south of Medicine Hat, to build a steel and cement bridge over Seven Persons Creek at a cost of approximately \$100,000, and give the city free use of it for three years and the option to buy it at net cost any time in two years if the city will give roadway and right for a boulevard through industrial site.

Sarnia, Ont.—According to a report which has leaked out from the oil circles here, the Imperial Oil Company has purchased another large piece of land, upon which it is proposed to construct an immense factory, which will employ 150 men, and in which will be turned out Rayo lamps and oil stoves of various descriptions. The company at its recent meeting voted on a by-law to give the officials power to engage in this line of business. The annual meeting of the company was held recently, but so far nothing has been given out to the press.

Municipal

Nelson, B.C.—The purchase of a motor ladder truck is being urged.

Toronto, Ont.—A fire hall will be built and equipped at the corner of Roneesvalles and Wright Aves.

St. Thomas, Ont.—Additional equipment for the fire department is being ordered to secure Class A. rating.

Peterborough, Ont.—A by-law for \$90,000 or more for a sub-fire station will be submitted to the people shortly.

Lethbridge, Alta.—The medical officer of health has recommended the erection of a public abattoir and an incinerator.

Macklin, Sask.—The town council is considering the installation of a waterworks and sewerage system. Robert Orr is the secretary-treasurer.

Portage la Prairie, Man.—The by-law to raise \$35,000 for the purpose of constructing bridges throughout the municipality will be submitted to the burgesses for ratification on March 10.

Fairbank, Ont.—Local tests of different chemical and steam fire engines will shortly be held. Following this, the York Township Council will be urged to grant an amount to assist in the movement to prevent fires.

Gananoque, Ont.—It is proposed by the council to submit a by-law to the ratepayers at an early date whereby \$25,000 will be raised to guarantee the bonds of Cowan & Britton, Ltd. In return for same, said company will spend \$50,000 on improvements to present plant.

Moose Jaw, Sask.—The following by-laws will shortly be submitted to the burgesses:—\$10,000 to beautify parks; \$33,000 for improvement of roads; \$75,000 fire-fighting apparatus; \$185,000, extension of electric power system; \$30,000 new sub-station; \$16,500, educational requirements; and \$150,000 extensions to water works system. Total, \$499,000.

Railways—Bridges

Bridgeburg, Ont.—The G. T. R. are spending \$100,000 enlarging and extending their northern yards here.

Victoria, B.C.—The blacksmith's shop was destroyed in a fire at the sheds of the Victoria and Sidney Railway recently.

London, Ont.—The Pere Marquette Railway have tendered for the purchase of the London and Port Stanley Rail-

way. The G. T. R. declares it has no interest in the property.

Medicine Hat, Alta.—A steel and concrete bridge, 1,100 feet long, will be built to connect Seven Persons Creek with this city.

Hamilton, Ont.—It is reported that the G. T. R. will spend about \$1,000,000 in this city this year, and that plans are nearly complete.

Port Arthur, Ont.—The C. N. R. will increase the capacity of its engine house. There are at present 24 stalls, and 10 more are required.

Fredericton, N.B.—The contract for the superstructure of the arch bridge to replace the suspension bridge at St. John has gone to the Dominion Bridge Co., of Montreal, for \$275,000.

Sudbury, Ont.—The C.N.O. Ry. Co. has been authorized to construct bridges (1) across Goose River, District of Sudbury; (2) across Kabinakagami River, District of Algoma, Ont., and also across Jackfish River.

London, Ont.—Shareholders of the Woodstock, Thames Valley and Ingersoll Electric Railway have directed Gibbons, Harper and Gibbons, of this city, to apply for the appointment of a receiver for the road.

Toronto, Ont.—York Township Council requires a concrete bridge at York Mills, costing \$6,000. It will be 65 ft. long, 13 ft. deep and 14 ft. roadway. Tenders will be called for soon by Engineer Frank Barber, York Mills.

Welland, Ont.—The Street Railway Co. will build West Main and North Main Street sections in the spring. The East Main Street line will be extended to Rosedale. C. J. Laughlin is vice-president.

Toronto, Ont.—The Forest Hill Road Electric Railway Co.'s application for a charter to construct and operate lines on Forest Hill Road, Eglinton Avenue and Dufferin Street, will be opposed by the city, as it may interfere with the city's transportation plans.

Guelph, Ont.—The plans of the C.N.R. entry into Guelph with the lines of the Toronto Suburban Railway have been filed with the city solicitor, and will be presented at the next city council meeting. Construction will start in the spring as soon as the frost is out of the ground.

Fort Erie, Ont.—The Buffalo and Fort Erie Ferry and Railway Co. will increase their capital stock, "for the purpose of electrifying the railroad and for other purposes." The company may extend its line to Bridgeburg and con-

nect with the electric line from Port Colborne.

Water-Works

Village De Courville, Que.—A waterworks system is planned by the municipal council.

East London, Ont.—A flour mill costing \$40,000 will be erected for T. Dexter, North Branch Mills, West London.

Galt, Ont.—An extension of the waterworks system to cost \$15,000 is planned by the council. The work will be done by the town.

Montreal, Que.—The biscuit factory of the McCormick Biscuit Co., 32 St. Didier Street, which was burned, will be rebuilt at once.

Uxbridge, Ont.—Waterworks supplies are required including a 35 h.p. water wheel, 1 steel pipe for penstock and 40 rods of 6 in. cast iron pipe.

Lethbridge, Alta.—The town is considering establishing a gravity waterworks system. A 50-mile line would be required. Surveys are being made.

Kerobert, Sask.—Work on the waterworks system will be done by day labor. W. D. Lambert, superintendent, will secure the necessary tools. In the spring the power house and pipe lines will be ordered.

Winnipeg, Man.—The Board of Control have instructed the city engineer to proceed at once with the sinking of six more test wells for the waterworks system.

Lacombe, Alta.—Waterworks and sewerage systems are planned by council. The engineer R. E. McArthur, Lethbridge, is preparing plans and will report on both systems.

Weyburn, Sask.—The Council will spend \$220,000 this year on sewerage works, waterworks and extension of electric light system. A new city hall and fire hall will be erected.

Burk's Falls, Ont.—An extension of the waterworks system to cost \$8,000 is planned by the town council. The clerk is McArthur. A by-law has been passed and work will start in June.

Bassano, Alta.—The citizens on Feb-21 will vote on a by-law authorizing the town to borrow \$100,000 to be spent on a complete waterworks system, a system of town sewers and an outfall sewer system.

Dunmore, Alta.—A water system from the South Saskatchewan River through a main 10 inches in diameter will be installed. Tenders have been called.

C. R. Ross, of Medicine Hat, Alta., is interested.

Tofield, Alta.—The fittings for the pumping plant at the reservoir have arrived, and the plant should soon be ready for operations. The government-owned steam boiler has been rented to supply steam to drive the pumps.

Leaside, Ont.—The C.N.R. subdivision is to have a waterworks system with a capacity of 250,000 gallons, the water to be obtained from springs. The cost will be between \$75,000 and \$100,000. Work may start on it in the spring.

Sydney, N.S.—At the plebiscite on January 28 the ratepayers approved money votes including: \$40,000 for new water main, \$10,000 for paving streets and \$72,000 for new hospital; also \$106,000 for a pumping station to supplement water supply.

Transcona, Man.—The council is considering joining other municipalities in securing a supply of soft water, the incorporation of areas to be known as the Greater Winnipeg Water District. The source from which the water would be secured has not been named.

Winnipeg, Man.—Tenders will be received by the chairman of the Board of Control up to March 3 for the supply of the construction plant and performance of all labor necessary for the construction of a reservoir, having a capacity of 18,000,000 Imperial gallons.

Edmonds, B.C.—Tenders will be received by Comptroller W. Griffiths until March 3rd, 1913, for about 15 miles of steel water pipe varying in diameter from 3 ins. to 10 ins. The engineers are Cleveland & Cameron, Vancouver, B.C.

London, Ont.—Thirty-one applications for the position of city engineer were opened by the Board of Works last Thursday, but an appointment was deferred until a later date. The Board eliminated all but ten names from consideration.

Vancouver, B.C.—Water pipe supply of 5,280 lin. ft. of 2-in. galv. iron pipe with unions; 107,000 lin. ft. of 4-in. No. 8 lapwelded or weldless steel pipe; 50,000 lin. ft. of 8-in. No. 7 lapwelded or weldless steel pipe are required. Tenders received until March 5, 1913.

Berlin, Ont.—The largest standpipe on the continent was filled for the first time on February 18, by the Water Commission. The tank has a capacity of five hundred thousand gallons, and is supported by a reinforced concrete shell twelve inches thick and eighty feet high, resting on a circular foundation thirteen feet in diameter. The entire structure is 125 feet high, and cost about

\$35,000. It was erected to increase the water pressure for fire protection.

Wood-Working

Walkerton, Ont.—A sash and door factory to cost \$7,000 is planned for R. Truax & Son.

Thorold, Ont.—The Graneville Board and Pulp Co. have closed their factory here and intend moving the plant to Penetang, Ont.

New Westminster, B.C.—The Canadian Wheel and Wagon Co. will erect a factory near the Fraser Mills. W. F. Pettit is the managing director.

Selkirk, Man.—The planing mill of Capt. Wm. Robinson, was burned recently while closed down for the purpose of substituting electric motors for steam power. It will be rebuilt at once.

Parry Sound, Ont.—The Sieman Company, Limited, it is believed, will start a branch concern here, rebuilding on the site of the old Veneer factory. They would make hardwood flooring and furniture.

Building Notes

Montreal, Que.—The Methodists will erect a new college building, costing \$300,000.

Toronto, Ont.—Mr. Jas. Ryrie will build a 2½-storey brick residence and private garage to cost \$50,000.

London, Ont.—Surveys have been commenced for the enlargement of St. Joseph's Hospital. A \$50,000 addition will be built this spring.

Fort William, Ont.—The tender of M. H. Braden for the building of the new grain exchange has been accepted. His price is \$275,000.

Regina, Sask.—The Pioneer Tractor Company will build a large warehouse, and will handle the business for the province from this city.

Ottawa, Ont.—The Methodist Church will build on the Glebe, Lyon St., at a cost of \$150,000. Tenders are being called. Rev. Basil Thompson is in charge.

Toronto, Ont.—School section 28 Mount Dennis, has authorized the issuance of debentures to the extent of \$37,500 to be used in the building of an up-to-date school.

Toronto, Ont.—Work will commence on May 1 toward the demolition of the old buildings to make room for the new



A Building Protected

The possibility of a disastrous fire in this splendidly built and equipped building has been wisely reduced to a minimum—through the installation of

Manufacturers' Automatic Sprinklers

Insurance premiums, too, are remarkably low, because the Underwriters are glad to acknowledge the protection offered by our unsurpassed System.

As a matter of economy in insurance, to say nothing of the real protection from fire, you should install our sprinkler system in your factory, shop and office.

The General Fire Equipment Co., Ltd., 72 Queen Street East Toronto

CAST STEEL CASTINGS

Acid Open Hearth Steel for Locomotive and Machinery Castings.

Stock Process Steel for Automobile and Light Castings of all descriptions.

Prompt Deliveries.

(Annual Capacity, 12,000 tons.)

Let us figure on your requirements.

The Dominion Steel Castings Company, Limited
HAMILTON, ONTARIO

ten-storey building of the Trusts and Guarantee Company. The building is to cost about \$250,000.

Bridgeburg, Ont.—Work will be started in the spring on a cement block factory for the Mentholatum Company; a \$60,000 plant for the Bailey-Tuttle Company; an \$18,000 Methodist Church, a \$10,000 telephone building; an enlarged Michigan Central station, and work of erection is now in progress on a \$10,000 planing mill.

Marine

St. John, N.B.—The length of the new drydock will be increased from 900 to 1,100 feet.

Fort William, Ont.—The Western Terminal Elevator Co. will erect a million bushel annex to their plant, costing \$400,000.

Fort William, Ont.—The Richelieu & Ontario Navigation Co. will construct a wharf and the initial unit of a freight shed system, costing half a million.

Vancouver, B.C.—The Furness steamship lines of Liverpool and London, have decided to start a new service between Vancouver and London via the Panama Canal.

Victoria, B.C.—The B.C. Marine Rly. are lengthening the Union steamer Cheslakee, now lying at Esquimalt. Twenty-eight feet will be added in the middle. The boat recently foundered.

Panama Canal.—The official announcement was made on February 20 that on account of the late slides, five million cubic yards of material must be added to the figures for excavating.

St. John, N.B.—The Norton Griffiths Dredging Co. will begin work in Courtney Bay in April. The breakwater is being pushed 1,800 feet into the bay. Steam shovels will soon be working on the site of the drydock.

Montreal, Que.—The president's annual report of the Richelieu and Ontario Navigation Co. refers to the ordering of a new boat from the Western Dry Dock Co., of Port Arthur, for the Canadian North-West traffic.

Fort William, Ont.—Mr. Alex. Reid, of the Western Terminal Elevator Co., Fort William, states that a one million bushel annex will be made to the present elevator system of that company and that the cost would be approximately \$400,000.

Kingston, Ont.—The Kingston Shipbuilding Co. has received a contract to build two dump scows of 500 cubic yards each for the Dominion Govern-

ment. They will be constructed of steel throughout, and will be used by the Department of Public Works.

Collingwood, Ont.—The Chicago & Duluth Transportation Co. will run the new steamer 'North American' from Chicago and Duluth to Collingwood. The shipbuilding company's plant is filled with contracts for about 12 months ahead, and is employing almost 1,000 hands.

New Westminster, B.C.—The Pacific Dredging Co., owning three dredges and accessories, have decided on Fraser River as their base of operations, and have purchased nine acres adjoining the property of the Coquitlam Shipbuilding and Marine Co., where they will erect a machine shop, marine slip, and offices.

New Westminster, B.C.—Contracts for the three scows to be used in connection with the harbor scheme have been awarded to Messrs. Stead, Parsons and Ross, of this city, at \$4,825 each, delivery to be made within seventy-five days. Messrs. Waugh, Wesener and Bailey were awarded the contract for the construction of the cedar pile quay wall.

Montreal, Que.—Mr. G. B. Hunter, of Wallsend, and Mr. F. D. Caws, of Sunderland, members of two large English shipbuilding firms, were in Montreal recently making inspections of properties in the vicinity of the big floating dry dock at Viauville. It is expected that announcement will be made in the near future of the establishment of at least one big shipbuilding enterprise on the St. Lawrence.

Montreal, Que.—Figures for the past year show that the Grand Trunk elevator at Tiffin, Ont., which had a capacity of 2,000,000 bushels, handled, during the 12 months, 13,680,000 bushels of grain, being the largest quantity handled by any elevator on the Great Lakes. The Government elevator at Port Colborne, the capacity of which is 750,000 bushels, made a good second with a record of 12,100,000 bushels handled.

Tenders

Vancouver, B.C.—The contract for 5,000 feet of 6-inch and 8-inch lap weld steel water pipe was divided between Evans, Coleman & Evans, and Robertson, Godson & Co., whose bids were similar.

Toronto, Ont.—The Ontario Pipe Line Co. will be offered contract to supply 5,000,000 cubic feet of natural gas daily to the city. If the company refuses, the city will lay pipes in the new sections.

Waterloo, Ont.—The Kuntz Brewing Co., are receiving bids for construction of a bottling works and boiler house 68 x 190 feet, two stories and basement, of reinforced concrete, structural steel and brick construction.

Regina, Sask.—Tenders addressed to the City Commissioners, will be received until March 15, for the supply of six 500-horse power boilers complete with mechanical stokers and internal superheaters, for 200 pounds pressure.

Hamilton, Ont.—The Hamilton Bridge Co. have been awarded the contract for the steel work on the erection of a boiler shop, blacksmith shop, and locomotive crane shelter in Hamilton, at a cost of \$25,000, for the Steel Co. of Canada.

Moose Jaw, Sask.—Tenders for line supplies will be received up to Wednesday, March 5:—Copper and iron wire, cedar poles, fir cross arms, pole line hardware and miscellaneous line supplies. J. D. Peters is electrical superintendent.

Toronto, Ont.—Bulk tenders for all trades required in connection with the municipal abattoir and rendering building to be erected on Tecumseh St., will be received up to March 4, at the office of Messrs. W. R. Perrin & Co., Ltd., 530 King St. East, Toronto.

Winnipeg, Man.—Tenders are asked by the Winnipeg Public School Board up to March 6, for electrical machinery, equipment and tools required in connection with the Kelvin and St. John's Technical High Schools. J. B. Mitchell, Commissioner of Supplies, School Board Office.

Port Colborne, Ont.—The Allis-Chalmers Co., Milwaukee, have received a contract for furnishing the entire equipment for the second half of the flour mill of the Maple Leaf Milling Co. The Maple Leaf Co. produce 9,000 barrels a day, and are now duplicating their present mill.

Montreal, Que.—The contract for the supply of \$300,000 worth of water pipes in Montreal, Que., was awarded to R. D. Wood & Co. The Canadian Iron Corporation made a protest against the awarding of this contract to R. D. Wood & Co. on the ground that they have no factory in Montreal, but the protest was ignored.

Moose Jaw, Sask.—Tenders for the new 1,500 k.w. Turbo-Generator for the power house have closed, and among others the following were received: The Ridway Dynamo and Engine Co., of Ridway, Pa.; Willans & Robinson, Ltd., Rugby, Eng.; Canadian Westinghouse Co.,; Allis-Chalmers-Bullock. Ltd.; John Birch and Co., Ltd., of London,

BOILERS



“Inglis” is the “Buy” word for Boilers.

“Inglis” spells satisfaction.

Fifty-two (52) years' experience in Boiler making, combined with the most modern kind of a shop means **service**. “Inglis” Boilers never fail to give satisfaction.

Send Us Your Inquiries.

THE JOHN INGLIS COMPANY, Ltd.

Engineers and Boilermakers

14 Strachan Ave.

TORONTO, CAN.

Eng.; Canadian General Electric Co. The Commissioners are considering these tenders.

Vancouver, B.C.—The tender of McLennan, McFeely & Co. (Allen, White & Co.) offering 12,000 feet of two-inch steel cable for use in hauling mains across the First Narrows, was accepted by the city council, at a price of \$8,976. This was the lowest figure. The cable is to stand a breaking strain of 180 tons and consists of six strands of 19 wires. The next tender was that of George Craddock & Co., a British firm for \$9,002. Two other tenders were R. V. Wingham & Co. (Wilkinson Wire Rope Co.) \$9,360, and Ritelie Contracting & Supply Co. (Dominion Wire Rope Co.) \$10,320.

North Battleford, Sask.—Tenders will be received by the Secretary-Treasurer until April 15th, for the following works:—

Contract "A"—Pipe laying and water works and sewers; "B"—Furnishing cast iron and steel water pipes and specials; "E"—Fire hydrants and gate valves; "S"—Furnishing vitrified tile sewer pipe and junctions; "T"—Constructing concrete sidewalks and curbs. Plans and specifications may be seen at the office of the Engineers, To-

ronto and Winnipeg, and at the Town Hall, North Battleford, on and after March 17th, 1913. H. W. Dixon, Secretary-Treasurer, North Battleford; Chipman & Power, consulting engineers, Toronto and Winnipeg.

Swift Current, Sask.—The town council will receive tenders for the supply of the following cast iron or steel pipe:

Cast iron pipe specials approximately 7 tons, or about 100 pieces. Tenders, endorsed "Cast Iron Pipe" or "Steel Pipe" to be lodged with the Secretary-Treasurer not later than noon of Monday, the 17th March, 1913. The council will also receive tenders for the supply of 37-6 in. valves and boxes; 3-8 in. do.; 3-10 in. do.; 3-12 in. do.; 22-6 in. fire hydrants.

Specifications and forms of tender may be had on application to the undersigned. Tenders, endorsed "valves and hydrants," to be lodged same date. George D. Mackie, Town Engineer.

Regina, Sask.—Tenders for the power house equipment, addressed to the City Commissioners, City of Regina, Sask., will be received up to March 15th. This includes:

Six—500 h.p. water tube boilers complete with mechanical stokers and super-

heaters for 200 lbs. working pressure and 125 deg. Fahr. superheat.

Two 133,000 cu. ft. per min., $\frac{3}{4}$ or $\frac{7}{8}$ housing, induced draught fans arranged to discharge through one vertical stack, 12ft. in diameter and 70 ft. high above the base of fans.

The price to be on equipment erected on foundation, built by the City of Regina, to contractors' requirements.

Copies of specifications may be had from E. W. Bull, Supt. of Light and Power, Regina.

Saskatoon, Sask.—Tenders addressed to the city commissioners will be received up to April 15, for one motor pumping engine of 500 gallons capacity, and one motor pumping engine of 1,000 gallons capacity. Tenderers are required to quote on their own specifications. F. E. Harrison, mayor, chairman of commissioners.

Ottawa, Ont.—Tenders will be received at the office of the commissioners of the Transcontinental Railway, Ottawa, Ont., until March 11, for 1732 gross tons of 80 lb. steel rails (A.S.C.E. section) delivered f.o.b. cars at St. Anselme, P.Q., and 4349 gross tons of 80 lb. steel rails (A.S.C.E. section) delivered f.o.b. cars at Hervey Junction, P.Q., on or before 1st June, 1913. Tenders must be made on the forms supplied by

THE

Steel Company of Canada

LIMITED

PRODUCERS OF

PIG IRON

Foundry Basic Malleable

Bar Iron

Bar Steel

Plain Bars and Twisted Squares for reinforcement of Concrete

Bolts and Nuts, Tacks, Screws, Wire Nails, Rivets, Wire

Immediate Shipment all Standard Sizes

Prompt Attention to Orders for Special Sizes

Wrought Pipe, Bale Ties, Lead, R. R. Track Equipment, Field Fencing

DISTRICT SALES OFFICES:

HAMILTON,

TORONTO,

MONTREAL,

WINNIPEG

W. A. MacLennan, Vancouver, B.C.
J. B. H. Rickaby, Victoria, B.C.H. G. Rogers, St. John, N.B.
Geo. D. Hatfield, Halifax, N.S.

The advertiser would like to know where you saw his advertisement—tell him.

THE DOMINION RADIATOR COMPANY, Limited

Messrs. The Sand Mixing Machine Co.,
Brantford, Ont.

Toronto, Sept. 20th, 1912.

Gentlemen:—

Referring to your inquiry of recent date in regard to the Sand Mixing Machine we purchased from you, would say that we have had it in operation now for about two months, and we are very well pleased with it. It is giving us very satisfactory results. There is no question about it being a labor-saver, as well as thoroughly mixing the sand much more satisfactorily than by hand process. We anticipate that we shall place a further order with you for an additional machine just as soon as we have made the alterations to our foundry which are now under consideration.

Yours very truly,

THE DOMINION RADIATOR COMPANY, LIMITED.

P. McMICHAEL, Managing Director.

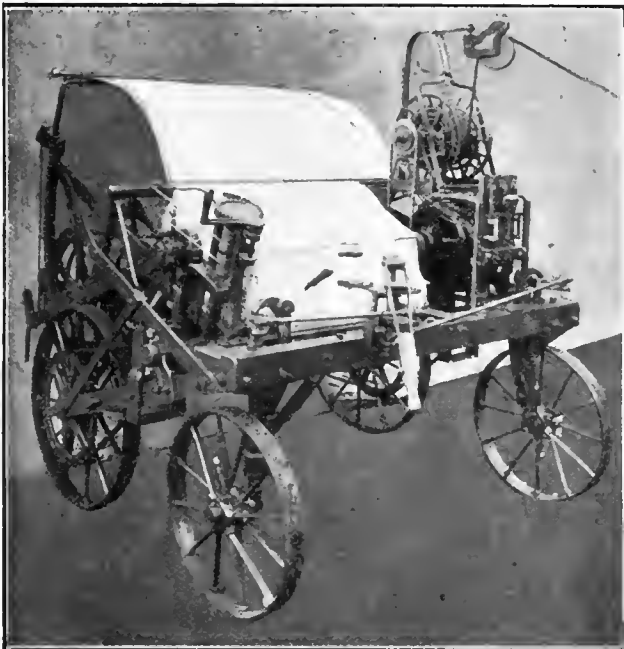

Front View.



Back View.

We can save you a lot of money, and at the same time improve the quality of your castings, decrease your percentage of bad castings, and relieve your foundry foreman of a lot of mental wear and tear by having the sand in first-class shape every morning.

We rent them or sell them outright. Write us for particulars.

THE SAND MIXING MACHINE CO. of CANADA BRANTFORD, ONT.

N. D. Neill, Gen. Mgr.

This Trade Mark



safeguards the interest of thousands of file users everywhere.

Is the only Line of Files from 3 to 24 inches that are made absolutely of

CRUCIBLE STEEL"

Delta Files are the all-round leaders.

They cut clean and fast and leave a smooth finish—the quality and temper ensure durability and economy.

There is a shape and size to meet the requirement of every file user.

Give them a trial—they speak for themselves.

This cut illustrates our Half Round Bastard File, the staple file for the machinist, having one flat side and one half round side which shape fills most requirements in filing. It tapers from 1½ in. beginning at 2-3 of the length to ⅝ in. at the point on a 14 in. the most useful length for bearings from 1¼ in. up and any concave surfaces.

Look for the "Delta" trade mark, when placing your next order—its a guarantee of satisfaction.

If your jobber does not sell them, write us direct.



DELTA FILE WORKS
PHILADELPHIA, PA.

CANADIAN AGENTS:
H. S. Howland, Sons & Co., Toronto;
Stark, Seybold, Montreal; Wm. Stairs,
Son & Morrow, Halifax; Merrick-Anderson Co., Winnipeg.

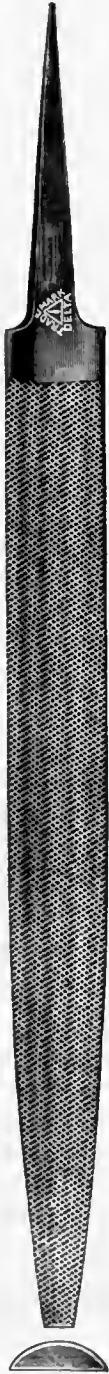

the commissioners, which may be had on application to Mr. Gordon Grant, Chief Engineer, Ottawa, Ont. P. E. Ryan, Secretary, the commissioner of the trans-continental railway.

Personal

W. E. Skead has been appointed electrician for the city of Brandon, Man.

E. J. Phillip, Berlin, Ont., has accepted the position of manager of the light and power department at Brockville, Ont.

F. L. Hubbard, son of Ald. W. P. Hubbard of Toronto, has been appointed assistant to the General Manager of the Toronto Railway Company.

W. K. Jeffrey, who has been acting manager of the Ottawa Car Company since the death of Mr. James Buchan, has been appointed manager.

R. J. Miller, Montreal, has severed his connection with the Canadian General Electric Co., having accepted the position of sales manager with the Engineering and Equipment Co., Montreal.

Alvin Schlarbaum, B.A.Sc., of the staff of Smith, Kerry and Chace, has accepted the position of hydro-electric engineer with the Riordon Pulp and Paper Co., of Hawkesbury and Merritton, Ont.

James Pemberton, chairman of the benefit fund of the Steel Co. of Canada, received a presentation by his fellow employees, on Saturday, Feb. 15, at Hamilton, on the occasion of his retirement from the chairmanship.

Marcil Peuegat, honor graduate of '08 and instructor of drawing of the School of Practical Science, Toronto, has been appointed city engineer of Berlin, Ont. Forty applications were received for the position.

Dr. A. C. McKay, principal of Toronto Technical School, has refused an offer from the United States at a salary of \$10,000 per year. An offer from the University of Manitoba to go there at \$8,000 was also refused. His salary in Toronto is \$5,000.

A. H. Chave, general purchasing agent of the Canadian Car Foundry Co., has been appointed general assistant to the executive of that company. Mr. Chave is a director of the Platt & Latchworth Malleable Iron Co., and the Canadian Steel Foundries, Ltd.

Alfred Still has resigned his position as chief electrical engineer to the mines department of the Algoma Steel Corporation of Sault Ste. Marie, Ont., to

take charge of the course in electrical design at the school of Electrical Engineering, Purdue University, LaFayette Indiana.

James W. Carr & Co., 35 Queen Victoria Street, London, E.C., Eng., use only the finest Sheffield crucible cast steel in the manufacture of their cutting tools, and from the fame of their product, they consider this line is apropos: 'When you think of 'Cutters' think of 'Carr.' This firm has favored us with a copy of their new catalogue of milling cutters, reamers, gauges, etc., which will be sent to users free, on application.

A. E. Munn, for the past eight years manager of the Canada Wood Specialty Co., Orillia, Ont., who left last week for Vancouver, B.C., was presented with a handsome solid silver tea service at a banquet tendered by the citizens. The factory employees on Friday last presented him with a cabinet of silver. Mr. Munn's successor as manager of the Canada Wood Specialty Co. is Mr. A. H. Waite, who has been connected with the firm for several years.

Obituary

Sir William Arrol, the most noted of British bridge builders, died, on Thursday, Feb. 20. He constructed the present Tay and Forth bridges, and was born in Ayrshire, Scotland, in 1839.

Alfred Hawksworth—The death occurred a few days ago, at his residence, 250 Metcalfe Avenue, Westmount, of Mr. Alfred Hawksworth, president and manager of Alfred Hawksworth & Son', Ltd., dealers in mill supplies, 461-463 St. James Street. Mr. Hawksworth had been in indifferent health for over a year. Mr. Hawksworth was born on October 9, 1846, at Glossop, Derbyshire, England, and as a young man went to the United States, settling at Lonsdale, Rhode Island. Later he moved to Concord, Mass., where he was appointed overseer of Daymn & Smith's cotton mill; afterwards taking charge of the largest cotton mill at Manville, R.I., where he invented a velvet and plush loom. His business career included the charge of cotton mills at New Bedford and Newburyport, Mass., and Pawtucket, Providence and Pontiac, R.I.; in the latter place he was for eight years superintendent of B. B. & R. Knight's cotton mills, and almost lost his life, being blown twenty feet away by the explosion of a valve on one of the boilers. He left Pontiac for Montreal to act as manager of the Merchants Cotton Mills, at St. Henri, now a part of the Dominion Textile Company, Ltd. Some years ago he resigned and started the mill supply

house of Alfred Hawksworth & Sons Company, Ltd., which was incorporated in 1905.

Trade Gossip

St. Thomas, Ont.—An acetylene plant is being installed at the Erie Iron Works for the oxy-acetylene welding process.

Welland, Ont.—The Electrical Power Co., of Fort Erie, intend running a low tension wire between Ridgeway and Fort Erie in the near future.

London, Ont.—The Council have decided to bridge the Thames at the Wharmliffe Road. The necessary additional \$5,000 debentures will be issued and the bridge constructed, joining West London to South London.

Ottawa, Ont.—The Quebec Rapid Transit Railway Co. are seeking powers to run a tramway from Quebec to the Isle of Orleans, and will construct a bridge from the north shore of the St. Lawrence to the island. A couple of branch lines are provided.

E. M. G. Cape, general contractor, Montreal, has received the contract for the new reinforced concrete office and warehouse building which the Canadian Fairbanks-Morse Co., Ltd., are about to erect on St. Antoine Street, Montreal. This will be a fireproof structure of seven storeys. T. Pringle & Son, Ltd., are the engineers and architects.

Webster & Sons, Ltd., 31 Wellington Street, Montreal, an off-shoot of the firm of Hyde & Webster, have acquired the old-established business of F. Hyde & Co., Montreal, and propose to continue same in all its branches. They have taken over the entire stock, office and selling organization of F. Hyde & Co.

Escher Wyss & Co., Montreal, have been awarded the contract for the manufacture and installation of three Water Wheels and Governors of 6,800 H.P. each, for the extension of City of Winnipeg Power Station at Point Du Bois. Although Escher Wyss & Co.'s price was the highest of all competitors, their tender was the most advantageous for the City as they guaranteed by far the highest power when using existing foundations and draught tubes.

Catalogues

The Beardmore Belting Co., Ltd., Toronto.—Manufacturers of oak tanned leather belting, are giving away neat memo books, bound in leather, as souvenirs.

WOOD METAL
PATTERNS
"GUELPH"
PATTERN WORKS
135 Woolwich St., Guelph, Ont

JOHN CARR
PATTERNS MODELS
IN
WOOD OR METAL
MECHANICAL
DRAUGHTSMAN
Special Machinery
Designed
18 MARY ST. HAMILTON ONT

MAPLE LEAF
STITCHED COTTON DUCK
BELTING
DOMINION BELTING CO. LTD.
HAMILTON CANADA

PATTERNS
IN WOOD
~ ALL KINDS ~
Difficult Core Work a Specialty
High Grade · Right Prices · Prompt Delivery
SATISFACTORY WORK GUARANTEED
THE HAMILTON PATTERN WORKS
258 CATHERINE STREET NORTH
HAMILTON, ONT.

PATTERNS
FOR
ALL KINDS OF MACHINE
WORK MADE IN
WOOD, BRASS
WHITE METAL OR IRON
by the very highest class of skilled
mechanics.
Only the highest grade of material
used in our work. We can handle
your pattern work to your complete
satisfaction.
Let us quote prices.
TORONTO PATTERN WORKS
87 Jarvis St. Toronto, Canada.

**Oil Tempered
Steel
Springs**
—for every purpose
and the best for each
use.
Special styles of
all kinds to order.
**THE CLEVELAND
WIRE SPRING CO.**
Cleveland, Ohio.



THE JOHN MORROW SCREW, LIMITED

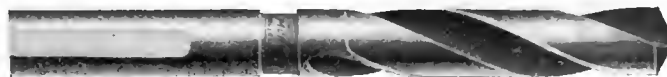

Best Drills

Best Set Screws

Take no chances, but buy only "MORROW" make. All Jobbers can supply you, or direct from the makers.

INGERSOLL, ONTARIO

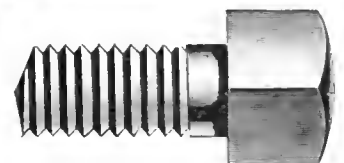

Classified Advertisements

MACHINERY FOR SALE

MACHINERY FOR SALE—NEW AND SECOND-HAND MACHINERY, engines, boilers, wood and iron working machinery and supplies. Write, stating what you require. Prompt and careful attention to all inquiries. The Advance Machine Works Co., Montreal, Que.

FOR SALE—TWO 27 IN. VICTOR TURBINES, 400 H.P., under 30 ft. head. In excellent condition. Cheap. Address Box 202, Massena, N.Y.

FOR SALE — ONE KEIGHLEY GAS ENGINE, 45 H.P., in first-class shape. Reason for selling, equipping new plant with electric power. This engine can be seen running at any time at present works. The Thomson Monument Co., 1194 Yonge St., Toronto.

BELTING, PACKING, ETC.

BELTING FOR SALE — 800,000 FEET OF best quality leather, rubber, hair and canvas belting, bought from bankrupt manufacturers at 25 to 75 per cent. less than the regular value. Also a large quantity of slightly used belting, piping, chains, rolls, pulleys, hangers, cotton waste, etc., at very low prices. Send for catalogue, Imperial Belting & Supply Co., 5 Queen Street, Montreal.

BELTING, RUBBER, CANVAS AND LEATHER, hose packing, blacksmith's and mill supplies at lowest price. N. Smlth, 138 York Street, Toronto. (2tf)

MANUFACTURING CENTRES

FREE FACTORY SITES — SEVEN RAILROADS, deep water, Niagara power, natural gas, low taxation, abundant labor. Welland, Ontario. B. J. McCormick. (12y)

WE ARE IN A POSITION TO FURNISH castings, light and heavy, preferably heavy. We can make prompt deliveries, inquiries solicited, Pollard Manufacturing Co., Ltd., Niagara Falls, Ontario. (3)

MR. EMPLOYER WHO WANTS A STENOGRAPHER. The Remington Employment Department will save you the waste of time involved in interviewing a number of applicants. Tell us your requirements and we will immediately send you a stenographer competent to satisfy your needs. We make no charge for our services. 144 Bay St., Toronto.

ARMSTRONG BROS.

83 Richmond St. West, Toronto

Mfrs. of SPECIAL MACHINERY

Patents Perfected

GEAR CUTTING, TOOLS, DIES, ETC.

Ruching and Pleating Machinery.

PATTERNS

WOOD AND METAL

Allow us to estimate. Satisfactory work guaranteed.

TAYLOR PATTERN WORKS WALKERVILLE, ONT.

Keep in mind the dominant fact that mankind from its first appearance on the earth has been schooled by nature to look for signs; for invitations to taste; for suggestions as to what to wear. Tell your story briefly, forcibly, truthfully, and address it through the proper media and you can successfully apply advertising as a means to increased distribution.

Thos. Firth & Sons, Ltd., Sheffield, England, have sent us an interesting booklet describing their large steel works, in which are made the many well-known brands of tool steel produced by this firm. J. A. Sherwood, 507 St. Paul Street, Montreal, is their Canadian agent.

The Foster Engineering Co., Newark, N.J., describe in their catalogue No. 20, the Foster pressure regulators, automatic relief valves, free exhaust valves and other high-grade valve specialties. The catalogue is well printed and contains numbers of clear illustrations.

Cling-Surface Treatment for Ropes is the title of a bulletin just published by the Cling-Surface Company, Buffalo, N.Y. This bulletin shows a number of noteworthy treated rope drives, gives technical data, and carefully describes them all. A copy will be mailed on request.

The Goldschmidt Thermit Co., Richmond Street, Toronto, have issued a calendar, illustrating their Thermit system of welding. The results are shown by a series of splendid photographs, in which some striking examples are given, where such a system saves much time and many dollars.

Starrett Vernier Calipers are explained in a neat folder issued by the makers. They are graduated in either or both English and metric divisions for outside and inside measure, and are warranted accurate. The jaws are carefully hardened and accurately ground. Considerable space in the folder is taken up to show how the Vernier is read.

The Elk Fire Brick Co., St. Mary's, Pa., have incorporated a subsidiary concern known as the Elk Lake Fire Brick Co., of Canada, with offices at 19 Federal Life Bldg., Hamilton, Ont. The firm have done this to render better service to their customers in the Dominion. C. W. Clewell, vice-president of the company will manage the Canadian end.

The Allen Manufacturing Company, Hartford, Conn., U.S.A., inform the world at large, that 1,500 people are killed or maimed for life every year in the United States, by projecting set screws. This booklet contains pictures of workmen being hurled through space, their clothes having caught on a set screw. They certainly set the manufacturer thinking. Further on in this booklet, considerable space is occupied in telling how the set screw menace can be overcome.

Chalmers and Williams, Chicago Heights, U.S.A., handle the Torpedo Conveyor, something new in conveying

machinery. It consists of a sheet steel trough in sections, supported on carriages, which run backward and forward by means of wheels and a short track. On the forward motion air is compressed in a cylinder under the conveyor by a piston running into it. On the return motion, the compressed air, through the piston, gives to the trough a quick reverse, which draws the trough backward, leaving the material at a point to which it has been conveyed on the forward motion. The success of this conveyor has been achieved through its simplicity in construction and very small cost of upkeep. The mechanism is described in a small leaflet issued by the firm.

The New Haven Sand Blast Company, New Haven, Conn., U.S.A. It has remained for this firm to place before the foundry trade a self-contained sand-blast rolling barrel, where the cleaning material does not leave the barrel, but is retained, and used over and over again. This means that no expensive sand hose is required, no extra room for sand mixer, and labor expense is considerably reduced. There are four nozzles in one barrel, and the firm claims that for cleaning small, medium sized castings and forgings, their machine is the most efficient, economical one ever placed on the market; the complete weight is approximately 5,600 lbs. Tests made by Professor William F. Magruder, of the Ohio State University, Columbus, Ohio, published by the American Society of Mechanical Engineers, show that:— "With a constant pressure of 60 lbs. in the machine, and a fixed distance of 8 inches from the sand nozzle to the test bar, the largest amount of metal was removed, and the least amount of sand was required to do it, when the angle between the nozzle and the surface of the work was from 40 to 60 deg.

New Incorporations

Anderson Co., Ltd., Toronto, Ont.; capital, \$40,000; to manufacture motor cars, engines, etc.; provisional directors, George Anderson, Frank G. Anderson and James A. McHardy.

The National Brass Co., Ltd., London, Ont.; capital, \$40,000, to manufacture brass goods and plumbers' supplies; provisional directors, John F. Grant, Charles H. Ivey and others.

Montreal, Ont.—On the board of the new Ice Manufacturing Company are the following:—Mr. W. T. Rodden, the president, a director of the Montreal Abattoirs, Limited; Mr. F. W. Molson, vice-president; Lieut.-Col. E. W. Wilson; Lieut.-Col. Labelle, one of the new Harbor Commissioners, Mr. H. F. Cook, and Lieut.-Col. Carson.

The New Era in Machine Tool Design—Its Requirements*

By E. P. Bullard, Jr.**

The very fact that the author of this paper occupies a place of prominence in the machine tool industry is sufficient of itself to commend a careful perusal by our readers of what he has to say, and need we point out, therefore, the thoroughly practical and easily comprehended language in which the subject is treated. A study of the various points raised will amply repay the time spent.

WE have been given a new word during recent years and a new profession has been created. We are told that our shops are inefficient; that our methods are out of date; and that we have a great many false motions. Our railroads have been informed that they lose a million dollars a day by inefficient operation, and it is stated that a railroad car is in use but two hours out of the twenty-four. This new knowledge is the result of careful analysis, and the exact knowledge so obtained, forms the foundation for the new era. What do all these things mean? They mean that there is great demand being placed on the mechanical world at large. All of our industries are being called upon to produce better goods at a lower price and to increase production. We must be more efficient in our work, as engineers and as shop managers, if we are to succeed. We cannot hope to be paid for inefficiency. The world is going on; it is not standing still; and those of us who are going to uphold the names of our concerns and our individual reputations before the mechanical world, can do it only by keeping pace with the times.

The Application to Machine Tools.

You ask, what has this to do with machine tools? Stop and think. Can you imagine a device or a mechanism of any description, which is not affected by the efficiency of machine tools? Everything we have, such as safety razors and the capsules in which we take our medicine, are the product, indirectly, of machine tools. We have come to an age of exact knowledge. We no longer do things in a haphazard way. We have means for measuring accurately and of determining the strength and hardness of materials. A bolt made in the East will fit a nut made in the West. We have come to a state of exact knowledge and must use that in the design of our product, so that we may benefit by the experience of others, and may have our manufactures compare and compete with those produced anywhere. We know the strains and stresses of materials, and we no longer purchase the latter by guesswork. We do not place an order for so much steel and al-

low the steel mill to send us any kind of steel it has in stock. We specify the percentage of carbon and the chemical analyses of the steel and we expect it to give certain physical results; so many thousand pounds tensile strength, a stated elastic limit, a certain percentage of elongation, etc.

Standardization—Time Study.

We have come to the age where we can specify definitely what we want and get it. Standardization has become the watchword. We can specify a certain number of thousandths gauge and get it. A gauge made in one section of the country will fit or check with a similar gauge made in another part of the country. We standardize our operations. We make time studies of operations and benefit thereby, having got beyond the age when it is argued that a time study is of no benefit. We know that we can definitely calculate the time of machining a certain piece. I remember the first automobile fly wheel that we produced. Our estimators figured that we could machine one of these fly wheels in 19 minutes. The work came into the shop, and the shop superintendent came to me and said:—"That is a joke." "What is a joke." I asked. He replied, "That nineteen minutes, for it will take nearer forty-five minutes." However, we found that by following out the time study we obtained our planned result. We have a letter in our files to-day, from the concern that purchased the machine, which says that they have averaged 17 minutes per piece on 14,000 fly wheels. I give you this as an illustration of the value of a time study. Without planning the sequence of operations and following these, we could not have accomplished it. As it was, we averaged seventeen minutes each on 14,000 wheels, showing that many of those wheels must have been made in considerably less time.

We have our instruments of precision. Have any of you ever stopped to think what marvelous things those are? Marvelous in their exactitude—instruments with which we measure almost anything you can think of, from the hardness of material to the exact size of a particular piece. I sometimes marvel because I know the difficulty of maintaining these standards.

We have a demand, a tremendous de-

mand, an exacting demand, a demand from the masses, for better conditions of living, and of travel. They want heat, light, comfort, all the thousands of luxuries which this age has given us, and which now become necessities. Now, how is this demand to be met? We think of it as extravagance, but is it? It is simply the masses living up to the age. There was extravagance in earlier periods than ours. Louis XVI, it is said, spread gold dust on his royal signature, instead of blotting it. We have other ways of being extravagant. We want automobiles, we want telephones, we want the thousands of things to-day which were luxuries previously, although now considered absolute necessities. The luxuries of to-day are the necessities of to-morrow.

The Call for Machine Tools.

The machine tool must meet this demand, for the burden of it bears directly on these, the prime factors in the development of civilization. A fanciful thought I will admit. If we are to meet this demand, we cannot do it by walking in the footsteps of our fathers. They bought iron and bought steel. They did not specify what their iron was to be, nor did they specify the analysis of the steel. They used other materials, such as bronze, which was yellow, and as long as it was yellow it was good for a bearing. We cannot walk in their footsteps and win. We must utilize the knowledge which is invaluable. We must use the instruments of science and we must profit by the experience of other industries. Other industries have advanced amazingly. Take the automobile as an illustration. It was introduced but a few years ago and was a crude machine, because materials were not suitable for the service required of it. The demand arose for better materials, more suitable materials, and these have been supplied, until to-day a study of the materials that enter into a good automobile is a wonderful study, a comprehensive study. The manager of one of our automobile concerns told me there were fifty-three distinct varieties of steel in his machine, each one selected as best for a certain service.

Granting then that the machine tool is a prime factor in the advancement of our civilization, it seems right and proper that machine tool builders should exercise their energy to make

*From a paper read before the Cleveland, Ohio, Engineering Society.

**President of the Bullard Machine Tool Co., Bridgeport, Conn., and President of the National Machine Tool Builders' Association.

their machines more productive, more useful, if they are to be a real help in the upbuilding of other industries.

The Ideal to be Compassed.

How may this object be attained? The answer lies in the one word "Analysis," analysis of the work to be done, the conditions to be met, and an analysis of the means already at hand. For example, what is indicated by an analysis of present day shaft-turning conditions?

First.—The material to be worked is tough and hard, requiring more power to obtain a given result.

Second.—Tool steels are wonderfully improved, enabling us to plan a greater result in a given time—still more power required. Greater power must then be transmitted, to attain which we must increase, throughout, the proportions and strength of the machine parts involved. How to satisfactorily accomplish this result can only be learned through analysis.

Have designers followed this method? What difference is there between many lathes of to-day, for instance, and the lathes of ten years ago? That is the point, and let me say here, there is not the difference between the machine tools of to-day and the machine tools of ten years ago that there should be. They have not, in all cases, kept up with the times. Many machine tools are, to-day, identical in detail with the construction of ten years ago, but I hold that anyone who continues to build a machine of that kind cannot hope, because of its inefficiency, to keep his trade. The machine tool of to-day must meet the conditions of to-day.

The Element of Control.

In analyzing the various elements of machine tools, the question naturally arises, wherein can they be improved? There are many ways. First, let us consider the question of control. Control is the essence of machine tool operation. It plays the largest part in the production of work. Control is everything. We see it in other products and never think anything about it. When you touch a typewriter key and the letter is impressed on the paper, we think little of that; but there is infinite exactitude in getting that impression. So is it with the machine tool. It must not merely be started and stopped; it should be stopped exactly as you want it, and stay stopped until it is again started. The machine tool should do the work, and the operator should use his energy solely in directing it. He should not be called upon to spend his valuable time nor his mental energy in operating an oil can on sixty or a hundred different holes which are supposed to be oiled, neither should he be called

upon to shift dangerous belts or move heavy parts. He can do all of those things by power, and there is absolutely no occasion to-day for an operator to do them. Any machine which compels the operator to use his physical energy to move heavy parts, to shift belts, or do any of those things which waste time and productive energy, is inefficient in design and construction.

The Element of Durability.

Is it unreasonable to suppose that, having paid coin of the realm for a machine, we are entitled to durability? Should not a machine stand up and do its work—with inefficient men, maybe? If it is not a durable machine its ability to produce ceases, therefore, it is reasonable to ask that a machine be durable, that it will remove the amount of material required in a given time and do it easily and comfortably, and have a sufficient factor of safety in the design of its parts to provide for a continuous performance of the work for which it was installed.

The Element of Adaptability.

By adaptability I mean the ability of the machine to meet conditions. Let us assume that we have purchased a machine for a given purpose. The machine should meet our conditions, being of little interest to us that it may be able to produce work for somebody else—that it may meet Jones' conditions.

The Element of Productibility.

There are several factors which enter into the question of productibility, each of which is, in a way, related to the others. If, for any reason, the machine is not in service it is not producing and is, therefore, inefficient. Continuous operation is an essential factor which is dependent not only on durability but on adaptability as well. If minor details of construction are constantly giving trouble, it is not a durable machine, and if long delays are frequently occasioned by the necessity of changing or providing complicated and expensive tool equipments, the machine is not adaptable, and the expenditure, therefore, has not been wisely made.

Starting and Stopping.

I have already spoken of the starting and stopping, and wish to emphasize the importance of that detail. I believe the starting and stopping of a machine is, possibly, the most important function of the operating mechanism. The machine should start just when the operator wants it to. It should not start a little ahead of time and take his hands off or his arms off, and it should not lag in starting. It ought to stop just as exactly as you stop an automobile, a trolley car, or any other moving object. The starting and stopping of a

machine are two very important factors in its operation. Shifting belts do not meet the new conditions; they are too slow. Efficient clutches are difficult to make; in fact, I think the weak point in about 90 per cent. of the automobiles in service is in the clutch. The clutch does not work; it starts too quickly, or it drags. A clutch in a machine tool is highly important, and cannot be too good, while the brake merits equal consideration.

Power Operation of Heavy Parts.

Did you ever stop to think what it means to take hold of a large planer or lathe and move the heads or carriage any distance? It is a tremendous piece of work. A man who is not in training cannot do it, and a man who does it frequently during the day is spending a large part of his energy in useless work, wasting his physical as well as his mental abilities, because power can be supplied to the operation of those parts just as easily as to driving the tool. Power operation of heavy parts, is here to stay. It may be inefficient on some machines, it may be inefficient on all, but the time will come when you cannot hire a man to run a machine in your shop unless the machine is equipped with mechanical means for operating the heavy parts. I refer to machines having heavy parts, of course. I do not expect to see the little light parts power controlled, but the time will come, just as sure as can be, when men will refuse to run machines not so equipped. It is essential then that we produce machines that are so equipped. Incidentally, it is just as essential that we should perfect the operation and motion of those parts so that they are under as absolute control as the control of starting and stopping, which I have already stated is very important.

Setting of Tools.

In the matter of the setting of tools, I have gone around the country with a stop watch in my pocket, so that the operators could not see it, and have made time studies on my own account, recording the time which the average operator requires for the setting of tools. My calculations may not agree with your ideas on that subject, but I am convinced, and I think it can be demonstrated, that about one-third of the total time paid for is spent in securing sizes. For instance, a man takes a steel casting, and he does not want to spoil it. He has got to reduce it to an exact size. He puts it on the machine and spends about fifteen minutes cutting it down a little. After that he tries the calipers on the turned surface and finds that it is about one-eighth of an inch too large. I notice it is usually about one-eighth of an inch. He then starts in and repeats that operation sev-

eral times. One man out of a thousand can set a machine accurately enough to do this work without wasting time, but the other nine hundred and ninety-nine will do just as the man did in the ease referred to. You can see it everywhere; consequently, your machine tool should, to be efficient, take that burden off the man and give him means of obtaining sizes quickly and accurately, and of duplicating sizes every time, so that the mental strain, due to his feeling of responsibility for the casting, is taken off his mind, and he feels free to set the tool in the shortest time and in the most effective manner.

Power.

Under productibility comes the question of power. How often do you see a machine that can be loaded right up to the limit that the tool steel will stand, and take cuts easily and comfortably and look as if it was going to continue to take them as long as necessary to machine the piece? I suppose there are fifty compounds on the market for making belts pull, but let me tell you that a truly efficient machine tool does not need them, for the power will be there in the form of a big belt, a wide belt, and there will be plenty of strength of materials between that belt and the cut to take all that the belt will pull, and that belt will pull more than the cutting steel will stand. We know that such is possible because we do it.

I have seen a comparatively small machine turn off 1,785 lbs. of cast iron chips in an hour. The casting was large and the cuts deep, heavy and fast, in fact unnecessarily so, but the machine came through that durability test without difficulty and proved that the design was right. Power in abundance, excess of power, is an essential part of a producing machine and it is in this respect that the average machine in the shop is often lacking.

Correct Distribution of Metal.

Probably, every man, when he buys a machine tool first, asks the question, how much does it weigh? Now stop a minute. What does that question amount to? If I, as a machine tool builder, wish to deceive you, I can pour pig iron into the base of my machine and give you weight that costs little and is valueless to you. We can take little, lightly designed machines and fill them up in the bottom and give you weight, but you would not have productibility, because the weight would be in the wrong place.

You will find in the text books, which have been prepared during the past ten years, statements to the effect that machine steel may be turned at the rate of 25 ft. per min., and cast iron at 30 ft. Now let me tell you something:—I

have seen a piece of machinery steel, 40 carbon open hearth steel, turned at 425 ft. a minute, just like a piece of wood, and turned easily and freely. This was accomplished because the machine could do it easily; it did not vibrate and the cutting tool had an opportunity to work. The cutting tool is a delicate thing, and must have a keen edge to work properly. If it has a dull edge—which it gets very soon after vibration sets in—it ceases to be a cutting tool and becomes a pushing tool, and these ragged, torn pieces you see around a shop represent inefficiency, lost power, poor tools and poor machines.

The correct distribution of metal is an essential point. I have seen a bor-

AS OTHERS SEE US.

Congratulations to our esteemed contemporary, "Canadian Machinery," on becoming a "weekly!" We read in the columns of that journal that as regards the machine tool industry, trade conditions during the past year have been very encouraging, and a steady growth in the industrial development of the country is indicated. Manufacturers, too, are beginning to realise that the increased competition which accompanies this growth calls for more up-to-date methods, and there is an increasing demand for modern rapid production tools and equipment. English and European manufacturers are also beginning to realise more than ever the profitable field which awaits their enterprise in Canada, and to throw aside in some degree the conservatism that has hitherto marked their attitude to the developments in manufacturing conditions, which demand radical changes in machine tool design, and are beginning to realise, that if they would compete successfully in the Canadian market, they must adapt their product to the standards and conditions of a new country.—Page's Weekly.

ing machine take a cut 1 1/8 inches wide, 1-32 inch deep, at 150 ft. per minute cutting speed and produce a smooth cut. That was a finishing cut on a cylinder and it was satisfactory. Only the correct distribution of metal can give that result, and that tool could not be made to stand up if the metal in the machine were not there to properly support it and hold its cutting edge right to the work. The correct distribution of metal is one of the very important factors in

machine tool design. Further, I believe that machine tools as a rule are light in some of their very essential parts. I speak of the general run of machines which I and others produce, and believe that when we come to have a full understanding of where we should place metal and how we should place it and what kind of metal it should be, we will make a great advance.

Cutting Lubricants.

There is another point we can make in the cutting of metals, which has to do with the production of work, and which seems to me to have infinite possibilities; that is, the use of cutting lubricants I had it brought very forcibly to my attention some time ago that there was a large saving to be made in power by the use of cutting lubricants. A machine was in operation in our plant on a steel casting. The foundry, for some reason best known to themselves, had left about three-quarters of an inch excess on the diameter of the casting, the length of which was about sixteen inches.

The machine was running along very nicely with two large streams of water—I think they figured on about thirty-six quarts a minute, thrown directly on the cuts. There were two cuts, one on the top and one on the side. The chips were turning blue when they came out of the water. After watching the performance for some time, I said to the operator, "Fred, if we turn that water off, what will happen?" He said, "It will burn the tools" "Well, let's shut it off and see," I replied. So we shut down the water and the machine made one-half of one revolution before the belt went off. We thought we had a broken tool, or that a tool had burned; we backed the machine out and found the tools were O.K., they had not run long enough to be destroyed. On starting up again, with the water, everything went along easily and comfortably. Once more we cut the water off, the machine going less than half a revolution this time when the belt flew off.

I adopted this procedure enough times to convince me that there was something there I did not understand, for I had always believed that the lubricant simply made tools last longer, and did not know that there was any appreciable difference in power consumption. We attached a motor and recording Watt meter to the machine and did some experimenting. After several days—which represented all the time available—we satisfied ourselves that on this heavy cutting there was a difference of 43 per cent. in the power required, using cutting lubricant and where it was withdrawn. For lighter cuts we found, of course, less difference, yet there was 43 per cent. on that particular piece; a con-

siderable item, because we have to pay coal bills and also for tools we burn up. Under these conditions, it does not pay us to generate too much heat or to keep on generating any, unless means are provided to absorb it in a cutting lubricant.

Further experiments along that same line showed that pieces treated without lubricant became so heated that it was not only difficult to handle them, but the dimensions were all out. A hole 15 inches in diameter, when the piece was cold, became 15 inches plus .009 when a slight racing cut was taken across the top of the casting. Had we taken measurements of the piece when hot, they would have been incorrect and we would have had to make an allowance for that heat, an altogether unknown quantity, depending entirely upon the shape of the piece and the amount of heat generated. I believe that not only will we turn all steel with cutting lubricant in the future, but I believe that we will turn cast iron with cutting lubricant. The latter is not such a foolish thing as you might think. We had some large castings which had to be accurate and which got very warm in roughing out; consequently, the error was an unknown quantity. By using cutting lubricant we kept the piece cool and eliminated the possibility of error. Cutting lubricant is a thing we have to deal with, as it represents a wise investment.

Alloy Steels.

What are we going to do to make our machines stand up? As we go around our shops we find a machine "down" here and there. We cannot do it by using carbon steels. Automobiles could not run to-day, if they depended upon the steel which went into automobiles ten years ago. We must use alloy steel. We have come to a point where the alloys introduced into steel give qualities previously undreamt of. You can take a piece of chrome-nickel alloy-steel and you can form a gear blank of it, and after heat treatment you can hammer one of the teeth over against one of its fellows without breakage. You cannot do that with a piece of cast iron. Physical tests of alloy steel show 240,000 to 245,000 lbs. of elastic limit, and 260,000 to 270,000 lbs. tensile strength.

From this grade of steel we can produce a class of goods guaranteed to give certain fixed results. Such steel is not expensive. You cannot measure the value by the pound. Its value is unknown. You can get wonderful results from the use of this material, and when we use this material throughout machine work, gentlemen, you will be as independent as the Oil Trust. Another material available to-day, not have ten years ago.

We can get castings made of steel that run almost as good as gray iron castings, but infinitely stronger, and we can buy them on a chemical and physical analysis basis.

Forced Lubrication.

About a year ago I was in a machinery dealer's store looking at a very handsome machine. It was beautifully painted and polished. Every detail had been taken care of. I noticed a little round disc about as large as a 25 cent piece which said "oil here." I examined the machine and found 114 of such discs. There were 114 holes on that machine which required attention. A man had to go around every morning with a squirt can and oil each hole, and there are one hundred and fourteen chances to one that he would miss one, and, that possibly, the most important one on the whole machine. This set me thinking. I used to have an old automobile which I had to go over about every 20 miles with a squirt can of oil, and it made no difference how much I put in the rear axle, it would not stay there anyway. Those were the instructions on that car. I had a later car in which oil was pumped into the bearings, etc., and this struck me as being about the perfection of lubrication. To-day, I am convinced that forced and not squirt-can lubrication, is one of the elements in machine design which we have got to consider. I believe that in five years from now, all machine tools will be so lubricated, for it is obvious we cannot get away from it. No amount of criticism will prevent its being done, and the objection raised, that the oil will get dirty, has no foundation. I think it is a fair assertion to make, that with properly proportioned bearings, so lubricated that the two metals cannot come in contact with each other, the film of oil being maintained by a fresh supply, the life of the machine is prolonged indefinitely.

Limited Belt Speeds.

There are limits to everything. Belts are efficient up to a certain point, and when you run them above that, they cease to be efficient and larger belts are required. Some may argue that they do not believe in belts, that they want the machines motor driven. Very well, reasonable speed still holds good. We all prefer moderate speed motors. We do not want our gears running like buzz saws. Gears can run comfortably and easily and still do their work. This applies just as properly to a machine tool as to an automobile.

Another word about excess belt power. I referred to that before. You do not want to be right up to your limit in everything. If you erect a building you want to have a factor of safety in that building. Should you not

then have that same reasonable factor in your belts? A factor which will give your belts longer life and give you larger results. Your belt need not be so tight if it is large enough, and your bearings also will be all the better for the excess belt power.

Limited Gear Speeds.

A further word about the limited gear speeds. I was in an office recently where they had some 28 noiseless typewriters. I do not know anything about the typewriter itself or its efficiency, but it certainly was very nice to have the office so quiet. There was not that continual click, so familiar and yet so annoying. Gears running about 600 ft. peripheral feet a minute will be quiet. Text books tell us that gears can be operated up to 1200 ft. per minute, and automobile men run them up to 2000 ft. at times, but they have to run on low gear and on the maximum engine speed.

Adaptability.

To secure adaptability to your work, the tool equipment must be universal, and should be a standard tool equipment purchased from the maker of the machine. If the total time for doing a piece is an hour, and a man has to spend half an hour setting it up, there is inefficiency. Machines which, when you turn a lever, go ahead as you direct, save this setting-up time.

How shall we save time between cuts? What is the use of cuts at high speed, ripping things to pieces and then losing all we gain because we cannot cut the time between cuts. To cut your costs properly, you must cut the time between cuts. Losing time between cuts is exactly like that idle freight car which they say is in use but two hours out of twenty-four. You can save by using a machine which is so controlled that the changes of speed and changes of feed and everything required to put the machine into operation can be performed in the shortest possible time.



PREPARING PARTS TO BE GROUND

TO obtain the highest degree of economy with grinding machines, it is important that all processes of finishing should be considered. Some years ago, the practice of allowing from .005 in. to .008 in. to grind off was considered proper, and the machines then obtainable really saved time in finishing. With the present type of grinding machines, less care is necessary in preparing the pieces to be ground, and, as would naturally follow, greater economy is attained.

Assuming that the piece to be treated is in the rough, 1-16 in. to 3-16 in. above the finished size, it is only necessary to

take one rough cut on the lathe, so as to come as near as possible to the finished size, which in most cases will be from .010 in. to .035 in. larger than it should be. From this point it is more economical to grind than it would be to take a second cut on lathe, but the Landis Tool Co., from whose data this article is abstracted, do not claim that as much as $\frac{1}{8}$ in. can be ground off economically, for with the present high speed steel, it is cheaper to turn off one cut and then grind. There are, however, some cases in which as much as $\frac{1}{8}$ in. can be economically ground off, but generally it will be found that cast iron is the material on which a saving can be effected when the amount of reduction is made.

Another feature in favor of the grinder is that in taking a rough cut on the lathe less skill is required, and naturally more rapid execution results. In finishing on the grinder, the same argument applies, as every part of the machine is graduated and the correct size easy to attain. As an example of what is meant, to reduce the diameter of the work .001 in. it is necessary for the operator to turn the grinding wheel feed hand wheel one division of the scale.

It should be the intention always to carry the work being ground on two dead centres. There are, of course, times when this is not possible, but wherever practicable, no revolving of centre should be used. On the plain machines both centres remain stationary, and nothing but parts having centres in the ends can be finished; unless, as the case may be, it would be desirable to run the part in bearings. Many times this is desirable, for it enables the turning out of work more rapidly than could be otherwise secured.

One cause why work may not be round is that something has got into the work centres, or that the machine centres are not true and may be loose. If the centres of the machine are ground up nicely and those of the work are true, no difficulty will be experienced. In the grinding of long shafts it is sometimes found that they get out of shape due to their own internal strains. The piece should be supported by the work rests, which allow it to centre itself and finally become a perfect cylinder and run true. The rests are also arranged that the jaw may be clamped solidly when desired. One rest should be used for each foot of length on shafts 1 in. diameter, and for smaller shafts, a greater number should be used.

Water.

For all grinding operations, except possibly internal grinding where it is often inconvenient, a good supply of water should be used. It keeps the wheel clean and free cutting, and pre-

vents the generation of heat, which causes the work to get out of truth.

Feeds.

The size and character of the work to be finished will determine the depth of cut that should be made at each reversal of the grinding wheel. Where the part to be finished is rigid enough to stand a heavy cut, the wheel should be forced into the work until the belts are doing their utmost, at which juncture, the feed should be relieved slightly. This, of course, applies to hand feeding the wheel. When the automatic feed is used, a sufficient movement should be applied at each reversal to keep the wheel working to its maximum, and yet not be forced so hard as to get it out of shape. It is often found when taking a rather heavy cut that the wheel

does not get out of shape any more quickly than when a light cut is taken.

In cases where the wheel cuts first on one side of the work and then on the other, it is not the fault of the machine, but may be caused by an insufficient amount of water being used or the material may have been strained and equalises itself when the surface is removed. The grinding machine detects its own errors. A slight difference in sparks might lead one to suppose that the work is much out of true, but in many cases it may only be one-quarter thousandth and sometimes as little as one-tenth thousandth or even less. To overcome this imperfection, the wheel should be kept sharp, and fed on a small amount at each reversal until the work runs true.

Shipbuilding, Shipping and Marine Engineering

At no previous period in the history of the Dominion of Canada has the marine feature and its industrial importance been so much in evidence. Developments tending toward the establishment of shipyards appeal to reader and advertiser alike, and, the record pertaining to these in this section will, we are sure, be highly appreciated and be found of more or less commercial value.

PUBLICATION is made of the tender Messrs. Cammell, Laird & Co., Ltd., of Birkenhead, England, made to the late government for the construction of ships at St. John, N.B. In their tender they say:

We have carefully studied the comparative claims of numerous locations, both on the St. Lawrence and on the east and west coasts of the Dominion. With regard to the Pacific coast, we are forced to the conclusion that warship construction there would be at present carried on under such difficulties as to supplies of labor and material as to render prices for the building of your proposed warships quite prohibitive. On the Atlantic coast our consideration of suitable localities for the proposed works has mainly been confined to Sydney and St. John.

Too Much Ice at Sydney.

As regards the former, we cannot find that there is any prospect of immunity from serious interference during the winter from pack ice, which in our opinion would be most detrimental to the operations connected with the building, docking or repairing of vessels of every class, but especially with warships. We believe that strategically and practically the only location which will meet with approval is one in which there should be no possibility of interference from ice during the winter months.

We have therefore decided upon St. John, N.B., as affording the most natural and advantageous site for the pro-

posed shipyard, dry dock and other associated works, and we enclose two plans, No. 1 being a key plan showing the proposed site, and No. 2 being a complete proposition for a shipbuilding plant capable of handling the largest amount of warship construction which is likely to be required for many years.

Started to Come Here.

In order to acquire the site for the proposed shipyard, we have entered into negotiations with a firm of contractors located in Canada, and provided satisfactory arrangements can be entered into with this firm in respect to the provision and handing over of the site with the necessary buildings, launching ships, etc., etc., we are prepared to equip the same with sufficient machine tools, power plant, cranes and other requisites for carrying out the programmes of your department.

Our price for each of the four cruisers of the improved Weymouth type will be the sum of \$1,950,000. and our price for each of the six destroyers of the "River" class of the Acorn type will be the sum of \$580,000. The vessels when completed will be handed over to the Minister of the Naval Service in the harbor of St. John."

Deposit Was Returned.

Messrs. Cammell, Laird and Co. put up a deposit of \$100,000. Their tender was the lowest. The old Government returned the deposits of all tenderers except Messrs. Cammell, Laird and Co.

They did not, however, accept this tender, but left it to the new Government, which returned the deposit and decided on the new naval plan now before the Canadian people.

PORT NELSON OR FORT CHURCHILL?

WORD has been received from H. T. Hazen, the Government's harbor engineer expert, who has been surveying the harbors of Fort Churchill and Port Nelson, that he will arrive in Ottawa towards the end of February. Chief Engineer Armstrong, of the Hudson Bay Railway, is already there. Immediately upon his arrival, Mr. Hazen will lay his report before the Minister and Chief Engineer, and upon his report will depend whether or not the Government finally selects Port Nelson as the terminus of the road. Unless Mr. Hazen has found that there are insurmountable obstacles, or that the cost of keeping the harbor in shape is too expensive, Port Nelson will be the choice on account of being much nearer the wheat fields of the West, and better grades for the lines.

As soon as Mr. Hazen's report is approved, preparations will be made to send an expedition with dredging plant and all necessary equipment to the Bay, to start work first thing in the Spring on the harbor construction.

NEW SHIPYARD FOR CANADA.

THE English shipbuilding firm of Swan, Hunter and Wigham Richardson are now considering entering the Canadian shipbuilding trade, according to the statement of Clarence I. DeSola, Canadian director of the firm. For some time, said Mr. DeSola, this firm has been considering the matter, and it has now been definitely decided that if a Canadian navy is to be constructed in Canada, the great Wallsend-on-Tyne firm will tender. Already, in fact, it is understood land has been purchased by the firm in Montreal, Quebec and Halifax with the object of providing for shipyards. All classes of ships would be built, including battleships and merchantmen.

SHIPBUILDING AT LEVIS, P.Q.

A contract was recently awarded to T. Davie & Sons, Levis, to build six steel scows for the Department of Public Works. A big screw-hopper dredge for the Marine and Fisheries Department, is also under construction, and is nearing completion.

History of the Davie Co.

The history of the Davie firm is closely linked with the story of the shipbuild-

ing industry in Canada. During the years of the French regime, and later, until iron vessels displaced wooden ones, the harbor of Quebec was a great shipbuilding centre, both on the Levis and Quebec side of the river. The shipyards carried on a thriving business, which reached its zenith in 1864 during the American Civil War, when more than 100 ships were built and over 5,000 ship carpenters were employed.

It was during this period of development that Mr. Geo. Taylor laid the foundation of what was later to become the shipbuilding business of Geo. T. Davie & Sons, at Orleans Island. In 1827, Mr. Taylor received a silver cup from the Government on the completion of the "Kingfisher." In 1830 the business was transferred to Levis, Mr. Allison Davie taking charge. Eventually Mr. Geo. T. Davie, his son, succeeded him under whose able management it has expanded to its present proportions.

Salvaging Appliances.

At the present time their ship-yards at Levis are equipped with the most perfect known appliances for the salvaging and repairing of damaged vessels, and the firm owns a number of wrecking steamers. This is additional to their shipbuilding plants, the upper yard of which has a patent slip 500 feet long capable of accommodating vessels up to 5,000 tons.

It is quite evident that the picturesque old square rigger and her trim sister craft, which have played so important a part in the development of the British Empire, are gradually disappearing, never to return. Fulton's clumsy and slow-going "Clermont," 100 feet over all, has grown in a single century to the palatial trans-oceanic liners of the present day.

Future Shipbuilding Development.

While no determined effort has been made in the direction of steel ship construction in Canada, this question is one of the active issues before Canadians at the present time. Canada's progress will force developments along this line, and, already, plans for the establishment of such shipbuilding plants are under way. Montreal as the commercial capital of the Dominion, and with her great manufacturing establishments, will necessarily participate in the development of this industry to a considerable extent.

Recently representatives of Swan & Hunter and Wigham, Richardson, Ltd., of Newcastle, and Doxford & Son, of Sunderland, looked over the possible sites for yards in Montreal. These gentlemen are naturally reticent with regard to the nature of the report that they will submit to their firms on their

return, but it is understood that they are impressed with the improvements at that port due to the presence of the floating dock, and with the fact that the Canadian Vickers, Limited, contemplate the erection of a ship-repairing plant in its vicinity.

TO AUCTION LAKE STEAMERS.

CONSIDERABLE interest attaches among navigation men to the proposed auction sale at Cleveland, Ohio, of the ten fleets of the Gilchrist Transportation Co. on March 6 next by the company's receivers, Messrs. G. A. Garretson and S. P. Shane. The ten fleets will first be offered as fleets on credit terms, and in the event of no sale being made in connection with any one fleet, offerings boat by boat will be made.

The first fleet is composed of eight steamers, each capable of holding seven thousand tons, with an appraised value of \$205,000 per boat. There is an outstanding indebtedness of \$500,000 on the fleet. Fleet No. 2 consists of two boats, valued at \$220,000 each, tonnage 8,000, and built in the year 1905. There is an outstanding indebtedness of \$108,000 on the fleet. In the next fleet there are also two vessels, valued at \$274,000 each, tonnage 10,000, upon which the debt is \$108,000. No. 4 fleet consists of only one vessel, the steamer Gilchrist, valued at \$158,000, capable of holding 6,000 tons. Similarly No. 6 fleet has only one vessel, appraised at \$158,000, 6,000 tonnage, with a debt standing against it of \$30,000.

In the seventh fleet there are six steamers, each having an appraised value of \$157,000, 5,500 tonnage, and a debt of \$210,000; and in the eighth there are five vessels, appraised value \$175,000 each, tonnage 6,500 each, and mortgage of \$200,000. Three steamers constitute No. 9 fleet, the total appraised value of them being \$394,000. Each has a tonnage of 5,000, and the debt against them is \$100,000. Fleet No. 10 consists of fourteen wooden boats, with an appraised value of \$29,350.

The auction will be one of the largest in Great Lake steamers to be made in some time, and it is not unlikely that offers will be made from all parts of the country. Canadian interests will undoubtedly be represented at the sale.

Prince Edward Island.—The Government will call for tenders shortly for the construction of ferry slips for the new car ferry service from Prince Edward Island to the mainland. The terminals will be at Cape Traverse and Cape Tormentine, and their estimated cost will be from \$1,500,000 to \$2,000,000.

The Future Prime Mover, Will It Be Turbine or Motor?

The author of this paper is one of the world's foremost electrical and mechanical engineers, and his discussion of the merits of the turbine, the internal combustion engine, the internal combustion engine, the electric motor, etc., is such as to appeal to the reader as being reasonable and sound.

MR. S. Z. Ferranti, the well-known engineer, delivered an extremely interesting paper before the Greenock Philosophical Society recently on the question of turbine versus motor, and under the heading of prime movers. In the course of his paper, Mr. Ferranti said:—James Watt was practically the inventor of what we knew as prime movers, and the subject of the lecture was the most interesting problem in engineering. Besides inventing and developing the modern steam engine, Watt had turned his attention to the question of applying steam to motive purposes on what he called a "steam wheel," so getting direct rotary motion.

The work of Sir Charles Parsons in the invention and development of the rotary principle to the production of motive power by means of steam must ever be remembered as a great advance in the development of prime movers. The turbine, notwithstanding its very low efficiency as first constructed, was gradually improved until high mechanical efficiencies of conversion were reached. Before the turbine had been developed, however, another idea had been pursued with a view to simplifying the process of power generation and at the same time getting a higher economy.

The Gas Engine.

Years ago an engine was invented and built by Lenoir, in which a charge of air and gas was sucked into the cylinder at atmospheric pressure and exploded. The piston speed in this engine was low, the ratio of expansion was low, and the economy was very poor. Still, it was a step in the direction of higher economy, inasmuch as by this system a higher temperature of working fluid was obtainable. Later Otto and Langen invented a gas engine in which a flying piston was used, driven upwards by the explosion of a mixture of gas and air introduced into the cylinder without compression. The pressure of the atmosphere, aided by the weight of the piston, pressed the piston downwards, and, through an ingenious clutch and a rack and pinion, it gave rotary motion to the fly-wheel. The next move forward was that of compressing the charge of explosive mixture before firing, and so obtaining a high maximum temperature, a good ratio of expansion, and consequently much improved economy.

Engines of this type belonged to a class of prime movers with "high negative work." In this form of engine the positive work of the explosion had to have deducted from it not only the friction of the engine, but also the amount of work required to compress the charge which constituted the negative work of the cycle. There was a further deduction—that of the friction of the engine or of a separate pump while doing negative work. These deductions would render this class of motor useless were it not for the high mechanical efficiency of the parts used for carrying out the cycle. In the gas engine the negative work was high, but not so high as to form a serious difficulty.

The Diesel Engine.

In the more economical Diesel engine, in which very high pressures were used so as to get a high enough temperature to burn the oil as it sprayed into the cylinder and give a high ratio of expansion, the negative work was a much more serious difficulty—so serious, in fact, in the first Diesel engine that it required more power to overcome the friction and negative work than the engine was capable of giving, so that it would not even drive itself, much less was it capable of doing any useful work. The cycle of the engine was modified, therefore, in the direction of making it less perfect theoretically, and so enabling the engine to become the success which it now was.

No General Monopoly.

The internal-combustion engine and the steam turbine were now competing for premier place in furnishing the world's power. The turbine, though less economical in actual fuel consumption, had many great advantages, and for large powers it was practically unassailable. For small powers it was naturally uneconomical. It seemed to be clear that for small powers the internal-combustion reciprocating engine was in every way the best. At the other end of the scale the turbine was the only means of filling requirements to-day. In between these two extremes there was a doubtful dividing line, where either form of engine might serve the purpose, according to the conditions of each particular case.

As the turbine became larger, so it was easier to construct, and it also be-

came more economical. As the gas or oil engine became larger the natural difficulties increased. On the other hand, as the turbine was reduced in power its economy fell off badly, and it was difficult to make of satisfactory design, while the internal-combustion engine became a most satisfactory and economical machine in small sizes. He thought that this division of the means of power production by large and small units between the rotary and reciprocating machine was almost a natural law, and that those who sought to evade it must either invent some new principle or court endless trouble, expense and failure.

To-day, however, with a complete disregard of these principles the advocates of the Diesel engine were spending vast sums of money on its development. Even this usually all-powerful force might not prove enough to make a wrong principle right. They were told of the wonderful successes of large oil engines in Germany and elsewhere, but few people had any conception of the failures and breakdowns which had occurred, and which were occurring repeatedly with the large experimental engines which had been constructed. In Germany especially, where so much had been done in this direction, they carefully avoided informing the foreigner on these points. It was well known, of course, that the higher the temperature of the working fluid the higher was the economy that could be obtained. High temperatures have proved, however, very difficult to work with. As an example of this the low working temperatures of turbines for marine propulsion might be pointed out.

Ferranti Turbine.

Seeing that the difficulties were mechanical and that great advantages could be obtained if these troubles were overcome, he commenced experimenting some years ago, and had now, after many failures and the expenditure of much money and time, produced a turbine which, at the highest temperatures and with great and rapid variations of temperature, was quite free from mechanical troubles. Indeed, he believed that this turbine was perhaps the strongest from a mechanical point of view that had yet been produced. Moreover, contrary to what might have been expected with a high temperature machine, it ran with certainty with a blade

end clearance so small that it was almost negligible from the point of view of leakage loss, and the fear of the possibility of stripping appeared to have been effectively removed.

In this turbine he superheated the steam initially, and after the first expansion, and while it was still superheated, he resuperheated it before it did its work in the second stage of the turbine. After this it was exhausted in a superheated condition through a regenerator to the condenser. Although the turbine was of the reaction type, no balance dummy was used. The whole of the end load was taken on a specially constructed thrust, thus saving steam leakage. The steam was worked as a gas at high temperature throughout the turbine, and this, coupled with the many improvements referred to, had given very good results. The 5,000 h.-p. machine, which had now been running some time, when tested at a load of two-thirds full power, had given a shaft h.p. on 7 lbs. of steam.

It appeared that when this turbine was run at full load under favorable conditions it would take less than 6 lbs. of steam per shaft horse-power, and that the system, under the conditions named, would have a thermal efficiency of over 24 per cent., corresponding to an oil consumption of about .55 lb. of oil per shaft horse-power. So far as he could see, this system, when applied on a large scale, would be capable of giving an over-all thermal efficiency of 29 per cent. With a high temperature steam turbine of large size generating electricity for all purposes on land, they had the advantage of a machine of the highest efficiency which was not limited to oil for its fuel. It was probable that as improvements were made, the whole of the coal used for firing these large units would be gasified, and the by-products recovered. The great problem for this country was to so utilize the coal as to make it fill their every requirement.

The Electric Motor.

The electric motor which gave its power in a rotary form, and which was supplied from very large power stations was displacing all forms of large power engines. It was probable, therefore, that in future, small prime movers would be required to propel cars and boats, and that all stationary motors would be electric. Reciprocating engines would be used no doubt for a long time, but they could only be regarded as makeshifts, and as soon as an equally efficient machine for any particular purpose was developed it would displace the reciprocating motor. It was difficult to predict the form of the prime mover

of the future, but in search of the highest economy, and with the limitations of temperature imposed by known materials, one was inclined to look to electricity, converting the energy of the fuel at low temperature and giving its power in rotary form, as the most likely eventual solution.



STEEL WORKS IN THE ORIENT.

A NUMBER of prominent Japanese business men have arranged to establish near Yokohama a plant for the manufacture of steel tubes and tubing. The annual imports of steel tubing and pipes total \$2,000,000 to \$3,000,000, and it is believed by interested Japanese captains of industry that this enterprise will prove profitable. The machinery for the new plant was purchased in Germany, because of the prices quoted, and also, it is said, because the machinery was considered more satisfactory. The necessary capital has been raised for the new plant, and the machinery will be installed during the present year.

Iron Works in China.

There is but one modern iron works in China—the Hanyang furnaces and mills at Hankow, which has shipped pig iron to the United States. Similar in-

dustries are to be started elsewhere in China.

One of three smelting furnaces to be erected at the Pengehihu iron foundry in Manchuria, near Liaoyang, which has been started by Okura & Co., Tokyo, has been completed, and the manufacture of pig iron is to be started shortly. The materials for constructing the smelting furnace were supplied by the Imperial Iron Foundry at Wakamatsu, Japan, and all the pig iron produced at the iron foundry in Manchuria is to be delivered to the Wakamatsu foundry. When the Pengehihu foundry is completed, the annual output of pig iron is estimated at 120,000 tons, representing \$2,400,000 in value.

It is reported that the Germans at Tsingtau intend to open iron works in which Chinese capital will be allowed to participate. It is proposed to start upon a large scale, with a capital of \$10,000,000, to work the iron coming from Chinlingehem, which is near the Shantung Railway.

Correspondence in the North China Daily Herald dated at Hankow, January 6, says: Some of the foreign employees at Hanyang iron works and the Pinghsiang collieries have been re-engaged. The former are to arrive in January, the latter are expected in March. Full work will again be begun.

Canadian Railroad Extensions and Betterments

Being a record of progress and development in the opening up of new territory, concerning additions to equipment and provision being made or projected to secure an uninterrupted and otherwise efficient transportation service to meet the domestic and international requirements of the Dominion of Canada.

G.T.R. SHOPS FOR PRESCOTT.

SYMPATHY, but little encouragement was given the town of Brockville by the Private Bills Committee of the Legislature, on Tuesday, Feb. 25, when the town, through its member, attempted to block approval of the bill covering the agreement between the Town of Prescott and the Grand Trunk for the removal of the railway shops from Brockville to Prescott.

A. E. Donovan presented the memorial of the Brockville Board of Trade, setting forth the various reasons why the company should not be allowed to remove its shops. Hon. Mr. Lucas questioned whether there was any ground on which the Legislature had a right to interfere. Mr. Donovan thought the sections that declared against one municipality taking industries away from another might furnish that ground, but the chairman did not see eye to eye with him.

“We sympathize with you,” he remarked, “but I don’t see that we can help you.” The bill was reported.



TRACK LAYING ON G. T. P. AND N. T. R.

COMPLETED figures for the year ending December 31, 1912, show that during that period 969.90 miles of new track were laid by the Grand Trunk Pacific and National Transcontinental combined. This amount, in comparison with the preceding twelve months is divided as follows:

	1911.	1912.	Inc.
G. T. P.....	254.00	608.75	354.75
N. T. R.....	280.25	361.15	80.90

Combined system 534.25 969.90 435.65

The new mileage of the two roads respectively added during 1912, is made up as follows:

Grand Trunk Pacific.

Main Line (between Yellow-head Pass and Prince Rupert) Regina towards International Boundary	128.00
Talmage to Weyburn, Sask....	0.25
Oban to Battleford, Sask.....	48.50
Biggar towards Calgary	104.00
Battleford towards Wainwright	4.00
Tofield towards Calgary	92.00
Bickerdike to Brazeau	56.00

	608.75

National Transcontinental.

At various points between—

Mileage 109 and 153, East of Quebec Bridge	33.00
Mileage 1 and 8.6, East of Quebec Bridge	7.50
Mileage 288 and 419, West of Quebec Bridge	84.75
Mileage 168, West of Cochrane, Ont., and 102 East of Lake Superior Junction, Ont.....	235.90

	316.15



CANADIAN METALLURGICAL LABORATORY.

THE results accomplished by the Canadian Department of Mines in its experiments in ore dressing and concentration are of particular interest to those Canadian districts in which large deposits are found of low grade iron ore. Although it is difficult for Canadian furnaces to obtain sufficient quantities of high grade ore, yet immense deposits of low grade ore are available as soon as means for concentration and elimination of impurities are made commercially available. In many cases, sulphur, phosphorus and titanium are present in excess and in the raw state, the ores are valueless.

During the past year, the Department of Mines has made experiments on iron ores from the Provinces of Ontario, Quebec, New Brunswick and Nova Scotia. In these experiments Grondal magnetic separators have been employed. The aim has been to treat the ores under conditions which approximated commercial practice.



HAMILTON'S INDUSTRIAL PROSPERITY.

INDUSTRIALLY Hamilton is growing in many ways. A new factory for the manufacture of "Ever-sharp" pencils, for which most of the capital was raised locally, will soon begin operations.

Another indication of the industrial progress of Hamilton is the fact that the Sawyer-Massey Co., manufacturers of gas tractors, steam traction and threshing machines, etc., has increased

its output by 80 per cent. since the re-organization of the company three years ago. There are now 639 men employed in the works, which three years ago employed 220. The company is now completing a large addition to the building, which is used for assembling the engines and tractors, and which will increase the already large space used for this purpose by one-third.

The earnings of the company for the past year are not yet known, but the volume of business has been greater than any one year preceding, as indicated by the comparisons given above.



CANADIAN LOCOMOTIVE CO.

A REPORT from the general manager of the Canadian Locomotive Co. states that the work of extending the plant is going ahead favorably. During the year 1912, 81 locomotives were turned out as compared with 51 in 1911 and 56 in 1910. The new tank and tender shop have already been completed and a new iron foundry and yard crane runway are well under way, and should be completed by the middle of April. When these extensions are completed the plant will have a capacity of 12 locomotives per month.

New Erecting Shop.

A new erecting shop is also under way, which should be finished by next fall. This will increase the capacity to 15 locomotives per month. A new machine shop and blacksmith shop and extensions to the boiler shop are also planned, and it is expected that these improvements will be ready for business by the end of 1914, which will mean that the output by that date will be one locomotive per working day.

70 Per Cent. of Orders Rejected.

If these improvements go ahead without unforeseen delays and are completed according to schedule, the capacity of the plant will have been considerably more than trebled within two years—an increase that is fully justified by the steady and increasing demand for locomotive equipment. As a matter of fact, during the past year the company's acceptance of orders has been controlled absolutely by its capacity, on which account fully 70 per cent. of orders received have been rejected.



Belgo-Canadian Marble and Power Company, Limited, incorporated at Ottawa, with \$500,000 capital, to conduct mining operations, with head office at Montreal: Incorporators, Napoleon Turcot, Arthur Erement, Louis Loranger, Alban de Sars, Alvila Chausse, all of Montreal.

ELECTRIC RAILWAYS IN CANADA.

ELECTRIC railways in Canada carried a total of 1,435,525 tons of freight during the last fiscal year, and earned a total of \$1,025,371 from that source. Their earnings from passenger traffic in the year amounted to \$22,007,750.

The report on railway statistics of Canada, issued by Hon. Frank Cochrane's department, shows that there are to-day thirteen radial lines of over fifteen miles in length which do a freight business among the more than fifty electrically-operated lines in Canada. This does not include the street railway lines in large cities which also carry freight; Montreal Street Railway, for instance. Dealing only with radial lines, the following interesting figures are shown in the report:

	Mileage.	Freight Carried.
Brantford and Hamilton....	23.00	4,978
British Columbia	200.22	256,083
Chatham, Wallaceburg and Lake Erie	38.94	71,347
Galt, Preston and Hespeler	17.81	153,729
Grand Valley Railway.....	38.29	264
Hamilton, Grimsby and Beamsville	22.00	64,160
Hamilton Radial Railway..	25.00	11,951
London and Lake Erie Railway	27.50	6,995
Montreal Terminal Railway	18.22	91,302
Niagara, St. Catharines and Toronto Railway	47.76	261,890
Toronto and York Radial..	72.43	60,490
Windsor, Essex and Lake Shore	36.16	26,781
Winnipeg, Selkirk and Lake Winnipeg	21.44	4,556

First track mileage of electric railways in Canada has almost doubled since 1901, the total of first track standing to-day at over 1,300 miles. Their gross earnings in 1912 amounted to \$23,499,250, an increase of \$3,142,298, over the previous year. Carriage of mail and express brought earnings of \$78,818; other car earnings were \$67,022, and miscellaneous earnings from advertising, rents, etc., added \$320,287. Sale of power does not amount to a very great sum as yet, the total revenue from this source in 1912 being but \$37,083. Comparison of the respective figures shows that earnings of electric railways are increasing at a percentage greater than those of steam railways, the gross earnings of the electric railways having more than doubled in the last six years. In this connection the departmental report says:—

"An outstanding feature is the steady rise of earnings from freight. In 1901 the total from this source was \$95,082. In 1904 there had been an increase to \$182,143, and in 1906 to \$288,105. In 1912 the earnings from freight reached \$1,025,372—showing the extent to which that aspect of public service had grown in twelve years."

BONUSES FOR NEW INDUSTRIES.

THE Calgary Albertan says that the Province of Saskatchewan has adopted legislation in a mild form to prevent municipalities from giving bonuses to industries. The province did not, however, go as far as the Industrial Bureaus of the western cities desired, and permits the cities to exempt industries from taxation for ten years and to give them free sites. It would have been well if the province had gone still further, although the advance made is not to be despised.

The industrial organizations of the live cities of Western Canada are so vigorous in campaigning for new industries that the establishments that are being courted so persistently show some disposition to put city against city and get them bidding against one another. In another part of the paper, the Albertan publishes a letter from a gentleman from across the line who sees in Western Canada a golden opportunity for manufacturing glass eyes and wooden legs. The enterprising gentleman asks for everything in sight, and adds, that if he has overlooked anything that he would be much obliged if the Calgary people would bring it to his attention. The application is so extreme that it reads like a burlesque. However, we are assured that the request is made, by a real person in good faith, believing that these Western enthusiasts will stop at nothing in the effort to secure industries.



NEW INDUSTRY FOR WELLAND.

THE manufacture of a special heavy cotton duck for use in the making of automobile tires is being started in Canada. Finished material at present is being imported under Customs charges ranging from 20 per cent. to 27½ per cent., varying according to weight. The rapid growth of the tire industry in Canada now offers a particularly attractive field for the manufacture of tire duck, and the Empire Cotton Co., Ltd., in connection with which the new industry is to operate, can turn the product out under the most economical conditions.

Located at Welland, Ont., the plant is geographically in the centre of the tire trade in Canada, with both the Grand Trunk and the Wabash Roads offering railroad facilities, and with the advantage of the Welland Canal at the very door providing low water rates for incoming raw and outgoing manufactured material. The Goodyear Tire and Rubber Co. in Bowmanville, the Dunlop Tire Co. in Toronto, the Independent Tire Co. in Berlin, the Dominion Tire Co. now building also in Berlin, and the Gooderich Co. each opening up at Nia-

gara Falls, will be able to take advantage of a low manufacturing cost, a maximum of freightage, and the absence of Customs charges on the large quantities of the tire duck now being used in tire making.

The Empire Cotton Co., Ltd., which is the name of the new concern, and is controlled by Smart, Woods, Ltd., of Montreal, has 36 acres of land and a small fixed assessment for a period of 20 years. It will be under the supervision of Mr. C. T. Grantham, who is well known as the Canadian pioneer in the cotton duck industry, which he started in Yarmouth, N.S. Mr. Grantham is also well known in Hamilton, where he organized the Imperial Cotton Co. a number of years ago, which has been particularly successful.



WATER WORKS INEFFICIENCY.

NINETY-FIVE and a half million dollars are invested in waterworks systems in Canadian towns and cities. The annual outlay for maintenance, exclusive of interest, amounts to \$3,435,199. There are in all 5,215 miles of mains in use, and the total daily consumption of water passing through these reaches 360,477,638 imperial gallons. These are the figures obtained by an investigation just completed by the Commission of Conservation, the results of which are being published as a report on the Waterworks of Canada. They indicate something of the magnitude of the investments that are placed in Canadian public service utilities. By far the larger number of these plants are owned by municipalities, but a few of the smaller ones are owned and operated by private individuals or corporations.

A Glimpse at the Details.

An examination of the details which go to make up these totals present some interesting conditions. Thus, the estimated cost of supplying water varies from seven cents per 1,000 gallons for the municipalities of Nova Scotia to 23 cents per 1,000 gallons for those of Saskatchewan, with costs in the other provinces ranging between these extremes.

In Saskatchewan, where the cost of delivery is higher than in any of the other provinces, the amount of water used is much less. In the City of Moose Jaw, for example, the daily consumption rate is only 15 gallons per head of population. All the water is metered and no flat rates are levied. The meter rates range from 10 cents to 25 cents per 100 cubic feet, somewhat below the average for the province. In the matter of meter rates, however, there is an exceedingly wide variation in Saskatchewan. In one small town these rates

range from 25 cents to 75 cents per 100 cubic feet.

Waste of Water.

In Eastern Canada the consumption rate is more uniform, but there are indications of considerable waste in many cities. Last year an Ontario city employed experts to ascertain the cause of waste. They found some serious leaks in mains, as well as wastage by individual users. The expert engineer in his report says:

"Water is pumped at the present time at the rate of about 190 Imperial gallons per capita daily, and at least three-fourths of this water is wasted without being of benefit to any one. Some of this wasted water is due, no doubt, to leaks in the pipe system, but probably most of it escapes from leaky plumbing fixtures in the houses and shops of the city." One hundred and ninety gallons of water weigh nearly one ton, so that this city is each and every day in the year pumping four and a half tons of water for each family of five persons. The average consumer may truthfully say that he is not using that amount of water, yet he is paying for it, and, if of the well-to-do class, probably for more than that amount.

The above example is not unique in any way, for there are very few cities on the North American Continent in which enormous water waste cannot be found, and this, despite the well-known fact that it is only necessary to install meters to put a stop to it.

The Canadian who is really patriotic cannot do better than consider carefully this question, particularly as far as it affects his own municipality. It is axiomatic to a waterworks expert that fifty gallons of water per head of population is ample, and that—unless water is used for irrigation or similar purposes—what is pumped over and above that amount is wasted.



BRIDGE CONTRACT AWARDED.

THE Dominion Bridge Co., Ltd., Montreal, have just been awarded the contract for the superstructure of the new spandrel arch bridge which is to replace the present suspension bridge at St. John, N.B. The bridge will have a span of 565 feet and will be 50 feet wide overall, to accommodate two street car tracks, double roadway and two sidewalks. The flooring is to be of reinforced concrete overlaid with creosoted wood blocks. The cost of the superstructure will be about \$275,000 and the contract is to be completed by June 1st, 1914.

MACHINE SHOP METHODS ^A_N^D DEVICES

Unique Ways of Doing Things in the Machine Shop. Readers' Opinions Concerning Shop Practice. Data for Machinists. Contributions paid for.

DRILL DRIFT CONNECTION.

By D. A. Hampson.

IT is a common practice on drilling and milling machines to attach the knock-out drift by a light chain to some convenient part of the frame of the machine. The drift is commonly provided with a hole near the head end,

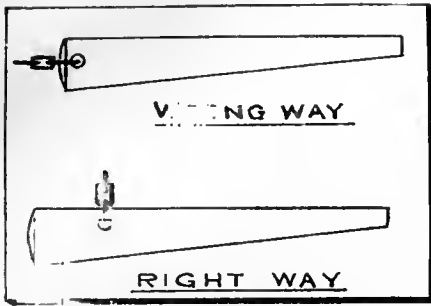

DRILL DRIFT CONNECTION.

through which the last link of the chain is passed. However, it generally happens before very long that some fellow gets that link between the head and his hammer and cuts it in two. If the hole is drilled so far away from the head end that the last link cannot swing round in line with the drift all trouble will be avoided.

DRILL JIG FOR CONNECTING ROD BEARINGS.

By H. R.

THE very simple jig here illustrated has proved highly satisfactory for drilling connecting rod bearings. The base (A) is of cast iron machined inside the Vee to an angle of 60 degrees, and on the top and bottom bearing faces marked (A1). The top (B) is also of cast iron, machined all over, into which are pressed the steel bushings (C), locating the bearings sideways and in the bore. The bearing (D) and top portion (B) are put into position on the base (A), after which by turning the knurled

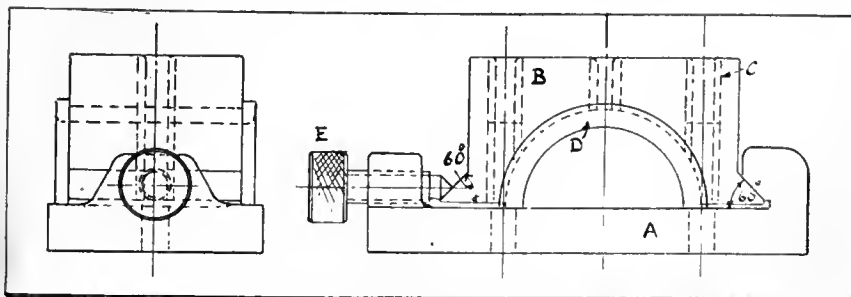

DRILL JIG FOR CONNECTING ROD BEARINGS.

screw (E) the former is securely fixed and ready to be drilled.

A SHAPER KINK.

By J. Davies.

THE illustration shows a very simple, yet effective shaper kink, that will probably appeal to those who have shaper work to perform. The writer saw the method adopted when two long recesses were being machined, in an irregular casting. The difficulty to be overcome was, of course, the drag of the tool on the return stroke. To eliminate this, a common door hinge was clamped to the back of the tool as shown

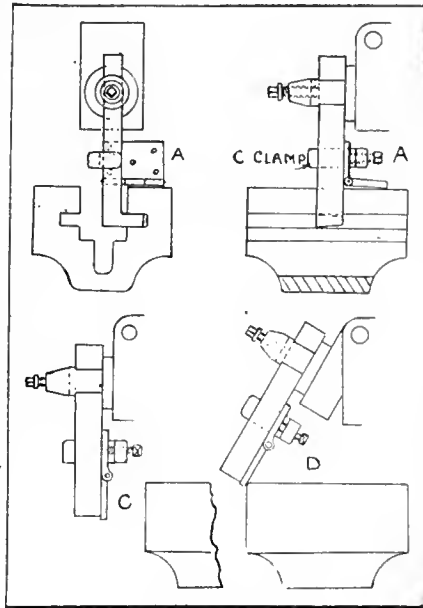

A SHAPER KINK.

in the cut at (A). This was done in such a manner that the hinge was free to swing, on the cutting stroke. At the end of this stroke (C), the hinge falls

down at the back of the tool, and on the return stroke (D) holds the tool above the work. The amount of lift may be regulated by raising or lowering the hinge on the back of the tool. In cutting side slots in very deep castings, it would be necessary to lengthen the side of the hinge that falls.

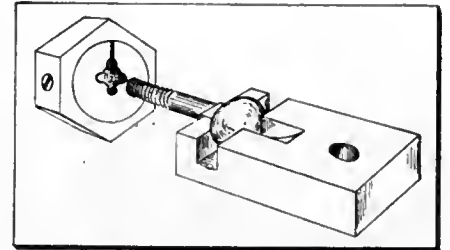

SCREWING FIXTURE FOR LATHE.

SCREWING FIXTURE FOR LATHE.

By D. A. Hampson.

IN getting out a thousand patented articles there were required an equal number of bolts $\frac{3}{8}$ in. x $4\frac{1}{2}$ in. These had to be threaded the full length and sized down to fit into a $\frac{3}{8}$ in. V thread, tapped hole. On short notice, it was impossible to secure bolts to suit, so we rethatched the nearest in stock for our purpose. Two special fixtures had to be made,—one for holding the die and the other for the bolts. The die holder was a piece cut from a bar of "hex" stock, chucked in the lathe and bored to receive the die. This was done in the lathe where it was purposed to do the work and the piece was not taken out of the chuck. It was drilled for two set screws.

The holder for the bolt was a piece of steel $\frac{3}{4}$ in. x 2 in. x 4 in., in which two slots were milled and a hole drilled for the clamping bolt. It was bolted to the cross slide of the lathe and centered up with the die. The "jaws" were well casehardened. When operating a bolt was dropped into the holder, the carriage being run up until it entered the die, after which the lathe "did the rest." When run up full length, the lathe was reversed. An excellent and rapid job was the result, while the tools were of the cheapest kind, yet substantial enough to last for several repeat orders.

PROPORTIONAL REDUCTION OF VOLUME.

By R. G. Dickens.

SOME TIME ago the writer was asked by a friend if he could make a set of drawings for the purpose of model-making that would effect a reduction in volume of 1-27 the actual size. I readily accepted the job and went to work, only to find, however, that my method of procedure was away off. After studying the trouble for some time, I found my mistake and immediately made a note in my note book which reads as follows:—

To effect a proportional reduction in direct relation to the reduction of volume, extract the cube root of the desired ratio, and divide the original figures by the result.

Example:—Reduce a cube 6 x 9 x 12, containing 648 cubic inches to 1-27 of its size.

Cube root of 27=3,

6 ÷ 3=2,

9 ÷ 3=3,

12 ÷ 3=4,

Volume of required cube=2x3x4=24

Volume of original cube=6x9x12=

648=1-27.

This, while a perfectly rational way of arriving at the result, is yet one of those simple things easily forgotten.

HANDY SHOP TOOLS.

By J. H. R.

THE accompanying sketch illustrates a couple of handy tools for use in the tool room.

Fig. 1 shows a hammer head, with soft metal faces to prevent disfiguring finished work. The soft steel head is in-

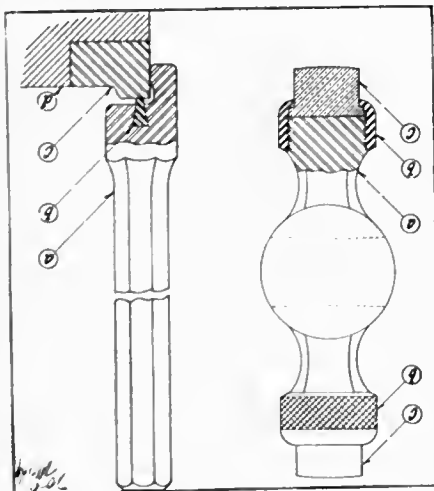

FIG. 1. FIG. 2.
HANDY SHOP TOOLS.

dictated at (a) and (b) is the knurled nut which secures the pieces (e.e.) to the head. These latter may be of fibre,

leather, copper, brass or other substance suitable for the work in hand.

Fig. 2 is a useful tool for upsetting punches when under size or when sheared.

A piece of chisel steel, the required length and forged to shape on the end is indicated at (a); into this the hardened piece (b) is secured in the dovetailed groove. The tool is used in the manner illustrated without danger of burring the edge by a misplaced blow of the hammer.

A PISTON RING TESTING MACHINE.

By H. R.

THIS will be found a very useful apparatus in automobile shops, or where piston rings are produced in quantities, and where every fraction of un-

of manufacture being clearly seen on the enlarged view. The lever (B) is fulcrumed on the solid bearing (G), which is attached to the bracket (H) by two screws. In the middle of the lever (B) will be noted the knife edge. This takes the whole pressure exerted on the piston ring. The lever (B) is composed of two plates, riveted together, and arranged with a screwed tail to carry the balance weight (I). When the levers are not in use, the link (J), out of which is drawn the screwed piece (K), is held up by the knurled screw (L), which is prevented from turning by the screw (M).

As pressure is applied to the piston ring, the rollers (N), which are fitted into a cage made up of two gunmetal castings (O) and screwed to the base (A), take care of any movement. The lever (C) is fulcrumed at (P), and is held to the base by the links (F) and a steel bar passing through them and a small bracket (Q) screwed to the base

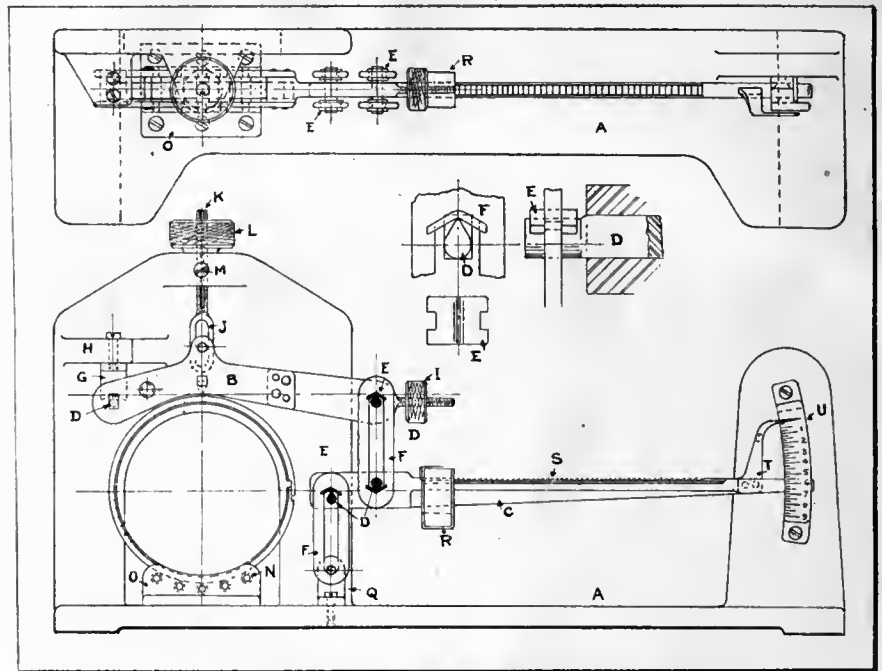

A PISTON RING TESTING MACHINE.

necessary friction needs be detected. By this instrument it is possible to find the pressure in lbs., ounces, etc (according to the graduations of the machine), that it will take to close a piston ring, therefore making possible that all the rings in an engine cylinder will have the same elastic tendency, and, consequently, doing an equal amount of work. The construction of the apparatus is as follows:

On a cast-iron frame (A) are carried a series of levers (B) and (C). These are on the weighing machine principle, and have fitted hardened steel pieces of rectangular section forming the knife edges (D), which hang in the hardened steel pieces (E), and so arranged as to provide the bearings. They are simply pressed into the links (F), their method

(A). The lever (C) carries the poise (R), and has a series of knitches milled on the top (S). To the end of the lever (C) is fastened the pointer (T), which automatically registers the load on the ring on the graduated plate (U).

It may be said why so much leverage, but as it takes about 18 lbs. to depress a piston ring of 2½in. dia. x ¼in. x 3-32in., the reason is quite apparent.

Cobalt, Ont.—A 30-stamp mill will be erected by Goldfields, Ltd., of Larder Lake. Goldfields, Ltd., took over the Harris-Maxwell Proprietary and Tourneville claims.

DEVELOPMENTS IN MACHINERY

A Record of New and Improved Machinery Tending Towards Higher Quality and Economical Production in the Machine Shop, Blacksmith Shop or Planing Mill.

NEW WESTINGHOUSE MOTOR.

A NEW Westinghouse motor, just placed on the market, is especially designed for driving bending rolls, raising the cross rails of planners and boring mills, moving the tail-stocks of large lathes, and similar service requiring motors with special torque characteristics. The special feature is a heavily compound field, most of the excitation being due to the series coils. The torque, therefore, increases rapidly as the current input increases, a necessary characteristic in starting a cross rail or taking a plate through bending rolls. The shunt field winding limits the no-load speed to approximately twice the full load speed so that racing is impossible.

Mechanically, these motors are exceptionally strong. The frame is made of rolled steel, the shaft of axle steel, the bearings large, and dust and oil proof. The commutation is practically sparkless, due to the use of commutating poles and careful design of the commutator and brushes. It is claimed that these machines require very little attention, as lubrication is automatic and the brushes rarely require renewal.

These motors are made in capacities

of from 3 to 40 horsepower, for 230 volt direct current circuits by the Westinghouse Electric & Mfg. Co., East Pittsburgh, Pa.

of from 3 to 40 horsepower, for 230 volt direct current circuits by the Westinghouse Electric & Mfg. Co., East Pittsburgh, Pa., and equipped with a Westinghouse latest pattern type S K. adjustable speed motor with belt transmission. It will be noted that the tool

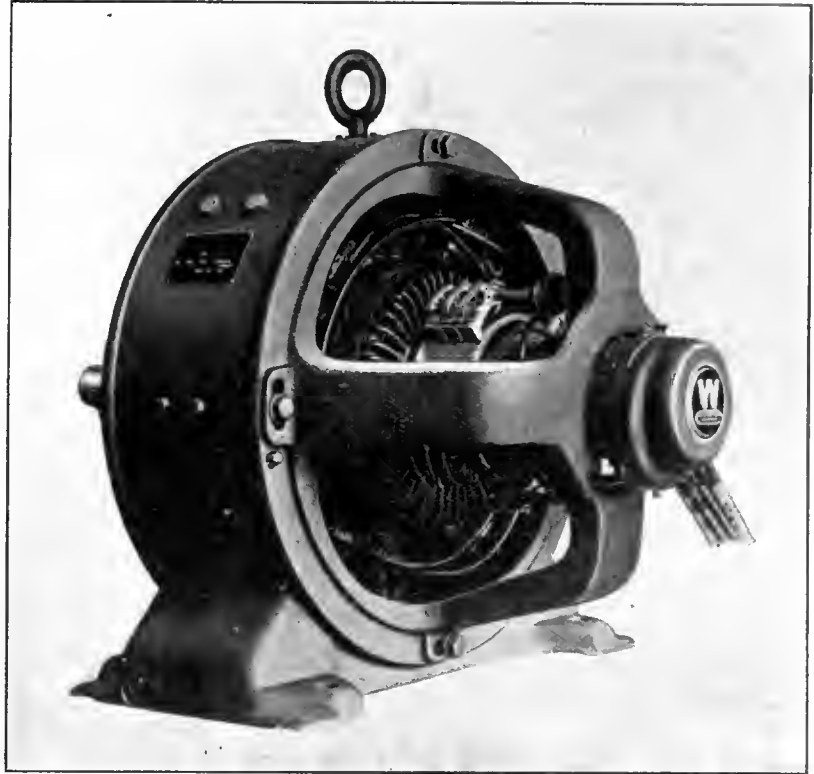

NEW WESTINGHOUSE MOTOR.

MOTOR DRIVEN GEARED HEAD LATHE.

THE text and illustration refers to a motor driven geared head lathe made by the Hendey Machine Co., Tor-

rest is of the turret type, designed to hold four tools capable of being rotated from one position to another at the will of the operator, a highly satisfactory arrangement when machine work calling for several different operations has to be performed on the same piece in a chuck, and when the service of a complete turret manufacturing lathe would not be warranted.

This equipment is offered as a low cost motor drive in cases where it is found unnecessary to supply a motor of sufficient power to meet the maximum capacity of the lathe. The work being light in character makes it convenient to use a motor of moderate power, and a belt for transmission in place of chain and sprocket. The motor is mounted on a hinged plate which secures the necessary belt tension. The flexibility of the belt drive does away with the use of a friction clutch equipment on the power shaft, and there is also no occasion to supply a guard as for a chain drive. The controlling panel shown is comparatively small in size.

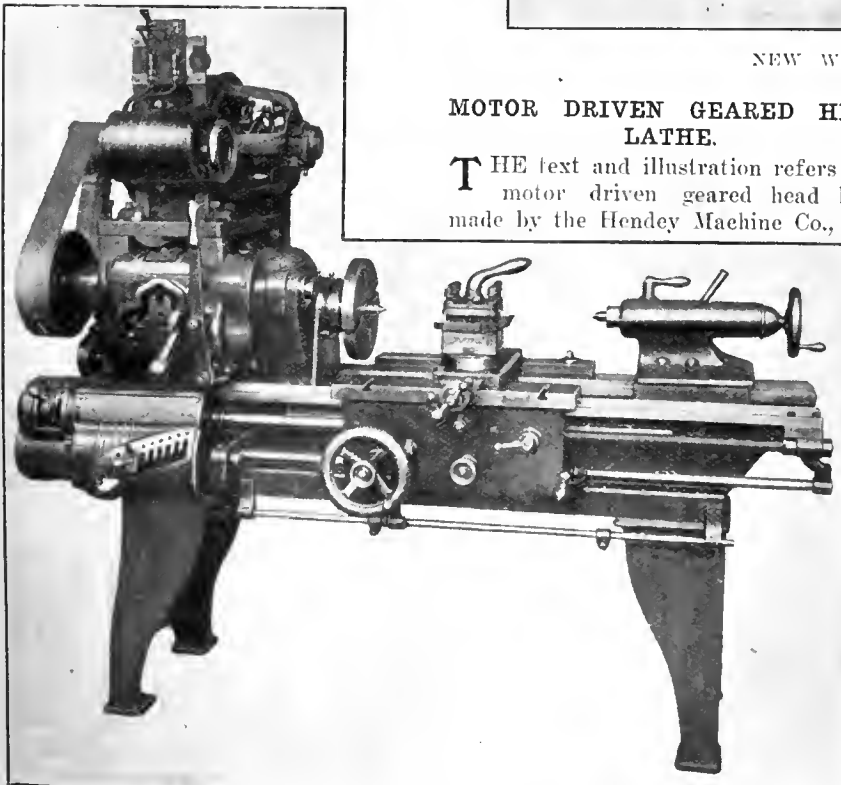

MOTOR DRIVEN GEARED HEAD LATHE.

and can, therefore, be attached in front of motor. A drum type controller can be furnished in place of panel if desired; this would be attached to the bed and leg directly below the head-stock in a vertical position within easy reach of the operator.

Motors for this type of drive can be direct or alternating current, constant or variable speed, and the horse-power for various sizes of lathes will approximate as follows:—Swing of lathe, 12in., 14in., 16in., 18in., 20in., 24in.; horse-power of motor, 1-1½, 1½-2, 2-3, 3, 3-4, 4-5 respectively.

Slow speed of motors, the makers state, should not exceed 1,200 r.p.m. for lathes up to and including 18in., and 900 r.p.m. for 20in. and 24in. lathes.



MOTOR DRIVEN DISC GRINDER.

THE accompanying illustration shows a motor-driven-lever feed disc grinder recently placed on the market by C. H. Besly & Co., Chicago, Ill. The improvement on the older type of grinder by the addition of a geared lever feed table and electric motor drive makes it indispensable for making, perfecting and finishing flat surfaces of metal, wood, and other material. It may be operated by unskilled labor, and work to which it is adapted is done in a fraction of the time required by a lathe, planer, sharper, miller, file or other types of surface grinders.

Grinding is performed by emery or other abrasive cloth sheets, called circles, glued to the faces of steel disc wheels, which are usually 12 inches to 52 inches diameter, according to the size of the piece to be ground, and of suitable thickness (½ in. to 1¼ in.) to withstand the stresses and requirements

met with in actual service. The disc wheel is made of wrought steel, specially treated to eliminate strains in the metal. It is machined with great care and runs "dead true" in perfect balance at a considerably higher speed than is practicable with the ordinary solid emery wheel. When "circles" become worn, they may be removed from the wheels and new ones cemented and pressed on. The speed at which the abrasive travels varies. On the softer metals, 7,500 feet, and on the harder material, 6,500 feet a minute are the average speeds used. Exhaustive tests covering a variety of disc grinder work show that a total amount of feeding pressure exerted in rough grinding different work varies from a few pounds up to 800 pounds. In exceptional cases, a feeding pressure of 100 pounds per square inch of ground surface area can be used without destructive effect on the circle.

The work to be ground is laid on the face of the disc wheel and the grinding is done by means of the lever feed. By the use of the adjustable table, work may be held in any desired position and forced against the abrading disc by a hand lever with sufficient pressure to secure full efficiency of machine and circle, without undue exertion on the part of the workman. The lever feed table provides sufficient feeding pressure to rough grind quickly, and has angular adjustments and micrometer stop screws, so that work may be ground accurately to required angles and sizes. This work table made it necessary to provide additional driving power and improved means for receiving the heavy end thrust of the spindle, consequently, a motor drive was selected. This grinder is driven by a 15 h.p. motor, manufactured by the Westinghouse Electric & Manufacturing Co. This

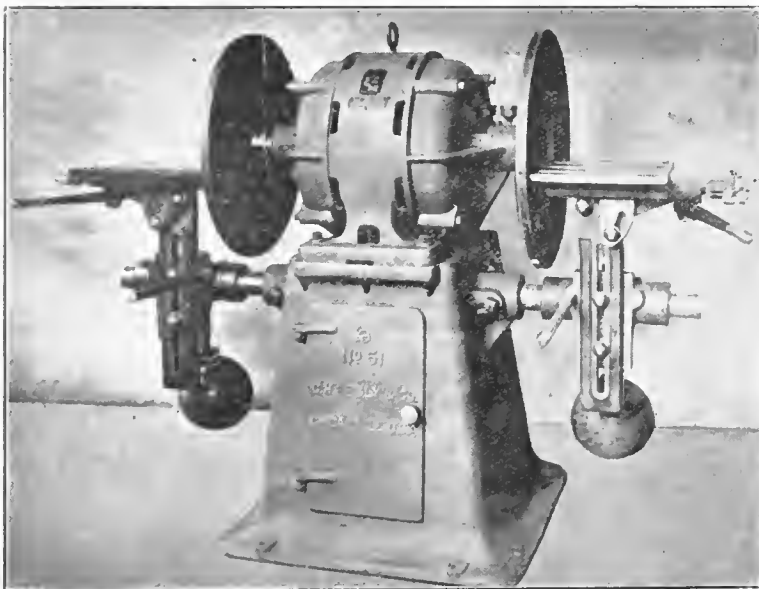

MOTOR DRIVEN DISC GRINDER.

has extra heavy thrust bearings, brackets and shaft, and the windings are well braced in order to withstand the heavy overloads to which the outfit may be subjected. By careful design, it has been possible to obtain a compact as well as rugged unit.



A UNIVERSAL MILLER.

THE illustration shows a 20 x 7½ x 17-in. universal miller, made by the Oesterlein Machine Co., Cincinnati, Ohio. The column is made with a straight-line back; the back gear is placed inside the column below the spindle, and the arbor is driven with a clutch in front of the spindle. The col-

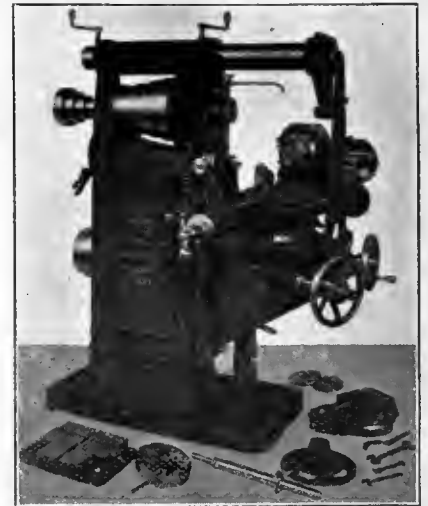

OESTERLEIN UNIVERSAL MILLER.

umn is provided with oil wells for the spindle, and the knee is clamped with a taper sliding gib, clamping along the whole face of the column, and operated with one lever. Hand wheels are provided for cross and vertical adjustment. There is also an automatic cross-feed.



U. S. STEEL TONNAGE.

AT the present rate the unfilled tonnage of the United States Steel Corporation for February will show about the same decrease as that of January, or slightly over 100,000 tons. There has been some heavy buying of plates and car shapes by equipment companies recently, one order placed within the last few days calling for 65,000 tons of plates and shapes for cars to be built for the Norfolk and Western. The largest enquiry in the present market is for 4,000 cars for the Big Four. The plate market at present is better than for months, and there seems to be no let-up in sight due to the heavy buying by roads in the equipment lines.

COMPRESSED AIR AND ITS MEASUREMENT.

A PAPER entitled "Some Applications of Compressed Air and its Measurement" was recently read before the Liverpool Engineering Society. The author referred mainly to the operation of steam hammers by steam, electricity and compressed air.

Given fairly cheap power for compressor driving, he said, compressed air hammers, properly designed for the purpose, afforded a palpable advance on ordinary steam hammer practice. In any but the very smallest installations, the matter of air compressing, storage, and distributing plant warranted most careful attention. One point well known in theory, but very often ignored in practice was that air compressors should be supplied with cool, clean air as dry as possible. After compression, the heated air should be cooled or allowed to cool before it passed into the air mains; otherwise cooling in the mains would entail deposition of moisture which gradually collected and was driven forward with grit and rust, finally causing trouble in the working parts of the apparatus with which it came in contact.

Installation Features.

Compressed air could be conveyed through pipes for a long distance with practically no loss, especially where the demand was intermittent, and where a supplementary air receiver was placed at or near the end of the air main, remote from the compressor. In large installations, the air compressors required large units of power to drive them, and it was good practice to couple them as directly as possible with the prime movers, with consequent improvement in capital costs and power transmission efficiencies. As a definite example, a compressor requiring 100 h.p. to drive it might be considered. The ideal arrangement would comprise a prime mover capable of driving this compressor and direct coupled to it. On the other hand, where there existed an electric power generating station, the tendency was to place the air compressor near the department where the compressed air was required and to transmit power to it electrically. Under such conditions, the sequence of plant would probably be as follows:

Prime mover, electricity generator, switches and instruments, transmission cables, motor and starter, and power transmission to compressor crank shaft. Each conversion of energy entailed a serious loss, and instead of a transmission efficiency of 95 per cent. with the simple arrangement, probably less than 75 per cent. efficiency would be obtained under the electric transmission arrangement, while there would be a much in-

creased capital expenditure on account of generator, instruments and switch gear, cables, motor, and a necessarily large prime mover.

Air Leakage.

It was sometimes advanced, as an objection to compressed air as a power transmitting agent, that leakage was liable to be a great and unknown quantity. The uncertainty as to the rate of consumption of compressed air by the various items of apparatus to which it was supplied and the continuance of the good efficiency of the air compressors had always been a cause of uneasiness to the engineers responsible for the good working of an installation of any considerable magnitude. To meet the requirements of the case, the author had designed a combination of variable orifice and manometer. The variable orifice was in the form of an accurately constructed sluice valve, and the manometer, which was not provided with any scale, simply indicated with great certainty and precision one particular pressure difference which might be caused by more or less closing the valve to the flow of air. The valve, which could serve as an ordinary stop valve, was inserted in the pipe line, and was fitted with a scale to indicate the precise amount of opening, and, consequently, the precise amount of throttling of the flow, which produced that one pressure difference under which the manometer was operative.

TOOL-MAKERS HOLD A BANQUET.

THE Canadian Westinghouse Co. tool room employees held their first annual banquet, on Friday evening, Feb. 22, at the Germania Hotel. For a first attempt, the affair was in every way a success. After dinner, Mr. F. Fennel, the chairman, called for a toast to the King, after which J. Newlands and W. S. Barnes, on behalf of the committee, made Mr. Fennel a present of a very handsome posy, to which he responded in a very appropriate manner.

In response to the toast of the Tool Department, Mr. A. Stone said that tool-making was one of the oldest of trades or occupations. Some nations even to-day were using the same kind of tools or implements used by their ancestors some forty centuries ago. The last century had proved the banner century in inventions of all kinds, and George Westinghouse and Thomas Edison ranked in the first class of this feature.

ROAD-MAKING MACHINERY.

THE annual Convention of the Ontario Good Roads Association was held last week, in the Dairy Building, Exhibition Park, Toronto. Among the various exhibits were all manner of ma-

terials for road construction, including those Macadam, asphalt, and concrete roads, while road beds of many kinds were also shown. A feature of especial interest was the new trap rock for surface work. This is a product of Northern Ontario, and has only recently been placed upon the market. Other exhibits were paints for concrete bridge work, steel culverts, and reinforced steel for concrete roads.

Among the construction machinery shown were various types of steam rollers, and one of the latest steel drags, which is the first of its kind to be introduced in Canada. Several American firms exhibited, and it is stated that this is the first time that the manufacturers of the United States have made a bid for Canadian trade in road construction work.

STRIKES IN 1912.

THE loss in working days from strikes in 1912, according to the Department of Labor's record, was only about half the similar loss in 1911, though amounting to over one million days. This covers the whole of the Dominion. There were a large number of strikes, but the great majority were short and involved only a small number of men. Altogether 40,500 employees went out on strike in 1912. The Industrial Disputes Investigation Act applies only to disputes in industries involving public utilities, and practically all the above mentioned disturbances were outside its jurisdiction. Altogether about nineteen threatened strikes were referred under the Act in 1912, settlements being thereby effected in all but three cases.

BRICK PLANT FOR BURLINGTON.

THE Excelsior Brick Co., Ltd., with head office at 84 Victoria St., are building a new plant at Burlington, Ont., and are purchasing all their plant from The American Clay Machinery Co., of Willoughby, Ohio. They are installing one No. 233 auger machine of capacity, 5,000 bricks per hour, with a standard eagle re-press and interchangeable mold boxes. The arrangement of the plant is such that the shale will be loaded on cars in the shale pit, and drawn into the building with a winding drum. The material will then be delivered to two 9 feet dry pans, and from the dry pans will be delivered by an elevator to the piano wire screens. The screened material will pass on to a conveyor, which delivers into a feeding bin above the disc feeder attached to the pugmill. The whole plant will be operated by one 200 h.p., two 40 h.p., and one 15 h.p., 3-phase, 25 cycle, 550 volt Westinghouse motors.

FOUNDRY PRACTICE AND EQUIPMENT

Practical Articles for Canadian Foundrymen and Pattern Makers, and News of Foundrymen's and Allied Associations. Contributions Invited.

LOAM PATTERN AND MOULD FOR SPIRAL DRUM.

By Joseph Horner.

CRANE drums or barrels are universally made with spiral grooves, except in the very small sizes. The grooves guide the chain or rope, and prevent overiding. The sectional forms of the grooves vary, being shaped differently for chains and ropes. The drums are made in all diameters from about 18 in. to 15 feet. The smaller sizes up to 3 feet or 4 feet in diameter are moulded from patterns, usually made in loam, because the numbers of drums required alike are not generally sufficient to justify the cost of a wooden pattern. If over about 4 feet in diameter they are swept-up in loam moulds, the axis of the drum being set vertically. We illustrate the first method of manufacture, selecting a drum for wire rope, Fig. 1,

The first stage of the striking up is seen in Fig. 2, representing that at which the plain foundation or body of the loam pattern has been swept up in readiness to receive the spirals. It would be impracticable to strike these and the ends of the pattern simultane-

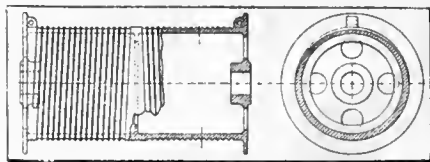

Fig. 1. Moulding a Spiral Drum.

ously, hence, in the first stage, the ends are swept up, and also a body, which, apart from the ends, has no correspondence with the finished pattern and casting, except in so far as it serves as a basis for the spirals. It bears, as regards its diameter, an approximate pro-

Fig. 2 indicates how the pattern body is constructed, being similar to a core. An ordinary core bar (F) of convenient size is taken, and plates (G), (G), (G), (G), about 3-8 inch thick and cast with numerous holes to facilitate breaking up, are wedged on the bar. Four long bolts (C), pass through these plates and retain the end ones from movement. These bolts are inserted after the hay ropes have been wound as far as the radius at which the bolts are inserted. Coarse loam is worked between the hay ropes as the winding proceeds.

Fig. 3 shows the two spirals, the right and left hand being swept up by the board (II) controlled by the templet (L). The templet is shown enlarged in Fig. 4. It is a block of wood turned with the end grain running axially, and of any suitable size, say from 8 inches to 12 inches diameter and 3 inches or 4 inches

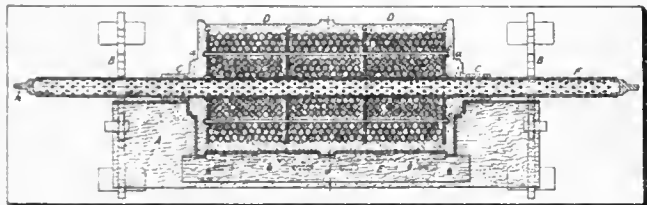

Fig. 2. Moulding a Spiral Drum.

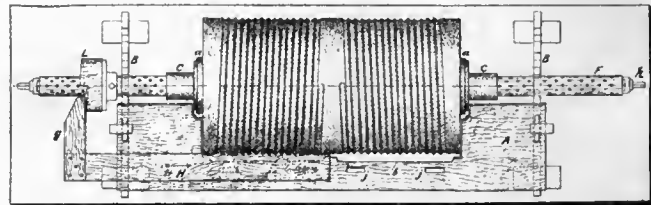

Fig. 3. Moulding a Spiral Drum.

which has right and left hand spirals to lead two ropes off in unison from the ends to the centre, the rope being anchored in the lugs. Holes are cast in the ends of the drum through which the bolts holding the core plates in position are withdrawn, and through which also the core plates are broken up and removed, along with the hay ropes and sand of the core.

portion to their diameter, being a little smaller, to afford a body of loam at the bottom of the spiral grooves.

The board (A), seen in Fig. 2, resting on the core trestles (B), (B), sweeps up the end bosses, and core prints (C), (C), and the shoulders (a), (a), for the flanges (which are of wood, as is usual in loam work) and portions of the drum body corresponding with ends and centre—see Fig. 1. The recessed portions (D), (D), which are to receive the spirals later, are swept with a separate board (E.) This board must be separate from the lower one (A), which strikes the portions previously named—bosses, prints, flange seatings, and plain body. The board (A) is cut back to clear the body as seen at (b). When the board E is removed, the boards for the spirals are substituted. The body must be dried in the stove before this is done, otherwise the spirals would sag out of circular form. Before the spirals are swept, the board (A) is withdrawn backwards, away from the portions already swept up, see Figs. 2 and 3.

thick, bored to fit freely over the striking bar (F). The spiral is indicated by a slip of paper, Fig. 5, of length equal to the circumference of the block, and having one edge (d) cut to the angle of the thread; i.e., the difference in the lengths (e) and (f) is exactly the same as the pitch of the spiral. The paper is glued round the block, as seen to the left of

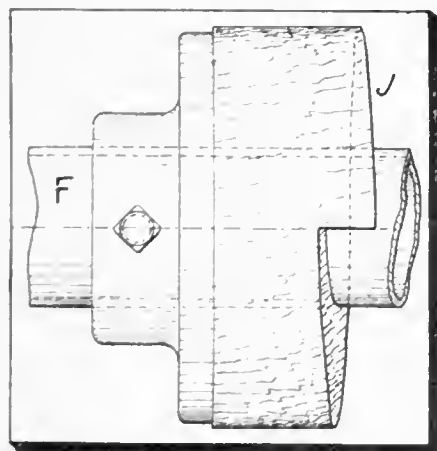

Fig. 4. Moulding a Spiral Drum.

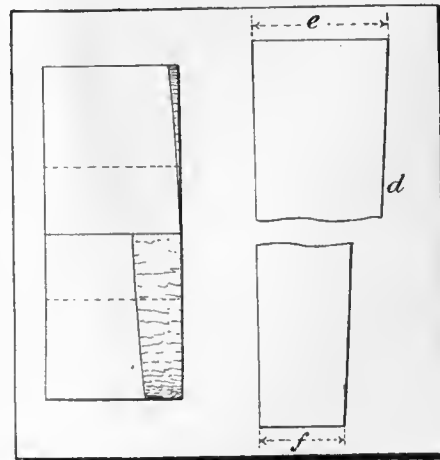

Fig. 5. Moulding a Spiral Drum.

Fig. 5, and is a guide by which the face is cut with gouge, chisel and narrow plane. The faces are cut radially in exactly parallel lines with the back of the block. The face is well oiled. An iron face-plate is screwed on the back. Fig. (3), and has a clamping screw by which it is pinched on the bar. A few thin wedges are driven in from the front to keep it steady.

As this templet screw is cut to the pitch, and the board (H) has its working edge cut to the section of the grooves of the spiral, it follows that one traverse of the board in the direction of the arrow, controlled by holding the piece (g) against the templet screw, will sweep up the whole of the spiral grooves for that

surface. A coat or two of shellac varnish may be added. From a dozen to twenty moulds may be taken from such a pattern. The flanges are turned in wood to fit over the shoulders (a), (a), resting against the ends of the loam body, and the two lugs for the attachment of the rope, see Fig. 1, are also made in wood and fastened to the flanges, thus completing the pattern.

The core is swept up as shown by Fig. 6; (M) being the striking board. The bar has sundry plates (N) wedged upon it of about 3/8-inch thickness. These are cast with holes to facilitate breaking up, and tied together with bolts (k). The end plates have rods standing out to carry the loam around the internal

NOVA SCOTIA STEEL & COAL CO.

IN the annual report of the directors of the Nova Scotia Steel and Coal Co., to which reference was made in a previous issue, Mr. R. E. Harris, K.C., the president says:—

The amount expended during the year on Capital Account was \$1,279,569,000, which amount (less the sum of \$98,241.81, the original cost of the steamship Wobun, and some small sales) had been added to the Property and Mines Account. Owing to the depressed state of the iron and steel trade in the United States and the coal strike in Great Britain, low prices for iron ore prevailed during the early part of the year, and the directors therefore decided that it

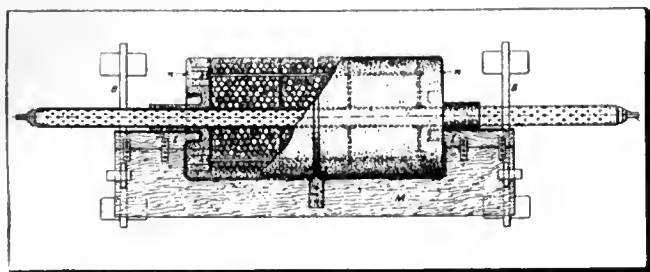

Fig. 6. Moulding a Spiral Drum.

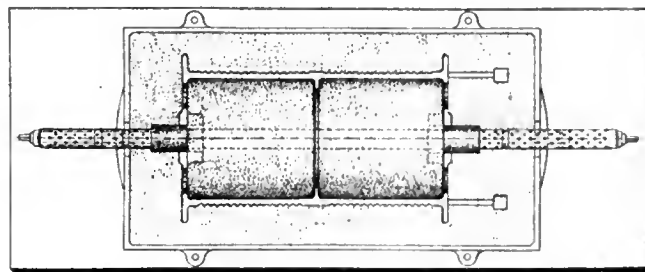

Fig. 7. Moulding a Spiral Drum.

half of the drum. One traverse will not suffice to make a clean screw; a dozen or twenty will be required, with coarse loam first and fine loam for finishing, because the summits of the spirals are rather fragile and are not easily finished smoothly. The operation is as follows:

A boy turns slowly and carefully the core bar with handle on end (h). The coremaker presses the contact piece (g) at the end of the board (H) against the face of the templet screw during the rotation of the work. When one revolution has been completed, the boy pauses for a moment while the coremaker slides back the board to the highest part of the templet screw (L), ready to take another traverse as the boy gives another turn. When the board is slid back, it unavoidably leaves a groove along the loam equal in width to the thickness of the board. This is of no consequence as the space is filled up with loam, after the last movement, and when dried, it is concealed and finished by the aid of a templet. The rectilinear motion is ensured by the slots, into which the studs fit. The slots and studs may be in either board.

The board (H) is now removed, and a similar board for the other half set in place. Another templet screw of the opposite hand is fitted on the bar, and the sweeping up proceeds precisely as in the first operation, completing the spirals. The pattern is then put into the stove and dried. When taken out, the grooves are smoothed with glass-paper, and the surface is given a coat of tar, which when dried leaves a hard

end bosses beyond the reach of the hay ropes. These bosses are struck by tongue pieces (l) screwed on the board (M), for removal after the core is finished, to permit board (M) to be drawn backwards. The internal stiffening rib is struck in the core by the tongue piece (m). The sweeping of the core is first done with coarse loam worked among and over the bay ropes, and allowed when nearly up to finished size to remain a few hours to stiffen. The final coat of finely sifted loam is worked over, swept neatly and finished, and the core put in the stove to dry. Afterwards it is blackened with wet blacking. The round holes cast in the ends, as seen in Fig. 1, are formed by nailing round cores on the end of the main core on a circle struck round from a line marked at (n), Fig. 6. These cores are seen in Fig. 7.

Moulding is done in a two-part box by turning over. It is plain, straightforward work, the details of which need not be described. Fig. 7 is a plan view of the bottom box as it appears when cored up ready for being closed and poured. It is poured at one end (the right hand, Fig. 7), through two ingates supplied from one basin, and the metal runs along directly between the mould and core. At the opposite end, though it cannot be indicated in a joint section, there is a flow-off basin. These moulds are usually made in a dry sand mixture, especially when they are of large dimensions. The smaller moulds are frequently made in green sand.

would be more profitable to carry over a portion of the output. This ore, together with our full output for 1913, has since been sold at an advanced price.

With the increased revenue, which we expect to receive from the larger sale of ore, the higher prices being received for our other products and with the earnings from new plant installed during the past few years, much of which is only now becoming productive, your directors are of the opinion that the year 1913 will give a considerable increase in earnings over any previous year.

—♦—
THE CANADIAN MACHINERY MARKET.

WE understand that the Machinery Users' Association of Great Britain has decided to appoint a committee of inquiry to visit Canada this year with a view to investigating the facilities which Canada offers for the establishment of industrial undertakings, and as to the best method of promoting a closer relationship between the industrial and commercial interests of Canada and the United Kingdom, and to report thereon to the members of the association. There can be no manner of doubt that this departure is a step in the right direction, for the extraordinary development which has taken place in the industries of the Dominion of Canada during the last few years has shown what a wonderful field it offers for the labor and capital of the Mother Country.

The MacLean Pub. Co., Ltd.

(ESTABLISHED 1888.)

JOHN BAYNE MACLEAN - - - - - President
H. T. HUNTER - - - - - General Manager
PUBLISHERS OF

CANADIAN MACHINERY AND MANUFACTURING NEWS

A weekly newspaper devoted to machinery and manufacturing interests, mechanical and electrical trades, the foundry, technical progress, construction and improvement.

H. V. TURRELL - - - - - Business Manager

PETER BAIN, M.E. - - - - - Editor
J. H. WILLIAMS - - - - - Associate Editor

OFFICES:

CANADA

Montreal, Rooms 701-702 Eastern Townships Bank Bldg.

Toronto, 143-149 University Ave., Phone Main 7324

Winnipeg, 34 Royal Bank Bldg., Phone Garry 2313

Vancouver, H. Hodgson 2649 Third Ave. West.

GREAT BRITAIN

London, 88 Fleet Street, E.C. Phone Central 12960
E. J. Dodd

UNITED STATES

New York, R. B. Huettli 115 Broadway, New York, N.Y., Phone 2209 Rector

Chicago, A. H. Byrne Room 607, Marquette Bldg. 140 S. Dearborn St., Chicago

CABLE ADDRESS:

Macpubco, Toronto. Atabek, London, Eng.

SUBSCRIPTION RATE:

Canada, \$2.00; United States, \$2.50; Great Britain, Australia and other colonies, 8s. 6d. per year; other countries, \$3.00. Advertising rates on request.

Subscribers who are not receiving their paper regularly will confer a favor on us by letting us know. We should be notified at once of any change in address, giving both old and new.

Vol. IX. MARCH 6, 1913 No. 7

PRINCIPAL CONTENTS.

The New Era in Machine Tool Design	225-228
Preparing Parts to be Ground	228-229
Shipbuilding, Shipping and Marine Engineering	229-230
Cammell, Laird & Co., re Shipyard at St. John, N.B. Fort Nelson or Fort Churchill...New Shipyard for Canada...Shipbuilding at Levis, P.Q....To Anclon Lake Steamers.	
The Future Prime Mover-Turbine or Motor	231-232
Steel Works in the Orient	232
Canadian Railroad Extensions and Betterments	232-233
G.T.R. Shops for Prescott, Ont....Track Laying on G.T.P. and N.T.R....Canadian Metallurgical Laboratory Hamilton's Industrial Prosperity...Canadian Locomotive Co....Electric Railways in Canada.	
General	234
Bonuses for New Industries...New Industry for Welland...Waterworks Inefficiency.	
Machine Shop Methods and Devices	235-236
Drill Drift Connection...Drill Jig for Connecting Rod Bearings...A Shaper Kink...Screwing Fixture for Lathe...Proportional Reduction of Volume...Handy Shop Tools...A Piston Ring Testing Machine.	
Developments in Machinery	237-238
New Westinghouse Motor...Motor Driven Geared Head Lathe...Motor Driven Disc Grinder...A Uni- versal Miller.	
General	238-239
C. S. Steel, Toronto...Compressed Air and Its Measurement...Toolmakers Hold Banquet...Strikes in 1912...Brick Plant for Burlington...Road-Making Machinery.	
Foundry Practice and Equipment	240-241
Loam Pattern and Mold for Spiral Drums...Nova Scotia Steel and Coal Co....The Canadian Machinery Market.	
Editorial	242
Industrial and Construction News	243-249
Engineering...Electrical...General Industrial... Municipal...Railways...Bridges...Water Works ...Wood Working...Building Notes...Marine... Tenders...Contracts Awarded...Personal...Obituary ...Trade Gossip...Catalogues...New Incorporations.	
General Market Conditions and Tendencies	250
New Plant at Peterborough	250
Selected Market Quotations	251-252
General	252
Trade with Britain...Mr. Plummer Optimalistic... Dominion Steel Corporation.	

MACHINE TOOL DESIGN.

OUR leading article in the present number is entitled the "New Era in Machine Tool Design—Its Requirements," and if its contents indicate anything, they surely bring home forcibly to users and operators of machine tools, the fact that makers of these commodities are fully alive to the necessities of the age and that while admitting their present shortcomings in achieving the ideal aimed at, are not slow to express their opinion as to being able in the near future to compass the situation. There is little of the fanciful and much of the utilitarian 20th century spirit pervading the whole paper, and while it may be somewhat invidious of us to single out any particular features of the contents, believing that our readers are themselves capable of the necessary discernment, we shall, perhaps, be forgiven making references to a few points of more or less outstanding importance.

Considerable prominence is given by the writer of the paper, to the fact that guesswork in machine tool design and construction has been practically eliminated. The necessities of our time have made the demand that, for a particular purpose, a particular denomination and quality of material shall be furnished, with the result as stated, that we have got away from the purchase of iron or steel, in a general way, and specify instead, exactly what nature of either we want. As it is aptly remarked, we have got away from the idea that brass or bronze, because it happens to be more or less yellow, is suitable to our purpose.

Reference is made to the demand for better conditions for the operator, and who shall say that this is not one of the very fundamentals on which both quality and quantity output are based.

The feature of the paper which may appeal more forcibly than any to both user and operator is perhaps that referring to the "power operation of heavy parts." It indicates that sinew and muscle are of secondary importance and strikes a responsive chord in the combination of effort towards a highly productive efficiency, and indicates at the same time the insight and intelligence being displayed to secure at one stroke, as it were, a satisfied employer and employee, owning and operating a high grade up-to-date tool. The recognition of the operator as an intelligent being, and the provision made whereby that intelligence is given scope for display is merely an advance accomplished that none of us would wish to see retrograded. The fact that a man can, with the minimum of bodily exertion, manipulate his machine and its content, and devote, as a consequence, without irritation and discomfort, his brain energies to actual productive work, is a marked achievement in machine tool design and equipment.

The paper is full of encouragement for the future of the industry, and while primarily, perhaps, of direct interest to the user and operator, it contains a plain unvarnished intimation to machine tool manufacturers generally, that, if they would stay in the field, their product in its essence and nature must conform to the full with present day requirements.



TORONTO'S NEW TECHNICAL SCHOOL.

IN a previous issue, reference was made to the subject of technical education in Toronto, and to the school which it is proposed to erect for that purpose. The "big eyes" feature and "swelled head" idea seem to be more predominant than brains and common sense in the persons of those engineering the project, and as a consequence there is an enormous shortage of cash to carry out the undertaking.

INDUSTRIAL ^A_N^D CONSTRUCTION NEWS

Establishment or Enlargement of Factories, Mills, Power Plants, Etc.; Construction of Railways, Bridges, Etc.; Municipal Undertakings; Mining News.

Engineering

Sarnia, Ont.—It is rumored that the Solway Process Company, of Detroit, will locate here.

Napanee, Ont.—W. H. Harvey has been granted the contract to build a boiler shop for the Napanee Iron Works, Limited. The machinery has been ordered.

McAdam Junction, N.B.—The C. P. R. will build a machine shop of concrete, tenders for which are being called. Wm. Townie, general superintendent, St. John, N.B.

St. John's, Que.—The Canada Grip Nut Co., Ltd., head office in Montreal, have established a factory in St. John's, which will soon have a capacity of 75,000 nuts per day.

Montreal, Que.—A factory to cost \$250,000, at Ville la Salle, is planned for the Canadian Fairbanks-Morse Co., 444 St. James Street. Engineers, T. Pringle & Sons, Ltd., 419 Coristine Bldg.

Pembroke, Ont.—The plants of the Electric Company of Canada, Ltd., and of the Steel Equipment Co., Ltd., will be established in Pembroke if the rate-payers grant the concessions asked.

Belleville, Ont.—The Steel Company of Canada is about to make large additions to its works here. A siding from the Canadian Northern Ontario tracks will be run into the rolling plant, five feet west of the present G. T. R. spur into the works.

Hamilton, Ont.—The Board of Control have decided to divide the \$50,000 meter contract amongst the following three companies: Canadian Westinghouse, Canadian General Electric, and the Chamberlain-Hookham Company. The Westinghouse Company secured the transformer contract at \$30,000.

New Westminster, B.C.—The Imperial Car Mfg. Co., of Pittsburgh, have secured a large site in Port Mann, and will erect a plant on it, with an initial capacity of ten steel freight cars per day. It is stated that this concern has a contract with the C. N. R. for 5,000 freight cars, to be built in five years.

Hamilton, Ont.—The negotiations which have been in progress for some time for the amalgamation of the Dominion Steel Castings Co., Ltd., and the

Hamilton Malleable Iron Co., Ltd., it is expected, will be closed in the near future. It is said a holding company will be formed with a capital of \$3,000,000, and that the merger will employ between 500 and 700 people.

Montreal, Que.—It has been announced that Sir William Arrol & Co., Ltd., of Dalnarnock Works, Glasgow, the designers and constructors of the buildings for the Canadian Vickers Co. at Montreal, are arranging to establish construction works here, for the production of all kinds of cranes; presses and other machinery, and to otherwise extend their operations in Canada.

Edmonton, Alta.—Property has recently been acquired by the Dickson Bridge Co. of Cambellford, Ont., who have arranged for the early installation of a

of Owen Sound. At a subsequent meeting the following officers were elected: J. J. Drew, president; G. B. Ryan, vice-president; Col. A. H. Maedonald, secretary-treasurer. The executive offices of the company will be located in Guelph, while the mills will be located in Owen Sound. The construction of these will be rushed.

St. John, N.B.—The buildings to be erected by J. McAvity & Sons are: Malleable iron foundry, including flask shed, union shops and core room; iron moulding shop, including emery wheel grinding room, tumbling and cleaning, coal and pig iron, flask and sand sheds and pattern vault; brass pattern vault, brass pattern shop, drafting room and timber sheds; building for hydrants, stand pipes and lamp posts; soil pipe warehouse, brass finishing shop, monitor room, brass moulding shop and flask sheds; polishing, plating, assembling rooms and warehouse; machine shops, testing and construction rooms; pipe sheds, pipe shops for cutting and threading, pipe bending and welding shops, blacksmith shop and power plant. The plant will employ 2,000 hands when completed.

CALL FOR NEW EQUIPMENT.

THE CANADA FOUNDRY CO., TORONTO, ONT., will shortly place orders for the supply of the undermentioned items of Machine Tool Equipment:

- One high speed planer.
- Two medium planers.
- Two shapers.
- One keyseater.
- One grinder.
- One slab miller.
- One vertical miller.
- One horizontal miller.
- One horizontal drill.
- Two radial drills.
- One sensitive high speed drill.
- Two small drills.

plant here. It has now been decided to make this more extensive than at first intended, in view of the extensive business in sight. The company expects to commence with a complement of about 200 men. Buildings to be erected will cover three acres and will have trackage through them.

Sarnia, Ont.—A report comes from Detroit that Charles M. Schwabb, head of the independent steel interests, is contemplating the erection of a Canadian branch of the Independent Steel Company to compete with the United States Steel Corporation at Sandwich, Ont. Steel men are inclined to believe that Schwabb really means business as regards the establishment of a Canadian branch. It is also said that Schwabb has a site in view at Point Edward.

Guelph, Ont.—At a meeting of the shareholders of the Owen Sound Rolling Mills Co., the following directors were elected:—J. J. Drew, G. B. Ryan, Col. A. H. Maedonald, Frank V. Samwell, all of Guelph, and W. S. Middlebro, M.P.,

Electrical

Oxbow, Sask.—A civic electric lighting plant, to cost \$12,000, is contemplated.

Truscon, Man.—New street lights will be purchased by the City Council of 500 and 100 candle-power.

Galt, Ont.—There is a big demand here for electrical power. Forty new services have been installed during the year.

Glencoe, Ont.—An Hydro-Electric system is planned, power to be taken from the Hydro-Electric Commission of Ontario.

Brandon, Man.—Industries were at a standstill recently on account of generator in the Brandon Electric Light Co. plant breaking down.

Vancouver, B.C.—The Cariboo Power Co., Ltd., was recently incorporated with a capital of \$250,000, and head offices at Vancouver, B.C.

Guelph, Ont.—It is the general opinion that new street cars will be required during the coming summer, and a by-law

may be submitted for authority to raise funds.

Toronto, Ont.—The Hydro-Electric Commission will erect a large transformer on the Weston Road, near the Russell Motor Car Works.

Cedar Rapids P. & Mfg. Co.—The annual meeting of the Cedar Rapids Power and Manufacturing Co. was held on Thursday, March 6th.

Elmira, Ont.—The town has arranged with the Hydro-Electric Commission for 200 h.p., and will take over the Elmira Electric Plant at a valuation of \$3,000.

Swift Current, Sask.—Additions to power house to develop 200 horse-power are reported to be planned. A by-law will be submitted about March 15.

New Westminster, B.C.—The Western Canada Power Co. is supplying Milliardville with power and light, the lines for which are being laid. Milliardville is the new name for Fraser Mills.

Hamilton, Ont.—The Dominion Power and Transmission Company will build a large auxiliary steam plant in the north-eastern part of the city to provide power in the event of trouble through frazil ice at Deen Falls.

St. John, N.B.—The International St. John River Commission discussed, recently, the erection of a large dam for the generation of electric power by the St. John Hydro-Electric Co.

Welland, Ont.—The Welland County Independent Telephone Co. will remove their Fort Erie exchange to Bridgeburg when the new building is ready. The two exchanges will be consolidated.

London, Ont.—The Hydro-Electric Commission, H. J. Glabitz, engineer, is preparing plans and specifications for the installation of new motors and compressors at pumping station No. 1.

London, Ont.—The Street Railway is having trouble with their generators. New machinery will be installed in a few weeks. Power is being sought elsewhere, and transformers will be required. C. B. King is the manager.

Saskatoon, Sask.—The city will expend \$100,000 in extensions to their new street railway system. It is expected that a new turbo-generator of 2,000 kw. capacity will be ordered, which will almost double the present capacity.

Hamilton, Ont.—Tenders will be called shortly for equipment for transformer station. The Board of Control have ordered new plans to be prepared for the electric pumping station. The building complete, with equipment, will cost \$70,000.

Strathmore, Alta.—A company is being formed under the name of the Strathmore Light and Power Co. to supply light to Strathmore. Power to the extent of 100 h.p. will be developed, and the fuel used will either be producer gas, kerosene or gasoline. A. W. Bowman is promoting the scheme.

General Industrial

North Edmonton, Alta.—Richard Moss has bought five acres and will establish there a pork-packing plant.

London, Ont.—J. Grant, industrial commissioner, is negotiating for the establishing of a carpet factory here.

Estevan, Sask.—The Estevan Creamery should be ready for operation in a week, the machinery having arrived.

Welland, Ont.—The carriage shop operated by E. F. Lambert was destroyed by fire on Thursday, February 27.

Edmonton, Alta.—The Western Canada Flour Mills Co., Ltd., Winnipeg, has bought a site here, presumably for a plant.

Hamilton, Ont.—Hausplant Bros. are establishing a small plant at Port Arthur Ont., for the manufacture of art metal shades.

Radisson, Sask.—The Radisson Flour Milling Co. has been organized and a small flour mill and elevator will be erected.

Toronto, Ont.—An order has been issued winding up the Canadian Cereal and Milling Co., Ltd., Wm. Carswell is interim liquidator.

Welland, Ont.—A by-law will be presented to the electors of Ridgemount and Niagara Junction to permit capitalists to start a quarry there.

Pembroke, Ont.—The box factory of the Canada Spooke Mills will be in operation this month. Machinery and a boiler have been installed.

Preston, Ont.—Woollen mill machinery from England will be installed at the Patterson Woollen Mills this week. The consignment includes eight looms.

Cambellford, Ont.—The loss by fire on the building of the Corundum Mill at Craigmount, was \$250,000. The Canada Corundum Co. owned the property.

Winnipeg, Man.—Work has commenced on the new factory of Stuart, Woods, Ltd., to cost \$200,000. The Archibald Engineering Co. are the contractors.

Ottawa, Ont.—The Cowie Building, worth \$30,000, was destroyed by fire on Tuesday last. A loss of \$50,000 was

sustained by the Lowe-Martin Printing Co. and the Electric Bean Chemical Co.

Winnipeg, Man.—The Scottish Co-operative Society, of which George Fisher is the Winnipeg manager, contemplates building a number of grain elevators in western Canada this year.

Simcoe, Ont.—Dominion Cannery, Ltd., have completed a building for the printing and lithographing department, and new presses are being installed. Several other new buildings are being added.

Swift Current, Sask.—W. G. Orcutt, the representative of the Unit Brick Co., a concern recently established in Regina, has approached the Board of Trade with a proposition to build a plant here.

Port Dalhousie, Ont.—Tenders were opened on March 1 for the erection of a three-storey concrete canning factory, for the Port Dalhousie Canning Co. Watt & Blackwell, Hamilton, Ont., are architects.

Bridgeburg, Ont.—The Tuttle & Bailey Mfg. Co., New York, N.Y., makers of registers, plan the establishment of a Canadian branch here. It will be composed of five tributary plants, and cost about \$60,000.

Winnipeg, Man.—The Manitoba Gypsum Co., Winnipeg, has taken over extensive gypsum deposits at Falkland, near Kamloops, B.C., and will erect a plant there that will give employment to more than 100 men.

London, Ont.—The City Gas Company, J. C. Duffield, manager, will enlarge its plant and distributing system and install new equipment. The approximate expenditure for the extensions and improvements will be \$100,000.

Marlboro, Alta.—The Edmonton Portland Cement Co. has about four-fifths of the work of constructing its plant completed. The capacity of the plant is to be 1,500 barrels per day. It will be in operation in two months.

Guelph, Ont.—A factory employing 75 persons at the start will be erected by the Canadian Flax Mills, Limited, capitalized at \$1,000,000. There will be three buildings, the main one being 80 by 120 feet of three storeys. There will also be a power house.

St. Catharines, Ont.—The citizens have ratified by-laws to make concessions to the B. F. Gooderich Company, of Akron, Ohio, manufacturers of tires and other rubber goods, to W. H. Briggs, of Hamilton, for the erection of a jam factory. The Gooderich plant will employ 1,000 hands.

Joliette, Que.—Biscuit factory owned by Joseph Dufresne has been burned. Loss \$50,000.

Warton, Ont.—Moore's Novelty Works was burned recently, the machinery being damaged.

Sarnia, Ont.—An ice plant will be built on the site of the Longhead Hub & Spoke Works, which was destroyed by fire some months ago.

Hamilton, Ont.—A candy factory will be built in the East end, for Robert Hyslop, 151 King St. East. Architect, Stewart McPhie, Hamilton.

Toronto, Ont.—A factory to cost \$10,000, for the Eastern Rubber Co., Eastern Ave. will be built shortly. Architects, Chadwick & Beckett, 18 Toronto St.

Waterloo, Ont.—Damage to the extent of \$4,500 was done to the tannery and upholstering factory of the Spanish Leather Company, on Sunday, March 2.

Oxbow, Sask.—The Bow City Creamery Co., Ltd., contemplate erecting up-to-date creamery this spring, to be operated under Government supervision, and to cost \$6,000.

Toronto, Ont.—A factory will be built on Beverley Street for the National Drug Co., 27 Wellington Street. Manager, T. A. Henderson. Architects, Prack & Perrine, Hamilton.

Widdifield Station, Ont.—An explosive manufacturing plant is planned for the Energite Explosive Co., 506 Power Bldg., Montreal. Managing director, Lionel Kent, Montreal.

Merriton, Ont.—The sulphite department of the Riordan Paper Mills was destroyed by fire with a loss of \$50,000 on Sunday night, March 2. The paper machinery was not damaged. The insurance covers the loss.

Toronto, Ont.—The P. Lyall Construction Co. have 300 men working on the erection of steel work for the machinery building, three big kilns, and a gas production plant for the Ontario National Brick Company, Ltd., at Cooksville, Ont.

Peterborough, Ont.—A warehouse and factory will be added to the plant of the DeLaval Dairy Supply Co., each measuring 200 x 112 feet. The J. W. Ferguson Construction Company, of Patterson, N.J., have the contract. Mr. Leitch is the firms construction engineer.

Nelson, B.C.—The Kootenay Fruit Growers' Union will erect jam factories at Brilliant and Grand Forks. Ald. Jas. Johnstone, of Nelson and Major Goode, of Bonnington are members. An offer to sell the Kootenay-Columbia Jam Factory was refused by the Union.

Lethbridge, Alta.—The Lethbridge Brewing and Malting Co. will build a \$75,000, five-storey, addition to their plant this year, and in 1914 will erect a \$300,000 malting house, capable of handling 500,000 bushels of barley, and a \$250,000 bushel elevator, costing \$75,000.

St. John, N.B.—The Standard Clay Products, Ltd., will build a new plant at New Glasgow, N.S. W. C. Trotter, St. John's, P.Q., is president. This company was formed for the purpose of taking over the old Standard Drain Pipe Co., of St. John's, P.Q., which was unable to supply the demand.

Victoria, B.C.—A plant costing \$37,000, with a capacity of 90,000 bricks per day will be erected at Tyee Siding, B.C., by the Tyee Shale Products Co., Ltd. Open stove kilns will be used to be followed by down draught kilns later. Construction work will start at once, and the first bricks will be made in about four months.

Peterborough, Ont.—The binder twine machinery of the local branch of the International Harvester Co.'s plant is to be shipped to Croix, France, for operation there. Mr. C. C. Miller, who has been in charge of the local plant for the past two months will be the superintendent, and the heads of the various departments of the local plant will be transferred to France. The International Harvester Co. have been operating here for fourteen months.

Nanaimo, B.C.—The Ratepayers Association wish the removal of the Hamilton Powder Works from Departure Bay.

St. John, N.B.—The Maritime Oil Fields, Limited, a company controlled by English capital, took 101,430 gallons of crude oil, for which they find a ready market, from their wells in Albert County, N.B., last year. The company has spent nearly a quarter of a million dollars in development work. The natural gas from the same district, which has already been piped to Moncton and Hillsboro, will probably be piped this year to Dorchester, Sackville and Amherst.

Municipal

Weyburn, Sask.—\$20,000 will be spent this year on sewers, waterworks and paving.

Welland, Ont.—The City Council wishes to purchase a road scraper for \$360, and four dump wagons at \$160 each. They will also purchase a tractor.

Calgary, Alta.—The city is asking the Western Canadian Natural Gas, Light, Heat and Power Co. for cheaper gas. Failing this, the city will install a municipal plant.

Winnipeg, Man.—Eastern capitalists have offered the City Council natural gas at 30c per 1,000 ft. for domestic use, 20c for gas engines and 15c for manufacturing. The present price for domestic gas is \$1.35 per 1,000 ft.

Lethbridge, Alta.—R. A. Ross, a Montreal power expert, says that power can be produced here from the coal and gas fields for \$15 per h.p. per annum.

Edmonton, Alta.—The city will spend \$60,000 this year on a plant for making bitulithic pavement.

Victoria, B.C.—The Council of South Saanich, B.C., have accepted an invitation from this city to send a deputation to attend a conference between representatives of Victoria, Esquimalt and Oak Bay for the discussion of all matters relating to sewerage, water supply, electric lighting, and so forth, in which they were jointly interested.

Railways - Bridges

Ottawa, Ont.—The Government has no intention of taking over the Quebec and Saguenay Railway.

Nelson, B.C.—The C.P.R. will standardize the line between Kaslo and Slocan, B.C., heavy steel rails being used.

Moose Jaw, Sask.—The C.P.R. will spend about a million dollars here on new shops, yards and depot, and new trackage.

Ottawa, Ont.—The Central Railway Bill for construction of a line from Montreal to Midland, Ont., was killed in committee.

Hamilton, Ont.—George F. Webb has filed plans for an incline railway at Wentworth St., grade 35 in 100, for street cars, etc.

Windsor, Ont.—The Essex Terminal Railway have purchased land for better switching facilities to Sandwich, where the U.S. Steel Corporation plant will be located.

Humboldt, Sask.—The C.P.R. will construct a line from Lanigan to Prince Albert, through Humboldt. The C.N.R. will finish the line from Humboldt to Melfort this year.

Ottawa, Ont.—The C.N.R. line from Toronto to this city should be completed by July. Steel will be laid between Ottawa and Sydenham by the end of March. The rest of the steel is laid.

Vancouver, B.C.—Tenders are being called by the C.P.R. to close April 15, for the cutting of a tunnel 28,000 feet long through the Rogers Pass Hill. J.

G. Sullivan is chief engineer of western lines.

Vancouver, B.C.—The C. P. Rly. Co. have been authorized to construct a bridge over Kanaka Creek.

Port Arthur, Ont.—C. N. R. officials announce that this city will be linked up with Sudbury by rail in the fall.

St. Catharines, Ont.—On March 28 a by-law will be submitted calling for the raising of \$250,000 to cover the cost of building King street bridge.

Medonite, Ont.—The Canadian Pacific Railway Company has been authorized to construct a bridge on the Muskoka subdivision of its railway, near Eady, Ont.

Port Stanley, Ont.—At an early date a by-law may be submitted calling for the raising of \$10,000 to provide terminals for the London and Port Stanley Railway.

Toronto, Ont.—The Massey-Harris Co., Ltd., 915 King street west, have been authorized to construct a bridge over the G.T.R. at Stafford Street and Wellington avenue.

Windsor, Ont.—The consolidation of Sandwich and Windsor is suggested, and may take the form of a by-law. Railway and ferry facilities between the two towns will be improved.

Toronto, Ont.—The C. N. R. will enter this city on the east to reach its freight yards on Eastern Ave. from a point on the Toronto and Ottawa line, and will cross the Don by a bridge.

Fredericton, N.B.—It is understood that New York capitalists are interested in a proposition to provide Fredericton with a street railway. A company has been organized with a capital of \$250,000.

St. Boniface, Man.—The bridge over the Red River will cost \$600,000. It will be 930 feet long, with seven spans, consisting of two abutments and six piers. Navigation facilities will be provided in a Strauss bascule lift span.

Vancouver, B.C.—The tender of the J. McDiarmid Co., of Winnipeg, for the construction of the Harris-Georgia St. bridge was \$455,000 or \$3,000 more than that of Martin Carroll & Co., of Kansas City. The contract lies between these two.

St. John, N.B.—The St. John Suburban Railway Co. which proposes to run lines from St. John to Westfield, Spruce Lake, Rothesay and other points, will apply for incorporation. John R. Graham, and Henry W. Cushman, of Bangor, Me., and M. W. O'Doherty, C. F. Inches and D. K. Hazen of St. John are the incorporators.

Calgary, Alta.—The city have assured the Canadian Pacific Railway that they will be in a position to meet the demand for continuous supply of power of the amount required, and to give the maximum of 2,000 horse-power, called for in the present agreement of the city and the Canadian Pacific Railway, to supply the power for the company's shops at Ogden.

Ottawa, Ont.—The Minister of Railways has decided to build the round-houses, repair shops, machine shops and general terminals of the Hudson Bay Railway at Le Pas on the south side of the Saskatchewan. The line is being constructed eastward from Le Pas Mission to the Bay. The shops will be large enough to accommodate every variety of rolling stock. Plans are now being prepared for the yard which call for forty tracks, each capable of handling one hundred cars or four thousand cars in all.

Water-Works

Kincardine, Ont.—The town council contemplate the purchase of a water-works pump.

Fredericton, N.B.—Two fire stations, to cost \$30,000 are contemplated by the city council.

London, Ont.—The council has spent \$1,500 for property, on which it will erect a fire station.

St. John, N.B.—Legislation towards extending the water systems beyond the city limits is being sought.

Cowley, Alta.—A waterworks system is contemplated by the council, and a committee is looking into the matter.

Moose Jaw, Sask.—The following by-law will come up for consideration on March 13: To raise \$175,000 for extensions to waterworks system.

Vancouver, B.C.—The city needs a 12-in. water meter to measure water from the Esquimalt Water Works Co., capable of measuring 10,000,000 gallons per day.

Regina, Sask.—The ratepayers recently passed the following by-laws: \$825,000 for street railway extensions; \$675,000, electric light and power; \$200,000 for waterworks purposes.

Steeleton, Ont.—A waterworks system will be built to cost \$50,000. The work includes the laying of an intake pipe, erection of pumping station, machinery, etc. Town engineer, W. B. Redfern.

Ottawa, Ont.—The advice of British experts will be adopted, and about \$7,000,000 spent to bring water from the

Gatineau Lakes, by a route either forty or sixty miles long. It will take three years to complete. A chlorination plant on Lemieux island costing \$17,000 will be built.

Wood-Working

Preston, Ont.—Brick is arriving for an addition to the R. Forbes Furniture Factory.

Belleville, Ont.—The furniture factory of Tickell & Sons was damaged by fire on Sunday, March 2.

Hamilton, Ont.—Lumber mills to cost \$6,500, will be built at Mountain Top, for A. A. Lees, 47½ King street E.

St. Charles, Que.—Napoleon Labrie's sawmill was burned recently. The loss was \$12,000, partly covered by insurance. He will rebuild.

St. John, N.B.—A carriage factory, is to be built for Geo. Murphy, 648 Main street. The site has been purchased and plans will be prepared.

Red Deer, Alta.—Messrs. Baird and McKenzie, contractors, will construct a factory and planing mill adjoining the Great West Lumber Co.'s mill, measuring 40 x 80, and 18 ft. high. Steam Power will be used.

Building Notes

Toronto, Ont.—The Goodyear Tire and Rubber Co. will erect a six-storey office building costing \$80,000.

Edmonton, Alta.—The Edmonton Library Board have prepared plans for the erection of a library building to cost \$200,000.

Brantford, Ont.—The contract for the construction of the new post office has been let to P. H. Seord and Sons for \$200,000.

Regina, Sask.—The Sherwood Syndicate will erect a store worth \$425,000, measuring 100 x 125 feet, to be known as the Gordon-McKay store.

Winnipeg, Man.—The contract for the erection of the Prudential Trust building has been let to the George A. Fuller Co., and Ross and McDonald are architects.

Toronto, Ont.—A new edifice will be built for the members of Timothy Eaton Memorial Church, on St. Clair Ave., at a cost of \$115,000. Wickson & Gregg, architects.

Ottawa, Ont.—Plans are being prepared for a seven-storey building for the Ottawa Evening Journal. Construction

to start immediately. Arthur L Weeks, is the architect.

Battleford, Sask.—The Petrie Mfg. Co., makers of Magnet Cream Separators will build a warehouse here to supply Northern Saskatchewan. They have warehouses in Edmonton and Regina.

Montreal, Que.—The Canadian Metropolitan Realty Co. have purchased a building at the corner of St. James street and Place d'Armes, and will probably erect a ten-storey building on the site.

Calgary, Alta.—The Dominion Bridge Co., Ltd., have completed the erection of 730 tons of structural steel for the new Lancaster block. The Herald Publishing Co., Ltd., are erecting a 10-storey reinforced concrete building.

Toronto, Ont.—The city council have decided in favor of the twenty-storey 250 foot skyscraper at the north-east corner of King and Yonge streets which Messrs. J. & L. M. Wood propose to erect as an office building.

Moose Jaw, Sask.—The Ross Building Co. is planning a 4-storey apartment block to cost \$75,000. Bertrand & Chamberlain are architects. Construction work on the Citizens' Hotel will begin in May. Its cost will be \$1,000,000.

Shoal Lake, Man.—Tenders will be received up to April 1, for the construction of a brick and stone municipal hall. Hooper & Davis, Confederation Life Building, Winnipeg, are the architects, and F. Dobbs, village sec.-treas.

Toronto, Ont.—The Industrial Buildings, Ltd., will apply for a charter to form a company to build an 8-storey building, the floor space to be rented to small manufacturers. It will cost \$450,000. S. Makepeace, 212 Kent Bldg., is the architect.

Brandon, Man.—The Emerson-Brantingham Co., of Rockford, Ill., manufacturers of farming machinery in the United States, will establish here. They make a specialty of a plow engine, but build all kinds of agricultural machinery. It is expected they will later erect a substantial distributing warehouse.

Toronto, Ont.—The Engineers' Club of Toronto is considering a proposal to erect a ten-storey structure at the corner of Sheppard and Temperance streets, two or three floors to be devoted to club purposes, and the others to be rented to engineering firms.

Marine

Sarnia, Ont.—The Reid Wrecking Co. has not been purchased by the Great Lakes Towing Co., as reported.

Fort William, Ont.—The city may build an extra dock here, where boats may call and take on passengers.

St. John, N.B.—The Dominion Government contemplate the purchase of a 75 ton floating crane for St. John Harbor.

London, Ont.—The people will be asked to vote on the expenditure of \$75,000 to erect a breakwater, to protect west London from floods.

Owen Sound, Ont.—Local men will run a line of freight steamers to Fort William. Two boats will be bought by J. S. Robertson, one of those interested.

Ottawa, Ont.—The Pacific Dredging Company has been awarded the contract for dredging False Creek, Vancouver, B.C., at a price of approximately \$693,000.

Levis, Que.—T. Davie & Sons, are building six steel sews for the Dominion Public Works Department, and also a large hopper dredge for the Marine and Fisheries Department.

Vancouver, B.C.—The C.P.R. have given a contract for 250,000 feet of creosoted piling to the Pacific Lumber Creosote Plant at Eagle Harbor, Wash., to be used for dock extensions.

Montreal, Que.—The Canada Cement Company will build a 500 foot wharf at its plant at Pointe-Au-Trembles, for the purpose of facilitating the shipment of its product. The engineers employed by the Harbor Commission are now taking soundings, and it is expected that work will be completed by the fall.

Ottawa, Ont.—The Government will call tenders for the construction of ferry slips for the new car ferry service from Prince Edward Island to the mainland. The terminals will be at Cape Traverse and Cape Tormentine, and cost in the neighborhood of \$1,500,000 to \$2,000,000.

Hamilton, Ont.—Judgment has been awarded E. Browne & Son, wharfingers, Hamilton, against the Canadian Lake Transportation Co., of Toronto, on the former's counterclaim. The claim was for \$3,326 for alleged breach of a five-years' contract to bring 6,000 tons of freight yearly to the wharf to E. Browne & Son. A reference to the Master is directed to determine the amount.

NO ICE BREAKER FOR SYDNEY.

Some little time ago the Government decided to station an ice breaker at Halifax this winter instead of at St. John, as heretofore, in order that Sydney could have the ship when needed.

The Sydney Board of Trade took the matter up with the government, and received the reply that no boat was available, however, The Stanley has been stationed at Halifax, instead of St. John, so that she may go to Sydney when needed.

Tenders

Saskatoon, Sask.—Tenders will be called soon for the construction of a hospital 240 x 38 feet, five storeys. Light and power will be secured from the University building. Brown & Vallance, Montreal and Winnipeg, are the architects.

Toronto, Ont.—Tenders for sewage pumps with motors and automatic starting devices will be received by registered post only addressed to the Chairman of the Board of Control up to March 18. Specifications and tender forms may be had from the Sewer Section, Department of Works, Toronto.

Regina, Sask.—Tenders addressed to the City Commissioners, will be received up to March 29th, for the supply of: (1) Weatherproof copper wire, (2) Western cedar poles, (3) Cross-arms, (4) Top pins, Insulators, etc., (5) Pole line hardware, (6) Pole type transformers, (7) Integrating watt meters, single, poly-phase and two rate, (8) Metal flame arc lamps and station equipment, (9) Series cut-out mast arms for arc lights, (10) Underground material, (11) Fire alarm boxes and gongs. Price to be F. O. B. Regina. Copies of specifications may be had from E. W. Bull, superintendent of Light and Power, Regina, Sask.

Contracts Awarded

Hamilton, Ont.—Some of the contracts for the year's supplies are as follows: Small extension boxes, 2,500, \$1.38 each, Forwell Foundry Co.; large extension boxes, 500, \$1.48 each, Forwell Foundry Co.; brass supplies, valves, couplings, etc., Tallman Brass and Metal Co., \$8-123.05; 100 tons pig lead, \$4.24 per 100 pounds, Tallman Brass and Metal Company; 125 tons lead pipe, \$4.80 per 100 pounds, delivered at city yard, Canada Metal Co.; valve gates, \$1,555.02; gate valves, Darling Pump Manufacturing Co., \$1,345.80; cast-iron pipe, \$34.50 per ton, Gartshore Thomson Co.

Ottawa Ont.—Tenders for accessories to be used this year by the civic waterworks department were opened on Wednesday, Feb. 26, by the waterworks committee, when the following awards were recommended: Brass goods, the Robert Mitchell Co., Montreal, \$2,456.30; cast iron pipe, Canada Iron Corporation, Montreal, \$16,653.43; hydrants, Thomas Lawson & Sons, Ltd., Ottawa, \$49.75 each; lead pipe and pig lead, Capital Hardware Co., Ottawa, \$2,353.10; oils and grease Capital Warehousing Co., Ottawa, \$407.50; special pipe castings, Thomas Lawson & Sons, Ltd., Ottawa, \$3.50. In every case the lowest tender was accepted.

Personal

South Saanich, B.C., is in need of a permanent engineer.

J. H. Bottomley, secretary of the Welland electric light plant, has resigned.

Edward Hanson, late of the Montreal Light, Heat & Power Co., has been appointed electrical superintendent of light and power in Saskatoon.

Mr. J. H. Plummer, president of the Dominion Steel Corporation, will leave shortly on a business trip to Great Britain and the European continent.

W. A. Ostom, chief electrician in the Saskatoon power house, has resigned to re-enter the employ of the Canadian General Electric Co., as superintendent of construction in the west.

Harry Webb has resigned his position with the city of Winnipeg to take up a position with the Canadian Mineral Rubber Co., Ltd., as local manager, to succeed Mr. F. G. Pusey, resigned.

Charles Watt, superintendent of the mechanical staff of the Dominion Bridge Company, LaSalle, Que., was recently presented with a roll top desk on his severing connection with the firm.

W. F. Nickle, M.P., with a small deputation, called on the Ontario Government last week with a view to arranging for a formal request for a grant of \$40,000 for the School of Mines at Queen's University.

James Hutcheon, ex-city engineer of Guelph, has accepted a position in the Department of Lands, Forests and Mines at Toronto. He will continue to act during 1913 as Board of Works Commissioner of Guelph.

His Royal Highness, The Duke of Connaught paid a visit of inspection to the Angus shops at Montreal, when in that city recently. The men employed in the shops gave a first aid exhibition, and some other features.

Percival Lancaster, construction engineer of the C.P.R. on the route through Hastings, has been appointed city engineer, architect, and manager of Belleville waterworks at a salary of \$1,800 per annum, in succession to James G. Lindsay, resigned.

J. Grant Henderson has decided to resign as Industrial Commissioner at London, Ont. and to return to Hamilton, where he will be general manager of a new industry to be established there. Mr. Henderson's salary was \$2,500 per year.

George R. MacLeod, an applied science graduate of McGill University, has been appointed special city engineer for bridges, tunnels, railway crossings

and track elevations by the Board of Control, Montreal. His salary will be \$3,000 a year.

A. W. Roger Wilky, C.E., for the past eight years on the engineering staff of the Island branch of the Canadian Pacific Railway, has been appointed engineer-in-charge of all construction work of the Department of Marine and Fisheries for the province of British Columbia.

Thomas Coltrin Keefer, C.M.G., LL.D., of Ottawa, past president of the Canadian Society of Civil Engineers, and past president of the American Society of Civil Engineers, has been elected as honorary member of the Institute of Civil Engineers. Mr. Keefer is one of the most eminent members of the profession in Canada, and since his entry in 1838 he has rendered civil engineering inestimable service.

The Imperial Foundry Co., Ltd.,
Milton, Ont.
March 1st, 1913.

Canadian Machinery,
Toronto.

Gentlemen,—

We have for some time been trying to locate a company who manufacture tapping machines for small pipe fittings. We do not want a drill attachment, but a machine built for this purpose. Should you know of any such a firm we would be greatly favored by your letting us know of it.

Remaining yours very respectfully,
Imperial Foundry Co., Ltd.,
Jas. R. Tate,
Gen. Manager.

Captain J. D. Weir has been appointed superintendent of construction and of lights under the Montreal agency of the Marine and Fisheries Department. The appointment which was made by an Order-in-Council, is a popular one with the local departmental officials, owing to Captain Weir's long experience in the work which is now being entrusted to his charge. He joined the service in the year 1906, and from 1909 till 1911 was acting assistant to the superintendent in charge of the lights being confirmed as such in 1912, and remaining as assistant-superintendent until now, when he will take over the full responsibilities.

Mr. Joseph J. Brignall, for twenty-five years with the Canadian Pacific Railway, has been appointed travelling passenger agent for the Robert Reford Co., and general agent for the Cunard and Donaldson Lines, succeeding Mr. John J. Rose, who has been appointed Canadian passenger agent of the Union Pacific. He assumes his new duties on March 10. Mr. Brignall was born in Brougham, Pickering Township, and was educated at Pickering College and Whitby Collegiate Institute. He taught public school for three years, served as County court reporter, and finally entered the railway business.

Obituary

Walter K. Dryden, a sawmiller of North Dumfries, is dead, aged 86 years.

Former City Engineer Graydon of London, Ont., died at noon on Friday, Feb. 28, after an illness of about two weeks. He was appointed to the office in 1881 and retired in 1910.

Joshua Peters, a leading resident of Moncton, and for many years, until ill health caused his retirement, actively identified with the Record Foundry & Machine Company, died on Saturday evening, Feb. 22, in the 63rd year of his age. He was a native of Kent County, but for the past forty-three years had been a resident of Moncton.

Ex-Mayor John Chamberlain, Collingwood, Ont., is dead. In 1911 and 1912 he was chairman of the Water and Light Commission. While connected with the Commission he labored assiduously for the extension of Hydro power lines to Collingwood.

Sir William White, K.C.B., formerly chief constructor of the British Navy, died in London, Eng., on Feb. 26, aged 68, as the result of a stroke of apoplexy. He was a self-made man in every sense of the word, starting his career in the naval dockyard at Davenport as a shipwright apprentice, and rising rapidly until he became practically sole designer of the warships of the British Government. He was responsible for the designs of all the war vessels launched in Great Britain between 1885 and 1900. He was a member of the government was educated at Pickering College and Science and Technology, was chief constructor to the Admiralty and professor at the Royal School of Naval Architecture and at the Royal Naval College, and was assistant controller of the navy and director of naval construction from 1885 to 1902, when the development that produced the dreadnought got its start. Many engineering and scientific societies included him in their lists of honoured and honorary members.

Trade Gossip

Moulders' Wages.—The moulders of Hamilton are asking for an increase to \$3.25 a day.

The S. Morgan Smith Co., have secured a contract to supply the Ottawa Electric Co., with a pair of 48 in. "Smith" cylinder gate turbines of 1700 h.p. capacity, mounted on east iron draft chest.

The Pattern Makers' League of North America have decided by referendum vote to hold a Convention in June this year. The Convention will be held in

Detroit, and Canadian associations will be represented.

Alexander Gibb, St. Nicholas Building, Montreal, has been appointed sole Canadian agent for the sale of pulp grindstones, manufactured by the United Stone Firms, Ltd., of Bristol, England. The latter is a very large concern, having quarries in various parts of England, Wales and Ireland.

The Bowden Machine and Tool Co., of Toronto, are moving their plant from Orillia Street to Sterling Road, where they have erected a larger building. At present work is being carried on in both places. All the necessary new equipment has been purchased. In addition to its present product, the firm will manufacture pumps.

Escher, Wyss & Co., Montreal, have received the contract for a pump from the city of Regina for its waterworks system. The pump will have a capacity of 6,250,000 gallons per day and will be driven by a 200 horse-power Belliss and Moreom engine. The contract price for the entire equipment is \$16,000.

United States Steel Trade.—There are indications that the steel trade is slowing down somewhat in the United States, which is quite natural, as production has been gradually overtaking consumption. While the mills are operating to full capacity, orders show a falling off. Iron and steel production is larger to-day than at any time in history.

Bettington Boilers.—The Waterford Lake power house of the Dominion Coal Co., Ltd., the equipment for which was supplied by the Canadian branch of Fraser and Chalmers, Ltd., of London, Eng., is now in continuous operation. This central station supplies power for all the mines in the Lingan district, and is equipped with Bettington boilers. These have now been in use 3 months and are understood to be giving excellent satisfaction. The coal consumption per k.w. hour is remarkably low, although the lowest grades of slack and colliery refuse are being burned.

Business Change.—After negotiations, which have been going on for nearly eight months, Butterfield & Co., of Derby Line, Vt., and Rock Island, Que., have disposed of their entire business to the Union Twist Drill Co., Athol, Mass. Mr. J. H. Drury, treasurer of the latter company, recently visited Rock Island, and it is understood that, in addition to taps and dies, this plant will manufacture for the Canadian market the Union Twist Drill Co.'s well-known milling cutters. Mr. James Macgregor, president of the Union Twist Drill Co., is a

Canadian by birth, and was at one time engaged in the steel industry at New Glasgow, N.S.

Windsor, Ont.—The Canadian Alkali Co., Ltd., a \$2,000,000 corporation, has been granted a charter by the Province of Ontario, to operate an alkali plant on land recently purchased near the holdings of the United States Steel Corporation in Sandwich. The company will develop the salt beds underlying the property and by chemical treatment will manufacture salt, caustic soda, lye, and chloride of lime. The officers are James Inglis, president; William McBain, of Toronto, vice-president; M. G. Bergman, Detroit, treasurer; and H. S. Dodson, secretary and general manager.

Fraser and Chalmers, Ltd., Montreal, report that they have just closed a contract with the city of Medicine Hat, Alta., for all the steam, exhaust, water and gas piping in connection with the new municipal power plant. This is in addition to the contract which this company had already secured for the main power equipment. The latter consists of two 675 K.W. steam turbine driven alternators and two high lift turbine pumps of 3,000,000 gallons capacity each, together with condensers, exciters, switchboard, etc. Fraser and Chalmers are now shipping a Bettington boiler installation to the Dominion Department of Railways and Canals, for the Moneton shops of the Interecolonial Railway.

Ontario Metal Products Co., Ltd.—The business formerly conducted by Mr. F. J. Schuet was incorporated on Jan. 1st with a capitalization of \$40,000 and is now known as the Ontario Metal Products Co., Limited. Show rooms, offices and warehouse, at 102 Front St. East, Toronto. Canadian, American and German made metal products are handled, and a large supply of several lines are stocked, such as grease enps, brass and copper seamless tubing, seamless, cold drawn Swedish steel tubing etc. The Ontario Metal Products Co. represent P. L. Robertson Milton Co for screws, rivets, nails and wire; Geo. Wolfe & Son for washers, the Northern Bolt Works, for stone bolts and the National Acme Machinery Co., for caps and setscrews.

Catalogues

The Goetze Gasket and Packing Co., packing specialists, of New Brunswick, N.J., are sending out a hanger containing handy tables of gasket sizes for various pipes, and their prices.

The Hoppes Mfg. Co., Springfield, Ohio, make steam specialties. These are described succinctly in a booklet just out,

which the firm will, no doubt, send to anyone interested in feed water heaters, oil extractors, steam separators, exhaust heads, and the like. Their heaters are made to suit the requirements of any kind of water.

Bulletin 62, entitled "**The Electron Theory of Magnetism**," by E. H. Williams has just been issued by the Engineering Experiment Station of the University of Illinois. This is a mathematical discussion of the new theory of magnetism. The bulletin traces the experimental evidence leading to the development of this theory, defines its present status, and points out certain phenomena which the theory in its present form fails satisfactorily to explain.

New Incorporations

Benedict-Proctor Mfg. Co., Ltd.—incorporated at Ottawa, with \$25,000 capital, to manufacture silverware and metal goods at Toronto, Ont. Incorporators: Leo. E. Proctor, Wm. T. A. Proctor, Toronto, and others.

Process Engineers, Limited, incorporated at Ottawa, with \$100,000, to carry on the business of chemical engineers, etc.: Incorporators, John W. Cook, Allan A. Magee, Thomas B. Gould, Thomas J. Coonan, Pearl C. Mahoney, all of Montreal.

Wood Construction Company, Limited, incorporated at Ottawa, with \$50,000 capital, as general contractors at Montreal: Incorporators, Maurice Alexander, Patriek C. Dwyer, Richard W. Moore, Darley Burely-Smith, of Montreal.

Consumers Box & Lumber Co., Ltd., incorporated at Toronto, with \$500,000 capital, to manufacture shingles, etc., at Toronto: Incorporators, Henry T. Canniff, Philip R. Morris, Edna Annis, Walter J. Quimbach, Thomas H. Burcher, all of Toronto.

The Canadian Rotary Engine Company, Ltd., incorporated at Ottawa, with \$500,000 capital, to manufacture machinery at Winnipeg, Man.: incorporators, John McKechnie, William Brydon, James Fraser Stuart, James Miller, Hubert L. Call, Angus P. Cameron, all of Winnipeg.

Miller Bros. & Sons, Ltd., incorporated at Ottawa, with \$250,000 capital, to manufacture machinery, boilers, etc., at Montreal: Incorporators, William de Montmollin Marler, Louis H. E. Cholette, Jules A. Maucotel, of Montreal, Herbert M. Marler, of Drummondville, Donald McK. Rowat, of Westmount.

The General Market | Conditions and Tendencies

This section sets forth the views and observations of men qualified to judge the outlook and with whom we are in close touch through provincial correspondents.

Montreal, March 3.—Well sustained business was shown in the machinery trade last week, though there were no especially large transactions put through Dealers all seem well satisfied with present conditions and are highly optimistic as to the future. Business will probably be very brisk a month from now.

Money.

Conditions are but little changed Dun's "Bulletin," of Saturday, March 1, said of Montreal trade:—There is an increasing volume of complaint with regard to collections, more particularly remittances from the newer western provinces. Merchants claiming large surpluses are reported as returning drafts for quite small amounts, and there is apparently a growing disposition to more closely scan and restrict credits until conditions change.

In this old province of Quebec and Eastern Ontario, where more conservative methods prevail, remittances are better than from any other districts. The general money situation is unchanged and experienced financiers do not profess to see any prospects for easier money in the near future. Bankers are not entertaining any proposals for the opening of new accounts and in some cases are reported as restricting existing accommodation lines. Banking returns show a much lessened circulation.

Pig Iron.

Canadian pig was a little easier last week, with a fair demand. The English market fell, but this of course did not affect local prices, except to those buying for delivery after the opening of navigation.

Metals.

Copper is rather firmer than last week in sympathy with the rise in London and in New York markets. Tin is quiet at the same figure as last week. The demand for structural shapes, tubes and sheets continues brisk and deliveries are as hard as ever to secure. The comparatively mild winter has resulted in much demand for roofing material, reinforced brass, etc., the building trade having been exceptionally busy.

Toronto, March 5.—The machinery market here continues quiet, yet business is away ahead compared with that of a year ago, over 75 per cent. more business having been done in February, 1913, than in the same month of 1912. The Canada Foundry Co. will buy

rather heavily for their plant at Davenport, Ont., within the next few weeks. A motor company, which recently located in Brantford, Ont., will also be purchasing equipment before very long. The A. R. Williams Co. sold three large motor-driven machines to the Hydro-Electric system of this city during the past week, consisting of a lathe, a shaper and a drill. The Fairbanks-Morse Co. put through an order during the week for 150 4in., 6in. and 8in. valves for water works purposes at Hamilton, Ont.

Pig Iron.

The pig iron market continues quiet, buyers being still cautious, both here and in the United States. Inquiries would indicate however that new buying will take place before long, and that the price will still remain high. English pig iron is so expensive as to be unable to command a sale in this section of the Dominion.

Steel and Bars.

Canadian railways have been sending inquiries to American mills, the rail mills here being filled up for a year. There has been heavy buying of plates, shapes and bars during the past week. Business in the steel market is, however, almost entirely confined to warehouse. Warehouses in the States are in better condition to deal with the demand than those in Canada, they having had greater experience in anticipating congestion at the mills. In the near future warehouses in Canada should be in better shape to cope with orders.

Coke and Coal.

The big storm early this week will probably have the effect of making coal tight around Buffalo, and might also affect shipments of coke from the Connelville region. Shipments of coke are coming in better now from Detroit. The report was revived this week that the Solvay Process Co. were considering locating a branch plant in Sarnia, Ont. There is no duty on coke coming into Canada, and the question which would have to be considered most in connection with the establishment of a coke plant in Canada would concern the by-products more than the coke.

Metals.

There has been no rally in the metal market during the week, copper having dropped lower if anything. Dealers here are hopeful that a change for the better will take place next week.

NEW PLANT AT PETERBOROUGH.

MR. LEITCH, construction engineer of the De Laval Dairy Supply Co., Peterborough, Ont., announces that the company will proceed with the construction of two new buildings. One of these will be a warehouse and the other will be used for manufacturing purposes. The two of them will equal in floor space the present building, which is four hundred feet long and over one hundred feet wide. They will be of similar construction, and will be commenced as soon as the present building is completed. Construction work will be continuous and will be carried out by the J. W. Ferguson Construction Company of New Jersey.

The present building, which is nearing completion, will be available for manufacturing purposes within a week or so. Machinery is being installed, and men will be employed to operate the plant, as fast as the sections are completed. The building, which is located at the north side of the company's property, is divided into four sections—namely, machine shop, tin shop, carpenter, painting and construction departments. At present about forty-five men are employed, some of whom are on construction work and some installing the machinery.

Moving Machinery.

A large portion of the mechanical equipment from the St. John's factory has been shipped to Peterborough, and will be erected within the course of a few days. Mr. Leitch states that it is the company's intention to concentrate the Canadian manufacture of their product in Peterborough, and with this object in view will close up their eastern plant.

Regarding the manufacture of separators in Peterborough, Mr. Leitch intimates that they will only manufacture some of the patent parts in Peterborough, the remainder being manufactured at their plant in Poughkeepsie. The product to be manufactured in Peterborough will be dairy machinery of all kinds, such as apparatus for clarifying and sterilizing milk, silos, and the partial construction of separators. The cost of the two buildings will approximate about \$20,000.

The boiler room embodies the latest improvements, and will accommodate a battery of four boilers of an aggregate of 500 horse-power. A fireproof room separates the boiler room from the main building.

Sault Ste. Marie, Ont.—The Dominion Nickel and Copper co. will erect nickel smelters at a cost of \$5,000,000, four miles east of Sudbury, Ont.

SELECTED MARKET QUOTATIONS

Being a record of prices current on raw and finished material entering into the manufacture of mechanical and general engineering products.

PIG IRON.

	Per Ton.	
Foundry No. 1 and 2, f.o.b., Midland	\$20 50	\$21 00
Gray Forge, Pittsburgh		17 15
Lake Superior, charcoal, Chicago		18 00
	Mont'l. Tor'to.	
Canadian f'dry, No. 1	\$21 50	\$22 50
Canadian f'dry, No. 2	21 00	22 00
Middlesboro, No. 3	23 50	23 50
Summerlee, No. 2	25 00	26 50
Carron, special	25 00
Carron, soft	25 00
Cleveland, No. 1	24 25	25 00
Clarence, No. 3	23 75	24 50
Jarrow	25 50
Glengarnock	26 00
Radnor, charcoal iron	30 00	34 50
Ferro Nickel pig iron (Soo)	25 00

BILLETS.

	Per Gross Ton.	
Bessemer billets, Pittsburgh	\$29 00	
Open hearth billets, Pittsburgh	30 00	
Forging billets, Pittsburgh	36 00	
Wire rods, Pittsburgh	30 00	

FINISHED IRON AND STEEL.

Per pound to large buyers:

	Cents.
Common bar iron, f.o.b., Toronto	2.10
Steel bars, f.o.b., Toronto	2.20
Common bar iron, f.o.b., Montreal	2.15
Steel bars, f.o.b., Montreal	2.25
Bessemer rails, heavy, at mill	1.25
Iron bars, Pittsburgh	1.70
Steel bars, Pittsburgh, future	1.45
Tank plates, Pittsburgh, future	1.50
Tank plates, New York, future	1.61
Beams, Pittsburgh, future	1.50
Angles, Pittsburgh, future	1.50
Steel hoops, Pittsburgh	1.60

Toronto Warehouse f.o.b., Toronto.

	Cents.
Steel bars	2.30
Small shapes	2.45
Warehouse import, freight and duty to pay:	
Steel bars	1.95
Structural shapes	2.05
Plates	2.15

Freight, Pittsburgh to Toronto:

18 cents earload; 21 cents less earload.

BOILER PLATES.

	Mont'l. Tor'to.	
Plates, 1/4 to 1/2-in., 100 lbs.	\$2.40	\$2.40
Heads, per 100 lbs.	2.65	2.95
Tank plates, 3-16 in.	2.60	2.60
Tubes, per 100 ft., 1 inch	9.00	8.50
" " 1 1/4 in.	9.00	8.50
" " 1 1/2 "	9.00	9.00
" " 1 3/4 "	9.00	9.00
" " 2 "	8.50	8.50
" " 2 1/2 "	10.75	10.50
" " 3 "	11.95	11.50
" " 3 1/4 "	13.95	13.25
" " 3 1/2 "	14.50	14.50
" " 4 "	18.00	18.00

BOLTS, NUTS AND SCREWS.

	Per cent.
Stove bolts	80 & 7 1/2
Machine bolts, 3/8 and less	65 & 5
Machine bolts, 7-16	57 1/2
Blank bolts	57 1/2
Bolt ends	57 1/2
Machine screws, iron, brass	35 p c.
Nuts, square, all sizes	4c per lb off
Nuts, Hexagon, all sizes	4 1/4 per lb off
Flat and round head	35 per cent.
Fillister head	25 per cent.
Iron rivets	60, 10, -0 off
Wood screws, flathead, bright	85, 10, 7 1/2 p e off
Wood screws, flathead, brass	75, 10, 7 1/2 p e off
Wood screws, flathead bronze	70, 10, 7 1/2 p e off

WROUGHT IRON PIPE.

The following are Toronto jobbers' discounts on pipe. (Card weight) in effect from October 11th, 1912:

	Standard	Buttweld Black Gal.	Lapweld Black Gal.
1/4 3/8 in.	63	48
1/2 in.	68	58
3/4 to 1 1/2	72 1/2	62 1/2
2 in.	72 1/2	62 1/2	69 1/2 59 1/2
2 1/2 to 4 in.	72 1/2	62 1/2	71 1/2 61 1/2
4 1/2 to 6 in.	72	62
7, 8, 10 in.	66 1/2	54 1/2

X Strong P. E.

1/4, 3/8, 1/2 in.	64	54
3/4 to 2 in.	68	58
2 1/2 to 3 in.	68	58
3 1/2 to 4 in.	65	55
4 1/2 to 6 in.	63 1/2	56 1/2
7 to 8 in.	56 1/2	46 1/2

XX Strong P. E.

1/2 to 2 in.	43	33
2 1/2 to 4 in.	43	33

WROUGHT IRON PIPE.

The following are Montreal jobbers' discounts on pipe. (Card weight) in effect from October 11th, 1912:

	Standard	Buttweld Black Gal.	Lapweld Black Gal.
1/4 3/8 in.	64	49
1/2 in.	69	59
3/4 to 1 1/2	73 1/2	63 1/2
2 in.	73 1/2	63 1/2
2 1/2 to 4 in.	73 1/2	63 1/2	72 1/2 62 1/2
4 1/2 to 6 in.	74	64
7, 8, 10 in.	70 1/2	58 1/2

X Strong P. E.

1/4, 3/8	64	49
1/2 in.	65	55
3/4 to 2 in.	69	59
2 1/2 to 3 in.	69	59
3 1/2 to 4 in.	66	56
4 1/2 to 6 in.	65 1/2	58 1/2
7 to 8 in.	60 1/2	50 1/2

XX Strong P. E.

1/2 to 2 in.	44	34
2 1/2 to 4 in.	44	34

IRON PIPE FITTINGS.

Canadian malleable, 40 per cent.; cast iron, 65; standard bushings, 70; headers, 60; flanged unions, 65; malleable bushings, 65; nipples, 75; malleable, lipped unions, 65.

COKE AND COAL.

Solvay Furnace Coke	\$5.25
Solvay Foundry Coke	6.50
Connellsville Furnace Coke	5.75
Connellsville Foundry Coke	6.25
Yough. Steam Lump Coal	3.75
Penn. Steam Lump Coal	3.63
Best Slack	2.95
All net ton f.o.b. Toronto.	

OLD MATERIAL.

	Tor'to.	Mont'l.
Copper, light	\$11 00
Copper, crucible	14 00	13 5
Copper, unre'bled, heavy	12 00
Copper wire, unre'bled	12 00
No. 1 machine compos'n.	11 00
No. 1 comp's'n turnings	10 00
New brass clippings	9 00	9 00
No. 1 brass turnings	7 50
Heavy lead	3 25	3 00
Tea lead	3 50	3 00
Scrap zinc	3 50	3 75
Toronto dealers' purchasing prices.		

SMOOTH STEEL WIRE.

No. 6-9 gauge, \$2.35 base; No. 10 gauge, 6e extra; No. 11 gauge, 12 extra; No. 12 gauge, 20e extra; No. 13 gauge, 30e extra; No. 14 gauge, 40e extra; No. 15 gauge, 55e extra; No. 16 gauge, 70e extra. Add 60e for coppering and \$2 for tinning.

Extra net per 100 lb.—Spring wire; bright soft drawn, 15c; charcoal (extra quality). \$1.25.

METALS.

Prices in cents per pound:

	Mont'l.	Tor'to.
Lake copper	16.50	15.75
Electrolytic copper	16.50	15.75
Spelter	6.25	5.75
Lead	4.25	4.20
Tin	51.00	50.00
Antimony	9.75	9.50
Aluminum	22.00	22.00

SHEETS.

	Mont'l.	Tor'to.
Sheets, black, No. 28....	\$2 85	\$3 00
Canada plates, ordinary, 52 sheets	2 80	3 00
Canada plates, all bright.	3 70	4 15
Apollo brand, 10¾ oz. (American)	4 30	4 20
Queen's Head, 28 B.W.G.	4 40
Fleur-de-Lis, 28 B.W.G..	4 20
Gorbal's Best Best, No. 28	4 45

NAILS AND SPIKES.

Standard steel wire nails, base	\$2 40
Cut nails	\$2 60	2 65
Miscellaneous wire nails..	75 per cent.	
Pressed spikes, 5/8 diam., 100 lbs.	2 85

FINE STEEL WIRE.

Discount 25 per cent. List of extras. In 100-lb. lots: No. 17, \$5; No. 18, \$5.50; No. 19, \$6; No. 20, \$6.65; No. 21, \$7; No. 22, \$7.30; No. 23, \$7.65; No. 24,

\$8; No. 25, \$9; No. 26, \$9.50; No. 27, \$10; No. 28, \$11; No. 29, \$12; No. 30, \$13; No. 31, \$14; No. 32, \$15; No. 33, \$16; No. 34, \$17. Extras net. Tinned wire, Nos. 17-25, \$2; Nos. 26-31, \$4; Nos. 30-34, \$6. Coppered, 75c; oiling, 10c.

MISCELLANEOUS.

	Cents
Patty, 100 lb drums	\$2.70
Red dry lead, 560 lb. casks, per cwt.	6.25
Glue, French medal, per lb	0.10
Glue, 100 flake	0.11
White lead, ground in oil, No. 1 pure, 100 lbs.	8.40
Tarred slaters' paper, per roll...	0.95
Motor gasoline, single bbls., gal..	24½
Benzine, per gal.	23½
Pure turpentine	64
Linseed oil, raw	58
Linseed oil, boiled	61
Plaster of Paris, per bbl.	2.10
Plumbers' Oakum, per 100 lbs..	4.25
Pure Manila rope	17

TRADE WITH BRITAIN.

THE official returns of the Board of Trade for January contain the following figures regarding British trade with Canada:—

Imports From Canada.

	Jan., 1913	Jan., 1912.
Wheat	1,167,200 cwt.	1,564,700 cwt.
Meal and flour...	259,800 cwt.	237,800 cwt.
Oats	38,200 cwt.	5,700 cwt.
Maize	4,200 cwt.	8,400 cwt.
Cattle	510 head	
Bacon	24,004 cwt.	36,216 cwt.
Hams	6,808 cwt.	3,760 cwt.
Cheese	33,435 cwt.	51,275 cwt.
Salmon	32,508 cwt.	41,277 cwt.

Exports to Canada.

Spirits	98,503 gals.	106,288 gals.
Sugar	16 cwt.	4,111 cwt.
Wool	169,500 lbs.	134,400 lbs.
Hides	3,207 cwt.	1,731 cwt.
Pig iron	1,426 tons.	2,228 tons.
Tinned plates	456 tons.	1,171 tons.
Cutlery	552 cwt.	427 cwt.
Hardware	2,115 cwt.	1,707 cwt.

The total value of imports from Canada during 1912 was \$134,402,510, against \$122,969,725. The value of the Canadian exports last year was \$117,562,475, against \$98,575,290 in the previous year.

MR. PLUMMER OPTIMISTIC.

THE continued weakness in Dominion Iron has, among other things, led to rumors that possibly the dividend was not secure. Talk of this kind has not been taken seriously by most well-informed people, but it has no doubt shaken the confidence of a few holders.

Mr. Plummer, president of the Dominion Steel Corporation when passing through Montreal last Saturday on his way to Sydney, said: "The question of altering the dividend policy has never been discussed by the directors in

any shape or form. We have paid the dividends through the very trying period of the past two years, and all I need say is that the outlook for larger profits this year is excellent."

Mr. Plummer expects the entire new plant to be in operation in a very short time, so that the annual statement that will be out about a year from now should be a very much more satisfactory document than the statement due this spring, which, latter, it is thought, will, in spite of the bad iron markets of the last year, show about five and a half per cent. earned on the common stock after the customary liberal allowance for depreciation.

DOMINION STEEL CORPORATION.

THE Dominion Steel Corporation's rail business this financial year will be the largest one on record, heavy shipments being still reported from the Sydney plant.

The steamer Heracles is leaving Sydney shortly with 7,350 tons of rails destined for British Columbia. The steamer Strathtay sailed a few days ago with a cargo of 6,000 tons of rails, also for British Columbia. The opening of the Panama Canal will mean much for the Corporation in its western shipments on account of the quicker and more economical deliveries that it will make possible on Pacific Coast business.

In addition to these large water shipments, the Corporation is making shipments of rails by land at the rate of 20 to 25 cars a day.

South Porcupine, Ont.—The owners of the Dome mine will install a forty, and possibly a sixty stamp mill this year.

SITUATION WANTED

WANTED—POSITION AS TRAVELLER OR accountant by young man with seven years' experience in machinery and iron trades. Both languages. Furnish bond or references. V. D. Poulin, Box 428, St. Johns, Quebec.

SIDE LINES WANTED

MANUFACTURING CONCERN IN ONTARIO having splendidly equipped factory wants good live article to manufacture on contract or royalty. Box 123, Canadian Machinery & Manufacturing News. (10)

PATENTS
PIGEON, PIGEON & DAVIS

71A, ST. JAMES STREET, MONTREAL
Phone, Main 3025
16 years' experience in Canada, U.S. and Europe

TRADE MARKS, COPYRIGHTS & DESIGNS
PATENTS
LLOYD BLACKMORE & COMPANY
LUMSDEN BUILDING, TORONTO.
ALSO, HOPE BLDG. OTTAWA & WASHINGTON, D.C.
We have an interesting and valuable booklet "PATENT PROTECTION" which will be sent free upon request.

PATTERNS
WOOD AND METAL
Allow us to estimate. Satisfactory work guaranteed.
TAYLOR PATTERN WORKS WALKERVILLE, ONT.

The Motor Truck Feature at the Toronto Automobile Show

Staff Article

Just recently has it been realized that not only is the motor being substituted for the horse in the conveyance and transportation of passengers, but that the animal is passing away as a drawer of heavy loads as well. One of the most striking sights on our streets to-day is the number of motor trucks hauling merchandise of every kind and weight. The motor truck exhibits at the recent show were, as a natural consequence, numerous and varied.

THE Toronto Automobile Show was held in the Government and Transportation Buildings, Exhibition Park, and was quite distinct from any previous event of its kind; to a great extent the industrial car made the difference. This latter feature was the first thing to impress one on entering the exhibition; the rough bulk, enormous gears and drives of the motor truck being objects of more concern and attention almost than the graceful lines and immaculate appearance of the dainty electric. Manufacturers and warehousemen are realizing that if they are to keep abreast of the times they must substitute motor trucks for horses as soon as possible. There were commercial cars, from the light lightning mail vans on pneumatic tires to the heavy dray with a chain drive as thick as one's wrist.

During the year just closed there were 34,701 gasoline cars built on this Continent, which is greatly in excess of the number estimated, while figures supplied by manufacturers show that this year 80,000 gasoline commercial cars will be built. In 1911 there were 246 firms making gasoline trucks; while this year there are over 304. In the case of electric commercial cars, the increase is not so marked, the figures being 29 and 37 for the two years.

It has been shown by actual test and

experience that a car costing \$3,000, used in almost any kind of service where road conditions are practical, will show a net saving of over 40 per cent. per annum over the old-fashioned horse delivery.

Packard Trucks.

One of the most distinctive exhibits at the Toronto show was that of Packard's, the American firm, who make trucks in three sizes—2-ton, 3-ton and 5-ton chassis. The first of these, with its adaptability to all loads up to its maximum, is especially valuable for expressing and for the transportation of light but bulky commodities. The 5-ton machine is for hauling ponderous loads. The Packard automatic dumping body is operated by power from the motor controlled by a lever within the driver's reach. It stops automatically on reaching an angle of 40 degrees, and can be made to stop at any intermediate position.

Detroit Electric Trucks.

Much interest was shown in the 1½-ton Detroit electric truck, which is similar to that operated by the Robert Simpson Co., of Toronto, for the haulage of furniture. It is equipped with type A-6 Edison battery of 60 cells, having a rated capacity of 225 ampere hours, which will drive this truck under average conditions 40 miles on one normal

charge of the battery. After six months of use, the capacity of the battery increases to 270 ampere hours, and the mileage to 50, on a single charge. The feature of this truck is that it may be stored in horse stable, factory or warehouse without affecting the insurance of the building. The Ontario Motor Car Co., Ltd., are the Toronto dealers.

The "Alco" Truck.

At any exhibition where motor trucks are to be found one looks for the Alco. They are so common on the street now, especially for heavy loads. These machines were to be found in the exhibit of the Montreal Locomotive Works, Ltd., Montreal, Canadian representatives of the American Locomotive Co., who make the Alco. In their 6½-ton machine the motor has four cylinders of 5 ins. bore and 6 ins. stroke. The horse-power is 40, and the carrying capacity 13,000 pounds. The Alco truck is also made in 5, 3½ and 2-ton sizes.

The "Brantford" Truck Co.

The exhibit of the Brantford Motor Truck Co., Ltd., Brantford, Ont., compared favorably with that of any of the well known American firms. They have broken away from the pleasure car type of truck, believing that a commercial car should be built along simple and strong lines. They have fewer parts on their cars than any on the market.

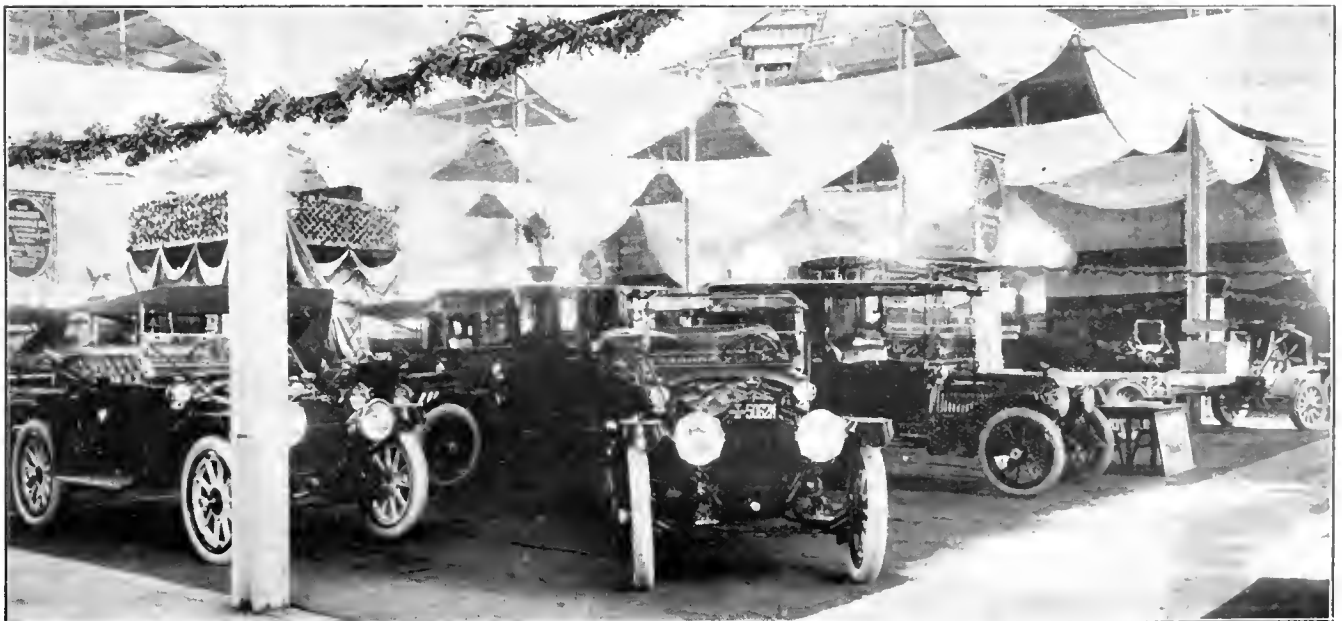

A CORNER OF THE TORONTO MOTOR SHOW.

The Brantford truck is made in two sizes—one with 1,000 lbs. carrying capacity, and one which carries 2,000 lbs., with a 50 per cent. overload. The

International motor is designed especially to do commercial work, and is simple in construction. In addition to the magneto system of ignition, the In-



THE "PACKARD" MOTOR TRUCK.

motor on the smaller car is water-cooled, 4-cylinder, 4-cycle, $3\frac{1}{2}$ in. bore, $4\frac{1}{2}$ in. stroke. The cylinders are cast in pairs.

The "Albion" Truck.

The Albion Motor Car Co., of Glasgow, Scotland, who will shortly erect a plant in Montreal, claim to be the largest manufacturers of motor trucks in the British Empire. The wheels of their trucks are of cast steel, and the engine is equipped with a powerful governor controlled from the driver's seat, which enables the truck to be run at any speed up to the maximum. Another feature of this truck is the patent dry disc clutch, which protects the mechanism from damage by poor drivers. Their capacities are from one to five tons. An order was placed recently with this company by the C. P. R.

The "International" Truck.

The motor truck made by the International Harvester Co., Hamilton, Ont., is almost as well known as their implements. They have been on the market for a number of years with their truck, and from the start there has been a constant growth in the volume of sales, until to-day it is built in one of the largest factories in the world. The

ternational engine has an entirely separate and independent source of ignition. The high speed is direct, the engine pulling the load on the main shaft



1 1/2-TON "DETROIT" ELECTRIC TRUCK, MADE FOR THE ROBERT SIMPSON CO., LTD., TORONTO.

without the aid of gears. The International is specially adapted to work on a farm, and where roads are not of the best.

they exhibited three cars which drew considerable attention. They build trucks in sizes from $\frac{3}{4}$ to 5 tons. The drive consists of a steel worm and a worm wheel made of special phosphor bronze. The wheel is bolted to a casing containing the differential gears, and gives a high mechanical efficiency. The motor is of the long stroke, four cylinder, four cycle type.

The White Truck.

The White Company, Toronto, Ont., make trucks for heavy work in two distinct models, with carrying capacities of 3 and 5 tons respectively. They are also built in capacities of $\frac{3}{4}$ and $1\frac{1}{2}$ tons, for delivery service. The 3-ton truck has an engine of 30 h.p., four cylinders, cast in block, bore $3\frac{3}{4}$ in., stroke $5\frac{1}{8}$ in. The valves are all on one side, and valve-stems and springs are completely enclosed by detachable plate. Ignition is by high-tension magneto only.



THE "MONARCH" TRUCK, MADE AT HAMILTON, ONT.

A shaft drive is used, with two universal and one telescopic joint from gear case to jack shaft. Power is transmitted to the rear wheels by side chains. The wheels are made of special steel castings, reinforced by webs. The tires are solid, and in the rear are dual.

near their sources, are torrents subject to wide variation in flow. The generally rocky nature of the mountain riverbeds renders the construction of dams a comparatively simple matter, but the wide variation in the stream flow makes either natural or artificial storage bas-

south, which is much larger, in Quesnel lake. The total length of the river is approximately 70 miles.

The South branch passes through two rocky canyons which present excellent opportunities for power development. The upper canyon, about an eighth of a mile in length, is at the foot of a series of rapids which reach almost to the lake, nearly three miles above. It is about 300 feet deep and has precipitous and rocky banks, making the construction of power development works comparatively easy. A 30-foot dam combined with the present available head of 150 feet.

Three miles lower down is a second and similar canyon, about one-quarter of a mile long, its physical features corresponding in general to the upper. A feature that makes the South branch of the Quesnel remarkable as a water-power project, is the dam at the outlet of Quesnel lake. This dam was constructed for mining purposes at a cost, it has been stated, of \$400,000, and is of material assistance in improving the storage and regulation facilities of the lake.



2-TON "MACK" MOTOR TRUCK.

The "Mack" Truck.

The Canadian Fairbanks-Morse Co., Ltd., seemed to monopolize a good part of the show with their Mack trucks, marine engines and accessories. With a staff of men both smart and courteous, they made a very favorable impression. The

ins a necessity, in order to utilize to advantage, the potential energies of these rivers. As the hot sun of summer melts the glaciers and thus creates a heavier run off, many mountain streams are always at their maximum flow during the summer months.

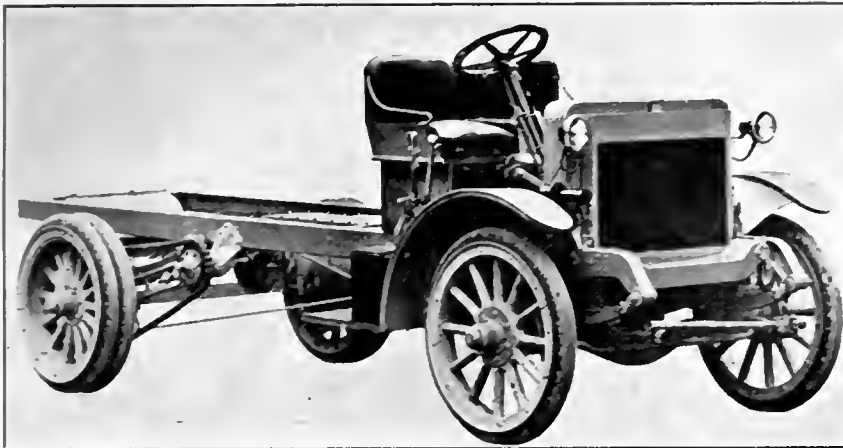

2-TON CHASSIS OF THE "GRAMM" MOTOR TRUCK.

sizes of Mack trucks are 1, 1½, 2, 3, 4, 5 and 7½ tons, giving a correct size for every kind of service, from light delivery to the heaviest haulage, and any style of body for any size of truck required. The word "Mack" is strictly confined to motor trucks, the firm not being manufacturers of pleasure cars. The clutch transmission is used.

Potentialities of Quesnel River.

Keeping in mind these conditions, it is of interest to consider specifically some of the streams, the power-sites on which have been examined with a view to their possible development. One of these is the Quesnel river, a tributary of the Fraser. At its junction with the latter river, the Quesnel flows through a deeply cut channel. The river valley in general passes through a district composed of gravelly foot-hills, thinly timbered with birch, poplar and other small growth, the whole watershed having been swept by a forest fire years ago. The river is comparatively short for the volume of water it carries, and it divides into two branches some seven miles from its sources; the north branch taking its rise in Cariboo lake, and the

LARGE GAS ENGINES.

IN the first of his lectures, entitled "Recent Research in the Gas Engine," which he delivered before the Royal Institution, Professor Bertram Hopkinson said that the great obstacle which lay in the way of the development of the large gas engine was the problem of cooling. The trouble is not so much that heat is abstracted from the gas by the cooling water, or that when the diameter of the cylinder is above 23 ins. provision must be made for cooling the piston, but that a widely differing temperature is existent between the opposite sides of the cylinder wall, resulting in severe stresses. It was formerly supposed that the heat from the gas was transferred by means of conduction and convection, but more recent experiments, made by putting a flourite window in a gas cylinder and placing a bolometer for measuring radiant heat in line with it, show that the transference is actually made by means of radiation. The solution of this difficulty, therefore, lies in the direction of "bottling up" the heat thus radiated, and with this end in view, if the inside of the cylinder be brightly polished, the walls will radiate the heat back to the gas.

POWER SITES IN BRITISH COLUMBIA.

BRITISH Columbia is rich in water-powers. Most of the rivers are mountain streams, and consequently possess the advantages and disadvantages for power purposes that usually characterize such. Many of them,

Port Arthur, Ont.—Approval of the plans for the intake pipe and the new water works has been received from the provincial health officer.

Comparison of Motor Driven with Horse Drawn Vehicles

By R. W. Hutchinson, M.E. *

A Handful of Data Covering Actual Performance is Generally Worth a Bushel of Assumed or Estimated Achievement, and in the Realm of the Motor Truck, There is Being Determined Convincingly, by Practice and Accounting, the Hard and Stubborn Fact that Not Only Is Its Serviceability Generally Higher for Commercial Purposes, But Its Economy is Also Unquestionably Ahead of the Time-Honored Horse-Drawn Vehicle.

STATEMENT (A) gives a detail of the annual operating expense and saving made by the Cable Placing Department of the New York Telephone Co., the data having been compiled from the performance of ten 3-ton Mack trucks, with an average mileage of 10,900.

Statement (A).

Chauffeur's salary (full time, including overtime)	\$1,146.50
Garage and washing	240.00
Gasoline (.0635 per mile)....	397.85
Lubricants (.0171 per mile)..	186.39
Tires (.55 per mile)	599.50
Supplies (miscellaneous)....	54.50
Repairs	240.00
Depreciation, interest & taxes	1,020.50
Total	\$3,885.24

annual operating expense and saving made by the heavy aerial construction gangs of the New York Telephone Co., the data having been compiled from the performance of seven 3-ton Mack trucks on an average mileage of 5,310:

Statement (B).

Chauffeur's salary (part time) \$	360.00
Garage and washing.....	240.00
Gasoline (.0635 per mile)....	331.87
Lubricants (.0325 per mile)...	172.57
Tires (.055 per mile).....	292.05
Supplies (miscellaneous)....	54.50
Repairs	120.00
Depreciation, interest & taxes	750.00
Total	2,320.99

The approximate gross annual saving on horse-drawn vehicles was as follows:

A Saving of \$400 Per Month.

An interesting example of the money saving feature of the motor truck is found in the experience of the American Car and Foundry Co., Chicago. This concern, it is obvious, has transportation that belongs to the heavy duty, long haul class. A year's operation of a 6½-ton Saurer truck on an exact cost accounting basis shows that this truck transported 14 1-10 tons per day a distance of 33 miles at an average cost of 6.45 cents per day, or a per ton cost of 45.8 cents. Adding to this per ton cost, interest on the investment at 6 per cent. and all necessary motor vehicle insurance, together with an annual overhauling fund of \$450, the total cost per ton transported becomes 78 cents. With rented horse equipment their former cost was \$2 to \$2.50 per ton. In other words, the Saurer truck is saving the

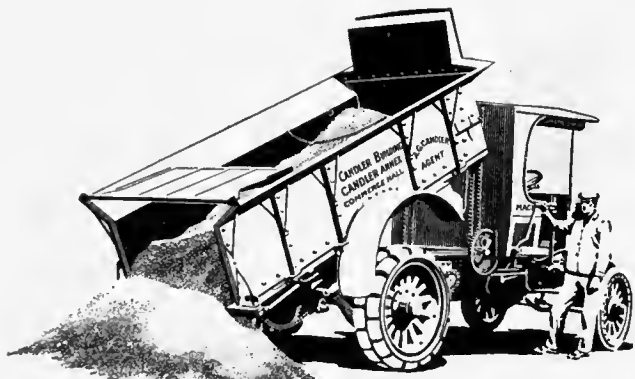

5-TON "MACK" DUMPING TRUCK USED BY THE LAKE WINNIPEG SHIPPING CO.



2-TON "MACK" TRUCK IN SERVICE FOR THE CAN. FAIRBANKS-MORSE CO., MONTREAL.

The approximate gross annual saving on horse-drawn vehicles, based on seven months' usage, was as follows:

Truck hire (Aug. to Feb.)...	\$2,904.20
Car fare (Aug. to Feb.)....	361.69
Freight (Aug. to Feb.).....	118.00
Total for 7 months	\$3,383.89
Approximate annual saving.	5,800.00
Approximate annual saving on placing cable	500.00
Total	\$6,300.00
Approximate gross annual saving	6,300.00
Annual operating expense of truck	3,885.24

Net annual saving per truck \$2,414.76

Teams for hauling men, tools, etc.	\$1,450.00
Placing cable	350.00
Extra truck for hauling poles	150.00
Extra truck for hauling cable	300.00
Traveling time of men	1,200.00
Labor, setting poles	300.00

Total for year	\$3,750.00
Approximate gross annual saving	3,750.00
Annual operating expense of truck	2,320.99

Net annual saving per truck. \$1,429.01

The chauffeurs operating these trucks were experienced linemen, who worked with the gang when the trucks were standing idle; hence part of their expense is properly chargeable to the work.

American Car and Foundry Co, about \$400 per month, which represents a return on the investment of 98 per cent., or is sufficient to pay for the truck after one year of service.

Additional specific data on the economy of motor trucks could be quoted, but space does not permit, besides the multiplication of examples simply serves to add greater emphasis to the general proven fact that a motor truck intelligently installed, intelligently handled and cared for, and operated in the manner dictated by its manufacturers, never fails to show, either a large direct saving in dollars and cents, or by keeping transportation costs at a standstill, trebles or quadruples in many instances the zone of business in which its owner can efficiently operate.

*Of the International Motor Co.

FURNACES FOR TOOL STEEL.

AN order for a battery of six large annealing furnaces for the heat treatment of tool steel bars has been placed with Mr. Victor Stobie, of Sheffield, by the Midvale Steel Co., Philadelphia. This installation is stated to be the largest of its kind in the world, the total capacity being 7,500 tons of steel bars annually. The furnaces, which are built underground, are fired by producer gas, and can be regulated in 50 to 100 sections, according to the length of each. During the last six years, Stobie furnaces have been adopted by a number of large steelworks on the Continent of Europe, four of which have lately begun to export tool steel to America. The progress being made by tool steel makers in different countries is indicated by the capacity of the furnaces they put down: the size usually preferred is of 8 to 10 tons capacity, and it is rare for fewer than two such furnaces, each turning out two or three heats a week, to be working together, while Stobie furnaces, having a capacity of 20 tons per heat, are in regular operation. In Germany, the bars are usually rolled 16 ft. long, but Stobie plants have been built for lengths up to 28 ft. A Stobie 5-ton electric steel furnace is shortly to be erected in Germany.

SOME NOTES ON GRINDING.

"LOADING" is the condition in which some of the ground-off material adheres to the face of the wheel, and "glazing" is the condition in which the cutting grains and their bond are on an even plane on the wheel surface. In grinding copper, "finish" is always proportional to the fineness of the wheel.

The color of a grinding wheel does not affect the cutting quality or the life; the cause is the difference in color of the bond used. The use of compound in grinding improves the cutting and prolongs the life of the wheel, and, to get true grinding economy, there must be co-operation between the grinding and turning departments. Often the grinding machine is not given due credit for the saving in turning, made possible only by the grinding methods. As a rule, the greatest economy is obtained by the combination of grinding with very rough turning.

By simply changing the speed of either the wheel or the work, failure is often turned into success, and transferring a wheel, after it has worn down to a small diameter, from a large machine to a small one is a good plan. Always true the wheel at the speed at which it is to be used. Long life in a wheel, secured by sacrificing rapid production, is not economy.

Considerable differences in diameters of work will affect the cutting of a wheel on any given material. A hard wheel is more apt to change the work temperature or to become glazed than a soft one; also, it requires more power to do the same amount of work. Reducing the width of the wheel necessitates using a finer feed, and consequently doing less work. Ignorance is at the bottom of most evils in grinding.—H. Pearman, in "The Machine Tool Engineer."

CARE AND LUBRICATION OF AIR COMPRESSORS.

THE following memo has been prepared by Mr. James L. Davidson, secretary of the Alabama Coal Operators' Association, under the approval and direction of the Mine Casualty and Mining Institute Committee.

Having noticed in the Alabama Supreme Court Reporter a decision, awarding heavy damages to the administrators of a man killed in the mines by gas from the exhaust of a compressed air driven pump, when he went to start up the pump; the secretary takes the liberty of giving you the following information gathered from reliable sources, with regard to the care and operation of air compressors, involving safety and efficiency:

It is a fact that air compressors frequently pollute the mine air with dangerous gases, and sometimes explode, causing damage to persons and property. In either case, the same may be generally attributed to the excessive heating, in the presence of compressed air, of the oil and foreign substances that have collected in the cylinder, discharge pipes and air passages, and especially in and around the valves. Volatilization and ignition of oil and other carbonaceous matter occur very rapidly in the presence of highly heated air. The greatest heating takes place where the air passes from the cylinder into the discharge pipe. Even although the compressor is equipped with modern and approved cooling devices, insufficiency of size or too many angles in the discharge pipe, incrustation of dust mixed with oil, at the discharge opening, decreasing the capacity of the discharge may each or all produce enough heat to cause an explosion, or produce dangerous gases, which should not enter the mine.

Two Important Points.

It is therefore important:

First—to keep the compressed air while being compressed, at as low a temperature as possible.

Second—To prevent oil and other carbonaceous substances from collecting in

any part of the machine or in the discharge pipes.

All ports and air passages should be as large as practicable and should be kept free from obstructions and incrustations. In addition to partly closing the ports, incrustation often causes the valves to stick, resulting in disastrous consequences. When the valves stick it causes a "Back Kick" and considerable friction in re-compression, which produces great heat.

The Oil Feature.

To avoid incrustation and collecting of oil and foreign substances in the machine and discharge pipes, high-grade non-carbonizing oil may be used and should be properly fed into the cylinder. Petroleum oil, especially free from volatile carbon, with flash point of not less than 625 degrees F. is recommended. The oil should not be too dense nor contain animal or vegetable oil. Do not in any case, use ordinary steam cylinder oil, because the heat in the steam cylinder is moist, and the surplus oil is washed out, whereas the heat in the compressor cylinder is dry, thus causing the oil to stick and cake. For the above reason, and also on account of the difference in the character of the proper lubricant and the work it has to perform the proper feeding of oil, to the compressor cylinder, is very different from the oil feed to a steam cylinder.

Too much oil causes incrustation, and a surprisingly small quantity of good oil will give sufficient lubrication to air compressors. Watch your compressor and cut the amount of oil down to a minimum of its requirements. Oil should not be allowed to collect in the machine, and in case it does, it should not be allowed to remain, but should be drawn off immediately. Even when using the best oil, properly fed to the cylinder the machine should be cleaned frequently, or when needed.

Dont Use Kerosene.

Do not use Kerosene for cleaning! It is very dangerous. Kerosene has a flashpoint of about 120 degrees F., and the temperature of the compressed air may at any time reach 300 to 450 degrees F. and cause an explosion. The best and safest method of cleaning is to feed into the air cylinder, soapsuds, made of one part of soft soap, to 15 parts clean water. Feed a liberal amount of this solution into the cylinder instead of the oil for a few hours or even for a day, if necessary. The accumulation of this water and oil should be drained off from time to time during the process by opening the blow off valve at the receiver.

To prevent rusting it is necessary to run the machine and feed oil into the cylinder for an hour or so after the

cleaning process is completed and the water drained off, so that the valves and all parts connected with the cylinder will become coated with oil before shutting down the machine.

Air Temperature.

The temperature of the discharged air should never exceed 250 degrees F. The machine should be watched, and if the temperature exceeds the above, it should be shut down and cooled. If possible, the cause of overheating should be eliminated before starting up again.

The temperature increases as the pressure increases, therefore it would be well to equip all air compressors with an automatic pressure or temperature regulator, which will allow the compressor to run idle as soon as the pressure or temperature in the receiver reaches a predetermined limit, and likewise bring the compressor into action again as soon as the pressure or temperature falls below this limit. There are regulators on the market which apply to compressors coupled direct to the engine, or driven by electric motors, or driven by belt and pulleys. As an extra precaution, a fusible plug may be placed in the discharge pipe near the compressor. This plug should be constituted to fuse and blow out at a temperature of between 325 and 350 degrees F.

Remember that proper construction, proper care of the machine and high-grade lubricants, may save life, and are cheaper than shut downs, lost power, destruction of property and damage suits!



LEATHER BELT DATA.

At a recent meeting of the Birmingham Association of Mechanical Engineers, Mr. R. Berry stated that after a long experience with leather belt drives he had found a good all-round rule, and one easily remembered for belt calculations, to be that 1 ft. per minute of belt speed per inch of width of belt is safely equal to the transmission of 1 watt of electrical energy. If we, therefore, multiply the band speed in feet per minute by the width in inches, the result will be the total energy in watts, and if we divide the result by 1,000, the energy is obtained in kilowatts, which energy the band may be relied upon to transmit without any undue tension being brought upon any part of the belt or excessive friction in any part of the machinery. These data, however, only apply to single leather belting or to woven belting of a similar thickness. If a light double band be employed, then 25 per cent. more energy may be calculated upon; or for heavy double leather belting as much as 60 per cent. more may be added.

The great advantage claimed for this method of calculation is that it fixes a constant for working tensions, so that the working tension becomes directly proportional to the width in inches, this constant being 44.24 lb. pull per inch width of belt. If we wish, therefore, to know the difference in pounds pull on the tight and on the slack side of any belt, all that is necessary is to divide the total output of the machine in watts by the velocity of the belt in feet per minute, and multiply the result by 44.24, and the product will be the extra pull in pounds on the tight over the slack side.



COMBINES AID TO INDUSTRY.

Dr. Adam Shortt, of the Civil Service Commission, appeared before the Old-age pensions Committee of the Commons, at Ottawa, recently and gave evidence as an expert in political economy. He dealt at considerable length with the economic problems underlying the various proposals for a state pension system, pointing out the serious difficulties attending any scheme of compelling workmen to contribute towards a Government old-age pension fund, and maintaining that any non-contributory system was unsound economically, socially and morally. He suggested as a substitute a system of national insurance.

Combines.

Speaking of national conditions of unemployment, he drew the attention of the committee to the fact that a salient feature of modern economic development was that in the last 15 or 20 years there had been no long periods of general industrial depression such as occurred prior to the trust and combine period. The reason, said Dr. Shortt, lay in "the concerted action of producers in getting together and regulating their output so that they shall not overdo the thing, so that they shall not starve each other out. That is the beneficent feature, of course, of the combination, yet it is a feature to be considered in what I consider the wild and miscellaneous talk about those combines. They represent a real and thoroughly sound development in industry, but the power to regulate is also the power to coerce, and no proper distinction is made between the regulative power merely and the coercive power."



3,000 TON TESTING MACHINE.

The 3,000-ton testing machine erected last year in the Royal Testing Station in Berlin is operated hydraulically, and is designed to receive struts and tension members 50 ft. long. In using this apparatus, special attention is paid

to flexure and collapse of columns, and resistance of riveted joints. All heavy parts of the machine are of forged steel. According to the Zeitschrift des Vereines deutscher Ingenieure, two 200-atmosphere water pressure buffers are provided to absorb the shock when rupture takes place. The high pressure pistons are packed with cup leathers.



ELECTRICAL FIRM EXPANDS.

INCREASED business has made larger premises necessary for Chapman & Walker, Ltd., electrical engineers and contractors, Victoria Street, Toronto. They have begun to move their stock and equipment into their new four-storey warehouse, 116-120 Richmond Street West. By concentrating all their offices and warehouses in this building they will be able to carry a larger stock and have better facilities for giving an efficient and expeditious service. Their new building is modern in every respect, and is equipped with the most up-to-date system of fire protection. It is of a mill construction, with floors measuring 60 x 110 feet. On the ground floor there will be extensive showrooms of machinery and supplies, with ample accommodation for all sizes of motors and accessories. The upper floors have been sub-let for short periods, the intention of the firm being to move into them as fast as the business expands. The building is provided with a freight lift, supplied by the Roelefson Elevator Co., of Galt., Ont.

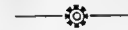

TRADE DISPUTES.

THERE was further improvement in industrial conditions with regard to the number of trade disputes during January. At the end of the year 1912, there were seven disputes in existence of such magnitude as to affect industrial conditions and two of these were settled during January. Five new disputes occurred, a feature of which was the fact that by none of them were more than one hundred employees affected. Disputes in existence in January were twelve in number as compared with thirteen during December. The number of employees affected also showed a decrease, being 2,298, as compared with 3,850 during December. There were seven disputes left unterminated at the end of the month.

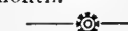

William Norman Ashplant has been appointed city engineer of London, Ont., to succeed George W. Wright, who resigned some time ago. H. A. Brazier, who has been occupying the position temporarily, will be offered the position of assistant.

Factors of Scientific Management Other Than Labor*

By Frederic A. Waldron **

The writer of this paper breaks away from the now well-worn groove into which scientific management has revelled so long—that of the human element, and shows under a series of heads, that the primary factors involved are not only outside the sphere of the workman, but constitute a menace to his attainment of a high degree of efficiency.

LITERATURE published in the last few years on scientific management has dealt largely, if not almost entirely, with the labor problem. The theme has been a discussion of various methods of rewarding labor in order to obtain increased output. Other elements tending to the maintenance of factory output have been for the most part, ignored. Scientific management, in its highest sense, can be likened to the proper functions of the human body, in which each one carries its portion of the load, does its share of the work at the proper time, and distributes energy in proper proportions to all parts of the human frame. Of what avail then would time study and high-speed machines be, if the proper materials were lacking, and how efficient would microphotographic work be, if the store-room did not have sufficient supply of finished parts on hand to assemble the machines?

Again, of what avail would the most elaborate system of time study be if it were costing more to manufacture than the goods would sell for? In fact, what would any of this be worth if your business could not be obtained, and the funds also, whereby the payroll and bills for labor and materials be met, or a demand and use created for the output?

Factory Order Requirements.

There has been more or less tendency, in the management of industries, to divorce the financial and sales organizations from the factory or shop management in such an arbitrary manner that the two act in a way indicating that each is working for itself, regardless of the broader interests of the company of which each is a part. So long as the sales end can get the orders to the factory and get credit for such orders, the fact as to whether this order contains enough specific information to complete, is ignored, and it is left for the factory to make it out and guess at it. A most serious loss in volume of output is or may be caused by this. All orders, before being turned into the factory, should be complete and specific as to what is required. By this is meant completeness and not abridged completeness.

*From a paper read at a recent meeting of the New York members of the American Society of Mechanical Engineers.

**Industrial Engineer, New York.

Balance the Organization.

I can recall in several instances in my experience where an output of from fifty to one hundred thousand dollars of business was held awaiting detailed information on minor items before the order could be shipped. Two men at a salary of fifteen hundred dollars per year apiece would have rounded up this information in ample time to allow of the prompt shipment of these orders. Keep your entire organization in balance. Don't overload sale and advertising departments if the factory cannot handle the work. Build up on a solid foundation surely and gradually. Educate, not in factory alone, but along the entire line.

Output Feature.

In the excitement of the moment, the fact of quality of output should not be lost sight of; it should be watched closely and improved at every point.

Quality cannot be maintained by the mere placing of tools, instructions and drawings in the hands of the workman. This man must be trained and it takes time and money to train him and unless this training embodies the elements of thoroughness and completeness, the workman becomes a half-rate, slipshod man looking for payday and taking little if any interest in his work. Every green workman broken in means sacrifice in profits, quality and volume of output. Therefore, ideal factory conditions rest almost entirely on one basic principle, that of constant volume of output. It is not always possible to maintain this, owing to conditions that may arise, such as the matter of orders, capital, and the proper supply of materials and help. We should, however, try as these weak spots develop, to build them up in such a way as to make conditions tend in the direction indicated, for it is better to work at a steady, even gait for a year, than to intensify the production to a point where all the work is done in six months and your factory is idle for the remaining six months.

Further, the quality of intensification in output often depends on matters entirely extraneous to the labor problem and factory management. In other words, the business and factory ends of our enterprises require synchronizing or bringing into step, so that they work in harmony with each other, tending to-

ward maximum economic conditions and profit. The extent to which time study should be carried depends entirely on these conditions, and the expense incurred by ultra-refinement could better be invested, oftentimes, in raw materials or finished stock of proper quality. It is the province of the industrial and efficiency engineer to help guide the manufacturer as to how far he should go in a question of this kind.

A factory with an undersold output is no place for a premium or bonus system. Accurate and simple accounting and routing are requisites here. With an oversold output, a premium, bonus or piece rate system, based on accurate time study combined with accurate and simple accounting and routing are necessary to produce the maximum efficiency on the shop end, combined with a purchasing inspection and stock department that can keep pace with a well developed shop organization.

Purchasing Feature.

The most effective co-operation between the factory and purchasing departments is as essential as time study or production engineering work. Of what avail are time study and intensified production, if the purchasing agent buys materials, at the lowest price, that will not meet the requirements of the product in quality? The answer is simple. Work is thrown away before it is assembled, or if sent out in the finished product it will react on business in time to a fatal degree. The requirement is to buy to specifications, and see that you get the material before it is needed, and that the specifications are conformed to.

Serious delays and expense are often caused by improper specifications for simple materials and supplies. The lack of this information on requisitions made by superintendents, foremen and clerks on the purchasing department is a current trouble in many factories. It can be obviated by a symbol or number system which ties all materials used in the factory to a standard specification of definite and complete wording.

Requisitions to the purchasing agent, reading as follows, should be avoided: "Same as last order;" "seventeen 1/2-inch screws;" "20 feet of lumber;" "50 gallons of oil;" "100 pounds of steel."

These are examples of what should be studiously avoided, being mere signs in-

dicating that the individual wants something, but of what it is, the purchasing department must find out. This requires time and money and causes serious delay.

Low prices paid for materials are not necessarily exponents of a purchasing agent's efficiency. The man who can discriminate and buy the right thing at a fair price is the kind of man that lasts in this period of competition and exacting requirements.

Engineering Feature.

A product improperly designed and well made cannot maintain its place in the market, and, conversely, a product properly designed and improperly made cannot be sold. To properly design and see that it is properly made, is the measure of efficiency of the engineering department.

Proper strength, lines, proportions, tolerations, inspection, instructions, manufacturing specifications, tool design and manufacturing, should be done in this department and done thoroughly. Time, study and bonus system are thrown away if done on work that cannot be used, or hurts your trade. Further, responsibility is more readily placed. This division is really, in the modern organization of high efficiency, the most important of all, as it is the fountain head from which all specifications are issued, designs made and quality of work determined.

Inspection Feature.

Proper materials for the workmen is the first and most important duty required, and following this should be proper tools, condition of machines, jigs and fixtures for reasonable performance of acceptable production. The above functions are just as necessary to efficient work as time study or bonus system, for, without these, the intensified production would be lacking, owing to the fact that conditions for perfecting the work would not be constant and the failure to perfect such work would be beyond the workman's control.

This division, having brought the foregoing requirements to the proper standard of efficiency, has now a hold or control of the quality of the work as specified by the engineering division, and is in a position to insist on its quality being maintained.

Maintenance Feature.

There are some fifty or more reasons why a workman cannot do a full day's work, all of which are beyond his control, and fully and properly up to the management. An engineer cannot make his running time if his locomotive lacks proper grates or steam capacity or is in bad repair. Neither can a workman

make his time unless he has proper light, heat, power machines, tools and fixtures, etc., in proper working condition.

One of the most common troubles is the condition of belts. This was long ago recognized by F. W. Taylor and covered in his paper on "Shop Management." His system, with the belt, bench and scales, in a factory using many belts, is the best obtainable and shows direct results in volume of output and saving in belt bills. Countershafts, main shafts, jack shafts, motors, machine repairs, should receive systematic supervision to insure constant and efficient operation. True, time study develops these requirements, but these requirements should be attended to first, or time study will in a way be wasted unless conditions of operation are reasonably constant.

Accounting Feature.

To have reasonably accurate costs is desirable and necessary, not only as a means of efficiency but also to eliminate unprofitable articles of manufacture and produce the more profitable ones. To secure this, requires methods of factory accounting which interlock with routing system, timekeeping, and stores, together with a close co-operation with the stores, production and producing work of management.

Proper distribution of overhead charges, accurate time study and charges, accurate material charges, controlled from a central point in which all is charged against its proper account by

the same mental interpretation, is the only accurate way, combined with a symbol method, not too complicated, which places the burdens where they belong at the time the expense is incurred.

Stores Feature.

Unless raw and worked materials are properly accounted for, it is impossible to tell "where you are at" so that the truthful conduct of a stockroom is another important and necessary function outside of the workman. Stores records should be complete and show enough information to gage efficiency without being so complicated and cumbersome as to require more time to tell the story than an inventory. Maximums and minimums should be so proportioned as to allow a minimum amount of capital being tied up in fixtures, stock, raw materials and work in process as well as in all materials spoiled or defective. A graveyard in a store, in plain sight of all, is a mighty good object lesson to the management and the workmen.

The broad or commercial interpretation of efficiency engineering, or scientific management, is profitable management, in which the final measure of success is the return on the investment. As this return is dependent on other than labor elements, it would seem but fair that we carefully and earnestly consider the fact that no man can do efficient work at a machine unless the conditions are made right for the performance of such work and that each function of the industrial organization requires as close attention, if not more, than that which refers directly to the reward of labor.

The Question of Low Grade Fuel for Motor Trucks

In the development and progress of the automobile and motor truck to date, it will be found that gasoline as the fuel has played a not inconsiderable part in the large measure of achievement attained. Its cost, however, is becoming prohibitive, and if the industry, of which these mechanisms are the product, is to extend and still further prosper, other and less costly fuels must be made available.

THE immediately available substitutes for gasoline are kerosene, distillate and naphtha.

Kerosene is exceedingly plentiful, low in cost, and uniform in quality, promises to continue in abundance, and, if demanded in large quantities for motor fuel, could be disposed of in the domestic market with greater profit to the refiner than when marketed abroad, as is so largely done at present.

Engine distillate is a product obtained from the Western crude oils after the lighter fractions have been distilled off, and, in a way, is analogous to kerosene in respect to its position in the scale of petroleum derivatives. It is less

thoroughly refined, however, and at present is to be considered principally as a local product. Its practical equivalent could be produced from other asphaltic oils, such as those of Texas and Mexico.

Naphtha is as indefinite as gasoline. In its present use it is intended to embrace not only the heavier fractions that commonly are included with the gasoline distillation, but also the fractions between gasoline and kerosene, which are at present lost to the automobile fuel market. Being slightly more volatile than kerosene, and moreover free from the doubtful reputation that kerosene enjoys as a fuel, it should prove easier

to introduce—first, because the user is in no wise prejudiced against it, and, second, because its employment entails less experimental development.

In considering the comparative utility of different fuels, particularly as between gasoline and the lower-grade petroleum distillates, there is little question of thermal equivalents. Whatever difference exists is, if anything, in favor of the heavier products. Volatility, however, as expressing the ease with which the mixture may be generated, is of paramount importance. Volatility, viscosity and gravity together indicate the comparative facility with which a fuel can be reduced to the condition of a dry or wet mixture and so delivered to the engine.

Carburetion.

That a liquid cannot be carburetted by ordinary methods need not condemn it for use in the internal combustion engine, although it does exclude it from consideration as a fuel for automobiles of present construction. In this respect the carbureter is really the determining factor in fuel selection. As the values of volatility, viscosity and gravity are lowered, the fuel becomes, respectively, harder to vaporize, more difficult to force through small orifices and requires a greater lifting effect (suction) to overcome its superior mass per unit of volume. With the heavier fuels, therefore, different proportions must be employed in the carbureter in order to obtain results corresponding to those obtained in successful instruments designed for gasoline. It is evident at least that a carbureter designed for heavy fuel may be more satisfactorily operated with gasoline than a gasoline carbureter with heavier fuel. To assist in the vaporization of the lower-grade fuels, more heat is necessary than for gasoline. This is due largely to the fact that the latent heat of the heavier fuels is greater than that of gasoline.

Starting Appliances.

It is reasonable to conclude that a mechanical starting device will always be required for low-grade fuel motors, and that in addition either the use of a high-grade fuel for the first few moments of operation will be necessary, or else a method of priming. In many respects the latter method is preferable, especially if acetylene be used, since it permits starting without special carbureter adjustment (other than choking of the air), simplifies bi-fuel tank and piping complication, and further introduces into the primary charges a high-velocity combustible which serves as kindling material for what is practically a normal charge.

There is every reason to believe that in the natural course of events engine-

starting appliances will soon become a practical necessity on all motor vehicles, so that the development of such devices for commercial vehicles in connection with the adoption of low-grade fuels need not be viewed in the light of a special and purely incidental burden. Practically speaking, starters are more necessary on commercial vehicles than on pleasure cars, through their economic advantage in conserving the driver's energy, and because they permit the shutting down of the engine for all loading stops.

Commercial Car Feature.

As a large proportion of commercial vehicle types may be said more truly to be in the early stages of evolution than are pleasure vehicles, it follows that the adaptation of special apparatus for handling low-grade fuels will work

less hardship on the truck manufacturer than it would if forced on the builder of established types of pleasure vehicle. Further, the higher valuation placed on operating economy by the commercial vehicle purchaser must tend to render the kerosene or naphtha-burning machine a more acceptable offering in that field than a pleasure car possessing the same feature would be in its field. Indeed, were it possible to offer almost any large truck user a carbureter that would handle a low-grade fuel as efficiently as his present carbureter handles gasoline, there is little question that he would accept the substitute immediately, on the basis of a not unreasonable performance guarantee.—From a paper read recently before the Society of Automobile Engineers in New York by Mr. N. B. Pope.

Interesting Example of Bench Lathe Utility

By A. L. Monrad

It is not, perhaps, quite as fully realized as it might be, that the bench lathe is capable of a large variety of production adaptation. In any case, we believe the data and illustrations constituting this article can be studied with interest and profit by a wide circle of our readers.

THE accompanying drawings show the novel adaptation of a bench lathe into a surface milling and grinding machine for making fine, true tool work. So far as accuracy is concerned, the bench lathe makes an ideal machine tool and in an up-to-date manufacturing plant, the toolmaker has one supplied, together with all appurtenances and accessories for his own exclusive use. Its upkeep is, therefore, of the best, and it is quite astonishing to see the large variety of product that can be accomplished by such a machine, not only for small and delicate pieces, but for large work as well. In a particular instance, large 22 in. face-plate work was to be

undertaken and in order to have it clear the lathe bed and the head and tailstock had to be raised up on six inch blocks. New and improved designs of various attachments have broadened the field of usefulness of the bench lathe, so much so that instead of being confined to boring and turning only, it becomes available for surface milling, milling screw-thread, profiling, shaping, planing, cutting, chasing, diamond grinding, turret work, etc., by applying the different attachments to suit the required operation.

Example of Application.

To make six pieces hardened, ground, and lapped as shown in detail at (A)

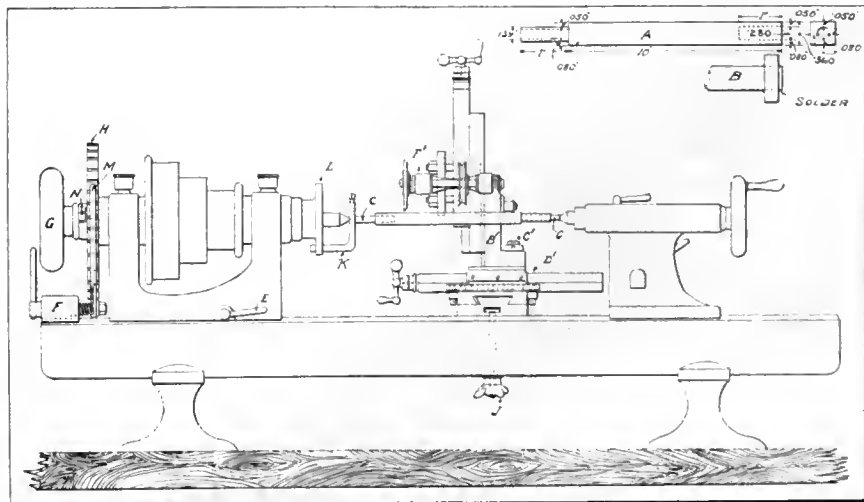

FIG. 1 INTERESTING EXAMPLE OF BENCH LATHE UTILITY.

Fig. 1, from 7-16 in. square tool steel, the following method was adopted: After the pieces had been centered, cut and turned on each end to measurements in the bench lathe, allowing .01 inch for finish grinding, 6 brass bushings with a 7-16 inch square hole were soldered on the end as shown at (B) Fig. 1 the same outside diameter being turned on these bushings with the aid of a steady rest. Both ends of the work (A) were drilled, bored and reamed to dimensions which allowed .005 inch for diamond grinding to finish size. A centre plug (C) was next inserted in each hole, care being taken not to drive the plugs in too hard, but just enough to hold while milling the square. A small spiral groove was filed on the diameter of each plug to allow the air to pass out from the bottom of the hole. The headstock, unloosened by turning the handle (E), was shifted along the lathe bed to make room for the index block (F). The draw-in handle (G) was removed and a number 80 index plate (H) inserted on the end of the headstock spindle. The handle (G) was again replaced to draw-in the male centre of the spindle. A milling fixture (I), Fig. 2, was placed between the two centres of the lathe and adjusted so that the slide with the cutter would reach across both ends of the work, the attachment being clamped in place by a hand nut (J) from underneath the bed. When everything had been placed in position, with a hard-wood wedge between the dog (K) in the slot of the face-plate (L), the panel (M) of the index block (F) was placed in the zero groove of the index plate. The work having been set approximately parallel with the cut-

ter, the screw (N) in the index-plate (H) was tightened up. For indexing four sides, No. 20, 40, 60, and 80, grooves were used when milling.

A light milling cut was taken across the four sides on each end, just enough to square up the work sufficiently to hold the ends in two small vises (S) for finishing cut shown in Fig. 2. The head and tailstock were next taken off the lathe bed and a small angle iron (O) 4in. x 4in. x 12in. strapped on the top of the latter by two bolts (P) extending through the centre ways of the lathe. On top of this angle iron was placed another angle iron (Q), about the same size as the first. This was held by a parallel clamp (R) on each end. A test indicator was then placed in the milling fixture spindle, and all corrections made on the top surface of the angle iron so as to be parallel both ways with the milling attachment. Two small toolmaker's vises (S) were strapped on top of the angle iron by means of a strap (U) on each side. With a parallel (V) of proper height, the work was held at each end in a vise, care being taken not to spring the work while clamped in the vise.

To get the proper adjustment, it is necessary to unloosen the straps (U), screw tight the vises with the work in place and set the vises parallel with the milling fixture by using a square on their side from the front end of the top angle iron, assuming, of course, that this is parallel with the attachment. Next strap the vises down securely in place, take out the work, and put an indicator in the milling fixture spindle and see if the inside face of the solid jaws on each vise are parallel with the at-

tachment. This ensured that the work will not spring during working operations, and that it will come out square and parallel.

The feed screw in the cross slide of the milling attachment having been removed, the lever (W) was used in its place in order to feed back and forth more rapidly during milling and grinding operations. This lever was pivoted on an extension block (Y), which was held stationary on the lathe bed by a bolt (Z) through the ways of the lathe and secured with a hexagon nut (X). The other end of the lever (W) had a slot about 2in. long by 1/2in. wide, which works on a stud (A') screwed on the end of cross slide, from which the feed screw plate was removed.

Before the finishing cut is taken, an indicator is placed in the milling attachment spindle, and necessary corrections made by going across both ends, .230 diameter, with the pointer to see that they are of the same height. By using a depth gauge from the top flat surface of the work down to the diameter, the .080 inch and .050 inch measurements can easily be obtained +.007 inch on the side for grinding.

Hardening the Pieces.

To properly harden these pieces, a soft wire basket is made in the following manner. Take about 2 ft. of 1-32 in. soft wire and wind a bottom seat in the middle of the wire just large enough for one square end to rest on. Take both ends of the wire and wind it spirally around the outside of the work, and with the extreme end of the wire, make a loop for a grip with the tongs in this manner, all the pieces are placed separately in a round cast iron pot and packed with fine ground charcoal. A cover made to fit has a 1/8 in. hole in the middle, into which is placed a soft wire, somewhat smaller in diameter than the hole, but long enough from the bottom of pot, to extend 1 inch above the cover when in place. Fire clay is pasted about 1/2 in. thick on top and around the side of the cover to prevent air from getting in to the work. Place the pot in a gas furnace and give it a very low and slow heat for about two hours. Lift up the soft 1/8 in. wire while the pot is in the furnace and note if it has the proper heat. If so, remove the cover while the pot is still in the furnace and plunge quickly, one piece at a time into a sperm oil bath, surrounded on the outside of oil chamber with ice water in order to keep the oil always cold. Afterwards, heat the hardened work over the furnace just long enough to take off the strain, then allow to cool off naturally on a piece of wood or rag. Do not allow it to lay on a cold piece of steel as

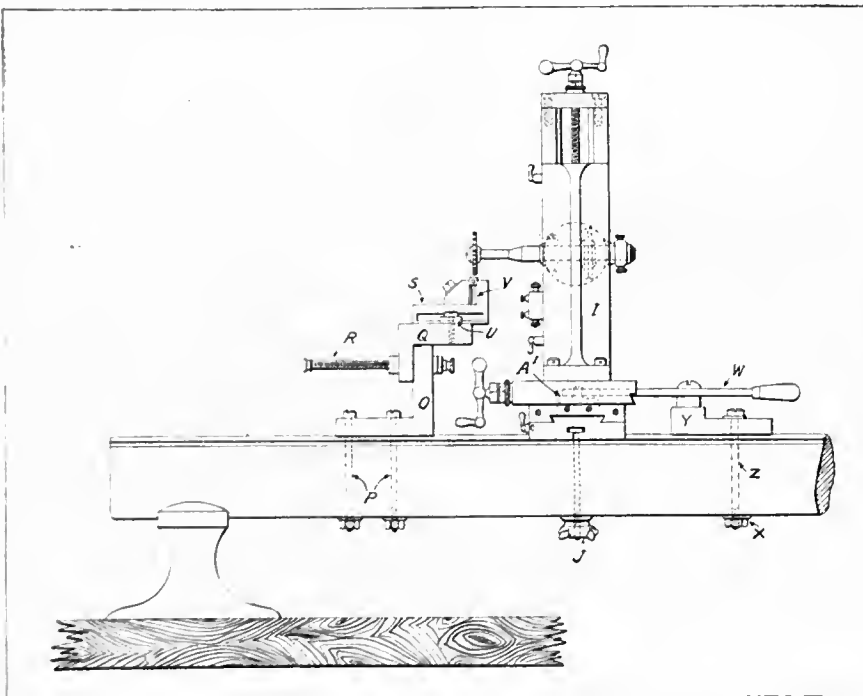

FIG. 2. INTERESTING EXAMPLE OF BENCH LATHE UTILITY.

its tendency will be to spring and crack. When the work is cool enough to handle, polish all the surface.

Lap out each end hole sufficiently to clean it round. Make a centre plug to fit each hole rather snug, but no driving fit, as this will surely crack them. Polish off the four sides on the square end, replace the brass bushing with a little solder as shown at (B) Fig. 1, then turn off the diameter. Next grind the diameter on the other end, just enough to clean it, and all of the same size. Should this be done to finish size before the inside hole is ground, the price will go all out of shape.

Take out the centre plug on the square end, place the steady rest on the brass bushing and grind the hole to finish size, allowing .0002 inch for lapping. A centre plug, made for this hole, is used while grinding the other hole, precisely in the same way, only that the diameter is ground at the same time.

The headstock is now moved forward, and the index plate, panel and block replaced as shown in Fig. 3, the compound rest being utilized instead of the milling fixture. A sliding angle iron (B') is placed on top and keyed in the tool-post—T slot. This is held securely by a bolt (C') and large spanner wrench nut. On the side of this sliding angle iron is strapped the tool-post-grinder (E'), having allowance to overhang the work sufficiently for cross grinding. The cross feed screw is taken out of the compound rest. With the lathe in same position as when milling, a light grinding cut is taken on four sides of each end of the square, just sufficient to clean up, by holding the right hand on the compound cross slide and pushing back and forth while feeding in with the handle on the left hand. After both ends have been squared up, the bench lathe is taken apart and replaced with the angle irons (O-P) and toolmakers vises (S) Fig. 2, while the compound slide rest (D') and sliding angle iron (B') remain in the same position. The lever (W) extension block (Y), etc., are replaced as for milling attachment Fig. 2. In this way, the work is ground in exactly the same manner as when milling, allowing .0003 for lapping.

The foregoing details of operation proved in every way highly satisfactory for the production of 6 absolutely interchangeable pieces and may be of value to others, engaged in this particular line of work.

Toronto, Ont.—Robt. S. Hunt was recently awarded \$2,500 damages for the loss of a foot, sustained while taking down casings from a cement roof when the scaffold broke. John E. Webb Co., were the defendants.

THE AGE OF THE BUSINESS MAN.

By Elbert Hubbard.

THE Honorable Mark Anthony made a little speech at the funeral of the late Julius Caesar, wherein he paid a great compliment to his subject. Among other pleasant things reported by the press, Mr. Anthony said, "He brought many captives home to Rome, whose ransoms did the general coffers fill."

Julius Caesar knew only one way to make money, and that was to hold somebody up. He knew how to use the taxing power of the State, and if the parties taxed did not respond he knew how to go after them and collect the amount due. He fined one concern in Gaul 29,000,000 sesterces, and collected it on a body attachment, vulgarly called kidnapping.

Julius Caesar was a lawyer, and, as a rule, a lawyer knows only one way to make money—and that is, to get yours. The business man of to-day is a creator, a builder and an economist. He who thinks otherwise is a Marxian Socialist and a small-bore petty diplomat.

The only way to make money is to render a service for humanity: to supply something that people want, and to carry things from where they are plentiful to where they are needed. Again, he who confers the greatest service at the least expense is the man whom we will crown with honor and clothe with riches. Any other policy is running on its rim on the high clutch, headed for the cliff.

We live in an age of business, and economies is fast becoming a science. There is only one sin, and that is waste. Disuse and misuse are both forms of waste. The best brains of the world are at work now endeavoring to eliminate lost motion and take up the economic slack, and the men who are making the biggest fortunes are making their money out of by-products. That is to say, the thing that was once thrown away and discarded is now being coined into cash.

Half of the population in America are engaged in farming, and farming is a primal need, because we get our food out of the soil. Next to food, love is the chief requisite, and no man is loving, lovely or lovable who is on half rations. Richard Cobden put this concisely when he said: "The ratio of marriages keeps pace with the price of corn." Only well-fed people are capable of love, and a corn-fed product is always prosperous. Next to farming in importance comes transportation, because a thing has to be at a certain place at a certain time in order to possess value. The railroads bridge time and annihilate space.

The third most important thing in the world is manufacturing, which is taking

raw products and combining them into forms of use and beauty; while the fourth most important thing is distribution. Our great cities are centres where vast warehouses are located, and these warehouses gather together the products of the farm, the factory, the mine and the sea, and distribute them to the millions who need them.

The fifth most important thing in the world is banking. The banker is one who takes the savings of the people and loans out again a certain per cent. of these savings to people who can use money to make more money. Statistics show that, with a fair capital to start on, the banker can safely loan out 85 per cent. of his deposits, and at all times stand ready to meet the cheques of his customers. Banking is a great move in economies, as it keeps money active instead of allowing it to be stored away in the ginger jar and in the unsafe and unsanitary clock, where the mice and cockroaches do congregate and thieves break through and steal you to a standstill.

The sixth most important thing in the world is advertising, and advertising is telling who you are, where you are, and what you have to offer the world in the way of service or commodity. The only man who should not advertise is the man who has nothing to offer, and such a person is a dead one—whether he knows it or not. For him, Charon's mud-scow is grating on the sands, and the boom of the surf can be heard just beyond the harbor-bar.

INCREASED MINERAL OUTPUT.

AN increase of \$29,906,495, or nearly 29 per cent. is shown by the preliminary report on the mineral production of Canada during 1912. The total value of the year's production was \$133,127,489, and nearly every important mineral in Canada shows an increased production, so far as value is concerned. In the case of silver only, is there a decrease in quantity, and this is but two per cent., the increase in total value of the silver mined being due to higher prices.

Increase in outputs are as follows:—Pig iron, 10.5; gold, 28; copper, 40; and lead 50 per cent. Increases in total values are:—Silver, 12; nickel, 31; copper, 85; and lead 93 per cent. Coal shows an increase of 30 per cent. in tonnage, gypsum 11, and cement 26. Ontario is credited with 38 per cent. of the total production, or \$51,023,134, while British Columbia, Nova Scotia, Alberta and Quebec follow in the order named.

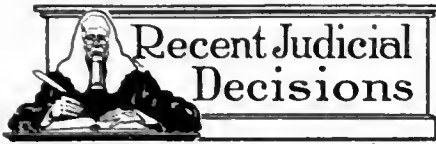

Orillia, Ont.—Plaintiff in the action of *Wells v. Town of Orillia*, has consented to accept judgment for \$4,250. Damages were asked for injuries to a boy by a live wire hanging down among the branches of a tree, whereby the boy's head was badly burned.

Brampton, Ont.—The Toronto Appeal Court has dismissed the appeal by defendant in the case of *Gower v. Glen Woollen Mills* from a judgment, in which a minor was awarded \$2,000 damages for injuries sustained, while engaged in defendant's employment, whereby his left arm was torn from the shoulder by reason of a ladder slipping while he was endeavoring to put a belt on a pulley.

Windsor, Ont.—The Toronto Appeal Court has dismissed the appeal of the defendants in the action of *Montreuil v. Asphalt Block Co.* from judgment of a Divisional Court of 21st October, 1912. Action was entered by Montreuil for \$3,000 damages for injuries to his home and property, alleged to have been caused by smoke, noxious odors, limestone dust, and noise from defendant's factory. At the trial, judgment was awarded plaintiff.

Regina, Sask.—Papers have been signed settling for \$200, the action brought against the city by *Martin Nargang*, began last September for \$827 for damage to a traction engine used by the city last year in *Boggy Creek*. It was claimed by *Mr. Nargang* that the engine was damaged owing to the failure of the employees of the city to wash out the boiler. The city solicitor deposited \$200 into court, expressing willingness to settle the case for this amount.

Toronto, Ont.—In an action *Denison v. Gillett*, brought by Toronto architects to recover from defendants \$1,100 claimed to have been paid by plaintiffs at defendant's request for a Clerk of Works or superintendent of the building of a new factory by defendants, the following judgment was rendered: I am convinced that *Mr. Dobie* instructed the plaintiff, *Denison*, to engage a clerk of works for the defendants company and agreed that the company would bear the expense. There will be judgment for plaintiffs for \$1,100 with interest costs.

Peterborough, Ont.—The Appeal Court at Toronto has dismissed an appeal against the judgment of a Divisional Court of March 8, 1912. An action was brought by *Catherine Darke* against the

Canadian General Electric Co., for \$10,000 damages for the death of her husband, *Hugh Darke*, while in the employment of defendant company, caused, it is alleged, by one of defendant's employees starting the engine, thus causing the belt upon which deceased was working to revolve rapidly, whereby he was whirled around a pulley and crushed to death. At the trial the jury awarded plaintiff \$1,800 damages, but the Judge, on motion for non-suit or judgment dismissing the action, dismissed the action without costs. The Divisional Court reversed that judgment and awarded plaintiff \$1,800 damages and costs.

COMBINED SPRINKLER AND HEATING SYSTEM.

A COMBINED sprinkler and heating system is in use in a large cotton mill in New Bedford, Mass. The building, 237ft. by 300ft., has a basement and one storey, and is covered by a saw-tooth roof. The sprinkler system is supplied by an Sin. pipe from the yard mains and a steam pump. In the basement the entire sprinkler system is used for heating, no other heat being provided. The sprinkler heads are of the *Grinnell* glass bottom type designed to melt at about 160 degrees Fabr. The hot water has an average temperature of about 200 degrees Fabr., and at times reaches a maximum of 245 degs. Fabr.

According to *Mr. Gorham Dana*, of the National Fire Protection Association, overheating of the sprinklers is prevented by placing them in offset pipes about 12in. long and 1/2in. in diameter. These offsets are 3in. above the main pipe and connected to it by a 1/2in. elbow and nipple. It is said that the action of hot water on the iron pipe causes a segregation of free nitrogen from the air in the water, and this gas collects in the space adjacent to the sprinkler heads. The gas acts as an insulator, and as there is no circulation of water through the offset pipes, such heat as reaches them by conduction is radiated into the atmosphere before it has a chance to melt the fusible caps.

TESTS OF LARGE VOLTAGE OIL CIRCUIT BREAKERS.

SOME tests on large voltage oil circuit breakers were recently carried out at the plant of the Hydraulic Power Co., Niagara Falls. The tests showed that a circuit breaker should have an operating mechanism giving quick and positive action. Breaks as quick as 0.09 secs. have been obtained, the usual time varying between 0.3 and 0.6 sec., de-

pending on the method of tripping and the type of circuit breaker and instantaneous relay. The voltage disturbance increases with the speed of operation, the phenomena depending on the nature of the load carried by the generator. A long time element limits the shock to the circuit breaker when opening circuits with large power and low impedance, but allows a considerable drop in voltage and extensive destruction at the point of short circuit. It is impracticable and undesirable to interrupt a short circuit during the first cycle when the current is at a maximum. The shock to the generator is not eliminated by any practicable speed of working. The effects of action and reaction at the moment of breaking were also considered, but the results showed that perfectly satisfactory apparatus can be used on large power systems, even when the operating conditions are very severe.

ELECTROCUTED IN ODD WAY.

V. BAKER, one of the survivors employed by the Hydro-Electric Commission, was instantly electrocuted on Friday, February 28, at *Centreville, Ont.*, two miles east of *Ingersoll*. In company with another surveyor named *Gregg*, he was endeavoring to ascertain the height from the ground of the Hydro-Electric wires at *Uren's Corners*. The two men had taken an ordinary tape measure to get the height, and *Gregg* threw this over the wire, while *Baker* held the other end on the ground. Just as soon as the tape touched the wire *Baker* dropped, having received a large proportion of the 110,000 volts which the wire carried. Two Hydro-Electric men who happened to be passing in an automobile rendered assistance, one trying artificial respiration, while the other went for a doctor. Death had, however, been instantaneous.

INFORMATION FOR INVENTORS.

M ESSRS. Pigeon, Pigeon & Davis, patent solicitors, 71a St. James St., Montreal, report that 160 Canadian patents were issued for the week ending February 18, of which 102 were granted to Americans, 26 to Canadians, 11 to residents of Great Britain and 21 to residents of other foreign countries. Of the Canadians, who received patents, 11 were residents of Ontario, 5 of British Columbia, 5 of Quebec, 3 of Manitoba, 2 of Alberta and 1 of Nova Scotia. In the United States, for the same week, 819 patents were issued, 11 of which were granted to Canadian inventors.

MACHINE SHOP METHODS ^A_N^D DEVICES

Unique Ways of Doing Things in the Machine Shop. Readers' Opinions Concerning Shop Practice. Data for Machinists. Contributions paid for.

REPLACING BROKEN CHAIN ON A DRILL PRESS.

By S. G. Macklin.

YOUR issue of Feb. 20th contained an article on motor construction by D. A. Hampson which was particularly interesting, in that it called attention to the oversight of small and useful details in the design and construction of numerous completed machines: for instance, a drill press with an ordinary link chain, in which the weight is bottled up, so that it becomes necessary to take the machine apart to repair the chain. At a large manufacturing plant, it falls to the lot of some one to keep the various machines in repair, and in the case of broken chains, I wonder how the other fellows lift the weight.

When I first got into this work, the man in command conceived the idea that wire cable was superior to chain, consequently, this was installed in a number of instances. The result was, that the cable, moving over the comparatively small sheaves, soon broke. It was then usual for us to take a long hook with eyes at intervals and fish until we hooked something. Afterwards by some display of strength, we pulled the weight up, a little at a time. It is understood of course that the top of the drill press was moved over until we could get into the pillar.

Rising to the Occasion.

It has been said that if it were not for lazy men there would be no inventions and that it is only when a man tires of doing a certain thing in a certain way that he improves upon it. At any rate, after certain changes, and finding myself in the same position as the man who installed the cables, I introduced a candle on the end of a wire rod, with a view to throwing a little light on the subject. There was next requisitioned a small winch and chain, or block and tackle to lift the weight. This eliminated undue bodily strain and at the same time provided a sure means of holding the weight up. After the chain is repaired, a piece of stove pipe wire is useful to thread it over the sheaves, it being not very difficult to pass it up from the front over the top sheave, and keep poking until it come over the next. Should the drill press be one with a removable top, this wire can be slipped under and into the pillar more readily than twine or a larger section wire. By having a length of chain attached to an S link, so as to

insure the chain being long enough to reach from the weight all the way round, and then fastening on the wire and dropping the weight to the floor, the chain can be drawn up by the wire, and the weight lifted by the sleeve until the end of the chain is in position after the top is in place and fastened. The weight is held by slipping something through a link and allowing it to hang thereon; the whole process being a comparatively simple one.

When the chain is fastened to the arm, and passes through a sheave in the weight and up over the top sheaves to the sleeve, it means a lot of work to get that chain placed after it is repaired. The drill press must be unfastened from the floor and pulled over while something long enough must be threaded over the sheaves to reach clear through the pillar. Great care should be exercised to keep the chains straight. After the chain is placed and the machine set upright, it must be lined and leveled with as much care as setting up a new machine. All this work is necessary because there is not a hand hole near the top of the weight, therefore, why is not the pillar so designed that a hole could be placed in the side, large enough for a man's hand? Further, some drill presses are designed in such a way that they must be laid on their side and the bottom taken off to get at the weight. It is true that the chain does not break very often on each individual drill, yet it seems possible to do away with much of the tron-

ble and labor involved in accomplishing what actually need take only some fifteen minutes.

The easiest job of its kind that happened my way was when the largest weight in the shop went down. It went into the cellar. After the chain was repaired, we pulled it up through the same hole and it was soon done. The assistant foreman wanted to know how we got at that weight from underneath.



A DRILLING ATTACHMENT.

By H. R.

THE sketch shows a very useful drilling machine attachment, for use when holes have to be drilled that cannot be done on an ordinary drill press. The body (A) is of cast iron, bored to suit the phosphor bronze brushes (B), the ball races (C), and the phosphor bronze nut (D). A spigot is turned for locating the cast iron door (E), which is held in position by the screws (F). The gearing shown, is two to one, but any desirable centres may be adopted to suit circumstances.

The large wheel (G) is of mild steel and has the bearing pieces and taper shank all forged solid. The pinion (H) is keyed and pegged on to the shaft (I), which is of hardened steel with a taper hole for the drills. The machine can be made practically oil-tight, therefore, it can be filled with grease packing with advantage.

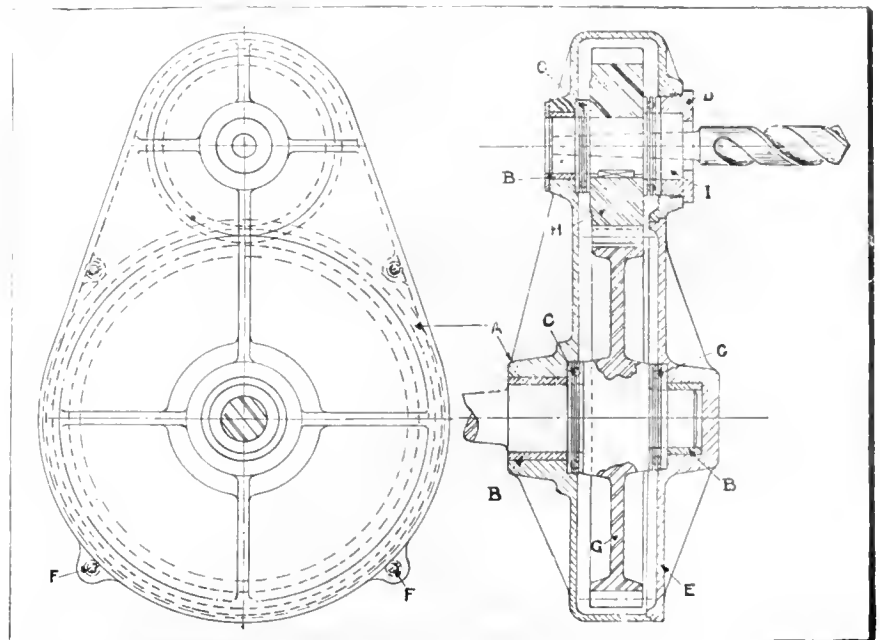

A DRILLING ATTACHMENT.

FIRST AID AFTER SHOCK.

HOW to save the life of a victim of electric shock is the subject of a chart and pamphlet issued by the Commission on Resuscitation from Electric Shock. This committee, of which Dr. W. B. Cannon, of Harvard, is chairman, represents the American Medical Association, the National Electric Light Association, and the American Institute of Electrical Engineers. A copy of the code of rules for resuscitation has been sent to every member of the three organizations.

The commission set out to solve three problems:—First, what course the layman should pursue who finds a person unconscious from electric shock; second, the invention of a mechanical device for artificial respiration, and, third, to investigate "the possibilities of restoring the fibrillating heart to its natural pulsation."

Device for Artificial Respiration.

The above mentioned set of rules is the answer to the first question, and Dr. S. J. Meltzer, of the Rockefeller Institute of Medical Research, has all but completed the invention of a device which has restored the respiration of cats and dogs. Tests on human beings are now being made.

Artificial respiration should be begun before any attempts are made to loosen the subject's clothing, although this may be done concurrently. The rules state that the artificial respiration should be continued without interruption for at least two hours, or until a doctor arrives, and no liquid should be introduced into the patient's mouth until he is fully conscious.

Some "First Aid" Rules.

The "first aid" rules direct the rescuer—first, to break the circuit without receiving a shock himself, this being done by a single quick movement. The rule on this point says: "Use a dry coat, a dry rope, a dry stick or board, or any other dry non-conductor, but beware of using metal or any moist material." The rescuer should use only one hand, if the aid can be practically so administered, and he is advised against touching the soles or heels of the victim's shoes while in contact, because of the nails in the shoes. Rubber gloves or rubber cloths form the best protection while handling a victim of shock, but if there is no time to get these, dry cloth will answer. If the victim is conducting the current to ground, and is convulsively clutching the live conductor, it may be easier to shut off the current by lifting him than to leave him on the ground and try to break his grasp. The quickest way to

break the circuit is by opening the nearest switch.

The actual method of resuscitation is the Schafer, or "prone pressure" method, and begins by laying the subject on his stomach, with arms outstretched in front of him. The rescuer kneels, straddling the victim's thighs, and facing his head.



QUICK METHOD FOR PUTTING SET SCREWS IN PULLEYS.

By James E. Cooley.

THE accompanying sketch shows a method for placing set screws in pulleys. The usual plan adopted is to turn them in the hub of the pulley by means of a wrench; but, since the arms of the pulley obstruct the movement of the wrench, the screw must be run in by half-turns.

A bushing (A) is broached out square on both ends, and one end is placed over the head of the screw, which has been started in the hub by hand. The end of

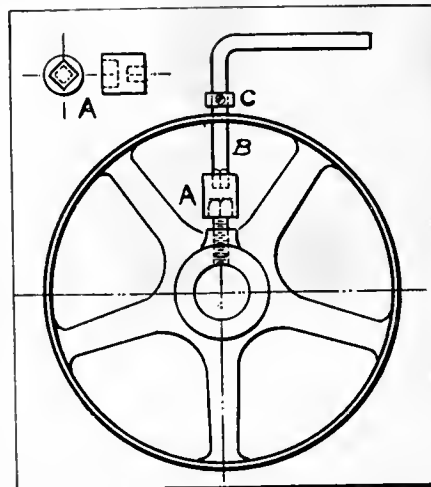

QUICK METHOD OF PUTTING SET SCREWS IN PULLEYS.

the rod (B), which is milled square, is inserted in the bushing by passing through the hole in the rim of the pulley, which acts as a guide. A few quick turns of the rod send the screw down to the shaft hole. The collar (C) on the rod acts as a stop for turning the screw down within one or two threads of the shaft hole, the pulley being then ready for assembly on the shaft.



SPIDERS CONTRIBUTE TO PANAMA CANAL CONSTRUCTION.

A NUMBER of spiders at the Gorgona shops are contributing their little share to the construction of the Panama Canal. They are carefully protected in the instrument room, because, from their cocoons, the instrument makers procure filaments for use in the transits of the surveyors. In the microscopes of

the transits are very fine threads by means of which the surveyor determines when his instrument is centred upon an object. This thread is of platinum when the instruments are new, but when it has worn out and must be replaced, the instrument repair men at Gorgona have been using the thread taken from the cocoon of a certain variety of spider which has been encouraged to multiply in the instrument shop for the past seven years. This use of the filament from the cocoon is of course not original on the Isthmus.

It has been found that when the instruments so repaired are used early in the morning or during a rain, the thread does not remain taut, because the instrument itself contracts. As soon as the instrument warms up, however, the spider web answers its purpose very well. In order that there may be no time of the day in which the transits may not be used, an order has been placed for platinum thread. When this arrives on the Isthmus, the use of the spider web will be discontinued, and the Canal force will be reduced by at least half a dozen more workers, for there are at least that many spiders spinning fiber at the Gorgona Shops.



WESTERN CANADA POWER.

THE long-delayed announcement of the signing of the 40,000 horse power contract between the Western Canada Power Co. and the British Columbia Electric Railway Co., has now been made. Upon the return of Mr. C. H. Cahlan, president of the former company, to Montreal last week, it was stated that arrangements had been completed and that the contract had received the endorsement of the boards of both companies. Under the agreement, 12,000 horse power is to be supplied by Western Canada Power Co. by the first of next September, and this amount is to be gradually increased until the maximum of 40,000 horse power is reached.

In order to supply the initial output of 12,000 h.p. it will be necessary to go right ahead with the power development at the upper level. This will mean the installing of two more units in the power house already erected, and the doubling of capacity from 25,000 to 50,000 h.p. The present two unit installations of 25,000 h.p. is practically all contracted for, and a great part already connected up. For supplying the ultimate load of 40,000 h.p. the lower level water power will have to be utilized, which means the starting of work in the no distant future. This will bring the output of the Western Canada Power Co. up to 100,000 horse power.

DEVELOPMENTS IN MACHINERY

A Record of New and Improved Machinery Tending Towards Higher Quality and Economical Production in the Machine Shop, Blacksmith Shop or Planing Mill.

DOUBLE SPINDLE RING WHEEL GRINDER.

ILLUSTRATION shows an improved double spindle grinder recently placed on the market by Charles H. Besly & Co., Chicago. It is known as their No. 6-18 inch ring wheel grinder, and its purpose, that for grinding two parallel sides of work simultaneously. The design is specially heavy and rigid for hard continuous service by manufacturers of wrenches, etc. Extra heavy spindles and extra long bearings for carrying vitrified grinding rings held in suitable steel chucks, are features of this machine. The heads are mounted on V-ways planed on the bed casting, that to the

ings ground over the outside, split and carefully fitted into bored and reamed holes in head castings. The bearing bushings are of cast iron, lined with high grade bearing metal, and both of those on the right hand spindle slide with the spindle and completely ease it.

By limiting the endwise movement of the sliding spindle to one inch, a desirable end has been attained; namely, that the grinding wheel on this spindle is always near to and rigidly supported by the head casting. The end thrust on each spindle is taken between pulley and outer bearing bushing, on a hardened and ground tool steel thrust collar

struction of the pressed steel ring wheel chuck is such that by means of a small hand hole at each end of the telescoping dust hood, the grinding ring may be set out and re-clamped without removing the ring wheel chuck from spindle. The spindles are 2½ in. diameter and run in bearing bushings totalling 37 in. in length. The geared lever feed on sliding spindle gives the operator a leverage of 20 to 1 so he may force the machine to the limit of its driving power without undue muscular exertion.

The height of the machine to centre of spindle is 40 inches, while the bed casting at floor measures 24 in. x 58 in., and under the heads, 14 in. x 64 in.

The weight of machine complete with two 18 in. helmet pressed steel ring wheel chucks, grinding rings and counter shaft is 3,500 lbs. When equipped with four 20 in. steel disc wheels and cementing press, instead of the ring wheel chucks, the total weight is 4,100 lbs.

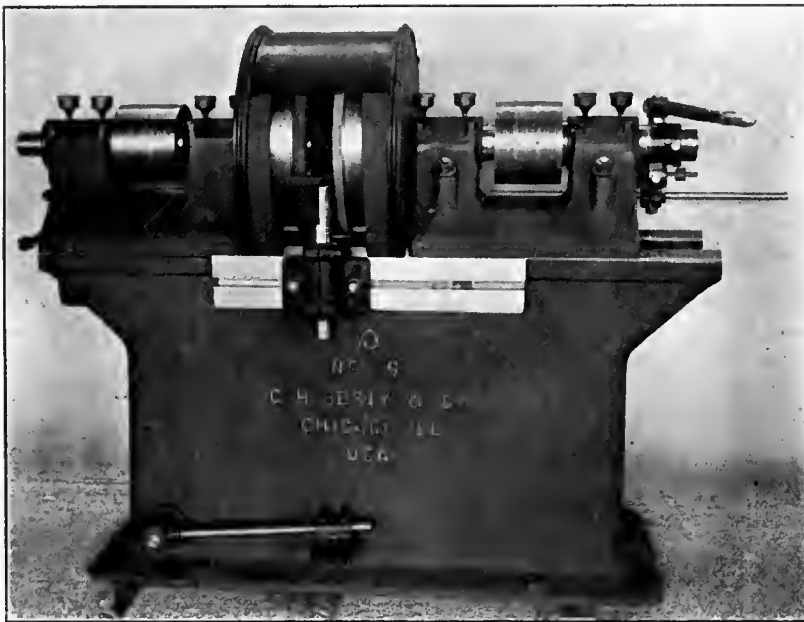

DOUBLE SPINDLE RING WHEEL GRINDER.

left being stationary, and bolted rigidly on the ways, while the head to the right can be moved along the bed and clamped to grind any desired length within the capacity of the machine.

To bring the grinding wheels in contact with the work, the spindle of the right hand head has an endwise movement of one inch. This movement is actuated by both a hand and a foot lever, operating through a pinion engaging a rack cut on the outer right hand bearing bushing. The longitudinal movement is limited inwardly by an adjustable micrometer stop screw, graduated to read to .001 in., so that work may be ground accurately to size and duplicated. The spindles run in inserted bearing bush-

ings of larger area, and the end play of spindle is controlled on outer bearing bushing by adjustable keyed collar of phosphor bronze held in place by a lock nut at end of spindle.

The machine is equipped with an automatically telescoping dust hood, hinged at back to give free access for changing grinding wheels, and has air-tight connection at back of machine for exhausting the grindings. Spindle and thrust bearings are lubricated by solidified oil from compression oil cups, oil grooves being so placed that oil is positively forced where it is needed. Movement of the solid oil is always outward which prevents grit entering and cutting bearings. A desirable feature is the fact that con-

SKEFKO SELF-ALIGNING BALL-BEARING.

THE success which has attended the introduction of the Skefko Self-Aligning Ball Bearing is witness to its practical value, and to the adequacy, in service, of its special features. Although the bearing is novel in its design, it is, none the less, so simple that the whole of its features may be appreciated after a few minutes' inspection of a sample, and there will be no difficulty in understanding its construction from the illustrations. Fig. 1 is a perspective view of a Skefko radial bearing of ordinary type; Fig. 2 a perspective view of a Skefko thrust-bearing, partly disassembled; Fig. 3 a cross-section through half of the radial bearing, and Fig. 4 a section through a combination thrust and radial bearing fitting. Confining our attention for the moment to the ordinary radial Skefko bearing, as shown in Figs. 1 and 3, it will be seen that the arrangement consists of a ridged inner race carrying two rows of balls which work against an outer race, the surface of which forms part of a sphere. The balls are held in position and their pitch is maintained by a solid metal cage, which can be very clearly seen in Fig. 1, and is shown in cross-section in Fig. 3.

Ideas Underlying the Design.

The first main idea underlying the

design of the bearing has reference to the fact that the spherical outer race allows the inner race and balls to swivel out of their plane of rotation, so that they are capable of adjusting themselves to any out-alignment of the shaft owing to bending or bad erection. The value of this feature is recognized in ordinary ball-bearings, which are so

greatly increases the capacity of the Skefko bearing, and renders it capable of dealing successfully with very heavy loads.

A third feature of the bearing which should be mentioned, and which also has relation to the heavy loads which it can carry, turns on the areas of contact between the balls and the races. In an

two races are the same. The radii of the inner race are a little greater than the radii of the balls, although this is not shown very clearly in Fig. 3.

Load Carrying Features.

It is probably hardly necessary to refer in further detail to the main features of the bearing, although it is perhaps well to point out that any load on the bearing must be taken equally by the three top balls, as they are at the corners of an equilateral triangle. Also that any such load is transmitted through the centre of the balls directly to the centre of the bearing, since the radius of the outer race is struck from this centre of the bearing. The tangents at the points of contact of any ball with the races are always at right angles to the line joining the centre of the ball to the centre of the bearing, so that there is at no time any outward thrust on the balls due to the load. At the same time, however, the bearing is capable of taking a certain amount of end-thrust, owing to the ridged inner race and the spherical outer one. The inner race and balls are capable of slewing completely round in the outer race, and at the same time maintaining proper contact with it. The example illustrated in Fig. 1 is shown with the balls and inner race moved round through a large angle.

It is claimed by the makers that Skefko ball-bearings are not only capable of performing very heavy duty as a result of their design, but also in virtue of the material of which they are made and the accuracy of their construction. Both balls and races are made of Swedish charcoal crucible cast steel, the balls being formed by a die-

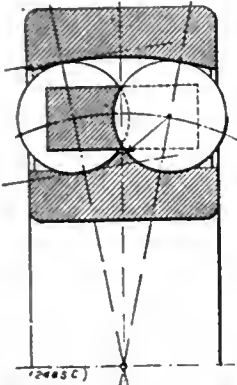

FIG. 3. SECTION THROUGH HALF OF RADIAL BEARING.

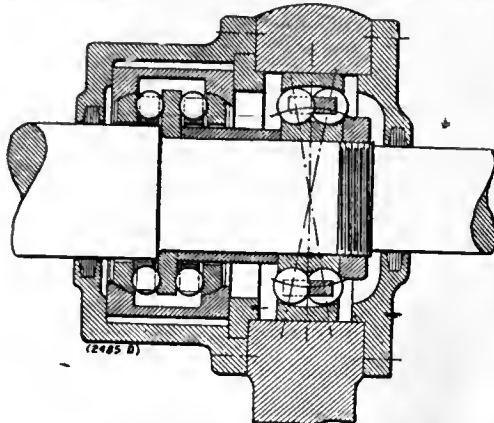

FIG. 4. SECTION THROUGH COMBINATION THRUST AND RADIAL BEARING FITTING.

frequently mounted in swivelling housings, but the advantage of having the feature inherent in the bearings themselves is obvious, more especially as the swivelling, of course, takes place on balls instead of on a solid bearing, so that even in extreme conditions, with a badly bent shaft, or one somewhat light for the work in hand, the loss in friction due to the swivelling is extremely small.

The second idea underlying the design is that, owing to the two rows of

ordinary ball-bearing the areas of contact between the balls and the outer race are greater than those between the balls and the inner race. This is due to the fact that, in the plane of rotation, the outer race is concave towards the balls in contact with it, but the inner race is at the same time convex. The effect of the unequal contact areas is that undue wear takes place on the inner race, and at the same time unequal strains are set up in the balls, leading sometimes to fracture. In the

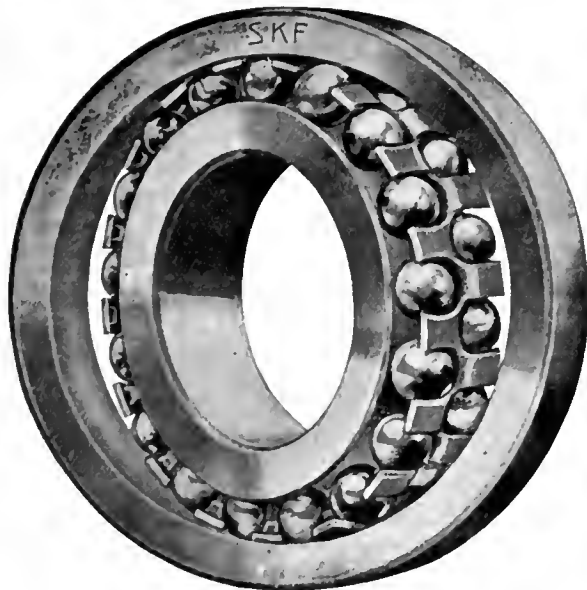

FIG. 1. PERSPECTIVE VIEW OF SKEFKO RADIAL BEARING, ORDINARY TYPE.

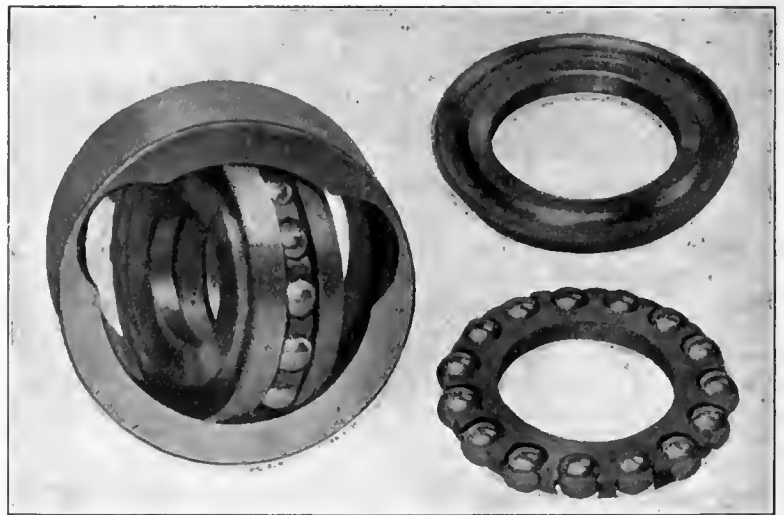

FIG. 2. PERSPECTIVE VIEW OF SKEFKO THRUST BEARING, PARTLY DISASSEMBLED.

balls, the load is at any instant taken on three balls, situated at the apices of a triangle, instead of on a single ball, as in an ordinary bearing. This feature

Skefko bearing, however, these unequal areas do not exist, since the radii of curvature of the ridged inner race are taken so that the contact areas with the

forging process, instead of being turned from a bar, so that they receive much working in course of manufacture and are of quite exceptional strength when

completed. The races are turned from bar and hammered blanks, and are hardened and tempered in a special plant before grinding. The grinding is, of course, one of the most important operations in the manufacture of the races. It is done on machines specially designed for the operation, and carrying rotating carborundum wheels at the ends of oscillating arms. The pockets in the cages are proportioned to hold the balls quite loosely, but, at the same time, prevent them falling out by their own weight. A race with its balls may be handled as a complete unit, without fear of losing the balls, and, at the same time, any ball may easily be sprung out of place by prising it from behind, if it is desired.

The Skefko Thrust Bearing.

The thrust bearing, shown in Figs. 2 and 4, although not a main feature, is yet of much interest in itself. The bearing shown has a double row of balls, but both double and single-row thrust-bearings are manufactured. The balls are carried in a phosphor-bronze cage, and the races and housing are turned from crucible cast steel and ground. The three races making up the bearings are turned so that their outer surface forms part of a sphere, which is capable of rotating in any direction in the housing to allow for lack of alignment. The disassembling of the bearing is allowed for by two slots made in the housing, which can be seen in Fig. 2. By swinging the races with their balls out of their plane of rotation until one of the end races comes opposite these slots, it is possible to remove this race, and after it, the first set of balls with their cage. The bearing is shown with these two parts removed in Fig. 2. The remaining parts may, of course, be removed in the same way, while individual balls may be sprung out of their cage exactly as in the ordinary bearing previously described.

Skefko Self-Aligning Ball Bearings are of Swedish origin, and manufactured in England. At the recent Toronto Motor Show the Canadian Fairbanks-Morse Co., representatives for Canada of this specialty, had several examples on exhibition.



THE ALLEN SAFETY HOLLOW SET SCREW.

THE Allen safety hollow set screw was designed primarily to eliminate the risk of personal injury which is inseparable from the use of the ordinary square or hexagon-headed set screw. As may be seen from the cut, it is hollow inside, the centre being a hexagonal recess, into which a bent steel

bar of corresponding size is introduced as a wrench.

The Allen hollow set screw is made from plain cylindrical stock, and not cupped from a disc. It is highly finished in every way, and is intended fully as much for use in machine construction as for overhead work. It is especially useful for replacing flush-headed screws driven by a screwdriver, the fact being well known that the latter cannot be screwed up really tight. If the screw is of soft steel the slot is liable to burr over, and if the steel is hard, the edges of the slot chip off. It is safe to say that the day is not far distant when the slotted head screw will be a thing of the past in machine construction.

For ordinary purposes the Allen safety hollow set screw is made in two lengths for each size, except in the case of the 9-16in. and 1/4in. sizes. The screw generally used has a length equal to its diameter, this being ample for



THE ALLEN SAFETY HOLLOW SET SCREW.

most purposes. For parts subject to much vibration the longer screw is, however, recommended; hence the reason for stocking two lengths. The great strength of the Allen set screw has frequently been demonstrated. We ourselves recently saw one of 1-inch diameter screwed home tight into a blind hole with all the force a mechanic was able to apply at 20 inches leverage, and upon withdrawal it appeared to be in as perfect condition as before the test.

The Allen Manufacturing Co., Inc., of Hartford, Conn., hold patents on this set screw in the leading countries of the world. The Canadian market is supplied from a well-appointed factory situated at 29 St. David's Lane, Montreal, where a large stock from 1/4in. up to 1in. inclusive is always carried.



ADDING TO PLANT.

THE Niagara, St. Catharines & Toronto Electric Railway is adding considerably to its plant. A 750 K.W. rotary converter and transformer, for the Niagara-on-the-Lake extension, which is being graded now, was recently received, and orders have been placed for two 500 K.W. rotary converters and transformers, which will make available at St. Catharines, 1,000 K.W.; Thorold, 1,000 K.W.; Niagara Falls, 600 K.W.; Welland, 500 K.W.; and Niagara-on-the-Lake, 750 K.W. Four new Brill con-

vertible double, four-motor cars have been ordered. The expenditures will total about \$100,000.



BRITISH AUTOMOBILE ENGINEERS TO VISIT UNITED STATES.

A JOINT party of the Institution of Automobile Engineers and the Society of Motor Manufacturers and Traders will leave St. Pancras Station, London, by train at 8.30 a.m. on Saturday, May 17th, for Tilbury, where they will join the T.S.S. Minnewaska, of the Atlantic Transport Line, which will leave Tilbury about 10 a.m. for New York.

The visit will conclude officially at Buffalo on the afternoon of Tuesday, June 10th, when those who wish can return to New York and catch the Cunard S.S. Mauretania, which leaves New York at 1 a.m. on the morning of June 11th, or the White Star S.S. Baltic, which leaves on the 12th.

The reason for an American visit is as follows:—In response to the invitation of this Institution, the Society of Automobile Engineers of America sent a party of about sixty members to visit the Olympia Show in 1911, and this party was entertained by the Institution, and also visited a number of works throughout the country. Before the American visitors returned home, it had been arranged definitely that, in response to their invitation, an endeavor would be made to organize a party of British engineers to join the Society of Automobile Engineers in its summer meeting at Detroit in the present year. Correspondence on the matter has been continuous between the secretaries of this Institution and the Society, with the result that the following programme has been mapped out:—

Saturday, May 17th, leave London, as above stated; Monday, May 26th, arrive New York; Monday and Tuesday, May 26th and 27th, in New York; Wednesday, May 28th, leave New York for Pittsburg; Thursday, May 29th, in Pittsburg; Friday and Saturday, May 30th and 31st, in Indianapolis; Sunday, Monday, Tuesday, and Wednesday, June 1st, 2nd, 3rd, and 4th, in Detroit; Thursday, Friday, and Saturday, June 5th, 6th, and 7th, lake trip on steamer (Society of Automobile Engineers, summer meeting); Sunday and Monday, June 8th and 9th, in Cleveland; and Tuesday, June 10th, in Buffalo. Here the party will be divided, and those who wish may return direct to New York. The remainder will proceed to Providence on Wednesday, June 11th, to Bridgport and Newhaven, on Thursday, June 12th; and to Hartford, Friday, June 13.

FOUNDRY PRACTICE AND EQUIPMENT

Practical Articles for Canadian Foundrymen and Pattern Makers, and
News of Foundrymen's and Allied Associations. Contributions Invited.

ANNEALING STEEL CASTINGS.

THE most important purpose of the annealing operation should be to break down entirely the large inter-crystalline boundaries, thereby permitting the crystals to re-form under more favorable conditions during the subsequent cooling. After this treatment, the material so far as structure alone is concerned, may be compared to an over-heated forging, the very coarse crystalline structure having disappeared. Fragility tests give high and quite concordant results, and the fractured surface is no longer to be distinguished in appearance from that of a cogged billet. If the castings are heated only to low redness, the typical structure is only partially obliterated and the shrinkage stresses relieved, but the crystalline grains are little if any smaller, and their internal structure still bears some resemblance to the original.

Annealing is also desirable for another reason quite independent of shrinkage stresses. The interior surface of a sand mold generally contains carbonaceous matter, either in the molding material or as plumbago, paint, etc. The hot steel, coming into contact with this carbon, or the gases that arise from it, is hardened the action of cementation being more marked in those places from which cracks can most easily be started. As the bulk of the metal may contain less than 0.3 per cent. of carbon, the surfaces that have been in contact with the mold may contain as high as 1.5 per cent. carbon, on which account, the castings are of inferior quality unless the difficulty is corrected by suitable annealing. The hard exterior of an unannealed casting may possess some commercial value as a wearing surface, where the shape is extremely simple.

Difficulties and Complications.

During the many hours that the casting is exposed at high temperatures to the oxidizing temperature of an annealing furnace, the carburized envelope disappears and is replaced by an envelope of carbonless metal, which is accompanied by a re-arrangement of the internal crystalline structure. Considerable doubt exists as to whether castings of delicate structure and complex outline, can be kept to shape at the high temperature required to break down the coarse primary structure. Difficulties of this kind must be overcome separately as they occur. There are, however, some-

times hindrances in the steel itself of a very serious nature which can, according to certain authorities, be overcome, but not by any method of heat treatment at present known. This is the presence in special form, of non-metallic impurities, which may be grouped under the head of slag enclosures. In the mass of a casting such enclosures here and there, may not prove serious, in fact few large castings or forgings are entirely free from these blemishes, but in a test bar they would spoil the results absolutely. What is more serious than the segregated slag area, because more wide-spread is the tendency under certain conditions for envelopes of non-metallic impurities to form around the crystalline grains. These always weaken crystalline cohesion and are difficult to deal with. A slag globule within the primary crystal is comparatively harmless. When, however, the slag forms as a film between the grains, it is not easy to set a limit to the troubles that follow, as a very slight disposition to pull, when the casting contracts, results in the formation of a crack.

It has been stated that films or silico-sulphide streaks, as they are some times called, will ball-up when annealing the casting; but the examples the author has seen were unfortunately not of that variety, and it may be seriously doubted whether the balling-up of an actual film has ever been accomplished by any form of heat treatment which a casting might be expected to survive. Having located between the primary crystals, the films persist as films. As often as the casting may be heated, the films remain, and during the subsequent cooling, act as nuclei around which the free ferrite gathers as it falls out of the solution.

OPPOSE STEEL TRUST TOWN.

IF the Ontario Government grants a city charter to the United States Steel Corporation, which has bought 1,650 acres in Sandwich, near Windsor, with the object of establishing a large steel plant and incidentally a town, to be known as the town of Pontiac, the District Trades Council of Toronto fears the employees of the steel corporation will be no better off than slaves, owing to the system of government which, it is feared, might be established.

At a meeting of the Council on Thursday, March 6, the delegates unanimously

instructed the secretary to communicate with the Ontario Government, and urge them to withhold a charter from the steel corporation. The bill respecting the proposed plant and town of Pontiac is now before the Legislature and has been given its first reading.

NICKEL-BRONZE MIXTURE FOR HYDRAULIC CASTINGS.

THE production of bronze castings to stand hydraulic pressure is a matter which often perplexes a brass founder. He may be able to make good castings and those which have a fine surface, but when the castings are tested, leakage results. It has been found that a special mixture is better for hydraulic castings than the ordinary composition or the well-known 88-10-2 bronze. A casting which has a good superficial appearance may not stand the pressure, and for this reason, a mixture which has the necessary closeness of grain is required.

It is not a question of tensile strength in the castings, as this has been found less important than the grain of the metal; and the patterns will be found of sufficient thickness to stand the pressure. Those who design such patterns know well that there is nothing to be gained in making the walls too thin, and it is invariably the ease that a sufficient thickness is given them. The problem, then, is one of mixture and good foundry practice. Even with the mixture herewith given, poor foundry work cannot be tolerated.

The following mixture for making hydraulic castings has been in use for some time in one of the large foundries in the United States, and has proven very satisfactory for this purpose. It has been used on castings which had to stand 3,000 lbs per square inch hydraulic pressure, and for this purpose was found satisfactory. The mixture is as follows:

Copper	83 lbs.
Tin	5 lbs.
Zinc	5 lbs.
Lead	5 lbs.
Nickel	2 lbs.

The nickel in the mixture is the metal that produces the good qualities for hydraulic work. To make the mixture, the nickel should be put into the crucible with a small amount of the copper, and the two melted together. Make sure

the nickel is melted and kept well covered with charcoal while the melting is going on, then add the rest of the copper, and melt in the usual manner, afterwards adding the zinc, tin and lead. Stir well in order to thoroughly mix the ingredients. The metal is poured at about the same temperature as composition.—Brass World.



FROM A BANKER'S VIEWPOINT.

THE Canadian Bank of Commerce Review of Business Conditions in Canada during 1912 says:

"Manufacturing of all kinds has reflected the excellent business conditions prevailing everywhere in Canada, and, without exception, the mills, in many instances recently enlarged, have been fully employed at remunerative prices. The steel works at Sydney and New Glasgow, now national enterprises of great importance, have had full employment for considerably enlarged plants. They encountered serious competition from the United States early in the year, but this situation improved later on, enabling both companies to increase their prices to a more profitable level, and, from the present outlook, this condition of affairs is likely to continue for some time to come.

"In general business it has been a year of uninterrupted success, with a reasonable expansion in all lines, but without any signs of overtrading and with no considerable business failures. Labor has had no interruption from strikes or other causes, and the earning power of the population, especially that of the skilled workman, has more than kept pace with the increased cost of living. Debts were satisfactorily discharged and general conditions were never better."



OIL LOCOMOTIVE FOR CHILE.

SOME interesting engineering problems were involved in an order placed recently with the C. W. Hunt Co., West New Brighton, N.Y., for a locomotive for haulage in Chile in connection with the nitrate mining industry. The supply of bituminous coal in this region is limited, and the water, which is also scarce, has a large content of mineral salts. The track for which the locomotive was designed is a narrow one, 30in. gauge, with many sharp curves and grades which require a large tractive effort in the locomotive. Crude oil is plentiful in the neighborhood, and can be obtained for about 3 cents a gallon. This fact led to the proposal, after all the controlling factors were taken into consideration, to build a car in which a crude oil engine would be used to drive a generator to supply cur-

rent to two motors, which in turn were directly connected to the four axles, through driving chains and reducing gear.

The Motive Power.

The motive power is supplied by a vertical three-cylinder, two-cycle internal combustion engine rated at 75 h.p. and operating on crude oil. The cylinders are 10in. diameter and 12in. stroke, and ignition is effected by the hot ball method. Compressed air is used to inject the fuel into the chamber at the end of the compression stroke, and provision is made for feeding the steam generated in the water jacket into the combustion chamber with the air supply. The engine is connected to the generator through a flexible coupling, which absorbs any small discrepancies in the alignment of the engine and generator shafts.

A special feature of the engine is the automatic compressed air starting device, consisting of a chain-driven valve which provides a passage for the compressed air into the three cylinders in proper sequence, in whatever position the engine may happen to be at starting. The air is furnished by a small compressor attached to the rear cylinder and operated directly from the main shaft of the engine through an eccentric. This compressor automatically maintains a constant pressure of 175lb. per sq. in. in the storage tank at the back of the engine.

The Generator.

The generator used is a 40-kw. multipolar direct-current machine, and supplies current at 125 volts when running at its normal speed of 340 r.p.m. The current is delivered to two direct-current 25 h.p. motors, each of which is connected to the two axles of its truck through a chain belt and speed-reducing gear working in an air-tight oil-filled gear case. A switchboard is provided directly in front of the engine, and on it are placed the usual meter and switch arrangements for taking readings of current and voltage on the electrical units. The controller furnished is of a special series-parallel reversing type, in which the series-parallel contacts are made on an auxiliary drum. This arrangement allows the motors to be put directly across the line in either series or parallel relation without the use of external resistance, and it provides for nine speeds forward and reverse, permitting starting, stopping, and reversing at will.

The brakes are of the hand-operated post type, in which brake blocks, lined with a special mineral-tanned leather designed to resist high temperatures, are applied to the outer periphery of 10in. brake wheels, one on each motor

shaft. Dust-proof roller bearings are used for the axles, and these proved to be so nearly frictionless that the complete car, weighing 22 tons, could easily be pushed along a level track by one man before the chain-driving belts were attached. Three metal storage tanks, 102in. long and 15in. diameter, are placed under the locomotive frame, of which two are for water and the third for oil.



INSPECTION OF STEAM BOILERS.

IT becomes apparent from a new clause found in the Act regarding the inspection of steam boilers, that the Ontario Department of Agriculture no longer purposes to run this inspection system at a loss. The Hon. Mr. Duff's new bill proposes, first of all, to make boilers uniform throughout the Dominion, but the second interesting feature of the bill is that inspectors are to be allowed to make a charge of \$5 for every boiler which they inspect, and a further clause makes any manufacturer or owner who refuses to comply with this fee open to penalty of \$20.

Almost arbitrary powers are to be given the inspectors, the bill stating that they may enter a manufacturing plant at any hour for inspection, and any person who refuses them admittance makes himself liable to a fine. As there are many thousands of such boilers in the Province, there will, doubtless, be a big revenue from inspection, if the bill passes. It is noted that no provision is made to determine how many times a year an inspector may go over the plants where boilers are installed.



BRITISH ENGINEER'S VISIT.

WITH the arrival of Sir John Jackson, president of the Sir John Jackson Construction and Engineering Co., of London and Canada, at Montreal last week, rumors were started as to the probable business which brought him to this country. He is one of the most noted of British engineers and contractors, some of the work which he has undertaken and carried out being world famous.

The Sir John Jackson Company have a contract of two million dollars for improved harbor facilities at Victoria, B.C., and they were the only firm to tender for the Dry Dock to be constructed at Levis, P.Q. Rumors in circulation are to the effect that he was in Montreal in connection with the new tunnel which it is proposed to build under the St. Lawrence to the South Shore, and credence was given this rumor by the fact that the Company's men were engaged in making surveys of this work some months ago.

The MacLean Pub. Co., Ltd.

(ESTABLISHED 1888.)

JOHN BAYNE MACLEAN - - - - - President
H. T. HUNTER - - - - - General Manager
PUBLISHERS OF

CANADIAN MACHINERY AND MANUFACTURING NEWS

A weekly newspaper devoted to machinery and manufacturing interests, mechanical and electrical trades, the foundry, technical progress, construction and improvement.

H. V. TYRRELL - - - - - Business Manager
PETER BAIN, M.E. - - - - - Editor
J. H. WILLIAMS - - - - - Associate Editor

OFFICES:

CANADA	GREAT BRITAIN
Montreal, Rooms 701-702 Eastern Townships Bank Bldg.	London, 88 Fleet Street, E.C. Phone Central 12960 E. J. Dodd
Toronto, 143-149 University Ave., Phone Main 7324	UNITED STATES
Winnipeg, 34 Royal Bank Bldg., Phone Garry 2313	New York, R. B. Huestis, 115 Broadway, New York, N. Y., Phone 2209 Rector
Vancouver, H. Hodgson, 2640 Third Ave. West.	Chicago, A. H. Byrne Room 607, Marquette Bldg. 140 S. Dearborn St., Chicago
CABLE ADDRESS:	
Macpubco, Toronto.	Atabek, London, Eng.

SUBSCRIPTION RATE:

Canada, \$2.00; United States, \$2.50; Great Britain, Australia and other colonies, 8s. 6d. per year; other countries, \$3.00. Advertising rates on request.

Subscribers who are not receiving their paper regularly will confer a favor on us by letting us know. We should be notified at once of any change in address, giving both old and new.

Vol. IX. MARCH 13, 1913 No. 8

PRINCIPAL CONTENTS.

The Motor Truck Feature at the Toronto Automobile Show	253-255
General	255
Power Sites in British Columbia...Large Gas Engines.	
Comparison of Motor Driven with Horse Drawn Vehicles	256
General	257-258
Furnaces for Tool Steel...Some Notes on Grinding...Care and Lubrication of Air Compressors...Leather Belt Data...Combines Aid to Industry...3,000-Ton Testing Machine...Electrical Firm Expands...Trade Disputes Show Decreases.	
Factors of Scientific Management Other Than Labor	259-260
The Question of Low Grade Fuel for Motor Trucks	260-261
Interesting Example of Bench Lathe Utility	261-263
General	263
The Age of the Business Man...Increased Mineral Output.	
Recent Judicial Decisions	261
General	264
Combined Sprinkler and Heating System...Test of Large Voltage Oil Circuit Breakers...Electrocuted in Odd Way...Information for Inventors.	
Machloe Shop Methods and Devices	265-266
Replacing Broken Chain in a Drill Press...A Drilling Attachment...Quick Method for Putting Set Screws in Pulleys.	
General	266
First Aid After Shock...Western Canada Power...Spiders Contribute to Panama Canal Construction.	
Developments in Machinery	267-269
Double Spindle Ring Wheel Grinder...Skefko Self-Aligning Ball-Bearing...The Allen Safety Hollow Set Screw.	
General	269
British Automobile Engineers to Visit United States...Adding to Plant.	
Foundry Practice and Equipment	270-271
Annealing Steel Castings...Oppose Steel Trust Town...Nickel Bronze Mixture for Hydraulic Castings.	
General	271
From a Banker's Point of View...Oil Locomotive for Chill...Inspection of Steam Rollers...British Engineers' Visit.	
Editorial	272
Industrial and Construction News	273
Engineering...Electrical...General Industrial...Municipal...Railways...Bridges...Waterworks...Woodworking...Building Notes...Marine...Tenders...Contracts Awarded...Personals...Trade Gossip...New Incorporations.	
The General Market Conditions and Tendencies	276
Selected Market Quotations	278-279

THE DESIGNER'S RELATION TO HIS COMPLETED WORK.

IN the layout of manufacturing and power plants, considerable pains are usually taken to secure the services of an expert conversant with the particular nature of the scheme. Betimes, and perhaps more often than conducive to the best results, the factory staff perform the work, in which case, a more or less affected superiority of intelligence over that of any expert is generally given opportunity of parade. This latter feature is referred to at this juncture because of its connection with, and the possible advantage it confers, relative to our subject.

We are right in saying that when outside help in the nature of an expert to lay out a plant is called in, and when the work is completed, it may be reckoned as his masterpiece, at least to the extent to which his freedom of action and his command of expenditure—legitimate, of course, has been determined. His interest in the work, however, ceases with the payment of his fee, a more or less unfortunate circumstance, as it appears to us. Let us say at once that we are not touting for the opening up of a new field of employment for consulting engineers or architects; it being our purpose rather to draw attention to an equally mutual advantage likely to accrue, were the individual or company responsible for the professional work, retained to supervise and oversee the equipment during a stated period of operation. Although, as we have said, the finished layout may be described as a masterpiece, it needs no stretch of imagination, to form an opinion that even previous to the plant going into regular operation, a large number of improvements begin to suggest themselves. Such being the case, we would naturally look for a further list of failings to show when the wheels begin to go round, or when the handling and transportation of a particular product in process of manufacture comes to be scrutinized with the microscopic investigation of efficiency. At this stage the designer is usually no longer in the employ of the proprietors of the plant, and, perhaps, as a consequence of some unfortunately aggravated trouble having developed in operation, more or less strained relationship exists. In either circumstance, and on both sides, there is loss besides that of prestige, so far as the expert is concerned, and loss of time or product so far as the manufacturer is interested. Were it the rule that an engineer, engaged to design and lay out a plant, had the opportunity to continue to oversee his handiwork, there would not only be less dissatisfaction with services rendered, but on the contrary, a large degree of enhancement given to the profession for future application, if not in the same plant or the same company's plant elsewhere, at any rate on the equipment of others projected.

Plants laid out by the staff of the proprietor are as a rule not only more costly, but generally less satisfactory in operation results than those handled by a man who makes the particular feature his specialty. This condition of things is largely due to the plethora of advice, and the opportunity afforded individual employees to put forward some more or less useless and harebrained idea and have it adopted, simply because they happen to have more authority than knowledge or intelligence. We do not presume to say that ideas put forward by those directing or operating a plant are all and always valueless, but we do say that the great majority of them come under this category, and while their sponsors are perfectly justified in having them put forward, we maintain that, in the circumstance of an expert being employed, no undue pressure should be exerted to have him incorporate suggestions so given, against his own better judgment.

INDUSTRIAL ^A_N^D CONSTRUCTION NEWS

Establishment or Enlargement of Factories, Mills, Power Plants, Etc.; Construction of Railways, Bridges, Etc.; Municipal Undertakings; Mining News.

Engineering

St. Catharines, Ont.—\$10,000 damage was done on March 9 to the brass foundry of the McKimmon Sash and Metal Co. by fire.

St. Thomas, Ont.—The city has been granted permission by the Ontario Legislature to issue debentures for the loan of \$15,000 to the Erie Iron Works.

Leaside, Ont.—The C. N. R. shops, which are planned, will employ 2,000 men when in operation. Other factories have secured sites of this C. N. R. subdivision, which will employ 400 men.

Medicine Hat, Alta.—The Medicine Hat Radiator Co. will erect a foundry to employ 60 men, to be increased to 100. L. Carey Wright, Sank Centre, Minn., is the head of the concern. About \$100,000 will be spent.

Victoria, B.C.—A \$22,000 contract was let a few days ago for the erection of the first unit of the big plant of the Dominion Safe Company, located just across the Lulu Island bridge in Richmond, B.C., near Ebwine. This concern

has a manufacturing site covering 10 acres on the waterfront and the B. C. Electric Railway, and proposes to expend \$10,000 in erecting and equipping its plant for the manufacture of safes and locks.

Electrical

Aylmer, Que.—The town contemplates the provision of an electric plant, costing \$25,000.

Wingham, Ont.—A duplicate electric generator, costing \$6,000, will be purchased by the town.

Sackville, N.B.—The city is contemplating the purchase of an electric light plant here for \$70,000.

Dundas, Ont.—The Water, Light and Power Commission contemplate purchasing a synchronous motor. Chairman, R. W. Karch.

Goderich, Ont.—The work of planning the Hydro-Electric transmission system through the town has begun. The line may be extended to Saltford.

New Westminster, B.C.—The Westminster Power Co., Ltd., will generate electric power from various waters in the district. Gordon E. Corbould, president.

The Dryden Timber & Power Co., Dryden, Ont., have recently installed a 1,000 h.p. three-phase generator, driven by a Francis turbine. The generator was supplied by the Lancashire Dynamo & Motor Co. of Toronto. Chapman and Walker were contractors for the electrical supplies.

General Industrial

Hamilton, Ont.—Fire did \$1,200 damage to Riordan's plating works on Thursday, March 6.

Duncans, B.C.—The Duncan Creamery Co. contemplate erecting a new plant at once.

Montreal, Que.—A factory, to cost \$70,000, will be built for the Consumers' Cordage Co., 283 St. Patrick Street. Architects, Ross & MacDonald; general contractors, C. E. Deakin.

C.P.R. MACHINE TOOL EQUIPMENT REQUIRED

The Canadian Pacific Railway Co. have issued specifications for the supply of the following machine tool equipment:—

2 frog and switch planers and 2 drilling machines, for their Angus shops.

1 drill, 2 power presses, 1 lathe, with 50 h.p. motor; 1 cutter and reamer grinder, 3 iron shapers, 1 stud lathe, 1 key slot miller, 1 milling machine, 1 boring mill, 2 brass lathes, 7 engine lathes, 1 gear wheel cutter, 1 twist drill grinder, 2 radial drills, 1 band saw, 1 ramming moulding machine, 1 bolt threader, plate rolls, 1 rivetter, 1 planer, 40in. band saw, 1 vertical drill, 1 vacuum cleaner for cushions, 1 1,800 lb. hammer, 1 1,500 lb. hammer, 1 80 lb. hammer, 1 bulldozer, 1 turret lathe, and 1 flanging press, for their Winnipeg shops.

1 electric winch, 1 boring mill, punch shears, 1 mortising machine, and 1 upright drill, for Fort William.

1 pipe threader and 1 rip saw machine, for Kenora.

1 30in. drill for Winnipeg coach yards.

1 800 lb. steam hammer for Brandon; 1 emery grinder, 1 30-in. drill, and 1 lathe, for Bredenburg; 1 shaper for La Riviere; 1 engine lathe for Regina.

1 pipe threading machine, 1 emery grinder, 1 mortiser, 1 rivetter, and punch shears, for Moose Jaw.

1 lathe, 1 shaper, and 1 emery grinder, for Outlook.

1 engine lathe, 1 iron shaper, 1 drill and 1 emery grinder, for Weyburn.

1 lathe, for Estevan; 1 tube saw, punching shears, and 1 screw clamp, for Sutherland.

1 lathe and 1 shaper, for Wynyard; 1 lathe and 1 bolt threader, for Hardisty.

1 emery wheel, for Strathcona; 1 boring mill, for Medicine Hat; 1 radial drill, for Lethbridge; 1 radial drill, for Cranbrook.

1 centring machine, 2 lathes, 1 turret lathe, bar iron shear, arm sander, double surfer, patternmaker's lathe, and 1 radial drill, for Vancouver.

1 engine lathe, 1 iron shaper, 30in. drill, 1 emery grinder, 1 bolt threader and punch shears, for North Bend.

1 lathe, 1 power hack saw, 1 emery grinder and 1 bolt threader, for Kamloops.

1 twist drill grinder, for Revelstoke; 1 lathe and 1 bolt threader, for Field; 1 turret lathe, for Nelson.

Lethbridge, Alta.—The Swift Canadian Co. will establish a packing plant here this spring.

Brandon, Man.—A shoe factory is planned for W. Percy Gillespie & Co. Work to start this spring.

Brantford, Ont.—The Brantford Showall Window Fitting Co. has commenced operations with 14 hands.

Palmerston, Ont.—The plant of the Canada Malting Co. was burned down on March 3. The loss will be around \$100,000.

Fort William, Ont.—The McKellar Bedding Co.'s plant is practically ready for the installing of the mechanical equipment.

Nelson, B.C.—The Jexite Powder Co., of Spokane, are looking for a site here on which to erect a plant. D. H. Farris, of Spokane, is president.

Montreal, Que.—The plant of C. H. Catelli Co., Ltd., manufacturers of alimentary paste, was destroyed by fire March 3. Damage, \$60,000.

New Westminster, B.C.—The elevator and mill of the Grain Growers' B. C. Agency is completed and awaiting the installation of the machinery.

Parry Sound, Ont.—Work on the plant of the Canadian Explosives, Ltd., at Ambo, is progressing rapidly. Frank Mackie, C.E., is the engineer on the job.

Amherstburg, Ont.—An addition to their factory is planned by the Amherstburg Canning Co. Manager, Mr. Burkhart. New machinery is required.

Montreal, Que.—The Canadian Bag Company have taken out a building permit to erect a factory in the vicinity of St. Patrick Street at a cost of \$190,000.

Sandwich, Ont.—Albert E. Ponsford, of St. Thomas, Ont., have secured the contract to build a \$38,000 factory here for the Dominion Cannery, Ltd. There will be engine and boiler rooms.

New Westminster, B.C.—The American Can Co., who recently purchased the Cliff Can Factory, took over the factory on March 1. They will increase its capacity and engage more men.

Owen Sound, Ont.—The Ben Allen Portland Cement Co. will build a new plant in the spring with 100-barrel capacity per day. Mr. McLeod is president. Tenders for constructional work to be called for shortly.

Toronto, Ont.—The W. E. Dillon Co., Ltd., manufacturers of sheet metal cornice, have purchased 50 feet of property, and will erect a four-storey

brick factory, a stable and garage. The lot has a depth of 175 feet.

Municipal

Sarnia, Ont.—The city has been authorized by the legislature to spend \$395,000 on waterworks, etc.

Toronto, Ont.—About \$4,000,000 worth of sewer construction work must be proceeded with at once, but contractors are scarce.

Dryden, Ont.—The city council are endeavoring to get better rates for light from the Dryden Timber and Power Co., and may erect a civic plant.

St. Thomas, Ont.—The city will erect a standpipe in the centre of the city to increase the water pressure for fire protection. It will be 125 ft. high, of steel and cement.

London, Ont.—The following sums are to be raised by debentures: \$72,000 for waterworks and \$110,000 for Hydro-Electric purposes. H. J. Glanvitz is general manager of the Board of Water Commissioners.

Kenora, Ont.—This town is strenuously objecting to the city of Winnipeg being given the right to develop water power at Shoal Lake. Shoal Lake lies between Ontario and Manitoba, and a deputation waited upon Hon. W. H. Hearst, Minister of Lands, Forests and Mines, recently, to urge that no concession be granted from the Provincial Government.

Vernon, B.C.—By-laws authorizing the town to spend \$5,000 on a roller, crusher and general road equipment; \$15,000 to purchase an additional unit for the electric lighting plant and to construct a power house; \$50,000 to purchase a second Diesel engine unit; \$35,000 for the erection of new pole lines, installation of transformers, meters, new connections and works necessary for reconstructing the electric lighting system, were submitted to the ratepayers on March 10.

Railways—Bridges

Toronto, Ont.—The council seems to favor steel for the construction of the Bloor St. Viaduct.

Victoria, B.C.—The B.C. Electric Railway Co. are contemplating extensions to their lines in this city.

Guelph, Ont.—Tenders will be called for soon by the city for the erection of a steel bridge on Heffernan Street.

St. John, N.B.—The C.P.R. will replace their cantilever bridge over the St. John River by a new structure. The St. John

Valley Railway Co. are urged to join with them in building it.

Toronto, Ont.—Gerrard St. bridge has been declared unsafe, and will be repaired, pending a new structure being built.

Sydney, N.S.—The Cape Breton Electric Railway Co., decided at its annual meeting last week to spend \$200,000 during the year on equipment. A new boat will be added to the ferry service.

Coquitlam, B.C.—A large caisson is now under construction by the Foundation Co. at the Pitt River. It is 73x38 feet, and is being built to a height of 20 feet before being placed in position at the draw span where it will enclose the pier at that point.

Toronto, Ont.—The Forest Hill Electric Railway Company, promoted by W. E. Grierson, T. J. Glover, R. R. Carr Harris, W. T. Rogers, and James Hales has been passed by the Legislature. It is a five-mile line, with two spurs of 2½ miles. \$50,000 must be spent on it within a year.

Victoria, B.C.—The British Columbia Government will spend \$200,000 this year on the construction of the substructure of a railway and traffic bridge over the Pitt River. When finished in 1915 it will have cost \$700,000. Hon. Thos. Taylor is Minister of Public Works.

Moncton, N.B.—The I.C.R. rolling stock is scarcely equal to the increase in traffic, but orders have been given for more than 2,000 cars of different classes as well as many locomotives. New cars are coming forward at the rate of eight a day. The working force in the Moncton shops has been increased by 200 men, and more would be taken on but for the difficulty of getting them.

Newcastle, N.B.—The contract for the substructure of the new steel bridge across the Miramichi River has been awarded to the Foundation Co., Ltd., of Montreal. The contract for the superstructure of the new bridge at Newcastle has not been awarded. The bridge when complete will probably cost about \$350,000.

Montreal, Que.—The Dominion Bridge Co. is building a bascule bridge on the Lachine canal banks, at St. Pierre aux Liens, Quebec, near the Canada Car & Foundry Works. The total length will be 300 ft., the moving part 200 ft., and the weight 600 tons. The bridge is being constructed so as to be operated by hand if the power fails. The contract was let by the Canadian government, and will be completed in time for navigation opening.

Water-Works

Galt, Ont.—Several pumps, to be driven by Hydro power and other machinery, has recently been installed at the waterworks.

London, Ont.—The water commissioners are negotiating for the purchase of the waterworks plant of the Chelsea Green Land Co.

Ridgetown, Ont.—A waterworks system to cost \$7,000 is planned by the town council. Engineer in charge, F. W. Farnecombe, London.

Toronto, Ont.—Works Commissioner Harris may shortly report on some springs at Lemonville as a source of water supply for North Toronto.

Calgary, Alta.—In connection with the operation of the reservoir, the commissioners recommend the purchase of a one and one-half million imperial gallon pump.

Montreal, Que.—The town of Beaconsfield has granted an exclusive twenty-five year contract for its water supply to the Vandrenil Springs Syndicate. J. L. Perron, K.C., Montreal, is the mayor.

Collingwood, Ont.—\$72,000 will be necessary to put the waterworks into shape. This will provide, a stand pipe with proper connections, a filtering plant and basin, fresh water basin, electric pumps, a new main up-town, besides other necessary equipment and changes.

Building Notes

St. Mary's Ont.—The C.N.R. will build a new passenger station this spring costing \$10,000.

Hamilton, Ont.—The Board of Trade is aiding in securing funds to erect a new hotel costing \$900,000.

Young, Sask.—A large hotel will be built by a company, of which S. H. Gaines is president. Work will start at once.

New Westminster, B.C.—Chas. F. Watson, architect, is preparing plans for a five-storey block for a Chinese syndicate, of which Mr. Law A. Soong is manager, at a cost of \$50,000.

Wood-Working

Cochrane, Ont.—A new mill is being erected at Jacksonborough which will employ 200 men.

Biggar, Sask.—E. A. Stroud is at the head of a firm which is building a planing mill and sash and door factory. The machinery has been purchased.

Montreal, Que.—A planing mill is to be built at a cost of \$5,000 by J. & W. Duncan Co., Ltd.

Roxton Falls, Que.—A furniture factory is contemplated for the Labriehere Co., Ltd. Water and steam power will be used.

Strathroy, Ont.—The Dymond-Colonial Furniture Co. will erect a large addition to their factory, four storeys high, for an upholstering department, a glueing room and shipping room.

Prince Albert, Sask.—The City Council have decided to submit to the rate-payers by-laws authorizing the sale of 60 acres of the municipality's lands to Felix Frank, manager of the Great West Iron, Wood & Chemical Works, Ltd., of that city. Mr. Frank wants 30 acres of the lands as site for a furniture factory and 30 acres for extending his company's present works by more than 100 per cent.

Tenders

Toronto, Ont.—Tenders were opened last week for a stone crushing plant, but the contract will not be let until a report is received from the works commissioner.

Moose Jaw, Sask.—Tenders for a fuel economiser with 7,000 sq. ft. heating surface, and an induced draft plant will be received up to March 26. J. L. Peters, electrical superintendent.

Toronto, Ont.—The time for receiving bulk tenders for all trades required in connection with the building of municipal abattoir and rendering building has been extended to March 18.

Ottawa, Ont.—The waterworks committee recommended that the tender of Thomas Lawson & Sons be accepted for hydrants, being the lowest. The matter was sent back to the committee by the council for further consideration.

Halifax, N.S.—Tenders addressed to the Mayor, for the construction of a Reinforced Concrete Reservoir and Gate House will be received at the office of the Committee on Works of the City of Halifax, N.S., until noon on Wednesday, April 2, 1913. J. J. Hopewell, Clerk of Works.

Fort William, Ont.—The contract for supplying the hollow tile to be used in the big plant of the Canadian Car and Foundry Company, has been secured by the Superior Brick and Tile Company. The contract will take the entire output of the plant for four months. The process of tile making will begin at the new plant about April 15 next.

Watrous, Sask.—Henry C. Allen, of Chicago, appeared before the council re-

cently, and submitted a verbal tender of \$73,844.30 for contract for proposed distributing system of waterworks and sewerage. This price included the supply of all material in connection with the work. He also submitted a separate verbal tender of \$51,344.30 if materials were all furnished. In both cases Mr. Allen offered to purchase \$75,000 worth of debentures at par if his tender was accepted.

Halifax, N.S.—Tenders will be received up to March 20 for the construction of the following bridges and culverts:—In East Hants, 128 structures; in West Hants, 48 structures. E. H. Armstrong, Commissioner of Public Works and Mines, Halifax.

Saskatoon, Sask.—Tenders will be received up to March 21st, for the following material:—(a) Lead Pipe and Galvanized Iron Pipe. 5,000 lin. ft. of 2-in. galvanized iron pipe. 2,000 lin. ft. of 1-in. galvanized iron pipe. 15,000 lbs. 3/4-in. lead pipe. 10,000 lbs. 1-in. lead pipe.

(b) Waterworks Brass Goods. 60—2-in. curb cocks iron to iron similar to Mueller D-6164. 600—3/4-in. curb cocks lead to lead, similar to Mueller D-5354. 500—3/4-in. main cocks, similar to Mueller D-5051. 300 1-in. main cocks, similar to Mueller D-5051. 100—3/4-in. lead to lead unions, similar to Mueller D-5001. 600—3/4-in. lead to iron unions, similar to Mueller D-5002. 160—1-in. lead to iron unions, similar to Mueller D-5002. 48—4-way branches, similar to Mueller D-5103 without goose necks and main cocks.

(c) 1,100 service boxes complete.

(d) 1,000—5/8-in. meters. 10—1 1/2-in. meters. 20—2-in. meters. 2—3-in. meters. F. E. Harrison, Mayor.

Contracts Awarded

Calgary Alta.—The contract for the 100,000 gallon water tower to be erected near the reservoir has been awarded to the Canadian Fairbanks Morse Co., Ltd., for \$9,600.

Vancouver, B.C.—Contracts were awarded last week by the B.C. Telephone Co. for the supply of steel work for the new exchange to be constructed on Seymour street, to Messrs. Coughlan & Sons.

Victoria, B.C.—The contract for castings has been awarded to the New Westminster Foundry Co., despite arguments against from the Victoria Foundry concerns. The price is \$31,473. The New Westminster Foundry Co. plant is in Sapperton.

The General Market Conditions and Tendencies

This section sets forth the views and observations of men qualified to judge the outlook and with whom we are in close touch through provincial correspondents.

St. John, N.B., March 11, 1913.—The firm of John White & Sons, this city, have secured a valuable strip of land on the Marsh Road, on which they will erect a fine new factory in order to cope with their increasing business. The lower portions of the new building will be of concrete, 40 by 100, and it is to be finished in most modern manner, as regards equipment, design, and construction. The firm now operate in Gilbert's Lane, but plan to remove to their new plant in which they will continue their manufacture of electric vacuum cleaners, about the middle of May, doubling the number of hands employed, and increasing their output.

The cornmeal mill of Maynes & Riley in City Road, St. John, was damaged by fire this week, and the loss is estimated at about \$3,000. The machinery was partially damaged. The loss was insured. George Murphy, of the firm of Kelley and Murphy, who for years have conducted a carriage factory in Main Street, has begun the erection of a new factory for the same purpose in Paradise Row. It will probably be completed about May 1.

Amherst, N.S.—The Board of Trade of Amherst, N.S., are at present considering plans whereby the number of industrial plants in that place will be greatly increased during the present year. It is now known under the significant title of "Busy Amherst," and the purpose of the industrial committee is to make it still busier. An effort is on foot, and is expected to be a success, for the establishment of a paper bag factory. Sir Robert Perks, who is interested in the New Brunswick Pulp and Paper Co., has given assurance that he will be willing to take \$5,000 stock in such an enterprise, and officials of the N.B. Pulp and Paper Co. have also intimated that they too would take stock in the concern. The industrial committee favors the establishment of the projected industry, and a committee composed of F. L. Milner, C. A. Lusby, Blair McLaughlin, W. A. Fillmore and G. K. McKean was appointed to push the matter forward. Two other industries are desirous of locating in Amherst, and their requests have been given over to the manufacturing committee of the Board of Trade. These are the Peerless Manufacturing Co., of Kentville, N.S., and the F. R. Wolfe Co., of Mahone, N.S.

Shipbuilding Plant and Drydock.

Members of the St. John County Council were in Fredericton last week

conferring on the matter of the proposal of W. Burton Stewart to establish a large shipbuilding plant and enlarge the drydock. G. F. Palmer explained the details of the plan and the members of the council gave their opinion that the matter of lengthening the drydock was for the government to consider. The members of the St. John County Council passed a resolution declining to share in the guarantee of \$65,000 a year for the shipbuilding plant, as it was felt that the people should have more information concerning the scheme, the capital interested, capacity of the plant, taxation, etc., before making any pledges.

St. John Harbor.

Some further extensions of the government works at St. John harbor are now contemplated, and it was said by Mayor Frink and Commissioner Schofield who returned from Ottawa this week, after interviewing some of the cabinet ministers, that arrangements had been made for entering into a part of the contract this year and it was expected that \$100,000 would be given as a start for the operations. The breakwater near the entrance to the harbor is to be extended quite a distance, to Partridge Island, thus closing the Western channel entrance to the harbor. In future all berths at West St. John are to be at least 850 feet long with steel sheds, and the new C.P.R. elevator is to be ready for business by next season. These and other bright assurances were brought home with the civic delegates, who besides interviewing the government, had a talk with the C.P.R. in Montreal as well.

Newcastle, N.B.

J. E. Ander and J. K. Pell have arranged to take over the woodworking factory of H. H. Lamont at Newcastle, N.B., and turn it into a plant for the manufacture of carriage bodies, gear, shafts, etc. The new company's request for tax exemption for twenty years except on the present valuation of the land was agreed to.

Montreal, March 10.—Business was decidedly good last week in the machinery market. Towards the end of the week the C. P. R. issued enquiries for new machine shop equipment for Western lines, amounting in value to between \$100,000 and \$125,000, and dealers are now busy figuring on this proposition. To-day the same railway placed orders for equipment for their

new steel car shop at Angus, most of the houses having received a share of the business. As a consequence, the general feeling continues to be highly optimistic, nearly all dealers reporting more business this winter than for the corresponding period in many years past.

Money.

General collections still drag, and the stringent monetary conditions are unimproved. However, very few failures are reported. The feature of the week was a most unjustifiable run on the Montreal City and District Bank. The run lasted for three days, during which time deposits to the amount of \$3,400,000 were withdrawn. The bank was able to satisfy all demands without calling in assistance from outside, and the run merely resulted in increasing the institution's already high reputation.

Pig Iron.

Business has remained good during the past week, though no especially large deals have been put through. English pig is up again, but Scotch shows signs of becoming a little easier in the near future. Enquiries are beginning to come in for deliveries after the opening of navigation.

Metals.

The metal market was very weak. After a slight rise, copper commenced to fall again in company with tin. Lead, too, fell steadily all week. There seems, however, to be a general feeling that the tone of the market will soon materially improve. Montreal metal merchants report that business is excellent for the time of year.

Toronto, Ont., March 11.—Without doubt the feature of the machinery market this week is the orders shortly to be placed by the C. P. R. for their shops between Montreal and Vancouver. Specifications have been sent out. The order for machine tools for the Canada Foundry Co., as detailed in last week's Canadian Machinery, has been let, or partly so, being distributed among several firms. From what was overheard in the market at the beginning of this week another large order for machine tools will soon be put on the market. The Canadian Fairbanks-Morse Co., Ltd., have opened up a warehouse at 280 King Street E., Hamilton, to take charge of their growing trade in the Ambitious City. D. T. White, who is well known in that locality, will be manager. The Russell Motor Co. are moving into their new building this week.

Steel and Iron.

That a radical change will take place soon in the steel market seems to be the firm conviction of steel men in this

locality. The change will affect pig iron and all brands of steel. For several days there has been a weakness on the American stock market, amounting to almost a panic. This has affected steel and rails most, and is attributed to the coming into power of the Democrats and the uncertainty existing as to what action President Wilson will take regarding the tariff. In the face of this, it is gratifying to learn that big Canadian concerns are making inquiries after pig iron among local representatives of the United States Steel Corporation. The latter concern seldom does business in Canada in pig iron. Their representative, when asked what this indicated, replied, "It means increased capacity." In further conversation, he intimated that he had been informed from New York that the wire mill would be the last of those to be built at Sandwich. Other despatches this week said that the wire mill would be built first. From another source it was learned that buying of pig iron would be heavier in a fortnight than now, due to the drop which is taking place in price across the border. There is somewhat of an unsettled feeling regarding the outlook generally.

Bars, Plates and Structural Steel.

Builders, although spring is practically here, are not buying structural steel, preferring to wait until prices go down. There is quite a demand, however, for steel for reinforcing concrete. After orders have been placed the mills should be extremely busy for the rest of the year.

Metals.

The price of copper has not experienced any change to speak of during the week, and is about the same as it was a week ago. The market is hardening, however, and there are signs of activity. Tin fell £3 in London on Monday, which is important, since tin has been satisfactory up to the present. Lead is about the same. The biggest metal business in Toronto was done in aluminium, which can be bought here at \$20. The market for old material is stagnant.

STEEL TRUST IN THE WEST.

THE United States Steel Corporation has invaded the Canadian West. This has been accomplished through a subsidiary company, registered in Canada under the name of the Imperial Iron & Steel Co., a concern capitalized at \$5,000,000. It has contracted to erect a plant at Prince Albert, Sask., by October 15, which will employ at least four hundred men, with a monthly pay-roll of \$36,000. A tract of thirty acres has been deeded to it by local men. All last summer, Pittsburg interests had three

prospecting parties in the north land. They brought back word that workable iron deposits of immense richness had been discovered, and it is in consequence of this that the enterprise has been launched. C. E. Gregory, K.C., returned from Chicago last week and after closing a contract with the corporation whereby they agree to fulfill the above requirements.

Plants for turning out bar iron, horse-shoes, etc., are to be erected at once. The company's engineer states that when the iron deposits have been tapped, wrought iron pipe works, employing 1,000 men, and open furnaces and rolling mills for steel rails and structural steel, employing 2,000 men, will be built. Because of a 35 per cent. duty on these articles coming from the United States, the company will be able to lay down rails for less than Pittsburg firms can do it, and cheaper than concerns in Sydney, N.S., on account of the long haul.

C.P.R. DOUBLE TRACKING PROGRAM.

THE C.P.R. has recently placed in operation further double trackage between Belle Plaine and Caron (33.3 miles), also between Walker and Chaplin (10.8), on the Moose Jaw and Swift Current sub-divisions. The programme for 1913 includes the laying of double track between Lemnay and Virden, between Whitewood and Grenfell; Indian Head and Regina, and from Gleichen to Sheppard (218 miles altogether), also completing the double track between Vancouver and Ruby Creek (81 miles), part of which is now in use.

Trade Gossip

Norman G. Neil, Industrial Commissioner for Port Arthur, has accepted a position in North Battleford, Sask. Mr. H. S. H. Goodier, secretary of the Board of Trade, has applied for his position.

Westerners Visit Eastern Plants.—The Western managers of the Canadian Fairbanks-Morse Co., Ltd., recently paid visits to the company's plants at Toronto, New York, and Montreal. The party included:—C. J. Brittain, Winnipeg, H. Crane, Saskatoon, and F. G. Robinson, Calgary.

F. L. Reed, manager of the Schacht Motor Co., Hamilton, will be retained as general manager for the Monarch Motor Co., who have secured the right to manufacture the Schacht cars in Canada. Each shareholder in the Schacht company will receive an equal number of shares in the new company.

Mr. F. S. O'Reilly, cashier of Mus-sens, Ltd., has resigned from the latter position to become accountant for the Canadian branch of Fraser & Chalmers, Limited, the well known manufacturers of mining and power machinery, of London and Erith, whose Canadian offices are at No. 4 Phillips Place, Montreal.

The Siemens Company of Canada, Ltd., recently obtained the order for two 1,900 H.P. peak load electric hoisting engines from the Dominion Coal Co., Nova Scotia. They had previously supplied the Coal Company with other large electric hoisting engines, all of which have given good satisfaction. In addition a total of 10,000 H.P. of electrical machinery has been furnished.

Taylor & Young, Ltd., mechanical engineers, Vancouver, B.C., are furnishing for the Nanaimo Electric Light Co., Nanaimo, B.C., a 450 b.h.p. compound high speed engine, manufactured by James Howden & Co., Glasgow, Scotland, which is direct connected to a 300 k.w., 2,200 volt alternator with direct connected exciter, manufactured by Bruce Peebles & Co., Edinburgh, Scotland. This order is of interest because of the fact that it marks the first installation of this make of engine in British Columbia.

The Hare Engineering Co., Ltd., 14 King St. East, Toronto, report the following orders recently received:—For Algoma Steel Corporation, Ltd., Sault Ste. Marie, Ont., a 575 H.P. condensing Terry steam turbine, direct connected to a single stage, 20in., Epping-Carpenter double suction volute pump having a capacity of 15,000,000 Imperial gallons per 24 hours. The turbine is direct connected to the pump, and will run at 1,200 r.p.m. A 225 H.P. Terry steam turbine for the O'Keefe Brewing Co., Toronto, to be operated on exhaust steam at 3 lbs. per gauge to 27in. vacuum. The turbine will run at 2,000 r.p.m. and be direct connected to a 150 K.W., D.C., Crocker-Wheeler generator. The vacuum is secured by a 1,000 ft. Wheeler condenser with Wheeler-Edwards' vertical air pump, and 25 H.P. Terry steam turbine, direct connected to a centrifugal circulating pump. The cooling tower will be placed on the roof of the building, 80 feet above the condenser. A large stoker fired forge furnace for the Nova Scotia Steel & Coal Co., of New Glasgow, N.S. This furnace is practically a duplicate of the one recently installed by The Canada Forge Co., Welland. The application of stokers to properly designed furnaces resulted in a saving of over 38 per cent. in fuel costs. An order for two No. 7,208 180 H.P. Fulton water-cooled mechanical stokers for the new plant of Rolph & Clark, Ltd., Toronto.

SELECTED MARKET QUOTATIONS

Being a record of prices current on raw and finished material entering into the manufacture of mechanical and general engineering products.

FIG IRON.

	Per Ton.	
Foundry No. 1 and 2, f.o.b., Midland	\$20 50	\$21 00
Gray Forge, Pittsburg	17 15	
Lake Superior, charcoal, Chicago	18 00	
	Mont'l. Tor'to.	
Canadian f'dry, No. .1	\$21 50	\$22 50
Canadian f'dry, No. 2	21 00	22 00
Middlesboro, No. 3....	23 50	23 50
Summerlee, No. 2	25 00	26 50
Carron, special	25 00
Carron, soft	25 00
Cleveland, No. 1	24 25	25 00
Clarence, No. 3	23 75	24 50
Jarrow	25 50	
Glengarnock	26 00	
Radnor, charcoal iron.	30 00	34 50
Ferro Nickel pig iron (Soo)	25 00	

BILLETS.

	Per Gross Ton.	
Bessemer billets, Pittsburgh ...	\$29 00	
Open hearth billets, Pittsburgh.	30 00	
Forging billets, Pittsburgh.....	36 00	
Wire rods, Pittsburgh	30 00	

FINISHED IRON AND STEEL.

Per pound to large buyers:

Cents.

Common bar iron, f.o.b., Toronto..	2.10
Steel bars, f.o.b., Toronto.....	2.20
Common bar iron, f.o.b., Montreal.	2.15
Steel bars, f.o.b., Montreal.....	2.25
Bessemer rails, heavy, at mill....	1.25
Iron bars, Pittsburgh	1.70
Steel bars, Pittsburgh, future	1.45
Tank plates, Pittsburgh, future...	1.50
Tank plates, New York, future....	1.61
Beams, Pittsburgh, future	1.50
Angles, Pittsburgh, future	1.50
Steel hoops, Pittsburgh	1.60

Toronto Warehouse f.o.b., Toronto.

Cents.

Steel bars	2.30
Small shapes	2.45
Warehouse import, freight and duty to pay:	Cents
Steel bars	1.95
Structural shapes	2.05
Plates	2.15

Freight, Pittsburgh to Toronto:

18 cents carload; 21 cents less carload.

BOILER PLATES.

	Mont'l. Tor'to.	
Plates, ¼ to ½-in., 100 lbs.	\$2.40	\$2.40
Heads, per 100 lbs.....	2.65	2.95
Tank plates, 3-16 in.	2.60	2.60
Tubes, per 100 ft., 1 inch	9.00	8.50
" " 1¼ in.	9.00	8.50
" " 1½ "	9.00	9.00
" " 1¾ "	9.00	9.00
" " 2 "	8.50	8.50
" " 2½ "	10.75	10.50
" " 3 "	11.95	11.50
" " 3¼ "	13.95	13.25
" " 3½ "	14.50	14.50
" " 4 "	18.00	18.00

BOLTS, NUTS AND SCREWS.

	Per cent.	
Stove bolts	80 & 7½	
Machine bolts, ¾ and less	65 & 5	
Machine bolts, 7-16.....	57½	
Blank bolts	57½	
Bolt ends	57½	
Machine screws, iron, brass	35 p c.	
Nuts, square, all sizes.....	4c per lb off	
Nuts, Hexagon, all sizes..	4¼ per lb off	
Flat and round head....	35 per cent.	
Fillister head	25 per cent.	
Iron rivets	60, 10, -0 off	
Wood screws, flathead, bright	85, 10, 7½ p c off	
Wood screws, flathead, brass	75, 10, 7½ p c off	
Wood screws, flathead bronze	70, 10, 7½ p c off	

WROUGHT IRON PIPE.

The following are Toronto jobbers' discounts on pipe. (Card weight) in effect from October 11th, 1912:

	Standard	Buttweld Black Gal.	Lapweld Black Gal.
¼ ¾ in.	63	48
½ in.	68	58
¾ to 1½	72½	62½
2 in.	72½	62½	69¼ 59½
2½ to 4 in. . .	72½	62½	71½ 61½
4½ to 6 in.	72 62
7, 8, 10 in.	66½ 54½
	X Strong P. E.		
¼, ¾, 1½ in. . .	64	54
¾ to 2 in.	68	58
2½ to 3 in. . .	68	58
3½ to 4 in.	65 55
4½ to 6 in.	63½ 56½
7 to 8 in.	56½ 46½
	XX Strong P. E.		
½ to 2 in.	43	33
2½ to 4 in.	43 33

WROUGHT IRON PIPE.

The following are Montreal jobbers' discounts on pipe. (Card weight) in effect from October 11th, 1912:

	Standard	Buttweld Black Gal.	Lapweld Black Gal.
¼ ¾ in.	64	49
½ in.	69	59
¾ to 1½	73½	63½
2 in.	73½	63½
2½ to 4 in. . .	73½	63½	72½ 62½
4½ to 6 in.	74 64
7, 8, 10 in.	70½ 58½
	X Strong P. E.		
¼, ¾	64	49
½ in.	65	55
¾ to 2 in. . .	69	59
2½ to 3 in. . .	69	59
3½ to 4 in.	66 56
4½ to 6 in.	65½ 58½
7 to 8 in.	60½ 50½
	XX Strong P. E.		
½ to 2 in. . .	44	34
2½ to 4 in.	44 34

IRON PIPE FITTINGS.

Canadian malleable, 40 per cent.; cast iron, 65; standard bushings, 70; headers, 60; flanged unions, 65; malleable bushings, 65; nipples, 75; malleable, lipped unions, 65.

COKE AND COAL.

Solvay Furnace Coke	\$5.25
Solvay Foundry Coke	6.50
Connellsville Furnace Coke	5.75
Connellsville Foundry Coke	6.25
Yough. Steam Lump Coal	3.75
Penn. Steam Lump Coal	3.63
Best Slack	2.95
All net ton f.o.b. Toronto.	

OLD MATERIAL.

	Tor'to.	Mont'l.
Copper, light	\$11 00	\$11 00
Copper, crucible	14 00	13 50
Copper, uncre'bled, heavy	12 00	12 00
Copper wire, uncre'bled..	12 00	12 00
No. 1 machine compos'n..	11 00	11 00
No. 1 comp's'n turnings..	10 00	10 00
New brass clippings	9 00	9 00
No 1 brass turnings	7 50	7 50
Heavy lead	3 25	3 00
Tea lead	2 50	3 00
Scrap zinc	3 50	3 75
Dealers' purchasing prices.		



32 H.P. ALBION

Some Reasons Why You Should Buy

ALBION TRUCKS

1. *The Albion Motor Car Company of Glasgow, Scotland*, on account of the reliability and economy of their Trucks, have become the largest manufacturers of Motor Trucks in the British Empire.
2. *Twelve Years' Experience of Truck Construction* in all parts of the world (sixty trucks in Canada) back of every "Albion."
3. *Economy in First Cost*. 12½ per cent., or about five hundred dollars, on a 3½ ton machine saved by British preference in duty and the machines manufactured where the highest grade of skilled labor and material can be obtained at low rates.
4. Tires of nearly double the size of those supplied on standard American machines, with the consequent large savings in operating cost, as tire maintenance is the chief cost of truck operation.
5. *Cast Steel Wheels*, which last forever.
6. *Ease of Control*. There is only one lever and two pedals to control the machine. The gears are always in mesh and the engine is equipped with a powerful governor controlled from the driver's seat, which enables the truck to be set to run at any speed up to the maximum, thus making the driving of the machine as simple as possible.
7. *Albion Service*. We will have *Demonstration Trucks, Complete Stock of Spare Parts, and Expert Mechanics* from the Albion Works in Montreal and Toronto.
8. Recent order from the *Canadian Pacific Railway*, after report on the design and construction by their engineers.
9. The "Albion" represents the *Maximum Value in First Cost* and the *Minimum Cost of Up-keep*. Let us prove this to you by examining the truck carefully and noting the many features that lead to reliability and long life in its construction. You will find Albion Trucks at all the Motor Shows completely opened up for inspection, as we believe there is no detail that will not bear the closest scrutiny.
10. Ask any chauffeur or anybody familiar with Motor Cars from Great Britain, and you will find the "Albion" on account of its reliability is the leading truck of the Old World. Capacities, one to five tons.

Albion Motor Car Co. of Canada

Montreal and Toronto

SMOOTH STEEL WIRE.

No. 6-9 gauge, \$2.35 base; No. 10 gauge, 6c extra; No. 11 gauge, 12 extra; No. 12 gauge, 20c extra; No. 13 gauge, 30c extra; No. 14 gauge, 40c extra; No. 15 gauge, 55c extra; No. 16 gauge, 70c extra. Add 60c for coppering and \$2 for tinning.

Extra net per 100 lb.—Spring wire; bright soft drawn, 15c; charcoal (extra quality), \$1.25.

METALS.

Prices in cents per pound:

	Mont'l.	Tor'to.
Lake copper	16.00	15.75
Electrolytic copper	16.00	15.75
Spelter	6.00	6.00
Lead	4.15	4.50
Tin	50.50	49.00
Antimony	9.75	10.00
Aluminium	22.00	23.00

SHEETS.

	Mont'l.	Tor'to.
Sheets, black, No. 28....	\$2 85	\$3 00
Canada plates, ordinary, 52 sheets	2 80	3 00
Canada plates, all bright.	3 70	4 15
Apollo brand, 10¾ oz. (American)	4 30	4 20
Queen's Head, 28 B.W.G.	4 40
Fleur-de-Lis, 28 B.W.G..	4 20
Gorbal's Best Best, No. 28	4 45
Viking Metal, No. 28....	4 40

NAILS AND SPIKES.

Standard steel wire nails, base	\$2 40
Cut nails	\$2 60	2 65
Miscellaneous wire nails..	75 per cent.	
Pressed spikes, 5/8 diam., 100 lbs.	2 85

FINE STEEL WIRE.

Discount 25 per cent. List of extras.
In 100-lb. lots: No. 17, \$5; No. 18, \$5.50; No. 19, \$6; No. 20, \$6.65; No. 21, \$7; No. 22, \$7.30; No. 23, \$7.65; No. 24,

\$8; No. 25, \$9; No. 26, \$9.50; No. 27, \$10; No. 28, \$11; No. 29, \$12; No. 30, \$13; No. 31, \$14; No. 32, \$15; No. 33, \$16; No. 34, \$17. Extras net. Tinned wire, Nos. 17-25, \$2; Nos. 26-31, \$4; Nos. 30-34, \$6. Coppered, 75c; oiling, 10c.

MISCELLANEOUS.

	Cents
Putty, 100 lb drums	\$2.70
Red dry lead, 560 lb. casks, per cwt.	6.25
Glue, French medal, per lb	0.10
Glue, 100 flake	0.11
White lead, ground in oil, No. 1 pure, 100 lbs.	8.40
Tarred slaters' paper, per roll...	0.95
Motor gasoline, single bbls., gal..	24½
Benzine, per gal.	23½
Pure turpentine	64
Linseed oil, raw	58
Linseed oil, boiled	61
Plaster of Paris, per bbl.	2.10
Plumbers' Oakum, per 100 lbs..	4.25
Pure Manila rope	17

CANADIAN PLANT NATIONAL CASH REGISTER CO.

THE National Cash Register Co., Dayton, O., will build a large plant at Toronto, Ont., on a site of eight acres, which will be served by the Canadian Pacific and Canadian Northern Railways. The plant will consist of three buildings, including a foundry, 60 x 120 feet; machine shop, 300 x 60 feet, two storeys high, and the main building, 310 x 60 feet, three storeys high. The latter structure will contain the offices, assembling and stock departments. Eventually, a wood-working plant is to be erected. All of the building will be of uniform construction, the frame work being of steel, the foundations concrete and the floors laid with laminated wood.

The foundry will be equipped with two batteries of coke furnaces, 10 furnaces to a battery, and to recover the metal from skimmings and foundry ashes a washer will be installed. A large number of molding machines will also be purchased. The building will be divided into spans of 25 feet, 10 feet and 25 feet, the 10-ft. span serving as an aisle, providing a working area 25 feet wide on either side. The buildings are arranged so that the stock can be routed in a direct line to the point of outlet.

The large window area of these buildings will be a noteworthy feature, as the walls will contain approximately 85 per cent. of window space. All of the structures will be so built that they can be added to without inconvenience.

Partitions will be portable and built of steel and glass. The basement of the main building will contain wash rooms, lockers, shower baths, lunch and recreation rooms and the officers' club. The services of a landscape gardener will be employed to lay out the grounds, which will include an athletic field for the company's employes. Mr. H. Daly is superintendent of the Canadian factory.

LAKE SUPERIOR CO.'S INCREASES.

IN January The Lake Superior Corporation and its subsidiaries showed very large increases in the net operating results.

The coking plant, with its capacity of 1,000 tons a day, and the rail mill, which is rolling 1,200 tons a day, are now in perfect working order. These are the latest additions to the equipment of a concern in whose various plants large sums of money have been expended in recent years. More blast furnace capacity is now required, although 1,000 tons of pig iron are already being turned out each day.

While the improvements undertaken to date were practically completed last year, during the inevitable tuning up process, the plants have shown good increases each month, and they are all now gradually running up to full capacity. In the steel plant during January, there were large increases in production in almost every department, and considerable benefit was also derived as the result of improved efficiency. The

production of steel rails alone for that month was 28,812, or 3,711 tons greater than that for any single month in the history of the Corporation.

This is all the more gratifying in view of the fact that work in the winter months is always carried on under far more unfavorable conditions than during the remainder of the year.

Montreal, Que.—Penman's, Ltd., will enlarge their knitting mill at Ste. Hyacinthe. Headquarters are at Paris, Ont.

Dundas, Ont.—The Swift Packing Co., of Chicago, have secured options on two 100-acre farms, and will, it is thought, erect a plant here.

SITUATION WANTED

WANTED—POSITION AS TRAVELLER OR accountant by young man with seven years' experience in machinery and iron trades. Both languages. Furnish bond or references. V. D. Poultn, Box 428, St. Johns, Quebec.

SIDE LINES WANTED

MANUFACTURING CONCERN IN ONTARIO having splendidly equipped factory wants good live article to manufacture on contract or royalty. Box 123, Canadian Machinery & Manufacturing News. (10)

PATTERNS
WOOD AND METAL
Allow us to estimate. Satisfactory work guaranteed.
TAYLOR PATTERN WORKS WALKERVILLE, ONT.

Developments in Machine Shop Practice During a Decade*

In this report, the principal improvements in machine shop practice developed approximately during the last ten years are reviewed. Taken in conjunction with the article entitled "A New Era in Machine Tool Design," which appeared in our issue of March 6, there is brought within the grasp of our readers a wealth of valuable data regarding past achievement and future ideals, from which they may secure helpful instruction, and at the same time be kept informed of the progress being recorded, relative to their craft and calling.

THE reason for presenting an extended review now is that the subcommittee on machine shop practice should record the advances made each year, but in the present case, the committee having been only recently organized, there exists in the society's proceedings no consecutive account of progress. To carry the record back to a logical date, that of the report made by Fred J. Miller to the Bureau of the Census, in 1905, is mentioned, but, of course, the actual date is somewhat indefinite.

Introductory.

The review is incomplete because of the limitation of time to prepare it, and because of a natural diversity of opinion as to the limitations of what should properly be considered machine shop practice. If this review has included matters generally regarded outside of the limitations, it may be considered that the larger field was included because of practical difficulties in drawing a well-defined line between machine shop practice as such and machine design, administration, heat treatment of steel and other factors affecting production. To ignore them is impossible. The operation of metal-working tools and their productive capacity are as much matters of machine design, arrangement and management as of individual skill. In fact, productive capacity in the past depended very largely on the skill and initiative of the workman, but now the rate of production in many branches of manufacture is almost entirely governed by the construction of machines, so that the designer, when viewed in this light, is closely allied with shop practice.

"The transference of skill" by the machine designer from the operators to the machines has embodied in the latter much of the accumulated experience of many mechanics working on simpler and more primitive tools; therefore, it may be asserted that much of the improvement in machine shop practice has appeared in the improvement of machine tools themselves in one way or another.

Variety of Machine Shop Practice.

When it is considered that machine shop practice embraces a very wide

variety of work, ranging from the smallest to the largest manufactured products, and all kinds of repair work, the difficulty of classifying and differentiating it can be appreciated. Locomotive repair work, for example, is in a class by itself, in which peculiar methods have been developed, differing radically from those followed in doing similar work in other lines. The slotter, for example, is a machine tool in high favor in railroad shops and, outside of shipyards, has been little used elsewhere. It is, however, slowly coming into use in manufacturing works. The milling machine until a few years ago had not gained a footing in railroad repair shops, largely because it was and still is not as well adapted to handle the general run of plane finishing required in these shops as the planer and shaper. The latter are adaptable machines peculiarly suited to non-repetitive operations, while the milling machine excels in manufacturing.

Increased Weight of Machines.

One of the noticeable changes in machine shop equipment during the past ten years is the increased weight and power of machine tools, which was made necessary through the general application of high-speed steel cutting tools. While the increased capacity of machines which followed in the wake of the application of high-speed steel was directly instrumental in bringing about such increases in the weight of machines, the result has been beneficial, not only in increased production, but in accuracy of product, because of greater rigidity and consequent better preservation of alignment.

Foundations.

Progress has also been made in the methods of erecting machinery. With large size machines, the foundation plays a most important part in the accuracy of the work produced. For instance, the provision of a massive, well-built foundation for large planers is imperative. When not provided, the weight of the machine and work must inevitably cause settling and springing out of shape. Every mechanic knows that such a disturbance of the foundation affects the alignment, which means that the work produced on the planer will be inaccurate; the use of leveling

plates under the feet of planers to provide uniform support and means for correcting errors of alignment has become general; the elimination of defective action due to want of support, and the increased mass and rigidity have in the case of planers resulted in the production of plane surfaces closely approaching theoretical planes when the work itself affords the necessary rigidity and uniformity of section. Hence, hand scraping to perfect alignment is not as necessary as it was a few years ago, and it may be said that on some classes of work scraping is now largely more of an ornamental than a corrective process. On high grade machines, however, scraping or grinding probably will continue to be necessary to correct inaccuracies of surface and alignment.

Electric Motor Drive.

The subject of electric motor drives was given much prominence in discussions of machine shop practice a few years ago, the bias being generally in favor of individual motor drive. While subsequent experience has shown that the direct-connected electric motor has certain limitations and disadvantages for some classes of work, it has also shown that the same results and efficiency cannot be obtained with the group system of driving modern designs of machine tools. The investment in motors is less with the group system, but the flexibility of the independent drive is lost. When a machine driven by an independent motor is properly equipped for easy handling, increase of production over that of the same machine in a group system is practically insured. One machine tool builder has found it a good rule to apply independent motors wherever the power requirement is 5 h.p. or more. Hardened steel gears in the driving train reduce gear troubles to a minimum. When the character of work is constantly changing and new groupings of machines are required from time to time, the individual drive is of great advantage. The machines can then be placed "like men on a checker board."

Improvements have been made in the characteristics of variable speed and reversible motors. Automatic controllers have been introduced which make the stopping and starting of machines simply the matter of pushing a button.

*Report of Sub-Committee on Machine Shop Practice, presented at the annual meeting of the American Society of Mechanical Engineers.

These devices protect the motors, save time and protect the machines from shocks.

Automatic Machines.

Progress has been made in the development of automatic and semi-automatic machines for the production of duplicate parts from bar stock, iron and brass castings. Many special fixtures have been designed for automatic screw machines which have widened their scope to include a great variety of small parts on which a number of operations must be performed before cutting off from the bar, such as small spiral gears, capstan screws, etc. The cost of production is so greatly reduced that these machines are generally applied where the quantity of work to be produced warrants the cost of installation and tool maintenance. The scope of other types of automatic machine tools is wide and constant increasing. Certain examples will be mentioned later. Many pages could be devoted to the improvements in these machines alone without exhausting the topic; but attention is called here to the simplification of equipment required for the manufacture of highly developed specialties because of the possibility of buying the bulk of the parts from screw machine product specialists. A manufacturer of a specialty can, if he chooses, organize on an assembling basis, confining his actual manufacture to the making of a few principal parts. This development is having a marked influence on our export trade.

Training Mechanics.

Modern methods of manufacturing are responsible for limiting the employment of men to specific operations only, and pursuit of the plan is making it hard to secure all-round machinists. Young men come into the factory and soon acquire the necessary skill to become proficient drill press operators or milling machine operators. They are able to earn fairly good wages in a shorter space of time than if they served the necessary term of apprenticeship to become competent all-round machinists. The endeavor has been made in the larger manufacturing cities to offset the narrowing effect of specialized training by the introduction of training schools in which young mechanics are given instruction in the theoretical side of their work. The results obtained by this training are beneficial. Men are acquiring both theoretical and practical knowledge, so that to a limited extent at least, they are obtaining the benefits of a technical education coupled with practical training.

Scientific Management.

The noteworthy improvements in shop practice is the application of principles of scientific man-

agement. While the details and elements that make up the complete system advocated by Mr. Taylor are not widely used in full, undoubtedly the fundamental principles are coming to be more thoroughly understood and are being quite generally applied. Some of the more specific improvements referred to in the following may not be strictly modern, but doubtless most of them can be so classified because they are now common, whereas ten years ago they were found in comparatively few shops.

Standardization of Tool Grinding.

The turning and planing tools in many shops are now ground to standard shapes in the tool-room on special grinding machines. The method not only saves the time of the machine tool operator, but insures the grinding of all tools to the correct form, and it also saves what is of great value—the loss of the productive time of the machine tool. The stock of tools required for a shop is also much smaller.

Checking System for Small Tools

Most shops at the present time keep all small tools in the store room, except those in actual use. In this way, the tools are kept in good condition and a much smaller stock is required. Not many years ago it was quite common for each workman to have his own stock of tools. Consequently there were good tools and poor tools just in proportion as there are good workmen and bad workmen. For instance, a lathe operator had his own stock of mandrels which were made to suit each particular job, and when necessary one man borrowed from another. The result was that the workman wasted a great deal of time wandering around looking for mandrels and other auxiliary equipment. It may seem somewhat out of place to refer to this well-known method of handling small tools by a checking system in a paper on modern improvements, because it is an old feature of many shops. This system was not generally employed ten years ago in many of the small and medium sized shops.

In some shops in which scientific management has been applied, and where the work in connection with each operation is planned in advance, it is the practice to make up at the time the work is planned, a list of the tools that will be required for the performance of each operation, this list being sent to the tool room in advance of the time that the tools will be required, and the tools delivered to the workman by a tool carrier, thus saving the time of the workman as well as that of his machine.

Speeds and Feeds.

The important question of speed and feed in connection with machining opera-

tions has, during recent years, been carefully studied by many superintendents and foremen who formerly relied entirely on the judgment of the workmen, which was sometimes good and sometimes bad. Speeds and feeds are fixed in the planning department and are based on the power of the machine and character of the metal.

More thought is now given to the selection of machine tools for various classes of work. A few years ago, many shop foremen used a certain type of machine for a given class of work, because that type had always been used for that purpose. It seems that there is much less conservatism to-day, and precedent does not count for as much as it did a few years ago. The tendency is to design the machine for the work instead of adapting the work to the machine equipment.

Inspection of Finished Parts.

Machine parts are now carefully inspected in many shops by an independent inspection department, whereas, formerly, the only check on the accuracy of machined work was in the erecting department—if everything could be assembled, the work was considered satisfactory. The more exacting requirements of recent years, however, made necessary the general adoption of a rigorous system of inspection. Thorough inspection and testing are necessary features of interchangeable manufacturing methods; tools and systems have become highly specialized. In the manufacture of firearms and other high grade products from fifty to one hundred separate tests or gaugings on a single part are not uncommon.

In some shops doing work of a miscellaneous character, it is the practice to have an inspector go to the machine at the time a job is started to make sure that the workman understands all of the requirements with reference to the quality required in the work that he is to do, instructing the workman as to the degree of accuracy required, the kind of finish, etc., and seeing that he does not make a mistake in reading his drawing, setting his measuring tools, etc. The inspector inspects the work done in the operation in question upon the first piece where there are several pieces to be done, thus avoiding the danger of an error on the first piece being repeated on all subsequent pieces. An inspection is also made upon the completion of each operation of the work done on all pieces in the lot for the purpose of detecting any error that may have been made, so that steps may be taken for its correction without delay.

Cooling Lubricants.

Another improvement in shop practice worthy of mention is the more generous

use of cooling mediums on cutting tools, and the provision of distribution systems for both the tools and the bearings supplied from a central reservoir.

Use of Multiple Tools.

The increasing use of tools in multiple is a feature that is noticeable in connection with the modern machine shop. Milling machines are now quite extensively used having several spindles, making possible the finishing of three or even five sides of a casting at one setting, many holes are drilled simultaneously, and in practically the same time formerly required for drilling one hole, and so on.

Better Facilities for Setting Up Work.

The up-to-date foreman or superintendent has come to realize that the efficiency of his shop depends largely on the amount of attention given to the little things. The furnishing of proper clamps and bolts to machine tool operators is a case in point. Poor bolts and warped clamps around a machine often double the time required for setting up work. At the present, most shops are equipped with proper clamping facilities and, in many cases, clamps of the right shape and bolts of the right length are furnished for each particular job, along with the other tools, such as cutters, reamers, etc. These tools are being kept in the toolroom instead of at the machines as formerly; thus the responsibility for their maintenance in first class condition is concentrated in the toolroom, where they are inspected upon being returned after their use in connection with each job, and any necessary repairs promptly made. The difficulty of holding a large number of men responsible for the upkeep of these tools is thus avoided, and each workman has a larger variety of bolts, clamps, blocks, etc., to draw upon than he can possibly have where each man has his own supply.

Location of Tools and Lighting.

More attention is given to the relative location of tools in the shop, in order that all machining operations can be performed with no unnecessary handling of the work, the aim being to finish parts by advancing them from one tool to another in a direct line without any see-sawing or useless movements. Shops are constructed so that the light will be properly diffused, which makes it easier for the machinist to do accurate work and reduces the amount of spoiled work. The physical comfort of the workmen is also receiving more and more attention.

Drilling Machines.

High-speed steel has been substituted for carbon steel in the manufacture of twist and flat twist drills with marked

improvement in capacity. The speed of drilling has been increased two or three times if not more. The drilling machine, the most common machine tool, has been redesigned to meet the new requirements and so rapid are some of the most highly developed machines on the market, that holes can be drilled in boiler plate quicker than they can be punched.

The claim is made by engineers who have carefully investigated the matter, that 80 per cent. of all the holes drilled in general manufacturing are $\frac{3}{4}$ inch in diameter or less. The fact is pointed out that general purpose drills with a capacity of from $\frac{1}{8}$ inch to 3 inches are not efficient except within a narrow zone somewhat between the two extremes cited, desirable as they are when on deep drilling or on large diameters requiring a geared drive; hence the general recognition of the importance of comparatively small capacity drilling machines in the equipment of efficient plants.

Multiple drilling machines with from two to fifty or more drills in operation simultaneously, have been developed. Inverted drilling machines with which the capacity of drills is increased largely because of the rapid clearing of chips from the holes are being used with satisfaction, also multiple drilling machines working in several planes simultaneously, making feasible the drilling and reaming of all holes in machine parts such as automobile cylinders at one operation. Another development is the rotary table semi-automatic drilling machines which relieve the operator of lifting and lowering the spindle and engaging and disengaging the feed.

A minor improvement of machine shop equipment which has increased the productive capacity of single-spindle drilling machines is the so-called roller grip drill chuck which enables the operator to insert and remove drills, reamers, counterbores and other tools without stopping the spindle. These chucks are useful for certain kinds of work requiring drilling, reaming and counter-boring operations. In the same connection, mention should be made of tapping attachments, stud setting chucks drill speeders, and similar attachments which improve the working range of drilling machines.

The need of the old style reversing countershaft has been eliminated from drilling machines by automatically reversing tapping attachments, automatically opening stud-setters; while many screw-threading operations are now performed on drill-presses with special forms of automatically opening dies, at a great saving over the former method of chucking the work on a turret lathe.

Lathes.

The improvements in lathes have been chiefly in matters of strength, power, and details of construction. Spindles are made larger and are supported in longer bearings, improvements have been made in carriages, tailstocks, toolrests, apron mechanism, stops, ways, spindle noses, gear boxes, change gear and feed mechanisms, etc. Three stop cone pulley and double back gear headstocks have been widely adopted for high power rapid reduction lathes, this construction providing a wide range of speeds with simple and efficient mechanism. Quick change gear mechanisms which enable the selection of gear combinations for screw thread cutting to be made practically instantaneously have been generally provided by lathe builders. The demand for simple lathes—that is, lathes without change gears, lead screws and other standard features of complete engine lathes, has not been insistent; hence we still have the anomaly of thousands of lathes in manufacturing plants that are never used for thread cutting but which have the change gears, lead screws, and other parts required for screw cutting.

The reason ascribed by one prominent lathe builder is that the application of the simpler mechanism required for feeding only, makes comparatively little difference in the cost of a lathe. The elimination of the change gears reduces the number of available feeds; but the chief objection is the loss of inventory value when regarded as second-hand tools.

Wheel Lathes.

A remarkable increase of efficiency has been made in locomotive driving wheel and ear wheel lathes. Ten years ago, turning the tires of two pairs of drivers was a good day's work, and most railway shops did much less. High-speed steel has worked one of its greatest triumphs in this field. Tire turning lathes have been developed to equal the capacity of the best steels and the productive capacity has been increased to 8 or 10 pairs of drivers a day. The increase of capacity of steel tire ear wheel lathes is nearly as great, having been raised from 5 or 6 pairs to 18 or 20 pairs a day.

Planer Drives.

A weak feature of planers and a serious limitation to the power of large planers, is the common shifting belt reversing mechanism. On small planers even the shifting belts are objectionable because of slipping and the characteristic squeaking noises, but on large planers their fault is of more serious nature. Wide belts necessary to transmit the required power at practical speeds cannot be shifted from the tight to the loose pulleys and vice versa quick-

ly. Clutches of various designs are used with varying degrees of success. The reversing electric motor direct connected to the planer drive has been developed to the point that makes its success assured. Probably this change of drive is the most marked improvement in planers made in recent years. Many details have been improved, and the greater strength and rigidity of the modern planer, coupled with excellent workmanship, insures accurate work.

Milling Machines.

A change in machines for producing plane surfaces has been going on gradually but surely. Planers, shapers, and slotting machines are being displaced by various types of milling machines in manufacturing plants. As plants change from a building to a manufacturing basis, the superiority of the milling machine as a manufacturing machine gives it the preference. The development of coarse-pitch teeth milling cutters and of face milling machines are two of the marked improvements.

Single pulley drive with which the maximum power capacity of a given width belt can be transmitted to the machine, irrespective of the work spindle speed, and geared speed boxes giving a wide range of positive speeds are other important changes in design. The vertical spindle milling machine has been developed to a high plane of efficiency, especially for small work. Rotary table machines, with quick action clamping devices revolving continually while the operator places the work in position and removes the finished parts, are coming into extensive use.

Characteristics of modern milling machines also common to other modern machine tools are convenience and ease of operation, starting and stopping levers being placed where the operator can grasp them without leaving his normal position; speed and feed levers so placed as to permit the operator to control the rate of cutting while watching the work; power traverse of slides on heavy machines, etc.

Boring Mills and Boring Machines.

The boring mill has taken a commanding place as a machine tool for both light and heavy work. When equipped with turret heads and a proper complement of tools its productive capacity has been made second to none. Convenience of operation, economy of floor space, compactness of design, adaptability to use of lubricants on cutting tools, are some of the advantages of this machine which have been emphasized in the new designs brought out in recent years. The builders have studied to find the best order of operations and equip with chucks and tools that pro-

duce an output far in advance of that possible 10 years ago.

The horizontal boring machine of the bed and carriage type which has been developed practically within the past 10 years, partakes of the characteristics of the lathe milling machine and boring mill, and in the improved designs is superior to any one, for certain classes of work. One of many uses to which it is devoted is that of boring jigs and fixtures for interchangeable production. Not only is it useful for jig making but it is peculiarly well suited for manufacturing machine parts interchangeably without the use of jigs. This important fact enables machine tools and similar high grade machines to be economically produced on the interchangeable plan during the very active period of developing the design.

Magnetic Chucks.

Magnetism for holding steel and iron parts for grinding, planing and turning operations has been made useful, especially for thin parts that are easily sprung out of shape by ordinary clamping means. Magnetic grinding, planing and lathe chucks have come into common use in plants having up-to-date equipment.

Grinding Machines.

The surface grinder, especially the vertical spindle type, has made great strides during the last few years. The improvements in cylindrical grinding methods are also worthy of mention, especially the use of the heavy-duty grinder for removing stock formerly removed by a second or finishing cut in a lathe. Grinding stock from the rough as in the finishing of drop forged crankshafts is also a good example of modern practice. The stage has been reached in cylindrical grinding practice which places the cylindrical grinding machine on a co-ordinate basis with the lathe as a tool for finishing cylindrical work.

A feature of cylindrical grinding machines which has greatly increased productive capacity in multiple diameter work is the stop bar or semi-automatic measuring attachment which enables shouldered shafts, etc., to be duplicated without measurement. Machines for internal grinding of non-revolving work with planetary spindles provide for the economical and accurate sizing of engine cylinders and other parts difficult to rotate. Vertical grinding machines and rotary work-tables utilizing magnetic chucks or other rapid action clamping means for quick securing and releasing the parts to be ground have come into extensive use for high-grade interchangeable manufacturing. The development of the disc grinder from a mere smoothing machine to a powerful machine tool of great capacity for finish-

ing plane and curved castings from the rough is one of the most interesting phases of modern practice.

Screw Thread Milling.

One of the notable improvements in the cutting of lead screws, feed screws and other machine screws, especially those required to be exact in pitch and lead is the substitution of special milling machines in place of the common engine or screw cutting lathe. Milling screws is by no means a new idea but the commercial development of special screw thread milling machines has taken place within the past few years. The machines not only increase accuracy, but materially reduce the labor cost, one man being able to tend from three to six machines.

Jigs and Fixtures.

The development of jigs and fixtures for interchangeable manufacturing has been remarkable. The expansion of automobile manufacture has been enormous and most of the leading concerns employ jigs and fixtures exclusively, thus insuring interchangeability, low production cost and systematic production. Many improvements have been made in the way of clamping devices, standardization of bushings, handles, levers, frames, etc., too numerous to mention specifically. Toolmaking has been developed on manufacturing lines, and, in fact, several concerns specialize on the making of tools, jigs, fixtures, punches and dies, and produce them exclusively for manufacturing plants.

Gear Making.

The demands of automobile users for quiet running gears have imposed on gear makers conditions very difficult to meet. The limits of error in shape and spacing of teeth have been greatly reduced and coupled with the necessity of making highly accurate gears, often has been that of producing them from tough alloy steels, heat treated after cutting the teeth. Hardened and case-hardened gears are also demanded with minimum limits of error. The planing process has been generally substituted for milling in the manufacture of high grade bevel gears, thus producing theoretically correct tooth shapes instead of the approximation possible only by the formed milling cutter process.

Gear hobbing machines have been widely adopted for cutting spur and spiral gears, because of the greatly increased capacity and simplicity of operation. Machines and methods for cutting the teeth of integral herringbone gears cheaply, have been developed, thus making this form of gear available for machinery generally in which it has not been commonly used because of high cost of the two-part type. The demand

of automobile users for noiseless gears has led to grinding the teeth of gears after hardening to correct form, and form grinding generally, including splined shafts for automobile change gear shafts and similar parts. Progress has been effected in the making of gears by the hot rolling process, producing them tens with a minimum waste of material and of exceptional physical characteristics. Progress has also been made in the use of rotary cutters in gear manufacture. The substitution of high-speed steel for carbon steel has, of course, made higher cutting speeds possible, and improved designs of gear cutting machines have in turn made the cutters work more efficiently because of greater power and rigidity of support. Exhausts to draw away the chips and cool the cutters have made a notable improvement in efficiency, making greater speed and smoother cutting possible.

Small Tools.

The design and manufacture of small tools have been improved principally in details. There has been a tendency to decrease the number of teeth of milling cutters, making possible heavier roughing cuts with proportionately less expenditure of power. While the extreme coarse spacing of the teeth advocated by some leading engineers has not been generally adopted, all manufacturers of milling cutters have, to some extent, modified the tooth spacing of their cutters. Several special milling cutters with inserted teeth have also been proposed and, to some extent, adopted. The tendency has been towards the design of easily adjusted removable blade type reamers, and several satisfactory designs have been brought out. The flat twisted high-speed steel drill has been commercially developed, and several modifications of it have been placed on the market. The main progress in tap making, perhaps, has been towards a more satisfactory shape of the flute, and several tap makers have made experiments in this direction.

In general there has been an attempt to design inserted cutter tools to a greater extent than formerly. This activity has been prompted largely by the high price of high-speed steel which has made it necessary to make the cutters only from this material, while the body and shanks of the tools are made of machine steel. Many experiments have been made to find the steels best adapted for a given service and the best heat treatment for the selected steels. Improvements have been made in the tangs of twist and flat drills adding strength sufficient to enable them to stand up to requirements of high-speed drilling and drilling machines.

Micrometers and Gauges.

During the past ten years the micrometer has become a measuring tool of general use. Almost every mechanic employed in up-to-date shops, who owns a kit of tools, regards a "mike" as necessary as calipers. Many shops also supply them from the tool-rooms on the workman's checks. As the result of the general use of the micrometer, one thousandth inch has become the unit of measurement for fixing limits, and a limit of one-quarter thousandth is not uncommon in grinding operations. Not only is there a great advantage in the matter of accuracy in the use of the micrometer over the old style of calipers set to a scale, but there is a considerable saving in time through their use, both in the matter of setting to size and in eliminating the element of uncertainty, permitting the workman to proceed with his work with greater confidence. So general has the use of this unit become, and so convenient is it for small dimensions, that a strong movement is under way to make it the standard for measuring wire, sheet metals, etc., in place of the irrational and arbitrary wire and sheet metal gauges. One of the largest electrical concerns abandoned the wire and sheet metal gauge systems in 1904 and adopted the decimal system, in which one thousandth inch is the limit for use in all specifications of wire, sheet metal, fibre, etc.

Standard length gauges have been improved. The so-called Swedish gauges are furnished under guarantee of error being not more than 100,000th inch, per inch length, the limit of error being proportioned to the length. Thus a gauge one-tenth inch long has an error limit of one-millionth inch, and so on; hence a stack of these gauges presents an overall length accurate to limit of one one-hundred-thousandth inch, per inch of length.

Screw Threads.

The so-called United States or Sellers standard screw threads have come into general use for machine construction during the past twenty or twenty-five years and have proven generally satisfactory for locomotives, cars, steam engines, and other typical heavy machinery but the automobile brought a new condition for which the standard threads were not well fitted. It was found that the jar and vibration to which motor cars are subjected, speedily loosened the comparatively coarse thread screws and nuts threaded to these pitches and the need of finer pitches was soon recognized. We now have the finer screw pitches established by the Society of Automobile Engineers, and the merits of these pitches have won them recognition in other lines of machinery where

the constructive reasons, pitches finer than the United States standard were desirable.

The A.S.M.E. standards for machine screws, which were adopted after a thorough investigation of the problem, should be mentioned also, in this connection. No work that this society has done is of greater importance than that of fixing on standards of screw threads to be recommended to the engineering profession.

Portable Tools.

An important factor in shop work is the portable electric motor drilling and reaming machine which has been developed in several efficient forms during the last decade. These portable machines, supplemented with the pneumatic riveting, chipping and caulking hammers, have virtually revolutionized shipbuilding, bridgebuilding, and structural steel work, and in the erection shop have wrought great changes, making possible rapid and efficient machine work on the parts as erected, and thus saving labor and time through the elimination of transport to and from stationary machines.

Power Hack Saws.

The first power hack saw machine was put on the market about 25 years ago. During the past few years the range and capacity of these machines has been greatly extended. They are furnished with quick return stroke, relief action for back stroke, means for using the full lengths of the blade, angle chucks and other improvements that have made this humble machine a real machine tool of high efficiency and low operating cost. Blades of great durability are furnished at low cost.

Brass Working.

The changes in brass working are principally in the development of automatic and semi-automatic machines for machining standard parts made in large quantities. Some of the machines have effected great reductions in cost, in some cases reducing the labor cost to one-fifth, or less, of that before the change was made. Carbon steel tools still have the call in some plants in preference to high-speed steel tools; carbon steel holds a keener edge and is generally more satisfactory for working the brass used in the manufacture of globe valves, cocks, etc. It is claimed, however, that much of the difficulty experienced in using high-speed steel on work of this character is due to improper heat treatment of the high-speed steel, and this contention seems to be borne out in practice as certain shops doing brass work of this character are using high-speed steel exclusively.

Chucks operated by compressed air have made a great improvement in the

operating efficiency of brass lathes. The work can be chucked and removed without stopping the work spindle, thus saving the time and strength of the operator. The development of the air chuck has taken place chiefly within the past few years, and it is one of the principal improvements made in hand operated turret lathes.

Manufacture of Guns and Pistols.

The methods of making guns, pistols and similar high-grade products have been revolutionized. A representative of one of the largest machine tool building concerns estimates that the efficiency of workmen in these lines has been doubled by the introduction of improved machinery and methods. When the fact is considered that high grade gun parts are made interchangeable, the limits of error allowed being very small indeed and that gun making is one of the oldest industries, the importance of the improvements made can be better appreciated.

Press Working.

Press working machines, punches, dies and other tools, have developed to an extent not generally realized by engineers in lines not affected. Here again the development of highly specialized methods of manufacturing automobiles has had a marked influence. Crank presses of 1,000 tons capacity are in use. Pressed metal forms of large size are a commonplace. Not only, however, has the development been remarkable in point of size, but also in detail of manipulation. Parts requiring several operations, for example, are turned out by multiple plunger presses, one finished piece being formed at every stroke. An interesting feature of press work is that shapes are produced impossible of duplication by any other known process. In this respect, press work differs from the most other machining processes; it is possible to duplicate, for example, lathe or planer work by hand tools, but not so many drawing and forming operations in daily use.

A branch of presswork little known is the extrusion of shells, tubes, collapsible tubes, etc., of copper, brass and alloys. Extrusion of bars in many shapes used in manufacturing locks, small machines, etc., has become a large industry which has been largely developed in recent years. The possibilities of extrusion are practically unlimited, and this process in common with other metal working methods extensively used has an important effect on the practice of shops using the shapes in their products.

Heat Treatment.

The advent of the high-speed steels and the alloy steels used in automobile gears, shafts and other high grade machinery subjected to shocks has neces-

sitated the development of furnaces and equipment for the scientific heat treatment of steel. Accurate determinations of quenching and annealing temperatures are absolutely necessary, and the pyrometer has become an indispensable instrument in the furnace room. Gas and oil furnaces have been greatly improved in the matter of efficient use of fuel and control of temperatures.

Die Casting.

The production of alloy castings in metal dies has grown to large proportions. Gears, bushings, bearings, type wheels, machine parts, covers, etc., are produced accurate to pattern and free from fins. This phase of manufacturing machine parts has a decided bearing on machine design. The extension of die casting to include not only the low melting alloys but also brass and cast iron, promises to make decided changes in some lines. Cast iron gears true to pattern on which machine work is reduced to the boring of the hub for the shaft, may become common in agricultural and similar grades of machinery.

Ball Burnishing.

Finishing processes are important in giving attractiveness to manufactured goods. Hand methods are slow and costly and the natural tendency is to use automatic mechanical methods for finishing as well as for making. One process of considerable interest because of its simplicity and effectiveness is the steel ball burnishing method, consisting essentially of a tumbling barrel partly filled with the articles to be finished and a mass of hardened steel balls of various sizes.

Thermit Welding.

An effective process has been introduced extensively during the period covered, for welding heavy sections of steel and iron. The thermit process is being successfully used for welding broken locomotive frames, cylinders, crankshafts, propeller shafts up to any thickness and diameter. The fractures are soundly united by a steel bond applied in situ at a fraction of the cost of removing the parts, welding them in the smith shop, finishing in the machine shop and replacing. Hundreds of locomotive frames have been welded by this process with almost uniform satisfaction and at a saving.

Autogenous Flame Welding and Cutting.

The development of oxy-acetylene and oxy-hydrogen welding and cutting torches has given the industrial world truly remarkable tools for building up or cutting apart. The welding of sheet metals is accomplished with speed and evenness hardly possible by any other process, and the cutting of steel or wrought iron is done close to the line

and with such rapidity as to equal or exceed the performance of any machine tool adapted for the same work. Recent improvements make possible the cutting all manner of shapes from steel plates up to 6 inches thickness so close to the outline of the pattern that a light finishing cut suffices to transform the piece into a finished die.

Cranes, Hoists and Trolleys.

The general provision of traveling cranes, jib cranes, hoists and trolleys in modern shops have made a great change in the manner of handling work and the attitude of mechanics to big jibs. When a casting weighing many tons had to be machined in the old-time shop it was a herelean job to transport it from one machine to another, and fix it in position. So general has the power traveling crane become in the past few years that it is a commonplace sight to see machine parts weighing many tons being transported through shops and placed on machines with no fuss and requiring the help of only one or two men besides the crane operator.

Accident Prevention.

The prevention of industrial accidents has received wide attention in industrial establishments. In machine shop accident prevention is a relatively simple matter, but there are a few points of danger which have become generally appreciated, and all of the better types of machines are equipped with guards to cover gearings, setscrews, flywheels and all moving parts necessarily exposed. There are also certain sources of danger which exist in practically all manufacturing plants and general rules to prevent accidents from slipping ladders, piles of easings, elevators, etc., are being applied.

General.

The following are enumerated without elaboration: Introduction of ball bearings in the construction of machine tools, effecting a saving of power, increasing the efficiency of operation, and capacity through reduction of bearing widths; development of cam grinding machinery and attachments making possible the rapid and economical production of camshafts having cams integral with the shaft; development of the dynamic balancing machine and the general recognition of the need of dynamic balancing for high-speed revolving parts; artificial production of highly-efficient abrasive or cutting particles for grinding wheels, and improvements in grinding wheel manufacture; development of improved lubricating systems for machine tool bearings; development of machine tools to their utmost capacity by providing means for working the tools all the time, employing extra men to prepare the work and also by tooling

the machines to bring them up to their highest productive capacity; development of spline milling machines for cutting keyways, key slots, drift holes, cam grooves, recesses etc., finishing square, hexagon and other shaped holes by the broaching process, insuring interchangeability and rapid production at low cost; general improvement in sanitary conditions of shops, improved lighting facilities both by day and by night through the use of saw tooth roofs, large windows fitted with metal window frames, improved electric lights and means of distribution; provision of lockers; and the establishment of shop restaurants in localities that formerly had nothing better than the corner saloon.



Peterborough, Ont.—Judgment for \$2,500 has been awarded the widow and child of Henry Ivon Fairweather against the Canadian General Electric Co. Fairweather was drowned while chopping away ice that prevented water getting to the machinery of the Nassau Power House on the Otonabee River, of which he had been appointed foreman on November 20th, 1911. He was drowned on January 14, 1912. His widow sued for \$10,000 damages. Mr. Justice Hodgins held that the company was negligent in not providing a railed platform from which the ice could safely be chopped away, and that contributory negligence was not proven.

Toronto, Ont.—Judgment for \$358 has been awarded G. E. Carveth against the Railway Asbestos Packing Co., of Sherbrooke, as damages for wrongful dismissal. He sued for \$2,596. He was employed by the company as its Ontario representative last March at \$2,500 a year. He moved his family from Montreal to Toronto, at considerable expense. The company terminated his engagement last August, as he alleged, wrongfully. He is awarded damages as above by Mr. Justice Middleton, whose judgment ran as follows:—I do not think there was any such incompetence or misconduct as would justify dismissal. The result was not as satisfactory as either Carveth or the company hoped for, and the company resolved to change the mode of carrying on its business by closing the Ontario office and concentrating its endeavors to obtain a foothold elsewhere. As a matter of business policy his was probably wise, but this did not entitle them to take the course they did with the plaintiff. The plaintiff's claim is exaggerated, and, I think, should be confined within the

bounds indicated at the trial, namely, for the period between his dismissal and the date when he secured other employment, plus the \$8 due him on expense account, in all \$358.

Milton, Ont.—The Coroner's jury on the death of Douglas Bradt, of Toronto, killed Feb. 14, by a fall from the top of the stand pipe of the Burlington waterworks system, returned a verdict that the deceased came to his death through the breaking of the hoisting apparatus, and in the opinion of the jury it was faulty. The contractors by whom Bradt was employed are the Toronto Iron Works.

Toronto, Ont.—Convictions were registered recently against the fifty odd Toronto Electric Light employees charged with digging holes by force, contrary to the civic by-law, by Magistrate Denison. The cases will be appealed to the Division Court. No sentences were imposed. The charges arose out of the action of the T. E. L. a month ago in erecting poles on Carlaw Avenue, a proceeding which the police vainly attempted to interrupt.

Quebec, Que.—Judge McCorkill, in the Superior Court recently rendered a judgment which possesses an importance to those under contract for supply of electricity. The plaintiffs in the case were the Quebec Railway, Light, Heat & Power Co., and they brought action against a hotel-keeper, suing him for the unexpired term of a contract for the supply of electricity by the plaintiff company. The defendant broke his contract, and later it was learned that he was being supplied with electricity from another source. The judge upheld in detail the contentions of the company in regard to unexpired terms of electric light contracts, and awarded the company the full amount of damages asked for and costs.

WHAT A FIRE CHIEF ADVISES.

Fire Chief Davis, Victoria, B.C., says: Stop the practice of tying electric drop wires by string or wire, and disallow paper shades to be placed around the bulbs.

At the closing hour, all windows should be closed, and all electric lights shut off except in hallways or stairways.

Place no inflammable material, paper, cardboard, cloth, wood, etc., near steam radiators or pipes.

Do not throw ashes of cigar or pipe, or the unburnt match, into the waste paper basket.

Place oily waste, floor sweepings and other refuse in a proper receptacle provided for the purpose, and see that they are emptied each day.

See that door over the switch and panel boards is at all times kept closed.

RAILWAY TRAFFIC IN NOVA SCOTIA.

THE report of the Provincial Engineer, dealing with railway traffic for the year 1912 was presented to the Nova Scotia Legislature on March 10. It shows that the total increase of traffic amounted to \$387,488.88, or more than 20 p.c. over that of the preceding year, and as last year's returns were 20 p.c. over that of previous years, this makes an increase of over 40 p.c. in the last two years. The returns for the last year show nearly one-half million passengers carried and over five million tons of freight.

Receipts and Expenses.

There was an increase of over 45,000 in the number of passengers carried, and about two million tons in the amount of freight carried.

As regards operating expenses, there is also quite an increase in some cases reducing the net receipts below that of last year. On the whole, however, there is a general increase in the net receipts as well as the gross receipts.

Comparing the receipts per mile of the railways in the Province with some of the larger Canadian Railway systems, it is found that the average receipts for the three Transcontinental Railways, are about \$8,000, while that of the Intercolonial Railway is \$7,000, and the Dominion Atlantic Railway, \$2,600.

Accidents.

The number of fatal accidents and the total number of casualties for the last year was greater than for any other year, with the exception of 1907 and 1911, but last year there was not one single accident to passengers. The greatest number of accidents is to employees, and while this is somewhat less than in 1911, it is considerably higher than other years.

Construction.

There has been no railway construction during the past year over which the Province had jurisdiction. The construction of the line from Dartmouth to Upper Musquodoboit, which was surveyed by the Provincial Engineer's Department, has been assumed by the Federal Government and been pushed vigorously during the past year. About the beginning of the year, the railway operated by the Nova Scotia Steel and Coal Co. between Ferrona Junction and Sunny Brae was taken over by the Federal Government, thus increasing the mileage operated by the Federal Government by 12½ miles.

The mileage of railway coming under jurisdiction is now 592, and the total mileage under operation in the Province is the same.

The Relationship Between Eyestrain and Illumination*

By Ellice M. Alger, M.D.**

Illumination of factories and workshops is not only conducive to quality and quantity output of product, but is highly contributory towards preserving the health and comfort of the operator as well. In addition to the provision made by the employer to secure the foregoing, the individual can and should cultivate the supplementary aid, due himself, and which only he is in a position to furnish.

EYESTRAIN is the common expression for that rather comprehensive group of symptoms which result from abnormal ocular fatigue. It results from compelling eyes to do work which is beyond their physiological capacity. Things close at hand are seen by a muscular effort of focussing, which, when long continued, produces a normal fatigue and requires a definite period of recuperation. If the eyes tire sooner than they should, because of some intrinsic weakness of ciliary muscles or because of a handicap imposed by astigmatism or increasing years, the fatigue is apt to manifest itself not only by defective vision, but by pain, and we speak of the condition as an accommodative asthenopia. The eye likewise sees things through the effect of light falling on a sensitive retina. If this light be overly bright or if the retina by reason of over exposure or disease is hypersensitive, the result is the disturbance of vision and pain which we call retinal asthenopia.

Results of Eyestrain.

The results of eyestrain are manifold and effect no two people exactly alike. They include pains in the eyes and many functional defects of vision and quite possibly often result in organic eye disease as well. They cause 80 per cent. of the chronic headaches. They result often in functional disturbances of other organs and in conditions of general nervous exhaustion and irritability. While most of the symptoms that result from eyestrain are of the accommodative sort, these are all capable of aggravation by improper lighting, and there are so many that are caused directly in this way that I shall invite your attention for a time to the relation between eyestrain and illumination.

Standards of Ocular Capacity.

In studying this relation, it must be remembered that there are few exact standards of ocular capacity. The average individual can see objects of a definite size at a definite distance, and this average is taken as a standard, but there are many who fall below this standard without obvious cause, and many who are far above the average. The varia-

tions in muscular endurance are still wider, for one man can work hour after hour at tasks which fatigue another in a very short time. The sensitiveness to light likewise varies widely in different individuals, both ability to see distinctly by faulty light and ability to work without exhaustion in strong light.

Concerning Light Effects.

Light is the reaction excited in the retina by the impact of certain vibrations or waves in the ether, which cause different sensations according as they are longer or shorter. The long ones give the sensation of red light, while, as they get shorter and shorter, one may see in succession all the colors of the visible spectrum. The mixture of all these wave-lengths together produce the sensation of white light; but the visible spectrum does not include all the waves by any means. There are longer waves than the red which cannot be seen, but can be felt as heat, and shorter ones than the violet, which have a very active chemical effect. It must be remembered too that both these quantities exist in the visible spectrum, the heating effects predominating at the red end, while the violet end approaches the ultra violet in its chemical activity. This enables one to explain some of the untoward effects of daylight on the eyes, even though daylight affords the best illumination for ordinary purposes.

Many of the effects of sunlight which were once attributed to heat are now known to be due to chemical activity. For instance, in snow and desert blindness, the light is broken up by reflection from the crystalline snow or sand, and the actinic waves produce intense inflammation of the conjunctiva, which, if long continued, results in total disability. Even in temperate climes, one suffers more or less from glare and burn from direct or reflected sunlight, and by common consent a good north light is taken as the standard of ideal illumination, being the steadiest, the pleasantest to the eyes, the best diffused, causing the fewest shadows and affecting color values least.

Natural and Artificial Light.

An artificial light can be broken up into its component parts, its spectrum compared with that of daylight, and its illuminating power measured by aid of

various photometers; but, so far, there is no artificial light which is just like daylight, though we are said to be getting nearer and nearer to it.

It has been shown by experiment that the light which gives the maximum of illumination with the minimum of irritation of the eye is composed of the yellowish rays from the middle of the spectrum. For this reason, the old fashioned candle and kerosene lights have never gone entirely out of fashion. Most of the more recent artificial lights, whether gas or electric, contain a much higher proportion of the short violet or actinic rays, and some of them contain many of the ultra-violet rays as well. When unshaded their chemical activity is so great that they can be used for various therapeutic purposes. They are capable of tanning the skin, and of causing symptoms of those of a modified snow blindness. Prolonged exposure to the electric arc light sometimes produces intense conjunctivitis with contraction of the pupils and erosions of the cornea. These fortunately, and generally, yield readily to treatment. Nearly everybody has experienced the discomfort and premature fatigue that comes from reading by unshaded incandescent lights. Even if they do not actually produce inflammatory changes themselves, they certainly render those already present decidedly less tolerable.

Causes of Cataract.

It is quite possible, however, that the delayed actinic effects of light whether natural or artificial are much more serious. The ultra-violet rays are arrested by ordinary glass, and in the eye by the tissues of the cornea and lens so that the deeper structures of the eye escape harm, but there is strong reason to suspect that their constant absorption by the lens may be one of the causes of cataract. Experimenters have been able to demonstrate lenticular changes in the eyes of rabbits exposed to such lights; and it is known that stokers and glass-blowers, who have to face very brilliant incandescent light, have a tremendous predisposition to cataract. This so-called bottle-makers cataract begins not in the anterior part of the lens, which should be expected if heat were the essential factor, but in the posterior portion where the rays of light are most concentrated. Other suggested observations are that

*Abstract of Paper read before the New York Section of the Illuminating Engineering Society on March 13, 1913.

**Professor of Diseases of the Eye, New York Post Graduate Medical School.

in the ordinary cataract of old people, the first changes generally occur in the lower inner quadrant of each lens which is the part least shaded by the brows and so most exposed to sunlight from above, and that when cataracts develop in people who have one light and one dark eye, it invariably appears first in the one unprotected by pigment from the light.

Even if the ultra-violet rays do not reach the deeper structures of the eye, one must not forget that the shorter waves of the visible spectrum have decided actinic properties. Many people have had their eyes permanently ruined by incautions watching of an eclipse, and similar damage sometimes follows exposure to electric flashes and even too long exposure to the arc light. In such cases, the light is condensed on the surface of the retina resulting in local inflammation and degeneration, that particular spot becoming permanently blind. Oculists suspect, though they cannot prove, that less intense and longer continued light irritation may be a factor in many similar degenerative changes in the retina and chorioid, and advise both for prophylaxis and treatment, the use of amber glasses and shades of such composition as to soften the light and exclude the actinic end of the spectrum. To people who are at all sensitive to light they are a great comfort.

The Pupil of the Eye.

Our north light is soft and even and well diffused, so that it causes a minimum of shadows. Artificial light to give anything like the same amount of illumination must be much more concentrated and intense. Now, the human eye even in natural light has to adapt itself to so many variations of intensity and dimness that it has developed a very beautiful mechanism for regulating the amount of light admitted to the retina. When the light is dim, the pupil dilates, and when it is bright, it contracts sharply. A sudden very bright light causes pain, not because the retina hurts, but because of this sudden extreme muscular contraction of the iris. Constant exposure to bright light necessitates constant muscular contraction and engenders in many people premature fatigue. Still more tiresome and painful is the rapid dilation and contraction of the pupil that results from the varying intensity of a flickering light. Furthermore, intense and long continued exposure to bright light causes retinal exhaustion and the retina is capable of reacting only to powerful stimulation. In other words, that retina becomes for the time being blind except in the brightest of lights.

Everyone has experienced the comparative blindness caused by going from

bright sunlight into a dimly lighted room. It is a common experience to have workmen insist on having as intense a light as possible because they have temporarily so blunted their retinal sensitiveness that they are helpless without it, and it is generally the hardest kind of a task to convince them that even if they suffer no harm from the glare, they cannot possibly work as long without fatigue. In another set of people, the retina instead of being blunted becomes hyperesthetic and finally almost incapable of bearing any exposure to light at all. This condition is seen at its worst in hysterics, when it is of course not a result of over lighting, but there are a number of occupations like those of gilders and polishers who have their attention fixed for long periods on bright surfaces, in which retinal asthenopia is very common. Furthermore, daylight has a vast volume, and is diffused so that objects get light from all sides, and shadows are reduced to a minimum. Artificial light can hardly be expected to secure thorough diffusion and more than comparative freedom from shadows, but in many industries almost no attention has been paid to this point. It is very important, however, for Calder in a very interesting paper has shown that the retinal anesthesia and deep shadows which result from poor artificial lighting are potent factors in causing industrial accidents.

Daylight and Accidents.

The records of some 8,000 manufacturing plants over a period of three years showed a regular minimum of accidents during July and August, which gradually increased to a maximum in the dark winter months. The influence of daylight in preventing accident was much more evident in occupations which require not so much bright light as diffused light without shadows over large areas, as in the building trades for instance. Indoor workers as often suffer from too much light as from too little. Exact photometric measurements may show that the light of ordinary incandescent lamps concentrated at the cutting point of a tool or a work-bench is several times the intensity of daylight; but the eye adapts itself to this intensity, and when the workman turns from his over-lighted work, perhaps in a room full of moving machinery, he is practically blind. What is needed from the point not only of safety but of health and comfort is much less intensity and much better diffusion of light. This applies to all walks of life. We have all become accustomed to using far more intense light than we need.

The Eye the Best Measure.

One can measure the amount of illumination, by photometers which are

much more accurate and dependable than the human eye; but, after all is said and done, the eye is one of the best of photometers if one is careful not to injure it in the process, since it is upon its adaptability to that eye that all artificial lights must stand or fall. One should begin with a low illumination and gradually increase it till a point is reached when further increase ceases to improve the details of the work in hand. Beyond this, an additional light is both unnecessary and physiological extravagance.

Abnormal fatigue is admittedly one of the greatest predisposing causes to most diseases be they physical or mental, and though the part played by bad lighting is perhaps not clear cut, it is beyond doubt, that in most factories, schools and offices, the eyes must be used constantly for work of a character they were never intended for. The result even in normal eyes is a muscular and nervous fatigue which is measurably increased by both over or under-lighting. The first engenders fatigue from retinal exhaustion and pupillary spasm, while the second results in the strain that follows sharp focussing and constant attention. In the majority of individuals whose eyes are handicapped by astigmatism or other refractive errors, the strain is still greater. It is unnecessary here to detail the long list of conditions of health which have been attributed to eyestrain; some of them being beyond dispute, while others are open to question.

Over-Lighting and Nervous Exhaustion.

The over-lighting which is so common to-day may conceivably have other effects. Woodruff has shown that in the tropics, blondes who are unprotected by skin pigment are over-stimulated by the bright light and finally develop a characteristic nervous exhaustion. Again, it is quite possible that eyestrain and the constant exposure to intense light of short wave-length may be predisposing factors to the neurasthenia from which our garment makers admittedly suffer.

Arrangement of Lights.

The arrangement of lights as well as their composition and intensity is of importance. It is well known how uncomfortable it is and how much it interferes with clear vision to have a bright light shining directly into the eyes, and lights which enter the eye from below are much more annoying than those from above. In face of this fact, how often are machines so placed that the operator has to face a window or a light. The same difficulty occurs in trades like those of gilders and polishers who have bright lights reflected into the eyes from their work, and in schools where the smooth shining pages of the books answer the same purpose. As far as pos-

sible, light should fall from above, behind and to one side. The light should be sufficient for the work in hand, should throw no shadows on it, and should be reflected not into the eyes of the workers but to one side. When it comes to the arrangement of light for many workers in a factory or school, the problem is very much more difficult and presents many technical details, which must be left in the hands of the illuminating engineer. Even when estimated by its actual cost in dollars and cents, bad lighting is often more expensive than good, but from the standpoint of efficiency there is no comparison.

Bad Lighting Expensive.

Bad lighting undoubtedly causes unnecessary strain of the eyes and consequent premature muscular fatigue; it compels closer and more constant attention to the details of work, so that tasks which should be done almost automatically and without mental effort are done consciously. Under such circumstances, the output of each individual is manifestly less than it should be, there is a larger percentage of mistakes and material spoiled, and the number of accidents, large and small, is vastly increased. Even under the best conditions, the extreme subdivision of factory work with its consequent monotony, largely destroys the pleasure of work, but bad eyes and poor lighting and long hours are important factors in the industrial discontent of the day.

It goes without saying that any system of scientific shop management worthy of the name implies a good lighting system as one of the first requisites, but as yet opinions vary widely as to just what this means. It is possible to regulate the color and composition of the light that enters the eyes by the interposition of screens or shades which shall absorb the rays one does not wish to use, or by having it reflected from suitable colored surfaces. The volume and intensity of light can be regulated by increasing or diminishing the number of units, and by diffusing it with frosted shades, or by reflecting it from rough surfaces: but while the experts are agreed on the principles involved, they do not agree entirely on the details. The human eye is flexible enough to adapt itself to very wide variations in illumination but there must be comparatively narrow limits within which the greatest efficiency may be reached. Quite possibly different industries may require entirely different types of illumination, and while these may be worked out in detail in the laboratory, they must all be subjected to the final test in the shop or school.

Science of Illumination.

Illumination as a science is yet in its infancy. Even in great public buildings, libraries, and theatres, it is treated not as an essential but simply as an aid to the proper display of the genius of the architect or the taste of the decorator, and if such buildings are badly done, one can hardly expect as yet that any great attention will be paid to the proper lighting of the ordinary factory or house. Every one admits to-day that the State must control factory conditions so far as they effect the health and well being of employees, and many attempts are being made to deal with the subject of illumination by law.

It is an extremely difficult subject to handle in this way; even the experts are not agreed on many important points. What would be good lighting in one industry might be the worst possible in another, and to make drastic regulations in the present state of the art would often involve manufacturers in great expense in changing their light equipment without any guarantee that it would be permanently satisfactory.

After all, good lighting is essential to the efficiency of both employer and employees, and a judicious campaign of education will make them both appreciate it. Then too, there are numerous large and powerful corporations engaged in various branches of the lighting industry, and there is perhaps little danger that the subject will be allowed to be forgotten either by consumers or legislators.

QUEBEC MINERALS.

THE Mines Branch of the Province of Quebec has just issued a preliminary report on the mineral production of the Province during the year ending December 31, 1912.

The figures given in the report are very interesting. The total value of the products of the mines and quarries of the Province during the past year amounted to \$11,017,046.00, the largest annual value yet recorded. This is an increase of \$2,337,260.00, as compared with 1911, when the production amounted to \$8,679,786.00. It is a very creditable showing and reflects the general prosperity of the country. As a point of comparison it may be mentioned that in 1892, just twenty years ago, the total mineral production of the whole of Canada amounted to only \$16,625,000.00, to which the Province of Quebec contributed probably a little over one million dollars.

The principal products of the Quebec mines, according to the statistics just published, are asbestos, copper ores, mica, graphite, which together make up

35 per cent. of the production. Structural materials such as limestone, granite, cement, bricks, marble, account for some 60 per cent.

The growth of the mining industry in the Province of Quebec is well illustrated by a table which is given in the report. In ten years, the total value of our mineral production has increased from \$2,772,762.00 in 1903, to \$11,017,046.00 in 1912.



EVERY BRASS FOUNDER SHOULD KNOW.

THAT blowholes and pinholes in castings are produced by the same thing. Blowholes are only large pinholes.

That blowholes in castings are nearly always caused by overheating the metal during melting.

That metal that has been overheated and then cooled down to the right pouring temperature is not as good as that which has been heated only to the right degree and requires no cooling down.

That aluminum and aluminum alloys require pouring at a low temperature in order to obtain sound and strong castings.

That composition and brass require pouring at a much higher heat than aluminum and its alloys in order to obtain good castings.

That tin hardens the brasses and bronzes, and that the more they contain, the harder they become.

That lead causes the brasses and bronzes to cut freely, but an excess weakens the castings and is apt to separate out in spots.

That iron, when chemically combined in brass or bronze, has the same effect as tin, and hardens the metal; otherwise it has no injurious effect and cannot be noticed.

That iron, when not chemically combined, separates out into small, extremely hard shot, which injures tools when the castings are cut or drilled.

That phosphorus and zinc do not agree. If phosphorus is used in brass, composition or bronze containing zinc, it should be in very small quantity, not over one or two hundredths of 1 per cent. (0.01 to 0.02 per cent.). If a larger quantity is used, pinholes will be present in the castings.

That castings always come cleaner when poured from the bottom. This applies to large and small castings.

That metal containing aluminum, such as manganese-bronze, aluminum-bronze, etc., requires a long gate to obtain a clean casting. Aluminum oxidizes upon exposure to the air and the metal containing it becomes "drossy" as it runs. A long gate retains this dross and it does not enter the casting.

The Determination of a Man's Natural Aptitude *

By Harrington Emerson

It is becoming increasingly recognized that all men can fill one position to a greater degree of successful achievement than they can most others, and that the low general average efficiency, everywhere apparent, is due wholly to a high percentage of misfit employment, to combat which, those responsible have made little or no effort.

MORE than three-quarters of the industrial workers, including executives, do not have natural aptitude for the positions they fill, yet it is a simple matter to predetermine both the inherent ordinary and extraordinary capacities of either and to place both in positions to suit their individual qualifications.

Considerations Embraced.

The yearly money loss in direct cost on the average machinist of only 30 per cent efficiency (not by any means an unusual standing), is nearly \$5,000; omitting the loss of profit on output. This loss from inefficiency increases as the position becomes one of greater importance. The industrial loss from the ill adjustment of workers to their duties is only a small part of the total loss. Ill-assorted marriages are a phase of bad adjustment, improperly educated children another.

The value of the individual who is competent increases far more rapidly than his market price. Even in rough labor, the type of man that 8-hour day and 35 cents per hour pay can secure is more economical than the 20-cents per hour man, working 10 hours. If positions were filled by men fit for them, if wages were paid necessary to secure men who were fit, difficulties between employer and employee would be inconceivable.

The Executive at Fault.

In a long experience we have always found the so-called employer, the executive, at fault. He has filled the positions in his plant with ill-qualified men, because he did not know how to secure competent men, was not able to compute their wage value and was unwilling to pay any advance on the current rate to badly placed men. The vocational counsellor is, like the musician, born with an aptitude which can be cultivated and trained in a scientific manner, resulting in great skill. If either natural gift or scientific training is lacking, the result is mediocre. A paleontologist can reconstruct, from a single tooth fragment, the animal to which it belongs, including its general disposition, and how much easier, then, is it from all the external indications of a living animal, to determine its characteristics.

Since man reveals himself in many ways the animal cannot—by his clothes, by his handwriting, by the fatal gift of speech—it is remarkably easy for those who have supplemented natural ability by comparative study to read accurately all the natural aptitudes of any man or woman. For instance, since the brain, spinal chord and whole nervous system are formed from an unfolding of the surface skin, it of necessity follows that the texture of the skin indicates the texture of the brain and nervous system; therefore, in speaking of the character, we use the expressions "thick-skinned" and "thin-skinned."

As nearly all men lack standards, and as many men mistake the effort of incompetence for the achievement of genius, we cannot be guided by any man's estimate of himself. The young are particularly given to taking hold of what is distasteful because they enjoy the struggle, the effort. It is, therefore desirable that the position should be given the right man, and that the man should not receive the position he wants or likes. The qualities required for the best administration of every position should be specified. It may take more than one man to possess the qualities, for which reason some men succeed better in partnership than they would do singly. The partners complement each other.

Aptitude and Experience.

Aptitude is more important than experience. Men with aptitude can be given experience, and they learn with extraordinary rapidity. A man with aptitude can learn a trade in a few months. A man without it never becomes a skilled worker. In giving a man of aptitude, experience—that is, educating him, his own peculiar qualities determine the form of education best suited therefor, the man is not warped to suit the method of education. Some men learn through the eye, others through the ear, others through the muscles. Some learn best under one kind of a man and some under another kind of man. The fitting of man to man is as important as fitting man to position.

Plan for Industrial Employment.

As a rule, those who are not identical, yet not very far apart in temperament, work better than those who are identical or very far apart. A trotting horse does

better, not in double harness, but with a running mate who is just a little faster. He would not succeed if harnessed either with a donkey or with a fast runner.

Our general plan for industrial employment should be:

a.—To establish a thoroughly competent and complete employment department.

b.—To employ, assign, transfer, promote and discharge solely through this department.

c.—To specify the required qualities for every position.

d.—To establish wage classes. The man belongs to the class in which his hourly rate locates him.

e.—The rates for certain positions should be determined by the price that has to be paid to secure men of full qualification for the positions. We should vary the rate of pay to secure standard ability. We should not vary the requirements as to ability in order to adhere to standard rates of pay.

f.—Full efficiency, full punctuality, full reliability for a specified period entitle a man to advance into the next highest class and corresponding change of work. The only limits to a worker's advance are the limitation of his own ability and the shortage of positions for which he is competent.

g.—Failure to attain high efficiency is prima-facie evidence, not of incompetence but of bad placing. Bad placing is very rare if the employment department is competent.

h.—The personnel of a man's surroundings are as important as the work. Personal aptitudes count for as much as work aptitudes.

i.—The teacher and the teaching should be adapted to the learner.

POWERFUL AUTOMOBILE TRACTOR.

WHAT is said to be the most powerful and the heaviest automobile in the world has been placed in service by the Pennsylvania Railroad Co. at Jersey City, N.J. It is a tractor for hauling freight cars between the company's station and a pier two blocks away. It will take the place of 8 heavy draught horses formerly employed for this work. The machine, which weighs 28,850 pounds, and measures 22 feet long and 8 feet 6 inches wide, was built in the Altoona, Pa., shops of the railroad from the designs of one of the company's electrical engineers. The tractor is operated by electricity, and is provided with 80 storage batteries capable of supplying sufficient current to last for 40 hours without recharging.

*Abstract from the Bulletin of the Efficiency Society, N.Y.

THE HUDSON BAY PORT PROJECT.

THE Canadian Government intend early in the spring to take active steps to render the entrance to Hudson Bay easy of navigation by large steamers. Lighthouses are to be built, buoys laid down, and various important works will be undertaken at Port Nelson, Fort Churchill, and along the Hudson Strait. A careful survey of the whole district has been made, and recommendations will in due course be submitted to the Department of Marine. As most of our readers are doubtless aware, there is to be a railway from the wheat district of Saskatchewan to Fort Churchill, and the advocates of this route claim that it will provide a ready and cheap outlet for grain.

Many people able to speak with authority maintain, however, that the Hudson Bay route can never be made a successful proposition. The season of open navigation is, they declare, too short to enable any large proportion of the annual harvest to be shipped; elevator storage would be far more costly than, say, at Port Arthur or Fort William; and

Liverpool to Montreal	2,990
Montreal to Vancouver	2,906
	—
Liverpool to Vancouver	5,896

As far back as 1886, the Dominion Government despatched an expedition to investigate the navigability of Hudson Strait for commercial purposes, and the verdict of the commander, Lieut. Gordon, was scarcely encouraging. "Altogether," he wrote, after making some general observations on the navigation of Hudson Strait and Bay, "I consider the navigation of Hudson Strait as being more than ordinarily difficult, with shores inhospitable and bleak, presenting such a picture of loneliness and desolation that it takes some time to get accustomed to it. The only safety in thick weather lies in the constant use of the lead and keeping a bright look-out, as the dead reckoning is frequently in error to a considerable extent." Later, he expresses the opinion that a ship-owner who permitted his vessel to enter the Bay before the middle of July would be subjected to such delays as would add very seriously to the cost of

against foreign-made articles. The demand is so large, however, and is continually increasing, that there will be plenty of trade for foreign manufacturers for a long time to come. A Russian-made reaper contains on an average 21 to 22 poods of metallic parts (1 pood being equal to 36 lb.) and about 4 poods of wood. A reaper from the Phoenix works in Riga is sold at a price of 165 roubles, similar American machines being sold at 155 to 160 roubles. The raw material of the reaper will cost some 2 roubles per pood, or altogether about 50 roubles; half the cost of the raw material is paid in State premiums, or fully 15 per cent. of the sale price. The portable engines used in Russia weigh about 500 poods, those from the Madstewska works, for instance, weigh 465 poods, and are sold at 3850 roubles. The premium for this engine is about 14 or 15 per cent. of the sale price. The German firm of Lanz sells a considerable number of threshers in Russia; a 12-horse-power thresher weighs 370 poods, and costs 2850 roubles, sold by itself. The price may be somewhat less if sold together with an engine.



MOUTH OF THE NELSON RIVER NEAR PORT NELSON.

the interest on capital locked up in wheat at Hudson Bay from October in one year to August in the next would be another very serious consideration. Then, too, it is probable that the premiums on vessels using the Hudson Bay route would be on such a scale that they would more than counterbalance any saving which might be effected in the cost of transportation. The new route would, of course, shorten the distance between Western Canada and the United Kingdom: in fact, as the following table shows, the actual reduction on a journey from Liverpool to Vancouver would be 1,328 miles:—

	Miles.
Liverpool to Fort Churchill	2,926
Fort Churchill to Calgary	1,000
Calgary to Vancouver	642
	—
Liverpool to Vancouver	4,568

the voyage; while any vessel leaving the Bay after the middle of October would be faced with grave risk of becoming ice-bound.

The fact that the Hudson Bay route is to a large extent a pawn in Canadian party politics has tended to cloud the issue from a purely commercial standpoint, and, consequently, it is difficult to discover what are the real merits, if any, of the scheme.

AGRICULTURAL MACHINERY IN RUSSIA.

IT will be noted from the following particulars that the premiums granted by the Russian State to home manufacturers of agricultural machinery, etc., are by no means inconsiderable, and are of such an order that they must materially assist the Russian makers in their competition

The premium for a thresher of this weight will be 370 roubles, or 13 to 14 per cent. of the sale price.

Mr. R. H. Merriman, who has been connected with The B. Greening Wire Co., Ltd., for a great many years, and was secretary and a director since its incorporation, has resigned as regards active connection with the firm. Mr. Merriman, who is one of the best known men in the hardware trade of Canada, will carry with him the very best wishes of his many friends as well as the kindest regards of the firm with whom he has been so long connected. We understand that Mr. Merriman has decided to go into the agency business and will handle a line of hardware that will keep him in touch with the trade. We understand he retains his financial interest with the B. Greening Wire Co.

The Close Relationship Between Friction and Lubrication

By Joseph Hayward, M.Sc.

There is a good deal of vagueness existent in many people's minds regarding this subject, due largely to the fact that they overlook the fundamental difference in the nature of friction between unlubricated and lubricated surfaces. The writer of the article deals with the matter in a practical manner at once easily intelligible and brimful of instruction.

IT is well known that the resistance to motion between dry surfaces depends upon:

(1) The total pressure between the surfaces. This, however, is slightly greater for large areas and small pressures than for small areas and great pressures, provided always that the pressure is not great enough to indent or otherwise destroy either surface.

(2) The speed at which one surface moves over the other. Except at very low speeds, the resistance decreases as the velocity increases.

(3) The nature of the surfaces. Relations 1 and 2 hold good for clean, solid surfaces only, but they may be applied to surfaces "filled" with a so-called solid lubricant such as graphite or mica,

the surfaces themselves are correspondingly smooth and accurately finished. Wear of moving parts may be entirely prevented by complete lubrication with a good, clean lubricant, for their metallic surfaces will never come into actual contact with one another.

Friction Between Lubricated Surfaces.

The friction between lubricated surfaces is, naturally, not directly dependent upon the nature of the surfaces, since it is assumed that they do not touch, nor does the resistance vary with the pressure. The latter statement is borne out by the familiar fact that the frictional losses in a steam engine are nearly the same at full and at light loads—i.e., an engine that indicates 100 h.p. and gives $100 - 20 = 80$ effective horse-power, at full load, will still indicate 30 h.p. when the effective horse-power is only 10. Another difference is that with lubrication friction increases with the speed instead of diminishing. The increase is most marked at moderate speeds.

Forced Lubrication .

The most satisfactory way of insuring proper lubrication is by the use of a pump to force the lubricant between the surfaces to be separated. In certain cases, such as the heavily loaded collar bearing sketched in fig. 1, a force pump must be used. In other cases the tenacity with which oil clings to a surface which it has once covered, and its viscosity or resistance to rapid flow, may be relied upon to keep the metal faces apart. For example, fig. 2 shows a fresh drop of oil upon a guide bar. When the crosshead reaches this, as

shown in fig. 3, time does not allow of the oil being swept off completely, an enormous pressure being necessary to do this. The only alternative is for the moving face to rise and pass over a bed of the lubricant, and it is easy to see that the thickness of this bed will depend upon:

(a) The speed at which the cross-head moves.

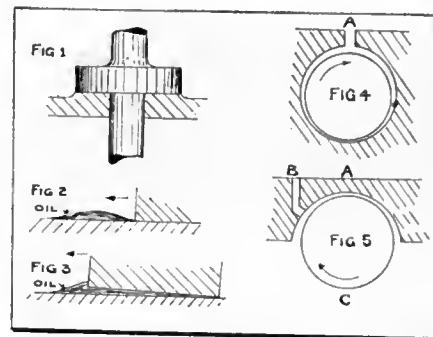

FIGS. 1 TO 5. FRICTION AND LUBRICATION.

(b) The pressure between the surfaces.

(c) The viscosity of the oil.

The resistance to motion or friction increases with the viscosity of the oil used. Therefore, it follows that as thin an oil should be used as will maintain a sufficient separation of the surfaces at the speed and maximum pressure to be provided for.

Fig. 4 shows a loaded shaft resting in a bearing, the difference in diameter between the two being much exaggerated. A drop of oil falling on the shaft at A will be drawn round with it to the point of greatest pressure at B, and will separate the surfaces there.

Fig. 5 shows a loaded bearing resting on a shaft. In this case the only way to supply oil at A would be to force it in under pressure, but it might be dropped from a lubricator upon the moving surface at B, or rubbed upon it

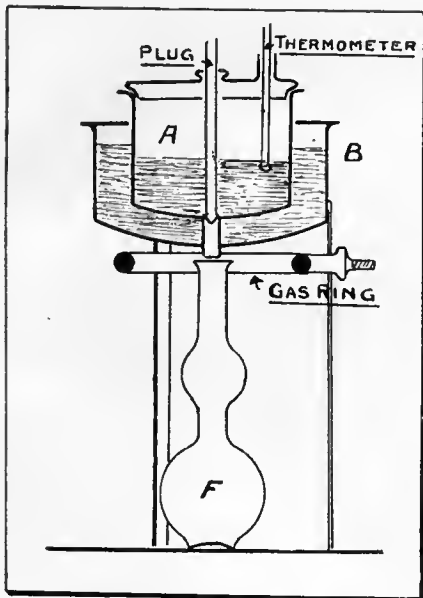

FIG. 6. ENGLER'S VISCOMETER.

or with a film of grease so thin that it acts like a solid coating.

In the power house we have little to do with dry friction, except to take advantage of it in rope and belt transmission and in friction clutches. In these cases the object is to provide sufficient resistance to prevent relative motion altogether. Where there is a relative motion, as in all parts of our running machinery, complete lubrication should, and in many cases can be, obtained. By complete lubrication is meant a separation of the solid surfaces by a continuous film of oil, which, however, may be thinner than a thin sheet of paper if

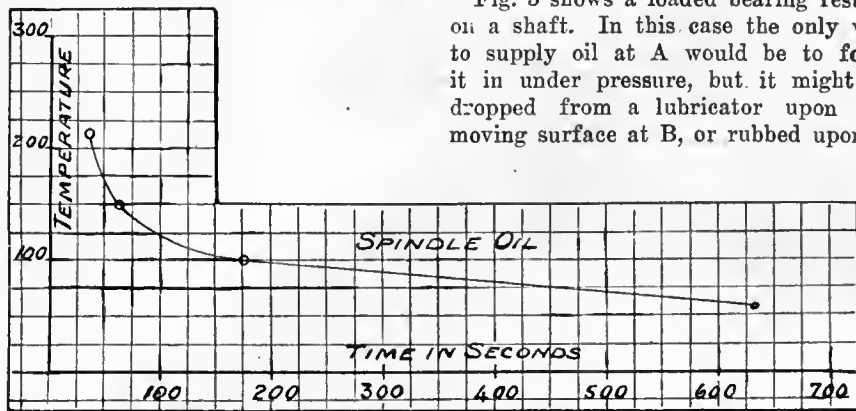

FIG. 7. FRICTION AND LUBRICATION.

by a saturated pad at C, the latter being the method used for lubricating railroad axles. From the foregoing the importance of using a lubricant of the right viscosity will be understood.

Viscosity of Oils.

The viscosity of all oils changes with temperature, and the temperature of a bearing, except where it is cooled by water circulation, depends upon the frictional losses within it, and these again are proportional to the viscosity of the lubricant; hence it is useless to make a dogmatic statement about the correct oil to be used. This is a matter of experience. The viscosity of some oils is reduced by heat far more rapidly than that of others. Thus, of two oils equally thick at atmospheric temperature, one may remain a useful lubricant and the other be little better than water at the temperature of a steam engine cylinder.

The comparison of viscosities at various temperatures is a simple experiment which any engineer can carry out for himself with an inexpensive apparatus called a viscometer, a sketch of which is shown in fig. 6. An inner chamber (A) is enclosed on a vessel (B) filled with water or oil. This is heated by a gas burner to any desired degree. There is a small hole in the bottom of chamber (A), closed by a plug. The chamber (A) is filled to the level of a mark upon the side with a sample of the oil to be tested. When the temperature of the sample has become steady, the plug is removed, and the time taken to fill a measured portion of a flask (F), placed beneath the orifice, is noted. This is taken as a measure of the viscosity of the sample. The time of passage of the same quantity of clean water at atmospheric temperature may be taken as a standard of comparison, and the test should be made from time to time to check any alteration in the orifice. It is important that the vessel and orifice should be thoroughly cleaned with alcohol and dried before introducing a sample of different oil.

When testing an oil at various temperatures, it is convenient to record the results graphically, as shown in fig. 7.

COAL MINING IN NOVA SCOTIA.

By W. J. B.

CONSERVATION in the mining industry has been developed to a greater extent in Nova Scotia than elsewhere in Canada. In connection with the coal mining industry, in that province, the following is worthy of note:—

The coal lands are disposed of under a leasehold system, the period being 20

years (except in special cases), with the option of three renewals, making in all 80 years. Under these conditions there is little incentive to fevered haste to rob and ruin valuable coal seams, and more care is exercised in gaining a thorough knowledge of the conditions of coal occurrence, that the method best adapted to its extraction may be determined. The long period lease also gives confidence to capital and permits larger outlays to be made, in order to prevent as little waste as possible in the mining and utilization of the coal.

Government Approval Necessary.

The method of mining to be adopted in the different districts is generally understood, and, before a mine can be developed, or a new section of a mine opened up, it is necessary that the plans be submitted to, and meet with the approval of, the Department of Mines. In addition to this, the Government requires all operators to make yearly returns showing the extraction obtained, etc. The information thus secured is not only of value in determining the rate of exhaustion of the coal-fields, but also allows a comparison of the methods and tends to standardize the methods employed. As a result of the systematic manner in which mining is carried on in Nova Scotia, large sections of coal have been mined with but very little loss.

With regard to the order in which coal seams are worked, it is the practice generally to mine the highest workable seams first and to leave large pillars in advance work to support the weight of the superincumbent strata. Where superimposed seams are worked contemporaneously, the work in the upper seam is kept well in advance of the lower, and pillars are never drawn in the lower seam until all the pillars in that section of the upper seam are removed and the roof has been allowed to settle.

Precautions in Submarine Mines.

Submarine mining is carried on to a considerable extent in Cape Breton, and, with the exception of the flooding of the mine at Port Hood, no accidents have occurred and no coal has been lost. Generally speaking, few submarine pillars have yet been extracted, but the pillars left are of such dimensions that it will be possible, where sufficient cover exists, to recover these pillars in retreat after the boundaries of the mines have been reached. Where seams of usable size and quality extend seaward beyond the limits of a submarine property, drawing the pillars should be forbidden. If the company's lease does not provide that the pillars be left in place, compensation for the pillar coal should be made.

In the Picton coal-field the conditions are not so favorable for the high extraction of coal as those met with in Cape Breton coal areas. This is due to the thickness of some of the coal seams being such as to make it impossible to mine all the seam at one lift; also the high dip of the seams quickly increases the depth of cover over the workings, and, as the workings extend to the dip, timbering, haulage, pumping and ventilation problems are made more difficult. To the above may be added the fact that some of the seams are liable to fires, due to spontaneous combustion; also, the top bench of the coal seams in several of the mines has been removed a number of years ago.

Notwithstanding the above mentioned disadvantages, the top coal and the bottom coal which had been previously left in the mine is now being recovered so far as is economically possible.

EFFICIENCY IN LABOR.

WE are the most efficient people in the world, yet are but beginning to be efficient, says "The New Industrial Day." We have yet to learn to utilize the brains of our workers as we utilize their hands. The best plants anticipate and avoid waste so far as may be by designing, making, operating and protecting their machinery in accord with the laws of its being. When we treat our men in the same way, using each of them at the work he is fitted to do, training each in mind and hand to use efficiently the best appliances under working conditions that develop his mental and physical manhood, then we shall save human waste and reach a quality and quantity of product that will free us from all doubts of our power to meet on equal terms the men of any land. So long as we look first at the wage rate, and the past or present costs, instead of at the product rate and the possible cost, we shall all be cowards.

Change in Philosophy of Labor.

There must be change in our philosophy of labor. We must learn the difference between cheapness and economy. We may think well to crowd our machinery to its limits and scrap it in a few years because a new invention shall have then replaced it; but we must learn not to crowd men that way, for we cannot scrap men. The man can grow, the machine cannot, and we must be sufficiently scientific in our management to avail ourselves of the growth of the man. We must deal with inefficient labor by teaching it, and by paying it enough to stimulate it into efficiency.

On Welding and Cutting by the Oxy-Acetylene Process

By C. W. Byers

In the past, welds have been made by the blacksmith. The writer of this article tells in detail of a new method fast coming into use, which will be revolutionary in the width of the field it covers. Moreover, this oxy-acetylene flame, with a heat of 6,300 degrees F., has remarkable cutting powers, being capable of severing a six-inch steel shaft in six minutes.

WHETHER machinists like it or not, they must admit that the method of welding and cutting metals by the oxygen-acetylene method has proved itself within the past few years to be a marked advance, and if they are generous and frank they must admit that in a few years more the oxy-acetylene flame will have revolutionized the machinist business as far as repair work is concerned.

When a system comes into being which will save valuable pieces of machinery, which hitherto were lost, there is bound to be a demand for it. That is what is taking place in Canada and

the parts to be joined, and by adding fused wire as the metal is reduced to a molten state. Welds were hitherto made mechanically in a blacksmith's

boiler plate, or the fracture of an expensive brass vase, may be repaired with the least possible trouble and expense.

The apparatus described in this article is one of many made in America, but it is that of a pioneer in the business, and is proving successful wherever used. The welding works of the Siche Gas Company, Ltd., are at 176 Richmond Street W., Toronto, with head office at 10 Lombard Street. They manufacture the Oxyweld equipment.

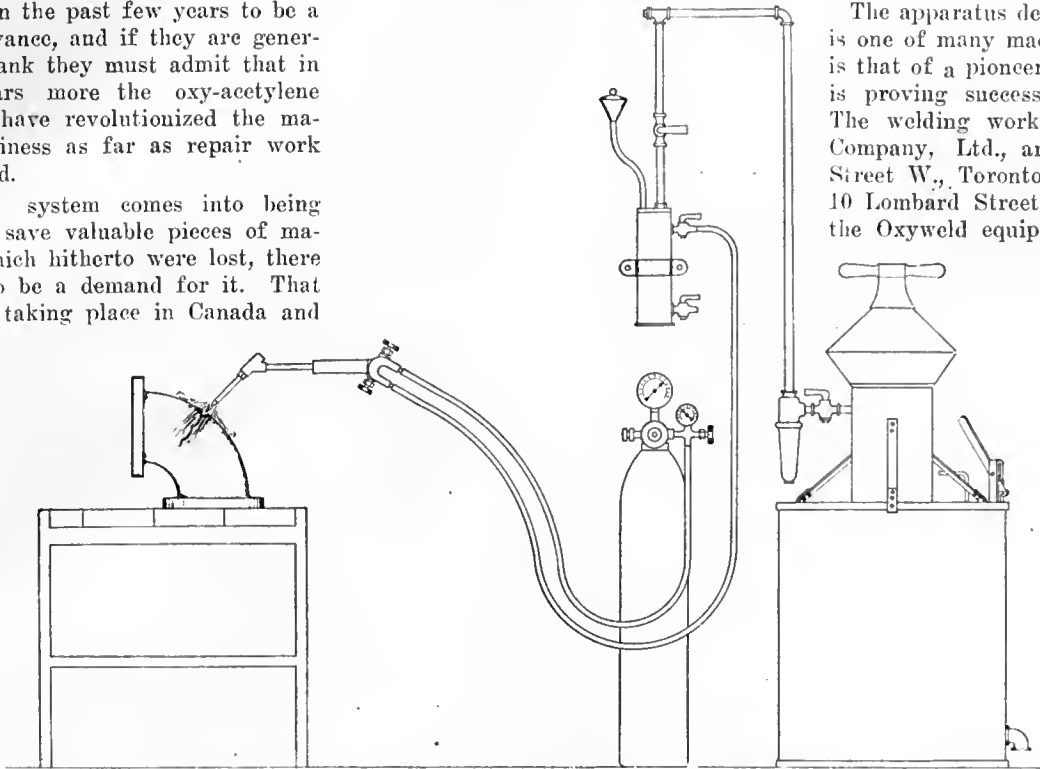

FIG. 1. A COMPLETE OXYWELD EQUIPMENT.

The plant consists of: 1. Siche gas generator (special welding type). 2. Hydraulic back-pressure valve. 3. Oxygen pressure regulator, indicator, and oxygen bottle. 4. Hose. 5. Torch. 6. Iron table with fire-brick top.

all over the world. Blacksmiths and small machine shops are installing the apparatus, and big concerns are using it when necessary, and later will find it as indispensable as a file or a lathe.

So little is known about this system of welding, a description of the apparatus employed should be of interest. First of all, it should be understood that welding by the oxygen-acetylene method is the uniting of metal without the use of any foreign substance, giving a perfect joint. This method has been used for years under the name of "lead burning," but its application to steel, cast iron, brass, etc., has only been adopted in recent years. This has been made possible by the oxygen-acetylene flame, which gives a temperature of 6,300 degrees Fahrenheit.

Making a Weld.

A weld in iron or steel plate is made by applying this flame to the edges of

forge, which limited the use of a weld. By the new process a broken piece, say, the lug of a casting, or a crack in a

This is remarkably simple in construction, as will be seen by a glance at Fig. 1. On the right is the acetylene



FIG. 2. CUTTING 6-INCH SHAFTS IN 6 MINUTES.

generator made of galvanized iron. The lower tank contains water; the upper section, which carries the carbide, as it proceeds into the water assumes a bell shape, the edges of which nearly touch the side of the tank. When the gas is being used, a float in the dome-shaped chamber operates a check valve, allowing the carbide to fall in small quantities into the water. The gas is generated, and forces the water upwards in the outside tank, the gas itself proceeding to the operator's torch. Thus a gasometer is entirely unnecessary.

Cleansing the Acetylene.

The gas in its course passes through the supply of carbide, relieving itself of all water; then through a wool dust arrester, which takes away the amorphous lime powder. It then proceeds to the torch by way of the hydraulic back-pressure valve. This piece of apparatus is used to prevent gas from striking back through the torch to the generator. It consists of a water seal, and is supplied with all Oxyweld equipment. In the centre of Fig. 1 is the oxygen bottle, with pressure regulator and indicator.

Here, then, are the two sources of gas—the acetylene and the oxygen. They proceed along separate tubes to the torch. Oxygen costs three cents a foot, and acetylene approximately one cent. Fifteen feet of oxygen is used to ten of oxygen when using a certain blow-pipe. Roughly, the mixture is two to one. So that a layman can easily figure

out how much oxygen he should use. He gets 450 ft. of gas from every 100-lb. drum of carbide, costing \$3.75. The

Charging the Generator.

The acetylene generator operates automatically. When the operator ceases

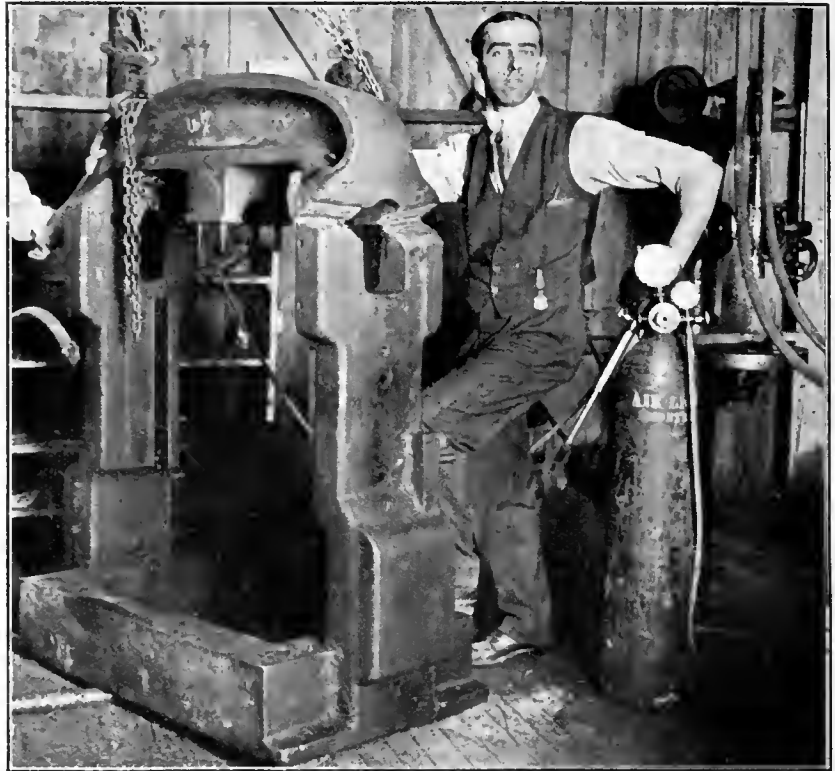

FIG. 4. SAVING THE FRAME OF A 1-TON BLISS PRESS.

Siche Gas Co. use one drum per week, and they are using the torch continuously.

to use his torch, the float closes the check valve, and no more gas is generated. Should the supply of carbide run out while work is proceeding, the dome can be refilled without any risk. When the plug is removed from the top of the dome the check valve closes, preventing the escape of gas. The water in the tank should be renewed, and the apparatus cleaned out once a week.

The Siche Gas Co. make this apparatus in various sizes, from 12 lb. to 250 lb. The small ones are suitable for blacksmiths and small repair shops. The firm have a 50-lb. portable outfit, which they use for repair work in Toronto. The same apparatus may be ordered to supply gas for lighting purposes at the same time as for welding.

It usually takes a month or more for a man to be moderately expert with the blow pipe. Operators are scarce, and for the man who is willing to branch out on a new line there is excellent opportunity as a welder. Men are so scarce, it is the intention of The Siche Gas Co. shortly to erect an adjunct to their plant in which to teach beginners. This method of obtaining recruits is already practised in the United States.

Requirements of a Welder.

The operator must have a fair knowledge of the expansion and contraction of metals. Blacksmiths and iron workers are suitable men, and learn quickly.

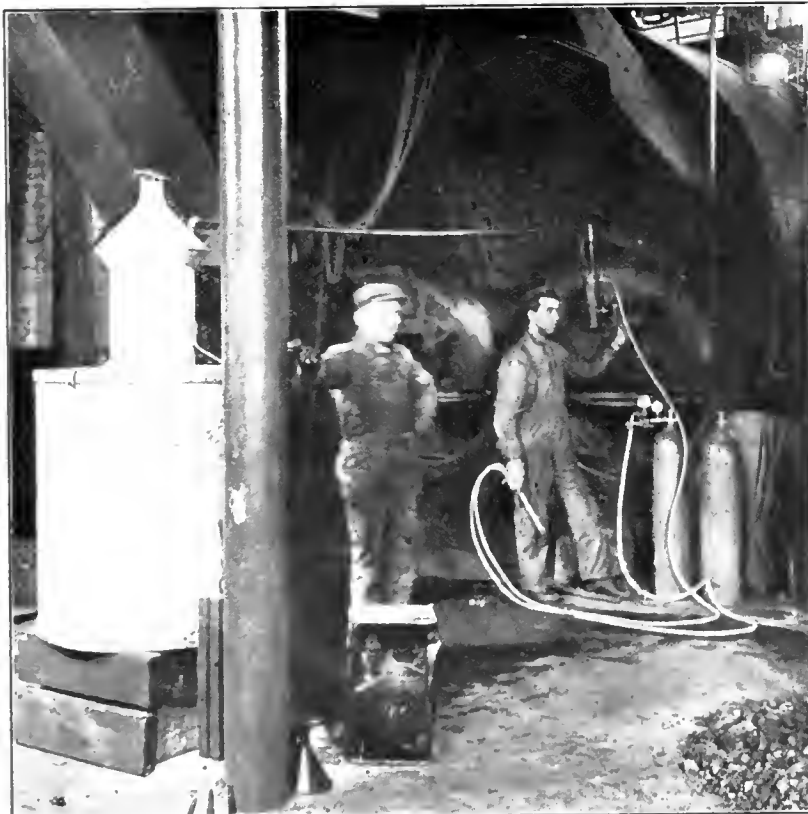

FIG. 3. PREPARING TO REPAIR A BOILER FRACTURE.

Smoked goggles are worn to shield the eyes from the fierce light of the acetylene, and asbestos mitts and apron. These are supplied with the outfit. The principal thing to learn is to save oxygen and acetylene by carefully pre-heating the work and cooking it slowly after welding. The latter operation is effected by packing the work in asbestos tanks.

The beauty of this process is that metal can be built on to a piece of work. On the welding table at The Siche Gas Co.'s works was a steel joint which had become worn out and loose. To duplicate this piece would have cost the owners a considerable sum; instead, they sent it to The Siche Gas Co., who added a steel coating to the worn-out parts,

An Example in Welding.

Take a case of welding: Suppose a piece of cast iron or steel shaft has fractured straight across. The welder would chamfer out the metal to the bottom of the fracture, and then clamp the parts together. He would first pre-heat the work. He would do this by means of two big torches in a brick oven built around the work. City gas with air is used as a fuel. The operation takes about an hour. When the work has reached a dull red heat, the welding torch is applied, and the welding stick melted into the fracture. The process of pre-heating is repeated several times until the work is completed.

A glance at the work being done in the Siche plant showed what a many-

or feet broken can quickly be made whole.

The Oxyweld process is adapted to work done in iron and steel foundries, manufacturing plants, locomotive repair shops, railroad car shops, shipyards, machine shops, boiler shops, contractors' repair shops, steel construction work, smelters and mining plants, automobile repair shops, aluminum foundries, etc.

Cutting With a Torch.

Now we come to another phase of the process which is more remarkable, if not so useful as that of welding; reference is made to Oxyweld cutting. When the Quebec bridge fell in August, 1907, ten thousand tons of steel were carried



OPERATOR INSIDE THE BOILER, FILLING THE FRACTURE.

after which it would be machined, and be as good as new. Although the oxy-acetylene process takes work away from the machinist in one way, it provides him with work in another.

In this case the operator stood over the table with torch in hand directing the hot cone of the flame near to the work. In his other hand he held a piece of Swedish steel, which melted in the 6,300 degrees of heat, the molecules of the one flowing with those of the other. A man who can flow solder smoothly can operate the Oxyweld pipe just as easily as he does the soldering iron.

sided industry this is. There was a big cast iron gear, which had had two new teeth inserted; several motor car cylinders and aluminum gear cases, the former having been cracked by frost, and the latter fractured by rough usage. The work of repairing cracks in engine cylinders is probably the most tedious encountered by Oxyweld operators.

There were also sewing machine frames, a brass automobile bracket, bicycle forks, and castings of every description. Boilers' seams can be made by this method instead of being riveted, thus making practically a seamless boiler. Expensive machines with lugs

down in a tangled mass of bent and twisted members. The oxy-acetylene cutter was found invaluable by the contractors in cutting the mass of steel into lengths convenient for handling. In that way the wreck was cleared up expeditiously.

Cutting a 6in. Shaft in 6 Minutes.

A piece of work done by The Siche Gas Co. recently in the Toronto Electric Light Co.'s power house will illustrate the use of the flame as a cutter. Two long wheel rooms required to be dismantled hurriedly, and the only way this could be done was to cut through

the 6-inch steel shafts every 45 inches. The shafts ran along two narrow chambers in the basement; and because of the situation of the arches, the work would necessarily be cramped. To go through the shaft with a back saw would have been a tedious process. Instead the oxy-acetylene flame was put to work. The average time for each cut through the 6-inch shaft was six minutes. Twenty cuts were made. Fig. 2 shows this work in operation.

The cutting process is as follows: First, the oxy-acetylene flame is turned on for a few moments until the shaft commences to redden immediately opposite the point of the flame. Then a fine stream of pure oxygen is turned on, and quickly the steel oxidizes, and is burned. The width of the cut is less than $\frac{1}{8}$ inch.

Repairing a Boiler.

Fig. 3 illustrates a difficult piece of work done by The Siehe Gas Co. for The Consumers' Gas Co., Toronto. A fracture had formed over the fire box in one of the watertube boilers and was leaking. In the ordinary course of events it would have been necessary to drill holes, rivet a plate over the defect, and make it watertight. By the Oxy-weld method a man was let down among the tubes, where he chamfered out the fracture, which was 13 inches long. Welding was done in about three hours. The boiler was tested the next day and the result pronounced satisfactory.

Fig. 4 shows a 1-ton Bliss press which had been fractured at the point shown, $3\frac{1}{4}$ inches deep and 16 inches across. The repair took about 14 hours to make, and cost approximately \$50. Thus an expensive piece of machinery was saved. This was done for The Office Specialty Co. of Toronto.

New Users of the Process.

The Siehe Gas Co. are just filling an order for the R. Weddell Dredging Co., of Trenton, Ont., who are installing a large stationary and portable plant for cutting and welding in their foundry and machine shops.

The Toronto Power Co. operate a portable cutting outfit, which they use for work on their power line between here and Niagara Falls.

The London Ornamental Iron Works are using a Siehe plant for welding ornamental grills, instead of bolting and riveting.

For small jobs in a confined space it is convenient to use the compressed acetylene torch, the largest of which holds 70 ft. of gas. It is also made in 10 and 15 ft. capacities. These are made by the Prest-O-Lite Co., St. Catharines, Ont. These are very handy for small, quick work.

L. R. Arnett is manager of The Siehe Gas Co.

C. N. R. IN THE ROCKIES.

A GAP of less than sixty miles separates the construction gangs on the Canadian Northern working north from Kamloops and from Yellow Head Pass, according to D. J. McDonald, the right of way agent. Mr. McDonald recently returned from an inspection trip along the route from the summit of the Rockies to Albreda Summit, the latter separating the Fraser River valley from the headwaters of the North Thompson River. Camps are strung along the route all the way from Yellow Head Pass to Albreda summit, over 2,500 men being on the payrolls of the various sub-contractors.

Track laying along the North Thompson north from Kamloops is in progress. Five miles of track have been laid and the grade finished to a point fifty miles beyond that. It is hoped that the uncompleted gap of sixty miles to Albreda summit will be finished by August or September.

Hundreds of cars of steel rails and other material have been received at Kamloops, and additional shipments are arriving daily. The company's yards there will comprise about ten miles of trackage.

CAR FERRY FOR THE ST. LAWRENCE.

THE National Transcontinental Railway officials have just placed an order with Cammel, Laird & Co., Birkenhead, England, for a combined steam car ferry and ice breaker. This will be used for transporting the Grand Trunk Pacific trains across the St. Lawrence pending the completion of the new Quebec bridge.

DOUBLE TRACKING ON THE C. P. R.

CONTRACTS for the double-tracking of 165 miles of C. P. R. lines, of which 135 miles form part of the Lake Superior Division, and 30 miles are situated in the Ontario Division, immediately west of Toronto, have just been awarded. The contracts cover the grading, bridge and culvert work, and steel laying, and the total cost of the work will be about \$5,000,000. The various contracts and the successful tenderers are as follows:—Lake Superior Division, Cartier sub-division, 29 miles, Cook Construction Co., of Sudbury; Chappleau sub-division, 13 miles, Dominion Construction Co., of Toronto; White River sub-division, 33 miles, Dominion Construction Co.; Schrieber sub-division, 13 miles, Dominion Construction Co.; Schrieber sub-division, 22 miles, Chambers, McQuaig, McCaffrey & Cochrane; Nipigon sub-division, 25

miles, Dominion Construction Co. Ontario Division—London sub-division, 30 miles, from Guelph Junction east to Islington, Jones & Girouard, Ottawa.

ROLLING STOCK OUTPUT.

VEHICLES turned out to the order of the C. P. R. during the week ended March 6 numbered 265, of which 84 were for replacement purposes and the remainder additions to capital account. The Angus shops supplied six second class cars, a diner, two tourist cars and one locomotive, while various firms were between them responsible for 172 box cars and 83 automobile cars.

MAKING CANS FOR SALMON.

IN a majority of thirty-three salmon canneries on the Fraser River, in British Columbia, preparations are well under way for the big run. Machinery is being overhauled, new machinery installed where necessary, lines of machines which have been idle for four years replaced, and old docks and wharves rebuilt. Contracts have been made with the Chinese for manning the canneries, and the boss Chinamen are now assembling their men. Can making machines will soon begin to chug and rattle, and bins will soon begin to fill up with tins ready for requisitions from the cannery floor later in the season.

Fifty-two lines of machines are in place in these canneries, with a season capacity of a million cases, at present prices worth a dozen million dollars. And there are packers and fishermen who expect this year's run to be as big as that of twelve and sixteen years ago, when the million mark was touched.

The Canadian Canning Company is making a departure this year in determining to pack its product in a vacuum tin, or sanitary can. This can is capped without solder, the cover being held in place by atmospheric pressure. After capping the covers are crimped down by a machine.

There are great advantages in the use of this can, it is claimed, though special machinery must be installed for it. These tins have long been in use in fruit canneries in the East, but this year will be the first time they have been used in the salmon canneries.

Mr. D. E. Parker, general manager of the Main Belting Co., has just returned to Montreal from a business trip to the Maritime Provinces, where he found business conditions excellent.

MACHINE SHOP METHODS ^A_N^D DEVICES

Unique Ways of Doing Things in the Machine Shop. Readers' Opinions Concerning Shop Practice. Data for Machinists. Contributions paid for.

FILING FIXTURES.

By F. H. M.

ON most machines there are fewer or many shafts requiring collars to prevent them from sliding into bearings. As these collars usually have a set screw in them which bears on the shaft, as shown by Fig. 1, it becomes necessary to flat off a place on the shaft as a bearing for the end of the screw, otherwise, when the latter is tightened, a burr will be raised on the shaft and be the cause of considerable trouble when it is desired to remove the shaft. Some makers mill this flat.

A good and simple filing fixture to do the work just as well, besides saving the time of an expensive machine, is shown held between vise jaws, Fig. 2. This consists of a hardened steel block split at the top, with a hole bored through it for the shaft, and a slot (A) at right angles to the hole. This slot is made deep enough to permit flattening the shaft and wide enough to guide some standard file, usually about 2in. wide. Below the shaft is drilled a 7-16in. hole, which holds a rod, having attached to one end a stop that acts as a gauge.

When using this fixture the workman slips it over the shaft until the end of the shaft comes against the stop. The shaft and fixture are then put into the vise, as shown, and the flat filed, making

sists of a taper wedge and a block to be used as follows: With the taper wedge back out of the way, the head of the screw is dropped into the hole (A) and slid along under the slot. By pushing the taper wedge into place and rapping with the file, the screw is effectively locked in position, and permits of filing

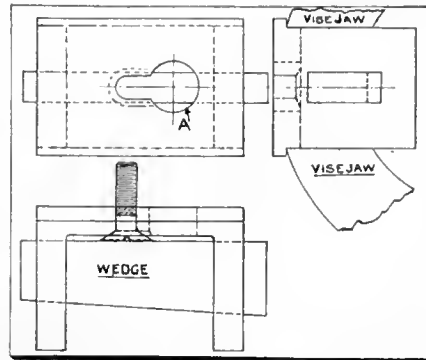

FIG. 3. FILING FIXTURES.

the end. A rap on the small end of the wedge is all that is required to loosen it.



THE CANADA GRIP NUT CO., LTD.

THE Canada Grip Nut Co., Ltd., have recently built an up-to-date factory at St. John's, Que., where they are now turning out daily 75,000 lock nuts of the type herewith illustrated. This ca-

rolled steel stock. Each bar of steel has an arch rolled lengthways along its centre line. After the blanks have been cut from the bar the centres are punched out, the nuts being then tumbled to remove all burrs. They are next tapped from .007 to .022 inch over size, according to the size of the nut. Pressure is then applied upon the top of the arch by automatic machinery, thus slightly deflecting the threads and reducing their diameter in the direction of the arch, as shown in an exaggerated form in the cut. The deflection is greatest on the top thread and diminishes towards the bottom thread. Each nut is gauged to determine its thickness, so that the deflection is absolutely uniform at all times.

It will be seen that the deflection will cause the nut to grip the top side of the bolt threads along the line of the arch, while at right angles to this line the

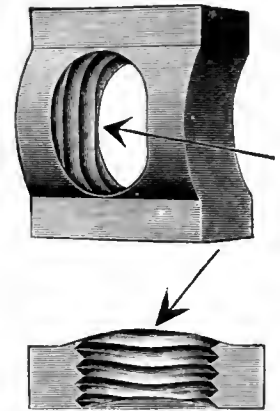

THIS CUT SHOWS AN EXAGGERATED CURVE IN THREAD PITCH—OR MORE THAN IS GIVEN IN PRACTICE, IN ORDER TO EMPHASIZE THIS FEATURE.

nut grips the bottom sides of the thread. In this way the grip nut is positively self-locking and need not necessarily be in contact with the main nut.

The nut is easily started on the bolt, since the bottom thread is not a complete one, owing to the arch. After being started, it is tightened up with a wrench in the usual way. It will lock upon a bolt as soon as all the threads are engaged and is guaranteed not to injure the bolt threads.

The plant at St. John's, Que., consists of a commodious factory for the manufacture of the nuts, and a machine shop where the tools, dies, etc., are made. About 70 men are employed and good business is reported from the leading Canadian railroads since the company commenced operations. The nuts are automatically handled between depart-

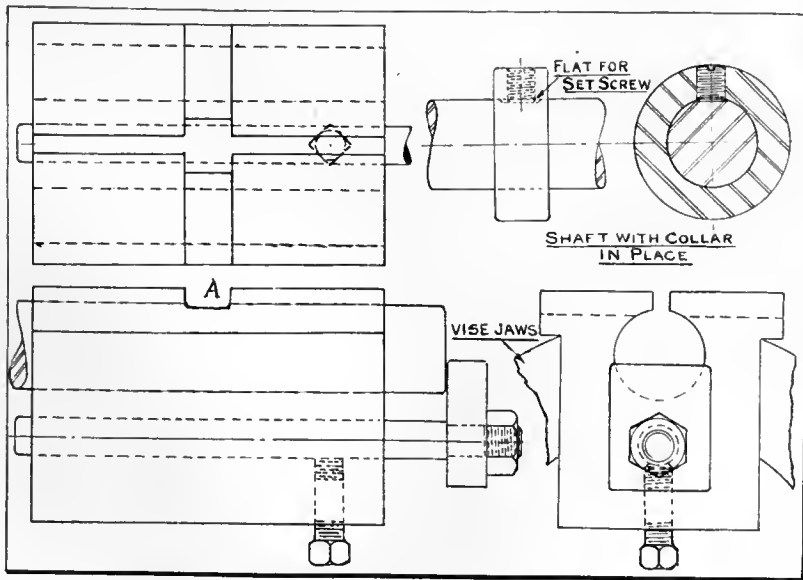

FIGS. 1. AND 2. FILING FIXTURES.

a very effective method of doing a simple hand operation.

Another filing fixture for the end of screws is shown by fig. 3. This con-

capacity will shortly be increased to 100,000 nuts per day. These grip nuts are made either square or hexagonal, being punched or sheared from special cold

ments and weighed on automatic scales. These, together with other labor saving devices, combine to make a factory that is thoroughly up-to-date in every way.

The head office of the company is in the Bank of Ottawa Building, St. James Street, Montreal.



A SPECIAL POLISHING MACHINE.

By L. E. Gehman.

THERE is here illustrated and described a special polishing machine used by a manufacturer of small intricate machinery, and designed to meet exacting requirements which none of the machines on the market would fill. Special features are the improved spindle bearings and a swinging idler pulley for adjustment of belt tension.

The bed (A) of the machine is bolted to a base casting (B), and to the bed are fastened brackets (C) in which are supported trunnion screws (D). The bearing boxes (E) are supported by these trunnion screws, and when the spindle is deflected in a curve due to the pull of the belt, the spindle bears along the whole length of the bearings (F), which are of cast iron. The means employed for the exclusion of dust from the bearings consist of the cast iron dust rings or flanges (G), which are screwed to the ends of the bearing boxes, while the oil, fed through oil cups screwed into holes (H) is filtered through felt rings (I) placed in bearings (F). The spindle pulley (J) is shrunk on to the spindle

and is protected by guard (K). The belt which drives the machine is housed inside the base and is driven by a pulley under the floor, thus the dust and dirt incident to overhead drive is eliminated.

To provide a quick way of starting and stopping the spindle, a swinging idler pulley (L) is provided; it also serves to keep the belt always at the right tension, for if the belt be too tight on such high speed machinery, it acts very detrimentally on the bearings. The idler pulley is carried in yoke (M) fastened to shaft (N). The position of the pulley is adjusted by the swinging arm (O), to which is fastened spring catch (P). This, when the pulley is at the position shown at (Q), out of engagement with the belt, catches on the pin (R), and when the pulley is in normal position of contact with the belt, the latch engages with a pin placed in one of a number of holes in the segment (S), depending on the tension it is desired to give the belt.

An adjustable electric light standard (T) is fastened to the floor near the machine and to a bracket (U) on the base. This has a lamp at each end of the horizontal bar, near the end of the spindle.



Kester Barr, has resigned his position with Manning, Maxwell & Moore, Inc., of New York, to take the position of manager of The Lumen Bearing Co., West Toronto, succeeding Mr. Fred Ganderton, resigned.

STEEL TOWN CALLED OJIBWAY.

THE bill to incorporate the Town of Pontiac, the "Steel City," planned by the United States Steel Corporation on the banks of the Detroit River, near Sandwich, Ont., was reported by the Private Bills Committee last week in the Ontario Legislature, the name being changed to Ojibway. A number of the members were suspicious. Several voiced the view that some protection should be provided for the workmen and those who purchased land.

In introducing the bill, Mr. Anderson, South Essex, claimed that in only one particular did it depart from the provisions of the Municipal Act—namely, in providing for "a dry town in perpetuity."

Mr. Wallace Nesbitt, K.C., representing the company, stated that it would be some years before the necessary buildings were ready for occupancy. Consequently there would be no considerable population for several years, and provision was made for a council to hold office until December 31st, 1916. In time the population would probably reach 20,000.

Hon. W. J. Hanna, Provincial Secretary, assured the committee that the Bill had been thoroughly considered, and that he thought there was no objection to it being reported.

Some objection had been taken to the name Pontiac on the ground that there were several other places with the same name. The change to Ojibway met with no opposition.

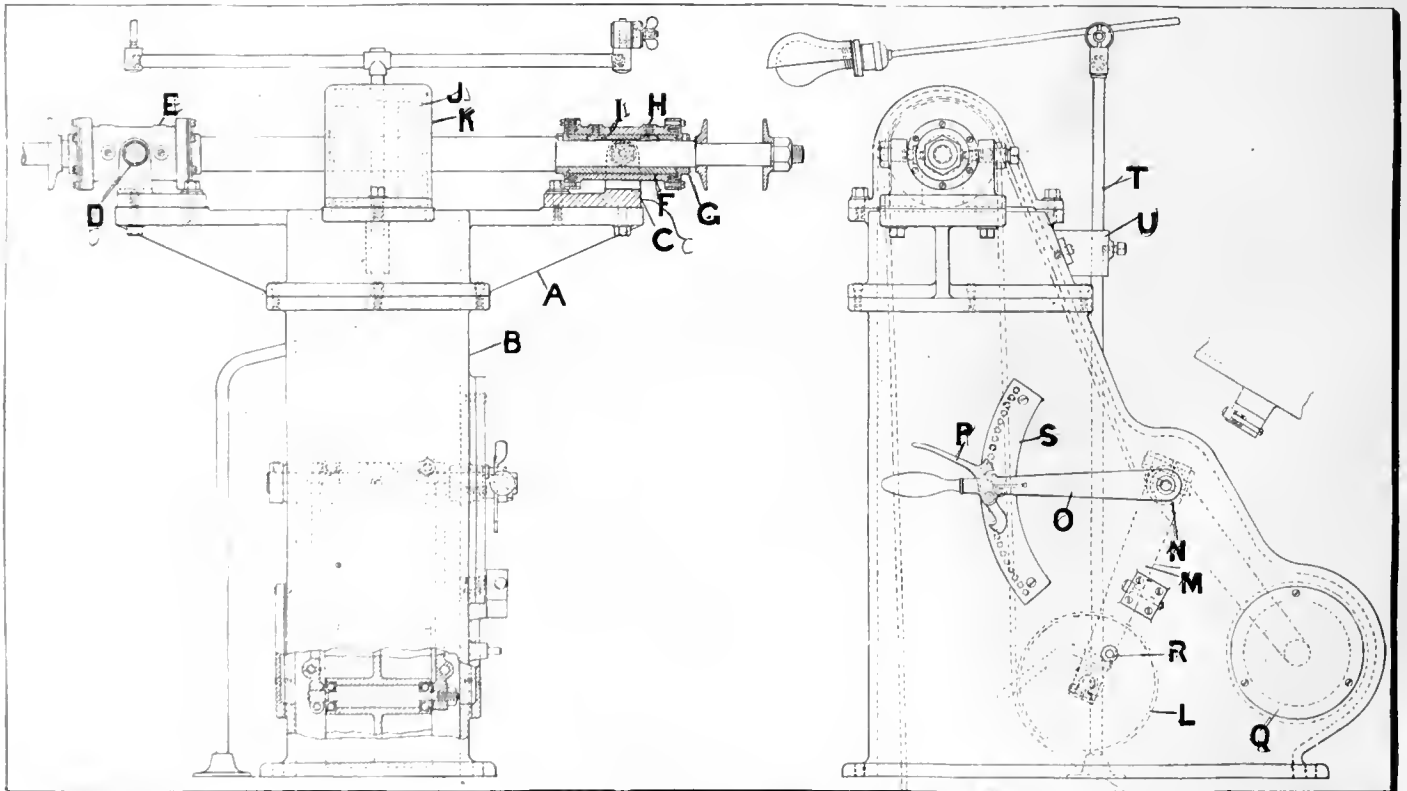

A SPECIAL POLISHING MACHINE.

MAY, JONES & CO., OF TORONTO, MANUFACTURE IN QUEBEC.

WHEN the Imperial Parliament passed the British North America Act in 1867, Canada was in its infancy, and the idea of its becoming a big manufacturing country, with enormous concerns stretching their tentacles into every nook and corner of the Dominion, was not given much consideration by the legislators. To-day it becomes the duty of the Supreme Court to define exactly what was intended by the Imperial Parliament when it conferred incorporating powers on the Provincial Legislatures. Thus we have what is known as the Companies Case, recently heard at Ottawa.

The fact that certain questions have been referred by the Governor-General in Council to the Supreme Court shows that at present nobody knows what powers are possessed by a company incorporated at Ottawa, or at Toronto, say. The questions asked are many, varied and vital. This will be easily seen when it is considered that a company incorporated at Toronto is ignorant of whether it can legally extend its plant across the border into Quebec; whether it can contract business in that province, and the nature of the business. The situation becomes worse when the Government itself is ignorant of these matters as well. The proceedings of the court at Ottawa as reported in the newspapers were so involved, it was difficult for a busy man to follow what was going on.

The first question put amounted to something like this. The British Parliament in 1867 gave the Province of Ontario power to incorporate companies 'with Provincial objects.' Take the Jones and Smith Machine Co., for example. Under their charter, are their operations limited to Ontario or not? There is a limitation conveyed in these words 'with Provincial objects.' Did the Imperial Parliament mean Jones and Smith only to manufacture machines in Ontario?

The second question asks whether Jones and Smith may sell their goods in Montreal, say, or in Vancouver, and if so, how may they do this? May they send their travelers out after orders, or may they sell their machines through an agency? The third and fourth questions relate to the status of insurance companies, and do not interest manufacturers much, yet it will be seen how vitally this situation affects the operations of such companies.

The fifth question is most important, and requires a clear answer. Can the powers of the Jones and Smith Co. be enlarged by the Dominion Parliament, or by say the Quebec Legislature? In other words, can the Jones and Smith Machine Co. by applying to Ottawa or

Quebec, or Victoria, or Fredericton, be given power to make machines at Sherbrooke, New Westminster, or St. John?

We will leave the Jones and Smith Machine Co. for a minute, and suppose that the Green Foundry Co. is incorporated at Ottawa. The next question the Supreme Court is asked is, whether the Ontario Government can prohibit the Green Foundry Co. from manufacturing their product at Welland say, without first having obtained a license to do so from the province, also, whether fees are required for this license.

Furthermore, can the Ontario Government limit the trading powers of the Green Foundry Co. in that province, and is this company to be governed by the same restrictions as govern the Jones and Smith Machine Co. for instance? The Supreme Court is asked to state what other restrictions can be placed on the Green Foundry Co. by Provincial Legislatures, and in what respect.

These, then, were the problems placed before the Supreme Court judges on February 24, and argument proceeded for several days. The Dominion Government, the Legislatures of Ontario, Quebec, Nova Scotia, New Brunswick, Manitoba, Alberta, Saskatchewan, Prince Edward Island, and the Canadian Manufacturers Association, were all represented by the most brilliant lawyers in the country.

Some idea of the situation can be gathered from the arguments made at the hearing. Mr. Justice Idington expressed the opinion that the Act might be interpreted to mean that Provincial companies might do anything necessary in the execution of its business purposes; that the Act did not contemplate the enormous activities of corporate bodies in the commercial world.

On the other hand, Mr. Justice Davies said it was inconceivable that Parliament could make the shareholders of a company responsible for a much wider sphere of liabilities than they had contracted to be responsible for.

It was pointed out to the Court by the Hon. A. W. Atwater, K.C., representing the Dominion, that the Imperial Parliament had used the word 'purposes' synonymously with the word 'objects' in reference to the 'Provincial objects' of a company. In the light of that, he considered that the Act could mean nothing else than that the Provinces were exclusively authorized to make laws relating to the incorporation of companies with purely Provincial powers. In reply to the Chief Justice, he said that while a lumber company might buy machinery in another province, that was a distinction as compared with the company's cutting logs there.

"If a company incorporated in Ontario sent travelers around throughout the rest of the country to take orders for which delivery would be made, would that be carrying on business outside the province?" asked Chief Justice Fitzpatrick.

"No, unless an independent agency were established outside the province, I should say," said Mr. Atwater.

Chief Justice Fitzpatrick then instanced the case of the E. B. Eddy Company, situated in Hull. Could it come across the river and build mills in Ontario?

"No," said Mr. Atwater.

"Could it buy pulp wood or pulp in Ontario, or contract an obligation to purchase it?"

"Yes," was Mr. Atwater's reply.

"If there was a glut in the Quebec markets, could the company sell the whole or any part of its products outside?" asked Mr. Justice Anglin.

"Yes, they could sell outside if they did not establish a separate agency outside. They could not, however, carry on any part of their manufacturing process."

"The provinces do not contend that Quebec province can say to the Eddy Company, 'You can carry on business in Ontario and Quebec,'" said the Chief Justice, "that would be ultra vires. They do not say that, having created the Eddy Company without restriction, that corporation can by reason of its existence go beyond the province and carry on a general lumber business."

During the hearing, the question was raised by the court why the Dominion Government had not exercised its power to veto Provincial legislation of an inimical character. The Hon. Wallace Nesbitt, K.C., representing the province of Ontario, said that he had been told by a very high authority that the unwillingness to provoke conflict was the reason why these questions had been submitted to the Court instead of the Dominion taking action.

In concluding the case, Mr. Newcombe, representing the Dominion, stated that anarchy and confusion, would follow the interpretation which the provinces wished to place on the words 'Provincial objects.' He read to the court various samples of Provincial legislation which restricted the operation of Dominion corporations, and which he said was not within the power of the provinces.

Mr. Newcombe admitted to Mr. Justice Duff that the practical question was, whether a company incorporated in one province could take advantage of legislation in other provinces to extend their operations.

The answers to these questions may not be given for several months.

The MacLean Pub. Co., Ltd.

(ESTABLISHED 1888.)

JOHN BAYNE MACLEAN - - - - - President
H. T. HUNTER - - - - - General Manager
PUBLISHERS OF

CANADIAN MACHINERY AND MANUFACTURING NEWS

A weekly newspaper devoted to machinery and manufacturing interests, mechanical and electrical trades, the foundry, technical progress, construction and improvement.

H. V. TYRRELL - - - - - Business Manager

EDITORIAL STAFF:

PETER BAIN, M.E., J. H. WILLIAMS, C. W. BYERS

OFFICES:

CANADA	GREAT BRITAIN
Montreal, Rooms 701-702 Eastern Townships Bank Bldg.	London, 88 Fleet Street, E.C. Phone Central 12960 E. J. Dodd
Toronto, 142-149 University Ave., Phone Malu 7324	UNITED STATES
Winnipeg, 34 Royal Bank Bldg., Phone Garry 2313	New York, R. B. Huestis, 115 Broadway, New York, N. Y., Phone 2209 Rector
Vancouver, H. Hodgson, 2640 Third Ave. West.	Chicago, A. H. Byrne Room 607, Marquette Bldg. 140 S. Dearborn St., Chicago
CABLE ADDRESS:	
Macpubco, Toronto.	Atabek, London, Eng.

SUBSCRIPTION RATE:

Canada, \$2.00; United States, \$2.50; Great Britain, Australia and other colonies, 8s. 6d. per year; other countries, \$3.00. Advertising rates on request.

Subscribers who are not receiving their paper regularly will confer a favor on us by letting us know. We should be notified at once of any change in address, giving both old and new.

Vol. IX. MARCH 20, 1913 No. 9

PRINCIPAL CONTENTS.

Developments in Machine Shop Practice During a Decade.....	281-287
General	287
Recent Judicial Decisions....What a Fire Chief AdvisesRailway Traffic in Nova Scotia.	
The Relationship Between Eyestrain and Illumination	288-290
General	290
Quebec Minerals....Every Brass Founder Should Know.	
The Determination of a Man's Natural Aptitude	291
General	291-292
Powerful Automobile Tractor....The Hudson Bay Port Project....Agricultural Machinery in Russia.	
The Close Relationship Between Friction and Lubrication.....	293-294
General	294
Coal Mining in Nova Scotia....Efficiency in Labor.	
On Welding and Cutting by the Oxy-Acetylene Process....	295-298
General	298
C.N.R. in the Rockies....Car Ferry for the St. Lawrence....Double Tracking on the C.P.R....Rolling Stock Output....Making Cans for Salmon.	
Machine Shop Methods and Devices	299-300
Filing Fixtures....The Canada Grip Nut Co....A Special Polishing Machine Steel Town Called Ojibway.	
May, Jones & Co., of Toronto, Manufacture in Quebec.....	301
Editorial	302
Industrial and Construction News	303-305
The General Market Tendencies	306-307
General	307
C.N.R. Plant at Port Mann....The Cost of Water Experts....New Incorporations.	
Selected Market Quotations	308-310
General	310
Gift to Engineer....The Montreal Drydocks and Ship Repairing Co....Massey-Harris Development.	

EMPLOYERS' DUTY TO APPRENTICES.

PREVIOUS to the days of our big trusts and corporations, ves. and previous to the days of the more modestly proportioned limited liability companies, there was a prolonged period during which the budding me-

chanic was taken by the hand, as it were, and carefully instructed in the intricacies of his chosen craft. Employers in those days kept in very close touch with lads serving their apprenticeship, and even should there have been a certain degree of self interest more or less apparent in their motive, it cannot be denied that the apprentice in nine cases out of ten reaped a substantial and life-long benefit. The changed conditions of proprietorship, consequent on the introduction of companies, corporations and trusts, contributed either by neglect or intent to, if not the abolition of apprenticeship, at least the elimination of that thoughtfulness for the welfare, and foresight concerning the benefits to be derived from the nurture of each rising generation of mechanics. A re-action on this score was, however, bound to follow, sooner or later, and a return to former conditions, or at least a rejuvenation of those of intrinsic value, became more and more palpably evident.

This reaction is in progress, we believe, and while its name may have changed, and many or fewer adaptations of the original elements of its constitution may now be in existence, the fact remains that the purpose and intent is as of old—the thorough training of the boy-man as a master of his craft. The watchword in the commercial and manufacturing world to-day, is that of efficiency, and the difficulty of securing this efficiency, may be largely attributable to our having to apply the principles underlying it to a more or less unimpressionable, although in other respects, worthy and conscientious operative staff. Our large corporations are becoming aware that the conservation of what prosperity they now possess, and its continuance, together with further achievement, depend not altogether on those who are “in the ring,” but on those entering and on those who will enter. The men responsible for the administration and management of our business and enterprises realize that a judicious selection of our youth, will provide, by careful cultivation, a harvest of talent, varied, it may be, in departmental fitness, but abundant in quality to perform efficiently the work of the particular sphere to which each individual bias seems best fitted.

Every man has, we believe, a particular niche which he can fill more advantageously than another, and if the proper pains are taken, and the proper attention be given to this feature, there will be fewer misfits and naturally fewer misfortunes. As we have said, interest in the boys employed in our workshops and factories, by those who rule, is more than anything else the “A to Z” of the matter. It has been urged that time and money spent on the propagation of sturdy and intelligent apprentices, is liable to develop into a more or less indeterminable loss, to the firm practising such a system, because of the certain fact that the most apt and capable of those trained will be snatched away by business competitors. The contention has, of course, some foundation of fact about it, at the same time no undue hardship will result, because of the conditions being, that of equal and mutual application as regards the transfer of an employe's affections.

All firms owe it to the lad not only to give him justice, but to give him opportunity to become a capable exponent of his trade—a master workman, and they owe it to themselves as a contributory to the efficient production of a quality and quantity output. The problems facing efficiency engineers will also be more rapidly and effectively disposed of if they devote more attention to the works and technical training of the coming generation, than by too vigorously assaulting the almost impregnable, because unimpressionable natures of those on whom long years of routine in a groove has left its indelible mark.

INDUSTRIAL ^A_N^D CONSTRUCTION NEWS

Establishment or Enlargement of Factories, Mills, Power Plants, Etc.; Construction of Railways, Bridges, Etc.; Municipal Undertakings; Mining News.

Engineering

Preston, Ont.—The Anchor Mfg. Co., Ltd., are building a new plant here. It will include a machine shop.

Montreal, Que.—A fire did \$75,000 damage on March 11 to Miller Bros. & Toms' machinery plant. The loss is covered by insurance.

Toronto, Ont.—Factory and warehouse, to cost \$100,000 will be built on Simcoe Street, for the Northern Electric & Manufacturing Co., Ltd.

St. Thomas.—The Michigan Central Railway will expend \$150,000 during the summer, erecting a new machine shop and a power house. Plans are now being prepared.

East Burnaby, B.C.—New machinery for the manufacture of cans will be purchased by the American Can Co. The capacity of their plant here will be trebled.

Bridgeburg, Ont.—The Tuttle & Bailey Mfg. Co., makers of steel registers, etc., will erect a plant here, costing \$60,000. It will be of concrete, measuring 200x100 feet, employing 40 hands. Headquarters are in New York. Mr. Gordon is stationed at Bridgeburg.

London, Ont.—Plans are ready for a foundry to be built at a cost of \$100,000 for E. Leonard & Sons. It will be a two-storey building, equipped with hydraulic machinery.

Niagara Falls, Ont.—The Huntley and Invincible, milling machinery manufacturers, of Silver Creek, will probably erect a factory here. The town has offered them a site.

Niagara Falls, Ont.—The Oneida Community are enlarging their plant, adding a big machine shop and storerooms. The plans for these are just complete. The firm manufactures game traps and silverware.

Vancouver, B.C.—The Columbia Block & Tool Co. will soon begin the erection of a machine shop and general building. Estimated cost, \$35,000. T. H. Bamforth, Pender West, Vancouver, is the architect.

Montreal, Que.—The two-storey brick pattern shop of Miller Bros. & Sons, situated at 120 Dalhousie Street, Montreal, was entirely destroyed by fire on March 12. The loss is covered by insurance. The machine shop immediately adjoining the pattern shop, and divided therefrom only by a wooden partition, was untouched. Work has already com-

menced on the rebuilding of the pattern shop.

Stratford, Ont.—A large cupola is to be erected in the foundry department of the New Hamburg Manufacturing Co.'s works shortly. The company have lately embarked in the manufacture of a new line of goods, which necessitates the addition of a new cupola to turn out the work.

Port Robinson, Ont.—The factory of the Standard Steel Construction Co. is completed, with the exception of an addition for a transformer house. Already part of the machinery has been installed and manufacturing commenced. The company is receiving orders for its goods and prospects are bright.

Medicine Hat, Alta.—The Great West Iron, Wood & Chemical works, of Prince Albert, evidently a subsidiary company of the C.N.R., has decided to locate a million dollar steel plant here for the manufacture of car wheels, structural iron and steel. It will employ from 300 to 600 hands. An agreement has been signed with the city whereby the city gives a sixty-acre site, a gas well and guarantees a quarter million of the company's six per cent. bonds. As soon as the by-law is passed, the company

CANADIAN CAR & FOUNDRY CO. EQUIPMENT REQUIRED

The Canadian Car and Foundry Co., Ltd., have issued specifications for the supply of the following machine tool equipment for the frog and track shop at their new Fort William plant:—

One 30 in. x 30 in. x 14 ft. frog and switch planer, direct driven by variable speed motor.

One 48 in. x 48 in. x 16 ft. planer for general work, direct driven by variable speed motor.

Multiple spindle gang drills for frog and rail work. Capacity 1½ inch drills. To have not less than three spindles.

One double punch and shear. 36-in. throat, 21-in. gap. Capacity to cut 1½-in. plate.

Two 2-spindle drills, having universal heads, with 4 feet lateral

travel to suit table about 24 in. wide.

One large and one small motor-driven rail bender.

Two 24-inch motor driven cold saws.

Multiple cold saws for cutting stock rails. Required with three heads. To be motor driven.

One 48-inch draw stroke shaper for general track work.

One diamond drill, for drilling holes in frogs, diamonds, etc. Capacity 1½-inch holes.

Engine lathes, 18 in. x 6 ft., and 20 in. x 6 ft.

48-inch radial drills, 2-in. capacity.

Portable pneumatic riveters, 20 tons capacity, 18 in. throat, 10 in. gap.

Portable and stationary rivet furnaces.

One plain milling machine, 10-in. centres.

One vertical drill press. Capacity, 2-in. holes.

One sensitive drill. Capacity ¾-inch holes.

One 24-inch power hack saw.

One 15-inch plain slotter.

One hollow spindle turret lathe, to take 1¼-inch stock.

Floor grinders.

Tool grinder for lathe and planer tools.

One 1¾-in. plain screwing machine.

Tenders to be addressed to the company's head office, Transportation Building, Montreal.

will start construction. N. Franks has put up a \$10,000 check as evidence of good faith.

The Smart Turner Machine Co., Hamilton, Ont., have recently booked the following orders:—Leek & Co., Vancouver, B.C., two centrifugal pumps; Inksetter Myers, Ltd., Hamilton, Ont., one centrifugal pump; the Vera Chemical Co., Burlington, Ont., one duplex pump; the Canadian Porcelain Co., Hamilton, Ont., one centrifugal pump; the Canadian Quarry Co., Ltd., Hamilton, Ont., one duplex pump.

Electrical

Melfort, Sask.—Contracts have been let for the building of a new power house.

Kingston, Ont.—The manager of the city's power plant expects to cut the price to 1.20 cents per k.w. hour.

Welland, Ont.—The Welland Electric Co. are taking contracts for 3 and 5-year terms at a low flat rate, to compete with the Hydro-Electric system.

Stratford, Ont.—The plant of the Electric Meter and Stamping Co., of New Hamburg, of which Mr. John Messner, is the head, was slightly damaged by fire last Monday.

St. George, N.B.—Plans are being prepared for 3 concrete dams to develop electricity for St. George Hydro-Electric Co. Cost, \$1,500,000. President, Percy W. Thompson, St. John, N.B.

Toronto, Ont.—The Buffalo & Fort Erie Ferry and Railway Co. are seeking power to electrify their line from Fort Erie to Buffalo. They will spend \$300,000, including \$50,000 on two ferry boats, and \$75,000 on a third.

Hamilton, Ont.—The city council passed a by-law on March 10, providing for the election next January of two members of the board to manage, with the mayor, the Hydro-Electric power plant, each member to receive \$1,000 salary.

Nelson, B.C.—The Waneta Development Co. will spend \$75,000 on its proposed power plant on the Salmon and Pend Oneille rivers. The initial power developed will be 200 h.p. A power line will be constructed to Sheep Creek and possibly to Salem. David Wilmsley, of Nelson, is a director.

Municipal

Kingston, Ont.—The city must erect a \$60,000 coal gas plant in order to supply dollar gas. A site is being sought on the waterfront.

Edmonton, Alta.—A street cleaning plant to cost \$58,400 is contemplated by the city council. Mayor, Mr. Short.

Swift Current, Sask.—The town will spend \$10,000 in acquiring land on which to build a fire hall. I. E. Argue, Mayor.

Kerrobert, Sask.—The town will spend \$65,000 on waterworks, \$12,000 on fire hall and apparatus, and \$5,000 on public improvements and rink.

Ottawa, Ont.—The city has applied to Parliament for power to convey water from the Gatineau Lakes to supply the cities of Ottawa and Hull. Que.

Prince Albert, Sask.—The Justice Grain and Measure Co., of Virden, Man., have approached the city council with a proposition to establish a factory for the manufacture of grain bags.

Stratford, Ont.—The ratepayers have passed by-laws authorizing the town to make concessions to the Farquharson-Gifford Co. and the B. F. Kastner Co., who will erect factories.

Windsor, Ont.—Engineer Brian favors a 25-ton incinerator plant at an estimated cost of \$25,000. Walkerville will be invited to help. London recently installed one costing \$39,700.

Vancouver, B.C.—A commission, with members from Vancouver, Burnaby, South Vancouver and Point Grey, will spend a million dollars this year on trunk sewers in these districts.

Vancouver, B.C.—The Canadian Mineral Rubber Co. have been awarded a contract to have a road connecting Vancouver and New Westminster at a cost of \$334,000.

London, Ont.—The city will spend \$110,000 on a power plant at Springbank Park, additional equipment for the electric light plant; for meters and other apparatus, and for the erection of new workshops. S. Baker, clerk.

St. John, N.B.—Miles Agar, commissioner, has been authorized to purchase two large steam rollers, a smaller motor roller, portable stone crusher, motor truck and hot mixer for bituminous concrete, plant to cost \$16,000.

Moose Jaw, Sask.—On March 6, by-laws totalling half a million dollars were voted on and passed: for parks and boulevards, \$10,000; new fire sub-station, \$30,000; extension of fire alarm and new apparatus, \$75,000; electric light and power extensions, \$185,000; water works extensions, \$150,000; schools, \$16,500; road improvements, \$30,000. Another half million will be asked this week for civic improvements.

General Industrial

Peterboro', Ont.—An extension to their spinning plant to cost \$12,000 will be erected for Bonner, Worth Co., Ltd.

Montreal, Que.—Smart Woods, Ltd. have acquired the business and property of the Montreal Tent & Awning Co.

Montreal, Que.—A soap factory is being built at Ville La Salle by the N. K. Fairbanks Co., costing approximately \$80,000.

Montreal, Que.—The Asbestos Corporation of Canada, Ltd., will purchase new machinery for their several plants. W. G. Ross, president.

Toronto, Ont.—An addition to their factory will be built for the American Watch Case Co., 511 King Street west. Architect, G. W. Gouinlock.

Sarnia, Ont.—A pipe line will be run from Lima oil fields near Cleveland, Ohio, by The Standard Oil Co., to supply the Imperial Works with crude oil.

St. John, N.B.—Fire damaged the plant of the corn meal mill of J. J. Manes, last week, to the extent of \$5,000. Maxim Schuster is their representative.

Melfort, Sask.—Rochrig & Koen Machinery Co., Edmonton, will build a brick making plant here if the city will sell gravel deposits at a reasonable price.

Lethbridge, Alta.—Albert and Jesse Knowlden will erect a brick plant with a capacity of about 3,000,000 a year. Most of their equipment has been purchased.

Toronto, Ont.—A biscuit factory to cost \$60,000, will be built on Sterling Road, for Telfer Bros., Ltd., Collingwood, Ont. Architects, Chadwick & Beckett, 20 Toronto Street.

Davidson, Sask.—The Davidson Clay and Product Co. will erect a \$35,000 plant, equipped with repressing machine and other machinery, employing 25 or 30 men. F. C. Whitelock is interested.

Montreal, Que.—An addition and extension to their dye works to cost \$30,000, will be made for the Dominion Textile Co. General contractors are the Bishop Construction Co., 904 E. T. Bank Building, Montreal.

Peterborough, Ont.—The buildings and plant of the Canadian Cordage Co., which recently went into liquidation, have been acquired by the Bank of Ottawa, which is now negotiating for an industry to occupy the buildings at an early date.

Stratford, Ont.—The Stratford Mill Building Co., Ltd., which suffered loss by

fire recently, have asked the city to guarantee \$30,000 and fixed assessment of \$12,000 for 10 years if they erect a plant employing 50 hands, worth \$60,000.

St. Thomas, Ont.—Thomas Bros., manufacturers of brooms and brushes, plan the erection of a three-storey factory, 120x50 feet, estimated to cost \$30,000. It will be of white brick construction, stone and concrete foundation, with felt and gravel roof.

St. John, N.B.—The Cornwall & York Cotton Mills Co. will erect two additional buildings, one an extension to the main factory, 22x60 feet, and the other a warehouse, 60x80 feet. Some of the present equipment will be displaced by machinery to manufacture a new line of goods, and additional machinery will also be installed.

Toronto, Ont.—The Eastern Rubber Co., which was recently organized to manufacture automobile tires, etc., has secured a site of four acres, and two manufacturing buildings will be erected. One of the buildings will be three storeys high, about 250x72 feet, while the other will be one-storey, about 200x72 feet. In addition to these, there will be suitable warehouses and a power plant.

Stratford, Ont.—The by-law authorizing the guaranteeing of bonds of \$10,000 for the B. F. Kastner Co., was passed. In consideration of this the company, which will manufacture mitts, gloves, fur overcoats, agrees to erect a factory building 80 feet by 40 feet, four storeys high, or the equivalent in such dimensions, and to equip the same with plant and machinery. The sum to be expended in erecting and equipping said factory to be \$15,000.

Thorold, Ont.—The Canadian Division of the Beaver Co., Buffalo, manufacturers of Beaver board fibre, etc., have purchased a 24-acre site at Beaver Dam, Thorold, Ont., on which it will erect a plant to cost between \$300,000 and \$400,000. The company will use Niagara Falls power, and have closed a contract for its first unit of 2,800 h.p. expecting to use eventually 6,000 h.p. It will also generate 500 h.p. in the boilers used for the treatment of fibre pulp, etc.

Railways—Bridges

Quebec, Que.—Work on the Quebec & Saguenay Railway will be finished this summer.

Toronto, Ont.—The railway committee of the Ontario Legislature have passed the city of Stratford Railway Bill.

Lethbridge, Alta.—The C.P.R. and the city will each bear half the cost of con-

structing a subway on 13th Street. The cost will be \$75,000.

Winnipeg, Man.—Plans have been prepared for a pontoon bridge connecting River Park with Windsor Park, to be replaced shortly by a permanent bridge.

Montreal, Que.—The city will build a subway under St. Hubert Street if the C.P.R. and the Tramways Co. will pay their share. The undertaking will cost \$250,000.

Toronto, Ont.—The Metropolitan Railway will extend their system through Markham Township, touching the villages of Unionville, Markham and Stouffville.

Vancouver, B.C.—A gap of less than sixty miles separate the construction gangs on the Canadian Northern working north from Kamloops and from Yellow Head Pass.

Winnipeg, Man.—Six bridges will be constructed for the C. N. Railway on Western Division. General contractors, The Manitoba Bridge & Iron Works, Logan Avenue west, Winnipeg.

Meductic, N.B.—A railway bridge for St. John and Quebec R. R. Co., Woodstock, N.B., will be built. President, A. R. Gould, Presque Isle, Maine, Engineer-in-charge, Ross Thompson, Fredericton, N. B.

Calgary, Alta.—The \$1,000,000 expenditure for ornate concrete bridges authorized by vote recently was checked, the bylaw being quashed by the supreme court. One bridge over the Bow river was to have cost \$600,000.

Brantford, Ont.—The right-of-way for the Lake Erie & Northern Railway between Paris and Galt is being bought. The contract for building the line has gone to Johnson Bros., of Port Hope; P. H. Secord & Sons, of Brantford, will do the masonry work.

Campbellford, Ont.—The Dickson Bridge Works Co. have completed the erection of a bridge consisting of two 50-foot spans over Deer River, near Cordova. Last week this firm secured the contract for a six-span bridge over the Mississippi River at Carleton Place.

Port Mann, B.C.—Two steamers loaded with 13,350 tons of steel rails for the Canadian Northern Railway are now on their way to Port Mann from Cape Breton. These are in addition to the Strathstay, which is expected up the river during the next few days.

Montreal, Que.—Contracts for the double-tracking of 165 miles of C.P.R. lines, of which 135 miles form part of the Lake Superior division, and 30 miles

are situated on the Ontario division immediately west of Toronto, have just been awarded. The contracts cover the grading, bridge and culvert work, and steel laying, and the total cost of the work will be about \$5,000,000.

Water-Works

Mimico, Ont.—The town is contemplating the purchase of a waterworks system.

Wallaceburg, Ont.—The town has engaged an expert to report on a new waterworks system.

Hull, Que.—A waterworks will be constructed at a cost of \$50,000. Engineer-in-charge, J. A. Laforest, C.E.

Lethbridge, Alta.—The city will purchase booster pumps, watermains, and will erect a water tower to increase the pressure. A filtration plant will also be built.

Calgary, Alta.—The Calgary Power Co. will develop another water power at Kananaskis Falls, spending \$1,000,000 on the project. The new plant will be ready next January.

Tenders

New Westminster, B.C.—Tenders for the erection of a municipal gas plant were withdrawn by the Northern Construction Co. at the council meeting last week.

Toronto, Ont.—Tenders will be received by the Chairman of the Board of Control up to April 1st for trolley wire, cable, suspensions, hangers, pull-overs, sleeves, ears, frogs, bolts, bands, etc. H. C. Hoeken, Mayor.

Windsor, Ont.—Tenders will be received until March 25th for: One generator for incandescence lighting for a 260 h.p. engine. 100 to 125 ornamental cast iron poles, 13 ft. 6 in. high, 5 light cluster (1 upright and 4 pendant) 6-in. standard globe holders; suitable for underground wiring system. Tenders for poles and generator to be separate. Stephen Lusted, Clerk.

Port Arthur, Ont.—Tenders will be received up to March 31, for the supply of the following Railway Material to be delivered f.o.b. cars Port Arthur, via boat and rail, before May 20th. Tender A—No. 2-0 round trolley wire, 8 tons. No. 4-0 flexible feeder wire, D.B.W.P., 6¾ tons. Tender B.—24,200 ft. 80-lb. 5-in. tee rails, 50,000 ft. 60-lb. 5-in. tee rails. 76,500 spikes, 5½ x 9-16. 840 pair angle bars, 60-lb. rail, 4 hole. 6-800 bolts, 3¾ x ¾ hex. nuts. 3,360 bolts, 4¾ x 7/8 hex. nuts. Tender C.—Steel Intersection, Frogs, Switches, etc. J. J. Hackney, Commissioner Utilities.

The General Market Conditions and Tendencies

This section sets forth the views and observations of men qualified to judge the outlook and with whom we are in close touch through provincial correspondents.

Montreal, Que., March 17.—Business in the machinery market continued good last week, though no specially large orders are reported. The Canadian Car and Foundry Co. are in the market for machine tool equipment for the frog and track shop at their new Fort William plant, now in course of erection. This order will probably run into \$60,000 or \$70,000.

The contracts for the Transeona car shops equipment have not yet been placed by the N.T.R., but the matter will probably be closed up during the next two weeks.

Some good orders for tool steel were received last week.

Pig Iron.

Good business in pig iron was reported last week, with practically no change in prices. One firm is quoting the following prices on Old Country pig for delivery at the opening of navigation:— Middlesboro, No. 3, or Clarence, No. 3, \$21.50. Carron, \$23.50. These prices look attractive at the present time.

Steel, Metals, Etc.

There is little to report. Business in all lines continued brisk. Steel angles advanced from \$2.50 to \$2.75, but there was no change in plain bars.

Copper was slightly weaker, but not enough so to affect prices. Tin continued to fall and is now being quoted at 49 cents per pound, as against 50½¢ a week ago.

Toronto, Ont. March 19.—A disturbing influence in the local machinery market has been the liquidation sale of the E. R. Thomas Motor Car Co., Buffalo, N.Y. At this, over a thousand machine tools were disposed of, and all the local dealers, and big manufacturing concerns sent representatives to the sale. This has held off trade from the larger concerns, though there seem to be plenty of small orders in, and several large ones. To a motorcycle concern which has just built a new plant in Brantford, Ont., A. R. Williams and Co. have sold a 24-inch shaper, three lathes, universal grinder, a Bliss press, a milling machine, two drills, a hacksaw, and a grinder. A number of American machine tool builders are advancing their prices, including nearly all the drill and lathe builders. A prominent Bridgeport and Cincinnati firm reports advances of from 5 to 10 per

cent. Advances are coming in every day. The reason given is that manufacturers are so far behind with orders, they are taking advantage of the situation to get more money, and, of course, the increased cost of material. The C.P.R. machine shop equipment will most likely be bought in Montreal next week. The National Cash Register shops, which are to be erected in Toronto as soon as the frost is out of the ground, should mean a big demand for machinery from Canadian agencies. Orders have been placed in Montreal by the Abitibi Pulp and Paper Co. for the big machinery to be used in their new Iroquois Falls plant, but it is understood that orders for pumps and like equipment have not yet been placed. Small sawmills are being bought by lumber men in Northern Ontario, as the short frost has prevented big machinery from being secured. Rather than wait for the opening of navigation, portable machinery is being bought.

Pig Iron.

A significant feature of the pig iron market this week is the drop in price of Drummond McCall & Co.'s product, which is now quoted at from \$19.50 to \$20.50—roughly, a drop of a dollar per ton. The result is a big sale to smaller firms all over the country, in lots of 100 tons or so. The general opinion is that a distinct fall in prices will take place soon. Big manufacturers are buying from hand to mouth, as it were. There are no changes in American prices. Inquiries are still being made from the Canadian side, but deliveries are still for the distant future. While movements on the stock market are ominous, the United States steel local representative says little notice is paid to this as the orders are coming in all right.

Plates, Tubes, Structural, Steel, Etc.

There will be no changes in steel prices for the next few months, is the opinion expressed by a local steel company representative. Inquiries are coming in as fast as ever for early deliveries. The trade is more optimistic. Manufacturers are placing more contracts than they did last month. In February they decided to wait until things looked better, and as nothing better has come, they are placing their specifications. This is true not so much of structural men as of manufacturers of window sashes, agricultural implements, baby carriages, etc. In the last few days, the prices of tubes have been raised from 2 inches upward.

Below this size, prices remain the same. The advance is due to difficulty in getting supplies and in replacing stocks.

Coke and Coal.

The coke and coal market is strong. The supply is short, owing to continued difficulty in getting cars across the frontier at Black Rock. This refers to coal particularly. Manufacturers who have been wise have kept a reserve stock on hand, which was accumulated when supplies were moving with more freedom. The outlook is bright, and people interested are of the belief that the demand will be greater than ever this year.

Metals.

There has been no sensational movement in the metal market this week. Prices are about the same. Aluminum is scarce. Copper is firmer if anything.

St. John, March 17, 1913.—One of the finest factory buildings in Eastern Canada, if not in the whole Dominion, is that which has recently been occupied by Messrs. Simms & Co., brush and broom manufacturers, in this city, for actual working purposes, and which has just been completed in construction and equipment. Not only from the point of view of construction is the building superior, but from other standpoints as well, for instance, as regards equipment, up-to-date appliances, facilities for effective handling of the work, and comfort and convenience for the employees. While in the old factory which they occupied in Union street, conditions were much better than in many other large concerns, the new plant easily outdoes the former in this respect.

The design of the building with all-glass walls makes it one of the most health preserving in the city, as there is a constant flood of sunshine. Heat is supplied by the vacuum system and the ventilation is as nearly perfect as possible. More than fifty wash basins have been placed at various points about the large works for the convenience of the employees, and each basin is supplied with both hot and cold water. Lockers are provided for each employee to keep his or her outdoor garments in while at work. Cosy lunch rooms have been provided for the workmen where they may eat their lunches, tables for four having been installed, and the company are now planning the serving of lunches at cost price, supplying the rooms required for the purpose, the light, heat and the help as well. The patrons of this lunch room instead of being seated at the long or round tables as are sometimes found in workshops, will be seated four at a table in sociable manner, and a very substantial luncheon will be served at the lowest possible price.

About three hundred hands are now employed in this factory, which is about double the number employed in the other one, within the last few years. It is expected that the number will soon be still further increased. The design of the structure was only decided upon after lengthy conferences by the company, so as to save needless labor and produce the maximum of results in turning out the finished product. The architects were Lockwood, Greene & Co., of Boston, and the builders the Aberthaw Construction Co., also of Boston.

The length of the factory is 300 feet by 50 feet in width, with four storeys and basement. The walls of the building are 80 per cent. of glass in order to furnish a great amount of light, and there are no less than 25,000 panes of glass used. On each floor of the factory the design is such that six feet of aisle extend from end to end, with machines on either side. An attractive appearance is presented on each floor through the mushroom construction, leaving the interior without girders. The only wooden floor in the factory is over 200 feet of the basement, and it is of mill construction with a hardwood top and resting on concrete girders. The object of this was to eliminate belts and the dust collecting system from the woodworking department overhead, and to make it possible to place the machines on that floor to the best advantage.

The factory has its own water supply. Its power house is constructed of hollow tile 69 by 46 feet. The dry kiln building is 62 by 52 feet and two storeys in height. There is also a lumber shed 100 by 56 feet, and 22 feet in height, with special facilities for handling the heavy hardwood lumber. In the main factory two elevators have been placed and there are also two stair towers, absolutely fireproof. There is a complete fire protection system with hydrants and hose houses in the grounds, and a 1,000 gallon fire pump besides a complete sprinkler system. The whole factory is nicely painted and finished in very attractive manner. Its erection has been a matter of pride to St. John citizens for it is recognized as one of the most up-to-date buildings of its kind in the Dominion.

C.N.R. PLANT AT PORT MANN.

THE contract for ten or fifteen stalls of the roundhouse at Port Mann, B.C., for the Canadian Northern Railway, will be let shortly, and work on the building started thereafter. As for the plans for the other buildings, it is stated that the Port Rouge shops at Winnipeg will be taken as a model for those to be erected at Port Mann.

The beginning of the area covered by the shops is just a mile distant from the depot to be erected. Plans for this depot are now out and it is understood to cost from \$16,000 to \$18,000 to erect. In addition to the station, the buildings for the future city service will consist of a freight shed near the depot, 40 by 200 feet, and one on the west end of the wharf of 300 or 400 feet in length.

There will be a coaling plant whose bunkers will be fed from a coal conveyor at the river. Boats will bring the supply of coal up the Fraser river from Vancouver Island in sufficient quantities to supply the road's requirements from this point to the Yellowhead.

The roundhouse and shops will be found in the flat portion of land in section 33 on the south side of the tracks. This concrete building will have but ten or fifteen stalls at present, but will ultimately be enlarged to accommodate 35 locomotives. Adjoining this will be a huge building 600 by 150 feet for locomotive repair work. For the present it will be fitted up to accommodate twenty-five engines undergoing repair at one time. Just beyond this building will be the foundry, 200 by 100 feet; the coal and iron shed, 200 by 50 feet; blacksmith shop, 200 by 100 feet; store and office building, 150 by 50 feet; all of these buildings running parallel to each other.

Farther on there will be located a shop for the repair and alteration of coaches, 200 by 100 feet; a planing mill, 200 by 100 feet; and a freight car shop 300 by 100 feet. All of the shops named above will be substantial buildings of concrete construction. The most remote buildings will be the lumber shed built of wood, 200 by 100 feet, together with a dry kiln, a pattern shop 50 by 50, and a power house 100 by 50 feet.

As it now seems likely that the Canadian Northern will not be ready to operate through trains until the latter part of 1914, there is no necessity for rushing the construction of the shops, excepting the roundhouse, so that the work on these will not be started until next fall.

Ultimately, there will be 70 miles of classifications, distributing and storage tracks at Port Mann, but for the present only 30 miles will be laid. Of this mileage about ten miles has been completed. For local use, 11 tracks will be constructed just behind the wharf.

THE COST OF WATER EXPERTS.

THE sum of \$15,798.41 represents the bill rendered to the city of Edmonton by Messrs. Francis, Ross and Lee, board of consulting engineers, who have reported on the Edmonton water supply. This does not include their report on

the electrical distribution system. The bill rendered is itemized as follows:

To professional services to date of the board of engineers of Edmonton, Messrs. Walter J. Francis, R.A. Ross and R. S. Lea, in connection with water supply and other problems, exclusive of electrical distribution systems.

June, 1912—To time of the board in connection with preliminary investigation of the water supply conferences with civic officials at Edmonton, discussions of matters pertaining to data and visits to various sources of supply at \$100 per day for each member of the board, \$3,550.

June 25, 1912, to Feb. 20, 1913—To time of the board subsequent to preliminary investigation, in connection with circulation water problems, tunnel problems, study and report regarding pump tenders, study and report regarding general water supply, at \$75 per day for each member of the board, \$7,086.25.

June, 1912, to date—To expenses paid for transportation, hotel accommodation, photography, telegrams and miscellaneous, \$748.66.

June, 1912, to date—To time of staffs engaged in detail work, draftsmen, clerks and stenographers, \$4,413.50.

New Incorporations

Dominion Fireless Cooker Co., Ltd., incorporated at Toronto, to manufacture cookers, capital \$40,000: Incorporators, H. Earle Wallace, Lowell Wallace Wood, Eric R. Thomson, J. A. Christilaw, and C. Gordon Lynch, of Toronto, Ont.

Ottawa Contractors, Ltd., incorporated at Ottawa, as contractors, capital \$250,000: Incorporators, W. H. Poupore, Chapleau, Que.; J. W. Hennessy, Fort Coulonge, Que.; W. H. Dwyer, J. Taylor, and J. Robinson Osborne, Ottawa, Ont.

Temagami Chief Mines, Ltd., incorporated at Toronto, to work and develop mines, capital \$2,500,000: Incorporators, John Ferguson, J. Melton Adam, S. Cameron Arrell, Eileen Jamison and E. E. Purvis, all of Toronto, Ont.

Brunelle Furnace & Boiler Co., incorporated at Ottawa, capital \$100,000, to manufacture boilers at Three Rivers, Que.: Incorporators, J. A. Jutras, Johnny Boivin, Wilfred Desceoteaux, J. B. Godbout, Three Rivers, Que.; A. Heroux, and Hercule Desceoteaux, of Yamachiche, Que.

McDonald Hydro-Electric Heating Co., Ltd., incorporated at Ottawa, to provide power plants, capital \$1,000,000: Incorporators, J. D. McDonald, R. Watson DeMorest, E. Hamilton Low, of Sudbury, Ont.; R. McConnell, J. Beaton Watson, W. Clark Perkins, and Angus W. Fraser, of Ottawa, Ont.

SELECTED MARKET QUOTATIONS

Being a record of prices current on raw and finished material entering into the manufacture of mechanical and general engineering products.

PIG IRON.

	Per Ton.	
Foundry No. 1 and 2, f.o.b., Midland	\$19 50	\$20 50
Gray Forge, Pittsburg		17 15
Lake Superior, charcoal, Chicago		18 00
	Mont'l. Tor'to.	
Canadian f'dry, No. 1..	\$22 00	\$22 50
Canadian f'dry, No. 2..	21 50	22 00
Middlesboro, No. 3....	23 50	23 50
Summerlee, No. 2	25 00	26 50
Carron, special	25 00
Carron, soft	25 00
Cleveland, No. 1	24 25	25 00
Clarence, No. 3	23 75	24 50
Jarrow		25 50
Glengarnock		26 00
Radnor, charecoal iron.	30 00	34 50
Ferro Nickel pig iron (Soo)		25 00

BILLETS.

	Per Gross Ton.	
Bessemer billets, Pittsburgh ...	\$29 00	
Open hearth billets, Pittsburgh.	30 00	
Forging billets, Pittsburgh.....	36 00	
Wire rods, Pittsburgh	30 00	

FINISHED IRON AND STEEL.

	Cents.	
Common bar iron, f.o.b., Toronto..	2.10	
Steel bars, f.o.b., Toronto.....	2.20	
Common bar iron, f.o.b., Montreal.	2.15	
Steel bars, f.o.b., Montreal.....	2.25	
Bessemer rails, heavy, at mill....	1.25	
Iron bars, Pittsburgh	1.70	
Steel bars, Pittsburg, future	1.45	
Tank plates, Pittsburgh, future....	1.50	
Tank plates, New York, future....	1.61	
Beams, Pittsburgh, future	1.50	
Angles, Pittsburgh, future	1.50	
Steel boops, Pittsburgh	1.60	
Toronto Warehouse f.o.b., Toronto.		
	Cents.	
Steel bars	2.30	
Small shapes	2.45	
Warehouse import, freight and duty to pay:		Cents
Steel bars	1.95	
Structural shapes	2.05	
Plates	2.15	
Freight, Pittsburgh to Toronto:		
18 cents carload; 21 cents less carload.		

BOILER PLATES.

	Mont'l. Tor'to.	
Plates, ¼ to ½-in., 100 lbs.	\$2.40	\$2.40
Heads, per 100 lbs.....	2.65	2.95
Tank plates, 3-16 in.	2.60	2.60
Tubes, per 100 ft., 1 inch	9.00	8.50
“ “ 1¼ in.	9.00	8.50
“ “ 1½ “	9.00	9.00
“ “ 1¾ “	9.00	9.00
“ “ 2 “	9.00	9.00
“ “ 2½ “	11.50	11.50
“ “ 3 “	12.00	12.00
“ “ 3¼ “	13.75	13.75
“ “ 3½ “	15.00	15.00
“ “ 4 “	18.50	18.50

BOLTS, NUTS AND SCREWS.

	Per cent.	
Stove bolts	80 & 7½	
Machine bolts, ¾ and less	65 & 5	
Machine bolts, 7-16.....	57½	
Blank bolts	57½	
Bolt ends	57½	
Machine screws, iron, brass	35 p c	
Nuts, square, all sizes.....	4c per lb off	
Nuts, Hexagon, all sizes..	4¼ per lb off	
Flat and round head.....	35 per cent.	
Fillister head	25 per cent.	
Iron rivets	60, 10, -0 off	
Wood screws, flathead, bright	85, 10, 7½ p c off	
Wood screws, flathead, brass	75, 10, 7½ p c off	
Wood screws, flathead bronze	70, 10, 7½ p c off	

WROUGHT IRON PIPE.

The following are Toronto jobbers' discounts on pipe. (Card weight) in effect from October 11th, 1912:

	Standard	Buttweld Black Gal.	Lapweld Black Gal.
¼ ⅜ in.	63	48
½ in.	68	58
¾ to 1½	72½	62½
2 in.	72½	62½	69½ 59½
2½ to 4 in. ..	72½	62½	71½ 61½
4½ to 6 in.	72	62
7, 8, 10 in.	66½	54½

X Strong P. E.

¼, ⅜, ½ in. ..	64	54
¾ to 2 in.	68	58
2½ to 3 in. ...	68	58
3½ to 4 in.	65	55
4½ to 6 in.	63½	56½
7 to 8 in.	56½	46½

XX Strong P. E.

½ to 2 in.	43	33
2½ to 4 in.	43	33

WROUGHT IRON PIPE.

The following are Montreal jobbers' discounts on pipe. (Card weight) in effect from October 11th, 1912:

	Standard	Buttweld Black Gal.	Lapweld Black Gal.
¼ ⅜ in.	64	49
½ in.	69	59
¾ to 1½	73½	63½
2 in.	73½	63½
2½ to 4 in. ...	73½	63½	72½ 62½
4½ to 6 in.	74	64
7, 8, 10 in.	70½	58½

X Strong P. E.

¼, ⅜	64	49
½ in.	65	55
¾ to 2 in. ...	69	59
2½ to 3 in. ..	69	59
3½ to 4 in.	66	56
4½ to 6 in.	65½	58½
7 to 8 in.	60½	50½

XX Strong P. E.

½ to 2 in. ...	44	34
2½ to 4 in.	44	34

IRON PIPE FITTINGS.

Canadian malleable, 40 per cent.; cast iron, 65; standard bushings, 70; headers, 60; flanged unions, 65; malleable bushings, 65; nipples, 75; malleable, lipped unions, 65.

COKE AND COAL.

Solvay Furnace Coke	\$5.25
Solvay Foundry Coke	6.50
Connellsville Furnace Coke	5.50
Connellsville Foundry Coke	6.00
Yough, Steam Lump Coal	3.83
Penn. Steam Lump Coal	3.63
Best Slack	2.95
All net ton f.o.b. Toronto.	

OLD MATERIAL.

	Tor'to.	Mont'l.
Copper, light	\$11 00	\$10 50
Copper, crucible	14 00	13 50
Copper, uncre'bled, heavy	12 00	12 00
Copper wire, uncre'bled..	12 00	12 00
No. 1 machine compos'n..	11 00	11 00
No. 1 comps'n turnings..	10 00	10 00
New brass clippings	9 00	9 00
No 1 brass turnings	7 50	7 50
Heavy lead	3 25	3 00
Tea lead	2 50	2 75
Serap zine	3 50	3 25
Dealers' purchasing prices.		

Have You a Buyer's Power ?

¶ Whether you are a Purchasing Agent or a Purchasing Proprietor a heavy load of double responsibility is yours every time you make a decision and sign an order.

¶ Can you discharge that responsibility with a brain charged with instantly available information?

¶ We can furnish an indexed brain to any buyer of machinery. We have been doing it for several years to some of the keenest and highest paid Purchasing Agents in Canada. This is how we do it:

¶ Half a dozen pages from the back of "Canadian Machinery" you will find a Buyers' Directory. This is arranged alphabetically according to the name of the machine. Below each item is given a list of the most reliable makers.

¶ If you want a Drill or a Lathe, a Milling Machine or a Motor, a Reamer or a Riveter, a Planer or a Punch, or any kind of machine or piece of equipment, all you have to do to bring the best makers to your desk is to consult the Buyers' Directory in "Canadian Machinery."

¶ Here is to be found a list of the most dependable manufacturers. It is a universal catalog of all your needs and a ready reference guide to good buying. It is an Honor Roll of Progressive Machinery Makers. It is a brain saver and a reputation builder for purchasing agents—a time saver and a money maker for men who do their own buying.

¶ Take a careful inventory of your present and possible requirements. Note what machines or supplies you will have to purchase in the near future. Consult Machinery's Buyers' Directory and write for the catalogs and the literature of the firms, who are in a position to supply you. Get loaded for emergencies. Fill up on information. Decide before you have to who can best meet your requirements.

¶ Perhaps the very machine or machines you will need are illustrated and described in this number of Machinery. Look up the Buyers' Directory and then the Advertisers' Index (just inside the back cover.) Better still, take a look through all the advertising pages and read as you run. It won't take you long and it will do you a whole lot of good.

¶ Let "Canadian Machinery" help you in your buying, and then tell others where you obtained the information.

The Present State of the Art of Industrial Management

The subject matter of this article has been abstracted from the "Majority Report" of the subcommittee on Administration appointed by the American Society of Mechanical Engineers, New York. In another section of this issue will be found the "Minority Report" in the contents of which, Mr. H. H. Vaughan, Assistant to Mr. J. M. Small, Vice President of the A. S. M. E., is the only subscriber. The observations made and conclusions arrived at in each case are worthy of careful study.

DURING the past few years a new way of thinking has been developed in the industrial management world. This new attitude toward work, the new organization characterizing the modern industrial plant:

(1) The industrial, scientific character of the subject which has led to a statement made within the International Commission on Scientific Research, in a report on the matter of industrial management: "Scientific work in industry has advanced far beyond the stage of the 'empirical' method, and the scientific character of industrial management is becoming more and more pronounced." The scientific character is shown by the great increase of technical education in the last decade and by the increasing number of scientific publications in the field of industrial management, particularly those dealing with the scientific character of industrial management.

(2) The scientific industrial character of the subject in the field of organization and industrial management in which there is a tendency toward the scientific character of industrial management, particularly those dealing with the scientific character of industrial management.

(3) The application of modern scientific methods to the study of industrial management, particularly those dealing with the scientific character of industrial management.

(4) The application of modern scientific methods to the study of industrial management, particularly those dealing with the scientific character of industrial management.

(5) The application of modern scientific methods to the study of industrial management, particularly those dealing with the scientific character of industrial management.

(6) The application of modern scientific methods to the study of industrial management, particularly those dealing with the scientific character of industrial management.

(7) The application of modern scientific methods to the study of industrial management, particularly those dealing with the scientific character of industrial management.

(8) The application of modern scientific methods to the study of industrial management, particularly those dealing with the scientific character of industrial management.

The Principles of Management

Industrial management is a science in the sense that it is a systematic study of the principles of management. It is a science in the sense that it is a systematic study of the principles of management.

Industrial management is a science in the sense that it is a systematic study of the principles of management. It is a science in the sense that it is a systematic study of the principles of management.

Industrial management is a science in the sense that it is a systematic study of the principles of management. It is a science in the sense that it is a systematic study of the principles of management.

Industrial management is a science in the sense that it is a systematic study of the principles of management. It is a science in the sense that it is a systematic study of the principles of management.

Industrial management is a science in the sense that it is a systematic study of the principles of management. It is a science in the sense that it is a systematic study of the principles of management.

Principles of Management of Work

An example of the application of the principles of management of work is shown in the following: The principles of management of work are shown in the following: The principles of management of work are shown in the following:

An example of the application of the principles of management of work is shown in the following: The principles of management of work are shown in the following: The principles of management of work are shown in the following:

Applying and Managing Organization

The idea of applying and managing organization is shown in the following: The principles of management of work are shown in the following: The principles of management of work are shown in the following:

chine, however, was the viewpoint. It was looked upon as the producing unit.

Combined and contrasted with this was a lack of knowledge of scientific principles and their sure application. Charles Babbage treats of this forcefully, as follows:—

“There is perhaps no trade or profession existing in which there is so much quackery, so much ignorance of the scientific principles, and of the history of their own art, with respect to its resources and extent, as is to be met with amongst mechanical projectors.”

In the same vein he emphasizes the need of accurate drawings as if having in mind the poor quality of the work from the average draftsman of his day: “It can never be too strongly impressed upon the minds of those who are devising new machines, says he, that to make the most perfect drawings of every part tends essentially both to success of the trial and to economy in arriving at the result.” He further points out that there is another important factor in successful industry in addition to machinery. We read that “in order to succeed in a manufacture, it is necessary not merely to possess good machinery, but that the domestic economy of the factory should be most carefully regulated.”

Domestic Economy of the Factory.

These quotations foreshadow modern methods of thinking out the work in advance and transferring this thought to the workmen. The subsequent development has had the effect of advancing still further the division of labor, and beginning the division of thought. The drafting room presents the first example of the trend, in its collection of engineering data, in its prediction of results and in the formation of staff organization, but from the period of the last quotation almost to the present there has been no change in the basic principles discovered and applied in industry. There has been nothing but an extension of those already known.

The place of greatest advance has been in the drawing room. The art of machine design has been greatly developed. The last half of the last century saw a tremendous increase in inventions, a tremendous furtherance of the application of transference of skill to machines and tools. The skeleton of an industrial organization of this period, one that was too large for a single executive to manage, consisted of a designing department and a production department, each with a head responsible to the manager. The first of these, the one that was the means of embodying skill in the machinery and tools of production, was highly developed and organized. Experiment, research and detailed study were constantly resorted

to, as aids in reaching the desired result. The work was highly specialized and the employees highly paid. Not infrequently the manager or chief executive devoted much of his own time to this part of the business.

The production department presented a contrasting condition. The workmen were given the tools and machines designed in the drawing room and by their own unaided skill were expected to produce work of the desired quality and quantity. Except in rare instances, no effort was made to transfer the skill of the management to the production department and the employees, or to undertake the division of executive thought. Very little consideration was given to the workmen as a producing unit.

Features of the Change.

Within the past 20 or 25 years certain changes have taken place in the attitude of many production managers toward the problems that they face and the forces and means that they control. An increasing amount of attention is being given to the worker. An early evidence was the development of profit-sharing, premium and bonus systems, to reward increased effort and output. There followed welfare work, industrial betterment movements, the adoption of safeguards and regulations to minimize industrial accidents, the substitution of the principle of accident compensation for employers' liability and an improvement in the physical surroundings and conditions of factories. All of these tendencies have been fostered and to a great extent initiated by employers, yet to-day they are by no means generally adopted.

Another tendency, less pronounced in character, has as its object the improvement of the personal relations between employee and employee and between employee and employer. It is an effort to establish the best of factory working conditions in those things not physical in nature, to develop and maintain a shop atmosphere free from all harassing and hindering influences. It is an attempt to make use of the results of experimental psychology, in improving working conditions.

Problems of Production.

The most important change, however, and one that comprehends the others, is in the mental attitude toward the problems of production. The tendency is toward an attitude of questioning, of research, of careful investigation of everything affecting the matters in hand, of seeking for exact knowledge and then shaping action on the discovered facts. It has developed the use of time study and motion study as instruments for investigation, the planning

department as an agency to put into practice the conclusions drawn from the results of research, and methods of wage payment which stimulate co-operation.

All of these changes have affected the production department much more than the designing department. The effect is to extend the principle of transference of skill to production, so that it completely embraces every activity in manufacture. The skill of the management is consciously transferred to all of the operations of the factory. This extension is expressed by these phrases:— The drawing room is the planning department of design, and the planning department is the drawing room of production.

Nature of the Committee's Investigation.

To obtain information on present conditions the committee wrote to recognized experts, to executives of plants in many lines of industry, to students of industrial problems, and had many interviews with men in these various fields. The response to requests was in the main most generous, and we are deeply indebted to the information thus received for a large portion of the following sections of this report.

Throughout the following pages there is a plentiful use of illustrative quotations, and many of these are taken from correspondence resulting from investigations. On some points diametrically opposed views have been expressed. In such cases we have presented both. In no case has credit been given for these views or quotations, as the information was solicited in confidence.

Differences of Opinion.

Requests for a definition of the new element in the art of management brought forth a difference of opinion as to its existence. The opposed view is given in the following quotations:—

“I am not aware that a new element in the art of management has been discovered. There have been no new discoveries in scientific management of industrial institutions. Common-sense men have used common-sense methods always. The term ‘scientific management’ is a catch-word which assumes that industrial institutions have not been scientifically managed—which is not the case. My experience and the experience of my friends has been that there has been no new element injected into the art of management. In the writer's opinion there is very little that is new about it. There is hardly any part of it that has not been practised by managers for the past 100 years. The trouble is there are not enough managers with sufficient initiative to set the system moving properly. The problem

presented is not the adoption of something entirely new; but rather the extension to every detail of our work of something which we have already tried."

Turning now to the other side of the question, from a large number of definitions of this new element we select the following as very nearly conveying, taken together, the complete conception as our investigation has disclosed it:

"The best designation of the new element I believe to be 'scientific management.' This term already has been adopted quite generally, and although frequently misused, carries with it the fundamental idea that the management of labor is a process requiring thorough analytical treatment and involving scientific as opposed to 'rule of thumb' methods."

"The writer ventures to define the new element briefly, but broadly, as:—The critical observation, accurate description, analysis and classification of all industrial and business phenomena of a recurring nature, including all forms of co-operative human effort and the systematic application of the resulting records to secure the most economical and efficient production and regulation of future phenomena."

"Stripped of technicalities the method of the modern efficiency engineer is simply this:—First, to analyze and study each piece of work before it is performed; second, to decide how it can be done with a minimum of wasted motion and energy; third, to instruct the workman so that he may do the work in the manner selected as most efficient."

"The Taylor system is not a method of pay, a specific ruling of account books, not the use of high-speed steel. It is simply an honest, intelligent effort to arrive at the absolute control in every department, to let tabulated and unimpeachable fact take the place of individual opinion; to develop 'team play' to its highest possibility."

"As we conceive it, scientific management consists in the conscious application of the laws inherent in the practice of successful managers and the laws of science in general. It has been called management engineering, which seems more fully to cover its general scope than a science."

These quotations convey the ideas of a conscious effort to ascertain and study facts and systematically to apply them in instructing the workmen and in controlling every department of industry. Setting these against the underlying principle of the transference of skill we conceive the prominent element in present-day industrial management to be: The mental attitude that consciously applies the transference of skill to all the activities of industry.

Labor-saving Management.

The expression "labor-saving management" better conveys the meaning of the movement. It has the further advantage of being easily and surely understood because of its strict analogy with the term "labor-saving machinery." It is no chance that puts these two terms labor-saving machinery and labor-saving management, in conjunction, for the first is the past development and the second the present trend of industry, and they will be closely and inevitably associated in the successful manufacturing of the future. Throughout the following pages of this report the terms "industrial management" and "labor-saving management" are used, the first to denote the subject broadly, the second the newer attitude.

Regulative Principles of Industrial Management.

The lack of accurate thinking and clear expression in regard to management are nowhere better shown than in many of the statements of the so-called principles. These can be divided into two classes—personal characteristics of managers and mechanical means of applying. It is evident that neither can show us the way in which the activities of industry are to be regulated.

In our investigation preparing for this report, one correspondent writes as follows:—

The regulative principles of management along scientific lines include four important elements:

(1) Planning of the processes and operations in detail by a special department organized for this purpose.

(2) Functional organization by which each man superintending the workman is responsible for a single line of effort. This is distinctly opposed to the older type of military organization, where every man in the management is given a combination of executive, legislative and judicial functions.

(3) Training the worker so as to require him to do each job in what has been found to be the best method of operation.

(4) Equable payment of the workers based on quantity and quality of output of each individual. This involves scientific analysis of each operation to determine the proper time that should be required for its accomplishment and also high payment for the worker who obtains the object sought.

Another correspondent finds the solution of problems of management in the observing and regulating of three classes of industrial phenomena:

(1) The economic results of different arrangements and forms of materials and operations upon them, either to produce equipment or product. This

covers the whole field of recorded experience from invention and design of product and tools down through the successive shop processes to ultimate finished product and its tests in service. It is the object of the scientific method to make the best of this experience, in its essential details, readily available for all concerned, and to see that it is actually absorbed and put in practice.

(2) The economic results of varying executive methods for effectively directing human efforts as a whole in the use of the above experience. This covers the entire field of building up, co-ordinating and controlling the supervising organization of a plant with its statistical and recording systems.

(3) The economic results of steps taken to raise the industrial efficiency of the individual worker in every grade of service. This covers the whole problem of labor reward, intensified ability, conserved energy and the general relations of employer and employee.

We have pointed out that the underlying principle, or cause in the widest sense, the application of which has built up modern industry, is the transference of skill. This basic principle is put into effect on the management side of all industrial activities, through three regulative principles which sum up the ideas in the above quotations. These have been concisely stated as:

(1) The systematic use of experience.

(2) The economic control of effort.

(3) The promotion of personal effectiveness.

The first includes the use, in all essential detail, of traditional knowledge, personal experience and the results of scientific study on the part of the executive force. It implies the accumulation and use of records and the setting up of standards.

The second includes the division and subsequent co-ordination of both executive and productive labor; the planning of single lines of effort, the setting of definite tasks and the comparison of results; and the effective training of the workers. It implies the previous acquisition of skill by the executives.

The third includes a definite allotment of responsibility and the adequate, stimulative encouragement and reward of both executive and productive labor; the development of contented workers, and the promotion of their physical and mental health. It implies the most thorough comprehension of the human being.

The Practice of Management.

As labor-saving management springs from a change in mental attitude, the beginning of its practice should be with the persons having the final responsibility, the proprietors of closely owned

businesses, the directors of larger establishments, or the officials having charge of government works. Before any changes are made, such men should clearly understand the viewpoint from which all of the managerial work is to be done, the principles that are to be applied, the general method of their application and the results expected.

A similar mental attitude must be fostered among all the members of the executive force and a period of training for them begun, which may include a redistribution of function and responsibility, and also a detailed study of production by scientific methods. This is the period of division of thought, training of the management staff and setting-up standards of performance, and before there can be effective transference of skill to the workers in the production departments, careful performance must be secured.

Conception of Modern Management.

The usual conception of modern management is that it affects the workmen most of all, tending to stimulate them to turn out increased production to their possible hurt. This is wrong. If the principles outlined are followed, the executive, or non-producing labor is the most affected. Its individuals are compelled to study, plan and direct. They must acquire knowledge and skill in order to transfer it. It is a system of management that forces the executives to manage. Being so, the introduction of modern management in a plant must be made slowly. The causes of most so-called failures are principally two:—A failure of the executives to acquire the vital mental attitude, and too great haste in application. The latter seems to be the dominant one. Each step of the work should be made permanent before the next is begun.

Showing of Production Records.

We have examined records of production which clearly show a lessening of individual output among workers who had been trained for some time and had achieved good results as soon as untrained workers were put with them, thus lessening their share of personal supervision. Later, the original standard of production was again reached, but the results seemed to be directly proportional to the amount of skilful supervision, during a lengthy period of training. When those who are to operate the new methods have acquired the necessary knowledge and established sufficient standards, the work of putting these into effect can be begun. This means the fixing of the best attainable working conditions and giving each worker definite tasks with an adequate reward to each one who attains to the standard set. This part of installing

the methods must be accomplished with tact and patience, remembering that leadership and example are powerful aids in bringing about enthusiastic co-operation. The training of the workers is essential in this part of the application, and must be far more than mere demonstration, the mere showing that a thing can be done. There must be patient teaching and help until the required degree of dexterity or skill is acquired, up to the habit stage. It is evident that such work cannot be hurried.

Elements of Permanence in Methods.

Such, broadly, are the three steps in the practice of management. It is now necessary to investigate the internal elements of permanence in such methods. If the proper mental attitude is once taken, we believe it will never be given up, and this is substantiated by a few cases when early attempts to improve management were failures and the methods abandoned. Later, however, other attempts were made with substantial success. The mental attitude outlived the failure. Thus, in a given industrial organization this feature would not be lost except by a loss of the executive staff. The permanence of records of performance and standards needs only to be mentioned to be appreciated. Once set up in an industry, disaster is invited if they are disregarded.

To these is added a third in the nature of a spur from the working forces to the managing force. An adequate reward is one of the essentials. Whatever disturbs the mechanism of production interferes with the earning of the rewards. The workers at once object, pointing out the trouble and insisting that it be rectified. The management is spurred to keep all conditions up to the fixed standard.

No Rigid and Inflexible Practice.

The practice is outlined, while built upon fixed standards and procedure, is by no means rigid and inflexible as has been alleged. The design and construction of labor-saving machinery is carried on with multiplicity of different details. Labor-saving management should likewise use a variety of details suited to the requirements of different industries and plants. There can be nothing fixed in such human endeavor except the underlying principle. As a simple matter of fact, we have found different methods, details and nomenclature in use in different plants. Many efforts have undergone marked changes and development since first installed. Further, this idea of rigidity is repudiated by some of the foremost management experts.

Management Experts.

The position of expert in the practice of management is more clearly seen as experience increases. The element of mystery has already departed, and this is to be welcomed for it means the downfall of mere "systematizers." One of the unfortunate features of the movement has been the rise of alleged experts who have been ready to promise extravagant results if they were allowed to systematize an industrial plant. The test which their work cannot meet is the one of permanence.

An industrial manager who has had signal success in directing large enterprises sums up the more undesirable characteristics of systematizing practice as follows:—

1. The publication and quotation of statistics regarding gains made through the use of particular systems, without a frank statement of the degree of inefficiency of the plants before reorganization.

2. The failure to view the plant from the investor's standpoint rather than as a laboratory offering opportunities for interesting and expensive experience.

3. The failure to admit that every application of past solutions to unstudied new and different conditions is an experiment.

4. The waste of time and money on problems that will yield to scientific treatment, but which do not recur often enough to justify such a solution.

5. The undervaluing of effective leadership in management and consequent lack of permanency in results.

6. The overvalue of emasculated 'system' leading to a curious non-responsibility on the part of any person for the total result.

7. The frequent assumption that the treatment of the problems of similar plants should be identical.

8. The failure to properly appraise in a growing concern the value of its internal asset of 'good will.'

9. The imperfect analysis and appreciation of the human factor in industry, with a consequent failure to reckon patiently with 'habit' and 'inertia' and a tendency to hasty 'substitutions,' bringing about the breaking up of valuable organization."

The real expert concentrates on the facts of a given problem, and from a wide experience in analysis, coordination and practical responsibility, works out a solution by scientific methods, suited to the material and human factors involved. The tendency for him is to do less of the detail work of installation, but to train and direct the persons who are permanently to manage. This is a true process of transference of skill.

Broad Results of Labor-Saving Management.

In cases where the use of labor-saving management can be considered a success the broad results have been:—A reduced cost of product; greater promptness in delivery with the ability to set and meet dates of shipment; a greater output per worker per day with increased wages; and an improvement in the contentment of the workers. This last item is shown by the fewness of strikes under the new management, and in the refusal of those working under the changed conditions to join in a strike of their fellows in the same plant, who were not working under the new methods. This last mentioned situation has arisen a number of times. In one case an attempt was made to strike a room where about one half of the operators were under the new conditions. These refused to go out; the rest went.

The results indicate certain advantages to both employer and employee, but it is charged that the movement has not yet entirely justified itself from the economic viewpoint, for it has not reduced the cost of product to the consumer. The implication is that its possibilities will not be realized until employers, employees and the public are alike benefited. With this view we are in most hearty accord. Labor-saving machinery has brought the comforts that we all enjoy to-day. Labor-saving management promises to extend these comforts. Where properly administered, it is conserving labor and is thus contributing to the good of society at large, and although the benefit to the consumer may not be generally felt, it has already developed to a certain extent and will continue to develop as the natural result of increased production.



NEW INVENTIONS.

MESSRS. Pigeon & Davis, the patent solicitors, of 71a St. James St., Montreal, report that 137 Canadian patents were issued for the week ending February 25th, 1913, of which 69 were granted to Americans, 32 to Canadians, 24 to residents of Great Britain and 12 to residents of other foreign countries.

Of the Canadians who received patents, 16 were residents of Ontario, 7 of Quebec, 4 of British Columbia, 2 of Nova Scotia, 2 of Alberta and 1 of Manitoba.

In the United States, for the same week, 699 patents were issued, 19 of which were granted to Canadian investors.

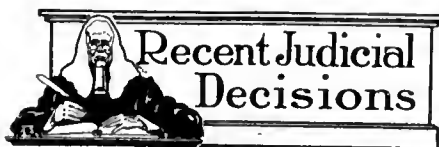

Vancouver, B.C.—The jury in the case of Seigis vs. Ocean Falls Co., Ltd., of Ocean Falls, awarded the plaintiff \$4,680, the full amount which could be recovered in this case under the Employers' Liability Act. S. S. Taylor, K.C., counsel for the defendant Company, moved for judgment, notwithstanding the verdict, and Mr. Justice Morrison, before whom the case was heard yesterday afternoon, reserved his decision on the motion. The amount of \$4,680 was awarded to Adam Seigis, a millwright, for the loss of a portion of his left hand while he was in the employ of the Ocean Mill Co. It was the contention of the plaintiff that while engaged in repairing some cog wheels in the sawmill, the carriage of the machinery was put in operation, placing him in a very dangerous position. A few minutes later a steel cable running past, struck him on the neck, causing Seigis to lose his balance and fall from the box on which he was standing while making the repairs. He threw out his left hand to save himself and the member was caught in the cogs and crushed. The defense contended that the foreman, Mr. John Blake, was told to start the mill by Seigis, and for that reason believed that the repairs had been finished. It was also asserted that the millwright was well aware of the perilous position he was in while at work. Action was also brought for \$27,000 damages under the Common Law, but this was dropped by the plaintiff's attorney.

Toronto, Ont.—Evidence was taken on March 11 at the inquest upon T. Rogolo, a Polish operative who became entangled with some shafting in the factory of the Ideal Bedding Company on March 4 and was fatally hurt. The fellow-employees of the unfortunate man told of seeing him first as he was whirled about the revolving shaft, and believed that he had endeavored to shift a belt while the machinery was in motion. Both the foreman and R. J. Underwood, the master mechanic of the factory testified that all employees were warned against this mode of procedure, and that it was prohibited. The latter examined the machine immediately after the mishap and found it in good condition.

Calgary, Alta.—The million dollars expenditure for ornate concrete bridges authorized by vote recently, received a check on March 6, when Mr. Justice Walsh, of the Supreme Court, handed down a decision quashing the by-law on proceedings instituted by J. D. Lapell. Members of the City Council say the

case will be appealed. One of the bridges was to have been a high level structure across the Bow River of elaborate design and costing \$600,000.

Hamilton, Ont.—The damage action of Copeland v. the National Steel Car Co., before Judge Snider, at the Sessions, had an unusual development. In the afternoon the jury visited the plant of the Company to inspect the machine which the plaintiff said injured him. J. Hart, the lawyer for the Company, when the case was called the next morning, objected to the jury on the ground that some of the jurors had taken part in a discussion with employees of the plant during the inspection, and he argued that they were unduly influenced, and not competent to act in the case. Judge Snider upheld this contention, and dismissed the jury. The case was traversed.

Sarnia, Ont.—The Appellate Division at Osgoode Hall, Toronto, has dismissed the appeal of the town of Sarnia from the decision of Mr. Justice Leitch, awarding \$1,200 damages for injuries sustained by Reginald Waller, the six-year-old son of a baggage man. The lad was walking on the street, and as he passed where some pavement repairs were in progress, the heavy ladle broke away from its handle and splashed molten asphalt over his face, covering his eye and filling his ear, so that his hearing has been impaired. At the trial, Mr. Justice Leitch held that the cauldron was a thing that would naturally attract a child, and arouse its curiosity, and that, therefore, special precautions should have been taken, as the molten asphalt was essentially dangerous.



MANGANESE STEEL DREDGE BUCKETS.

THE hard digging which the ladder dredge Corozal has been doing on rock in the Pacific entrance channel to the Panama Canal has caused severe wear on its buckets, and the lips, which make the cutting contact, are worn and jagged. The buckets have shown some weakness in the back, and an order has been placed with the Taylor-Wharton Iron and Steel Co., of High Bridge, New Jersey, for six buckets with body, lip, and bushings of manganese steel, ready for use; and six lips of manganese steel, for use interchangeably on the buckets. These are for experimental purposes, and if they should be superior to the present carbon steel buckets, the latter will be supplanted throughout. These buckets have a capacity of 35 cubic feet each, and as made of carbon steel, weigh 5,400 pounds. The dredge operates 39 of them on a chain.

Canadian Pacific Railway Co. Elevator, Port McNicholl, Ont.

The idea of establishing the Port McNicholl terminal with elevator accommodation, in addition to those existent at the head of Lake Superior, had, as its purpose, the storage and reloading of grain into railroad cars for transportation with greater efficiency, eastwards through Canadian territory. That the step taken was a wise one has been amply proven.

PORT McNicholl is situated at the extreme eastern end of the Georgian Bay, about 7 miles from Midland. Here an elevator of 2,000,000 bushels' capacity was completed early in 1911. After about a year's operation, it was clearly demonstrated that in order to

pleted in time to be filled with the 1911 crop before the close of lake navigation. It is 179 feet wide and 226 feet long, making the total length of the elevator 452 feet. There are altogether 64 cylindrical bins, each 32 feet 11 inches in diameter, and 62 interspace bins. The

with corrugated iron, the whole being mounted upon 40 heavy car wheels. Steel stairs run all the way from the bottom to the top, and the roof and floors are of concrete. Each of the towers has a capacity of 20,000 bushels per hour, and each one is self-propelling, traveling independently of the other on a double track between the storage house and the slip. The marine legs are designed so that they can enter passenger boats as well as freight boats, and a complete set of air operated shovels and clean up shovels is provided to bring the grain to the legs as rapidly as possible.

Grain is delivered to 1,000 bushels scales, after which it is taken to the top of the bins of the storage house or working house. The longitudinal conveyors which receive the grain from the marine towers run the entire length of the two units. Grain for shipment from the new portion is conveyed through the basement of the first storage to the car shipping house. In this car shipping house 200 cars can be loaded in 10 hours. Cars can also be unloaded in the working house and boats loaded by means of a special loading spout on one of the towers.

Power Equipment.

All the machinery is electrically driven, power being generated in a steam plant separate from the main building, and shown at the extreme

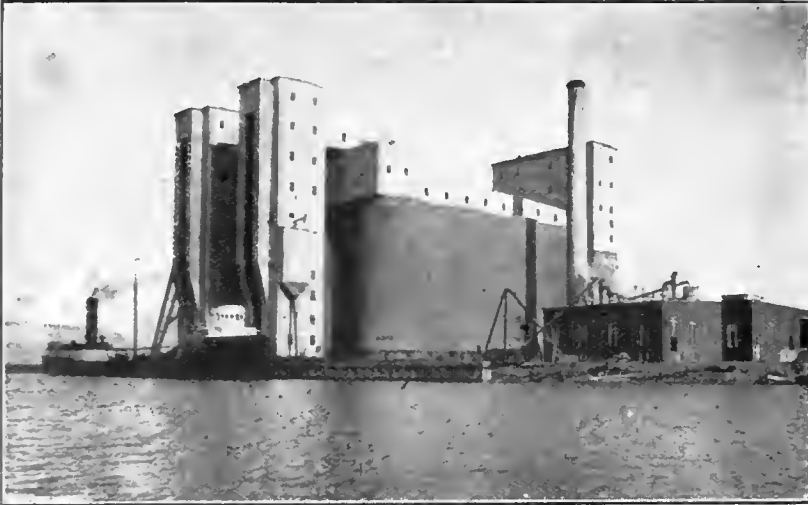

C.P.R. GRAIN ELEVATOR AT PORT McNICHOLL, ONT.

take care of the vast volume of business offering an addition was at once absolutely necessary. Steps were, therefore, taken to provide this by building another storage unit of equal capacity to the original.

The New Storage Unit.

The new storage unit is an exact duplicate of the first, and was com-

pleted in time to be filled with the 1911 crop before the close of lake navigation. The walls of the bins are 80 feet high. The entire structure is of steel and concrete. The two marine towers which traveled along the side of the original elevator fill also the new storage unit. Each marine tower is 150 feet in height and consists of structural steel covered

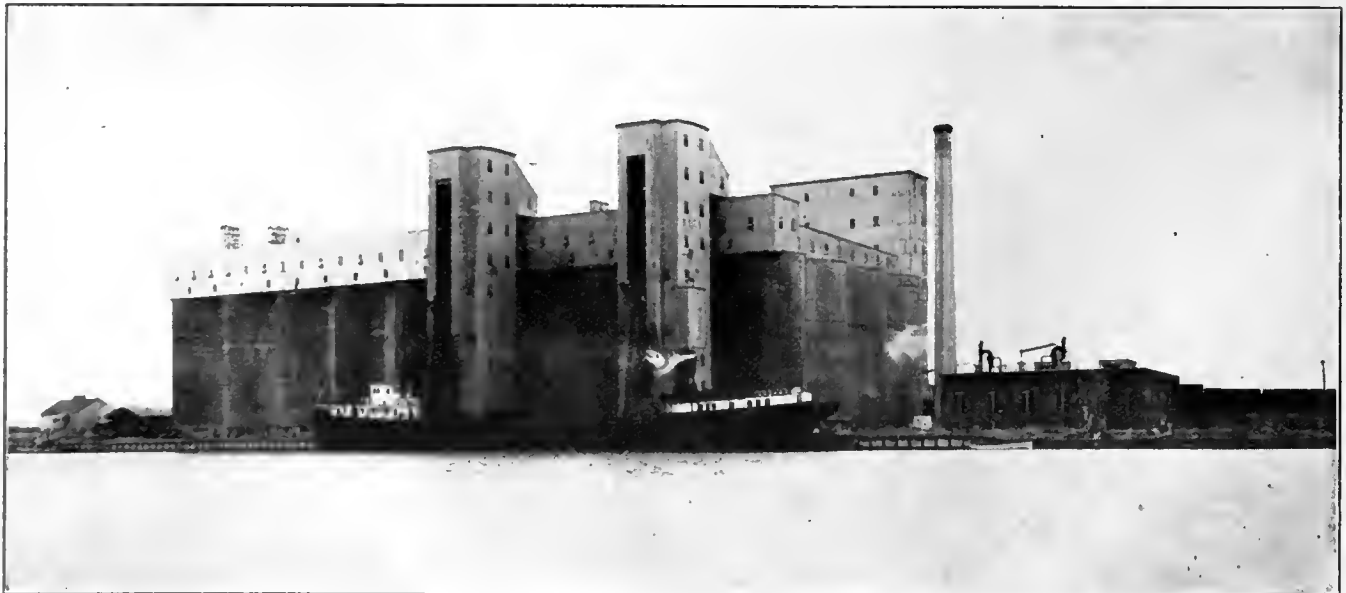

C.P.R. ELEVATOR AT PORT McNICHOLL, ONT., WITH NEW STORAGE ADDITION COMPLETED.

right in Figs. 1 and 2. There are installed two Westinghouse-Parsons steam turbines, direct connected to generators; the plant having a capacity of 1,500 horse-power steam at 160 lbs. pressure, is supplied by six Babcock & Wilcox water tube boilers of 250 h.p. each. The smoke stack, of reinforced concrete, is 160 feet in height. Besides supplying motive power, the plant takes care of an elaborate system of incandescent and arc lamps, making night operation as easy as that of day time.

There are about 1½ miles of wharves altogether, and it is planned to add storage units whenever the volume of business renders these imperative, there being adequate room for future exten-

Metcalf Co., engineers, of Montreal and Chicago.



ART OF INDUSTRIAL MANAGEMENT—MINORITY REPORT.

By H. H. Vaughan.

I AM unable to sign the majority report in its entirety, much as I admire the thoroughness with which it has been prepared and its great interest. In its general tenor it distinctly implies the desirability of what is termed labor-saving management, involving the planning department, functional organization and the bonus system. Perhaps this statement is not strictly justified, but I can-

classify these for us, perhaps even explain their advantages and limitations so that we may in time know which is preferable and when.

No Particular System of Labor-Saving Management.

The introduction of the use of these methods has been attended by claims as to results that might be obtained by their use, and these claims have led to such absurd statements as that made before the Interstate Commerce Commission. I feel most strongly that each of the suggestions that have been made to improve methods of management may have merit, but I do not feel that any one of them is a panacea for all our inefficiency. For

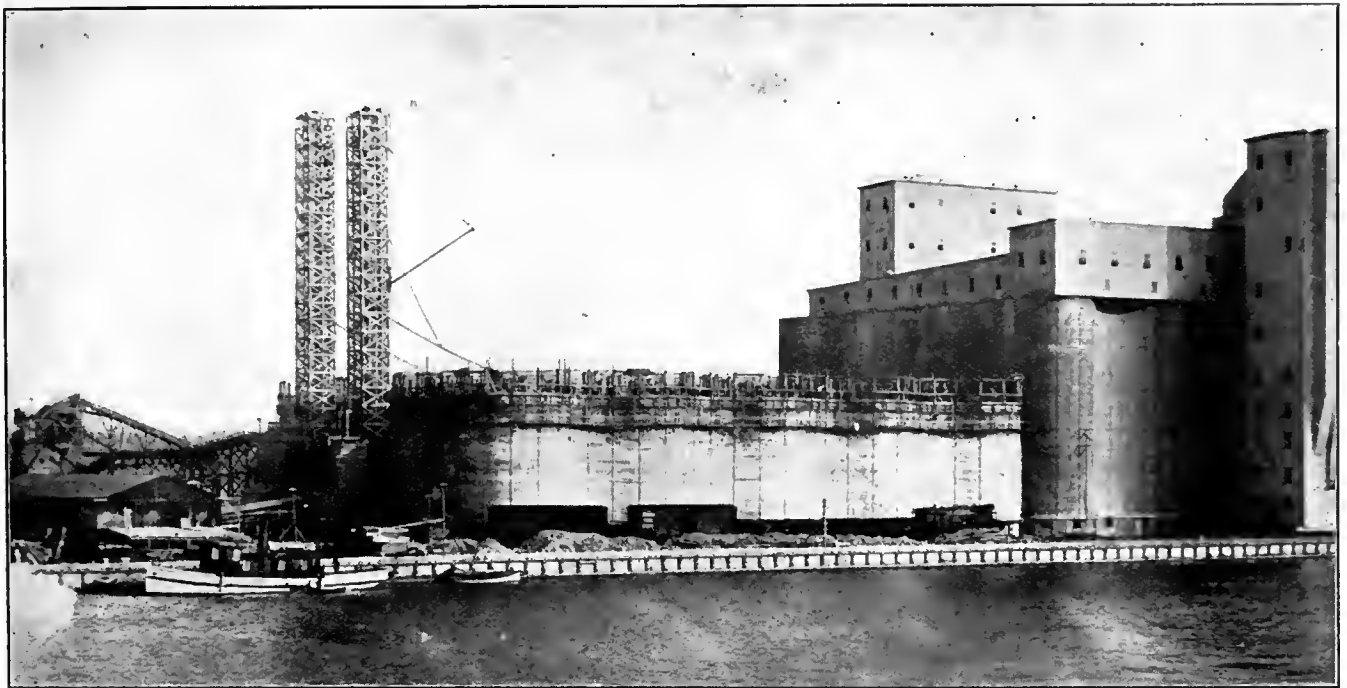

C.P.R. ELEVATOR AT PORT McNICHOLL, ONT., WITH NEW STORAGE ADDITION UNDER CONSTRUCTION.

sions up to 10,000,000 bushels capacity. The entire plant is fireproof, for, excepting the transmission ropes, there is nothing combustible about it. All the windows have wired glass, and metal conduits have been provided for the electric wiring. A fire pump supplies water to the various hydrants placed throughout the elevator.

The plant has a flour shed, 700 feet long, and also a freight shed, of the same length. There is a carpenter shop, a coal platform, a pump house and a Customs house. In addition, a sleeping house and an eating house have been provided for the freight porters. The construction work was carried out under the supervision of J. M. R. Fairbairn, assistant chief engineer of the Canadian Pacific Railway, and C. W. P. Ramsey, engineer of construction for the company; while the structure was designed and erected by the John S.

not avoid the impression after reading the report most carefully. That the methods of management have undergone a great change in recent years I certainly agree, and would explain it by stating that in many respects the art of management is developing into a science.

In common with most lines of work, the method of investigating facts has changed. Phenomena are analyzed, information is obtained accurately and the mental attitude of the manager is scientific rather than empirical. Things that used to be known generally by gradual experience are now known specifically by detailed observation. In the course of this development many new systems and ideas have been invented, time studies, motion study, payment systems, functional management, etc. Some are new, others partly new, others simply practices of many managers put into definite form. The science of management will

instance, in certain classes of work, time studies are valuable, in others they may be a waste of time. In certain classes of work I consider piece-work or bonus system desirable, in others I consider them inferior to day work. Functional management may be an improvement in certain industries, in others I do not consider it suitable.

In general, I feel that labor-saving management is not any particular system, but will always remain the art of selecting and applying the most appropriate methods furnished by the science of management, the science that records what these methods are and the results obtained from them.



Cranbrook, B.C., is in search of a city engineer. Applications to T. M. Roberts, city clerk.

Judging of Results in Technical Journal Advertising

By R. Bigelow Lockwood

This article discusses the many sidedness of the advertising proposition, and indicates, by featuring a number of typical examples, a few considerations to be accounted when measuring up the value return of the particular medium or mediums employed. Advertisers and subscribers alike will benefit by a careful perusal of the data given.

THE story is told of a young man who courted a certain girl. It happened that this young lady had three sisters, all of whom closely resembled her. When asked how he told the sisters apart, in order to be sure he was making love to the right one, the young man replied, "I don't try."

A great many advertisers, especially technical journal advertisers, assume very much this same attitude toward the question of "results." Instead of determining what sort of results are best for their particular proposition, and then exerting every effort toward securing them, too many advertisers are using the hit-or-miss method. Either all results look alike, or else no attempt is made to analyze them.

There is scarcely a word used in connection with advertising which is as flexible in meaning as the word "results." Certainly it is difficult to find a word which may mean so many different things, or which is so hard to define.

The Personal Equation.

The reason for this is obvious. No two human beings are constituted exactly alike, and this rule applies with equal force to advertisers. What one advertiser derives from his advertising falls short of the expectations of another. It is, therefore, impossible to set a fixed standard by which to judge and weigh results which will satisfy all. Every business is as individual as the man or men at the head of it, and demands individual treatment to suit its particular need, rather than any "blanket" statement as to what is good for it.

Granted that it were possible to render all business conditions uniform, there would still be the varying personalities and expectations of the advertisers to be reckoned with.

The purpose of this article is not to lay down any fixed table of results, but, rather, to point out some of the different things which advertising accomplishes. By using that which applies to the conditions existing in his own business, the advertiser, and especially the technical journal advertiser, may perhaps be led to better understand and appreciate what his advertising is doing, or should do, for him.

Let us take actual cases for our illustrations.

Indirect Replies.

A manufacturer of grates for use under boilers, whose factory is located in the western part of New York State, advertised his product in one of the leading technical papers read by power plant engineers. His plan of advertising was sound, carefully written from a copy standpoint and based on the logical idea of educating possible users to an appreciation of the distinctive points of superiority about his grate. Under the name and address of his company he ran, in much smaller type, the name and address of his New England agent.

After his advertising had been running for some little time he reported that he had been able to see but few results. Urged to look deeper into the matter before finally passing judgment upon the value of his advertising, he discovered that his New England agent was securing a great quantity of live inquiries and closing some very good orders. Why his advertising was sending inquiries to his New England agent, rather than directing them to the home office, might be explained by an investigation into local conditions; the fact remained, however, that his advertising was actually producing results—a truth which was determined after the advertiser had gone thoroughly into the matter.

This practice of listing agents in advertisements is commonly used among technical journal advertisers, especially in the machinery field. A machine tool builder, for example, whose plant is located at Cincinnati, will be represented by dealers and agents in many prominent cities, both at home and abroad. Often as many as twenty-five or thirty different names, representing as many different agents, will appear in an advertisement, under the company's own name and address, the purpose being to give the agents co-operation and to tell prospective buyers where the nearest agent is located. This naturally influences business among the company's representatives, but unfortunately direct results of this sort are more or less hard to trace, and some manufacturers are apt to complain about a lack of results, not taking into consideration the fact that their advertising is producing business through their agents.

Where a number of agents are listed in an advertisement, it is not fair to judge the efficiency of the advertising merely by the number of replies and the amount of business coming into the home office.

Other Frequent Errors.

Another error into which technical journal advertisers sometimes fall, when judging results, is expecting their advertisements to actually close sales for them.

Technical journal advertising should be looked upon as an introduction to possible buyers, who, through the arguments presented, have become sufficiently interested in the proposition to write to the advertiser for further particulars.

If a technical journal advertisement accomplishes this, it has achieved its purpose. An advertisement in a technical paper has produced results if it brings manufacturer and possible buyer together. The subsequent closing of the order is a matter for which the advertiser must be responsible.

This must not be taken to mean that technical journal advertisements do not often produce orders without effort on the part of the manufacturer. I could cite many instances where machines and devices have been ordered by long distance telephone as a direct result of some one particular advertisement—but this does affect the statement that a technical journal advertisement has accomplished results when it points out to the advertiser the location of possible buyers.

In short, if a technical journal advertisement is producing live inquiries, it is producing results. After these inquiries get into the hands of the manufacturer, it is up to his follow-up system and his sales force to turn them into orders.

Advertising and a company's selling force, should work hand in hand, and the right kind of advertising will make the salesman's work easier. Yet this is something which the technical journal advertiser often does not appreciate, and, consequently, in many cases fails to give his advertising proper credit for showing results.

Suppose we make this clear by using a typical illustration which will apply to any manufacturer who employs a sales force.

How Results Come About.

The "B" Company, manufacturers of the "B" automatic stoker, decides to enter into an educational campaign of advertising. As a medium for this advertising, one or more technical papers reaching power plant engineers are selected.

The idea behind the "B" campaign is the logical one of educating engineers to a realization of the strong points in favor of the "B" stoker. Each advertisement takes up one educational feature and explains its advantages in detail. Adequate space is used in which to tell the story, and perhaps an educational hooklet on "The Advantages of Automatic Stoking" is offered.

Inquiries from the advertising begin to come in, many of them being merely requests for the book. These are the tangible results the "B" Company sees from its advertising, and the advertising is judged accordingly. There is a deeper influence at work, however, and because it is not seen it is often likely to be overlooked. In order to discover what this is, let us jump half-way across the continent and see what is happening in the power plant of the Michigan Erie Lighting Co.

William Connors, chief engineer, is typical of the modern progressive type of power plant engineer who reads at least one technical paper as a matter of personal duty and education. Like other men of his type, the advertising pages of this publication are considered as valuable by him as the editorial section. He reads advertisements in order to keep in touch with the latest power plant devices, with one eye cocked for anything that will enable him to operate his plant with greater economy, and so demonstrate to his employer his own value as an efficient engineer.

For quite a long time Bill has been considering the question of installing automatic stokers. The thing that started him thinking about it was a statement made in an advertisement of the "B" Company, regarding economy. This happened over six months ago, and ever since then Bill has been carefully debating. Each week, when his technical paper arrived, that ad. of the "B" automatic stoker interested him and he read it through. Once in a while he would skip it, but somehow he would always drift back to it again. After a few months of this he had a pretty good idea of the superior points of the "B" Company's device, although he would never allow himself to frame any decided opinion.

Other automatic stokers were advertised in Bill's paper, and he got into the habit of reading their ads.; but somehow they failed to give him the definite information he desired, while

all the time the advertisements of the "B" Company were hammering in new points.

How a Decision was Reached.

The day finally arrived when Bill decided to act. Convinced that his plant would show higher efficiency and greater economy with a system of automatic stokers, he secured permission from the "old man" in the big leather chair to "go ahead."

Now, Bill wanted to give all the manufacturers of automatic stokers a fair show, because he hadn't made up his mind which one to install—at least he thought he hadn't—so he wrote to half a dozen concerns for full particulars about their product, not mentioning where he had seen their ads.

The first salesman to reach Bill was a fellow from the Economy Stoker Co.; what he said about the Economy stoker sounded all right, but somehow Bill wasn't quite satisfied. There seemed to be something missing from his argument, and although the Economy chap was a remarkable talker, Bill decided to wait.

The same thing happened to the next two salesmen—a fluent man from the Alert Company, and one from the American. Both talked themselves hoarse, and although Bill had to acknowledge that their arguments were good and their guarantees liberal, something held him back from acting. After they had gone he realized that what he really wanted was a chance to hear what the "B" Company man had to say.

The next day the "B" man arrived. He came with the expectation of having to talk his head off, but to his surprise Bill seemed to know all about the "B" automatic stoker. Instead of having to start at the beginning of his story, as the other salesmen had done, and work up to a climax, the "B" salesman found that the introductory part had already been accomplished. Not having to waste time getting Bill interested in the life history of the "B" automatic stoker, the order was finally closed and the salesman left with a contract.

When the "B" Company received the order, the sales manager gave it out that Mr. Duffy was certainly a bright salesman to get the contract away from five competitors.

"I wish our advertising was doing as well," said the president of the company, who also carried upon his shoulders the responsibility of the advertising. "I can't see that we are getting many results from it."

The imaginary case which has just been outlined is one which is actually occurring every day. The technical journal advertiser who is far-sighted will give his advertising credit for a great deal more than he is able to place

his finger upon, and one result, which, though unseen, yet nevertheless real, is the valuable assistance the right kind of advertising is able to render in making easy the way for the salesman.

A Peculiar "Test."

An amusing incident, which actually happened, will serve to illustrate the next point.

A certain manufacturer of rubber sheet packing, whose ideas regarding advertising were at least original, though vague, used as a business card a small square of his product, on which was printed his name and address. These cards were distributed by him very freely, and for a while all went well.

One day a friend entered the manufacturer's office and found him in a state of great excitement. Being a German, with insufficient supply of English, made it all the more difficult for him to express himself properly, but finally he calmed down sufficiently to tell the cause of the trouble.

"Vot you dink!" he exploded. "I gives out dose packing business cards, undt to-day I goes again to a place vere I had been before. And vot you dink! Dot feller had cut up dot eard I left with him and vos testing it out in a flange!"

It often happens that technical journal advertisers make very much this same sort of mistake by not properly applying the kind of treatment which is due the man who answers their advertisements. In many cases where an advertiser claims that he is not securing results from his advertising, the trouble is due to a wrong appreciation of the inquirer's motive or an inability existing somewhere within the organization to handle the inquiry correctly.

Take for example what happened in the case of a large machinery concern which advertised to give free of charge a copy of their handsome new catalog. The main office of this company was in the middle west, with branches in New York and other large cities. Only the address of the home office, however, was given in the ad.

Handling Inquiries Carelessly.

Among those who wrote for the free catalog offered was the superintendent of a machine shop located in Jersey City, across the river from New York. After waiting a considerable length of time for an answer, this man's original letter was returned to him by the New York office of the concern. Across the face of the letter was the red imprint of a rubber stamp bearing the address of the New York branch, while below this was hastily scrawled in pencil the following brief command:

"Come to this office and get the catalog."

Just this; nothing more.

Did this superintendent take the time away from his work to cross the river, hunt up the office of the company and get the catalog? He did not! Instead, he condemned the machinery concern to a climate where ice is unknown. In this case the advertising produced results with a back action effect closely resembling the kick of a playful mule.

In this article we have attempted to point out a few of the things which technical journal advertising accomplishes, and which are sometimes overlooked by the advertiser when judging results. Almost equally important is the ability of an advertiser to correctly analyze the value of inquiries. There is more in a list of names than is perhaps imagined, and if an advertiser analyzes such a list, built up from inquiries and answers to his advertisements, many surprising things will be discovered.—Advertising & Selling.



WORKMEN'S COMPENSATION.

MR. Norman A. Keys, representing the legal department of the Canadian Manufacturers' Association, issued a statement on Saturday, March 22, explaining the position of the association with regard to the draft bill of the Workmen's Compensation Commission.

"Since the appointment of the Commissioner, some three years ago," says Mr. Keys, "the Canadian Manufacturers' Association has made every effort to further the inquiry. It has, at considerable expense, brought experts from other jurisdictions, not in support of any particular interest of employers, but in order to profit by the experience of other countries and to secure a model Act embodying the best results of this experience.

"The result of the inquiry was that the representatives of the employers and those of the workmen had reached practical unanimity upon every question except the amount of compensation, which question would naturally be the subject of difference of opinion, and perhaps just as naturally a subject for reasonable compromise.

Where the Real Issue Lies.

"The real issue is not with the workmen, but with the employers' liability interests, supported by the C.P.R. and other railway companies, which at a late stage in the inquiry came forward with representations in opposition to the system which had been proposed, and in favor of a system in which employers would be individually liable and would

be driven to seek protection by insuring in private companies.

"The objection of the Canadian Manufacturers' Association and other organizations of employers of the Province to the Draft Bill brought down is, that in order to meet the views of the railway companies, the bill has been drafted so as to render it unjust and oppressive to other classes of employers, in fact they are convinced that it is impossible of successful operation.

Proposal of Association.

"The Canadian Manufacturers' Association has placed in the hands of the Commissioner a definite proposal of a system which would afford benefits over twice as large as those of any other Province of Canada, and, in fact, as large as or larger than any system in the world. This, the Association thinks, should be a sufficient guarantee of sincerity. What is objected to, and in this the Association is supported by the other organizations of employers throughout the Province, is that in order to meet the views of those relatively small special interests, an Act should be adopted which would be obnoxious to employers representing 85 per cent. of the payroll of the Province.

"The association has repeatedly expressed itself as more than willing that an Act of an advanced type, such as, for instance, that of the State of Washington, should be adopted, but a careful examination of the proposed Bill has convinced the committee of the Manufacturers that the Bill is unworkable and that its adoption would mean merely an unnecessary repetition of costly and unsuccessful experiments, the results of which have been conclusively proven in other countries."



LUBRICATION OF MACHINE TOOL BEARING SURFACES.

From "Machine Tool Engineer."

IN considering the subject of the lubrication of the bearing surfaces of machine tools, such as the saddle of a lathe, the ram slide of a shaping machine, and the V's of the table of a planing machine, it is rather surprising to note how few designers have departed from the old method of applying the lubricant, in which the workman floods the flat surface with oil and, if it is a lathe he is using, works the saddle backwards and forwards until an infinitesimal portion of the oil has found its way into the desired place, whilst the remainder flows on to the floor or some other undesirable place. The object of lubricating the flat surfaces, which are generally proportioned so that their area bears some relation to the load, is,

of course to lessen the frictional losses, thereby reducing the horse-power required, and to prevent "seizing" from taking place.

In slowly moving parts of machines, such as lathes and millers, the horse-power absorbed is very small, and therefore does not warrant any great expenditure of oil. In proof of this, experiments were carried out on a 6 inch S.S.S. lathe taking a cut, and although it was found that twice as much power was absorbed by an unlubricated saddle, there was little difference between lubrication by wiping down with a greasy rag and lubricating by the old method of flooding, the greatest horse-power absorbed, unlubricated, being only 0.0015. With more rapidly moving machines, such as planers and shapers, there is probably more danger of "seizing," but on the other hand, the lubricant is carried away more rapidly when applied by flooding.

The experiment referred to above seems to indicate that pad lubrication would be suitable and more economical in many cases, and it is to be noted that a few firms have adopted this method for their lathes and millers. A pad of felt—soaked in oil—is carried by the sliding part so that it moves to and fro on the bed and lubricates same.



TRADE BETWEEN CANADA AND BRITAIN.

OFFICIAL returns give the value of the trade between the United Kingdom and Canada during the month of February in the under-mentioned articles as follows:—

Imports From Canada.

	Feb. 1913.	Feb. 1912.
Wheat	£405,413	£509,400
Flour	160,251	162,513
Cattle		9,961
Bacon	68,086	80,467
Hams	23,363	11,637
Cheese	52,506	75,717
Canned Salmon ..	89,939	210,453
Lobsters	17,178	7,495
Hewn wood	4,342	320
Pulpwood	943	5,619

Exports to Canada.

Spirits	52,491	24,210
Sugar	3,601	8,880
Wool	12,342	5,352
Pig Iron	5,717	4,687
Wrought iron	7,656	5,561
Wire	2,804	5,692
Galvanized sheets ..	31,152	14,034
Tinned plates	14,903	17,021
Cutlery	5,111	4,952
Hardware	8,390	5,455

MACHINE SHOP METHODS ^A_N^D DEVICES

Unique Ways of Doing Things in the Machine Shop. Readers' Opinions Concerning Shop Practice. Data for Machinists. Contributions paid for.

HIGH SPEED STEEL ECONOMY.

By Chas. Hattenberger.

IN Vol. VIII, page 83, of Canadian Machinery, appears an article by E. Bates, entitled "Economy in High Speed Steel." He describes a reamer made by brazing a soft steel shank onto a high speed steel tip or cutter. While I believe the method advocated by Mr. Bates would effect quite a saving of steel, I think it would prove advantageous to use any of the three methods

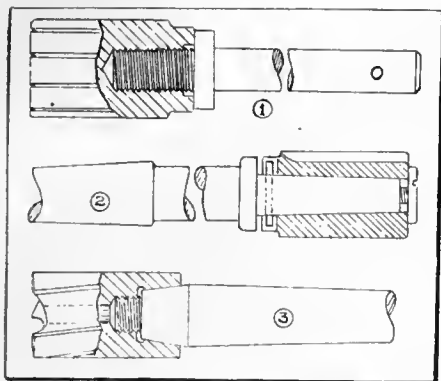

HIGH SPEED STEEL ECONOMY.

illustrated in Figs. 1, 2 and 3. My reasons for so saying are as follows:

If the tips are made interchangeable, they can be produced in half dozen lots, and kept in stock. Then, if a tip showed undue wear or broke, it would only be necessary to remove the old tip and substitute a new one, which would consume but very little time. The method advocated by Mr. Bates, makes necessary the removal of the old tip by heating.

This would take up more or less time, without regard to that required in fitting a new tip by brazing and grinding.

In Fig. 1 is shown a high speed steel tip screwed firmly on a soft steel shank. A tip or cutter of this kind is well adapted for a floating type reamer.

Fig. 2 shows a type of reamer which can be purchased from dealers in machine tools and supplies. It is centered by means of a taper on the end of the shank, and prevented from turning by means of a pin. It is also secured by means of a screw shown.

Another method worthy of note is illustrated by Fig. 3. This, however, is an end milling cutter screwed on a soft steel shank, and centered by means of the taper shown. It will be noticed that a hole extends through the cutter, this being done to save the expense of annealing and recutting the flutes in the end of cutter. By having a hole extend

right through, they can be ground deeper, using the cutter grinder. The hole also acts as a reservoir for oil or other cutting compound.



IMPROVED STEEL COUPLING.

A NEW form of flexible coupling, made entirely of crucible cast steel and to dimensions especially suitable for this material, has been introduced by McEwan Bros., Wellsville, N.Y. This McEwan coupling illustrated herewith, is said to have the smallest diameter and mass, and, therefore, the smallest inertia of any truly flexible coupling on the market. The keys are set at right angles through the shaft, to permit a marked degree of misalignment, yet because of ample key bearing surface and exceptionally good lubrication from packing of heavy oil or soft greases, there is no noise or tendency toward serious wear. The design is particularly good for withdrawals parallel to the shaft axis, and very small clearance is required for removing any part.

This type of coupling was first used and has been given its severest test upon McEwan Bros. pumps direct connected to steam turbines running 24 hours per day for months at a time. The satisfaction which it has given under these high speeds and other severe conditions

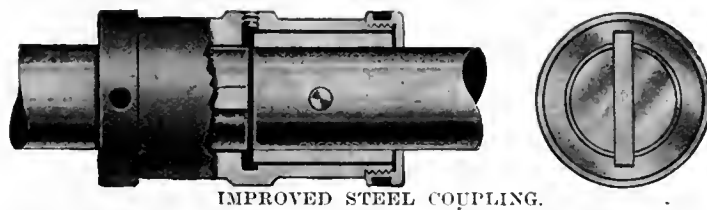

IMPROVED STEEL COUPLING.

such as reversible motor drives for machine tools, would seem to indicate a general usefulness for blower, rotary pump, motor, generator, turbine and line shaft connections, and for other machinery running at high speeds.



A DRILL JIG.

By A. L. Monrad

IN making a drill jig the designer generally keeps two things in view, viz., lightness and quick operation, but too seldom stops to think what the ultimate cost of the jig will be. The latter, being

most important factors, should always be given due consideration in tool designing.

The jig here shown embodies all these points in its design, and has proved entirely satisfactory in service.

The casting (A) was planed and finished to the form of the model, then the 1/2-in. hole (B) was drilled for lightening purposes. Fastened to (A) by two fillister headed screws is a steel piece

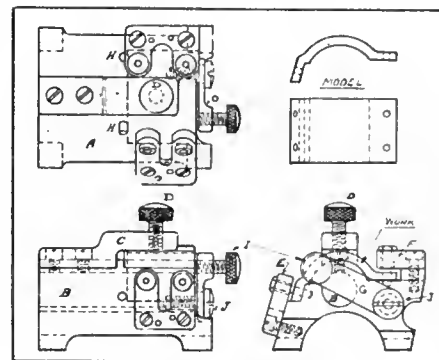

A DRILL JIG.

(C) through which passes a 1/4-in. knurled screw (D) for holding down the of (A) by the shouldered serew (J) is the arm (G). This carries the knurled screw (I), which pushes work against the locating pins (H).

It will be noticed that the plates (E) and (F) which carry the drill bushes, are

secured by two fillister headed screws and are doweled in position.



The Schaefer Brick Co., of New Hamburg, Ont., has been organized with the following directors: Fred Schaefer, Maurice Schaefer, Edward Merner, Senator Ratz, and John Sloan, of Galt. The new company will enlarge the present brick making plant and go into the manufacture of red pressed brick on an extensive scale. The company have lately purchased some land from Mr. Henry Schaefer, where they will get the clay for the red brick.

BORING A 30-IN. SLUICE VALVE FOR SASKATOON WATER-WORKS.

By D. M. Bright.

THE faucet on the valves was $\frac{3}{4}$ -in. too small in diameter for the spigot of the pipes, and as the valves were urgently required, the services of John East, proprietor of a small foundry and machine shop in Saskatoon were requisitioned.

The accompanying sketch shows how the job was set up, an interesting part of the work being that of fixing the valve to the ground. This was accomplished by one of the simplest "chucking" methods yet discovered. The valve was set up, one face on the ground and banked round with snow, to which was added a few buckets of water. This soon froze solid, the temperature being 48 degrees below zero, and, needless to say, there was no movement of the valve during the boring. The boring bar was a piece of 3-in. mild steel turned and screwed where shown, 12 threads to 1 inch. It served as feed screw, and also to hold the boring plate, which was the face plate of lathe held secure by nuts at top and bottom. To this plate was fixed two cutting tools, as shown. The feeding was done through the east iron plate screwed to fit boring bar and bolted to top of planks, the latter being held in place by struts and tie bolts. On the upper end of boring bar was keyed a strong cast iron pulley, with a piece of timber to hitch the horse to. The guide for bottom end of boring bar was

a plain three-winged casting, with lugs to take set screws for centring, having a boss in centre bored to fit bar, and long enough to allow for full travel of cut without the bar coming in contact with gate of valve. When the job was set, the horse was started, and the men returned to their other work in the shop, only keeping a look out now and then to see that he was still going. Two cuts completed each faucet, and the

VALVES IN PIPE LINES.

WRITING on "Valves in Pipe Lines" in the columns of the Power User, Mr. J. S. Leese points out that the abuse of valves is a common cause of accident in the steam power plant. A valve in a live steam line, he maintains, should never be opened or closed quickly. In one recent accident a stop valve chest exploded under water



BORING 30 IN. SLUICE VALVE, CHUCKED TO EARTH AT TEMPERATURE 48 DEGREES BELOW ZERO.

work was so smooth that a groove had to be made to hold lead.

Three faucets were bored out in four days, which time included making of tackle. The horse was an old timer, having served ten years with a local contractor on capstan work shifting buildings. The writer secured photo and data of this job when visiting Mr. East's shop, and considers it as clever a bit of work under the conditions as he has ever seen.

hammer set up by turning live steam into a cold and badly drained steam pipe. In another case an explosion occurred owing to unbalanced pressure at the initial opening of a boiler shop valve. This raises the question, why should not all valves on live steam lines be provided with by-passes? The extra cost would be justified by the lessened risk to life and property, and where there is admittedly such a risk it would appear to be almost criminal not to take every possible precaution to guard against accident.

A prolific cause of accidents, Mr. Leese goes on to explain, is the tightening of leaking valves with spanners and crowbars. A recent case, resulting in the killing of one man and maiming two more for life, occurred when a valve yoke broke under this treatment, allowing the steam to lift the throttle and carry the water of condensation into the steam chest, blowing the steam chest cover out by the force of its impact. A valve should in no circumstances be closed further than it can be with the hand-wheel supplied with it; if it leaks then, it is high time to take it down and examine it for the cause of the leakage.



George W. Thompson, who was superintendent of the light and power department of Westmount, has been appointed acting manager of that city's affairs until November next. His salary will be \$5,000. The new position is really that of city controller.

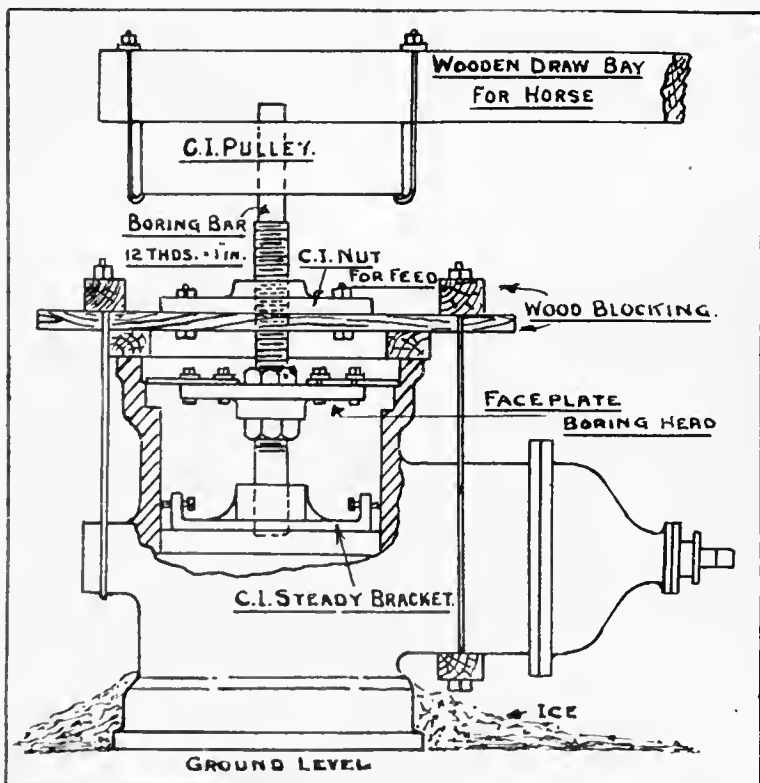

BORING FAUCET OF 30-IN. GATE VALVE.

DEVELOPMENTS IN MACHINERY

A Record of New and Improved Machinery Tending Towards Higher Quality and Economical Production in the Machine Shop, Blacksmith Shop or Planing Mill.

SILENT CHAIN TRANSMISSION OF LARGE POWERS.

By W. E. Meadwell.

MANY engineers who have been wont to specify only belt-drive or gearing of which they knew the efficiency, durability, etc., for service entailing quick stops and starts, variable motor speeds, jerking between centres, etc.,

silent action, high efficiency and durability of the silent chain has attracted more than ordinary attention on the part of users.

We are able to show a series of pictures of silent chains used in the Mechanical Rubber Co.'s Works, Cleveland, O., and they are a representative group of many others installed. In general,

new gum, is very severe, the load often varying from 25 per cent. to 150 per cent. of normal in a few seconds.

Figure 1 shows a rubber mill or mixer which, with others on the same shaft, is driven by a Westinghouse 200 horsepower constant speed induction motor. The double chain of this particular mill is of the Morse silent "rocker joint"

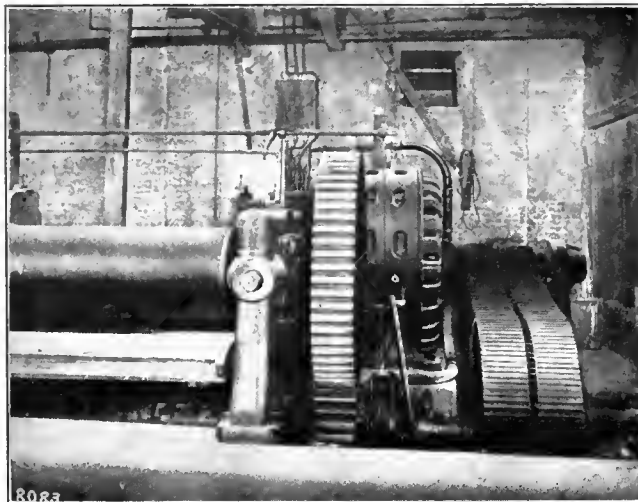

FIG. 1. SILENT CHAIN TRANSMISSION OF LARGE POWERS.

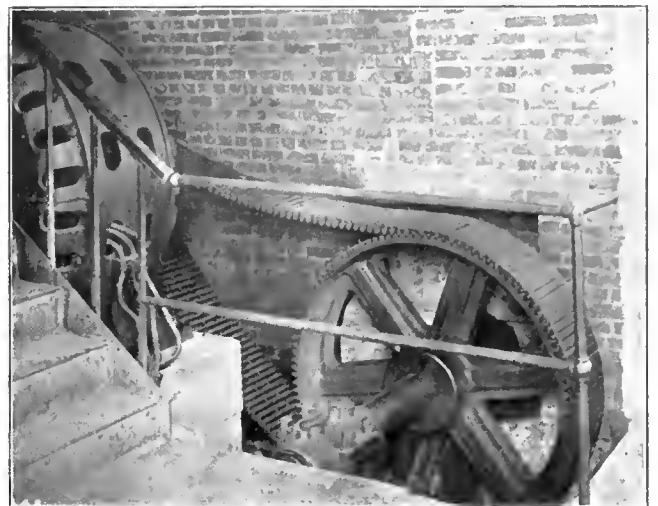

FIG. 2. SILENT CHAIN TRANSMISSION OF LARGE POWERS.

will undoubtedly be interested to know that there is one type of silent chain which has been performing just such and probably more severe service for some years. It is a fact that gearing has been very largely used for this service heretofore, but the smooth-running,

the process of rubber manufacture consists of washing the gum, mixing, compounding, calendering, forming or molding to shape and curing. Practically all of the work is done by rolls of various sizes and arrangement. The service, especially when washing or mixing

type, 10in. wide, 11 $\frac{1}{2}$ in. pitch, with a speed of 1,250 feet per minute at the highest motor speed. The sprockets, of 23 and 117 teeth, with speeds of 435 to 85 r.p.m., are set at 84-inch centres.

The drive on these machines is subjected to very severe service from the

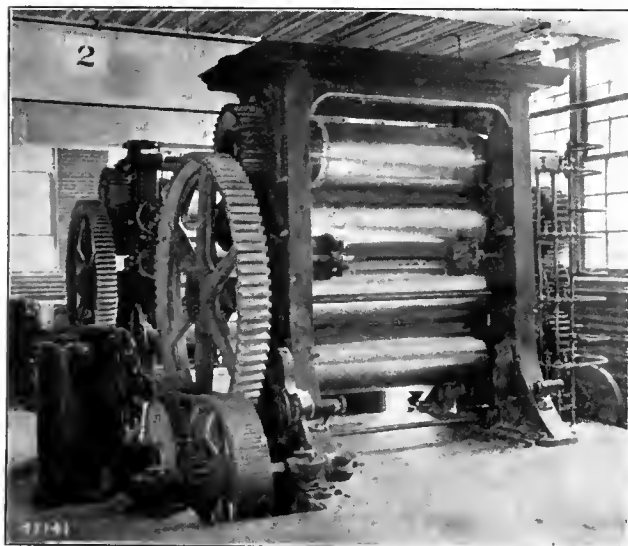

FIG. 3. SILENT CHAIN TRANSMISSION OF LARGE POWERS.

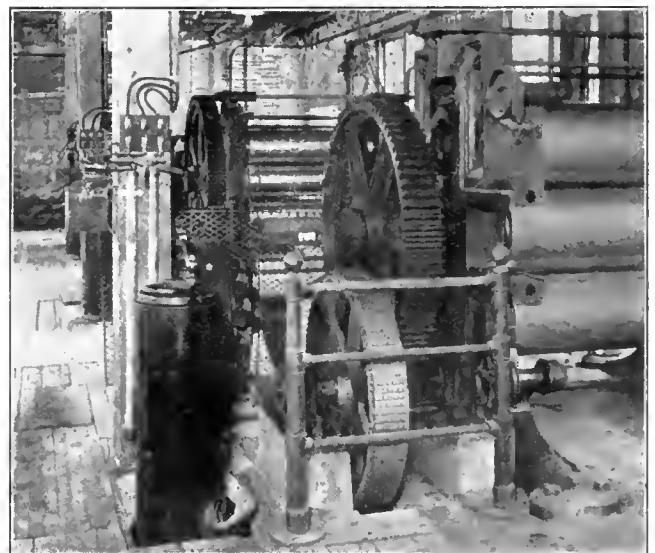

FIG. 4. SILENT CHAIN TRANSMISSION OF LARGE POWERS.

uneven load, due to the rubber being run through the rolls in bunches or lumps, yet it has given more satisfactory service than gearing, which has always heretofore been used on this type of machine. The chains show no bad effects, nor have any repairs been necessary.

Fig. 2 shows a 150 horse-power Morse silent chain driving another mill line in the same plant, the motor being placed outside the mill room. The chain is 15 inches wide, $1\frac{1}{2}$ inches pitch, and the sprockets are set at 84-inch centres. The motor is of Westinghouse constant speed induction type.

Fig. 3 shows, in the foreground, one of a battery of four-roll rubber calenders, each driven by a 75 horse-power Morse silent chain from a Westinghouse A.C. four-speed induction motor. The chain is 1.2 inches pitch by 9 inches wide, sprockets of 21 and 105 teeth, with speeds of 690 to 138 r.p.m. being set at 54-inch centres.

Fig. 4 shows a three-roll calender driven by a 50 horse-power Morse silent chain from a Westinghouse motor. This chain is 1.2 inches pitch, 6 inches wide, with a maximum speed of 1,450 feet per minute. The sprockets are of the same number of teeth and speeds as for the four-roll calenders noted above. These calenders are for making friction cloth and rolling out sheet rubber. While the load is more even than on the mills or mixers, the frequent stoppings, changes from one speed to another, etc., still work hardships upon a chain or other drive. There have been no repairs of any kind to these calender chains since their installation.

There are two sources of current available at this plant, and by using a drum type controller the different windings of the calender motors are thrown alternately on the two circuits, and speeds of 255, 345, 510 and 690 r.p.m. obtained. Any of the above speeds may be used for continuous operation, as required by the quality of the stock being calendered.

The illustrations and details here given are simply to show that silent chains are now being used in service for which only gearing was formerly considered; and the fact that there have been no repairs since their installation proves their superiority over the old form of drive. For the past ten or twelve years chain driving has been returning to favor owing to the advent of the silent flexible type, and it has come to be recognized as standard transmission in connection with electric motors up to 100 horse-power. Engineers of the "old school" are now recognizing that the advantages it offers in drives of smaller powers are applicable also to drives of 3,000 h.p., upwards.

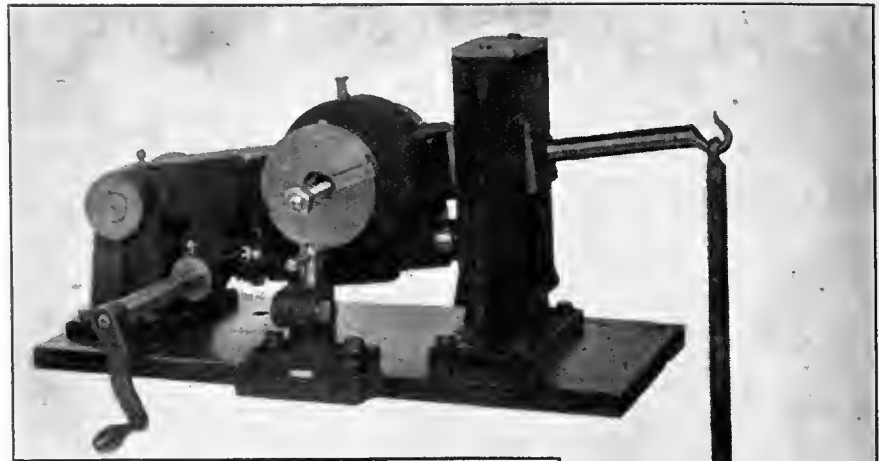

FIG. 1. FACE CAM CUTTING FIXTURE.

6-IN. FACE OR BARREL CAM CUTTING FIXTURE.

OFTTIMES it becomes necessary to cut a cam and where the quantity is not sufficiently large to warrant buying an entire machine, the design of the attachments shown is such that they will readily fit any standard knee type of milling machine. They have power feed, and being made on the reversible order.

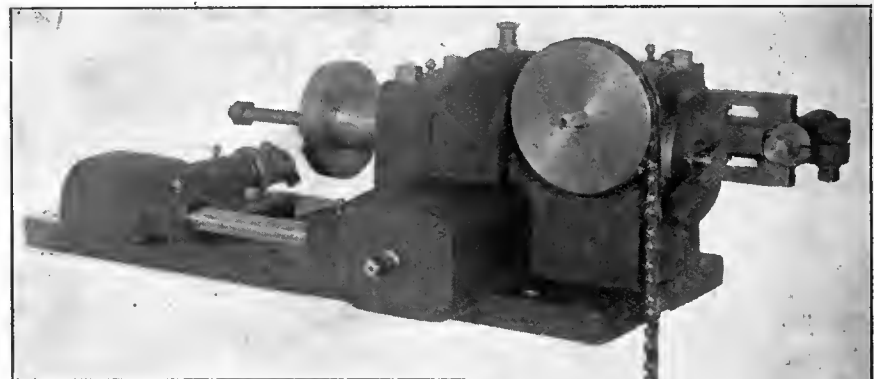

FIG. 2. BARREL CAM CUTTING FIXTURE.

the universal feed joints can be brought to the attachment either from the front or rear side of the milling machine frame.

Fig. 1 shows the attachment for cutting face cams on Fig. 2, shows the barrel cam cutting attachment. Both have a capacity of 1- $\frac{1}{2}$ in. to 6 in. cams, and are the product of the Garvin Machine Co., Spring and Varick Sts., New York City. The boxed weight for shipment is about 225 lbs.



Jackson & Savage, Limited, incorporated at Ottawa with \$450,000 capital to manufacture boots and shoes at Montreal: Incorporators, Wilfred Bovey, Robertson Fleet, Joseph Alphonse L'Heureux, Harry Ellis, Lillian M. Gamble, Edith H. Delight, all of Montreal.



4-PLANE SHELL DRILLING MACHINE.

THE machine, Fig. 1 and 2, has been recently designed by the Langelier Mfg. Co., Providence, R.I., for drilling simultaneously four holes 3-32 in. diameter, 90 degrees apart through the walls of a brass shell .410 in. diameter, 2½ in. long, and ½ in. from end of shell. With it, an output of 15 shells drilled with four holes each was obtained during the makers test before shipment being an output if maintained continuously for a 10-hour day, of about 9,000 shells.

The machine consists essentially of four drilling spindles working simultaneously, disposed 90 degrees apart around the work at a convenient height for the operator, near the top of a vertical column, the accessory spindle driving pulleys and cam actuating treadle being located at the base. The drill spindle frames are held in the four arms of a cruciform casting which supports a stout trunnion shaft at the rear end in the centre, over which the spindle frame actuating 4 segment edge cam is mounted at the rear together with the driving belt idler pulley brackets, while on the front side is carried the work holding bushing.

The four spindles are simultaneously fed against the work by depressing the foot treadle at the right which imparts a quarter revolution to the edge cam, drawing in the four spindles simultane-

ously by engaging a roller on each drill frame. The withdrawal of the spindles is done mechanically by a spring inside of each drill frame.

Each spindle is hardened and ground and is supplied with two splines for better balancing at high speed. It has bronze and steel thrust washers, as well as a cast iron belt guard over each spindle pulley to prevent injury to the operator in case of belt breakage. The lower vertical spindle is protected completely against chips or dirt by a hood or muffler as shown. The tension of the belt is taken entirely away from the drilling spindles, by having the spindle bushings in the drill frame bearing extend to midway of the pulley width, leaving only the width of the driving key uncovered by the bushings.

The hub of each spindle driving pulley runs on the projections of the bushings thereby relieving the spindles themselves of all belt tension. This construction practically makes each spindle a floating unit, while ensuring great sensitiveness, ease of feed and return, and complete freedom at all times, even if the belt be unusually taut. Each spindle carries No. 11 Skinner chuck for taking drills up to 7-32 in. if desired. One endless leather belt, guided by suitably disposed idlers, drives the four spindles. It is kept at the proper tension by adjusting the large idler pulley at the left of the machine column, vertically, and clamping it in place by the single cap screw shown.

The arrangements made for receiving the work and holding it while being drilled consist of a hardened and ground steel snap bushing into which the shell is put by the operator, and being hardened, it serves at the same time as a guide bushing for each drill. As the shell projects out of the bushing considerably, it is easily put in and pulled out by the operator. The machine stands 69 in. high, 56 in. to the work, weighs 570 lbs., occupies a space 24 in. wide and 28 in. deep. Provision is made so that the depth to which the drills feed into the work may be closely gauged and set as desired. The pulleys on the countershaft are designed for turning at 575 r.p.m., this imparting a speed to the drills of about 2,700 r.p.m. The efficient oiling of every running bearing has been given especial care.

In case the holes require to be staggered in spacing, some of the spindles may be set further in or out from the frame of the machine, permitting some holes to be drilled at a greater distance than others from the end of the piece. Again instead of single spindles the machine may be provided with multiple drilling heads, and a large number of holes

drilled with each spindle and with as many spindles as the work demands. These machines are made in small and large sizes to suit requirements.



THE R. McDougall Co., GALT, ONT.

THE R. McDougall Co. of Galt, Ont., have been compelled to move from their present location, because of its purchase by the Lake Erie and Northern Railway Co., for their main entrance into Galt. They will build new shops as soon as possible. They have already acquired 10 acres of land for a new plant in the north end of the town, up-to-date shops will be built. The capacity of their present machine shop and foundry will be doubled. Most of the shops will be of one storey. Work will begin as soon as possible.



The Canadian Hanson & Van Winkle Co., Ltd., manufacturers of Foundry supplies, West Toronto, Ont., are preparing plans for an addition to their plant, which will double their capacity. The building will be continued out to the front of the street and will measure 225 x 50 feet, four storeys high. Their new equipment is being specially made. Among the new products the firm will manufacture are electro-plating generators, electrical equipment and chemicals.

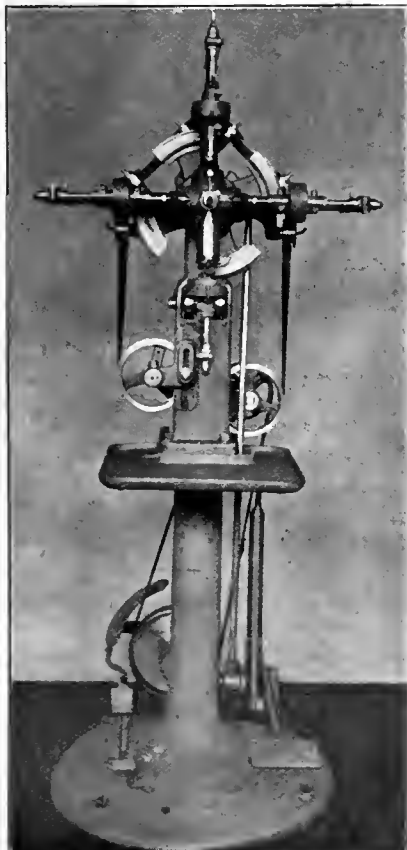

FIG. 1. 4-PLANE SHELL DRILLING MACHINE.

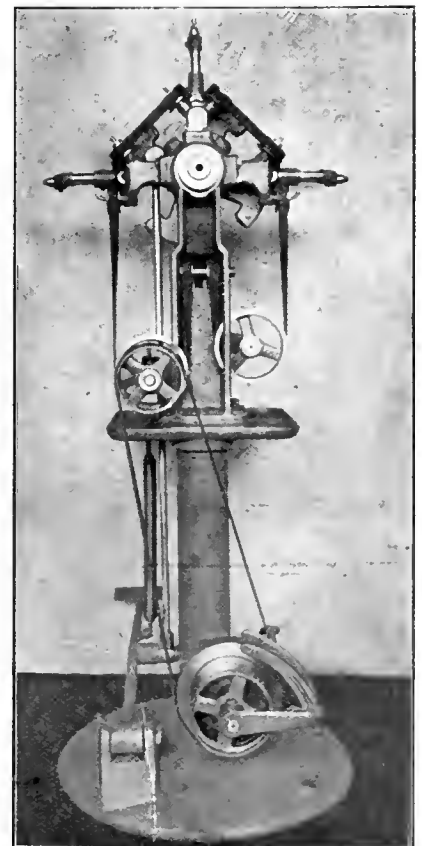

FIG. 2. 4-PLANE SHELL DRILLING MACHINE.

RAILS USED AT PANAMA.

SAMPLES of rails used at various periods on the Panama railroad and canal work have been collected, and may be seen in the office of the Chairman at Culebra. Cuts of cross sections of them are published herewith.

The first track used consisted of flat iron bars laid upon stringers, and this was the rail on the section from Aspinwall to Gatun, 1850-1852.

The inverted U rail, shown in Fig. 1, weighed 53 pounds to the yard, and was the first rail used on the completed railroad, 1853 to 1869.

From 1865 to 1879, the 70-pound wrought iron rail, shown in Fig. 2, was used, and from 1876 to 1907 the first steel rail was used, and is shown in Fig. 3. It weighed 50 pounds.

The wrought iron rail was sold for \$45 per ton, and more than enough was realized from its sale to buy new steel rail, which was purchased in England at 6 pounds 5 shillings per ton.

Figs. 4 and 5 show the Belgian rail used by the French Canal Company in construction work from 1882 to 1899. This rail weighed 50 and 60 pounds to the yard.

Fig. 6 is a cross section of the 60-pound steel rail of American manufacture used by the Isthmian Canal Com-

tween Mindi and Gatun in 1912. The tie is of balsamo and was probably laid about 1884.



ELECTRIC STEEL RAILS.

THE recent purchase of 1500 tons of electric steel rails by the Pennsylvania Lines, in addition to a 500 ton lot which has been in service for some months, and the ordering of 1000 tons by the Erie Railroad, follow uniformly satisfactory results from various tests. During the past two years a number of American railways have had electric rails in service under test. These were placed at the points where traffic conditions were most severe, and not a single instance of breakage is reported, although a few failures developed, due to easily remediable causes.

The fact that the carbon in the electric steel rail can be brought up as high as 0.07 without inducing any tendency to breakage is the key to the exceptional wearing qualities shown by the electric rail in service. It is even anticipated that the carbon content may be raised an additional 10 points. In comparison with the standard Bessemer rail, the results with respect to wearing qualities are particularly gratifying.

The control possible with the electric furnace offers the added advantage with

TESTING LOCOMOTIVES IN THE ERECTING SHOP.

TO avoid the inconvenience of smoke and dirt in the erecting shop it is usual, where there is a running shed located conveniently in relation to a large repair shop, to place locomotives therein when preparing them for the road tests. The operation of firing-up is necessarily attended by the creation of smoke in considerable volume, and this, in the erecting shop, where work is being conducted on other engines, cannot very well be tolerated.

According to the Railway Age Gazette the matter has received attention in the United States, and on the Delaware, Laekawana, and Western Railway a special "firing-up" house has been erected in connection with the locomotive repair shops at Scranton, Pa. This building is situated directly across the transfer table from the main machine and erecting shop, and is used for housing the locomotives while the tenders are coupled on and made ready for service, and while they are being fired-up for trial trips on the road. The building equipped with four tracks, each having a 50 ft. pit of concrete construction, is heated by steam and lighted by electricity. Smoke jacks are provided at the end of each pit so that locomotives may be either headed or backed in.



C.P.R. AND ST. JOHN N.B.

THE C.P.R. announces that it will spend a million and a half in St. John, N.B., and vicinity, during the coming season. The largest single item to be spent will probably be one of about \$630,000, towards the cost of the new grain elevator at West St. John, power house, yard and track facilities in connection with it. The next in size is the appropriation for bridges and culverts which includes the replacing of some large bridges, and renewals and repairs for many smaller ones. The cost of the new erecting and machine shops at McAdam Junction is included, and runs into six figures. Another interesting item is the completion of the automatic block system which is being established between St. John and Vaneeboro.



CEDAR RAPIDS CO. ANNUAL MEETING.

Montreal, Que. —The annual meeting of the Cedar Rapids Co. was held recently. The report of the president outlined the progress of construction at the Cedars and stated that the work would be pushed forward rapidly with the coming of the spring. The retiring officers and directors were re-elected.

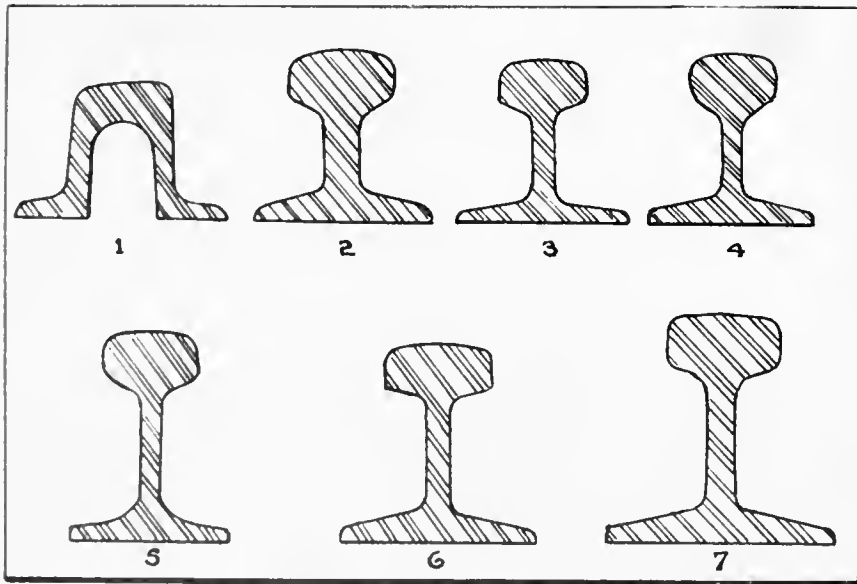

SPECIMENS OF RAILS USED AT PANAMA.

mission from 1905 to the present time, and by the Panama railroad from 1906 to 1910.

Fig. 7 is a section of the 90-pound American rail placed on curves of the Panama railroad in 1908. In 1910 open-hearth rail with 0.75 carbon was adopted as standard.

The samples, in 12-inch lengths, are mounted with the original fastenings upon a tie taken from the roadbed be-

reference to ordinary rail specifications that whereas a variation range of 15 points in carbon is reserved by the maker, specifications for electric rails are guaranteed within 5 points. Until about a year ago these electric rails were offered for testing purposes at approximately the price of open-hearth rails. More recent sales have been on the basis of about \$10.00 above that price.

REGISTERING DEPTH GAUGES.

By Chas. Hattenberger.

REGISTERING depth gauges form a very convenient means of accurately and quickly measuring the depth of holes and recesses in work. They show at a glance the amount a hole is too deep or not deep enough. They may be made of various types, depending upon the character of the work and the limit of accuracy allowable. When making gauges of this kind, it is well to make them as light

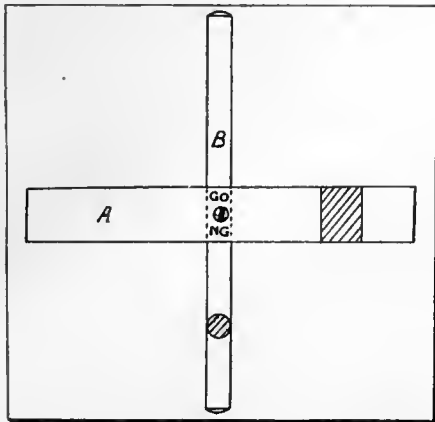

FIG. 1. REGISTERING DEPTH GAUGES.

as possible without sacrificing rigidity. The illustrations explain a few of the various types.

Fig. 1. The tool shown here is not a registering gauge, but because of its simple and cheap construction is worthy of note. It consists of the steel parallel or straight edge (A) hardened and ground, and a steel measuring rod (B), also hardened and ground, which is held by means of a small headless set screw.

The part (A) is stamped on each side of the set screw to show the long and short end of the measuring rod. It is not advisable to place this tool in the hands of semi-skilled help, unless the limit of accuracy for depth exceeds .005 inches or more.

In Fig. 2 is shown about as simple a registering gauge as could be devised. It is made up of but few movable parts and cannot get out of order through ordinary use. The frame (A) is made from tool steel, and has a ground hole passing through it. Four finger-like sections are formed by milling. The tapered portion of these fingers is used

rectangular slot cut through the wall of (A). This screw governs the movement of the rod and keeps it from falling out. A spring is placed between the part (A) and the collar (E), and serves to keep the rod always forward. The rod may be graduated into 100ths or 64ths of an inch. A slot is milled in the knurled portion of part (A) for the purpose of showing the graduations, and also furnishing a place to scribe a zero line.

A very efficient and practical gauge, shown at Fig. 3, comprises the following parts:—The frame (A) is made from machinery steel, pack-hardened,

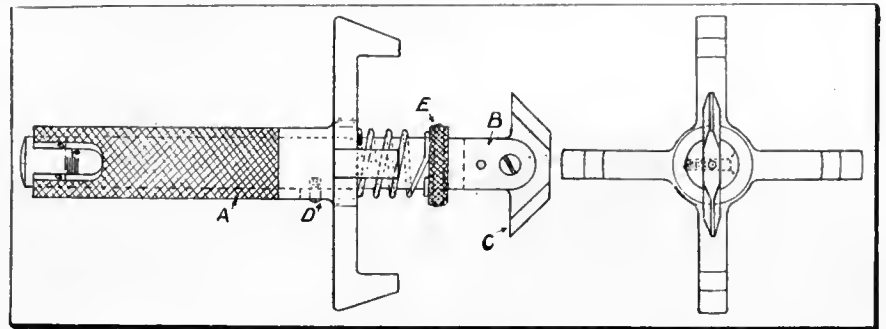

FIG. 2. REGISTERING DEPTH GAUGES.

for measuring; they are, therefore, ground to the proper size after hardening. Another part used in obtaining a proper measurement is the hardened steel piece (C). This is also ground along the tapered sides, and is fastened to the sliding rod (B) by means of a countersunk head screw and taper dowel pin. The rod should be a sliding fit in part (A). A small stud (D) is screwed into this rod and slides in a

in the form of a cross, and one of the cross-pieces has a recess milled into it to receive the pointer (D), which in turn works on a small hardened fulcrum stud, and is actuated by means of a very slight movement of the sliding plug (B). The sectional view shows a nut and also a spring; a description of these not being deemed necessary, as their utility will be seen at a glance. The cover (E) is made from sheet metal, and held by means of small screws. Part of the cover is shown cut away to show the pointer in place. Instead of having graduations, the limit of accuracy is shown inside the rectangular space marked (Go). Two hardened steel measuring points (C) are fastened by means of two screws and a taper dowel pin. A little time spent in studying the illustration will show the simplicity of construction, also the operation of this tool.

The gauge illustrated in Fig. 4 shows an instrument well adapted for fine work. The part (A) is made from machinery steel, pack-hardened. The hole passing through is ground to size as far back as the ring shown at (C). This ring is secured by means of the four screws shown. Two of these screws are pointed and act as points for the hardened steel pivot bearing (D), which is a tight fit in a hole through the pointer, (E). This pointer depends for its action upon a movement of the sliding plug (B). Motion is transmitted through the medium of a hardened steel pin (F), which bears against the projection of

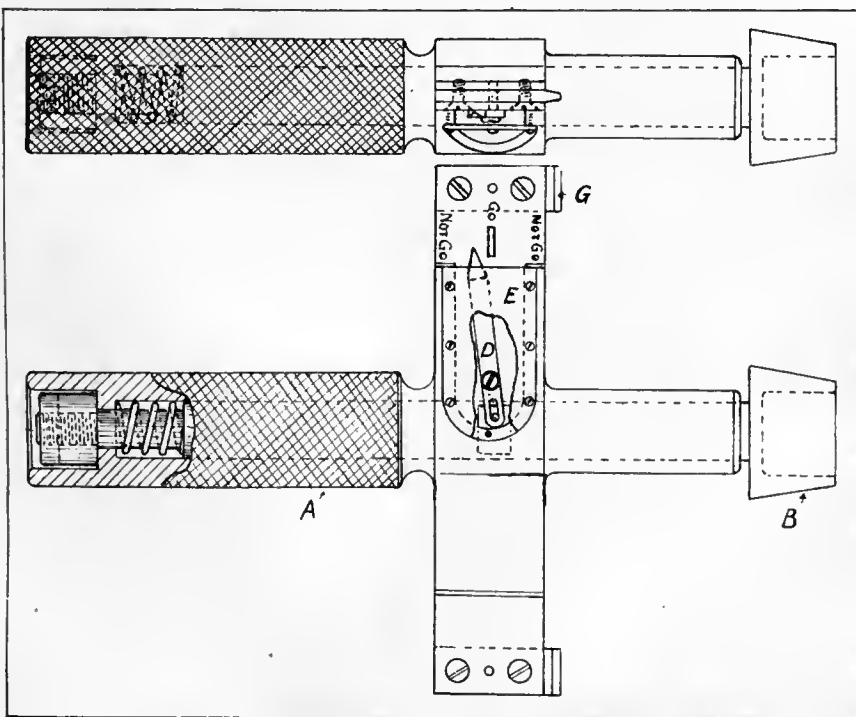

FIG. 3. REGISTERING DEPTH GAUGES.

the points. This portion of the pointer is also hardened. A small spiral spring serves to hold the pointer against the spherical face of part (F), while the large spring maintains the plug (B) in the proper position ready for use. Readings are obtained by inserting the gauge in the hole to be measured and noting the position of the pointer on the dial (H). This dial is a semi-circular piece of steel held in place by means

pressure and high pressure steam turbo-generators and mechanical stokers for firing the boilers with low-grade slack and splint coal.

The Dominion Coal Co. has recently installed a power plant at Waterford lake in which Bettington boilers, fired with pulverized low-grade coal are used to generate steam for the turbo-generators. The boilers are the first of their kind to be installed in America.

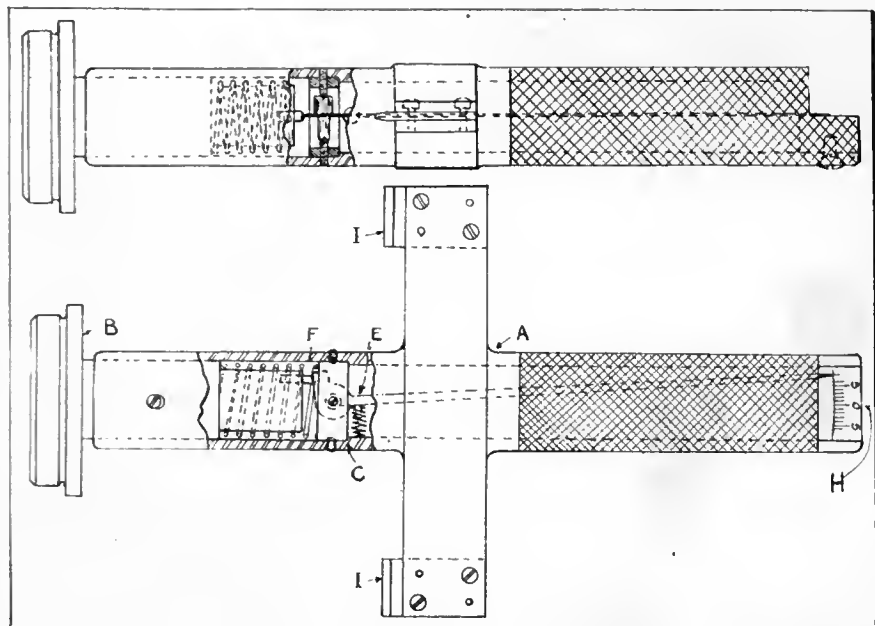

FIG. 4. REGISTERING DEPTH GAUGES.

of a screw. Two hardened steel measuring points are indicated at (I).

The gauges shown in Figs. 2, 3 and 4 are known as dead beat—that is to say, when the pressure is removed the pointer and rod resume their respective positions. I would like to see readers of Canadian Machinery who have had any experience with registering depth gauges forward a description of some for publication.

UTILIZATION OF COAL.

By W. J. D.

AMONG the economic uses of coal in Nova Scotia may be mentioned:

- (1)—The generation of power for mining purposes.
- (2)—The coking of coal in by-product coke ovens.
- (3)—The briquetting of slack coal.
- (4)—The generation of electric energy at central power plants and its transmission of the surrounding collieries. This has been developed to such an extent that some of the collieries are now operated entirely by electricity. Electric cables are carried underground by means of bore-holes and the energy is used for mine haulage and pumping purposes. These plants present many new and up-to-date features such as low-

Practically all the coke produced is made in some type of by-product oven. The Dominion Coal Co. recovers the by-products—gas, tar and ammonia. The Nova Scotia Steel and Coal Co. recovers only the gas from their coke ovens, but are considering the erection of by-product ovens. The coking of coal in by-product ovens is of importance, not only on account of the value of the by-products recovered, but also because the basis of a briquetting industry is dependent upon a supply of tar or pitch as a binder for the briquettes.

Much slack coal is now secured by mining operations in Nova Scotia, and as the higher grades of coal become less plentiful, lower-grade seams will be worked and more slack coal obtained.

There are at present, two coal briquetting plants under construction and one in operation in the above-mentioned province. The Dominion Coal Co. also has a briquetting plant under consideration, but has not yet decided where it is to be erected.

Sydney, N.S.—On March 17, the new Morgan mill was put into operation at the plant of the Dominion Iron and Steel Co.

POWER MEN HELP ONE ANOTHER.

THE first meeting of the newly formed Power House Technical Association took place recently in the offices of the City Power House, Moose Jaw, Sask. There was a very enthusiastic gathering, and an interesting discussion took place in which all present joined. It is believed that this opportunity for mutual assistance on technical subjects will be very helpful to those interested, and there is every possibility of considerable development of the scope of the Association's work. Meetings will be held every Monday evening from 8 p.m. to 10 p.m.

Another feature of the Association is the inauguration of a technical library. Membership is open to any employee of the electrical department, who will put in two or more books to the total value of \$5.00, after which he has the privilege of borrowing one. Already a large number of good books have been received, and there seems every possibility of this side of the work becoming distinctly popular. A committee, of H. Mayhew, R. Henderson and S. F. Ricketts was appointed. Rules have been drawn up, and the library established on a proper footing.

WHAT DO YOU PAY FOR WATER?

ON the average each person in Canada served by waterworks uses 113 Imperial gallons of water a day and pays \$4.12 a year for it, according to a report on the waterworks of Canada in preparation by the Commission of Conservation.

New Brunswick has the highest per capita consumption in Canada, viz: 161 gallons per head per day, while Manitoba and Saskatchewan have the lowest—46 gallons per head per day. The more general use of meters in the Western provinces reduces waste and keeps the per capita consumption down to about the same amount as in European countries. The people of Manitoba pay the highest per capita rate for their water—\$6.27 per year, while those of New Brunswick come next with a per capita cost per year of \$4.82.

The following table shows the estimated cost per 1,000 gallons, the estimated cost per capita, and the daily consumption per capita:

Province.	Estimated Cost per 1,000 gal. (cents)	Estimated Daily Cost per Capita per year (dollars)	Daily Consumption per Capita (Imp gal)
Nova Scotia	7	3.76	147
Pr. Edward Is....	16.4	2.87	48
N. Brunswick	8.2	4.82	161
Quebec	9.5	3.92	113
Ontario	9.6	4.21	120
Manitoba	20.6	3.46	46
Saskatchewan	23.0	3.86	46
Alberta	13.0	6.27	132
British Columbia .	8.2	3.44	115
Canada	10	4.12	113

SELECTED MARKET QUOTATIONS

Being a record of prices current on raw and finished material entering into the manufacture of mechanical and general engineering products.

PIG IRON.

	Per Ton.	
Foundry No. 1 and 2, f.o.b., Midland	\$19 50	\$20 50
Gray Forge, Pittsburg		16 90
Lake Superior, charcoal, Chicago		18 00
	Mont'l. Tor'to.	
Canadian f'dry, No. 1.	\$22 00	\$22 50
Canadian f'dry, No. 2.	21 50	22 00
Middlesboro, No. 3.	23 50	23 50
Summerlee, No. 2	25 00	26 50
Carron, special	25 00	
Carron, soft	25 00	
Cleveland, No. 1	24 25	25 00
Clarence, No. 3	23 75	24 50
Jarrow		25 50
Glengarnock		26 00
Radnor, charcoal iron.	30 00	34 50
Ferro Nickel pig iron (Soo)		25 00

BILLETS.

	Per Gross Ton.	
Bessemer billets, Pittsburgh	\$28 50	
Open hearth billets, Pittsburgh	29 00	
Forging billets, Pittsburgh	36 00	
Wire rods, Pittsburgh	30 00	

FINISHED IRON AND STEEL.

Per pound to large buyers:

	Cents.
Common bar iron, f.o.b., Toronto	2.10
Steel bars, f.o.b., Toronto	2.20
Common bar iron, f.o.b., Montreal	2.15
Steel bars, f.o.b., Montreal	2.25
Bessemer rails, heavy, at mill	1.25
Iron bars, Pittsburgh	1.70
Steel bars, Pittsburgh, future	1.40
Tank plates, Pittsburgh, future	1.45
Beams, Pittsburgh, future	1.45
Angles, Pittsburgh, future	1.45
Steel hoops, Pittsburgh	1.60

Toronto Warehouse f.o.b., Toronto.

	Cents.
Steel bars	2.30
Small shapes	2.45
Warehouse import, freight and duty to pay:	
Steel bars	1.95
Structural shapes	2.05
Plates	2.15

Freight, Pittsburgh to Toronto:

18 cents carload; 21 cents less carload.

BOILER PLATES.

	Mont'l. Tor'to.	
Plates, 1/4 to 1/2-in., 100 lbs.	\$2.40	\$2.40
Heads, per 100 lbs.	2.65	2.95
Tank plates, 3-16 in.	2.60	2.60
Tubes, per 100 ft., 1 inch	9.00	8.50
" " 1 1/4 in.	9.00	8.50
" " 1 1/2 "	9.00	9.00
" " 1 3/4 "	9.00	9.00
" " 2 "	9.00	9.00
" " 2 1/2 "	11.50	11.50
" " 3 "	12.00	12.00
" " 3 1/4 "	13.75	13.75
" " 3 1/2 "	15.00	15.00
" " 4 "	18.50	18.50

BOLTS, NUTS AND SCREWS.

	Per cent.	
Stove bolts	80 & 7 1/2	
Machine bolts, 3/8 and less	65 & 5	
Machine bolts, 7-16	57 1/2	
Blank bolts	57 1/2	
Bolt ends	57 1/2	
Machine screws, iron, brass	35 p c.	
Nuts, square, all sizes	4c per lb off	
Nuts, Hexagon, all sizes	4 1/4 per lb off	
Flat and round head	35 per cent.	
Fillister head	25 per cent.	
Iron rivets	60, 10, -0 off	
Wood screws, flathead, bright	85, 10, 7 1/2 p c off	
Wood screws, flathead, brass	75, 10, 7 1/2 p c off	
Wood screws, flathead bronze	70, 10, 7 1/2 p c off	

WROUGHT IRON PIPE.

The following are Toronto jobbers' discounts on pipe. (Card weight) in effect from October 11th, 1912:

	Standard	Buttweld Black Gal.	Lapweld Black Gal.
1/4 3/8 in.	63	48	
1/2 in.	68	58	
3/4 to 1 1/2	72 1/2	62 1/2	
2 in.	72 1/2	62 1/2	69 1/2 59 1/2
2 1/2 to 4 in.	72 1/2	62 1/2	71 1/2 61 1/2
4 1/2 to 6 in.			72 62
7, 8, 10 in.			66 1/2 54 1/2

X Strong P. E.

1/4, 3/8, 1/2 in.	64	54	
3/4 to 2 in.	68	58	
2 1/2 to 3 in.	68	58	
3 1/2 to 4 in.		65	55
4 1/2 to 6 in.		63 1/2	56 1/2
7 to 8 in.		56 1/2	46 1/2

XX Strong P. E.

1/2 to 2 in.	43	33	
2 1/2 to 4 in.		43	33

WROUGHT IRON PIPE.

The following are Montreal jobbers' discounts on pipe. (Card weight) in effect from October 11th, 1912:

	Standard	Buttweld Black Gal.	Lapweld Black Gal.
1/4 3/8 in.	64	49	
1/2 in.	69	59	
3/4 to 1 1/2	73 1/2	63 1/2	
2 in.	73 1/2	63 1/2	
2 1/2 to 4 in.	73 1/2	63 1/2	72 1/2 62 1/2
4 1/2 to 6 in.			74 64
7, 8, 10 in.			70 1/2 58 1/2

X Strong P. E.

1/4, 3/8 in.	64	49	
1/2 in.	65	55	
3/4 to 2 in.	69	59	
2 1/2 to 3 in.	69	59	
3 1/2 to 4 in.			66 56
4 1/2 to 6 in.			65 1/2 58 1/2
7 to 8 in.			60 1/2 50 1/2

XX Strong P. E.

1/2 to 2 in.	44	34	
2 1/2 to 4 in.			44 34

IRON PIPE FITTINGS.

Canadian malleable, 40 per cent.; cast iron, 65; standard bushings, 70; headers, 60; flanged unions, 65; malleable bushings, 65; nipples, 75; malleable, lipped unions, 65.

COKE AND COAL.

Solvay Furnace Coke	\$5.25
Solvay Foundry Coke	6.50
Connellsville Furnace Coke	5.50
Connellsville Foundry Coke	6.00
Yough, Steam Lump Coal	3.83
Penn. Steam Lump Coal	3.63
Best Slack	2.95
All net ton f.o.b. Toronto.	

OLD MATERIAL.

	Tor'to.	Mont'l.
Copper, light	\$11 00	\$10 50
Copper, crucible	14 00	13 50
Copper, unrec'bled, heavy	12 00	12 00
Copper wire, unrec'bled	12 00	12 00
No. 1 machine compos'n.	11 00	11 00
No. 1 comps'n turnings	10 00	10 00
New brass clippings	9 00	9 00
No 1 brass turnings	7 50	7 50
Heavy lead	3 25	3 00
Tea lead	2 50	2 75
Scrap zinc	3 50	3 25
Dealers' purchasing prices.		

SMOOTH STEEL WIRE.

No. 6-9 gauge, \$2.35 base; No. 10 gauge, 6c extra; No. 11 gauge, 12 extra; No. 12 gauge, 20c extra; No. 13 gauge, 30c extra; No. 14 gauge, 40c extra; No. 15 gauge, 55c extra; No. 16 gauge, 70c extra. Add 60c for coppering and \$2 for tinning.

Extra net per 100 lb.—Spring wire; bright soft drawn, 15c; charcoal (extra quality), \$1.25.

METALS.

Prices in cents per pound:

	Mont'l.	Tor'to.
Lake copper	15.75	15.75
Electrolytic copper	15.75	15.75
Spelter	6.00	6.00
Lead	4.25	4.50
Tin	49.00	49.00
Antimony	10.00	9.75
Aluminum	23.00	23.00

SHEETS.

	Mont'l.	Tor'to.
Sheets, black, No. 28....	\$2 85	\$3 00
Canada plates, ordinary,		
52 sheets	2 80	3 00
Canada plates, all bright.	3 70	4 15
Apollo brand, 10¾ oz.		
(American)	4 30	4 20
Queen's Head, 28 B.W.G..	4 50
Fleur-de-Lis, 28 B.W.G..	4 20
Gorbal's Best Best, No. 28	4 45
Viking Metal, No. 28....	4 40

NAILS AND SPIKES.

Standard steel wire nails,		
base	\$2 40	
Cut nails	\$2 60	2 65
Miscellaneous wire nails..	75 per cent.	
Pressed spikes, 5/8 diam.,		
100 lbs.	2 85	

FINE STEEL WIRE.

Discount 25 per cent. List of extras.
In 100-lb. lots: No. 17, \$5; No. 18, \$5.50; No. 19, \$6; No. 20, \$6.65; No. 21, \$7; No. 22, \$7.30; No. 23, \$7.65; No. 24,

\$8; No. 25, \$9; No. 26, \$9.50; No. 27, \$10; No. 28, \$11; No. 29, \$12; No. 30, \$13; No. 31, \$14; No. 32, \$15; No. 33, \$16; No. 34, \$17. Extras net. Tinned wire, Nos. 17-25, \$2; Nos. 26-31, \$4; Nos. 30-34, \$6. Coppered, 75c; oiling, 10c.

MISCELLANEOUS.

	Cents
Putty, 100 lb drums	\$2.70
Red dry lead, 560 lb. casks, per	
cwt.	6.25
Glue, French medal, per lb	0.10
Glue, 100 flake	0.11
White lead, ground in oil, No. 1	
pure, 100 lbs.	8.40
Tarred slaters' paper, per roll...	0.95
Motor gasoline, single bbls., gal..	24½
Benzine, per gal.	23½
Pure turpentine	64
Linseed oil, raw	58
Linseed oil, boiled	61
Plaster of Paris, per bbl.	2.10
Plumbers' Oakum, per 100 lbs..	4.25
Pure Manila rope	17

The General Market Conditions and Tendencies

This section sets forth the views and observations of men qualified to judge the outlook and with whom we are in close touch through provincial correspondents.

Montreal, Que., March 24.—Machinery dealers last week did a good average business, and conditions remain wonderfully good for this time of the year. Most of the large houses have now submitted their tenders for the C. P. R. equipment listed in **Canadian Machinery** for March 13th, and are now busy figuring on the machines required by the Canadian Car and Foundry Co. for their Fort William plant. Mill supply houses also report good business last week, several good orders for belting having been received.

Pig Iron.

Canadian pig remains steady at last week's prices, with a good amount of business offering. Old Country pig is also unchanged; but there is a certain amount of nervousness about this market, and dealers are not anxious to close large contracts just now, preferring to wait until conditions become a little more settled.

Structural Steel, Metals, Etc.

Deliveries of all forms of steel are still very hard to get, and there seems little prospect of immediate relief. Aluminum had a sharp advance during the week, and is now being quoted at 23c per pound. Present supplies of this metal are very small. Antimony is also

rising, and lead is firmer than it has been for several weeks.

Collections Unsatisfactory.

Dun's bulletin says, "General collections continue unsatisfactory, and there is a growing tendency to cull credit risks more closely than heretofore. In the money market no relief is in sight from the existing conditions, and, though the opening of navigation and heavy grain shipments may release funds to some extent, bankers show a sustained disposition to sit tight, and the checking of the speculative tendencies, which apparently permeate city and country alike, will no doubt work out to the general advantage."

Toronto, Mar. 26.—At last, the money tightness seems to be gripping the machinery market. The atmosphere feels as it did in 1907, or it is beginning to feel that way. As on the last occasion, manufacturers are too busy to promise delivery. Their factories are clogged with orders, and can only see over the heads of six and seven months. That is the irony of it. It will be remembered that this condition obtained in 1907. Money became tighter and tighter, orders suddenly dropped off and other orders were cancelled. There are no big orders for

machinery to report this week. The biggest being that placed by Billings & Spencer of St. Catharines, Ont., with one of the leading machine tool dealers. The Canadian Fairbanks-Morse Co., Ltd., have installed a 65 h.p. producer gas plant at West Lorne, Ont., for the West Lorne Electric Light Co. It will operate on the town lights and take the place of a steam engine, the gas being produced from pea coal. The newly organized Dominion Nickel Copper Co., of Sudbury, Ont., have placed a big order for electrical equipment with the Canadian General Electric Co. This includes transformers, generators and motors. Their order for other equipment has not yet been placed. They are reported to have purchased much second-hand equipment.

Pig Iron and Steel.

It was hinted to the representative in the city of a large Canadian steel concern that business was looking shaky. He laughed loudly and scornfully. "Why," he said, "our plant is working double shift. Prices are just the same, and things look fine." Another steel man said it was all very fine for Mr. A. to talk like that, but there was an unpleasant quietness in the market, which looked bad. Things were generally quiet in steel, he said. There is nothing doing in pig iron to speak of. Tubes may be expected to go higher in price within a week or so. In the United States there has been much sharper competition among manufacturers of bolts and rivets. Prices have been cut to the

extent of \$2 a ton, while this has been felt here, prices remain the same.

Metals.

There is practically no change in the metal market this week. Business is very quiet in metals as well as in old material.

St. John, N.B., March 22.—The information was given by Canadian Machinery in a special article on Maritime Province Development that the Drummond interests were seeking to establish themselves in St. John if the opportunity presented itself. Hon. Mr. Grimmer, Attorney-General for the province, while in Fredericton last week, made the definite announcement that the Canada Iron Corporation were seriously considering the removal of their foundries and blast furnaces, an immense plant, from Londonderry, Nova Scotia, to St. John, where they would be more closely associated with a big shipbuilding industry. This was spoken in connection with a resolution adopted by the Legislature, in which it was decided to lend all possible aid to the project for the establishment of a large shipbuilding plant in St. John, a project which will involve the expenditure of enormous sums of money. The Norton, Griffiths Co., who are carrying on the construction of the dry dock in this city, have made proposals with regard to the matter of the establishment of a shipbuilding plant, and have asked that the city, county and province should enter into a guaranteeing of bonds to a certain extent for a period of years. It is proposed to reclaim about 50 acres of foreshore at Courtenay Bay as the site of a shipbuilding plant, and, since it is really looked upon as certain that a plant of this nature will be erected at St. John in the near future, the news that the blast furnaces and foundries of the Canada Iron Corporation may also come here has aroused great interest.

St. John Suburban Railway Co.

Privileges have been granted to the St. John Suburban Railway Co., by which they will be allowed to construct car lines in the country districts about St. John, and requiring them to show actual construction in this connection before January 1, 1914, to the amount of \$50,000; before January 1, 1915, further construction amounting to \$50,000, and before January 1, 1916, further construction calling for an expenditure of \$100,000. Power is expected to be got from the Hydro-Electric Power Co., whose members are to a great extent interested in the formation of the new railway company to whom these rights have just been given. For

the procuring of power an expenditure of \$936,000, it is estimated, will be required at Maguadavie, and an expenditure of \$750,000 at or near Lepreaux. H. S. Ferguson, engineer, formerly in the employ of the International Waterways Commission, has been engaged to aid in the work of procuring the necessary power for the new project. The Hydro-Electric Co. will erect a large power plant, and the likelihood is that they will have a terminal in the city, to which the power will be brought from the main centre. It is the biggest scheme of its kind ever projected in New Brunswick.



A FOUNDRY KINK.

By Edwin Newsome.

OUR moulders were sometimes a little thoughtless in placing the pattern back on the match after drawing it out of the mould, the result being that it soon became rough and chipped at the parting line. To prevent this, I had

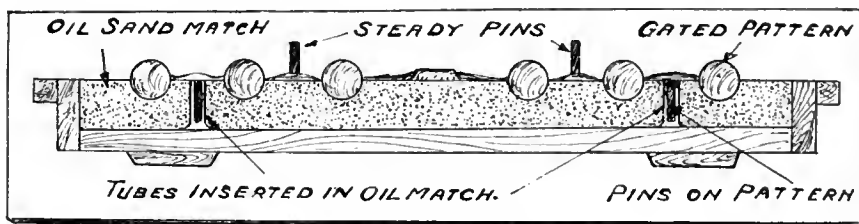

A FOUNDRY KINK.

small brass tubes placed in the oil sand match and corresponding pins fixed on the pattern, so that the latter is guided exactly into position. Our experience has been a much prolonged life of the oil sand match.



RESUSCITATION AFTER ELECTRIC SHOCK.

SOME interesting information regarding the danger of electricity is given in the Lancet by Dr. Reginald Morton, president of the Section of Electro-Therapeutics in the Royal Society of Medicine, who states that practically no shock, however severe, need necessarily prove fatal.

There are, he says, only two fundamental facts that need be impressed upon the minds of everyone. The first is that death from electrical shock is only an apparent death at first; and secondly, whatever the conditions or severity of the accident, there is practically always a time, varying from a few minutes upwards, during which it is possible to resuscitate the victim by artificial respiration if resorted to at once. So important is it to commence artificial respiration quickly that it is the first duty of the bystander to see

to this before everything else. He must not leave the victim to summon medical aid—it may be too late by the time the doctor arrives—but he should send for medical assistance if there is anyone else present.

If the victim has fallen clear of electrical contact first aid may be given at once, but if he remains in contact with the circuit, the first step is to get him free. This is dangerous to the rescuer unless care is taken, but the necessary precautions are simple enough for any voltage likely to be encountered by the public—the highest being that used for railways and tramways, about 600 volts. If, then, the victim remains in contact with the circuit, his body must not be touched by his rescuer, but the latter may pull him out of contact by hauling on the clothing, or he may take off his own coat, insert his hands in the sleeves and then handle the victim, with little or no risk to himself. Almost any article of clothing or material may be used provided it is dry and of moderate thickness.

Artificial respiration must be persevered with for at least two hours, or until the patient revives; in many cases it may be only a few minutes. After return to consciousness, complete rest is essential for a day or two, and under no circumstances must the man be allowed to return to work at once, as he may wish to do if the shock has been a light one. With the prompt application of first aid, practically every victim can be revived, and of these nearly all will make a complete and permanent recovery provided they were previously in a normal state of health.



ELECTRIC RESISTANCE WELDING.

A PAPER on "Electric Resistance Welding" was read by Mr. P. Bucher, at a recent meeting of the Manchester section of the Institution of Electrical Engineers. Although the art of welding metals was, he said, undoubtedly very old, the introduction of special apparatus and labor-saving machinery, superseding the old method, was a quite modern achievement. If the correct interpretation of welding signified the joining of two pieces together so as to form one while hot under pressure, then the only one of these new methods

which could rightly be classified under this head was the electric resistance welding. The underlying principle of resistance welding, i.e., the use of very heavy currents, made the necessary machinery heavy, cumbersome and expensive. The field was therefore not for jobbing work, where arc and hot-flame welding reigned supreme, but repetition work, where it scored immensely by virtue of its simplicity, accuracy, reliability, speed and economy.

Process Features.

The process was simple. No long tuition was required to make an unskilled laborer proficient in its use. In a good many instances his work was limited to bringing the material to the machine and starting the mechanism, in others to clamp the pieces and let the machine do the rest, but even where he had to do the clamping, the switching on and off of the current, the jumping up and afterwards the releasing of the welded piece and the swaging, he had the joint always in full view and the heat under absolute control.

It was accurate. A very high standard was attainable in this respect, for instance, the manufacture of block chain and printers' chases.

It was reliable. As the heat was generated on the piece itself, and was under perfect control, the risk of overheating or underheating, "burning" or "cold shutting," was greatly reduced; also the risk of inclusion of foreign matter, cinders, scale, flux, etc., in the joint, and the importance of this was evident when it was realized that these points were the chief causes of failure in welded joints.

It was speedy. Chain links were welded at an average rate of ten to fifteen per minute, or thirty to forty thousand per week. An average week's output of a heavy tyre welder was 525 tyres, varying in width from 2 in. to 9 in. A bank of spot-welders worked by boys on miscellaneous hollowware dealt with 120 to 180 gross of articles per machine, corresponding to about 35,000 welds per machine per week. The heat efficiency of a welder was about 75 per cent. It only used current when welding, and very little then. The above-mentioned weekly output of chain, assuming about 3 S.W. gauge, would use from 100 to 130 units. The tyre-welder referred to used according to the supply company's meter 737 units, and a spot-welder on miscellaneous hollowware used about 1 to 1.5 units for 1,000 welds.

Applications of Electric Welding.

The various applications of electric welding in commercial practice could be subdivided under the following headings:—

Plain butt-welding, or the welding

end-to-end of bars and the like of the same or approximately the same area. Butt-welding was also possible within certain limits if the two areas were dissimilar, and the object was accomplished by letting the larger bar project farther from the clamps than the smaller one in roughly the same proportion as the two

hand, some by electric, and some by gas welding, with the object of comparing the strength and fatigue properties of welds in iron and steel with the corresponding properties of the same unwelded material. The condensed result for tensile strength was expressed in percentage of the tensile strength of the unwelded material:—

Hand-welded Iron.	Hand-welded Steel.	Electric-welded Iron.	Electric-welded Steel.
Mean of 24 tests 89.3	Mean of 21 tests 81.6	Mean of 7 tests 89.2	Mean of 8 tests 93.4
In the same way for fatigue properties:—			
Hand-welded Iron.	Hand-welded Steel.	Electric-welded Iron.	Electric-welded Steel.
Mean of 21 tests 97.6	Mean of 28 tests 78.4	Mean of 5 tests 92.6	Mean of 12 tests 87.0

areas. A variation of the plain butt-welding was the angle, tee, and mitre welding, which was used on both rectangular bars and various sections of profile iron.

Spot-welding took the place of riveting in that only a small percentage of the total area in contact was welded together in circular spots. In the great majority of cases this was done one spot at a time; there were exceptions, however, where the making of two spots at a time meant a considerable saving, either obviating a change in the setting of the electrodes or the use of two machines on one job. Great care must be taken, however, in the setting of the twin electrodes so that both bear with exactly the same pressure on the work, otherwise an unequal flow of current through the two spots and with it unequal heating results. A great help in this respect was a spring-compensating device to counteract slight inequalities in the thickness of the material. A development of spot-welding was seam-welding, in which the two sheets were joined together in an uninterrupted lap weld under one or between two rotating disc electrodes.

Strength of the Weld.

The most important question in the whole business was the strength of the weld. Figures from private tests would be very unconvincing, so the author obtained permission from Dr. Stanton, of the National Physical Laboratory, to make use of figures obtained in "experiments on the strength and fatigue properties of welded joints in iron and steel," a paper read before the Institution of Civil Engineers by Messrs. Stanton and Pannell. These experiments were made on sample welds prepared by sixteen different engineering firms, according to their usual practice, some by

Strength of Spot Welds.

As proof of the strength of spot welds, the following test-certificate from Lloyd's Proving House at Netherton was quoted: "I have tested to destruction two mild steel clips electrically spot-welded, with the following results, namely:—No. 1 Clip with single butt-strap broke at 11.025 tons (clear of welded joint), being 29.01 tons per square inch of section. No. 2 Clip with double butt strap broke at 11.767 tons (clear of welded joint), being 31.01 tons per square inch of section. The weld in each case does not appear to have been disturbed." These figures proved that in the electric resistance method, the manufacturer had an entirely reliable way at his disposal to effect a weld where such was required. There were no independent figures available concerning electric welds in metals other than iron and steel. They were, however, in daily extended use in brass and copper wire mills, for joining up rods and slottings, which afterwards passed through the drawing dies.

Welding Properties of Metals.

Of the metals that could be welded by electricity, iron and mild steel came first. High carbon steel could be welded up to about 0.8 per cent. carbon, but the results were not so satisfactory as in mild steel, neither as regarded the tensile nor the torsional strength. When high carbon wire was welded, the heat of the weld was a very short one, and the bulk of the adjoining cold metal seemed to have a quenching effect on the steel, so that the wire when taken from the machine was glass-hard at the joint and snapped on the slightest effort.

To overcome this, the wire must be locally annealed—for preference in the welder itself—and this heat treatment weakened the wire for the length to

which it had been applied as compared with the rest of it. Generally speaking, the strength of welded high carbon wire was about 60 to 70 per cent. of the non-welded wire.

After iron and steel came the non-ferrous metals, chief amongst which were copper and its alloys. Pure copper welded quite satisfactorily, and so did most of the brasses unless the percentage of zinc in them was too high, when

the weld became brittle and would not draw. Nickel and most of its alloys welded very well, as did aluminum, silver, gold, platinum, and iridium.

These remarks apply, however, only to butt-welding, as only iron and mild steel lent themselves to spot-welding in a satisfactory manner. Brass and aluminum could be spot-welded, but the process was not very reliable nor economical on account of the heavy current required.

preferred, and where possible the designs are modified, so that these machines may be used. Then we miss the ear-splitting screech of the slow-moving belt and rattle of gears of the old-fashioned planing machine, and instead we find the double-belt machine, running quietly and smoothly and reversing the table promptly without jar or rattle, and also the machine fitted with its own reversing motor and variable-speed switch gear, so that the table can run at the speed most suitable for the class of work it is engaged on.

A part of the shop is divided off for a group of grinding machines, and here we find a striking change from the old order of things. The lathe of to-day is rightly considered as a roughing tool only, and the grinding machine a refining tool. The aim of the modern engineer is to obtain the best work in the shortest possible time and at the lowest labor cost. In the case of cylindrical work, this ideal is reached by the combination of very rough turning and finish grinding. The grinding machine has been found to be indispensable for the production of interchangeable work, and for the accurate finishing of hardened parts, whether round or flat. We find that wet grinding produces better results than dry.

System.

Upon looking more carefully into the details of organization, we find systematic order in everything. Appliances and jigs there are in plenty, shaped to hold the parts in true position while undergoing some machining operation or to guide the tools aright. Each has its distinctive mark, denoting its use and store location. After use it is returned to its position in the stores, where it may readily be found again. Thus the old adage is carried out—"A place for everything, and everything in its place."

The Drawing Office.

Upon visiting the drawing office we see that the same systematic order prevails, all drawings are stored away and a card index kept, by the aid of which any one can be instantly found. In older shops it was usual to leave the foreman to decide how a particular piece of work should be machined, but now there are draughtsmen and special men set apart who decide such things. From the tool drawing-office, written instructions are issued, which state the machine for the work, the tools to be used, and the time allowed for doing the job.

Another matter we note of great importance: There is an inspector provided with a full equipment of gauges, whose duty it is to gauge all finished work produced, and to see that in all dimensions it is within the allowed error limits of size. From a recent issue of the "Machine Tool Engineer."

A Contrast in Machine Shops and their Equipment

By Raynor

The last century has been remarkable for being a distinctly mechanical era. At the beginning, the machine shop scarcely existed, except in the most primitive form, and machinery of any but the crudest types was practically unknown.

THE building of machinery requires machine tools and the machine shop, and the engineering trade has so developed that it has become an important factor in every industry, directly or indirectly influencing every other trade and profession.

The Old Order and the New.

Those who have been sufficiently long in the world have noticed from time to time how certain manufacturers with honored and famous names have found themselves unable to keep their heads above water, and have gone out of business. In most cases, this has been the result of working on unprogressive lines and of failing to take advantage of the latest machinery and labor-saving devices. The importance of up-to-date methods of doing work in general needs no emphasis.

Automatic Production.

Whoever has studied the evolution of any highly developed manufacture will have observed that progress in the past has always been in the direction of making productive processes more and more automatic and of obtaining a continually increasing output from each workman without increasing the manual effort exerted by him. With this development there has gone hand in hand an improvement in the construction of the machine shop and in the methods of driving. What a difference we find in the various shops!

The Old-Time Shop.

Upon entering the old-time shop it was like walking into a place of gloom, thick dirt on the windows made the light dim, the shop contents were scattered about in great confusion, turnings and machine swarf lay thick on the floor, scrap castings were rusting in heaps—everything seemed to move at a pace set by a wheezy old steam engine which worked in one corner. The men were mostly old men who had matured in the

place. Neither milling machine nor turret lathe had a place in the shop, the machinery of which reminded one of a second-hand dealer's store.

No one seemed to know what was meant by a jig or a former, and their system of keeping tools was to pile them under the machines or benches, and any man requiring a tool sorted it for himself. Tons of lathe and machine tools lay scattered about haphazard. Here was a shop that had once built a reputation for a specialty and existed on it still, yet the whole atmosphere of the place was represented by the one word, "decay."

The Up-to-Date Shop.

Upon entering an up-to-date shop, the first impression one feels is very different. There is an air of freshness and briskness about the place, yet no unnecessary bustle and hurry. Everybody seems to be infected with the same spirit, and even a visitor feels that he must not dawdle around. Machinery and floors are kept clean, the light is good, the temperature comfortable, and the place well ventilated. The men are of all ages, and mostly look happy. The machines are arranged in orderly systematic groups, each group obtaining its power from a neat little motor, which whisks the shafting around at a smart pace. In one corner, which at first seems somewhat deserted in appearance, we find a group of automatic screw machines, which quietly, and with regular rhythm earnestly intent upon their business, drop out a regular stream of finished screws and simple parts.

Turret lathes, small and large, are there at work on both bars and castings. Boring and turning mills we see, and gang drills. Feeling to miss old friends, we ask where are the slotting and shaping machines, and hear that there are one or two about the place, but their use is not so general as it once was. The continuous cut of the miller and profiler is

The MacLean Pub. Co., Ltd.

(ESTABLISHED 1888.)

JOHN BAYNE MACLEAN - - - - - President
H. T. HUNTER - - - - - General Manager
PUBLISHERS OF

CANADIAN MACHINERY AND MANUFACTURING NEWS

A weekly newspaper devoted to machinery and manufacturing interests, mechanical and electrical trades, the foundry, technical progress, construction and improvement.

H. V. TYRRELL - - - - - Business Manager

EDITORIAL STAFF:

PETER BAIN, M.E., J. H. WILLIAMS, C. W. BYERS

OFFICES:

CANADA	GREAT BRITAIN
Montreal , Rooms 701-702 Eastern Townships Bank Bldg.	London , 88 Fleet Street, E.C. Phone Central 12960 E. J. Dodd
Toronto , 143-149 University Ave., Phone Main 7324	UNITED STATES
Winnipeg , 34 Royal Bank Bldg., Phone Garry 2313	New York , R. B. Huestis, 115 Broadway, New York, N. Y., Phone 2209 Rector
Vancouver , H. Hodgson, 2640 Third Ave. West.	Chicago , A. H. Byrne Room 607, Marquette Bldg. 140 S. Dearborn St., Chicago

CABLE ADDRESS:

Macpubco, Toronto. Atabek, London, Eng.

SUBSCRIPTION RATE:

Canada, \$2.00; United States, \$2.50; Great Britain, Australia and other colonies, 8s. 6d. per year; other countries, \$3.00. Advertising rates on request.

Subscribers who are not receiving their paper regularly will confer a favor on us by letting us know. We should be notified at once of any change in address, giving both old and new.

Vol. IX. MARCH 27, 1913 No. 10

PRINCIPAL CONTENTS.

The Present State of the Art of Industrial Management.....	311-315
Recent Judicial Decisions	315
General	315
New Inventions...Manganese Steel Dredge Buckets.	
Canadian Pacific Railway Co. Elevator, Port McNicholl, Ont.	316-317
Art of Industrial Management	317
Judlog of Results in Technical Journal Advertising.....	318-320
General	320
Workmen's Compensation...Lubrication of Machine Tool Bearing Surfaces...Trade Between Canada and Britain.	
Machine Shop Methods and Devices.....	321-322
High Speed Steel Economy...Improved Steel Coupling...A Drill Jig...Boring a 30-inch Sluice Valve for Saskatoon Waterworks...Valves in Pipe Lines.	
Developments in Machinery	323-325
Silent Chain Transmission of Large Powers...Six-inch Face or Barrel Cam Cutting Fixture...Four-Plane Shell Drilling Machine...The R. McDougall Co., Galt, Ont.	
General	326-328
Rails Used at Panama...Electric Steel Rails...Testing Locomotives in the Erecting Shop...C.P.R. and St. John, N.B....Cedar Rapids Co. Annual Meeting...Registering Depth Gauges...Utilization of Coal...Lower Men Help One Another...What Do You Pay for Water?	
Selected Market Quotations	329-330
The General Market Conditions and Tendencies	330-331
General	331-333
A Foundry Kink...Resuscitation After Electric Shock...Electric Resistance Welding.	
Editorial	331
Industrial and Construction News	333-338
Engineering ... Electrical ... General Industrial... Railways and Bridges ... Building Notes ... Wood-Working ... Tenders ... Contracts Awarded... Miscellaneous...Trade Gossip...Personal...Obituary.	

CANADA AND EMERGENCIES.

WHETHER we be Tories or Liberals, Imperialists or Nationalists, Canadian-born or otherwise, we are grieved to be told by Mr. Winston Churchill, First Lord of the British Admiralty, that Canada is unable to build and man battleships in sufficient time to meet the emergency. After reading Mr. Churchill's letter to the Premier, we are inclined to cry out, that 'nothing is impossible

with Canadians, for did they not, thirty years ago, build the greatest railway in the world, and are they not to-day building equipment for this and two others?' We are compelled, however to admit the accuracy of Mr. Churchill's statement. The emergency, which is said to exist, creates a situation requiring prompt action if Great Britain is effectually to compete with Germany.

Without this emergency, the assertion of the First Lord would be ridiculous, being analogous to a declaration that farmer Jones cannot supply eggs for the Sunday school picnic, because he has no hens. Cannot Jones buy some hens? Yes, but he cannot force them to lay, and the picnic is to-day. It occurs to one after a little thought, that Jones may, after all, buy the hens and supply the eggs for next year's picnic.

So it is with Canada. Let her meet this emergency with what come readiest to hand, and then prepare to meet the next one herself. It is childish to suppose that no other call will be made on this country for battleships. The next battleships should be built here, and preparations made now. Preparations are, of course, being made. Shipbuilding plants are being projected on a large scale both in the East and West, and every support should be given to them.

We are told by Mr. Churchill that "for the manufacture of armor plates, large steel furnaces, heavy rolling mills, etc., capable of dealing with weights of 150 tons at a time, have to be provided, besides which the special treatment to obtain the correct quality of plates requires special experts who have been brought up to nothing else. Such men could not be obtained in Canada."

Such men can be obtained in Canada, and Canada is not limited to her own population. If she can bring experts from Great Britain and the United States to plan her waterworks systems, she can also obtain shipbuilding experts from abroad. Mr. Churchill loses sight of the emergency in his calculations. In every one of his statements regarding Canada's inability, the words 'under the circumstances' should be appended, or the statement sounds untrue and ridiculous.

The First Lord of the Admiralty lays much stress on the fact that the cost of doing this work here will be about twice what it would be in Great Britain, and that the officers and crews of the Rainbow and the Niobe receive two-thirds more wages than those in the Imperial navy. Exactly. The men sweeping the streets of Toronto receive two-thirds more wages than the men sweeping the streets of London, England, yet nobody has ever considered it an outrage. If the United States had taken wages into consideration, she would not have had her shipyards and arsenals to-day, but would be ordering her battleships in Great Britain, where they are cheap.

Canada is reminded of certain South American States who bought warships, and by non-attention, allowed them to scrap. These Southern States are not autonomous in the sense Canada is. Their warships were merely immense toys, for which they had no use, for once they put them to work, the Monroe Doctrine stepped in, and this made them useless.

Canada must, first of all, put herself in the right frame of mind. Her initial attempt to equip a navy has been a joke, which nobody laughs at, because of its realized seriousness. The naval profession in this Dominion must be lifted to a standard equal to that of Great Britain. The highest positions must be available to the humblest, so that it will be as honorable and lucrative to be a captain in the Canadian navy as to be chief engineer of a railway division. When this consummation is attained, Canada will be more of a nation, and emergencies will not humiliate her.

INDUSTRIAL ^A_N^D CONSTRUCTION NEWS

Establishment or Enlargement of Factories, Mills, Power Plants, Etc.; Construction of Railways, Bridges, Etc.; Municipal Undertakings; Mining News.

Engineering

Edmonton, Alta.—The Edmonton Plating Company have started operations at 786 Jasper Avenue East.

St. John, N.B.—The Canadian Iron Corporation will probably move their plant from Londonderry, N.S., to St. John.

Port Arthur, Ont.—Plans are being prepared for a new wire goods factory. Mr. Brutinel, of this city, is behind the scheme.

St. Boniface, Man.—The William Galloway Co., Waterloo, Iowa, U.S.A., have purchased a site and will erect an agricultural implement plant here.

Sarnia, Ont.—The casting room of the Goodison Thresher Works suffered \$3,000 damage by fire March 20. John Goodison, manager.

St. Thomas, Ont.—It is announced that the Michigan Central Railway will spend \$150,000 this year in erecting a new machine shop and power house.

Edmonton, Alta.—Dealers in farm machinery threaten to leave the province if the Government pass the farm machinery legislation, which seems likely.

Fredericton, N.B.—The Provincial Legislature has adopted the principle of financial aid to the Norton Griffiths Co. in establishing a shipbuilding plant at St. John.

Windsor, Ont.—The Vincent Steel Process Company have closed a deal to purchase three acres of land south of Hanna Avenue and east of McDougall Street, and will erect a plant this year.

Bridgeburg, Ont.—The Chicago Bridge and Iron Works, makers of steel towers, tanks and gas holders, have purchased seven acres of land, and will erect a plant to employ 100 men.

Toronto, Ont.—The Oxy-Acetylene Company, a French firm, for cutting and welding steel, will build a factory, with 200 ft. frontage, in the west end to employ 50 hands.

Victoria, B.C.—The supply of water from the Esquimalt Waterworks is to be trebled by increasing the size of pipe from 12-in. to 18-in., so as to give 6,000,000 gallons daily.

Londonderry, N.S.—The Canada Iron Corporation will remove their pipe

works to St. John or Bathurst, N.B., and turn their rolling mill machinery over to the Rhodes Curry Company.

Windsor, Ont.—The Swedish Crucible Steel Co. has closed a deal for a site of an acre and a half at Hanna Avenue and McDougall Street, and will proceed at once with the erection of a building.

Seaforth, Ont.—The Canada Furniture Manufacturers, Canada Flax Mills, R. Ball Engine and Thresher Co., Canada Cereal and Milling Co. all suffered loss to their plants in last week's storm.

Kingston, Ont.—The Dominion Government has given the contract for fifteen locomotives to the Canada Locomotive Co. of Kingston; ten are of the consolidated type, and five are switch engines.

Toronto, Ont.—The Gurney Foundry Company are building a one-storey brick and steel core shop at a cost of \$40,000, and a two-storey cupola building of brick and steel on Cawthra street, at a cost of \$4,000.

Halifax, N.S.—The Davison Parker Co. have moved their mills from Longard Road to the premises which were formerly occupied by the Nova Scotia Foundry Company. All the machinery has been installed.

Port Stanley, Ont.—Messrs. T. Hall & Co., Talbot Street, St. Thomas, will erect a frame building for a machine shop with cement floor, 30 x 60 ft. New machinery will be installed for repair work, especially marine.

North Bay, Ont.—Machine shops for the C.P.R. costing \$250,000, will be erected here, and will employ from 100 to 200 men. The T. & N.O. Rly. is also reported to be planning new shops for this summer, costing \$350,000.

Brantford, Ont.—The Waterous Engine Works has under consideration the erection of a large addition to its plant this year. Mr. D. J. Waterous, states that no plans have been prepared yet. A building 200x250 feet will be added to the present plant.

Montreal, Que.—The Hall Switch & Signal Co., 50 Church Street, New York, who are doing extensive work for the C.P.R., are negotiating for the construction of a plant somewhere in the Dominion. Montreal or Peterborough it is thought will be selected.

St. John's, Nfld.—The extensive machine shops of the Reid-Newfoundland Co. are reported to have been destroyed Mar. 14 by a disastrous fire. It is understood that the loss can be counted in the hundreds of thousands, as the shops were extensive and full of up-to-date machinery.

Quebec, Que.—At a general meeting of the Eastern Canada Steel Co., held here on Thursday, March 13, a number of important changes were made in the Board. The new officers are as follows: President—L. H. Gandy; Vice-President—J. T. Donohue; Secretary-Treasurer—J. W. C. Hall.

Electrical

Harriston, Ont.—A new electric lighting plant has been installed by the city.

Brantford, Ont.—The Hydro power for the pumping station is costing \$23.65 per h.p. per year.

Hamilton, Ont.—The Hydro-Electric Commission will reduce the price of power here to \$15 per h.p. after Oct. 1.

Montreal, Que.—The Bell Telephone Co. will lay underground conduits on fifty main streets at a cost of \$200,000.

Lethbridge, Alta.—City Engineer Blanchard is working on plans for a new filtration plant. It will be a duplicate of that in Saskatoon, and will cost \$75,000. Building will start this spring.

MACHINERY TRADE ACTIVE.

Mercantile agencies report that in all branches of machinery manufacturing the volume of business transacted has been exceptionally large, and that the outlook for the coming summer is most satisfactory. Trade in wood working and iron machinery is especially heavy, and there has been no need during the past winter to curtail operations to any extent. With the opening of navigation and the resumption of activity in connection with railway construction the capacity of many of the plants, it is said, may be exceeded.

London, Ont.—The London Electric Company will install two turbine steam engines of 500 h.p. each, and much electrical machinery.

Souris, Man.—The Council will consider a by-law to provide electric light and power. Cluster lights will be used, and pumps and motors purchased.

Toronto, Ont.—The city will install a turbo-electric generating unit of almost 7,000 h.p. at John Street pumping station as an auxiliary. The outfit will cost \$95,000.

West Hamilton, Ont.—An electric lighting system for Ontario Hydro-Electric Power Commission will be installed. Chairman of Local Commission, R. W. Karch, Dundas. Will require poles, insulators, 600 ft. steel guy wire, galvanized, 1,200 carriage bolts, cross arms, lightning arresters, 22,800 ft. copper wire, 2.5 kw. transformers, power, 1-5 kw. transformer, lighting, 3-10 kw. transformers, lighting, 7,300 lbs., copper wire for streets.

Toronto, Ont.—Announcement has been made by Hon. Adam Beck that the Hydro-Electric Commission will at once advertise for tenders for the construction of the transmission line from Dundas to Windsor. The cost of the extension will be several million dollars. It was announced also that the commission will call tenders for the material for the construction of lines from Cannington to Beaverton, from Berlin to Elmira, from Clinton to Goderich and from Brantford to Paris. This material it is expected, will cost two million dollars.

Berlin, Ont.—The Light Commission has received an order for 500 horse-power of Hydro energy from the Dominion Tire Co., to be delivered by September 1st of this year. In addition to this large order, 800 horse-power will be added to the demand on the plant by local industries and the waterworks system, making the total increase of load this year, 1,300 horsepower. It will be necessary for the Hydro Commission to increase the capacity of the local transformer station at an early date to supply the great demand for Hydro power in this industrial centre, and the Light Commissioners will wait on Hon. Adam Beck this week to secure an addition to the station as soon as possible.

General Industrial

Brampton, Ont.—W. G. Downing, Ltd., will establish a shoe factory here if the town loans them \$15,000 for ten years.

Winnipeg, Man.—Fire in the Canadian Oil Company's factory at Elm-

wood did \$15,000 damage, covered by insurance.

Bridgeburg, Ont.—Dr. A. S. Ramage, Richmond Ave., Buffalo, has rented a building here in which a new paint will be manufactured.

Cornwall, Ont.—The Ives Modern Bedstead Co., contemplates the erection of a new factory for manufacturing bed springs and mattresses.

Transcona, Man.—Arthur W. Humber & Co. will build a plant here, costing \$50,000. Plans are complete, and building will commence at once.

Burnaby, B.C.—The Kingsway Cement Construction Co. have ordered additional machinery for their plant. A. J. Mendum and H. Taylor are interested.

Halifax, N.S.—A sulphite pulp mill will be erected at Bear River, N.S., where there is a water power of 4,000 h.p. W. G. Clarke, Bear River, is interested.

Prince Albert, Sask.—It is stated that Felix Frank, will erect a factory to produce nitrogenous fertilizers and other chemical substances, which will employ 2,000 workmen.

Russell, Ont.—A new company has been organized, and will erect a plant for the manufacture of sewer pipes, fire-proof material, etc. adjoining the plant of the Russell Shale Brick Co.

Chilliwack, B.C.—The Canadian Safety Containers Ltd., plan to erect a plant at Chilliwack for the manufacture of the Hercules safety containers. Estimated cost, \$15,000. C. Snokow is the secretary.

Beamsville, Ont.—The Reid and Pigott Co. will establish a branch basket factory here. They have purchased the Dominion Cannery factory which they will enlarge, and install new machinery. They will employ 50 men.

Medicine Hat, Alta.—Warren Overpack has purchased the Purmal Brick Company's plant, and will increase its capacity by extending and installing new machinery. When completed it will have a capacity of 100,000 bricks per day.

South Woodsless, Ont.—Thomas P. Hooker plans the erection of a flour mill here, of two stories, white brick construction, with concrete and stone foundation. The equipment required includes gasoline engine, grain cleaner, shellers and choppers.

Glace Bay, N.S.—The pumping of the Emery slope at the Dominion mine is completed, and the work of installing the

machinery and equipment in what will be known as Dominion No. 11, is under way. It is expected the new mine will be producing coal about June.

Railways - Bridges

Toronto, Ont.—The Board of Control have decided to build the Bloor Street Viaduct of steel.

Edmonton, Alta.—The Lethbridge Radial Tramway Co. will construct a line from Lethbridge to Raymond and Stafford.

Toronto, Ont.—The Temiskaming and Northern Ontario Railway Commission will start construction work on the Elk City-Gowganda branch this summer.

Fredericton, N.B.—The Suburban Railway Co. which proposes to build and operate car lines in St. John suburbs, has been granted a charter, American and St. John men are interested.

Regina, Sask.—The city will this year spend over \$140,000 for street railway work, and the United States Steel Products Co. has been awarded a contract for supplies amounting to \$120,000, the balance of the amount for other supplies being divided among several firms whose tenders were very close.

St. John, N.B.—The Canadian Pacific Railway is said to be preparing plans for the construction of a new bridge across the Falls at St. John to replace the present cantilever bridge. The contract for the Provincial Government's spandrel arch bridge at the same place has already been let to the Dominion Bridge Co., Montreal, so that it is quite possible that two bridges will be in course of erection simultaneously at this important spot.

Building Notes

Woodstock, Ont.—It is proposed to build a new city hall if the ratepayers will pass the by-law.

Guelph, Ont.—The ratepayers will vote on a proposition to build a hospital at a cost of \$30,000.

Regina, Sask.—The Grand Trunk Pacific Railway will erect a nine-storey hotel, costing \$1,000,000 here.

St. Thomas, Ont.—The new building being erected by the Canada Iron Corporation was blown down in last week's storm.

Toronto, Ont.—J. & A. Aziz will erect a \$25,000 five-storey brick warehouse on the north side of Wellington Street, near Simeco.

John B. Smith & Sons, Ltd.

Manufacturers of Lumber, Lath, Shingles,
Doors, Sash, Blinds, Etc.

Toronto, March 6, 1913

General Fire Equipment Co.,
72 Queen St. East,
City.

Dear Sirs:—

We have your favor of the 3rd Inst., and are pleased to tell you that the fire in our shavings vault amounted to almost nothing, so far as damage was concerned any more than we had to empty the shavings on account of being wet through, two of the sprinkler heads having opened and making the fire loss almost nil as stated above.

Yours truly,

John B. Smith & Sons, Ltd.,
W. J. Smith.

P.S.—This is the 3rd fire put out by the sprinklers, and we did not make claim on Insurance in any of these cases.—
W.J.S.

Three Fires!
Fire Loss Almost Nil
No Claim on Insurance

The letter printed herewith gives one firm's experience with our Automatic Sprinklers.

Three fires snuffed out in a jiffy. No damage to speak of—no claim on insurance companies. No shut downs. And these three fires started in places where big conflagrations might have developed in an amazingly short time.



Manufacturers' Automatic Sprinklers

are absolutely sure. They get right at the heart of a fire as soon as it starts. That's why the insurance is so low on any building they protect. The insurance premiums they save will pay for their installation in from four to five years.

The General Fire Equipment Co., Limited., 72 Queen Street East, Toronto

CAST STEEL CASTINGS

Heavy Castings Up To 20 Tons
Locomotives, Engine Frames, Wheel Centres
and Machinery Castings Our Specialty.

Stock Process Steel for Automobile and Light Castings of all Descriptions.

Prompt Deliveries.

(Annual Capacity, 12,000 tons.)

Let us figure on your requirements.

The Dominion Steel Castings Company, Limited
HAMILTON, ONTARIO

Goderich, Ont.—Tenders are being called for a \$20,000 addition to the Collegiate Institute, with new system of heating and plumbing throughout.

Toronto, Ont.—The Paterson Manufacturing Company will erect a storage warehouse, costing \$6,000, on the east side of Berkeley Street, near the Esplanade.

Toronto, Ont.—Collet & Sproule, Limited, makers of paper boxes, will build a four-storey warehouse, costing \$30,000, on the east side of Portland Street, near Adelaide.

Winnipeg, Man.—The Isaac Brock School will be the largest in the city. J. B. Mitchell, architect; approximate cost, \$225,000. Dimensions, 195 x 160 ft.; 32 class rooms, and seating capacity for 1,200.

Winnipeg, Man.—An engineering building will be constructed in connection with the Manitoba Agricultural College, St. Vital, to be ready December 31. Tenders are being called for now by the provincial architect.

Toronto, Ont.—An eight-storey apartment house, containing 600 rooms, is to be erected on the south side of Wellesley Street, from Shelbourne to Bleecker Street, at a cost of \$500,000. The builders are Messrs. Deeth & Sons.

Wood-Working

Mission City, B.C.—A. S. Rankin and J. W. Schneider, have acquired a site and will begin the erection of a box factory.

Dryden, Ont.—The first pulp was made at the \$1,000,000 plant of the Dryden Timber and Power Co. last week.

Toronto, Ont.—Fire damaged the carriage factory of Robert Elder, on Soho Street, last Saturday, to the extent of \$3,000.

Fort George, B.C.—The Cariboo Timber Co. are arranging for the erection of a sawmill. The daily capacity will be 25,000 feet.

Fort George, B.C.—The Cariboo Timber Co. will erect a sawmill with a daily capacity of 25,000 ft., as soon as navigation opens.

Twin Lake, Ont.—Waugh Bros. have moved their sawmill to Harley. John Atchison and H. Hammond will build a saw mill.

Delhi, Ont.—Fire on Monday, March 17, destroyed Quance Bros.' saw mill, and also a large quantity of lumber in the yards. The loss was about \$12,000, partly covered by insurance.

Roxton Falls, Que.—Plans will be prepared for a new furniture factory for the Labriehere Co., Ltd., Roxton Falls, Que. Machinery will be required.

Montreal, Que.—The J. & N. Duncan Co., 1833 Ontario St., will build a new planing mill for which equipment will be required. The building will be two stories, 40 x 80 ft., of brick construction with concrete foundation. It will cost \$5,000.

Black's Harbor, N.B.—Connor Bros., Limited, are considering the erection of a mill. Their intention is to erect a plant operated by a 100 h.p. steam unit, with rotary planer, box making, shingle and woodworking machinery. Equipment is required.

Ottawa, Ont.—Damage to the extent of \$70,000 was caused by fire in the woodworking plant of the McAuliffe-Davis Lumber Co., Ltd., on Saturday, March 8. The building was completely gutted and the flames destroyed much valuable machinery. The loss to the McAuliffe-Davis Company is something over \$60,000, which is covered by insurance.

Stratford, Ont.—The ratepayers passed the by-law to guarantee the bonds of The Farquharson-Gifford Co., for \$20,000 and grant a free site. In consideration of this, the company agrees to erect a factory 150 feet by 60 feet, four storeys high, or its equivalent in size of such dimensions. The plant will be equipped with machinery, and not less than \$30,000 will be expended. This company will manufacture upholstered furniture.

Byng Inlet, Ont.—Graves, Bigwood & Co., Toronto, have decided to erect a modern and thoroughly up-to-date mill here, to take the place of the one which was destroyed by fire last year. The foundations for the new mill are already in and contracts for the erection will be let immediately. The plant will have a capacity of about 175,000 feet per day, and will be equipped with modern machinery and all the latest labor-saving appliances.

Marine

New Westminster, B.C.—The C. N. R. will build two large ferry terminal docks at Woodward Slough, on Lulu Island, for freight and passenger service.

Coquitlam, B.C.—The first keel laid by the Coquitlam Shipbuilding Co. was put down last week on the Pitt River. The vessel is an oil-burning lumber carrying steamer, 236 ft. over all, 187 ft. keel, and 43 ft. beam. All the yards on the Fraser River are busy.

Fort William, Ont.—Two of the 48 vessels recently put up for sale by the insolvent Gilchrist Steamship Company, were bought by the Merchants Mutual Lane. They are of the ordinary package freighter size.

Quebec, Que.—The city has awarded a contract to the Seagrave Co., Walkerville, Ont., for four motor tractors at \$7,200 each to haul the Waterous fire engine and aerial ladders. An aerial ladder at \$6,650 was bought from the same firm.

Tenders

Toronto, Ont.—Tenders will be received by the Chairman of the Board of Control, up to April 1st, for Concrete Piers, Abutments and Floor for St. Clair Avenue Bridge, at location east of Bathurst Street. H. C. Hoeken, Mayor.

Regina, Sask.—Tenders will be received up to April 30 for a 1200 k.w. Synchronous Motor Generator or motor converter set, with a.c. motor and generator panel and equalizing pedestal for control of d.c. generator. E.W. Bull, super. of light and power.

Vernon, B.C.—Tenders will be received up to April 11th, by D. G. Tate, City Clerk, Vernon, B.C., for the following equipment: Supply and installation of one 500 B.H.P. Diesel Engine. Supply and installation of one 375 kw. 2300 volt, three phase, sixty cycle, generator with direct connected exciter. Supply of one ten-ton travelling crane. Mather, Yuill & Company, Ltd., Consulting Engineers, Vancouver, B.C.

St. John, N. B.—Tenders are now being received by R. S. Kent, consulting engineer, Mechanics Bank Bldg., Brooklyn, N.Y., for furnishing 36 cast-iron filters, 16 ft. in diameter and 20 ft. high, and also cast-iron tanks. These will be used in the plant now being constructed in St. Johns, N. B., by the Atlantic Sugar Refineries, Ltd., of Montreal. Plans and specifications for the cast-iron work may be secured at the office of the consulting engineer.

Windsor, Ont.—Tenders addressed to J. F. Smyth, Chairman, Water Commissioners, will be received up to Tuesday, March 25th, for 400 tons more or less of cast iron water pipe, size from 6-in. to 12-in.; also specials consisting of crosses, tees and bends, according to standard specifications of the Canadian Society of Civil Engineers. Delivery of 50 tons to begin fifteen days after notification of acceptance of tender, and balance continued as required. Delivery to be f.o.b. cars Windsor, Ont. W. A. Hanrahan, secretary.

BOILERS

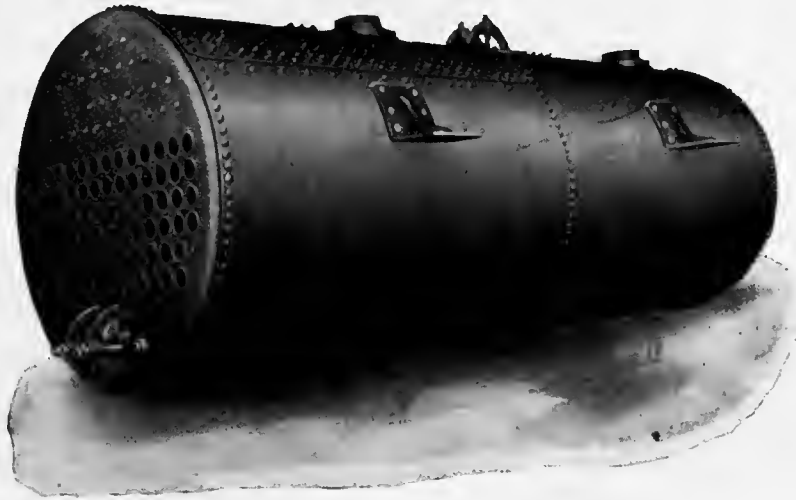

“Inglis” Boilers—“A Product Without a Peer”

Every boiler before it leaves our shops is subjected to the most rigid inspection, in fact every feature is most carefully watched in the manufacture, our constant aim being to make “INGLIS” Boilers safe, durable and economical.

Write Us For Prices.

THE JOHN INGLIS COMPANY, Ltd.

Engineers and Boilermakers

14 Strachan Ave.

TORONTO, CAN.

Contracts Awarded

Toronto, Ont.—The contract for constructing the civic abattoir was let to Wickett Bros., Toronto, and W. R. Perrin, Chicago, is the architect.

Montreal, Que.—The contract for furnishing and laying a 36in. steel main across Lachine Canal, at Wellington Street, has been let to Laurier & Leitch, 5 Beaver Hall Square.

Winnipeg, Man.—The Board of Control have awarded the contract for a 3,000 k.w. transformer to the Canadian Westinghouse Co., Hamilton, Ont.

Longueuil, Que.—A filtration plant, to cost \$10,000, with a capacity of one million gallons, will be built. The contract has been awarded to The John McDougal Co., of Montreal.

Vancouver, B.C.—The Worswick Paving Co. of this city, has obtained a \$300,000 paving contract from the City of Edmonton, the yardage being slightly over 100,000 square yards.

Quebec, Que.—Villeneuve, Bosse, Banks & Boivin, of this city, have been awarded the contract for the enlargement of the Quebec Post Office, involving an expenditure of \$400,000.

Vancouver, B.C.—Messrs. Westinghouse, Kerr & Co. have secured the contract to build a new structure for the C. P. R. dining and sleeping car departments at a cost of \$3,000.

Vancouver, B.C.—The Canadian Ferro Concrete Co., of Cordova Street, have been awarded a contract for a 15-storey building by Russell, Babcock & Rice, at a cost of \$800,000. Work will commence April 1.

Vancouver, B.C.—The contract for steel pipe, in connection with the new power station at Kamloops, B.C., has been awarded to The Crane Co., and the contract for wood stave pipe to the Pacific Coast Pipe Co.

Port William, Ont.—The Canadian Stewart Co. of this city, have secured the contract for building a 3,000,000 bushel addition to the C. P. R. Elevator "D." W. R. Sinks, of Chicago, is general manager; Mr. Chisholm, resident engineer.

Toronto, Ont.—The Abitibi Pulp and Paper Co. let contracts this week for the construction of their various buildings at Iroquois Falls, and for the machinery. The company already have a saw mill in operation at this point.

Moose Jaw, Sask.—Williams & Robinson, of Rugby, England, have secured an order for a 1,500 k.w. genera-

tor from the city for \$30,505. The city engineer recommended that the Canadian General Electric tender be accepted.

Vancouver, B.C.—The Taylor Engineering and Manufacturing Company have been awarded the contract for the entire smelting equipment, and a new 2,000 ton copper smelter and converting plant that the Granby Consolidated Mining, Smelting and Power Co. propose erecting at Anyox, B.C.

Edmonds, B.C.—The tender of Messrs. Evans, Coleman and Evans for \$25,930 for pipes to carry out the new extensions of the water scheme in various parts of the municipality, has been accepted. A tender for \$1,415 for the erection of the water tower on the North Road was accepted from the Machinery Installation and Contracting Company.

Miscellaneous

Duty on Wire.—At the annual meeting of the Sheep Breeders' Association of Saskatchewan held at Regina, on Wednesday, March 12, it was unanimously agreed that the Federal Government be approached to take off or reduce the duty on fence wire.

Winnipeg, Man.—The total loss in the city of Winnipeg through fire in 1912 was \$775,486. In the province, outside the city limits, the total damage was \$668,680. The allowance for loss by unreported fires is \$15,000, making a total of \$1,477,166.

Dominion Steel Output.—The output at the plant of the Dominion Iron and Steel Co. for the month of February was as follows: Pig iron, 22,700; ingots, 22,500; blooms, 19,900, and rails, 12,475; total shipment, 19,470 tons. The February output of the Dominion Coal Co. was 336,000 tons.

Hamilton Bridge Works Banquet.—The second annual dinner of the engineering department and office staff of the Hamilton Bridge Works Co., Ltd., was held on Thursday, March 6, at the Crystal Cafe, Hamilton. About 85 employes attended. The speechmakers were: Ald. R. M. Roy, W. B. Champ, R. K. Palmer, A. H. Phoenix, C. Struble, R. MacManus and J. S. Hendrie.

Boilermakers Protest.—A large deputation of boiler manufacturers connected with the Canadian Manufacturers' Association waited upon the Minister of Public Works for Ontario on Friday, March 14, and declared that the farmers of the Province were protesting against the new regulations for the manufacture of portable engine boilers, which regulations become effective on July 1 next. The deputation asked that no change be

made in the regulations effective at the present time.

Trade Gossip

The Town of Strathroy, Ont., is offering liberal inducements to any knitting factory or similar institution to locate there.

H. J. Hamilton, manager of Drummond, McCall & Co.'s Toronto branch, who has been in Florida several months for a rest, will resume his work the first week in April.

Harriston, Ont.—The Canada Stove Co.'s foundry, Gray & Son's planing mill, several power houses and the waterworks, were forced to suspend operations on Friday last owing to a flood on the Maitland River.

The Emerson-Brantingham Implement Co., of Minneapolis, represented in Regina by the Tudhope-Anderson Co., some time ago shipped 45 carloads of tractors to Regina, claimed to be a record for the shipment of a single commodity.

August Kastella, chief engineer of the G.T.R. electric power plant here has been appointed engineer in charge of light, heat and power at the Grand Trunk Central Station and Chateau Laurier, Ottawa. He left on Wednesday for his new post.

Mr. A. A. Kinghorn, B.A.Sc., of Toronto, who has been for seven years in the Works Department at the City Hall, and is at present superintendent of the construction of roadways, will sever his connection with this department on March 22, to take a position as manager of the Asphaltic Concrete Co., of Toronto, Limited.

Robert Reford, president of the Robert Reford Shipping Co., Ltd., and one of Montreal's most prominent citizens, died on Saturday, March 15, at his residence, in his 82nd year, after being in indifferent health since last summer. He was born in Belfast, Ireland, and came to Canada in 1845, settling in Toronto, where he engaged in the wholesale grocery and shipping business.

Montreal, Que.—Warden King, Ltd., are adding a new radiator foundry to their already extensive plant at Maisonneuve. It will measure 162 ft. long by 88 ft. wide and will have a capacity of 50 tons per day. The foundations are about completed and the steel work is to be erected by April 1. It is hoped to have the new foundry in operation early in May.

The Dominion Nickel Copper Co., Sudbury, Ont., who, as announced some weeks ago, were erecting a \$20,000,000

Axioms Concerning Manufacturing and Production Costs*

This article as a whole places before manufacturers a wealth of information relative to what is, after all, the life of their business. It at the same time sheds valuable light on the intricacies of accounting and the proper allocation of charges. The list of axioms to be observed is concise and convincing.

THREE factors enter into the cost of each and every article of manufacture—namely, material, labor and expense. These constitute a tripod, or a three-legged stool, which cannot stand if one of the legs be omitted. They may, and do, vary in dimension, but all three are invariably present, and a "cost" which omits any one of them is incomplete and fallacious. The formula becomes $L+M+E=C$, in which L represents labor, M materials, E expenses and C cost. In this primary division the item "labor" includes all labor entering directly into the product, the item "material" all material entering directly into the product, and the item "expenses" (often called overhead charges, or simply overheads) all other labor, material and expenditures of every kind whatsoever.

Axiom 1—Every cost includes three fundamental factors—labor, material, expense.

In most cases, however, the expenses or overheads divide naturally into two groups:

(a) Manufacturing expenses, or those incident to the operation of the factory or mill, being those incurred in utilizing productive labor and material, and in bringing the product up to the point where it is ready to be sold.

(b) Commercial expenses, those incident to the commercial department of the business, including administration, salesmen, advertising, office expenses, etc., being those incurred in distributing and selling the finished product.

It is highly expedient that these two be segregated, so that each may be studied separately.

Axiom 2—The expense factor should be split into two parts—manufacturing, commercial.

Letting the symbol Me represent the former and the symbol Ce the latter, then $L+M+Me+Ce=C$.

A more convenient and indicative form of presenting these elementary facts, and one which the writer has used for many years, is as follows:

- L=productive labor.
- M=productive material.
- PC=prime cost.
- Me=manufacturing expenses.
- SC=shop cost.

Ce=commercial expenses.
AC=actual cost.

If preferred, the foregoing facts may be expressed by the undermentioned formulae:

- $L+M=PC$ or prime cost.
- $PC+Me=SC$ or shop cost.
- $SC+Ce=AC$ or actual cost.

Axiom 3—A manufacturing cost has three phases—prime cost, shop cost, actual cost.

On the appreciation and intelligent use of these facts hang all the laws of good business and that of the profits, for no business can long be operated successfully without a correct knowledge of costs, nor can that be had without a clear grasp of fundamental principles. The competitor most to be feared, while he lasts, is one who does not know his costs, nor understand how to obtain them.

Axiom 4—Accurate cost information is vital to good management.

Simple as are these elementary principles, their correct application in each given case is difficult, and calls for great care and intelligence. To draw correctly the line between productive and non-productive labor and material, through each of the successive stages of a productive industry, requires the combined skill of the expert manufacturer and the expert industrial accountant; the former knowing accurately all the details of the manufacturing or productive processes, and the latter knowing equally the proper methods of combining and using the recorded facts to yield the desired information.

For example, what constitutes productive labor? In the case of a machinist operating a lathe, clearly it includes his wages while his lathe is turning out product and also while it is standing still during the time he is dressing the tool to do the work properly; but if the tool-dressing is done for him, as it is under good modern practice, how shall the time and wages of the tool-dresser be classified? Similarly shall the tool, the file, the waste, the oil, which are consumed or used up in making the product be classified as productive or as non-productive material?

The answers to these questions depend on the surrounding facts in each case, and are as varied as the cases are

infinite in number and variety. The writer is not attempting here to answer such questions, but merely to point out and emphasize underlying principles. This much, however, is clear, that every individual item of expenditure, large and small, must ultimately classify under one of the three great heads above referred to, labor, materials or expenses, and that profit or loss is the difference between actual cost and the net price realized.

Axiom 5—Accurate costs imply the correct classification of every expenditure.

The distribution of actual costs among these heads, or preferably among the four groups or divisions indicated above, varies widely in different industries and with different products. This is illustrated by the following table, relating to four distinct lines of actual product, in which the several elements have been reduced to terms of the actual cost of the product when finished and sold.

	1	2	3	4
L=productive labor ...	28	17	29	19
M=productive material	38	33	25	37
PC=prime cost.....	66	50	54	56
Me=mfg. expenses....	24	20	28	22
SC=shop cost	90	70	82	78
Ce=commerc'l expenses	10	30	18	22
AC=actual cost ...	100	100	100	100
Total expenses				
(Me+Ce)=	34	50	46	44

The figures in the above table illustrate the hopeless state of mind of manufacturers, some of whom still survive, who delude themselves by the belief that the sum of labor and materials (prime cost) represents the actual cost of the product, and that the difference between that and the selling price is profit. They show, on the contrary, that, in the four examples to which the figures relate, the prime cost constitutes only from one-half to two-thirds of the actual cost, and that the expenses or overheads incident to conducting the business and marketing the product contribute from one-third to one-half of the total or actual cost. It seems probable that, if the facts concerning all manufacturing industries could be ascertained and averaged, the "three-legged stool" would be found to stand nearly level, its three legs being approximately of equal length, although differing widely in individual cases.

*Abstract of a paper read recently before the American Society of Mechanical Engineers, New York.

All cost accounting should aim to segregate charges wherever this can be done accurately. Thus, the major part of the items constituting productive labor and material can and should be charged directly to their respective accounts (L) and (M).

Axiom 6—Every productive expenditure should be charged directly to its proper account.

All other items, however, which cannot be so segregated must be aggregated into one or several groups, and their total apportioned among the proper accounts on some carefully determined, but necessarily arbitrary basis.

Axiom 7—All non-productive expenditures should be properly grouped for final distribution.

Manufacturing expenses may be apportioned as a ratio or percentage of labor (L), of material (M), or of labor and material (L+M). The usual bases are either (L) or (L+M). The writer believes that in most cases the closest conformity to actual facts will be attained by distributing manufacturing expenses in the ratio of productive labor, hand and machine, because usually the volume of indirect expenses of works operation will be far more influenced by the pay-roll, that is, by the number and kind of employees, than by the materials bill, which is, the amount paid for the material of production.

Moreover, the former is relatively stable, while the latter fluctuates with market changes. It is, therefore, advisable that (Me) should be a function of (L), that manufacturing expenses should be apportioned as a percentage of productive labor, although in some cases they may properly be apportioned per machine, or per unit of floor space.

Axiom 8—The normal basis for distributing manufacturing expenses is productive labor.

Commercial expenses may also be apportioned as a percentage of (L), of (M), or of (L+M), and frequently are, but more properly they should be apportioned on the basis of shop costs (L+M+Me). The reasons for this are conclusive. Production and selling are two separate and distinct processes. The former brings the product to the point where it is completed and ready for sale; the latter then takes it over and effects the sale. The expenses incurred in each process are for its use only, and have no natural relation to the needs and uses of the other.

To illustrate this, take the case of a manufacturer of cotton cloth who sells his entire product through a commission house or broker. Clearly his whole commercial expense account is covered

by the commission he pays to his selling agent, and this bears a definite ratio to his shop cost, that is, to the cost of his product ready for sale. Now, take the case of another manufacturer of cotton cloth, who maintains his own selling organization and through it distributes his product. Clearly his commercial expenses offset the commission paid by his competitor, and equally bear a definite ratio to his shop cost. Both are most accurately stated and apportioned as a percentage of the shop cost, the cost of the product ready for sale, therefore commercial expenses (Ce) should be distributed as a percentage of shop cost (L+M+Me).

Axiom 9—The normal basis for distributing commercial expenses is shop cost.

When the product is simple and homogeneous, for example, such as pig iron or cotton cloth, one account may suffice for all manufacturing expenses and one other for all commercial expenses, but when it is diverse or complex, each of these should be subdivided into one for each department or for each distinct class of product. In effect, such a business is an aggregate of several businesses, some of which may yield better results than others, or may fluctuate more widely, and a proper accounting system should show the results of each sub-division or department separately, as well as the combined result of all; hence arises in many cases great complexity in cost accounting and corresponding need and opportunity for the skilled industrial accountant.

Axiom 10—An accounting system should show results both by departments and by totals.

In some cases the entire product consists of a single staple article, or group of articles, such as pig iron, window glass, cotton cloth, etc., for which there is a constant demand, and, at some price, a sure sale. In other cases the product must conform to the specifications of the customer, and, therefore, cannot be made up in advance of orders, as in shipbuilding, carbuilding and the construction of buildings. The former is commonly designated as a stock product and the latter as contract work. The difference between these may be expressed as follows:

A stock product is one which is made first and sold afterwards.

A contract product is one which is sold first and made afterwards.

Cost accounting is usually more complex and difficult in the case of contract work than in that of a staple or stock product.

Axiom 11—A contract product may require a more complex

accounting system than a stock product for the accurate determination of costs.

The expenses of general administration overlap the manufacturing and the commercial divisions of an industrial business. Many items can and should be definitely charged to one or the other. Others may arbitrarily be apportioned between them; as, for example, the salary of an official who devotes, say, 70 per cent. of his time to one and 30 per cent. to the other. All others must be aggregated into groups for distribution by the methods adopted above for distributing such expenses; as, for example, by percentages of productive labor or of shop costs.

Expenditures of this kind are infinite in size, kind and number, and call for great skill and good judgment in their classification, which should be determined in advance by a clearly defined code, not left for haphazard decision by subordinates. Such a code, based on intimate knowledge of the business, on a clear perception of the information that the code is designed to yield, and on sound accounting principles, is an indispensable pre-requisite to the accurate determination of costs, and equally to the intelligent conduct of any manufacturing business.

Axiom 12—An accounting system should be embodied in a code of instructions, for the guidance of those responsible for its operation.

For greatest convenience, a code should provide symbols to represent the various accounts and their many combinations. To this end the writer for many years has used a system of letters and numbers. Letters are used to designate important departments and accounts, the significance of each letter depending on its place, as in decimal notation, in the symbol. Thus, the first letter may indicate a department, the second a sub-division of it, and the third a room or smaller unit. Stated numbers are used to indicate accounts relating to expenses of the various kinds or groups. Such a symbol is shown by the following example: (BAC. 10), in which (B) represents the department or the class of product against which the item is to be charged; (A) the shop in which the work is done; (C) the job or machine by which it is done; and (10) the kind of expense to which the charge relates, such as repairs of the machine, foreman's wages, etc. These symbols and an explanation of their meaning and use are printed in a small book of pocket size, copies of which are furnished to all concerned. In this way a correct classification of every charge is made at the time of original entry, after

which tabulation and aggregation of original charges follow automatically in accordance with the predetermined plan.

Axiom 13—Symbols are better than titles for recording charges in an extensive accounting system.

In any business certain expenses or losses occur from time to time which are unusual or abnormal. These may be termed "extraordinary expenses," and require special consideration. As examples of these may be cited a serious loss by fire, a curtailment of product by a strike, an abnormal loss through bad debts, an increase or decrease in value of land, etc. The loss or profit thus arising must, of course, be covered into the treasury, but this may better be done through a debit or credit to the surplus account than through a charge to the profit and loss account of the current year, for the latter plan would distort the statistical record of the year by including items not common to normal years. The best plan is to charge those which are abnormal to the surplus account.

The proper purpose of the annual account is twofold:—

(a) To show the results of the year's operations.

(b) To contrast these results with those of preceding and succeeding years. On the other hand, all extraordinary gains or losses must be accounted for, and this may best be done through the surplus account. In this way both purposes are accomplished.

Axiom 14—Extraordinary gains or losses, in order not to distort the statistical value of the annual profit and loss record, should be covered into the surplus account between the closing of the books for the old year and the opening of the books for the new year.

Interest on borrowed capital is a distribution of profits, not an expense, although often erroneously treated as the latter. To illustrate this, suppose the case of two manufacturers ((A) and (B), each having \$200,000 invested in his business and each realizing 10 per cent, or \$20,000 net profit, available for dividends on a year's business. All of the capital of (A) is contributed in cash, while (B) has only \$100,000 of cash capital, and another \$100,000 of borrowed capital, on which he pays 5 per cent. interest. At the close of the year (A) is in position to pay \$20,000 in dividends to his stockholders, a 10 per cent. return on their investment, but B, after paying \$5,000 as interest, is in position to pay \$15,000 in dividends to his stockholders, a 15 per cent. return

on their investment. Evidently the actual profits from the operations of the year are the same in each case, only the ownership of the capital invested and the distribution of the profits being different.

The accounting system should show the actual profit realized, regardless of its distribution to the owners of the capital invested in the business. On the other hand, it is expedient that interest on temporary loans and on time purchases, if availed of, rebates and discounts of customers' notes, should be treated as current expenses normal to the conduct of the business. In like manner, discounts earned by cash payments should be treated collectively as part of the current earnings of the year, or else be covered into the net costs of purchases.

Axiom 15—Interest on borrowed capital should not be treated as an operating expense but should be charged direct to the profit and loss account of the year.

Interest on all capital invested in a business may or may not be deducted before stating the final profits of the year. Here no principle is involved, but merely convention or individual preference. Usage, however, has practically determined that it shall not be deducted; that the final or net profit should indicate the return on capital, the amount which capital has earned. Stated thus, it can readily be compared with what the same capital would earn if invested otherwise: as, for example, in government or railroad bonds, mortgages, etc. If interest is deducted at all, as is done, for example, under some profit-sharing plans before allotting anything to the beneficiaries of the plan, it should be computed on the total capital invested in the business, including therein the surplus account; that is, surplus profits of previous years retained in the business and invested in plant or merchandise.

Axiom 16—Final profits properly signify the amount earned by the capital invested. If interest on capital is deducted, this fact should be stated, and interest should be computed on the total capital employed.

Where a business is divided into several or many departments, it is very desirable that the accounting system should show the profits or earnings of each of them separately, and this is usually feasible, except as to annual depreciations and as to interest charges. In some cases, either or both of these items can accurately be distributed among the several departments, and, if

so, they should be so treated. Where they cannot be so distributed, they should be deducted in a lump from the sum of departmental profits, and in this case it becomes convenient to adopt terms to designate clearly the profit account at its various stages. For this purpose the writer has found the following terms satisfactory:

Gross profits—The aggregate profits of all departments, prior to deducting depreciations and interest.

Net earnings—The gross profits after deducting depreciations.

Net profits—The net earnings after deducting interest on borrowed capital.

In comparing the results realized in two or more comparable concerns or businesses, it is essential to contrast profits at the same stage in each case, and to employ terms which are mutually understood as to their precise meanings. No standard as to these terms has yet been established. The proper basis of comparison usually is that indicated above by the term net earnings, which eliminates the variations due to the employment or non-employment of borrowed capital.

Axiom 17—Terms used to designate profits should indicate clearly the stage of profits to which they refer, and should be mutually understood.

Inventory valuations are an important factor in determining profits. Usually an actual inventory is taken only once a year. The merchandise inventory includes raw materials, stock in process, finished goods, and general supplies. A standard basis of valuation for each of these groups should be adopted and maintained from year to year. Raw materials, such as pig iron, raw sugar, baled cotton, ingot copper, etc., are often subject to wide fluctuations in market values or costs, and the question thus arises as to the proper inventory valuation of them, whether at cost, at market value, at date of inventory, or on some arbitrary basis. If the effect of such fluctuations is negligible, being small in ratio to the annual total of the account, either of the first two methods above stated may be used. If the fluctuations are large, however, either in range or in their effect on the annual total, that is, if they materially influence the profit and loss account of the year, some arbitrary plan of accounting for them should be adopted.

In devising this, the twofold purpose of the annual account, the operative and the statistical, should be kept in view. If the effect of the fluctuations is moderate in its ratio to the annual account, a sound method consists in taking the mean, either of market prices or of actual purchase prices for, say, three or

five years, as the basis for inventory valuations, and also for use in the compilation of costs, thus conforming to the average trend of market values, but avoiding frequent and temporary changes. If, however, the effect of these fluctuations is serious or vital in determining the results of the business, a new factor is brought into the accounting problem, namely, that of trading or speculating on the market.

In the case of a sugar refinery or a cotton mill, for example, large profits or losses may result from market changes in the price of raw sugar or of baled cotton, or from the operations of the purchasing department. Obviously such gains and losses are totally unrelated to the economy and efficiency of the productive department, and to include them in its accounting might so distort it as to destroy its usefulness and its statistical value. In such cases a separate trading account should be established, through which to ascertain the profit or loss of the year in operating on the market for the raw material, the latter being charged to the manufacturing department at a constant price, conformed from time to time to average market conditions, this price being used also for inventory and cost purposes. In other words, the results of speculation on the market, however legitimate or necessary, should be segregated from the results of the normal operations of the plant.

Axiom 18—Speculative profits and losses should be segregated from those due to the normal operations of a business.

The inventory valuation of stock in process, that is, of stock in a partly manufactured condition, should be such as to cover the prime cost of the material and of the productive labor already expended upon it, plus a ratable charge for manufacturing expenses. The inventory valuation of finished stock, that is, of stock completed ready for sale, should be on the basis of shop cost, not of actual cost, because the latter includes the cost of selling, and this has not yet been incurred.

A paradox, apparent but not real, is created when the cost of a product is substantially reduced, because thereby the inventory value, and therefore the profit of the year, is reduced. If the inventory value at the beginning of the year were \$1,000, and if during the year the cost were reduced 10 per cent., obviously, if the quantity on hand at the close of the year were the same, the inventory value would be \$900, thus showing a shrinkage of \$100. In the following year, however, this apparent loss would be converted into an actual profit.

Axiom 19—A reduction in cost implies a corresponding reduction in inventory.

The annual inventory may properly include as assets certain items previously classified as expenses. One example of this kind is the premium on unexpired insurance. Another is the cost of a trade catalogue intended to serve, say, for five years. To charge the whole of important expenditures of this kind into the current expense account of the year in which they are incurred would tend to distort its statistical accuracy, and hence would be bad accounting. The proper treatment of such expenses is to determine the period they apply to, and to charge off a proportionate part in each month or year during that period, carrying the remainder on the inventory.

Axiom 20—Expenditures in one year which cover the requirements of several years should be distributed over the years to which they fairly apply.

The inventory valuation of all property other than merchandise should be on the basis of its fair value in the business as that of a going concern, which usually is the cost to replace, with due allowance for wear and tear. An annual inventory of all property, by actual enumeration and count, is indispensable to the proper conduct of any manufacturing business, and in some cases more frequent inventories of the merchandise stock are expedient. Without such annual inventories, no determination of annual results is reliable or of much value.

Axiom 21—An annual inventory of all property is indispensable to accurate knowledge and to good management.

The question of depreciation of fixed property enters into all industrial accounting and should be treated in connection with the inventory. In this, as in all discretionary matters of accounting, the aim should be to find and follow the mean between ultra-conservatism and radicalism. All fixed property, except land, depreciates and tends to become obsolete. Normal repairs and maintenance should, of course, be charged to current operating expenses, not added to cost or value, and these should fairly be considered in fixing the ratio of depreciation. Where a building or a machine is maintained in perfect condition, obviously it depreciates more slowly than one which is neglected. A building may be so maintained as to depreciate little or not at all.

The proper rate of depreciation for each class or kind of fixed property is a matter of good judgment, for which no rules can be laid down. It may be as

low as 1 per cent. per annum, and in exceptional cases may be as high as 20 per cent. Usually it ranges from 2½ to 10 per cent. When profits are abnormally large, the allowance for depreciation may wisely be larger than when they are merely normal, but the normal allowance should be made even when no profit is realised. Under average conditions it usually ranges between 10 and 15 per cent. of the annual profits.

A revaluation of all fixed property by outside experts or appraisers, at intervals of five or ten years, is expedient and usually worth its cost. Abnormal increases or decreases in the value of such property, as for example an increase in the value of land, or the loss due to the demolition of an obsolete building, should be covered into the surplus account, not into the profit and loss account of the year.

Axiom 22—Valuations of fixed property should be subject to annual review and to fair depreciation.

Finally, the aim and object of every accounting and cost system should be to afford true and accurate information as to facts. It is based on facts; it should embody and present facts, and naught else. To exaggerate facts and to show fictitious profits and values, is no worse than to depreciate facts and to conceal true profits and values.

Axiom 23—An accounting system should present facts, without bias in any direction.

Accounting, in its application to general business affairs, has long been a highly developed science, but is comparatively a new one in its specialized application to modern industry, with its vast and complex development. The creation of a **Correct Science of Industrial Accounting and Costs** should be the desire and aim of all who are concerned with industrial management. To accomplish this, three things at least are needed:

(a) Clear understanding of fundamental principles.

(b) Definite terminology, generally understood and accepted.

(c) Free interchange of the data of practice, whereby the adoption of sound principles may be promoted, the experience of each may be available to all, the best methods may become established, and, above all, a standard system may ultimately be created.

The accomplishment of these results, by affording complete and accurate knowledge of the essential facts pertaining to industrial efficiency and to the costs of production, will tend greatly and permanently to promote the development of any industry.

Typical Methods of Attaching Chucks to Lathe Spindles *

By Fred Homer

The manner in which a lathe chuck is attached to its spindle has a vital influence upon the accuracy of a considerable portion of the work which is turned and bored in a lathe. Again, numerous adaptations of chucks purchased from manufacturers are required to suit individual cases. The article deals with the principal points involved.

WHETHER a face-plate, driver-plate, or chuck proper is attached to the spindle nose, or whether the adapter or back-plate fits it, instead, makes no practical difference. Accuracy of replacement is the primary requirement, those cases excepted where the chuck is attached permanently. The construction should be such that a moderate amount of wear does not affect the accuracy of running, this being secured either by the combination of a screw and a square shoulder, or by a taper and screw, or by a taper alone.

Common Spindle Noses.

Fig. 1 illustrates a collection of common spindle noses. That most frequently used is indicated by sketch (A), being threaded with a fine or a coarse thread, according to makers' ideas practically up to the shoulder. A better method, however, is to leave a portion of the nose plain, either fore or aft of the threaded part sketches (B) and (C), the chuck being bored out to match. The threads are thus relieved of some strain, a rather more accurate alignment is assured, and what is very important, the chuck is centered properly in the case of (B) before screwing-on commences, and the risk of cross-catching the threads and bruising them, through the threads not aligning correctly, is avoided. Sometimes the first thread of the screw is cut off squarely, to render the starting-on more easy, and to obliterate the thinning of the thread to a sharp wedge. Usually, the shoulder on the spindle is formed solidly with it, but an exception is seen in sketch (D), where a hardened collar is shrunk on

lathe, shows an alternative to the usual square shoulder, the collar being coned and the chuck face bored out to match.

Chucks Keyed and Bolted on.

In heavy lathes, where the chucks are generally fitted permanently, they are either keyed or bolted on, the latter being more usual. A keyed-on chuck is

taper plugs which assist in driving the plate or chuck, and in some spindles, principally for turret lathes, the end is flanged without the usual projecting nose, the chucks or adapters being bolted thereto.

Taper Noses.

Among unusual methods of attachment are the Pratt and Whitney fitting,

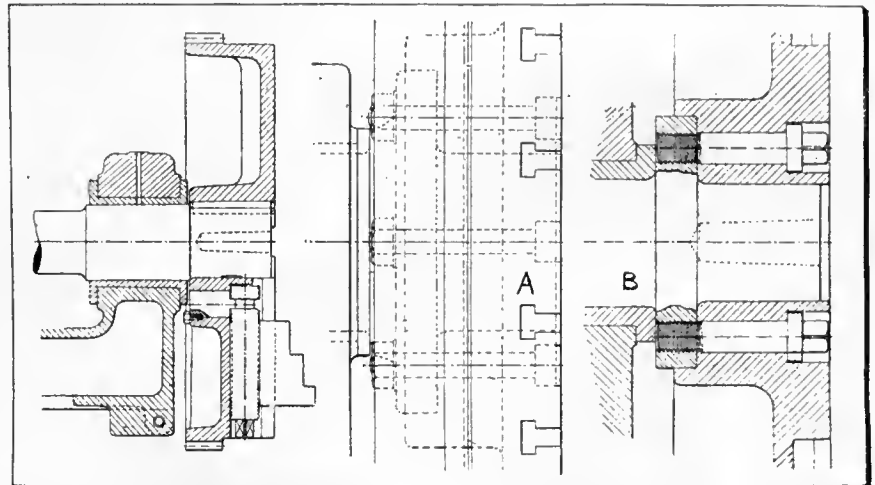

FIG. 2. LARGE CHUCK KEYED ON.

FIG. 3. LARGE CHUCKS BOLTED TO FLANGED SPINDLES.

illustrated in Fig. 2, being on a 13-in. centre lathe. The spindle in this case is not driven, but all the work of rotation is effected by a pinion meshing with the tooth ring on the chuck body.

Two examples of attachments for very heavy lathes are seen in Fig. 3, that at (A) having bolts with nuts at the back of the spindle, which is the usual design when space permits, while in the case of (B), collared screws are sunk

and the Hardinge nose minus screw threads. The former Fig. 4, is applied to certain engine lathes, and is interesting from the fact that the threaded portion is located adjacent to the bearing and the chuck fits on the conical bushing at the front, and is centered thereby. The usual shoulder or flange is dispensed with, and there is very little overhang from the bearing. The rear bearing receives the thrust.

Fig. 5 represents the Hardinge spindle end, with chuck plate in position; this is employed on bench lathes. The exterior being plain, it can be hardened and ground accurately. A grub-screw is let into the chuck boss to form a key which serves to draw the chuck firmly on to the nose, through the action of a pair of keyways set at opposite angles, according to which direction the spindle runs.

Internal Threads and Tapers.

Although the internal thread is largely obsolete, and is never employed on ordinary lathes, it still finds a place in some classes of lathes, principally those for brass-finishing, and forms a means of attaching small chucks, which are not

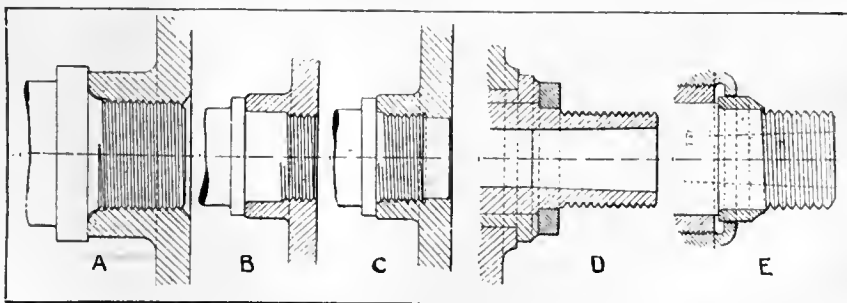

FIG. 1. TYPES OF SPINDLE NOSES

and subsequently ground. The end-thrust is taken against the rear spindle bearing. Sketch (E), from a French

into recesses in the chuck, thus allowing the spindle shoulder to come immediately against the front bearing. Sometimes the bolts are supplemented by dowels or

*From "Page's Weekly."

conveniently screwed on to the nose in the ordinary way. A fairly coarse internal thread is formed in the nose, and the chucks or adapters butt up against the end of the spindle. The internal

fact that the holes are drilled too closely to size, or that they are slightly out of alignment with those in the chuck body. There should invariably be a little freedom in the back-plate holes or in the

The stiffening of plates with ribs shown at (B), Fig. 6, is desirable for heavy turning, especially in the case of the larger plates; the tendency to vibration being minimized.

The overhang of a chuck when attached to the standard type of back-plate is a serious objection, if the body is thick, and the construction heavy, because it not only interferes with accurate turning, but imposes extra strain upon the spindle and increases the wear in the journals.

A frequent practice is to reverse the back-plate so that the front face of the chuck is brought closer to the end of the spindle nose and this can only be done when the hole in the chuck is sufficiently large to admit of the boss, as in Fig. 8. Screws or bolts are used for attachment, and the front of the plate is bossed up sufficiently to form a facing for contact with the spindle shoulder.

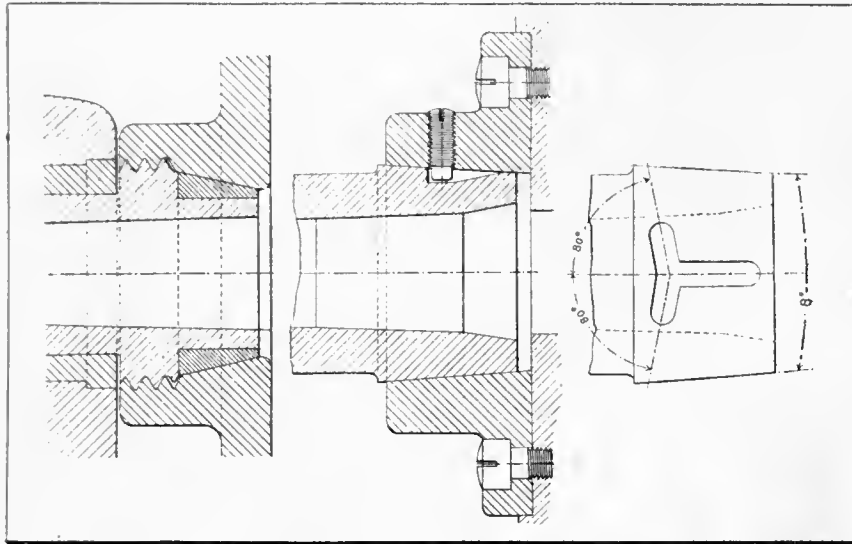

FIG. 4. SPINDLE NOSE WITH TAPER AND THREAD ADJACENT TO BEARING.

FIG. 5. THE "HARDINGE" SPINDLE END WITH CHUCK PLATE IN POSITION.

taper which is utilized for receiving centres is also employed to carry small chucks on their adapters.

The Use of Back-Plates.

When a chuck is purchased to be fitted indiscriminately to any lathe, an adapter or back-plate is required to render its proper fitting practicable. In instances in which a line of special lathes is built, it is possible to arrange that all the chucks shall be screwed direct or otherwise fastened to the spindle without an extraneous plate, but this is exceptional. The ordinary chuck has a recess turned in the back, which is warranted accurate, and a back-plate must be made to fit this and to run accurately upon the spindle. If these two requirements are met, the matter of assembling is simple.

The errors which are liable to creep in may be classified as.

(1)—Inaccurate production of the back-plate, due to carelessness in threading the bore and fitting it to the spindle, and in finally trueing the face. An unsuspected cause of untruth in facing off the plate is occasionally traceable to end play in the lathe which prevents any attempt to turn the face true. A back-plate which is convex upon the face cannot be depended upon to hold the chuck true, neither can one which jams too tightly into the chuck recess, nor on the other hand is too loose a fit.

(2)—Inaccurate attachment of the back-plate, by reason of its failing to bed down to the bottom of the chuck recess. This is often caused by tightness of the screws or bolts, due to the

chuck holes if through bolts are employed.

(3)—Weakness of the back-plate may be responsible for inaccurate turning, especially when taking heavy cuts; a plate which is too thin or has bolts of insufficient size must not, therefore, be employed for heavy work.

Types of Back-Plates.

Fig. 6, sketch A, shows the ordinary kind of adapter or plate fitted to a

DRYDOCK AT PRINCE RUPERT, B.C.

THE Grand Trunk Pacific \$3,000,000 dry dock at Prince Rupert is being constructed as fast as the contractors know how. So far, the layout and partial completion of the area to be used for wharves, water front, yards, etc., upon which the various buildings will be located, has only been undertaken. Tenders are now being called for the construction of twelve pontoons for the floating dock. The United States Steel Products Co. has been given the contract for all the steel, the Dominion Iron and Steel Co. being unable to tender, on

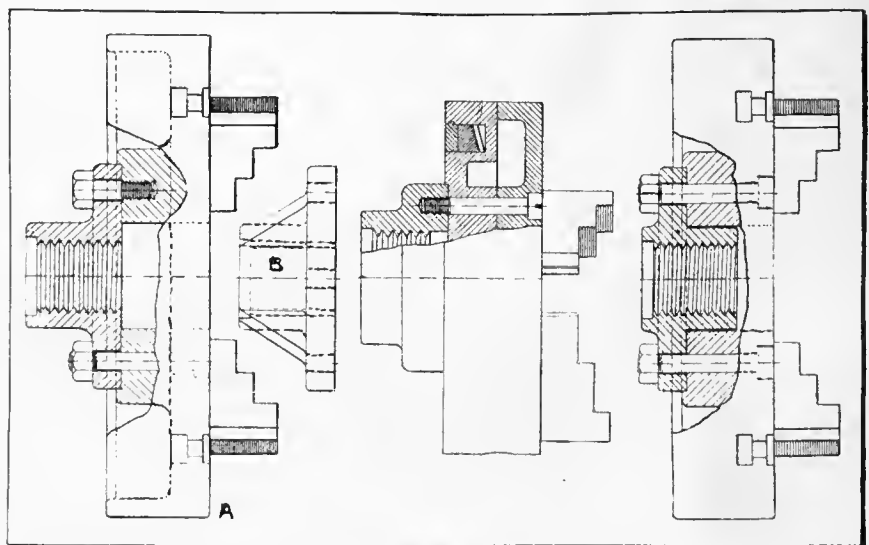

FIG. 6. STANDARD TYPES OF BACK PLATES (ATTACHING CHUCKS).

FIG. 7. SCREWS PASSED IN FROM FRONT OF CHUCKS.

FIG. 8. BACK PLATE REVERSED, WITH BOSS INSIDE CHUCK TO REDUCE OVERHANG.

chuck, with a set-screw in the upper half, and a bolt employed in many chucks alternatively, in the lower for contrast. A more convenient arrangement in certain cases is that seen in Fig. 7, the screw being passed in from the front.

account of the vast amount of work already in hand. Another American firm has been given the contract for the erection of a chimney, 183 feet in height. A substantial amount of construction will have been finished before next winter.

PREVENTION OF BLAST FURNACE ACCIDENTS.

SAFETY Bulletin No. 1, issued by the Inland Steel Co., Chicago, for distribution among its employees at Indiana Harbor, Ind., contains an article on the Prevention of Blast Furnace Accidents by J. E. Thropp, Jr., superintendent of blast furnaces. Mr. Thropp says that while work around blast furnaces is generally considered dangerous because of the presence of gas, the danger of slips, and breakouts of molten metal, most of the accidents are due to other causes. In 1912 the accidents at the Indiana Harbor blast furnaces were distributed as follows: Blast furnace operations, 20 per cent.; mechanical department, 33 per cent.; yard department, 33 per cent.; switching yards, 14 per cent. The following suggestions are given:

If the presence of gas is suspected around the hearth, light it with a piece of burning waste so as to avoid danger of being gassed.

Furnace keepers and helpers must be sure that tapping holes, iron runners and shutters are perfectly dry before using them. A little damp clay or wet scrap may cause an explosion.

Keep away from cinder ladles when they are being filled, especially in wet weather.

Attention is called to the danger of driving keys to support bootlegs, or tightening nuts on tuyere caps, doors of stoves, etc., when the blast is on.

Avoid working under dust catchers when furnace is hanging. Keep away from the tuyeres and avoid looking in the peep sights unless it is one of your duties.

Men working in boiler house should see that slide is well mudded, and that "Danger—Do Not Move" signs are hung on gas valve and blow-off valve to prevent possibility of gas or steam getting in the boiler.

Beware of hot flue dust. It will run like water when it strikes the ground or any dump or wet surface and will cause a serious burn if it gets in your shoes. Either wet it down with a hose or get a plank to stand on when shoveling it away.

Bear in mind that practically all blast furnace accidents can be avoided by using common sense, keeping your eyes open and not taking chances. The human element is the most important factor in accident prevention and should receive the greatest attention.



MACHINE TOOL EXHIBITS AT FOUNDRYMEN'S CONVENTION.

THE Foundry and Machine Exhibition Co., is not yet prepared to allot space for the foundry exhibition to be held at Chicago in October. A large

number of reservations have been made, however, particularly interesting among them being the space requested by a number of machine tool builders. It is proposed to have such a representation of machine tools as will permit the display of a completely equipped machine shop. In commenting upon the special interest which the machine tool builders are taking in this exhibit, Alfred Marshall, of the Marshall & Husehart Machinery Co., Chicago, stated that not only did the foundries offer a wide market for the sale of machine tools, but more important than that was the opportunity for illustrating to foundrymen the best methods for machining castings. It was pointed out that no greater opportunity for manufacturing economy is presented than in the development of a co-operation between the foundry and the machine shop, so that rough castings when received will require only the minimum and most easily accomplished machining.



QUEBEC MINERALS.

IN our issue of March 20, some general observations were made concerning the mineral production of the province of Quebec, during 1912. As a supplement to the information here given, an itemized statement is appended herewith, together with a comparison relative to the year 1911:—

Materials.	Quan.	Value, 1912.	Value, 1911.
Asbestos, tons	111,175	\$ 3,059,084	\$3,026,306
Asbestie, tons	25,471	23,358	19,802
Copper and Sulphur Ore, tons	62,107	631,963	240,097
Gold, ounces	980	19,924	11,800
Silver, ounces	26,526	14,591	11,500
Bog iron ore, tons	4,041
Ochre, tons	7,054	32,010	28,174
Chromite, tons	2,469
Mica	99,463	76,428
Phosphate, tons	164	1,640	5,832
Graphite, pounds	1,210,278	50,680	33,613
Mineral water, gals.	39,452	9,854	65,648
Titaniferous ores, tons	2,949	4,935	5,684
Slates, squares	1,894	8,939	8,248
Cement, barrels	2,684,002	3,098,350	1,931,183
Magnesite, tons	1,714	9,645	6,416
Marble	250,939	143,457
Flagstone	600	500
Granite	358,749	308,545
Lime, bushels	1,705,937	455,570	284,334
Limestone	1,361,082	1,128,402
Bricks, M	100,146	1,284,232	1,129,480
Tiles, drain and sewer pipe, pottery, etc.	203,100	142,223
Kaolin, tons	40	520
Feldspar, tons	110	2,200	600
Peat, tons	500	2,000	700
Glass sand	152	418	1,179
Sand	81,800	33,200	62,000
Quartz	1,125
		<hr/>	<hr/>
		\$11,017,046	\$8,679,786

CONDITIONS NEAR COCHRANE.

MR. B. E. Fernow, LL.D., after making a rough inspection of conditions in the clay belt of New Ontario, has forwarded his report to the Hon. Clifford Sifton, chairman of the Commission of Conservation. Observations were made along the National Transcontinental Railway from Cochrane, east and west, for about 200 miles, during October, 1912. Of the commercial aspects, Mr. Fernow, says:—

"While the country is densely wooded it is by no means all 'timber.' Indeed, from the point of view of saw-mill supplies, the woods are disappointing. Even for pulpwood the supply is not what the uninitiated may suppose, and what has been believed to exist. The early explorers traveled by canoe, and, hence, reported only the better developed timber of large sized white spruce, aspen, balsam poplar, which skirt the rivers on the well-drained portions in quarter to half mile belts, without realizing that, in the swamps beyond this belt, the bulk of the forest growth is black spruce of small size. There is also an idea abroad that the small trees which cover vast areas are young trees, the result of recent fires. While in some cases this may be a correct diagnosis, it is not so in the majority of cases seen, in which the small trees are stunted, of considerable age and extremely slow growth, the result of poor drain-

age, as can be readily established by counting annual rings.

Forest Growth Classification.

"An attempt was made to classify from the standpoint of use, the forest growth visible from the railway. Even a layman may readily recognize at least three development classes using sizes for their distinction, namely the most frequent maximum heights and maximum diameters, not considering the "giants," i.e., the unusual sizes which may occur occasionally in any class. All growth remaining below 40 feet in height and below 5 inch maximum diameter was classed as scrubwood; that above these dimensions, but remaining mostly below 60 feet and 8 to 10 inches in maximum heights and diameters, as second class, and that above these latter dimensions, making an average of 12 inches and 80 feet, as first class. In nature, these classes grade into each other, and to allow for these intermediate gradations two classes were interpolated between each of two main classes, namely those somewhat poorer than the best, and those somewhat better than the class below, the more or less frequent occurrence of the main class dimensions serving for these interpolated classes, so that, altogether, seven classes were distinguished.

"To check the judgment, a few measurements of diameters on the stumps to be found in the clearings for right of way were made, which measurements, indeed, led to the classification. These stump areas in front of the forest type itself were also used as checks to classify the type properly, since along the railway the better sizes have been culled.

Results of Inspection.

"Hardly 10 to 15 per cent. of the forests is of the first class, i.e., containing sizes fit for logging. From 35 to 50 per cent. of the area may, by picking, furnish small-sized pulpwood. From 35 to 45 per cent. of the area is, from the stand-

point of wood supplies, useless; it is either muskeg, near muskeg or scrubwood of a size hardly fit for fuel. The record in seven development classes ran as follows, beginning with the best lands, in per cents.: 4, 5, 14, 21, 17, 18, 22; the last two figures representing muskegs, open and with scrubby ground.

"In corroboration of the relatively small value of the timber, I may cite the statement based on cruising of one of the lumber companies situated on what are considered two of the best townships, which, therefore, may be accepted as fairly representative of the better class lands, including river banks. Thirty per cent. of their holdings are found unproductive, the productive land running 8 cords of pulpwood of 8 inch average diameter, or, possibly, 4,000 feet B. M. per acre.



HYDRAULIC TRANSMISSION TRUCK HAULS 45-TON LOAD.

ANOTHER remarkable trailer haul was recently made by the LaFrance hydraulic truck. A frame for the door of the new vaults which are being put in the bank clearing house of New York city had to be moved through the streets. This frame, made by the York Safe & Lock Co., was brought to New York on a lighter, and delivered at pier 11, East River. A four-wheel wagon, which, when empty, weighed 16,400 pounds, was requisitioned to carry the frame. The latter was 7ft. 6in. wide, 9ft. long and 3ft. 6in. thick, and weighed exactly 52,600 pounds. The LaFrance Hydraulic truck was itself loaded with five steel plates for this vault, which in the aggregate weighed 12,100 pounds. The truck weighed 4½ tons, so that the total load to be moved was 90,100 pounds.

The shortest way to deliver this load to its destination would have been through Wall Street, but permission to use this was denied on the ground that

the street paving would not support the load. The truck had, therefore, to proceed down Front Street to South Ferry, and then up Whitehall Street to Bowling Green, and up Broadway to Cedar Street. Two horses were hitched to the pole of the truck so as to control this and allow the trailer to be steered right. A grade of 4½ per cent. was encountered on Broadway at Bowling Green, just above Beaver Street. The frame was placed upon timbers mounted on the truck, but the load was so great that it crushed the timbers, so that a stoppage had to be made and the frame jacked up and new timbers placed underneath. The only street damage done was the breaking of one small manhole on Whitehall Street.

In order to show its remarkable tractive effort, the truck was stopped with its load on the 4½ per cent. grade at Bowling Green, and had no difficulty in starting again. The draw bar pull required to start this load and keep it moving on this hill was a little over 9,000 pounds. This demonstration illustrated very forcibly the fact that because of the hydraulic transmission this truck is capable of exerting a tremendous draw bar pull at starting and at low speeds. The speed at which the load was hauled was four miles per hour, and it would have taken at least 20 horses to do the job, going at not over 2½ miles an hour at most. The fact that the load was moved at four miles an hour instead of 2½ obviated the breaking of a large number of manhole covers and prevented damage to the road. The load was so heavy that after the automobile had delivered the truck and frame to its destination the very weight of the equipment standing still made the wheels cut into the asphalt, although moving along the road it made no impression. The Hydraulic Truck Sales Co., Broadway, New York, are distributors of this truck, and to them we are indebted for the photo and data.



HYDRAULIC TRANSMISSION TRUCK HAULS 45-TON LOAD.

The Useful Life of Machinery and Its Economic Limits

"Times Engineering Supplement"

There are two limits to the useful life of any machine or group of machines—the time during which it may be made to perform its work, whether or not the work is being done at a profit, and the time at which it is or may be superseded by some other machine or group of machines which will perform the same work at a price that will give the user a larger profit. The accompanying article is confined almost entirely to the second limiting cause, for when any machine is unable to perform its work properly, its economic life, if not at an end, is within measurable distance of it.

DURING the last 30 or 40 years, what is practically a revolution has taken place in the views of engineers and of users of machinery with regard to the economic life of machines. Forty years ago, totally opposite ideas on the subject of the construction of machines prevailed in Great Britain and in the United States.

In Great Britain, the engineer and the manufacturer designed and constructed machines in such a way that they would go on working continuously, with very short intervals for stoppages for repairs, over a long period of years. Even at the present day, in certain districts, old machines may still be seen performing the work they have done for something like 30 years. In the United States, on the other hand, the idea of the designer, the manufacturer and the inventor has been to construct a machine which would do its work fairly well during that time, and which could be made for as small a sum as possible.

The idea underlying English practice was that it was cheapest to buy a very good machine and keep it running as long as it would stand up to its work, while the idea underlying American practice was that the smallest amount possible should be spent upon the machine, because, with the rapid march of invention, it was probable that in the course of a few years something better would be invented, and it would then not be wasteful to throw the old machine on one side and replace it by a new one.

So far was the idea carried in the construction of American machines, that, in those which went over to Great Britain a generation ago, repairs were found to be practically impossible. Great skill was shown in covering up what according to British standards would be considered bad workmanship, and in making the machine, for a certain limited period, perform the work for which it was designed. Once, however, the machine showed signs of failing, all attempts at repair were found to be absolutely futile.

The visits of English engineers to America and of American engineers to Britain, together with the constant interchange of ideas between the engineers practising on the two sides of the At-

lantic, have had their natural result, and machines which are constructed in the Old Country at the present day owe a great deal to American ideas, while there are also indications that American engineers have adopted a good many English ideas.

Closeness of Fitting.

Side by side with this revolution of ideas with regard to the construction of machines, another revolution has been going on, of at least equal importance. The construction of machines of all kinds is quite different from what it was 30 or even 20 years ago. The English mechanic who considered himself a good fitter thought that he had done remarkably well if he worked to 1-16 in. or 3-64 in., but now fitting to 1-1000 in. or still less has become quite common. As a condition of this enormous advance, a revolution in machine tools has taken place. The hand tool has given place entirely to the machine tool, and hand working to power working. Further, engineers have studied more closely the conditions of the problems involved in the machines they were designing or constructing, and this examination has often shown that large amounts of metal had previously been wasted. The rule in the old days was to give plenty of material in order to make sure of a good job.

Again, with the advance in the quality of the different classes of metal, with the improvement in the manufacture of steel, with the better steels that have been put upon the market, closer and closer working to theoretical figures has become possible, without trenching on the necessary margin of safety. Thus machines have been lightened in nearly every respect, while they have been turned out in better form, and are able to do their work better than the older machines.

In the United Kingdom, the result of these factors has been the assimilation of a good many American ideas, leading to the construction of much more efficient machines than were dreamed of 30 years ago, and of machines which are able to perform work which at that period was thought to be possible only by hand labor. Thirty years ago the remark was frequently heard that such and

such an operation demanded "the impress of the human mind;" to-day that remark is never heard, and there is abundant proof that machines have been able to imitate the impress of the human mind, and in many cases to improve upon it.

Conditions of Change.

The changes noted above have led to the idea that the state of change is good. Engineers and managers of factories formerly considered that change was bad; now, though they dread change, they are constantly on the look-out for some new machine that will perform the work of the machines they are employing, in such a way as to provide a higher profit. It is possible that the idea of change has been carried too far. Change at the right time leads to increased profits and to the increased prosperity of the factory adopting it; but constant change, or change applied at the wrong time, must lead to financial disaster. It must be remembered, that, notwithstanding the improvements that are so constantly taking place in machines designed to perform every kind of industrial work, the ideal condition for the manufacturer is the continuous operation of every machine or group of machines from year's end to year's end. Every change he is obliged to make is an expense, and must lead to loss of profit, unless the change itself provides sufficient profit to make up for that loss.

When to Change.

This consideration leads to the question, "when does it pay to change a machine or group of machines, to supersede those that are performing certain work by others?" The answer is supplied by a very simple economic law. It pays to change a machine or group of machines when the new machine or group of machines will bring sufficient additional profit, during its useful life, to pay for the cost of the change, and something over. The smallest profit at which the change should be made is that which is sufficient to cover all costs of making the change. It may and does often happen that a manufacturer is obliged to make a change in the machines he is employing for certain work in order to meet the competition of other manufacturers.

Other firms may be turning out similar objects at a lower cost or in such a form that they command a higher price on the market. Again, in certain classes of product, appearance counts for a good deal in the matter of price; and the fact that his rivals are turning out produce with an appearance which commands a higher price may oblige him to change his machinery. The keen stress of competition also may force him to take the same course in order that he may be able to produce at a lower cost, under the penalty of being driven off the market. In either case, the reduced cost of production, or the increased price obtainable, must be sufficient, during the useful life of the new machines, to pay the whole cost of the change.

Factors to be Considered.

The greatest difficulty is perhaps that of estimating the useful life of the new machine. It may have been working in the shop of a rival only a short time, not long enough to enable a prophesy, on the one hand, how long it will perform its work usefully, or on the other of how soon it will be superseded by a machine with further greater improvements. In attempting the estimate, the second factor, the probable date of its supersession, must be left out of account. The time cannot be estimated, but when it does arrive, the same economic law must be applied as when the machine was installed.

It is also difficult to estimate its working life when it has been in use only a short time. The longer the change is deferred, the more data will be available for forming a judgment. In such cases, the consulting engineer who specializes in the particular work in question should be of service. He should have observed not only this new machine, but also others of a somewhat similar kind, and he should have figures at his command which will enable him to form a fairly close estimate of its probable useful life. One rule may safely be given, that it is wise to allow a fairly large discount from the estimate. Machines vary considerably in their useful life in different hands, and it is sometimes startling to notice what great differences exist in the handling of them in certain factories as compared with the handling of similar ones in other factories.

On the other side of the account, also, great care must be taken that all the factors of expense are taken into consideration. Not only must the cost of the new machine be thought of, but also the cost of fixing it, and of the disturbance to the factory while it is being installed, and while the operators are getting accustomed to it. No matter how perfect it may be, or how skilful its attendant, a new machine is a new machine, and time will be required for it

to settle to its work, and for those who are looking after it to become used to its ways. During that period, produce is wasted, time is lost, and there may be waste of other sorts.

In some cases, also, cost may be incurred in placing a new product upon the market. A maker who has been noted for making an article of a certain grade for a number of years has to spend a certain amount of money by advertising in various ways, often by giving away some of the new products, before he can establish a trade in the article produced by the machine. This item must go down on the expense side of the account. On the other hand, the old machine itself may be worth something, at the worst as old metal, or possibly in the second-hand machinery market.

BORING OUT A LARGE CASTING.

THE illustration shows how a heavy engine lathe was converted into a horizontal boring mill in the shop of the Hall Engineering Works Montreal. The casting to be bored and faced was the frame for a Corliss engine. It weighed 11,000 pounds, and was, therefore, a somewhat awkward job to handle in a shop not equipped with a traveling crane.

The first step in the operation was to run the lathe saddle behind the tailstock, where it would be out of the way. The casting was then raised by chain

and stud holes were drilled by portable electric drills. The ends were faced by means of a special slide rest attached to the boring bar.

The entire operation of boring and facing was completed in about thirty hours, a first class job resulting.

ELECTRICITY AT CAPE BRETON COAL MINES.

THE coal mines in the Cape Breton district of Nova Scotia, are rapidly adopting electricity for their motive power. A new turbine station is being built to generate 6,600 volts at 25 cycles. To prevent the power factor from falling below 80 per cent., some 600 horsepower synchronous motors driving air compressors are made to take a leading current by field adjustment. These motors are started as induction motors from auto-transformers with high-pressure oil switches having a large overload capacity.

A large hoist situated near the new generating station, handles 1,200 tons per ten-hour day, the haul being made on a 22.5 per cent. gradient 4,500 ft. long. The total gross weight of 30 cars per trip is 82,500 lbs. For this work, use is made of a direct-current motor mounted on the winding drum shaft and supplied with energy from a motor generator. This motor has an intermittent load rating of 1,600 horse-power, and operates normally at 50 revolutions per minute. In the near future, two more electrical coal hoists of the same character will be put

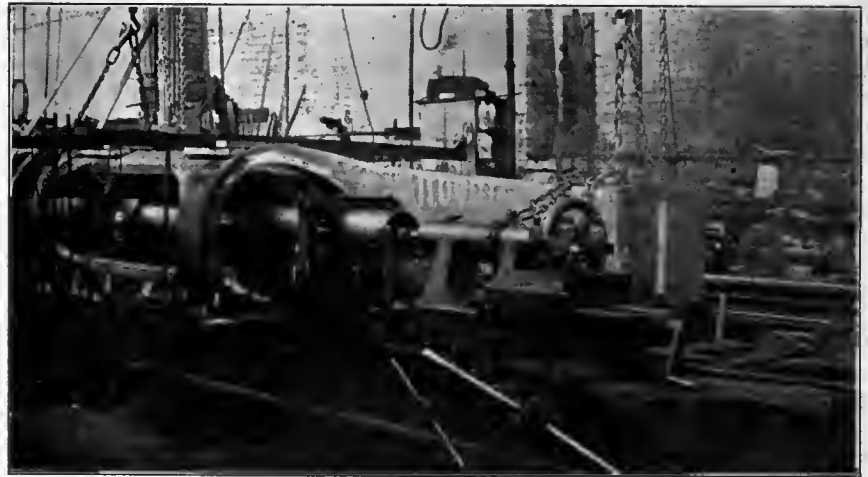

BORING OUT A LARGE CASTING.

blocks and securely bolted down to the lathe shears, after being first set up true with the boring bar. The overhang of the casting was of course supported from the shop floor by blocks. The boring bar had the usual sliding head fitted with a star wheel feed, and was carried between the lathe centres. While the cylindrical portion of the casting, measuring 24 inches in diameter by 72 inches long, was being bored, the bolt

in use, and will haul 24 cars up a 32 per cent. gradient at a maximum speed of 30ft. per second. The gross weight per car will be 2,900 lbs., and the length of the slope between 3,000 ft. and 5,000 ft., with an output of 1,200 tons in eight hours. In order to diminish the load at starting, the cars in this mine will not be started on the gradient, but from a level stretch of track laid at the working face of the mine.

FREEZING PROCESS IN FOUNDATION WORK.

A CASE has been recently reported of a successful application of the freezing process in the excavating of the foundations of a large building in Berlin. Here the excavation, owing to vault requirements, had to be carried down 10ft. below the foundations of the adjoining building on each side, which were on quicksand, and therefore would be undetermined if special precautions were not taken. A frozen wall around the new excavation was effected by artificial means, and 5in. freezing pipes, 3ft. apart and closed at the bottom, were sunk all round the proposed foundation pit. These pipes contained 1in. brine pipes open at the bottom. The latter were connected to a supply header at the top and the 5in. pipes to a drain header. The system was supplied from a brine pump in connection with a refrigerating plant. The brine passed down the 1in. pipes, up the 5in. pipes, and back into the drain header, which returned it to the brinetanks. The arrangement was found to be cheaper than if a pneumatic caisson had been employed.

SUN POWER.

AT the fourth ordinary general meeting of the Sun Power Co. (Eastern Hemisphere), held recently, Mr. Shuman mentioned that when the Cairo plant was first started it worked as easily as any steam engines did for the first few days, and the engineers were satisfied with the results. After three days, however, the zinc boilers, owing to the heat of the sun, softened. They could not stand the increased temperature, and consequently the plant had to be stopped. It was believed that a temperature 200 degrees higher was obtained in Egypt than in America. That, however, did not discourage them, although it was disappointing to lose time, for they knew that they could construct boilers which would take higher temperatures, so they put the plant in charge of an engineer and proceeded to construct cast iron boilers which would stand the heat. They expected to have those boilers put in by May 15th, and to have the plant in full running order by June 1st. In future, however, the boilers would be pressed out of a single piece of steel tubing. The reason why cast iron boilers had been installed was on account of the facility with which they could obtain them.

When the sun got to work on their reflectors at six in the morning they would have steam by 6.15. If they got the sun to work on water in the boilers at noon they would have steam in three minutes. A sun-power

plant could be built of any size from 25 horse-power up to 100-000 horse-power, or even larger. If they wanted more power, it merely meant covering a larger area. For every acre of ground covered they could obtain 250 horse-power, so that if they wanted 1,000 horse-power they would have to cover 4 acres, and so on.

THE CONSTRUCTION OF ENGINEERING WORKSHOPS.

A PAPER on the above subject was read recently before the Manchester Association of Engineers, by Mr. H. N. Allott, M. Inst. C.E. The author confined his paper chiefly to a description of an ordinary engineering shop of moderate size arranged all on one floor with small bays on one side for light tools and fitting, and wider and higher bays for heavier machine tools and erection purposes.

General Features.

The shop described lends itself to gradual extension in either direction. The heights of the buildings were 30ft. for the erecting and heavy machine shops and 15ft. for the light machine and fitting shops. The roofs of all the bays were of the ridge type. The widths of the bays, of course, depended on the machines employed and the character of the work to be carried out.

The author said that where matters could be arranged to suit a bay of not more than 25ft. in width, a saw-tooth roof was the best to adopt. If the bays were of a greater width than 25ft., the increased length of the glazing bars necessitated the use of a centre purlin and also increased the strength in the rafter back. The roof principals were arranged at right angles to the length of the shop, so that the shafting, heating, and lighting pipes might be conveniently carried from them. He described the various systems of roofing, and gave as his opinion that asphalt felt laid on thicknessed, grooved and tongued boarding formed the best covering for engineering workshops and similar buildings. Besides being cheaper than slating, it had the advantage of not being damaged by men walking on it to attend to skylights, etc. The use of such material of good quality is permitted by the building departments of most local authorities, although one or two treat it as not being sufficiently incombustible. With regard to glazing, he said the best systems of patent glazing consisted of a steel bar to which is fixed a lead flashing worked down on to the glass to form a weather-tight joint.

Roof Structure.

For roof principals steel angles, tees, and other rolled sections were advocated,

and for roofs of moderate span, say up to 50ft., economical spacing may be taken as from 10ft. to 12ft., which allows purlins of angle section to be employed. For roofs of larger spans, it is frequently more economical to space the roof principals further apart and to use purlins of channel, Z, or rolled joist sections. In cases where the crane loads and lengths of stanchions permit, cheap and convenient forms are provided by the use of rolled steel joists of suitable sections, with flat bars or steel channels riveted on to give additional flange area. The author said the section formed of a rolled steel joist and two channels was a very convenient one. With regard to the choice of girders to carry the roofing, the author said that, where the stanchions did not exceed 25ft. centres, a rolled steel joist was usually of sufficient strength. The depth for a working stress of 7 tons should not be less than one-eighteenth of the span. For spans of over 25ft., a lattice girder or plate girder will be required. The paper also dealt with means of carrying shafting, floor construction, etc.

In the discussion which followed the reading of the paper, the president, Mr. Charles Day, particularly emphasized the necessity for quick cranes in shops where it is not possible to arrange the work in strict progressive fashion. With regard to roofs, he advocated the saw-tooth type for all spans for country shops, with the saw tooth extending across the main span of the shop. One of the advantages of this type of roof, he said, was the ease with which the glass could be cleaned.

OXIDE OF ALUMINUM INSULATION

THE oxide which forms on aluminum is a good insulator, as is shown by the fact that field coils for tramway motors are being made up of bare aluminum wire. For this purpose the wire has a specially thick layer of oxide deposited on it by treatment with borax. The bath contains 50 parts alcohol, 60 parts of ammonia and 100 parts of water saturated with borax, and the temperature is kept at 50 to 80 deg. Cent., whilst a current of 0.05 amperes per square cm. surface of the coil is passed for about 15 minutes. After being washed and dried, the completed coil is taped round in the usual way, and it is of interest to note that the actual cross-section of the finished coil is no larger than a coil made of copper wire, although there are the same number of turns. One reason is that aluminum can be worked at a higher current density, and being a solid mass of metal, the heat gets away more readily. The temperature coefficient is about 10 per cent. less than for copper.



Toronto, Ont.—The Polson Iron Works Ltd., sued the Farmers Feed Co. for \$69.80. The claim was for work done and material supplied. The defendant Company stated that the material was not satisfactory and judgment was given in their favor, the judge holding that the plaintiff Company should have sent for the material complained of, and rectified the so-called mistake.

Toronto, Ont.—Nine hundred and sixty dollars damages were awarded the Canadian Carbon Co., of Toronto, against the Planiawerke Carbon Co., of Berlin, Germany, by Justice Lathford in Non-Jury Assize Court at the City Hall, recently. The Canadian firm claimed \$2,000, but the court did not consider that amount due.

Defendants admitted the claim, and it only remained for the judge to state the amount of damages. The Toronto firm contracted to purchase an assortment of arc light carbons from the German Company. When the shipment arrived, payment was required before delivery. Accordingly \$562.60 was paid the Berlin firm, beside \$144.32 freight and duty amounting to \$196.91. When the goods were examined they were found to be worthless, and the defendants refused to take them back.

Vancouver, B.C.—A sub-contractor who supplies labor to a contractor, or a sub-contractor who supplies material to a contractor, are both protected by the Mechanics' Lien Act, but a sub-contractor who supplies both labor and material to a contractor, instead of having twice as good a claim for a lien, has no claim at all. This is the gist of a surprising judgment handed down by the British Columbia Court of Appeal in the case of Fuller vs. Beach & Turner.

The suit in which this important decision was given, was brought by Mr. Fuller, a plasterer and sub-contractor, against Mr. Turner, the owner of a house on Fourth Avenue, and A. B. Beach, the principal contractor. Fuller had taken the plastering contract from Beach who, after drawing \$6,100 from the contract of \$8,500, left the job unfinished. Fuller's sub-contract was nearly completed, but as it cost Mr. Turner more than the balance of Beach's contract price to complete the house by day labor, he refused, to pay Fuller, and referred him to Beach for the money. After a trial of the issue before Judge Grant, his honor allowed Fuller's

claim for a lien on the building for the amount due on his sub-contract. The decision was appealed by the owner of the building with the above result. In giving his judgment, Chief Justice Maedonald said: "Our Mechanics' Lien Act does'nt afford a sub-contractor the protection provided by similar laws of other Provinces namely that a proportionate part of the contract price shall be retained by the owner at the peril of his paying twice, as a fund to which sub-contractors may resort to satisfy their liens. We have in this province what appears to me to be an anomaly, that while he who does work alone and he who supplies material alone are protected, he who does work and finds material to do his work is left to shift for himself."



THE SIMMONS MFG. CO.'S SAFETY PLAN.

A PLAN for increasing safety and promoting efficiency by the expenditure of approximately \$100,000 during the first year of its operation was announced at a dinner given recently by the Simmons Manufacturing Company, Kenosha, Wisconsin, one of the largest manufacturers of brass and iron beds in America, to 80 or more factory superintendents and foremen. C. W. Price, safety expert for the Industrial Commission, of Wisconsin, and formerly in charge of safety work for the McCormick works of the International Harvester Co., was one of the speakers. President Z. G. Simmons gave an address in which the safety plan was announced and outlined.

A board of efficiency selected from the list of factory superintendents and foremen, with Superintendent Rudd as chairman, will have charge of the distribution of the fund, and a prize of \$2,500 will be divided between the two foremen who show the greatest improvement towards safety and efficiency during 1913.



TRENTON CREOSOTING PLANT.

FORTY acres of land on the river front at Trenton, Ont., have been purchased by the Canada Creosoting Co., who will erect a large plant for creosoting timber of all kinds. The United States Wood Preserving Co., and the American Creosoting Co., jointly control the stock of the Canada Co., but about one-third of the stock will be held by Canadians. The head sales office of the new company will be at Montreal, where a tank station will be erected.

Creosoting oils will be brought to the Montreal station in tank steamers from

Europe, and a small tank steamer, specially constructed for going through the St. Lawrence River canals will carry the oil from the Montreal station to the Trenton plant. Mr. E. S. Clements, of the United States Wood Preserving Co. will be the Canadian manager, with headquarters at Montreal. President Hurt, will be the president of the Canadian Company.

The company will treat principally, railroad ties and wood paving blocks, by the vacuum pressure method. Approximately 150 men will be employed at the start. A plant costing in the neighborhood of \$200,000, with storage space for a million ties, will be erected at once. Enough ground has been purchased to treble the initial capacity of the Trenton plant, and it is thought that within a year the capital of the Canadian company may be greatly increased and the plant considerably enlarged. The Trenton plant will be practically a duplicate of the plant of the United States Wood Preserving Co., at Toledo, Ohio.



AN ENGINE BREAKDOWN.

IN the March issue of "Vulcan" some interesting illustrations are given of an engine breakdown, brought about by the failure of a cast iron crank. The engine, originally of the simple beam condensing type, was built as far back as 1856, being afterwards compounded by fixing a vertical high-pressure cylinder to the opposite end of the crank shaft. The high-pressure cylinder was 21in. diameter by 4ft. stroke, and the low-pressure 33in. diameter by 6ft. stroke. The engine ran at 36 revolutions per minute, and drove the load by means of gearing. It had worked under these conditions for many years, but a little while ago commenced to give trouble on the high-pressure side, owing, in all probability, to a change in alignment caused by yielding of the foundations, connections, etc., and eventually the cast iron crank broke suddenly through the crank pin eye, smashing the high-pressure cylinder and numerous other parts. The illustrations showed that the broken crank was weakened to a great extent by a cotter hole for receiving the crank pin cotter, and on examination after the breakdown the metal showed signs of fatigue and gradual fracture.



Prince Rupert, B.C.—The Canadian Fish and Cold Storage Co. is erecting a fertilizing plant. The company has a cold storage plant that cost about \$1,000,000.

MACHINE SHOP METHODS ^{AND} DEVICES

Unique Ways of Doing Things in the Machine Shop. Readers' Opinions Concerning Shop Practice. Data for Machinists. Contributions paid for.

BABBITTING FIXTURES.

By H. R.

THE accompanying sketches show two very simple methods of babbitting that have been successfully applied on the big end of connecting rods and caps; fig. 1 shows a connecting rod cap in position. The apparatus can also be used for the connecting rod, if set on a stand. It consists of a cast iron block

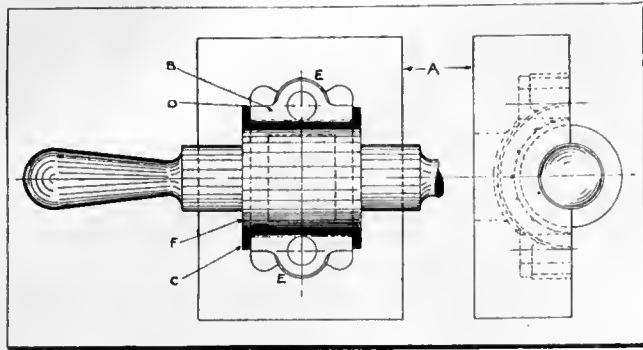

FIG. 1.—BABBITTING FIXTURES.

(A) shaped out to suit the form of the component (B) and the space for the babbitt (C). Location is secured by the sides (D) and the bosses (E). The bar (F), of mild steel, is turned to suit the bore of the connecting rod. To operate, pour a quantity of babbitt into the fixture and gradually work the bar (F) into place, it being essential that the two smaller diameters go to their proper

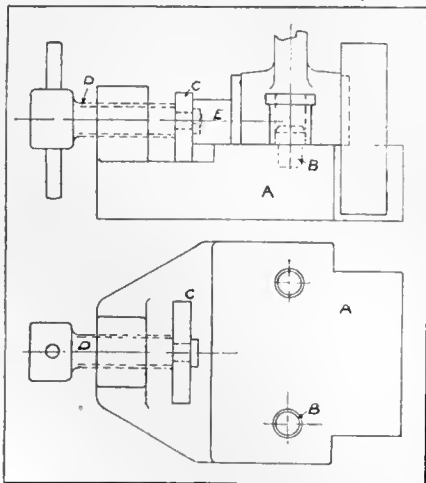

FIG. 3.—BABBITTING FIXTURES.

depth, so as to force the babbitt into its right form and remove all air. When nearly set, scrape level with a piece of sheet iron.

In fig. 2 is shown another method, which has proved better than the first, being, however, a little more expensive, and taking longer for the operation. It consists of a mild steel plate (A) which locates the connecting rod or cap for babbitting by the pins (B), these being turned to suit the bolt holes. A cylindrical portion is turned to the form and

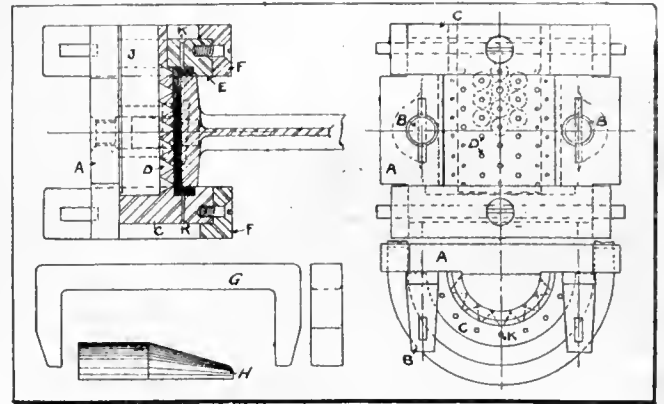

FIG. 2.—BABBITTING FIXTURES.

diameter required for the babbitt, this being afterwards halved as shown at (C). The holes (D) are next drilled and countersunk, while the top part (E) is turned to flange form and cut to secure a complete half. The straps (F), of mild steel, are screwed to the pieces (C) and (E). The various parts being cotted in position with the connecting rod, and held securely by two clamps (G), are then ready for the pouring operation. First get the fixture lukewarm, then fill up the recess (J) with babbitt and press into it the taper wedge (H). The metal is thereby forced through the holes (D), and the air escapes through the numerous vents (K). After the babbitt has set, knock the clamps and cotters away, leaving the half cylinder (C) intact.

The fixture shown in fig. 3 for shearing the cylinder from the rod without distorting the metal consists of a cast iron base (A) into which are pressed the pegs (B). By putting the connecting rod on to these pegs and applying pressure by the screw (D) to the plate (C), the cylinder (E) can be easily sheared clear from the connecting rod without distortion. The cylinder can then be cleared of its metal by simply putting it into the metal pot for a few seconds.

CHAMFERING A LOT OF SPECIAL SCREWS.

By D. A. Hampson.

THROUGH a mistake on the part of a screw machine house, we received 10,000 of the special screws which the drawing shows, but lacking the chamfer or bevel on the thread end. It was up to

the writer to have this produced in the cheapest way and how it was done is shown by the drawings. It will be observed that the screws were left hard and that they had right angle slots in the head; both of these features were in our favor.

A block of cold rolled steel $\frac{1}{2} \times 1\frac{1}{2}$ was secured and a slot milled across it the size of the screw slot. In this milled slot was pressed a piece of tool steel-

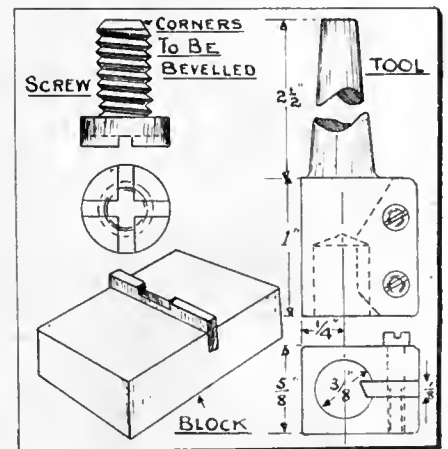

CHAMFERING A QUANTITY OF SPECIAL SET SCREWS.

tempered to a purple—with a notch in the centre the length of the screw head diameter. This notch portion projected above the C.R.S. block about half the

depth of the screw slot. The block was clamped to the table of a sensitive drill and the screws were placed, head down, over the notch. Thus one quick, simple operation located the screw and prevented it from turning.

The chamfering tool was cut from a piece of $\frac{5}{8}$ x 1 steel, slotted as shown and fitted with a cutting tool, having the correct bevel. This tool was held in the chuck and brought down over the work. The machine was left running all the time and a boy did the work. It will be noticed that the tool centres itself on the work before the cutting position is reached.



TOOL FOR REMOVING BROKEN SET PINS.

By W. T. Gavin.

It is often a very difficult matter to remove a broken set pin, and more especially if it happens to break below the surface of the metal into which it is screwed. The usual method of removing broken set pins by means of a centre punch is always open to objection. In the first place, it is a very easy matter (however careful one may be) to damage the thread in the screwed hole, or swell the outside of the set screw thread and thus further lock it, the latter being due to having to strike the screw as near the outside as possible in order to obtain a leverage to move it. This trouble is perhaps not so great with large screws as they are generally more accessible, but with screws of small diameter it becomes quite a different proposition.

The tool here described is of simple construction and can be made throughout by hand. Simple though it may be, however, in order to obtain best results, everything depends upon it being carefully hardened and tempered. Fig. 1 is a general view of tool, Fig. 2 shows

method of using tool, and Fig. 3 shows method of removing broken screw. To remove a broken screw, the procedure is as follows:

First drill a hole in the screw (as large as possible), and then drive the square pointed end of the punch into the hole by means of a few gentle taps until it grips the screw, now turn the punch

as a driving means between the two parts.



A DRILLING JIG.

By R. H. M.

THE sketch shows a jig for drilling the serewed end of pins, into which pass cotter split pins. It is machined

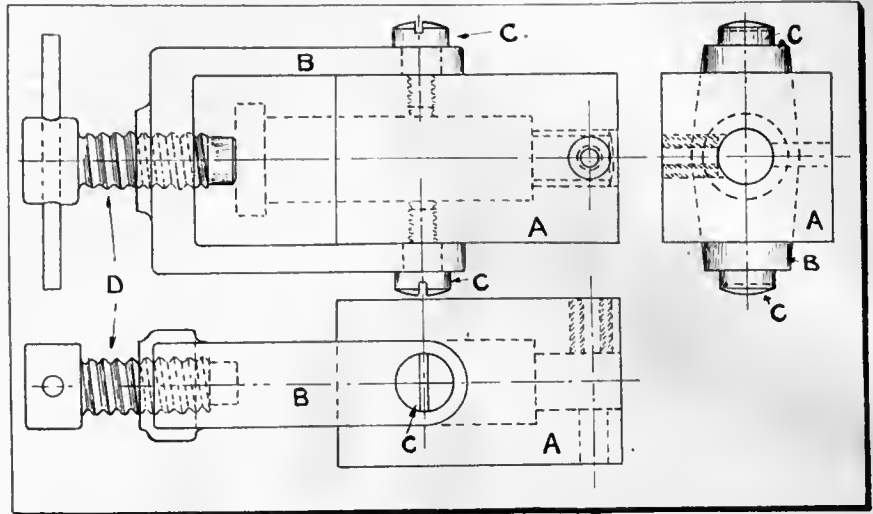

A DRILLING JIG.

by means of a hand carrier, and it will be found that the screw turns with it, this being due to the fact that the punch being square pointed tends to make the hole conform to its shape, and thus acts

from a stock piece of square cast iron (A). This is drilled to suit the pin and afterwards ground. It is clear of the serewed end of the pin where the hole has to be drilled. The strap (B) is a forging and swings on the pivots (C) which are screwed into the casting (A). This strap is threaded to take the screw (D). The operation of drilling is as follows:

The pin is slipped into the jig and pushed up to the locating shoulder by the screw (D), burring the thread and making it hard of removal. By swinging the strap over and putting the screw (D) on to the pin point, it can be readily moved or withdrawn. In designing a jig of this type it must be clearly understood that the pivots (C) are central between the end of the pin and far end of the jig.



THE EASTERN CAR CO. PLANT.

THE plant of the Eastern Car Co., at New Glasgow, Nova Scotia, is rapidly nearing completion. The power house is practically finished. Most of the machinery being installed. The power plant will start operation in about 30 days. The main building, which is 1,100 ft. long, of four spans, each 90 ft. wide, is getting under roof, and much of the machinery is on the ground. From present indications, the company will be fabricating car material within 60 days.

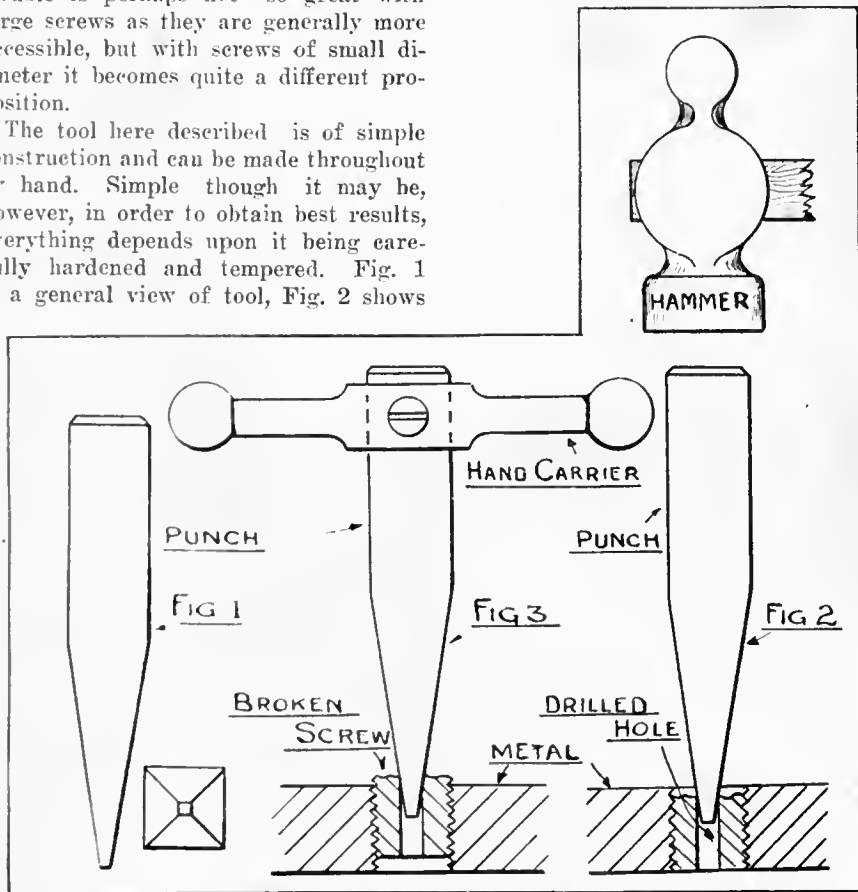

TOOL FOR REMOVING BROKEN SET PINS.

DEVELOPMENTS IN MACHINERY

A Record of New and Improved Machinery Tending Towards Higher Quality and Economical Production in the Machine Shop, Blacksmith Shop or Planing Mill.

TROLLEY FOR ELECTRIC TRAVELLING CRANES.

THE illustrations accompanying this article show the construction of the new design of inside and enclosed gearing trolley manufactured by the Whiting Foundry Equipment Co., Harvey, Ill. The capacity of the trolley shown is 10 tons. All gears are inside the main bearings, absolutely preventing

ing on this trolley. When used with dynamic braking the mechanical brake is omitted. Trolley travel gearing is in two reductions from motor to trolley axle. All gear cases are cast iron, with horizontal machined joints, and liberal opening is provided in each case for inspection and lubrication. The shaft boxes are all integral with truck castings, and caps are all matched, and in-

trucks, which are connected by means of a separator casting, all surfaces fitting together being machined. Each end of the separator rests on a ledge extending from the trolley side, thereby eliminating all shear on connecting bolts. This is a regular feature of the Whiting trolley. A large platform is provided for mounting motors and operating mechanism, and permits of the attendant inspecting the operation with the greatest facility.

The simplicity of the wiring is notable. Holes in the trolley separator are provided, and wires lead directly from the motors to the collector brackets attached to poles supported below the trolley frame. A limit switch, operated by the block itself, is furnished in connection with the hoisting mechanism.

It is claimed that this trolley, which is made in a wide range of capacities, is the most accessible of the completely enclosed gearing trolleys on the market. Modifications in construction are made to meet special conditions of customers and requirements of mill service.

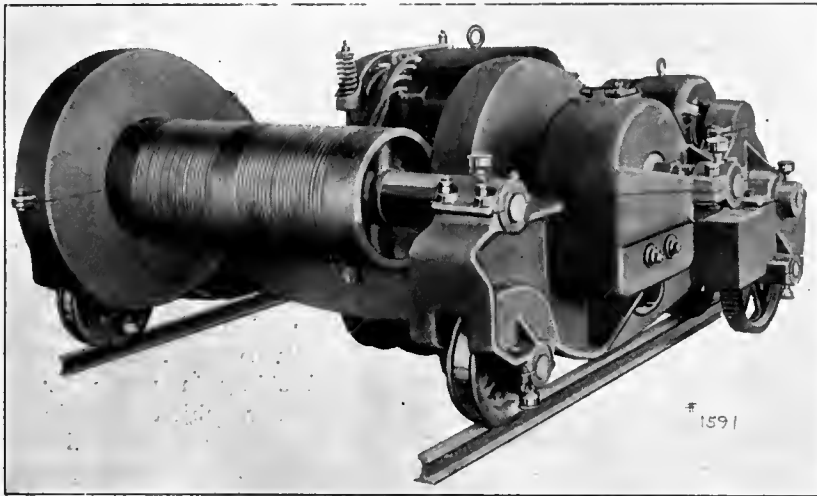

TROLLEY FOR ELECTRIC TRAVELLING CRANES.

thereby gears working off the shaft and falling below.

The trolley trucks are of I-beam section. Bolts for holding on caps extend through the flanges. The mechanical brake of the hoisting mechanism is contained in a pocket in the truck. Necessary adjustments can be made without removing cover.

There are only two reductions of gear-

terchangeable for drum and intermediate shafts. All bearings are of cast iron, with babbitted shells, except the axle bearings, which are bronze. The bearings are machined to gauges, turned on outside and fitted into bored boxes. Large bosses prevent turning, while ample lubrication is furnished by grease caps.

The trolley frame consists of two cast

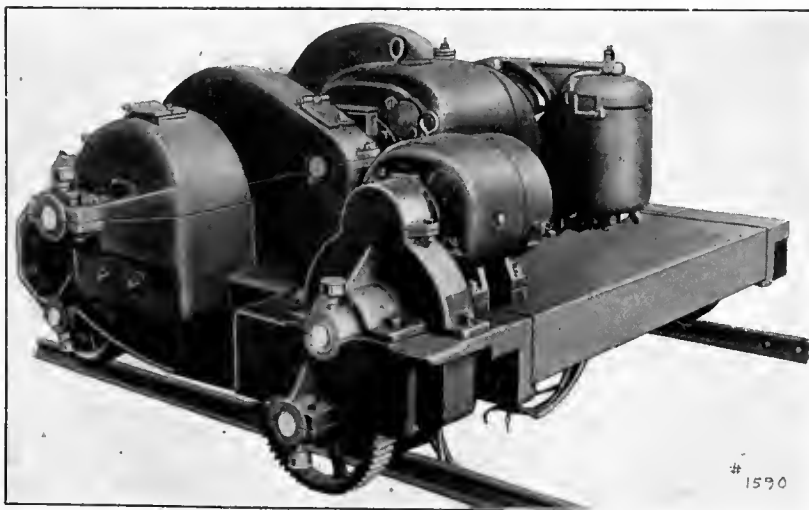

TROLLEY FOR ELECTRIC TRAVELLING CRANES.

NEW MODEL PLAIN MILLING MACHINE.

THE machine illustrated herewith is manufactured by the Oesterlein Machine Co., Cincinnati, Ohio, and is known as their No. 20 New Model Plain Milling Machine. It is identical with the firm's No. 20 model, except for the saddle feature.

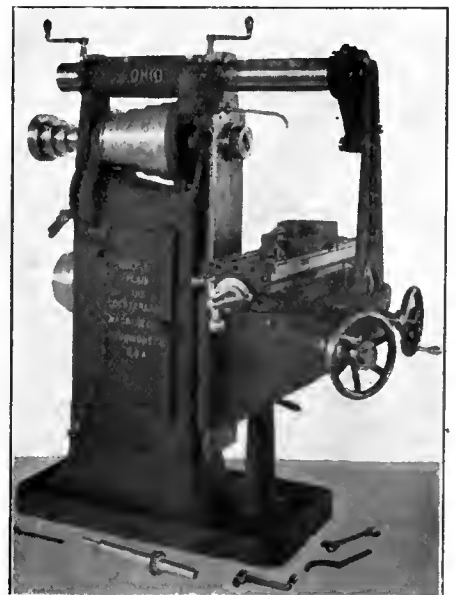

NEW MODEL PLAIN MILLING MACHINE.

The back gear is placed inside the column below the spindle, and the improved type cone with increased belt contact is fitted. The arbor is driven with a clutch in front of the spindle and the spindle nose made a duplicate of the larger sizes, namely the Nos. 24 and 28 plain and No. 25 universal, as well as the No. 20 universal, so that tools and cutters are interchangeable. The column is provided with oil wells for lubricating the spindle, and the knee is locked with taper sliding gib clamping along the entire face of column, being operated with a single lever. Hand wheels are provided for cross and vertical adjustment.

BORING AND FACING SPRING SHACKLES.

By H. R.

THE drawing shows a method of boring and facing spring shackles, which produces a very satisfactory job. The face plate (A) is a casting machined and screwed to suit the nose of the lathe. It carries the cast iron slide (B) in the vee, and is secured in place by the steel strip (C). Into the plate (A) are pressed the two locating bushes (D), while a similar bush is pressed into the slide (B). This slide (B) accommodates the jaws (E) by the vees (F) and the projecting pieces (G). These jaws, of machinery steel, machined all over and case-hardened after screwing, are operated through the screw (H), which has a right and left hand Acme thread, 8 to the inch, which allows for a fine adjustment and a sure grip.

It will be noticed that there are two squares—one at each end. These provide convenient adjustment, independent of the position of the jig. Out of the centre portion of the screw (H) are turned the collars (I), and between these are two semi-circular bushes (J),

screwed at each end, these being made of sufficient diameter to allow the lock nuts (K) to pass clear of the Acme threads. The bracket (L) is put in position and held there by the lock nuts. When the jaws have been screwed into place and centred correctly, the bracket is swung in the slot and held securely by the nut (M).

The operation is performed by placing the outside flanges of the shackle to be bored between the jaws. After tightening the latter, the plates (N) are screwed down firmly. This takes all the strain developed by the boring tool off the vees (F), and makes, as it were, one whole solid fixture. The locating plug is next put in position, and the nuts (O) screwed down on to the strip (C), thus taking all strain off the plug. One hole is now bored, faced and reamed, the nuts being afterwards loosened and the slide moved along to the other position for a similar operation. When shackles are made of two different diameters, it will be necessary to make one jaw to suit the smaller diameter.

ENGINEERING CONVENTION.

NOTED railway engineers and prominent officials from all parts of Canada and the United States attended the annual convention of the American Railway Engineering Association, held in Chicago at the Congress Hotel, March 18-21. In addition to the election of officers and other routine business, reports were read and discussed on such topics as railway rules and organization, signals and interlocking, iron and steel structures, rails, the economies of railway location, wooden bridges and trestles, wood preservation, ties, masonry, the conservation of natural resources, ballast, water service, yards

and terminals, electricity, records, and accounts. On Tuesday evening, March 18, a reception was given to members of the association and their guests in the Gold Room of the Congress Hotel. Among the Grand Trunk representatives in attendance at the convention were Messrs. H. R. Safford, chief engineer; Wm. McNab, principal assistant engineer; A. S. Going, construction engineer; M. S. Blaiklock, engineer of maintenance of way; R. Armour, masonry engineer; R. F. Morkill, signal engineer; P. B. Roberts, chief of the drafting room; J. R. W. Ambrose, engineer of grade separation; H. B. Stuart, structural engineer; J. B. Gaut, structural engineer, and a large number of the divisional and resident engineers, bridge and building superintendents, and general roadmasters.

"A Little Journey to the Home of the Economy Turbine," written by Elbert Hubbard as the result of his visit to the works of the Kerr Turbine Co., Wellsville, N.Y., includes an interesting discussion of steam economy from the time of James Watt to the present. Mr. Hubbard has displayed such unusual ability in making interesting reading of a subject generally termed "dry," that when one engineer reads this booklet, he wants everybody in the plant to read it. The Kerr Turbine Company will send a copy on request.

WORM GEARING DATA.

By E. W. Tate.

THE tables published herewith, although not novel, will be found to be very useful as time savers. They were computed for use when time is limited. The writer has not previously seen any such tables in print.

To obtain the pitch or throat diameter of any worm gear, multiply the tabulated diameters for the required number of teeth by the required circular pitch.

As the outside diameter of a worm gear varies as do the face and face angle no attempt has been made to tabulate the outside diameter.

Example:—Required the pitch diameter of a 32 tooth worm gear of 1-3 inch circular pitch.

From the table the diameter for a 32 tooth gear will be found to be 10.1856, which multiplied by 1-3 will give 3.3952, the required diameter.

Example:—Required the centre distance of a 40 tooth worm gear and a worm of $1\frac{3}{4}$ inch outside diameter, of 1-5 inch circular pitch.

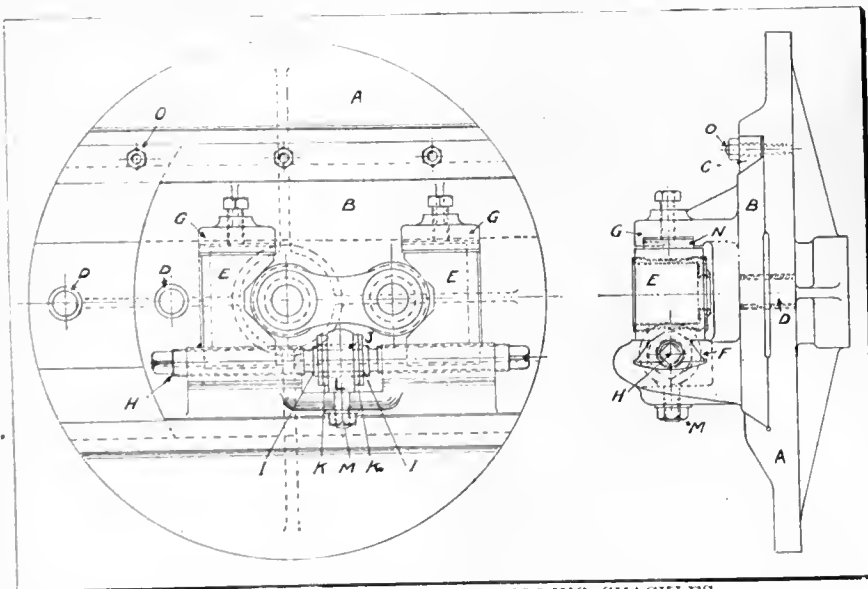

BORING AND FACING SPRING SHACKLES.

From the gear table, the pitch diameter for 40 teeth is seen to be 12.7320, From the worm table, 1-5 inch circular pitch, the pitch diameter of 1 3/4 inch diameter worm is found to be 1.624 inch.

$$12.7320 \times 1.5 \text{ in.} = 2.5464.$$

$$1.624 \text{ (pitch diameter of worm)} + 2.5464 = 4.1704.$$

4.1704 divided by 2 = 2.0852, the centre distance.

In the table of worms, the root diameter (R.D.) is given so that the amount of metal below the tooth may be ascertained at a glance.

In the accompanying tables the following abbreviations are used:—P.D. for pitch diameter; T.D. for throat diameter; O.D. for outside diameter, and R.D. for root diameter, or diameter at bottom of thread.

Worm Gears, 1 Inch Circular Pitch.

TEETH.	P.D.	T.D.
30	9.5490	10.1850
31	9.8473	10.5039
32	10.1856	10.8222
33	10.5039	11.1405
34	10.8222	11.4588
35	11.1405	11.7771
36	11.4588	12.0954
37	11.7771	12.4137
38	12.0954	12.7320
39	12.4137	13.0503
40	12.7320	13.3686
41	13.0503	13.6869
42	13.3686	14.0052
43	13.6869	14.3235
44	14.0052	14.6418
45	14.3235	14.9601
46	14.6418	15.2784
47	14.9601	15.5967
48	15.2784	15.9150
49	15.5967	16.2333
50	15.9150	16.5516
51	16.2333	16.8699
52	16.5516	17.1882
53	16.8699	17.5065
54	17.1882	17.8248
55	17.5065	18.1431
56	17.8248	18.4614
57	18.1431	18.7797
58	18.4614	19.0980
59	18.7797	19.4163
60	19.0980	19.7346
61	19.4163	20.0529
62	19.7346	20.3712
63	20.0529	20.6895
64	20.3712	21.0078
65	20.6895	21.3261
66	21.0078	21.6444
67	21.3261	21.9627
68	21.6444	22.2810
69	21.9627	22.5993
70	22.2810	22.9176
71	22.5993	23.2359
72	22.9176	23.5542
73	23.2359	23.8725
74	23.5542	24.1908
75	23.8725	24.5091
76	24.1908	24.8274
77	24.5091	25.1457
78	24.8274	25.4640
79	25.1457	25.7823
80	25.4640	26.1006
81	25.7823	26.4189
82	26.1006	26.7372
83	26.4189	27.0555
84	26.7372	27.3738
85	27.0555	27.6921
86	27.3738	28.0104
87	27.6921	28.3287
88	28.0104	28.6470
89	28.3287	28.9653
90	28.6470	29.2836
91	28.9653	29.6019
92	29.2836	29.9202
93	29.6019	30.2385
94	29.9202	30.5568
95	30.2385	30.8751
96	30.5568	31.1934
97	30.8751	31.5117
98	31.1934	31.8300
99	31.5117	32.1483
100	31.8300	32.4666
101	32.1483	32.7849
102	32.4666	33.1032
103	32.7849	33.4215
104	33.1032	33.7398
105	33.4215	34.0581
106	33.7398	34.3764
107	34.0581	34.6947
108	34.3764	35.0130

TEETH.	P.D.	T.D.	O.D.	P.D.	R.D.
109	34.6947	35.3313	2 3/4	2.538	2.292
110	35.0130	35.6596	2 1/2	2.288	2.042
111	35.3313	35.9679	2 1/4	2.038	1.792
112	35.6596	36.2862	2	1.788	1.542
113	35.9679	36.6045	1 7/8	1.663	1.417
114	36.2862	36.9228	1 3/4	1.538	1.292
115	36.6045	37.2411	1 1/2	1.413	1.167
116	36.9228	37.5594	1 1/4	1.288	1.042
117	37.2411	37.8777	1 3/8	1.163	0.917
118	37.5594	38.1960	1 1/4	1.038	0.792
119	37.8777	38.5143			
120	38.1960	38.8326			
121	38.5143	39.1509			
122	38.8326	39.4692			
123	39.1509	39.7875			
124	39.4692	40.1058			
125	39.7875	40.4241			
126	40.1058	40.7424			
127	40.4241	41.0607			
128	40.7424	41.3790			
129	41.0607	41.6973			
130	41.3790	42.0156			
131	41.6973	42.3339			
132	42.0156	42.6522			
133	42.3339	42.9705			
134	42.6522	43.2888			
135	42.9705	43.6071			
136	43.2888	43.9254			
137	43.6071	44.2437			
138	43.9254	44.5620			
139	44.2437	44.8803			
140	44.5620	45.1986			
141	44.8803	45.5169			
142	45.1986	45.8352			
143	45.5169	46.1535			
144	45.8352	46.4718			
145	46.1535	46.7901			
146	46.4718	47.1084			
147	46.7901	47.4267			
148	47.1084	47.7450			
149	47.4267	48.0633			
150	47.7450	48.3816			

1/2 Inch Circular Pitch.

O.D.	P.D.	R.D.
6	5.682	5.314
5 3/4	5.432	4.904
5 1/2	5.182	4.514
5 3/4	4.932	4.124
5	4.682	3.734
4 3/4	4.432	3.344
4 1/2	4.182	2.954
4 3/4	3.932	2.564
4	3.682	2.174
3 3/4	3.432	1.784
3 1/2	3.182	1.394
3 3/4	2.932	1.004
3	2.682	0.614

5/8 Inch Circular Pitch.

O.D.	P.D.	R.D.
8	7.603	7.142
7 3/4	7.353	6.892
7 1/2	7.103	6.642
7 3/4	6.853	6.392
7	6.603	6.142
6 3/4	6.353	5.892
6 1/2	6.103	5.642
6 3/4	5.853	5.392
6	5.603	5.142
5 3/4	5.353	4.892
5 1/2	5.103	4.642
5 3/4	4.853	4.392
5	4.603	4.142
4 3/4	4.353	3.892
4 1/2	4.103	3.642
4 3/4	3.853	3.392
4	3.603	3.142
3 3/4	3.353	2.892
3 1/2	3.103	2.642
3 3/4	2.853	2.392
3	2.603	2.142

3/4 Inch Circular Pitch.

O.D.	P.D.	R.D.
10	9.526	8.974
9 3/4	9.276	8.724
9 1/2	9.026	8.474
9 3/4	8.776	8.224
9	8.526	7.974
8 3/4	8.276	7.724
8 1/2	8.026	7.474
8 3/4	7.776	7.224
8	7.526	6.974
7 3/4	7.276	6.724
7 1/2	7.026	6.474
7 3/4	6.776	6.224
7	6.526	5.974
6 3/4	6.276	5.724
6 1/2	6.026	5.474
6 3/4	5.776	5.224
6	5.526	4.974
5 3/4	5.276	4.724
5 1/2	5.026	4.474
5 3/4	4.776	4.224
5	4.526	3.974
4 3/4	4.276	3.724
4 1/2	4.026	3.474
4 3/4	3.776	3.224
4	3.526	2.974
3 3/4	3.276	2.724
3 1/2	3.026	2.474
3 3/4	2.776	2.224
3	2.526	1.974

1-5 Inch Circular Pitch.

O.D.	P.D.	R.D.
2 1/2	2.374	2.276
2 3/4	2.249	2.151
2 1/2	2.124	2.026
2 1/8	1.999	1.901
2	1.874	1.776
1 7/8	1.749	1.651
1 3/4	1.624	1.526
1 5/8	1.499	1.401
1 1/2	1.374	1.276
1 3/8	1.249	1.151
1 1/4	1.124	1.026
1 1/8	0.999	0.901
1	0.874	0.776

1/4 Inch Circular Pitch.

O.D.	P.D.	R.D.
3	2.841	2.658
2 3/4	2.591	2.408
2 1/2	2.341	2.158
2 1/4	2.091	1.908
2	1.841	1.658
1 3/4	1.716	1.533
1 1/2	1.591	1.408
1 3/8	1.466	1.283
1 1/2	1.341	1.158
1 1/8	1.216	1.033
1 1/4	1.091	0.908
1 1/8	0.966	0.783
1	0.841	0.658

1 Inch Circular Pitch.

O.D.	P.D.	R.D.
10	9.364	8.627
9 3/4	9.114	8.377
9 1/2	8.864	8.127
9 3/4	8.614	7.877
9	8.364	7.627
8 3/4	8.114	7.377
8 1/2	7.864	7.127
8 3/4	7.614	6.877
8	7.364	6.627
7 3/4	7.114	6.377
7 1/2	6.864	6.127
7 3/4	6.614	5.877
7	6.364	5.627
6 3/4	6.114	5.377
6 1/2	5.864	5.127
6 3/4	5.614	4.877
6	5.364	4.627
5 3/4	5.114	4.377
5 1/2	4.864	4.127
5 3/4	4.614	3.877
5	4.364	3.627
4 3/4	4.114	3.377
4 1/2	3.864	3.127
4 3/4	3.614	2.877
4	3.364	2.627

Worms.

1-3 Inch Circular Pitch.

O.D.	P.D.	R.D.
4	3.788	3.542
3 3/4	3.538	3.292
3 1/2	3.288	3.042
3 3/4	3.038	2.792
3	2.788	2.542

FOUNDRY PRACTICE AND EQUIPMENT

Practical Articles for Canadian Foundrymen and Pattern Makers, and
News of Foundrymen's and Allied Associations. Contributions Invited.

CUPOLA FEATURES.

WHEN choosing a cupola, says a writer in the "Giesserei Zeitung," attention should be paid first of all to its size, based on the annual product and, of course, through that, on the daily output. Cupola capacity should never be figured below 4,400 lbs. per hour, and never above 22,000 lbs. per hour. Small cupolas have the disadvantage that they are hard to repair, and that large castings can only be made with great difficulty. Cupolas over a capacity of 22,000 lbs. are not economical because they use too much coke, and tend to allow the different charges to fuse together prematurely.

Number and Capacity.

The melting time for commercial casting foundries should never be more than three hours per day. Shorter melting hours mean larger cupolas, and where foundries need more than 22,000 lbs. iron capacity, the best way is to set up two or more, and connect them by a common forehearth. Such an arrangement combines the advantages of a cupola of medium capacity with that of labor-saving. Only one man is necessary for tapping, and the charging of the two cupolas can be done by the shift usually necessary for one. An added advantage is that such a "set" of cupolas can be utilized singly as well as together, and on a day when only small quantities of iron are required, one of the two may be operated. If, for example, one is of 8,800 lbs. capacity, and the other of 11,000 lbs. per hour capacity, there are really three different capacities at command: namely, 8,800 lbs., 11,000 lbs., and 19,800 lbs., the latter, when both cupolas are operated. The installation costs are much lower than if three cupolas of the respective capacities were to be installed, and the repair costs are also low, as the cupolas are not attacked very much by the quick melting time. In large foundries, this plan can be expanded by equipping three cupolas with one common fore-hearth, or else by having two sets of cupolas, consisting of two furnaces each.

There are a number of foundries, however, whose output does not exceed 2,200 to 3,000 lbs. per day, these, therefore, must arrange their work so as to accumulate moulds for several days and then pour castings only two or three times a week.

Coke Consumption.

The coke consumption is practically

the same in all cupolas and totals about 9 to 12 per cent. of the weight of the iron charge, depending on the length of the melting time. There are quite a few foundry firms who praise their own make of cupolas and laud their low coke consumption, which they place at 5 to 6 per cent. of the iron charge. They usually explain this extraordinary result by the peculiar shape or position of the tuyers. In reality, however, it is due to the proper manipulation of the operating time and method, the short melting period and other tricks that may be applied to any cupola.

Installing Cupolas.

The following nine points should be kept in mind when installing new cupolas:—

The cupolas must deliver a hot iron mass without excessive heating, but thoroughly fused.

The several charges must not fuse with each other prematurely—i.e., several charges should not drop at the same time.

The cupola must have a low iron loss and the analysis of the iron poured into the moulds must show the required composition.

The furnace should be capable of melting cheaper grades of iron and give a good plastic charge.

The blast could not demand too much power to fulfill the required demand.

The tuyers should not slag or stop up.

The furnace must melt down uniformly and not hang.

The furnace should not be constructed too weakly and must have a sufficiently strong covering. All cast-iron parts liable to crack must be reinforced by wrought-iron bands.

The furnace must be in a position to be easily approached and must be capable of rapid and efficient charging.

Deep Melting Zone.

The above conditions are met by a cupola with a deep melting zone by which a good hot iron of the right temperature can be obtained without any trouble. If the iron is too hot, it has the tendency on tapping and coming in contact with the air to spatter all around, resulting in loss and personal injuries. This phenomenon which is nothing but an oxidation process, and increases with the decrease of carbon in iron, is entirely avoided by having a

deep melting zone. Another means of obtaining good castings is by the use of more coke and a greater blast, when melting iron which fuses with difficulty. The fusing temperatures of the various iron grades used in cupolas vary as much as 100 deg. C. and it is necessary for the foreman to know the temperature at which the charge melts in order to obtain satisfactory results. In judging the state of the fluid iron, many men trust to the eye. It is of course much better to use an optical pyrometer. A less accurate but still permissible method is to tap a small known quantity of fused iron into a deep vessel filled with water. The difference in temperature before and after the process will give the desired information as to the temperature of the iron.

The second point of importance is the prevention of mixing of charges prematurely, which can only be done by not allowing the melting zone to reach too great a height. A melting zone of 40 in. is too high for a medium size furnace, and the result will be that at least three charges will melt at the same time and give a very poor iron. The melting zone should be kept within limits by varying the blast.

Low Waste of Iron.

The third point, that of a low iron waste, or loss in the melting process, is of great importance. It often happens that foundrymen look only at the supposedly lower coke consumption, with a correspondingly higher iron waste. A foundry producing 3,000 tons of iron per year gains, with a saving of 1 per cent. of coke, 30 tons of coke, and with a saving of 1 per cent. iron loses 30 tons of iron. If we add that a lower coke consumption increases the danger of too low a carbon content in the iron, it is plain that it is better to add a few more tons of coke and have the assurance of a low iron loss.

Charging and Blast.

The greatest danger is the burning of the carbon and the direct burning of the metallic iron. The greater the danger zone in any cupola, the greater are the chances for loss of metallic iron. Melting zones should be large and great care taken that new charges are applied to the centre of the furnaces and not towards the sides. This can be done by making the diameter of the head smaller than the melting zone diameter. The

light coke will usually be pushed towards the sides of the cupola with the addition of new charges and will prevent the iron from collecting near the tuyers, and choking them.

The blast is furnished by blowers which can have either belt drive or electric motor drive. In the latter case, motor and blower may be direct shaft-coupled or else driven by gearing. Both methods have their drawbacks. The shaft coupling demands an expensive slow-running motor which must be regulated according to the revolutions of the blower. This, however, is a difficult matter with alternating current motors, as their number of revolutions is governed by the number of poles. Gear drives can be regulated much easier in this respect, but this drive is very noisy and the bed plates must be very heavy and accurately fitted to get efficient results. The simplest and best blower drive is the belt drive.

Planning Air Conduits.

In planning air conduits for the blasts between blower and cupola, care should be taken to avoid laying pipes at right angles to each other. Many foundries have their air conduits in a tangential position to the cupola. This should be avoided by all means. The air entering on a tangent must then change its direction to enter the tuyers and the centrifugal forces which are set up by this movement, in considerable degree, are hard to overcome. The result is loss of power and an impulsive, jerky action of the blower. The humming noise heard in so many cupolas can also be traced to this cause. Underground air conduits, if used at all, should have enamelled air pipes so as to avoid rusting.

Slagging of Cupolas.

The slagging of cupolas, as also the removal of the slag, is often the cause of much trouble. In many foundries the slag is dumped into a temporary pit near the cupola, and gives a good deal of trouble, besides being in everybody's way. With a cupola having a fore-hearth, the remedy is simple. A small iron industrial car can be drawn in front of the hearth, and the slag emptied into this, or else the slag can be left in the forehearth until enough has collected to empty it into a large ladle and remove it by means of a crane.

Cupolas without a fore-hearth have a bigger problem to deal with. The slag hole usually faces the back of the cupola and foundry, where conveying conveniences are not so handy. In this case it would be best to keep some sort of cast-iron vessel or ladle, holding about 200 pounds, near the cupola and empty the slag into this and have two men remove it when filled.

Many foundries have their cupola

room filled with fine slag wool. This is formed when the air from the blast and slag escapes at the same time, and is more common in cupolas without fore-hearth than in those with fore-hearth. These fine particles penetrate the respiratory organs of the workmen and cause irritation and inflammation.

To avoid this nuisance, all that is needed to shut off the blast during slagging, or, if this loss of time in melting is undesirable, have an upper and lower slag hole. The upper one is used when large quantities of iron are in the furnace, and the lower on normal occasions.

Storage of Supplies.

Raw material for cupola melting can be divided into iron, coke, and lime, and may be brought to the foundry either by rail or water. There should be a proper storage place for the pig iron. All iron should be stored in separate stock-rooms and the different grades or aggregates kept separate so as to avoid confusion and needless delay in mixing charges.

Charging of Cupolas.

The proportioning of the charges should be done near the cupola. The various materials should be piled separately, weighed, and then brought to the charging platform. The best method is to instal a small overhead telfer line on the charging platform, and to charge the various materials from buckets or else from rails, using a small tilting car. With such assistance, three men could easily charge 88,000 pounds of material into the furnace in one day.

Automatic charging of cupola by electric telfer line should, however, be avoided in small foundries. This is especially true for those with cupolas below 8-ton capacity. Such a system requires one man to watch the charges, and as this man would be needed, even without the automatic system, to control the charge or burden, nothing is gained. With larger cupolas the case is of course different. Here the automatic charging system is properly in place, as there is no danger of "hanging" the charge, and expenses can be reduced by the smaller number of men needed when using such an automatic system.

Coke Storage.

Coke should be stored in some place near the charging platform. In smaller plants it can be brought to the cupola in the same conveyors as used for the iron, but in larger foundries it will be better to use a separate bucket-conveying system.

Charging Platform Floor.

The next question is that of the flooring of the charging platform, and the cupola plant in general. For the latter, grilled cast-iron plates are best. These can be cemented to the floor beams and then a covering of loam can be spread

on top and tamped flat and solid. Such a floor is almost indestructible, and can be easily cleaned, and is not affected by slag and iron. Cement floors should be avoided. The liquid iron will crack the surface layer of the cement. The same objection applies to a tile floor.

The best plan is to use a 2-in. wooden floor for the charging platform and cover its surface with sheet iron. The girders and beams below this wooden floor should be incased in concrete. Cast-iron plates, if cast in proper moulds, are good, but too expensive. If cast in open sand they are too uneven and are liable to buckle on the edges and trip up the men or at least hinder transportation of material.

Ventilation Feature.

Finally, a few words may be said about the foundry smoke and gas problem. Most foundries use heavy spark chambers on their furnaces, and obtain through the resulting escape a cooling effect of the waste gases, so that the chimney on top of the spark chamber gives forth no flames or sparks.

These spark chambers are, however, often the causes of explosions and gas poisoning. The explosions occur if the chimney above the spark chamber is too low or too narrow, and if the furnace generates too much carbon monoxide and dioxide. An explosive mixture is thus produced in the spark chamber, and it may be suddenly ignited by a spark, and explode with some violence. The gas issuing from the throat opening is liable to burn the workmen, and the latter protect themselves against this accident by bringing the top flame to the ignition point.

A more difficult task is to protect against the escape of gases. It has been found that the air around the cupolas provided with chimneys is the purest and best. In cold weather, the air on the charging platforms of cupolas provided with spark chambers is, however, very disagreeable. This annoyance is easily explained. The exhaust gases from the cupola contain some nitrogen and carbon dioxide. The gases rise slowly due to the action of the spark chamber, and the carbon dioxide especially is considerably cooled, and being heavier than the surrounding air, sinks through the ventilation skylights of the roof over the charging platform.

The approved practice is to have the chimney high enough above the cupola building to give the gases opportunity enough to mix with the outside air. Another better plan is to install a spark quenching device in the form of sprayers, of which several are on the market. These will extinguish the sparks, condense and retain the fine top flame dust, and absorb the sulphurous portions of the waste gases.

The MacLean Pub. Co., Ltd.

(ESTABLISHED 1888.)

JOHN BAYNE MACLEAN - - - - - President
H. T. HUNTER - - - - - General Manager

PUBLISHERS OF

CANADIAN MACHINERY AND MANUFACTURING NEWS

A weekly newspaper devoted to machinery and manufacturing interests, mechanical and electrical trades, the foundry, technical progress, construction and improvement.

H. V. TYRRELL - - - - - Business Manager

EDITORIAL STAFF:

PETER BAIN, M.E., J. H. WILLIAMS, C. W. BYERS

OFFICES:

CANADA	GREAT BRITAIN
Montreal, Rooms 701-702 Eastern Townships Bank Bldg.	London, 88 Fleet Street, E.C. Phone Central 12960 E. J. Dodd
Toronto, 143-149 University Ave., Phone Main 7324	UNITED STATES
Winnipeg, 34 Royal Bank Bldg., Phone Garry 2313	New York, R. B. Huestis, 115 Broadway, New York, N. Y., Phone 2209 Rector
Vancouver, H. Hodgson, 2640 Third Ave. West.	Chicago, A. H. Byrne Room 607, Marquette Bldg. 140 S. Dearborn St., Chicago

CABLE ADDRESS:

Macpubco, Toronto. Atabek, London, Eng.

SUBSCRIPTION RATE:

Canada, \$2.00; United States, \$2.50; Great Britain, Australia and other colonies, 8s. 6d. per year; other countries, \$3.00. Advertising rates on request.

Subscribers who are not receiving their paper regularly will confer a favor on us by letting us know. We should be notified at once of any change in address, giving both old and new.

Vol. IX. APRIL 3, 1913 No. 11

PRINCIPAL CONTENTS.

Axioms Concerning Manufacturing and Production Costs.....	341-344
Typical Methods of Attaching Chucks to Lathe Spindles.....	345-346
General	346-348
Drydock at Prince Rupert, B.C.....Prevention of Blast Furnace Accidents.....Machine Tool Exhibits at Foundrymen's Convention.....Quebec Minerals.....Conditions near Cochrane.....Hydraulic Transmission Truck Hauls 45-Ton Load.	
The Useful Life of Machinery and Its Economic Limits	349-350
General	350-352
Boring on a large Casting.....Electricity at Cape Breton Coal Mines.....Freezing Process in Foundation Work.....Sun Power.....The Construction of Engineering Workshops.....Oxide of Aluminum Insulation.....Recent Judicial Decisions.....The Simmons Mfg. Co.'s Safety Plan.....Trenton Creosoting Plant.....An Engine Breakdown.	
Machine Shop Methods and Devices	353-354
Rabbiting Fixtures.....Chamfering a Lot of Special Screws.....Tool for Removing Broken Set Pins.....A Drilling Jig.....The Eastern Car Co. Plant.	
Developments in Machinery	355-356
Trolley for Electric Travelling Cranes.....New Model Plain Milling Machine.	
General	356-357
Boring and Lacing Spring Shackles.....Engineering Convention.....Worm Gearing Data.	
Foundry Practice and Equipment	358-359
Cupola Features.	
Editorial	360
Industrial and Construction News	361-365
Engineering	General Industrial
Municipal	Railways
Building Notes	Bridges
Contracts Awarded.....	Waterworks
Obituary	Trade Woodworking
Miscellaneous	Tenders
Catalogues.....	Personal
	Obituary
	Miscellaneous
	New Incorporations.....
Selected Market Quotations	366-367
General Market Conditions and Tendencies	367-368

WRITING ARTICLES

THERE was never a time in the world's history when so many boys were being fitted for the engineering profession as now. Every day witnesses a new opening in this calling, and it has become necessary for a boy to choose one of a hundred branches of the craft. It has been emphasized over and over again, that this is the age of specializing. No longer are there masters of the engineering profession, it being now an impossibility. On this continent especially, the tendency is to make a man expert in one branch. If he be a mechanic he may be an expert on the milling machine or on the lathe, and with a particular kind of work. He may be expert on refrigerating machinery or he may be an authority in electrical machinery design. Scientific management tends towards this, and for that reason it is deprecated as an evil in some quarters. While congestion exists in many branches of the engineering profession, there are still several directions in which there is a dearth of men, and it is hard for those who have been drilled in a special line to leave it, in order that they may start at the bottom in some other branch.

It is our intention to speak here of a branch which is open to every engineer and every mechanic; one that is calling out for help, although the response is very meagre. Men are working hard, day and night, with the hope of advancing even a little in their respective lines, and yet right at their finger ends is a chance to do something easily, in their homes at night, in the street car, wherever they be. Thousands of students in engineering colleges are studying with the hope that one day they will be admitted into some plant where they will be enabled to start to climb the crowded ladder to success. Did these men ever sit down and make a serious attempt to describe on paper what they have learned? Judging by the few engineers who can write a readable description of a piece of machinery, little has been attempted along this line, yet it is here that a field awaits the engineer or mechanic who knows something, and can tell it in a manner that is intelligible to his fellow workers. For some the field may be very limited. The man in the foundry may be able only to write on his way of making small brass castings, and of the few little devices known only to him, whereby his work is facilitated; but once he has committed these to paper, the field will grow, and his eyes will be opened.

We would recommend that men who wish to improve themselves, should take the time and trouble to write out a lucid account of methods and devices with which they are familiar, and that they submit these to some technical paper. At first their work may be crude, but editors are able to brush it up and make it respectable. On a second attempt, the writer will meet with greater success, and gradually he will discover a means of improving himself both in mind and pocket.

The engineer will benefit likewise. In his daily work, he comes in contact with machinery, systems, and achievements that are of interest to the whole engineering world. It may surprise him to know that he would have great difficulty in describing what he has seen or accomplished. One day he is called on to read a paper before some engineering society, and it gives him a nightmare. How different and easy it would be, if he had been accustomed to such work.

It would be much better if, in our engineering colleges, students instead of writing dry matter-of-fact statements of experiments performed, were trained to make pleasant readable reports. Engineers and machinists read and are entertained every day by graphic descriptions of work which they themselves perform. If they only knew it, they themselves might write these articles, and write them much better.

INDUSTRIAL ^A_N^D CONSTRUCTION NEWS

Establishment or Enlargement of Factories, Mills, Power Plants, Etc.; Construction of Railways, Bridges, Etc.; Municipal Undertakings; Mining News.

Engineering

Wallaceburg, Ont.—The Wallaceburg Brass and Ironworks will enlarge its plant.

Toronto, Ont.—The Northern Foundry and Machine Co., Ltd., have increased their capital from \$50,000 to \$100,000.

Weyburn, Sask.—The J. I. Case Co., of Racine, Wis., will establish a distributing branch here. C. E. Kiser will be in charge.

Pembroke, Ont.—The Steel Office Equipment Co. will build a large plant here, the city having granted the concessions demanded.

Quebec, Que.—The Canadian General & Shoe Machinery Co. is in liquidation and A. Lefebvre has been appointed provisional guardian.

St. John's, Nfld.—It is understood that eleven locomotives were destroyed in the Reid-Newfoundland Co. fire recently. The total loss is exceedingly heavy.

Galt, Ont.—The Galt Brass Co., is having plans prepared by its own draftsmen for an addition to its factory, 50 x 80 ft. L. C. Howell is manager.

Quebec, Que.—Several big improvements are planned by the Eastern Canada Steel Co. at its plant at St. Malo, Quebec, which will double the output, and give employment to 250 men.

Sarnia Ont.—The John Goodeson Thresher Co., Ltd., advise that the recent fire on their premises did damage amounting to \$1,000, and was confined to the cupola house, which was shut down for one day only.

Windsor, Ont.—The plant to be erected by the Swedish Crucible Steel Co. will cost \$19,000, and will measure 125 x 60 ft. Nels. L. Olson, of Detroit, is president. The Vincent Steel Process Co. will spend \$10,000 on their plant.

Welland, Ont.—A Chicago Company have bought out Chemicals, Ltd., and will erect a plant for the reduction of iron ore by an electrical process, and for the manufacture of a standard product. The plant will be in operation by October. Fred Blackington, Chicago, conducted negotiations with Chemicals, Ltd.

Medicine Hat, Alta.—The Saskatchewan Bridge and Iron Co., of Moose Jaw, Sask., have secured a site of 15 acres at Medicine Hat, and will erect a branch plant costing \$100,000, to employ 150 men. The plant in Moose Jaw will be doubled. Work on the new building which includes a foundry will start immediately.

Preston, Ont.—The Dominion Bronze Mfg. Co., Ltd., will build a plant here for the manufacture of brass fittings at a cost of \$25,000. They will employ 50 men. D. M. Campbell and W. J. Hodgins, are general manager and secretary-treasurer respectively. The buildings will all be one-storey, as follows: Moulding shop 80 x 40; machine room, 40 x 100; polishing room, 40 x 40; shipping room, 40 x 20; plating room, 20 x 30; laquering room, 30 x 20.

Electrical

Calgary, Alta.—The city may spend \$500,000 on its own power plant.

Montreal, Que.—The Montreal Tram-

ways Company will spend more than \$2,000,000 in improvements.

Cannington, Ont.—On April 15th the ratepayers will vote on a by-law to raise \$12,000 to provide a plant for distributing Hydro-Electric power.

Toronto, Ont.—The Northern Electric and Manufacturing Co. has plans for a new factory of structural steel construction, estimated to cost \$100,000. New equipment will be required.

Sydney, N.S.—Extensions planned by the Cape Breton Electric Co. include additional cars, increased car house at Sydney, double-tracking and sidings, a steam unit at North Sydney as an auxiliary, turbine unit, boiler and other equipment for Sydney power station. Expenditure will exceed \$350,000.

Hamilton, Ont.—The Cataract Power Company has announced a reduction of 25 per cent. in its commercial lighting rates. In announcing the cut, the company has made the following statement: "The fact that we have now reduced our former rates by 25 per cent. means that we will supply commercial lighting power at less than cost. We will lose money, but we prefer to stick to our old customers."

Berlin, Ont.—Hon. Adam Beck, chairman of the Hydro-Electric Commission, has notified the Berlin Light Commission that the cost of street lighting for this year in the city would be \$16,000. When estimates were being struck by the City Council, it was found that the 1,650 lights installed last year would cost over \$17,200, and this amount was reduced \$1,000 by cutting out lights in outlying districts. The Hydro lighting

C. P. R. MACHINE TOOL REQUIREMENTS

The following is a list of machine tool equipment to be purchased by the C.P.R. for their new machine shop being built at McAdam Junction, N.B.:

- 1—48-inch belt-driven press, 200 tons pressure.
- 1—Double axle lathe, with crane mounted on the machine.
- 1—42-inch car wheel boring machine.

- 1—80-inch driving wheel lathe.
- 1—24-inch drill press.
- 1—1/2-inch to 4-inch pipe threading machine.
- 1—24-inch x 12 ft. double back-gear engine lathe.
- 2—20-inch x 8 ft. double back-gear engine lathe.
- 1—36-inch x 14 ft. double back-gear engine lathe.
- 1—Universal grinding machine.

- 2—18-inch x 8 ft. double back-gear engine lathe.
- 1—Pneumatic tube welding hammer.
- 1—Centering machine.
- 1—Nut facing machine.
- 1—51-inch vertical boring mill.
- 1—1,600-lb. steam hammer.
- 1—40-ton hydraulic press, for pressing brasses in axle.

system will include all lights at present in use and additional lights to be put up this year. In order to provide for the increased demand for power, the Hydro Commission will increase the capacity of the local transformer station from 3,000 horse-power to 5,000 horse-power, which will enable the local commission to increase the load by 1,300 horse-power this year.

General Industrial

Winnipeg, Man.—Fire did \$15,000 damage to the warehouse of the Canadian Oil Company, March 22.

Portage la Prairie, Man.—Harry Stephens contemplates establishing brick-making plants at Edmonton and Calgary, Alberta.

Leamington, Ont.—A cannery to cost \$25,000, is planned for the Gorman Eckert Co., Rectory St., London. Manager William Gorman.

Dorchester, Ont.—A. Carrothers has purchased the old Anglican church, Dorchester, and will remodel it and purchase machinery and equipment for a flour mill.

Montreal, Que.—The Atlas Glass Works, Ltd., are building a new plant at Ville St. Pierre, Que., which will be ready for operation in May, and will employ 700 hands.

Glencoe, Ont.—The Glencoe Canning Co. will be started here by Toronto capitalists, who will occupy the Hamilton & Lewitt Knitting Co. A plant will be erected worth \$50,000, employing 75 hands, in time for the tomato crop. Mr. Chapman is the manager.

Moose Jaw, Sask.—The National Sales Corporation of Cincinnati have been granted land as a bonus to locate a large flax mill within five miles of Moose Jaw. A. L. Irish is president of the National Sales Corporation. \$350,000 will be spent on plant and machinery.

Winnipeg, Man.—The canneries plant of the Western Canada Cold Storage and Packing Co. was wrecked by fire recently while new machinery was being installed. The building was worth \$80,000 and the machinery \$30,000. The plant will be rebuilt. Captain Bruce is the secretary.

Courtright, Ont.—A new salt refinery has been erected here by the Western Salt Co., which has another refinery at Mooretown. The machinery cost \$125,000. It does away with the old system of pans and refining by a vacuum process. The company is composed of D. A. Gordon, M.P., president; R. B.

Hanna (Toronto), vice-president; John R. Robertson (of McKenzie & Mann, Toronto), secretary; and N. A. Leach, manager.

Vancouver, B.C.—The Canadian Fish and Cold Storage Co., with headquarters at Prince Rupert, plan extensive operations during this year. This concern is controlled by Sir William McKenzie and a group of Old Country associates. Owning a fleet of gasoline boats as well as several trawlers, built at Grimsby, England, the company expects to reach an annual output of \$5,000,000. A fertilizing plant is being erected on one of the islands adjacent to Prince Rupert. The cold storage plant, built at a cost of \$1,000,000, has a capacity of 6,000 tons. Pending the completion of the Grand Trunk Pacific Railway, the output will be shipped east via boat to Vancouver. The company purposes shipping fresh spring salmon to England, France and Germany.

Municipal

Bridgeburg, Ont.—The city council will install a fire alarm system.

Amqui, Que.—The City Council is planning the construction of a municipal electric-light plant.

Glace Bay, N.S.—The installation of additional equipment in the municipal electric light plant is under construction.

London, Ont.—The city has paid the McCormick Mfg. Co. \$125,000 for property, on which a Federal Square will be built.

Edmonton, Alta.—Plans are being prepared by A. Jeffers, city architect, for the construction of an addition to the municipal power plant to provide additional power required for the operation of the proposed municipal railway extension. Estimated cost, \$485,000.

Railways—Bridges

Winnipeg, Man.—The new steel bridge over the Red River to be built by the city will not be placed on Water Street.

Prince Albert, Sask.—The Saskatchewan Government is being urged to construct a second bridge over the river here.

Hull, Que.—The Hull Electric Railway Co. will run an extension to Connaught Park race course, ½ mile long double track.

Halifax, N.S.—An election will probably be held at Halifax, N.S., to vote on the purchase by the city of the Halifax Electric Tramway Co.

St. John, N.B.—The C.N.R. plans to spend \$1,500,000 on the Atlantic Division during the coming year. \$630,000 is allotted for the new million-bushel elevator at St. John.

Little Current, Ont.—The cement work on the central pier of the Algoma Eastern Railway bridge is finished, and steel work will be started April 20.

St. John, N.B.—Plans are in progress for a steel railway bridge to be built by the Canadian Pacific over Reversing Falls. W. Rownie, superintendent.

St. Catharines, Ont.—The ratepayers voted against building a viaduct across the old Welland Canal to the G.T.R. station. A less expensive bridge is favored.

Hamilton, Ont.—An incline railway at a cost of \$200,000 is contemplated by the Hamilton Incline Co. The railway will be about 1,000 feet in length and will require boiler houses, etc. C. Diescher & Sons, of Pittsburgh, Pa., are engineers.

Port Colborne, Ont.—The Niagara, St. Catharines & Toronto Railway Company will start work shortly on the further extensions of their line from Port Colborne to Fort Erie. The line will be extended through Bridgeburg to the city of Niagara Falls.

Bristol, N.B.—Dr. Somerville of Bristol and D. H. Lamont and others of the Classville Car Co., N.B., are applying to the New Brunswick legislature for a charter to build a steam railway from Bristol to a point on the Transcontinental railway at Juniper Brook.

Victoria, B.C.—The Legislature of British Columbia has provided the sum of \$150,000 for the purchase of improved road machinery. A total of almost \$6,000,000 will be spent in the province this year for roads, bridges and wharves, of which the largest item is for roads.

Ottawa, Ont.—The Ottawa, Rideau Lakes & Kingston Ry. Co. has completed surveys for its proposed line from Ottawa to Kingston. At a recent meeting at Ottawa, the following Board of Directors was elected: N. M. Clougher, of London, President; William Dennis, R. H. McElroy, M.P.P.; Dr. H. D. Ball, G. L. Dickinson

Edmonton, Alta.—Work has commenced on the last span of the high level bridge which has been under construction since May, 1910. It is expected that the bridge will be in operation by about the middle of June. The length between abutments is 2,560 feet. The extreme height above the mean level is 153 feet, while the piers are 103 feet

high. The bridge consists of an upper and lower deck. A railway track will run along the upper deck, also a double street car track, the lower will be used for vehicular and pedestrian traffic, the sidewalks having a clearance of eight feet and the roadway, twenty-three feet.

Water-Works

Edmonton, Alta.—Water meters will be purchased by the city commissioners. Clerk, Chas. E. Cox.

Crowley, Alta.—The city contemplates the expenditure of \$10,000 for the installation of a waterworks system.

Wallaceburg, Ont.—The ratepayers will vote on a by-law, to spend \$130,000 for waterworks, on June 2.

Redcliff, Alta.—The ratepayers have decided to purchase the waterworks, and will spend \$20,000 in making improvements to the system.

Arnprior, Ont.—Trouble has been experienced by the town with a pump at the waterworks. Engineer McRae, of Ottawa, is being consulted.

Winnipeg, Man.—The contract for the construction of an 18,000,000 gallon reservoir will be awarded shortly. It will cost \$80,000 and the board of control recommend that the work be given to the engineer of construction.

St. Thomas, Ont.—Waterworks to cost \$105,000, are contemplated by the city council. Plans have been prepared to lay a 20 in. main, erect a standpipe and put in new boilers at the pumping station. Engineer in charge, James A. Bell.

Sarnia, Ont.—Tenders for the waterworks are too high. The figures for the whole work exceeded by a considerable amount the estimate of \$240,000. New tenders may be called for. Contractors complain that specifications are not definite enough.

Building Notes

Montreal, Que.—Mr. W. H. Dandur and will erect a ten-storey building in this city. The cost is estimated to be \$1,000,000.

Vancouver, B.C.—The Canadian Fairbanks-Morse Co. are building a warehouse in twin cities are concerned. The Turf five storeys high.

Edmonton, Alta.—Work will be started in the spring on a warehouse and offices for the International Harvester Co. at North Battleford, Sask. It will be of five stories, to accommodate 135 carloads of machinery.

Stratford, Ont.—J. S. Russell has prepared plans for the new Farquharson-Gifford Furniture Factory, and tenders will be called for in a week. It will measure 60 x 100 ft., and be four storeys high. The boiler-room will measure 30 x 30 ft. The office, machine and shipping rooms will be on the ground floor.

Wood-Working

Sarnia, Ont.—The R. Laidlaw Lumber Co. are building an addition to their plant, and installing new machinery.

Guelph, Ont.—The R. Laidlaw Lumber Co. of Toronto, will build a planing mill and sash and door factory here.

Tenders

Calgary, Alta.—Brown and Vallance of Winnipeg, are receiving tenders for a large warehouse for the Sherwin-Williams paint Co., to be erected in Calgary. The building will be three storeys 50 x 114 ft.

Winnipeg, Man.—Tenders addressed to the Chairman, Board of Control, will be received up to May 15th, for the manufacture, delivery and erection in the Generating Station at Point duBois of two 3-phase generators, for direct connection to double reaction turbines, and for spare parts for same. M. Peterson, Secretary.

Winnipeg, Man.—Tenders addressed to the Chairman, Board of Control, will be received up to April 14th, for supply of the following equipment for the King George Hospital: 1—Steel furniture, sterilizers and sundry equipment. 2—Steam tables, kitchen utensils and bath room accessories. 3—Lockers. 4—Mattresses and pillows. M. Peterson, secretary.

Montreal, Que.—Sealed proposals will be received at the office of the Board of commissioners, city hall, Montreal, up till April 15, for the furnishing and erecting, at the Low Level Pumping Station of the Montreal Water Works, two water tube boilers, with all their fittings and appurtenances complete: the whole in accordance with the general specifications and plans to be seen and examined at the office of the Engineer, Superintendent of Water Works, City Hall, Montreal. L. N. Senecal, Secretary.

Contracts Awarded

Calgary, Alta.—The City Council have awarded the contract for the supply of fire apparatus to the Webb Company. Their tender price was \$31,175.

St. Thomas, Ont.—The Hope Engineering and Supply Co., of Pittsburg, Pa., has been awarded the contract for the extension of the 12-inch pipe line of the Dominion Natural Gas Co.

Ottawa, Ont.—The Government has awarded to the Cammell-Laird Company a contract for the construction of a

powerful ice-breaking steel railway ferry, to operate between Quebec and Levis.

Lethbridge, Alta.—The contract for a motor car for the fire department has been awarded to the H. T. Henderson garage. It will be a Knight-Russell machine, costing \$3,223. The city will build a new fire hall.

Montreal, Que.—The city has awarded a contract to Messrs. Laurin & Leech for the laying of a new 36 inch steel water-pipe from Point St. Charles to the McTavish St. reservoir. About \$100,000 will be expended on this work.

Winnipeg, Man.—The contract for the first group of the St. Chad's College buildings, to be erected for the Anglican diocese of Qu'Appelle in Regina, has been let to R. J. Lecky, of Regina, for \$90,000. The plans were drawn by Brown and Vallance, of this city.

Fort William, Ont.—The Burrell Construction Co., of Chicago, have been awarded the contract for the construction of the Western Elevator Co.'s grain house near this city. The building is to be of reinforced concrete, with a capacity of 1,100,000 bushels of grain, and will cost about \$100,000.

Oil Springs, Ont.—Thos. Johnstone, manager of the Petrolea Bridge Co., says he has just closed a contract for a \$10,000 job for the town of Wallaceburg. Mr. Johnstone stated that they would commence construction as soon as the weather conditions are favorable. The contract calls for two large cement approaches and piers.

Edmonton, Alta.—The Waller-Robertson Co. have been awarded the contract for supplying the city with a 4,000 k.w. turbo generator. The turbine is to be capable of driving an electric generator giving an output of 4,000 k.w. as the normal full load, and an overload of 25 per cent. for two and 50 per cent. for one hour respectively.

Prince Rupert, B.C.—The following contracts have been awarded in connection with the \$3,000,000 G. T. P. dry dock which is in course of construction at Hays Cove. The contract for the steel has been let to the United States Steel Products Co. The Wineland Building and Engineering Co., of Vancouver, has secured the contract for the

construction of the reinforced concrete power house as well as the superstructure of all the buildings.

Trade Gossip

Mr. Robert Morrill, shipbuilder, of Collingwood, has charge of the work of repairing and overhauling the steamer Manitou, which was recently raised.

The **Siemens Company of Canada**, have received the order for a 1,500 K.W. turbo-generator for the city of Moose Jaw, Sask. The machine will run at 3,600 r.p.m. and be suitable for a 3-phase 60-cycle circuit. The generator will be direct coupled to a Willans & Robinsion steam turbine.

The **Laurentide Pulp & Paper Co.**, are completing additions to their plant at Grand Mere which will increase output of supplies from 80 tons a day to 115 tons. The installation of a new digester is now nearly completed, and this will result in the increase mentioned. The company has further decided upon two other changes. One of these is the establishment of a N.Y. office, and the other of a traffic department in Montreal. The New York office will be located in the new Aeolian Building, and Mr. J. F. Paten will be manager. The establishment of a traffic department in Montreal will mean the enlargement of their present offices. Mr. J. H. A. Acer, the Montreal manager, has already arranged for additional space. Matters of rates and routing will be dealt with by the traffic department, for which a head is yet to be appointed.

Personal

J. G. Glassco has been appointed manager of Winnipeg light and power department at a salary of \$4,800.

Lewis Lukes, formerly vice-president and general manager of the Monterey Railway, L. & P. Co., one of the Mackenzie and Mann group, has been appointed assistant to the President of the Canadian Northern Railway, with headquarters at Toronto.

Mellis Ferguson, city engineer of Guelph, Ont., has placed his resignation in the hands of the Public Works and Sewerage Commission. It is understood that he will likely receive the appointment of city engineer at St. Thomas. Assistant City Engineer Holland will take his place temporarily.

Arthur Skidmore, who for the past ten years has been associated with the motive power department of the G. T. R. at Stratford, has been promoted to the position of chief engineer of the

steam electric power plant in connection with the company's shops there. **H. Westwood**, formerly of the Waterloo Mfg. Co., has been appointed assistant engineer.

Mr. Geo W. Thompson has been appointed by the city council of Westmount, Que., to the position of temporary acting city controller at a salary of \$5,000 a year. The appointment holds good until next November when the council will decide upon a permanent official. Many applications for the position had been received from England and the United States as well as throughout the Dominion.

Mr. Thompson was previously superintendent of the light and power department of the city.

J. J. Conlin, formerly with the R. & O. Nav. Co., Ross & Greig, and The Garth Co., is now president and manager of the General Manufacturers Agencies, Ltd., 515 New Birks Building, Montreal. His firm are Canadian agents for Kieley & Mueller high grade steam specialties; the thermograde system of heat regulation; the Van Auken system of vacuum heating; the national system of automatic temperature control; Benj. F. Kelley & Son, heaters; and the Massachusetts Fan Co. They also handle The Shone system of sewerage ejectors, steam power pumps, filtering systems, sanitary individual washbowls, metal lockers, racks and steel tanks for all purposes.

Frank C. Askwith, who has been recommended by the Ottawa Board of Control for the position of assistant city engineer, has been connected with the city engineer's department for the last five years. He is the son of John E. Askwith, Ottawa deputy police magistrate, and was born in Chatham twenty-nine years ago. He worked two years for Fetherstonhaugh & Co., patent engineers, and in 1903 and 1904 was connected with the Grand Trunk Pacific Railway engineering staff, doing preliminary, location and office work in Saskatchewan and Manitoba. In 1905 he was with the Library Bureau of Canada, and for the following two years was connected with the irrigation department of the C. P. R. at Calgary. He joined the city engineer's department in 1908, and for the last three years has been roadway engineer. He has been acting engineer since December 20, and has given every satisfaction.

Obituary

Duncan S. Lothian, who has superintended the building of many of the largest mining plants on the Continent, died recently in the West. He was born

59 years ago at Breadalbane, Ont. Mr. Lothian became the representative of the firm of Fraser & Chalmers, of Chicago, then the largest manufacturers of mining machinery in America. After traveling for them on the Pacific coast between Mexico and Alaska for many years, he decided to enter the lumber business, and built a mill at Sault Ste. Marie, Algoma, being the first mill owner in the district. After three years' operation, a fire destroyed the entire plant. Going West again to restore his fortune, he started the lumber firm of D. S. Lothian & Co., at Buckley, Washington, but within a year fire again reduced his mill to ashes. Returning to mining work under his old employers, Mr. Lothian installed a great deal of the machinery at Rossland, also the concentrating plant at the old Moneyspinner mine on Fire Mountain. At Alaska he built the quartz mill at Bernard Bay, and an addition to the plant of the Treadwell mines. In Montana he built the Blue Bird mill at Butte, the bi-metallic mill at Granite Mountain and an addition to the plant of the Anaconda Co. In New Mexico he built the quartz mill at the White Oaks mine.

Miscellaneous

Navigation Opens.—Navigation on the Great Lakes is open as far as the twin cities are concerned. The turbinia started on her initial trip from Toronto to Hamilton on Tuesday April 1.

Athabasca Landing.—A report emanating from Edmonton states that gas has been struck near Athabasca Landing. The pressure is said to be 400 pounds and the flow between 1½ and 2 million feet per day.

Drainage Machinery.—Mr. Archie B. McCoig, M.P. for West Kent, has elicited a promise from the Minister of Finance to consider a suggestion to put drainage machinery on the free list. At present there is a duty on it of 27½ per cent.

Halifax, N.S.—Application for incorporation will be made by the Canadian Gear Works, Ltd. The capital will be \$48,000, with works in Newcastle, N.B. J. E. Ander, H. K. Pell, E. A. McCurdy, and W. H. Belyea, all of Newcastle, are among the incorporators.

The **Elbow River Suburban Railway Co.**, is making application to the Alberta Government for a charter. The men behind the scheme are all of Calgary and include the following:—Wm. Georgeson, president, Dr. Ings, O. S. Chapin, Geo. L. Peet, E. H. Crandall and A. D. Connors.

Making Steel Without a Blast.—A London cable says that a new process has been discovered for converting iron ore into any grade of steel without the aid of a blast furnace. The steel being made in a single operation, it is claimed that the cost of manufacture will be cut to one-third of the present figures.

New Incorporations

C. Emile Morissette Limitee, incorporated at Ottawa as general contractors and manufacturers agents. Capital \$100,000. Incorporators:—C. E. Morissette, C. T. Morissette, Arthur Boucher, Arthur Mercier, and D. A. Gagnon, all of Quebec, P.Q.

Swedish Canadian Steel Co., Ltd., incorporated at Ottawa. Capital \$50,000. Incorporators:—J. J. Creelman, G. S. Stairs, J. B. Henderson, Florence E. Seymour, and Beatrice I. Brandt, all of Montreal, P.Q.

The Fort Garry Construction Co., Ltd., have been incorporated in Winnipeg with a capital of \$50,000 as building contractors. D. O. Wood and A. J. Wills, of Winnipeg, are among the incorporators.

The Miller Construction Co., Ltd., incorporated at Toronto, as general contractors, capital \$40,000; incorporators, R. W. Miller, Alfred Weeks, George Weeks, Stanley S. Fryer and Bernard Fryer, all of Hamilton, Ont.

The John Inglis Co., Ltd., incorporated at Ottawa as manufacturers of engines, boilers, etc., in Toronto. Capital \$1,000,000. Incorporators:—E. A. J. Case, J. B. Taylor, C. G. Lynne, H. E. Wallace and L. W. Wood, all of Toronto, Ont.

North American Steel Corporation, Ltd., incorporated at Ottawa, to manufacture iron and steel at Montreal. Capital \$100,000. Incorporators:—A. H. Elder, P. F. Brown, S. T. Mains, W. R. Ford and A. F. Teulon, all of Montreal, and D. A. Gagnon, all of Quebec. P.Q.

The Independent Natural Gas Co., Ltd. incorporated at Toronto, to bore for petroleum and gas: capital \$300,000; incorporators, F. Lalor, John A. Burns, W. J. Aikens, and G. R. Smith, all of Dunville, Ont., and W. T. Henderson, of Brantford, Ont.

The Beaver Brass Mfg. Co., Ltd., incorporated at Toronto, to acquire and carry on the business of The Beaver Brass & Lock Works, capital \$40,000. Incorporators, F. L. Burton, Edmund H. Edwards, Hugh P. Edwards, Earnest C.

Jewell, and W. David Sanderson, all of Toronto, Ont.

Canadian Drednot Motor Trucks, Ltd., incorporated at Ottawa, as manufacturers and dealers in automobiles, cycles, motor trucks, engines, etc. Capital \$250,000. Incorporators:—H. Salter Ross, J. H. Rigny, Oswald F. Sheaer, V. S. Ross, and Florence Salmon, all of Montreal, P.Q.

The Northern Tire & Rubber Co., Ltd. incorporated at Toronto, to manufacture all kinds of rubber articles; capital \$160,000. Incorporators, T. A. Fleming, C. S. Fenton & A. G. Roberts, all of Cleveland, Ohio, and W. L. Nelson and J. H. Cole, both of Owen Sound, Ont., and J. W. Albaugh of Canton, Ohio, and C. Price, of New Berlin, Ohio.

Marine

Vancouver, B.C.—Huge docks will be constructed along the waterfront of the E. H. Heaps properties, capable of accommodating deep sea vessels.

Catalogues

The Garvin Machine Co., New York City, have issued Circular No. 193, entitled a "Daily Reminder of the Garvin Product" in which will be found illustrations and briefly featured references to the variety of product manufactured by them. Attention is drawn to the fact that each individual machine has its particular descriptive circular number appended, making it highly convenient for intending purchasers to secure full and complete data concerning a tool in which they may be interested.

ABITIBI PULP & PAPER CO.

CONTRACTS for the plants and buildings of the Abitibi Pulp & Paper Co. have all been let and the work is being pushed ahead as fast as weather conditions will permit. The contract for buildings and hydraulic work has been awarded to Morrow & Beatty, and the other work divided among several other contractors. The work on the buildings, power dam, and so forth will be finished by the first of December according to contract; and the installation of machinery will be completed within two months after that date.

The company proposes to complete at once a 180-ton pulp mill and operate this to turn out in excess of 50,000 tons a year, and to develop, at Iroquois Falls, 21,500 horse-power. The latter, which

is only part of a total of 57,000 horse-power the company owns, will be ready before the mills. The pulp mills will use about 16,000 horse power, leaving a substantial balance for sale.

The Board of Directors is made up of the following gentlemen:—Messrs. F. H. Anson, President; J. A. McAndrew, Sir Thos. Tait, Hon. George Gordon, James Playfair, Georges Challes, and D. Lorne McGibbon.

GRINDING WHEELS.

THERE are two reasons why a wheel appears softer in the centre. The surface speed decreases in proportion to the diameter when the wheel wears smaller. If the surface speed decreases, the wheel will act softer, and a larger quantity of abrasive be required to grind a certain quantity of materials. By decreasing the diameter, the thickness of layer worn off increases; in other words, wearing off the same quantity of abrasive will decrease the diameter faster when the diameter of the wheel is small than when it is large.

WELLAND'S NEW INDUSTRY.

IN the new plant of the Metal Chemicals Co., Welland has an industry that is unique and distinct from its many other manufacturing concerns.

The company handles Cobalt silver and refines it by a new process which is a secret of the owners of the plant. The entire output of refined silver, Cobalt metal dye and arsenic is contracted for, and the company will be busy from the moment that the plant is in complete operation. At present it is only partially so.

When the company purchased the plant of the defunct Electro-Steel Co., they at once set to work to remodel, enlarge and otherwise improve the buildings. This work has been completed and the plant is one of the most complete in Welland. In one department are the boilers and grinders, and in another the huge vats. There is also a large chemical laboratory, a finishing room and several other departments. The arsenic is separated in a specially constructed building. The blue metal dye manufactured is one of the chief products of the plant, although quantities of Cobalt silver are also refined.

It is expected that within a few weeks the entire plant will be in operation.

The capital stock of the Trussed Concrete Steel Company of Canada, Ltd., has been increased from \$200,000 to \$500,000.

SELECTED MARKET QUOTATIONS

Being a record of prices current on raw and finished material entering into the manufacture of mechanical and general engineering products.

FIG IRON.

	Per Ton.	
Foundry No. 1 and 2, f.o.b., Midland	\$19 25	\$20 50
Gray Forge, Pittsburg		16 90
Lake Superior charcoal, Chicago		18 00
	Mont'l.	Tor'to.
Canadian f'dry, No. 1..	\$20 50	\$20 50
Canadian f'dry, No. 2..	20 00	20 00
Middlesboro, No. 3....	23 50	23 50
Summerlee, No. 2	25 00	26 50
Carron, special	25 00
Carron, soft	25 00
Cleveland, No. 1	24 25	25 00
Clarence, No. 3	23 75	24 50
Jarrow		25 50
Glengarnock		26 00
Radnor, charcoal iron.	30 00	34 50
Ferro Nickel pig iron (Soo)		25 00

BILLETS.

	Per Gross Ton.	
Bessemer billets, Pittsburgh ...	\$28 50	
Open hearth billets, Pittsburgh.	29 00	
Forging billets, Pittsburgh.....	36 00	
Wire rods, Pittsburgh	30 00	

FINISHED IRON AND STEEL.

Per pound to large buyers:

	Cents.	
Common bar iron, f.o.b., Toronto..	2.10	
Steel bars, f.o.b., Toronto.....	2.20	
Common bar iron, f.o.b., Montreal.	2.15	
Steel bars, f.o.b., Montreal.....	2.25	
Bessemer rails, heavy, at mill....	1.25	
Iron bars, Pittsburgh	1.70	
Steel bars, Pittsburgh, future	1.40	
Tank plates, Pittsburgh, future...	1.45	
Beams, Pittsburgh, future	1.45	
Angles, Pittsburgh, future	1.45	
Steel hoops, Pittsburgh	1.60	
Toronto Warehouse f.o.b., Toronto.		
	Cents.	
Steel bars	2.30	
Small shapes	2.40	
Warehouse import, freight and duty to pay:	Cents	
Steel bars	1.95	
Structural shapes	2.05	
Plates	2.05	
Freight, Pittsburgh to Toronto:		
18 cents carload; 21 cents less carload.		

BOILER PLATES.

	Mont'l. Tor'to.	
Plates, 1/4 to 1/2-in., 100 lbs.	\$2.40	\$2.40
Heads, per 100 lbs.....	2.65	2.95
Tank plates, 3-16 in.	2.60	2.60
Tubes, per 100 ft., 1 inch	9.00	8.50
“ “ 1 1/4 in.	9.00	8.50
“ “ 1 1/2 “	9.00	9.00
“ “ 1 3/4 “	9.00	9.00
“ “ 2 “	9.00	9.00
“ “ 2 1/2 “	11.50	11.50
“ “ 3 “	12.00	12.00
“ “ 3 1/4 “	13.75	13.75
“ “ 3 1/2 “	15.00	15.00
“ “ 4 “	18.50	18.50

BOLTS, NUTS AND SCREWS.

	Per cent.	
Stove bolts	80 & 7 1/2	
Machine bolts, 3/8 and less	65 & 5	
Machine bolts, 7-16.....	57 1/2	
Blank bolts	57 1/2	
Bolt ends	57 1/2	
Machine screws, iron, brass	35 p c.	
Nuts, square, all sizes.....	4c per lb off	
Nuts, Hexagon, all sizes..	4 1/4 per lb off	
Flat and round head.....	35 per cent.	
Fillister head	25 per cent.	
Iron rivets	60, 10, -0 off	
Wood screws, flathead, bright	85, 10 p c off	
Wood screws, flathead, brass	75, 10 p c off	
Wood screws, flathead bronze	70, 10 p c off	

WROUGHT IRON PIPE.

The following are Toronto jobbers' discounts on pipe. (Card weight) in effect from October 11th, 1912:

	Standard	Buttweld Black Gal.	Lapweld Black Gal.
1/4 3/8 in.	63	48
1/2 in.	68	58
3/4 to 1 1/2	72 1/2	62 1/2
2 in.	72 1/2	62 1/2	69 1/2
2 1/2 to 4 in. ..	72 1/2	62 1/2	71 1/2
4 1/2 to 6 in.	72	62
7, 8, 10 in.	66 1/2	54 1/2

X Strong P. E.

1/4, 3/8, 1/2 in. ..	64	54
3/4 to 2 in.	68	58
2 1/2 to 3 in. ...	68	58
3 1/2 to 4 in.	65	55
4 1/2 to 6 in.	63 1/2	56 1/2
7 to 8 in.	56 1/2	46 1/2

XX Strong P. E.

1/2 to 2 in.	43	33
2 1/2 to 4 in.	43	33

WROUGHT IRON PIPE.

The following are Montreal jobbers' discounts on pipe. (Card weight) in effect from October 11th, 1912:

	Standard	Buttweld Black Gal.	Lapweld Black Gal.
1/4 3/8 in.	64	49
1/2 in.	69	59
3/4 to 1 1/2	73 1/2	63 1/2
2 in.	73 1/2	63 1/2
2 1/2 to 4 in. ...	73 1/2	63 1/2	72 1/2
4 1/2 to 6 in.	74	64
7, 8, 10 in.	70 1/2	58 1/2

X Strong P. E.

1/4, 3/8	64	49
1/2 in.	65	55
3/4 to 2 in. ...	69	59
2 1/2 to 3 in. ..	69	59
3 1/2 to 4 in.	66	56
4 1/2 to 6 in	65 1/2	58 1/2
7 to 8 in.	60 1/2	50 1/2

XX Strong P. E.

1/2 to 2 in. ...	44	34
2 1/2 to 4 in	44	34

IRON PIPE FITTINGS.

Canadian malleable, 40 per cent.; cast iron, 65; standard bushings, 70; headers, 60; flanged unions, 65; malleable bushings, 65; nipples, 75; malleable, lipped unions, 65.

COKE AND COAL.

Solvay Furnace Coke	\$5.25
Solvay Foundry Coke	6.50
Connellsville Furnace Coke	5.50
Connellsville Foundry Coke	6.00
Yough, Steam Lump Coal	3.83
Penn. Steam Lump Coal	3.63
Best Slack	2.95
All net ton f.o.b. Toronto.	

OLD MATERIAL.

	Tor'to.	Mont'l.
Copper, light	\$11 00	\$10 50
Copper, crucible	14 00	13 50
Copper, unrec'bled, heavy	12 00	12 00
Copper wire, unrec'bled..	12 00	12 00
No. 1 machine compos'n..	11 00	11 00
No. 1 comps'n turnings..	10 00	10 00
New brass clippings	9 00	9 00
No 1 brass turnings	7 50	7 50
Heavy lead	3 25	3 00
Tea lead	2 50	2 75
Scrap zinc	3 50	3 25
Dealers' purchasing prices.		

SMOOTH STEEL WIRE.

No. 6-9 gauge, \$2.35 base; No. 10 gauge, 6c extra; No. 11 gauge, 12 extra; No. 12 gauge, 20c extra; No. 13 gauge, 30c extra; No. 14 gauge, 40c extra; No. 15 gauge, 55c extra; No. 16 gauge, 70c extra. Add 60c for coppering and \$2 for tinning.

Extra net per 100 lb.—Spring wire; bright soft drawn, 15c; charcoal (extra quality), \$1.25.

METALS.

Prices in cents per pound:

	Mont'l.	Tor'to.
Lake copper	16.00	15.75
Electrolytic copper	16.00	15.75
Spelter	6.00	6.00
Lead	4.30	4.50
Tin	50.00	50.00
Antimony	10.00	9.75
Aluminum	23.00	23.00

SHEETS.

	Mont'l.	Tor'to.
Sheets, black, No. 28....	\$2 85	\$3 00
Canada plates, ordinary, 52 sheets	2 80	3 00
Canada plates, all bright.	3 70	4 15
Apollo brand, 10¾ oz. (American)	4 30	4 20
Queen's Head, 28 B.W.G..	4 50
Fleur-de-Lis, 28 B.W.G..	4 20
Gorbal's Best Best, No. 28	4 45
Viking Metal, No. 28....	4 40

NAILS AND SPIKES.

Standard steel wire nails, base	\$2 40
Cut nails	\$2 60	2 65
Miscellaneous wire nails..	75 per cent.	
Pressed spikes, 5/8 diam., 100 lbs.	2 85

FINE STEEL WIRE.

Discount 25 per cent. List of extras.
In 100-lb. lots: No. 17, \$5; No. 18, \$5.50; No. 19, \$6; No. 20, \$6.65; No. 21, \$7; No. 22, \$7.30; No. 23, \$7.65; No. 24,

\$8; No. 25, \$9; No. 26, \$9.50; No. 27, \$10; No. 28, \$11; No. 29, \$12; No. 30, \$13; No. 31, \$14; No. 32, \$15; No. 33, \$16; No. 34, \$17. Extras net. Tinned wire, Nos. 17-25, \$2; Nos. 26-31, \$4; Nos. 30-34, \$6. Coppered, 75c; oiling, 10c.

MISCELLANEOUS.

	Cents
Putty, 100 lb drums	\$2.70
Red dry lead, 560 lb. casks, per cwt.	6.25
Glue, French medal, per lb	0.10
Glue, 100 flake	0.11
White lead, ground in oil, No. 1 pure, 100 lbs.	8.40
Tarred slaters' paper, per roll...	0.95
Motor gasoline, single bbls., gal..	24½
Benzine, per gal.	23½
Pure turpentine	64
Linseed oil, raw	58
Linseed oil, boiled	61
Plaster of Paris, per bbl.	2.10
Plumbers' Oakum, per 100 lbs..	4.25
Pure Manila rope	17

The General Market Conditions and Tendencies

This section sets forth the views and observations of men qualified to judge the outlook and with whom we are in close touch through provincial correspondents.

Montreal, Que., March 31.—Last week showed a good volume of business in machine tools, and dealers continue highly satisfied with existing trade conditions. The National Transcontinental Railway Commission placed orders during the week for a large amount of machine tool equipment for their round-houses from Moncton to Winnipeg. The business was distributed amongst several dealers, one prominent firm receiving orders to the extent of \$18,000. The Dominion Bridge Co. also placed orders for a considerable amount of equipment for their various plants. Mr. Henry M. Sonenthal, managing director of the Selson Engineering Co., Ltd., London, England, arrived in town today. It is his intention to appoint a Canadian agent for the well-known line of "Selson" machine tools.

Pig Iron.

The pig iron situation remains practically unchanged. English pig shows no immediate signs of becoming easier, prices for delivery at the opening of navigation ruling firm at about \$21.50 for Middlesboro No. 3 on the wharf at Montreal.

Metals, Etc.

Copper last week was rather firmer, Lake copper being now quoted at 16 cents per pound as against 15.75 cents a week ago. Lead and tin also show a

firmer tendency, with comparatively small supplies in sight. Connellsville foundry coke fell several points and is now selling at \$2.25 at the furnaces, this making the price about \$6.00 f.o.b. Montreal. The serious floods in Ohio and around Pittsburgh which are only now beginning to subside will have a very bad effect on the present steel situation. It is estimated that fully 100,000 iron workers have been temporarily thrown out of work and that the production of pig iron in the United States will have been reduced by at least half a million tons. The loss of production in finished rolled iron and steel is estimated at almost as great a tonnage.

Toronto, April 1.—Things are quiet in the machinery market. March is unusually quiet. Our railways still continue to buy heavily, which is a good sign. The C.P.R. sent out specifications last week for machine tool equipment for their new shops at McAdam Junction, N.B. The National Transcontinental Railway is also purchasing machinery, A. R. Williams & Co., having received orders for a lathe for Parent, Que., and a lathe and planer for Moncton, N.B.

Richard A. Shields, a New Yorker, was in Toronto during the week and gave the A. R. Williams Co. an order to equip a repair shop for motor boats, etc.

at Port Sandfield, Ont., in the Muskoka district. The order called for lathes, drills, grinders, etc. The Canadian Fairbanks-Morse Co., had an unusually good demand last week for oil engines from small manufacturers.

Pig Iron.

With the weakening in pig iron across the border, prices fell in Canada, the drop being 25 cents a ton. Sales did not amount to anything. Drummond-McCall & Co., are now selling Foundry Nos. 1 & 2 f.o.b. Midland at \$19 a ton in large quantities. A bigger volume of business may be expected next month. Considerable business was done at Pittsburgh last week in basic iron, and some relatively low prices have been made. Dealers, here, in English pig iron, who have previously handled 75 per cent. of the trade, declare that very little will cross the Atlantic in 1913, owing to the high price asked. Cleveland and Clarence used to sell well here, but prices now are not even being quoted.

Tubes, Wire, Sheets, Etc.

There was an advance of a dollar a ton in wire products across the line last week. Prices may be expected to advance here in both wire and nails. The Steel Co. of Canada increased the price of wood screws last week, the discount now being 85. 10 per cent. off, for flat-head, bright, against 85. 10. 7½ per cent. off previously. This advance applies to wood screws right through. Tubes are still in great demand for marine repair work, and prices may be expected to advance again in a week or so. There was a big plate buying movement

caused by the wind storm last week, many stacks being blown down. Business in sheets is quiet, with prices firm, though there might be a slight drop before long. American mills are booked up, and specifications are coming in freely. A change was made in the price of small shapes, Toronto warehouse, from 2.45 cents to 2.40. The price for plates, warehouse import, freight and duty to pay is now 2.05 cents per lb., instead of 2.15 cents.

Metals.

Tin rose from 49 to 50 cents a lb. this week. Other prices remain the same. The Canada Metal Co. report big business in old materials, far ahead of that of last year. March has been a better business month than a year ago.



NEW MOTOR STARTING DEVICE.

S MALL pump motors, etc., are sometimes connected in series with a resistance permitting a current rush on starting of about four times the full load current. The resistance remains permanently in circuit and the motor horse-power is reduced about 20 per cent. A German firm, however, has recently devised an arrangement which consists of an iron wire spiral mounted in a hydrogen-filled bulb fitted with an Edison screwed socket. For a 2 horse-power 220-volt motor, the resistance is 2.4 ohms cold and attains a maximum value of 26 ohms after about 0.8 seconds. On a 110-volt circuit, the cold resistance corresponds to a starting current of 46 amperes, but, owing to the small heat capacity of the wire, it is impossible to obtain a higher starting current than 31 amperes. As the motor gains speed, the resistance is automatically short-circuited. The motor then develops full speed and output.

In direct-current circuits the device is connected in series with a small constant resistance, but this is unnecessary in three-phase circuits. In direct-current circuits the device is designed for half the line voltage. Two sizes are made, 330 and 500 watts respectively. Automatic direct-current starters of this kind are made up to 8 horse-power capacity. In small starters, the starting relay controls the short-circuiting of resistance in accordance with the armature voltage, but in larger units the resistance is short-circuited in sections at fixed time intervals.



Moose Jaw, Sask.—The Frampton Soap Co., Seattle, has decided to open a factory in Moose Jaw, and will build this spring. Its capitalization is \$100,000.

Classified Advertisements

* Those who wish to sell or buy a business, obtain competent help, connect with satisfactory positions, or secure aid in starting new enterprises should not fail to use the Want Ad. Page of "CANADIAN MACHINERY."

* If you want to sell or buy a second-hand lathe, planer or any other shop equipment, let "CANADIAN MACHINERY" pick out a seller or buyer for you. How about that second-hand engine or boiler which you would like to dispose of?

* "CANADIAN MACHINERY" is the central market place of the machinery trades throughout Canada.

* There is always some one looking for just such proposition as you have to offer.

Rates (payable in advance):—2c per word first insertion, 1c per word subsequent insertion, 5c additional each insertion when Box Number is required. Each figure counts as one word.

Classified Advertisements

FOUNDRY SUPERINTENDENT

WE HAVE AN OPENING FOR A FIRST-class foundry superintendent for an up-to-date stove plant. Must be a man capable of producing at a minimum cost, thorough in melting, mounting, fitting and finishing. Apply, stating experience, references and salary expected, to Box 7, Canadian Machinery, Toronto. (12)

MACHINISTS WANTED

MACHINISTS WANTED — FIRST-CLASS lathe and planer men and fitters. Good wages paid to first-class men. Apply to William Hamilton Company, Limited, Peterborough, Ontario. (12)

DRAUGHTSMAN WANTED

WANTED, MECHANICAL DRAUGHTSMAN. Must have good general knowledge of machine design for sawmill and pulp mill machinery. Apply, stating age, experience and salary expected, to William Hamilton Company, Limited, Peterborough, Ontario. (12)

SUPERINTENDENT WANTED

ASSISTANT SUPERINTENDENT WANTED for Bolt and Nut Department of large manufacturing company, to look after execution of orders, etc. Must have had experience in this line. Apply giving references and salary expected to Box 124 Canadian Machinery, Toronto. (12)

DIES AND TOOLS POWER PRESSES

For Rapid Production of
Sheet Metal Stampings

W. H. BANFIELD & SONS
TORONTO, ONT.

PATENTS TRADE MARKS AND DESIGNS

PROCURED IN ALL COUNTRIES

Special Attention given to Patent Litigation
Pamphlet sent free on application.

RIDOUT & MAYBEE 59 Yonge Street
TORONTO

Morton Manufacturing Co.

Draw Cut Shapers.
Special Draw Cut
R. R. Shapers,
Special Locomotive
Cylinder Planers.

Portable Planers.
Stationary & Portable
Key Way Cutters,
Finished Machine
Keys.

Office & Works, Muskegon Heights, U.S.A.

TRADE MARKS, COPYRIGHTS & DESIGNS PATENTS

LLOYD BLACKMORE & COMPANY

LUMSDEN BUILDING, TORONTO.
ALSO, HOPE BLDG. OTTAWA, & WASHINGTON, D.C.
We have an interesting and valuable booklet "PATENT
PROTECTION" which will be sent free upon request.

PATTERNS WOOD AND METAL

Allow us to estimate. Satisfactory
work guaranteed.
TAYLOR PATTERN WORKS WALKERVILLE, ONT.

STAMPINGS

Special
Manufacturing
to Order

No matter how hard a stamping problem you put up to us, the chances are we can satisfy you. Many people use stampings in place of castings and find them more satisfactory and often cheaper. Send blue prints and samples and let us quote you.

The Silent Partner is an interesting little magazine. We send it free—when there's a reason

THE GLOBE MACHINE & STAMPING CO.
899 Hamilton Street, Cleveland, O.

Design and Construction Features of Modern Shop Cranes

By F. W. Suffield

Cranes, perhaps, more than any other accessory detail of the equipment of our engineering and general manufacturing plants, contribute to secure the efficient, safe and economical output of product, while, at the same time, reducing to a minimum the call for physical exertion on the part of the individual employees. This article deals in a general way with the subject, and the various questions raised and discussed will be found interesting and instructive.

THE jib crane, on account of its almost universal employment, will be the first type to be considered under the subject heading of this article, and of the many varied arrangements adopted for different shop services, the simple underbraced type is the most common: it, therefore, I have selected for featuring purposes. In designing this particular type crane, we must, first of all, know the live and dead loads which it will have to handle and carry, and then proceed to set out the stress diagrams. A typical crane used in shops over machines and in foundries, fixed against a wall or on a column, consists of a mast or pillar resting on a foundation and supported at the top. The jib fixed to the mast or pillar is supported by a strut attached to the pillar.

First, we must know the load which is put on the crane delivered to the jib by the four wheels. The overhang or cantilever is usually about a quarter of the distance between the column and the point at which the strut is connected to the jib. When the load is at the centre or at the end of the cantilever, the bending moment is practically the same. This ratio should be so proportioned as to produce the same stress in both cantilever and span. The next step is to obtain the reaction at the junction of the strut and the jib, and the jib and the column. We then draw a parallelogram of forces to a force scale, and measure the lines to obtain the forces for the required sections.

Jib cranes for workshops and foundries are, as a rule, hand-power operated, but the introduction and development of the electric motor, which has revolutionized so many of the methods of manufacture and transportation, has perhaps influenced the design of no other auxiliary apparatus so much as that of the crane. There are some fixed jib cranes in railway shops driven by electric motors, but these are not general. A very useful pattern of jib crane travels on one rail, and is known as the walking crane.

Overhead Travelling Cranes.

The simplest application of electric motors to an overhead lifting and travelling application, is when the carriage is suspended and run on the bot-

tom flange of rolled steel joists, which are suspended in their turn in the shops over machines or work where lifting is required. Runways of this description are much used in small foundries and loading warehouses.

The overhead travelling crane in its various forms is probably in greater demand than any other type of crane on the market. It has induced many firms to specialize in crane building, and the demand has enabled them to standardize many of the parts. Electrically-driven overhead cranes are those most universally adopted for heavy loads, especially when continuous running and rapidity are required. The three motor crane is the most efficient for modern workshop practice, but, until recently, the single motor crane was considered the cheapest for engine houses and places where only an occasional lift was required. Considerations of the present price of motors and that single motors require more gearing, are two reasons for preferring three motor cranes.

One of the principal obstacles which make standardization difficult is the varied opinion as to speeds. In selecting a given speed of lifting load, it should not be overlooked that the nominal load is seldom more than 20 per cent. of the full capacity of the crane. It is better, therefore, to consider the highest and safest speed at which this load can be worked, and then select a full load speed which will give the same foot tonnage of work done. By the use of series-wound motors, a variation above the rated speed of about 50 per cent. increase, proportional to the load, can be obtained; it is therefore unnecessary to use change gears on the main lift. On the cranes, say, over 20 or 25 tons, where the full load is only occasionally handled and the crane is used frequently for light loads, it is often economical to have an auxiliary barrel fitted, and worked by a separate motor with a capacity of 5 to 6 tons, and a speed of 20 to 40 ft. per minute, the lift being 1-5 th of the full capacity of the crane and the speed such as will give the same foot-tonnage as the main lift. It is never worth while having a change of gear to the cross traversing and travelling motors. The speeds are variable according to the work required to be done.

Obtaining Horse Power of Motors.

The lifting motor depends purely on the work done on the load and the power absorbed in the friction of gearing, journals, etc. It varies with the number of reductions and the type of gearing. A common rule in practice is to allow 10 ft.-tons of work done at the hook per B.h.p., being equivalent to a mechanical efficiency of about 66 per cent. This is very near for medium or large cranes, but, for smaller sizes, it allows a slightly larger motor than is really necessary, which is perhaps a good fault, as the smaller cranes are in more constant use.

The power required for cross traversing and travelling must be sufficient to overcome the rolling and axle friction and the friction of the intermediate driving gear. For practical purposes the resistances of 40 to 50 lb. per ton for cross traversing, and 60 to 70 lb. per ton for travelling are allowed for the best class of travelling cranes which have large diameter wheels and machine cut gears.

Framing and General Details of Crabs.

The difference in appearance is chiefly in the design of the crabs themselves. There has been a difference of opinion as to the materials adopted, some makers using cast iron frames up to very large sizes. It is now almost universal, however, to use a steel framing for all sizes. The chief idea in designing is to make all parts as accessible as possible for removals, repairs and general attention, and to keep the structure as light as possible with stability. Some makers use steel plates either double or single, but these box up the motors and gearing too much, and perhaps, what is worse, necessitate solid bearings.

In calling attention to the crabs of motor cranes with cast iron and steel channel section frame of modern design it may be pointed out that all the bearings are adjustable except those of the axles of the running wheels, which are generally bushed. In designing the framing for these crabs, it is almost impossible to give definite calculations as general rules, but care must be taken that the stress limit does not exceed 5 tons per sq. in. to avoid possible deflection or bending of shafts.

In crabs for light cranes it is difficult to design a stiff enough frame without putting more material in than is required for actual strength.

Wheels and Axles.

The running wheels and axles are the first to be considered, and the material from which the former are made is important. For first-class work, cast iron should not be used above 10 tons, as the weight is considerable that they are required to carry, and they will soon show signs of wear; they should, therefore, be of cast steel. The wheels should be made as large as possible, in order to reduce the tractive resistance. The axles, again, should be made as small as possible, but must have care given them, as they are subject to combined bending and twisting, due to overhang, and to resistance of traction. The overhang from centre of bearing to centre of wheel should not exceed 5 in., and the working strain should not exceed 5.5 tons per square inch.

The length of the bearings should be so designed as not to give more than 900 lb. per square inch of projected area. They are usually of cast iron with brass bearings on top. The most important part is the lubrication, and for crabs over 40 tons, self-oiling ones should be adopted. Roller bearings are occasionally used for heavy cranes. Sometimes, for very heavy crabs, the axle bearings are put on both sides, enabling less width in bearings to be adopted and more compactly arranged gearing. One wheel on each side would require to be geared with this arrangement.

Rope Details.

The barrels are made usually of cast iron, and the rope grooves turned in to suit the diameter of rope to be used. Particulars of steel ropes suitable for this work are appended, and can be taken approximately:

Loads in Tons.	No. of Ropes.	Circum. in Inches.
3	2	1 $\frac{3}{4}$
5	2	2 $\frac{1}{4}$
7.5	4	4
10	4	2 $\frac{3}{4}$
15	4	3 $\frac{1}{4}$
20	4	3 $\frac{1}{2}$
25	4	4
30	4	4 $\frac{1}{2}$
40	4	5 $\frac{1}{2}$

The usual factor of safety is 8, which allows a good margin over, if a few strands break. The life of a rope depends largely on the diameter of the barrel and the number of pulleys it passes round. Some makers recommend 6 $\frac{1}{2}$ times the circumference of the rope. This appears suitable for ropes under 3 $\frac{1}{2}$ in. circumference, but above this, 5 $\frac{1}{2}$ to 6 should be quite large enough

for the barrel. An important point is the spacing of the ropes on the barrel—that is, the centres of the grooves. For all ropes up to 4 in. circumference, $\frac{1}{8}$ in. should be left between the sides of the ropes, but above that size, 3-16 in., if possible. This is to allow for the flattening of the ropes while under load, and to avoid their grinding together. The usual practice is to allow the lift to be taken in the centre of the barrel, so as distribute the load more evenly on the girders. From 7 to 50 tons, the load should be lifted on four parts of the rope—that is, two parts in right and left hand grooves on the barrel; the other end passing round a pulley. This pulley need not exceed twice the circumference of the rope.

For cranes up to three tons, the load should be lifted in a single pull of rope; 5, 6 and 7 tons with two ropes, one coil being on the barrel; four ropes up to 50 tons, six to 75 tons, and so so. It is not so important to lift centrally with small cranes, as the load on the girders can never exceed the strength of the material used, and it always must be in excess of requirements. The thickness of metal in the barrel should be considered, as the stress of bending must not exceed 75 tons per square inch, this giving ample strength. The barrel shaft is dealt with in the same way as other shafts, also the bearings with the same bearing pressure.

Gearing.

Gearing is one of the most important parts of the crane design. It is quite within the writer's memory that machine cut teeth were a very special thing, and that practically all gear wheels were cast, and for special purposes machined afterwards. Since, however, the introduction of electric motors and high-speed machines, cut gears became necessary. Although machine cut gear for crane work increases the cost of the machine, the saving of current in electric motors is considerable, and can scarcely be over-estimated, so cut gears soon pay for themselves.

For heavy loads, it is usual to have cast-iron for the barrel gear and pinion, because it is advisable to shroud the pinion, and the speed being low, the loss due to friction is not worth considering. Raw hide motor pinions are found to be suitable for the first reduction up to twenty tons, this, of course, gearing into cast iron. These run very smoothly, and do not require lubricating. Above twenty tons, the motor pinions ought to be machined steel running with cast iron or steel wheels in an oil bath. It is usual to make the steel pinions from a solid steel bar or forged piece. The barrel wheel and pinion up to 20-ton cranes are made in cast iron, but above

this, cast steel is better, and in all cases above 7 tons the pinions must be shrouded. For cranes above 20 tons, it is good practice to make all the pinions of steel. Altogether, the sizes of the pinions should be as small as possible, but no pinion should have less than twelve teeth.

Strength of Teeth.

In crane work, as in all other gearing, the strength of the teeth is most important, and the question of the stress to which these are subjected is very variable in actual practice. The average ultimate strength of cast iron and cast steel subject to bending (as in a tooth) is 18 and 30 tons, respectively. Due to the nature of the metals and the methods of manufacture, one would be justified in allowing a factor of safety of 8 for cast iron and 6 for cast steel for slow running.

Reliable formula, such as Professor Unwin's, would be found quite satisfactory in use. Involute teeth with radial flanks, which give a short tooth with a broad root, are most often used because of their great strength. Some makers shroud the barrel gear and pinion to the pitch line, but if the calculations are taken at this point the object is defeated. The chief value of shrouding is to minimize the tendency of the teeth breaking across the corners, especially cast iron ones.

Double helical gears are sometimes used for cranes, say, over 30 tons, on the barrel and pinion. The relative strength to spur gear is a debatable question, but as the points of contact are always distributed over the whole of the working face, from root to point, the whole leverage of the whole load is only half that of ordinary spur gear. In practice, it is very difficult to make the apices of these gears run in the same plane, any error in this respect causing the load to be on one side of the wheels, so that care must be taken in working out the strengths not to accept too liberally the advantage that double helical-shaped teeth have over the ordinary ones, although they are about 1 to 1 $\frac{1}{2}$ times stronger. The question of the design and strength of the arms, rims and hubs must also be gone into carefully.

Brakes.

Electric-driven cranes must be fitted with effective brakes, and of these there are two kinds—magnetic and mechanical. The magnetic brakes are generally ordinary strap or clamp brakes, which are held off by a magnet or solenoid connected with the motor, so that when the current is taken off, the brake comes into action. To avoid a too rapid action, the solenoid forms in itself a dash pot, the air being throttled in a small hole at the top of the body. It must be suffi-

ciently strong to hold the full load in the event of the mechanical brake failing. When both brakes are applied, the solenoid is almost solely used for stopping the motor rapidly, and as it will run both ways, the cramp type of brake is most suitable. Brake pulleys on the motors should be as large as possible, yet the peripheral speed should not exceed 2,000 to 2,500 ft. per minute.

Girders.

The consideration of the main girders, and the selection of their type for a given crane is an important point, since the general efficiency of the crane is affected. Further, if it is to be a competitive machine, economy has also to be taken into consideration, while relative design to the working stress has to be carefully attended to. A wide variation of opinion exists among makers as to the basis of working stress by which they design their girders. We find frequently that firms whose designs are the most expensive and elaborate work on 4 tons per square inch, whereas others, whose aim is to meet the demand for the cheapest crane, work on 7.5 tons per square inch, or even higher. My opinion is that for a good sound result, 5 to 5½ tons per square inch should be the limit, and this will cover all contingencies and avoid all undue deflection in the shafts, etc.

Types of Girders.

There are four principal types of girders:—(1) Rolled steel joists; (2) box plate girders; (3) single web plate girder; (4) braced or lattice girders.

1.—The rolled steel joists is, of course, the simplest type of girder, and is frequently used for spans up to 40 ft. for light loads, and 30 ft. span up to, say, 20 tons.

2.—For cranes above 15 tons in spans up to 65 ft., box girders are considered excellent, but they are at a great disadvantage, inasmuch as that they cannot be got at for painting inside. The sections and proportions required for such loads generally ensure the girder being stiff enough without causing any lateral distortion.

3.—For cranes up to 15 tons, and up to 40 ft. span, where rolled steel joists are not stiff enough, the single web plate girder can be made economically with one or two provisions, such as that the speed must not be excessive. Platform girders should be added and braced horizontally to the main girder.

4.—For cranes up to and including 4 tons, above 40 ft. and up to 65 or 75 ft. spans, braced girders of all descriptions are the most economical. They are cheaper to make, are less in weight, and consequently use less power. The most important thing is to adopt the right kind of bracing for each specific case.

From the points of cost, weight, and convenience, the Warren type is best. Where the rolling load is large and heavy in portion to the structural load, the double or partly double lattice girder is adopted.

Girder Calculations.

The first step in calculation of crane girders is to obtain the bending moment in the ordinary way. This must include the forces due to (1) rolling load; (2) weight of crabs; (3) structural load—that is, weight of girder, platform and cross shaft. (4) If the driving motor is in the centre this must be added. I do not propose to consider impact forces in any one case, as these are often neglected by crane builders, although, in my opinion, something should be added, especially for high-speed cranes. If it were bridges I was designing I should take into consideration this force, as being as much as 50 per cent. of the actual rolling load.

If the crab is symmetrically built, the rolling load may be considered as being divided equally on the four wheels; consequently, it shortens the effective span of the girder by the distance of the centres of these wheels. This bending moment of the rolling load is obtained by multiplying the reaction at either support by the distance from that support to the centre of the crab wheel nearest the support.

The bending moment, due to the structural load, is found in the usual way for a distributed load.

W.L.

M.B. = ——— and that of the

S

driving motor as a concentrated load

W.L.

M.B. = ———

4

These can be obtained by diagrams, but it will simplify the matter if we can develop them as follows: Assuming a crane of 25 tons, 50 ft. span, with a crab of 5 tons carried on a wheel base of 5 ft., and that the girder, platform, etc., are 5 tons, and the travelling motor ¾ tons.

B.M. Rolling Load = 270 in. by 7.5 = 2025 in. tons.

5×600

Structural = ——— = 357 in. tons.

8

3×600

Motor = ——— = 112.5 in. tons.

4 by 4

Total 2512.5 in. tons.

The next question is the depth. For crane work, one-twelfth to one-sixteenth is adopted, according to the size. For heavy loads, it is more economical to increase the depth than to make the flanges heavy. We must first assume a suitable section, and then proceed to ob-

tain the moment of inertia, which must be taken about the neutral axis, this being for rectangular symmetrical sections one-twelfth multiplied by the breadth, multiplied by the height cubed. The modulus of a symmetrical section is equal to the moment of inertia divided by the distance from the neutral axis to the extreme outer edge of the section, and this must be equal to the bending moment divided by the working stress.

The web-plates should not be less than ¼ in. thick under any circumstances to allow for deterioration, and for box girders these can be used up to 20 tons; 5-16 in. for 30 to 50 tons, and ¾ in. above these loads. For single web girders, ¼ in. plates can be used for cranes up to 7 tons, 5-16 in. up to 20 tons, and ¾ in. above. These are only approximate, and require in some cases stiffeners, usually T-iron, spaced about 4 ft. to 5 ft. apart. It is quite unnecessary to have the full length of the girder of equal depth; if being usually made "fish-bellied," or with the bottom flange made polygonal, the angles occurring where the stiffeners come.

Lateral Stresses.

For high-speed cranes, we must consider lateral stresses, due to suddenly stopping the load. If we take the previous example, and assume it runs at 300 ft. per minute, equal to 5 ft. per second under full load, the momentum of load and crab at full speed will be 30×5

———— = 11.6 ft. tons. If we assume the

64.4

crane travels 5 ft. after the current has been cut off and the brake put on, the horizontal force on the two girders

11.3

would be ——— = 2.3 ft. tons, giving 1.15

5

tons per girder. To this must be added the distributed effort as well, which would equal about .95 on the same formula.

We must, therefore, see that the total lateral stress does not exceed four tons per square inch under these conditions, so as to avoid any possibility of distortion from the concentrated load. It is quite obvious that the girders might fail this way and yet be amply strong to carry the load in the span, but the fixing of the platforms often assists very materially to overcome the difficulty.

The details of the Warren and lattice type vary somewhat with the size of crane, but the stresses to be considered first are found in the same method as we have already seen for all conditions. This kind of framed structure is composed of a compression and a tension flange, kept in position by diagonal members, which are subject to compression and tension alternately as the load moves along. In order to minimize the

extra load which the top flange is subject to on account of the crab wheels, a vertical member is inserted to reduce the spans between the diagonals. These girders can be made parallel or fish-bellied, according to idea and appearance. If made parallel the member could be reduced in section, or kept the same section if the depth were altered. The stresses may be obtained either by moments or diagram, but for the purpose of this paper the author adopted the latter, explaining, however, that in actual practice he prefers to check his diagrams by moments.

It is economical design to use as few sections as possible, taking the maximum stress and using the same section throughout the length. A sufficient number of rivets should be allowed for at the joints to limit the shear stress to 5 tons per square inch and $8\frac{3}{4}$ tons per square inch of bearing. The end bay should be plated in to stiffen the girder and meet the required shearing stresses.

End Carriages.

In order to calculate the strength of the end carriages we must know the load of the crab at the extreme end, to which must be added the weight of the girders themselves. It is also necessary to fix the centre of the girders and the travelling wheels. The first depends upon the requirements of the crabs, and the second should be about one-fifth of the span. Channels are most convenient, or plates and angles. The wheels should be from 18 in. to 30 in. in diameter, according to the size of the crane, and of cast steel or cast iron with steel treads. The toothed wheel should be by preference bolted to the wheel, rather than keyed separately or cast in one piece.

One of the greatest objections to the cheap crane is allowing these wheels to be bushed and run loose on the spindles, being among the many bad features adopted to cheapen the cost of a marketable crane.

Platforms.

The platforms may add to or detract from the appearance of a crane and it is very largely a matter of opinion as to where there shall be one, two, or none at all. For light cranes, when rolled steel joists are used for the main girders, four girders are fitted, and wood battens laid between the two outside members. For light lattice or single web girders it is found cheapest to form light subsidiary girders and fix to main girders with diagonal bracing, so as to increase the lateral stress. In some cases of this description, the top plate of the girder can be extended to form the platform of chequered plate, which practically strengthens the construction. When the crane girders are stiff enough, brackets

can be carried on the sides of them, and these must be designed in uniformity with the remainder of the work. Timber is used for this purpose on account of its cheapness and lightness.

The cab is made of very light construction, and suspended from the end of the main girders. It should be just large enough to contain the controller, switches, and room for the driver to sit down. Lubrication is a very important point, and every facility must be made for fixing lubricators when oil baths are impossible.

As to progress through the works, the material is usually ordered from the mills in lengths and sizes suitable for the particular order as far as the plates are concerned, and the bar material in lengths of 30 ft. or 40 ft. The detail drawings are taken into the template shop and all the templates made, from which the required material is marked off for drilling, punching, trimming, and cutting to lengths.—Abstract of paper read before the Birmingham Association of Mechanical Engineers.



G.T.P. CONSTRUCTION.

WESTERN advices state that the steel which is being laid on the Grand Trunk Pacific Railway from Tofield to Calgary, a distance of about 200 miles, has now reached the Bow River on the outskirts of the latter city. Previously the steel gang and outfit cars had been stationed at Hubalta, some six miles east of Calgary but will now be taken back to Irricana where a gravel pit will be opened and ballast laid along the tracks as far as the river.

The Dominion Bridge and Steel Co. will at once commence to erect the large steel bridge over the Bow which, it is expected, will take about four or five weeks to complete. The G.T.P. survey staff under Mr. L. J. Devereux, resident engineer of Tofield, is now surveying between the river and the city. A temporary station will be erected immediately and other terminal facilities will follow as soon as possible.

In about three week's time, work will be started on the Biggar-Calgary Branch line, thus opening up a vast area of farming country. Some 40 miles of steel was laid in this line last summer and this portion will, it is understood, be ballasted immediately, so as to allow passenger and freight trains to run as far as Fort Saskatchewan. The whole work will be rushed as fast as possible.



ADVERTISING.

IN a paper read recently before the Royal Society of Arts, the author gave expression to the following ideas and opinions:

"I am not an accountant, but I have no doubt that every accountant approves the spreading of the cost of an advertising campaign over a term of years. No one can pretend that the whole value accrues at the moment the money is spent, and as the business grows under the influence of advertising, so, too, does the goodwill. Starting his appropriation on a settled capital sum, an advertiser can increase that sum yearly if he so desires from a sum allocated from the increased profits due to increased business, so that if he is content to move along steadily he can build up his appropriation as he goes along. I would warn, however, newcomers to the advertising field to be most careful not to incur greater advertising liabilities than they can afford. Let them keep on the safe side of the hedge and gradually extend their operation as wealth is gained.

Increased Value Feature.

Taken all round, I think that everyone agrees that advertising grows better and better every month. Pre-advertising, as a whole, is more interesting and rings truer; it is, therefore, more convincing than of old. The price list and catalogue have also improved out of all knowledge, and contain more information, and are more tastefully got up and printed than of yore. The future for advertising, in my opinion, is bright, and competition of a healthy type will only quicken its pulse and help it to grow in power and efficiency.

Not a Science.

I need scarcely point out that every advertising problem needs separate treatment; there is no royal road to success, and to that extent advertising is not, at the moment, an exact science. Pray Heaven, moreover, that it never may be. Should that remote possibility happen, then advertising would be shorn of most of its vitality, vigor and power. The study of the scientific application of the principles of advertising should, however, be encouraged in every way possible, and the results carefully noted, checked and examined, in order that true and proper deductions may be arrived at. It is only by the constant observation of cause and effect in advertising that we can improve as advertisers.



Montreal, Que.—Tenders will be received to April 15 for the construction of a diversion of the C.P.R. main trans-continental line starting from mile 69 Mountain division, which is one mile west of Six Mile Creek, B.C., and ending at Mile 92, two miles west of Camble, mileage 89 on the new line.

Typical Methods of Attaching Chucks to Lathe Spindles*

By Fred Homer

The manner in which a lathe chuck is attached to its spindle has a vital influence upon the accuracy of a considerable portion of the work which is turned and bored in a lathe. Again, numerous adaptations of chucks purchased from manufacturers are required to suit individual cases. The article deals with the principal points involved.

ATTACHMENT OF LATHE CHUCKS.

THE present article is a continuation of that which appeared in our April 3 issue, and deals with special back plate and locking device features.

Special Back-Plates.

When a spindle nose is of large diameter, the ordinary kind of back-plate cannot be employed, and a different form of adapter fitting is necessary to reduce the diameter suitably for accom-

modating the chuck. In ordinary lathe operations, where the chuck has a simple plate only and not a box body, studs may be set into the adapter, and nuts be placed on the chuck front. An adapter for a chuck of normal capacity is represented by Fig. 12; clearing holes being required in the flange opposite the respective screws to enable these to be inserted.

Locking Devices.

Although in ordinary lathe work there is no occasion to reverse the direc-

tion of the spindle end, or the adapter can be modified to include a pair of locking screws, fig. 13, which are set down on the shoulder of the spindle. This method is applied to chucks for brass-finishing and screwing. A guard should be placed over the adapter to prevent accident from the flying screw-heads. The latter, of course, may be sunk, or hollow set-screws be employed instead.

An exceptional ease of fitting is that followed in some classes of cutting-off lathes and machines, in which a chuck is located on the back end of the spindle simply to centre the bar. Here, it is enough to slip the chuck on a plain portion, and secure it with a set-screw or two, fig. 14.

BUILDING FOR PLANT REQUIRED.

AN American manufacturing concern intend to establish a branch in Canada, and are seeking a building of one or two storeys, with a total floor space of from 7,000 to 10,000 square feet and a yard of 50 to 60 feet square in addition. The building may be of mill construction, and capable of supporting a live load of 100 to 125 lbs. per sq. ft. A small supply of power would be necessary, and supply of 100,000 cubic feet of illuminating gas per month.

The firm manufacture small tools, and require a plant which could be running by July 1. Industrial Commissioners should advise Canadian Machinery if such a building is available in their city.

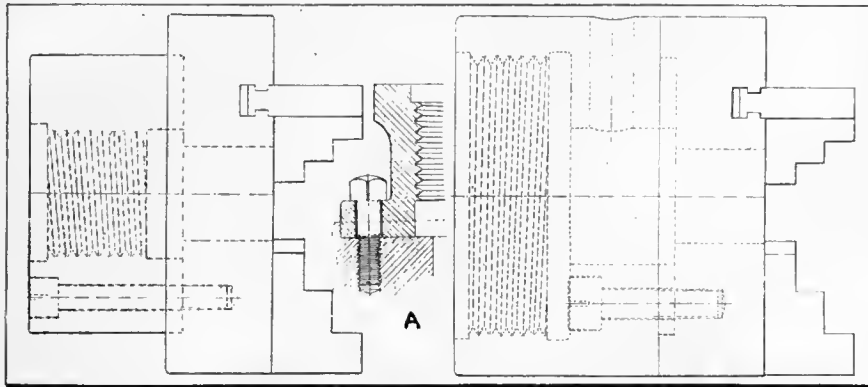

FIG. 9. FIG. 10.
TYPICAL METHODS OF ATTACHING CHUCKS TO LATHE SPINDLES.

modating the chuck. Such a reducing adapter is illustrated in Fig. 9, and consists of a cylinder with screws put through from the back. The detail (A) represents an arrangement of screws which is an alternative, a slight flange being formed and the body partly cut away to permit of the insertion and tightening of the square-headed screws.

If the spindle nose is exceptionally large in proportion to the chuck, the plan seen in Fig. 10 may have to be followed, where the screws pass through from inside the bore. With certain types of chucks it is possible to insert the screws from inside the hinder plate of the chuck itself, the threaded hole being then in the adapter; or studs can be screwed into the latter and pass through the chuck plate to receive nuts. In such cases it will be necessary to partly dismantle the chuck, in order to get at the hinder plate.

A different kind of adapter is required for attaching a small chuck to a large flange-nosed spindle, Fig. 11, the screws for tapping into the chuck passing through from the inside of the plate. In fitting special chucks for many tur-

tion of motion of a chuck, it often happens that, in special lathes for repetition operations, reversal is frequent, and then a locking arrangement must be incorporated to prevent loosening. In order to do this, front of the chuck may be recessed sufficiently to permit of a thin locking-nut to be screwed on

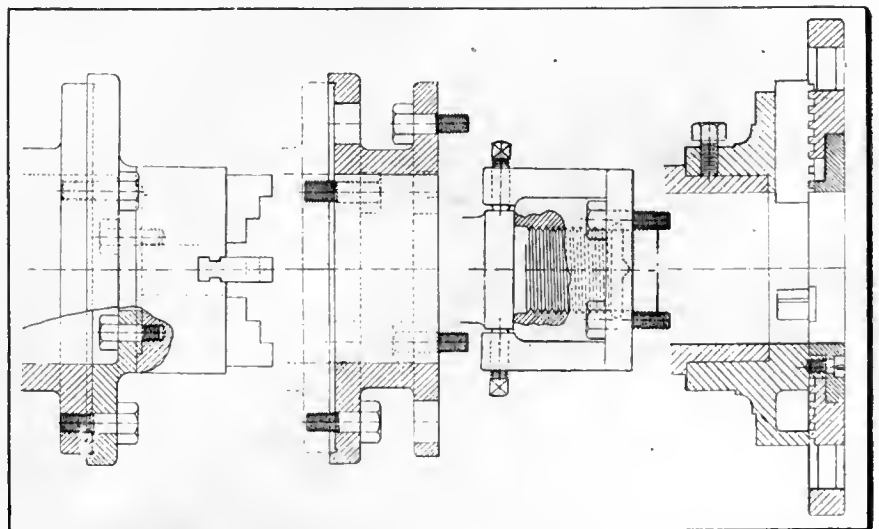

FIG. 11. FIG. 12. FIG. 13. FIG. 14.
TYPICAL METHODS OF ATTACHING CHUCKS TO LATHE SPINDLES.

*From "Page's Weekly."

CAST-ROLL CHILLING PROCESS.

ONE of the difficulties in casting rolls is the liability to internal strain set up by the different rates of cooling in the roll body and neck, with the failure which frequently results from this cause. The method in use by a Foundry Company of Avonmore, U.S., produces, it is claimed, rolls free from this defect. The chief feature of the process is an air blast, which rapidly cools the roll after casting and at the same time permits slower cooling of the charcoal-iron mixture.

The construction of the mould is important. A blast pipe with gate valve is connected to the chilling section of the mould. The rate of cooling and consequently the chilling can be regulated by the gate valve. The chilling section is designed to allow rapid radiation and easy elimination of casting strains in the roll proper. The outer section of the mould has a circular inlet for the blast connection, and it is arranged that the air must pass through spiral grooves before it reaches the rectangular egress opening. When the mould is in position, an air space thus exists between the outer and inner walls: along this the blast is forced. A thermometer at the air exhaust opening indicates the temperature of the escaping blast. The rolls by this method receive a uniform chill, and the surface given practically the same as that obtained by the water chill process, while internal stresses are avoided. The rate of cooling can be varied, so that the necessary degree of polish may be given to the face while the body of the roll cools much more slowly.

OPENING OF C. P. R. SHOPS AT OGDEN, ALTA.

THE C. P. R. has opened its new shops at Ogden, near Calgary, which are the largest railway repair shops in the world. There was no blowing of trumpets for the occasion, and even many prominent officials at Calgary were unaware of the official opening, so quietly and unostentatiously was the ceremony carried out. The opening of these shops, which are called after one of the company's most popular officials, marks a new era in the annals of Calgary and district, if not the Canadian West, for, where less than twelve months ago was open prairie land, today there exists a great hive of industry.

The shops, which occupy an area of 120 acres, are of the most modern construction, and contain the latest appliances used in the construction or the repair of a locomotive that the mechanical world has devised. They consist of a group of twenty buildings, the locomotive works being by far the largest,

occupying a space of 8 acres. Eleven and a half months from the turning of the first sod for the construction of the works, the C. P. R. turned out its first engine.

Employ 2,500 Men.

Between five and six hundred men are now employed in the shops, but it will be about four months before everything is in full working order, at which time it is expected that fully 2,500 men will be found fully employed. The contract for the shop was let to the Westinghouse, Church Kerr Co., and Mr. T. N. Gilmore, railway equipment engineer for the contractors, supervised the work. The power plant is one of the biggest in the West, containing as it does 6 Babcock & Wilcox boilers, capable of developing 2,100 h.p. The concrete smoke stack, 250 feet high, providing a draught for the boilers, is a landmark that can be seen at a distance of many miles. The capacity of the locomotive shops, which will be used for the present to do heavy work on the engines, is between six and eight hundred locomotives a year. The shops will be a great acquisition in the West, and will materially assist the company in keeping its huge rolling stock in the highest state of efficiency.

HYDRO-ELECTRIC CONTRACTS.

WITHIN one month work will be started upon the extension of the Hydro Electric transmission line from St. Thomas to Windsor. The Hydro Electric Commission have awarded contracts amounting to approximately three-quarters of a million dollars for high tension lines and equipment, and the first of this material, the footings, will be delivered in four weeks, according to the expectations of Hon. Adam Beck.

A striking fact in connection with the awarding of the tenders is the fact that Canadian firms won out against foreign competitors in every case. The Canadian Bridge Co., of Walkerville, which supplied the towers for the Niagara line, has been awarded the contract for towers and footings. The Canadian Porcelain Co. will supply all the insulators, this being the first time they have been manufactured in Canada. Galt Malleable Iron Co. has been given the contract for the malleable iron clamps, the Canadian Westinghouse Co., of Hamilton, the contract for the electrical equipment, and W. H. Dunne, of Toronto, the contract for the pressed steel clamps.

Work will be started at four or five points along the line between St. Thomas, Chatham and Windsor, and Hon. Mr. Beck hopes to be in a position to supply Chatham and Windsor with power in a year.

THE ART OF CHOOSING MEN.

A WRITER in the "South African Railway Magazine" describes the manner in which a successful factory superintendent of his acquaintance selected his men.

The General Observation.

Applicants were lined up in front of the office and the superintendent, as he approached the door, glanced from face to face. Then he entered his office, but soon reappeared. Facing the first man, he paused for a moment—his sharp eyes rested first on the man's shoes, then on his knees, his waist-line, collar, chin, mouth, eyes, and hat.

A man, he explained in later years, who has runover heels, seldom does good work; he is generally slipshod and slovenly. The position of a man's knees tells whether he stands up to his work. The waist-line is an index to a man's eating and drinking habits, and to his energy. The set of his collar betrays his sense of neatness—a fine workman is rarely a sloppy dresser. The chin tells more of a man's character than any other physical feature. The mouth and eyes are considered for the same reason. The hat is almost as good an indicator of inherent neatness as a collar, and the angle at which it is worn reveals more of a weaver's character than he would suppose. These signs are not unfailing, but for a quick sorting of men I've found the system efficient and satisfactory.

Value of the Handshake.

Following this scrutiny, the superintendent would step forward and shake hands with the men who scored well under this system. This was to get the feel of their hands. If the palms were dry he felt reasonably sure that the man was of temperate habits and in good physical condition. Again, this gave him a chance to judge of the shape and the hang of the hand. A thorough and experienced machinist generally has a hand of the square, blocky type, and carries it hook fashion.

After the picked men were invited into the office, the superintendent busied himself momentarily with papers. If one of the waiting men crooked his arm over the back of his chair or leaned on the desk he was dismissed, for the man who is used to standing up squarely to his work will not lop or lean—especially when he is applying for a job.

The scarcity of good men would doubtless render many of these character studies superfluous, but they are none the less interesting, as representing a phase of practical experience in the art of choosing men.

The Illumination of Factories and Engineering Workshops

By Hadyn Harrison

It may be said that if the product of a factory is to stand the test of the light of day, there must, of necessity, be available in its manufacture an equivalent light by which the skill and intelligence of the operator and the accuracy of the machine are given full and free scope. This article deals with the electric light feature.

THE illumination of factories and workshops by electric light having become common practice, it might be that there is little more to be said on the subject, but the science of illumination has advanced so materially during the last few years that to those who have studied it and who are in the habit of passing their time in engineering workshops, the systems of lighting they see adopted will often strike them as an abuse of a form of illuminant which, when correctly used, is ideal for the purpose.

It must be borne in mind that the work carried out in engineering workshops is of an accurate nature, which means that not only every detail of the work should be clearly visible to the worker, but also that defects in lighting which must cause a strain on the nervous system should be carefully removed. Under these circumstances glaring lamps must be avoided.

Illuminating engineers have designed, and are now generally adopting, types of reflectors which prevent the actual lamp filament being visible under working conditions. Moreover, these reflectors or shades so increase the candle power or useful rays in the required direction, that the cost of electric lighting is reduced to such a figure as to make it doubtful whether any other form of illuminant can complete.

The cost of electrical energy naturally affects the question, but as mechanical power is often secured through motors supplied by electrical supply authorities, who supply at a very low rate, power combined with lighting, or from a works generating plant, which would naturally be maintained at high degree of efficiency, the actual cost of the electrical energy is generally small compared to electricity utilized for purposes where lighting only is required.

The advantages of electrical driving do not form part of this paper, but it would be as well to mention that in machine shops containing a large number of power-driven tools, the advantages of individual drive affect the illuminating problem as, the counter-shafting and belts being largely dispensed with, the sources of light can be more correctly spaced.

The Daylight Feature.

Before dealing with the artificial illumination of any interior, it is wise to investigate daylight conditions as

these considerably affect the requirements of the workers. For example, a series of recent tests shows that the artificial illumination of some automatic screw cutting machines varied between 9 and 17 ft.-candles, whereas the daylight illumination on the same machines was only 3 ft.-candles. In another case, the daylight illumination was 37 ft.-candles, the artificial illumination being 133 ft.-candles. This tends to prove that the workers prefer a higher degree of illumination than is sometimes obtained during the daytime, and those who have noticed how often a workman will employ an electric hand lamp during the daytime will, no doubt, have come to the same conclusion.

The Albedo factor of machine shop work must necessarily be very low, especially where iron is being worked; therefore, we may take it that the degree of illumination must be comparatively high. The Albedo factor can generally be conveniently measured, but in the case of machine shops it varies every moment, for instance, between rough iron and bright iron, but in no case is it likely to exceed 33.3 per cent. and is very often lower than 10 per cent.; therefore, for exact work, the illumination must be three to ten times more than would be necessary for reading or writing. In the United States, where this subject has received very special attention, probably on account of the high price paid for labor, which has resulted in every effort being employed to increase the output per man, the following values are considered essential in machine-shop working.

	Foot-Candles.
General Illumination, where additional or special lighting of each bench or machine is provided	1.5
Bench Illumination	4
Machines for machine shops with no local illumination..	6.7
Foundries, general illumination	3
Power houses, general illumination	2.5

The Glare Feature.

The above figures may be taken as a very good guide, and no doubt the point which will interest engineers most is how to obtain such results without depreciating the value of the illumination

obtained by introduction of glare or other defects, and at the same time keeping the cost within reasonable limits. With reference to the question of glare, it has been said that a system of illumination may be described as "glaring" when it exceeds any of the limits specified in the following, namely:—

(a)—If the ratio of intrinsic brilliancy of the source of light to that of the illuminated surroundings exceed a certain limit; this ratio should not exceed a value of, about 100.

(b)—If the absolute intrinsic brilliancy of a source exceeds a certain value. The brilliancy of the open candle flame (about 2.5 candles per sq. in.) might be taken as a safe limit.

(c)—If the angle between the direction of vision of the eye when applied to the work it is called upon to do (when gazing at a desk, blackboard, or diagram on the wall, etc.), and the line of the eye to the source of light is too small, this minimum angle may be provisionally assumed as 30 degrees.

(d)—When the extent (apparent area) of the illuminating body is too large, the source should not subtend an angle of more than 5 degrees at the eye.

From these it will be seen that the important points to be taken into consideration are mainly:—

- (1)—The position of the light unit.
- (2)—Efficient shading.

The importance of the foregoing recommendations cannot be overestimated, as they settle once for all the postulate that none of the modern types of illuminants—such as gas mantles, incandescent electric lamps, or arc lamps—can be used unshaded, and further, that many of the modern translucent shades are not sufficiently dense to come within the limits prescribed. On the other hand, where high candle power light units, such as high pressure gas lamps or electric arc lamps are adopted, the density of translucent globes necessary to reduce the intrinsic brilliancy to 2.5 candle-power per sq. in., would so materially reduce their efficiency as to rule such units out of order, unless a semi-indirect system of lighting was adopted.

Reflected Light.

It is becoming a tendency of modern practice to adopt a system by which none of the light sources are visible, or in any case only those which being intended for general lighting (ample local lighting having been separately

arranged for) may be comparatively low in intrinsic brilliancy.

The example suggested is that of a workshop having two bays, one 250 ft. long, 50 ft. wide and 30 ft. high, given up to heavy machinery, the other 250 ft. long, 30 ft. wide and 15 ft. high, devoted to small machinery. There are certain conditions relating to traveling cranes in the large bay and belting in the small bay, which might affect the disposition of the lamps, but as the actual position of these is not defined, they can only be taken into consideration on general lines. The writer in this case has taken for granted that the specified minimum illumination, namely, 1.5-ft. candles applies to horizontal illumination on the floor in the case of the heavy machinery bay, and on the benches or tool beds in the case of the small machinery bay.

Illumination of Large Bay.

The large bay being lofty, namely 30 ft., there are few objections to the use of high candle power units suspended as high as possible, so as to be well out of the line of sight of the workers, as it is obvious that the intrinsic brilliancy of such units will be higher than the regulations relating to glare would permit.

In this case, as all the light is to be directed into the lower hemisphere, no better lamp could be adopted than one of the modern types of flame arc lamps. The width of the building being 50 ft., it naturally follows that if a line of lamps is placed down the centre of the roof near the apex they should be spaced at a distance of 50 ft.; thus, each covers an area of 2,500 sq. ft., the total area being 12,500 sq. ft. Five lamps would be ample, and these could be conveniently run in series on any circuit between 200 and 240 volts, which pressure is now becoming usual in works.

To ascertain the candle power of the lamps necessary to produce a minimum of 1.5 ft. candles on the horizontal plane, it is only necessary to take the maximum distance of the sources of light from the likely point of minimum illumination which would be near the edge of the building, half way between two lamps (provided there is no light reflected from the walls); this distance is 46.4 ft., then the simplest method is to multiply the illumination by this distance cubed, and divide it by the height of the light source to allow for the angle of incidence, the result being divided by two, as the illumination is produced mainly by two lamps. The effect from those beyond them need hardly be included in the calculation. This calculation works out as follows:—

$$1.5 \times 46.4^3 \div 2 = 2,437 \text{ candle power.}$$

Thus, if the lamps produce, say, 2,500 candle-power at angles from 40 degrees downwards, the necessary illumination will result.

Actual practice has proved that a five-hundred watt flame arc lamp can be relied upon to do this; thus five such lamps, taking a total of 2,500 watts, will be sufficient.

Operating Cost of Lamps.

The cost of running such lamps depends mainly on three factors:—

- (a)—Cost of electrical energy.
- (b)—Cost of carbons and trimming.
- (c)—Interest and sinking fund and repairs.

For the purpose of comparison, the cost of electrical energy is taken at 2 cents per unit, this figure being chosen for reasons stated later. The cost of carbons and trimming for this class of lamp is generally found to work out at 6 cents per lamp hour. Interest sinking fund and repairs are taken as 15 per cent. on the capital outlay, which, in this example, would be easily covered by \$250 for the large bay. On this basis the cost works out as follows for 1,000 hours of lighting:—

(a)—2,500 Board of Trade Units at 2c	\$50.00
(b)—Carbons and trimmings at .3d. per lamp hour ..	30.00
(c)—Interest and sinking fund and repairs	36.50
Total for 1,000 hours	116.50
Total cost of lighting bay per hour.	11.5 cents.

Small Machinery Bay.

The small machinery bay cannot be dealt with in the same manner, partially on account of the height being only 15 ft., and more particularly on account of the different class of work carried on there. In this case, the postulate is taken as 1.5 ft.-candles measured on a horizontal plane 3 ft. above floor level which roughly represents level of the benches, lathe beds, and similar machinery.

For this class of work shaded lamps would necessarily be adopted, and the modern illuminating engineer would probably avail himself of one of the opaque patterns of reflector supplied specially for the purpose for use with Tungsten lamps. These are generally designed to produce an even illumination when the light units are spaced a distance apart equal to about twice the height of the lamps above the working plane.

If the lamps and reflectors were placed 13 ft. from the floor level and 10 ft. above the working plane, each lamp would cover an area of 400 sq. ft.; thus, about 20 such fittings would be necessary. As with these fittings the light on the working plane is equal to

double—or even more—the horizontal candle-power of the lamp, one 50-watt lamp in each fitting would give the necessary minimum horizontal illumination; thus this bay would take 1,000 watts or .133 watt per sq. ft.

Working out the costs in the same way as the large bay, we have to consider the cost of lamp renewals which may be taken as 60 cents per fitting per 1,000 hours, interest, sinking fund, and repairs at 10 per cent., which allowing the capital cost as \$145 for fittings and wiring work out as follows:—

Cost of illuminating small bay per 1,000 hours—	
1,000 Board of Trade units at 2c	\$20.00
Lamp renewals	12.00
Interest sinking fund and repairs	15.00
Total per 1,000 hours ..	\$47.00
Cost per hour, 4.7 cents.	

These figures are instructive for several reasons, the most important being the difference in cost between lighting with large and small units. The cost of lighting the large bay with a total candle-power equal to 12,500 or one candle per foot is 2½ times that of lighting the small bay with twenty 45-candle-power lamps, which in the reflectors give 100 candle-power in the desired direction or a total of 2,000 candle-power.

The following figures bring this out more clearly:—

Large Bay—12,500 sq. ft. Floor Area.

Efficiency of lamps in required direction, 5 candle-power per watt.

Total candle-power allowed, 12500.

Candle-power per sq. ft., 1.

Cost per sq. ft. per 1,000 hours .93 cents.

Small Bay—7,500 sq. ft. Floor Area.

Efficiency of light sources 2 candle-power per watt.

Total effective light allowed 2,000 candle-power.

Candle-power per sq. ft., .267

Cost per sq. ft. per 1,000 hours, .62 cents.

The Floor Area Basis.

The writer has always considered that for the purpose of comparison the floor area forms an incorrect basis, for two reasons:—

(1)—The height of the area to be illuminated must be taken into consideration, especially in workshops where large tools are used, which must be illuminated from top to bottom; thus in the case of the large bay making it necessary to illuminate a cubical contents three times larger than that of the small bay.

(2)—The number of workmen employed in a building must necessarily mean a better illumination. This second rea-

son is one that requires careful consideration, bearing in mind the different classes of workshops under review.

In the first part of the paper it was clearly brought out that an illumination lower than 5 ft.-candles would not be adequate, considering the Albedo of the materials. Should this illumination be necessary all over the works, the cost of illumination would be nearly three times as much as the figures given, but to give this higher degree of illumination, where there is nobody to make use of it, is obviously a waste of money—hence the reason why the system of local lighting is being generally adopted. The example of the small bay more closely approximates to the system of local lighting, and the economy is apparent; but let us suppose that 100 men are employed in that bay. It is obvious that it would be more convenient for the men to have 100 sources of light placed in a position to suit each of them. These sources might be made to give 50 effective candle-power over an area, say, of 10 sq. ft., which would then be illuminated up to a degree of 5ft.-candles by placing the light source 3 ft. above it. By this means a working illumination would be provided at nearly the same cost as 1.5 ft.-candles specified, which is barely a working illumination even when the Albedo factor approaches 100 per cent.

Better Basis Suggested.

It appears, therefore, when considering the illumination of machine shops, that the cost of illumination per man would be a better basis to work on, and is, therefore, worthy of careful discussion and consideration. The writer has considered the question from this point of view, and finds that a basis of 10 watts per man for local lighting, plus a small amount for general lighting should prove ample for general work, provided, of course, that suitable efficient opaque reflectors are adopted.

When going into the question of cost, it will be noted that 2 cents per unit was taken as a basis. It will, no doubt be said by those opposed to electric lighting that this cost is too low, but as most large works have either got their own generating machinery or are supplied by power companies, it will be found that it is a very fair average. Even in smaller works using power, the cost of electric lighting is such as to make its adoption advisable. For example, in a works which came under the writer's notice, the lighting was originally gas, and two gas engines were used for driving the machinery. About 200 Tungsten lamps were installed and supplied with electricity from a dynamo driven off one of the gas-engines. This has now been running for two years, and the proprietor states that the cost

of gas for the gas-engines has not appreciably increased, whereas the consumption of gas for lighting, which was previously a large item, has, of course, ceased.

Local Lighting by Gas.

Local lighting cannot be conveniently carried out by means of gas, as small light units, such as 20 candle-power, are not efficient when using a flame source, and are, moreover, not adapted for use in efficient reflectors, on account of the heat given off and the proximity of the operator to the products of combustion. For reasons such as these, the public bodies naturally utilize and recommend the use of electric light, but it should be unnecessary to cite examples to engineers who have, no doubt, learnt already the effect of gas on the working capacity of their employees. As regards degree of illumination, statistics have been obtained and published showing that defective illumination is often responsible for a decrease in output varying from 12 to 20 per cent.

Efficient illumination can be obtained by the use of electric lamps, correctly spaced and shaded, at a cost which is probably lower than any other type of illuminant. This fact, combined with the valuable hygienic properties associated with electric lighting, has resulted in nearly all large employers of labor adopting this means of artificial illumination. The smaller employers will, no doubt, follow their example when they realize the benefits which would result both to themselves and their employers.

Abstract of a paper read before the Manchester Association of Engineers.



FIRE RISKS IN MACHINE SHOPS.

THE possibility of fire in the average machine shop seems very remote. In the modern shop with extensive bays of but one floor, and with concrete flooring, iron roofs, etc., there seems to be nothing in the structure that can burn. There are, however, a large number of very old shops which must by this time have become well-nigh saturated with oil and grease, and which would, if occasion arose, demonstrate to the full their highly inflammable nature.

One is apt, in looking through a machine shop, where everything of prominence is metal, to disregard the possibilities of an outbreak of fire. In many shops the chance of escape if fire occurred would be very remote, as there is hardly walking distance between the tools; in fact, it would be an absolute impossibility to walk in a straight line even half-way across or along the shop. It behoves employers, therefore, to provide a ready supply of chemical extinguishers and like means for dealing with any possible emergency in this direction.

A SUCCESSFUL PROFIT-SHARING SYSTEM.

MR. CHARLES W. ELLIOT, President Emeritus of Harvard, was the guest of honor at the annual banquet of the employees of the Simplex Wire and Cable Co., Boston, and, in the course of an address on profit-sharing, said that he considered the plan originated by the Simplex Company to be one of the best he had yet seen. He said that some plan of profit-sharing is the most effective method he has found for furnishing a motive of especial interest to employees, for, in spite of the fact that wages have steadily advanced and the hours of labor have decreased, happiness and contentment of labor has not followed. There must needs be some additional motive back of all labor which will give a man an incentive to work, something in which he is vitally interested. He wants to look forward to something besides his regular daily wages—in a word, he wants a share in the profits he has helped to produce.

The profit-sharing system adopted by the Simplex Company has several interesting features. On the first day of each year a list of the names of those employees of the company who have been in continuous service for the previous twelve months is prepared. The men on this list are entitled to share in the profits of the company if they are still in its employ on the 1st of March. The directors determine the percentage of the net profits that shall be appropriated to the profit-sharing system for each year. Extreme publicity of the affairs of the company is avoided, and the company protects itself by a rule that it will not pay to one man over 20 per cent. of his earnings. A table of dividends paid shows that these have been as high as 18 per cent. of the men's earnings in 1906 and 1907 and as low as 9 per cent. in 1910. Thus the size of the dividend depends on the success of the year's business.

The system has been given a thorough try-out. The share of each worker is in proportion to his pay. The men become interested in the results of their own labor as well as watchful in preventing the mistakes of other fellow-laborers. Each one has an incentive to do his best work. As a result the business of the company has regularly increased and satisfactory profits have been made.

Dr. Elliot said that he believed that it is essential for the officials of any company to gain the confidence of their men before any such plan can be completely successful.

The Question of System and Costs in the Repair Shop*

By Richard Thirsk

The author of this paper shows what can be done in many of our large general manufacturing establishments equipped with their own machine shop, towards the provision of repair parts and renewals, by the adoption of systematic production methods, cost records and supplies regulation. The subject is one for wide and profitable application.

MANUFACTURING methods in the mill repair shop are something of a novelty. But if satisfactory arrangements are made and carried out it is my belief that most repair shops of fair size will find it a profitable investment. Of course, it calls for a somewhat larger investment in tools than is usually found in repair shops, but that is a minor consideration compared with the benefits to be derived. There are many jobs that must be handled in the usual repair shop style, but there are also many jobs that may be profitably handled under manufacturing methods, and will show a large margin of profit over the old system. As a rule, all repair parts, especially for looms, may be made up in sufficient quantities to justify the expense of making jigs, thus insuring interchangeability and low cost of manufacture.

Typical Example.

Take, for example, a job handled a short time ago. An order came into the shop for 90 draft gears of 40 teeth 24 pitch, 2½ inches outside diameter, ⅞ inches face, and having a 21-32-inch taper hole. The blanks were chucked in a universal chuck on a 16-inch turret lathe. The first operation was to drill the 21-32-inch hole; the next to face off one side, which was done with a tool in the cross slide. The hole was then reamed with a taper reamer, a collar on the latter determining the diameter of the hole. The blanks were next key-seated, a 5-32-inch hole being drilled through the blank and drifted out with a square tool. A hardened steel plug with a key was used to finish the blanks, these being pushed on to the plug, and two cuts taken over the face with roughing and finishing tools held in the turret, thus sizing the blanks without calipering. A cut was next taken across the unfinished side, making the width ⅞ inch and completing the blank ready for cutting teeth. The teeth were cut on a Whiten hand-feed gear cutter, the machine being operated by a boy at 75 cents per day. The 90 gears were completed in 9 hours actual time, including setting the tools, and the cost figures as follows:

Nine hours for a man at 20 cents, \$1.80; 9 hours for boy at 7½ cents, 68

cents. The blanks weighing 88 pounds, at 3½ cents a pound, cost \$3.08, making a total of \$5.56 for the 90 gears. The usual manufacturer's cost of these gears is 48 cents each, making a total of \$43.20. Deducting the cost of the blanks, \$5.56, there is thus a saving of \$37.64 on this particular job. If these gears had been made by the usual method, drilling the hole and reaming by hand, driving them on a mandrel and finishing in an engine lathe, calipering to size both diameter and face, it would have taken at least three days, not only showing a greater cost, but also a longer time before they could be put to use.

Repair Parts for Looms.

The writer has for several years been making all repair parts for 800 looms, employing this method, and finds that the cost averages a little over 35 per cent. less than the same parts purchased from the loom makers. The average number of pieces used is 160 per week and the average weekly cost is \$17.19, or .0214 cents per week per loom. When purchasing repair parts from the loom makers, using the same amount of pieces, the average cost per week was \$23.20 per week, or a difference of \$6 per week. All parts are made in quantities just as they would be if made for sale. They are placed in stock and given out as required, and charged against the section using them, a weekly report being made up showing the number of parts used on each section and cost of same. One copy goes on file in the office and another copy is given to the overseer, enabling him to get a line on his repair cost, and incidentally showing him who is the most efficient section hand.

Anticipation of Requirements.

It should be the aim of the up-to-date mechanic to anticipate the needs of the mill and as far as possible keep repair parts on hand for all emergencies. I am aware that in a mill of fair size it would preclude the fact of the master mechanic working, as is the custom in some places, but, given the right type of man, more can be accomplished by his keeping the hands at work than by doing manual labor himself. The old saying exemplifies this: "The eye of the master can do more than both of his hands."

I can look back some fourteen years, when I arrived at a mill, which had been running some six months, to take the place of master mechanic. I found a very well fitted up machine shop, with good modern tools, some of which had never been belted up. There was one man and a boy in the shop, the former being engaged turning some let-off studs for looms. He was making them in the old-fashioned way, cutting off each piece to length, centring and turning them in an engine lathe, calipering each diameter and measuring each length. He said, proudly, that he was making ten each day. Among the machines was a pretty fair 16-inch turret lathe, neither belted up nor equipped with tools. After getting this lathe fitted up, the stud job was put on, 70 to 75 of these studs were made in a day by the same workman who had been making ten per day, thereby reducing the labor cost from 20 cents to .028 cents each. As there were about 1,200 of these studs used yearly, this one item alone showed a saving of over \$206.

Qualifications of Master Mechanic.

Now, a few words in reference to the qualifications of the master mechanic in a modern mill. In the first place, he should be a thoroughly practical mechanic, able to perform any job that comes to the shop and to do so quickly and well. He should not necessarily have to do so, but to enable him to see that his men were using the best methods and to correct them if found doing otherwise, this personal skill is of the utmost importance. I have come across some cases where the master mechanic was a mere figurehead, and had to rely wholly upon the skill and judgment of his subordinates. Happily, this class of men is rapidly becoming obsolete.

He should be well versed in steam engineering, both practice and theory, and, in addition, be thoroughly conversant with electricity, so that, no matter what power is used, his general knowledge will be equal to the occasion. All shafting, main belts and other apparatus should be periodically inspected to guard as far as possible against a shunt down during working hours. Of course, there will be accidents and stoppages that every precaution will not eliminate, still a great many may be avoided by a

*From a paper read before the Southern Textile Association.

good system of inspection. As a matter of fact, he should aim to be a preventer of repairs rather than a repair maker.

The Question of Supplies.

Just a few words on the question of supplies. In a small mill this may very well be handled by the superintendent, but in the larger mills supplies should be under the jurisdiction of the master mechanic. The writer has handled the purchase and distribution of supplies for the past eight years, and practises the following system:

A supply room, 32 x 48 feet, is fitted up over the machine shop, and is in charge of a competent man, on duty all day. The card index system is used, there being a card for every article used. On this card is entered the date of receipt of goods, together with invoice, price and cost per piece. On the same card is entered from time to time

the amount given out, the party or department charged, and the cost of same. These cards are footed up every month, and a monthly statement made out for the office showing supplies received, amount given out and to whom, and cost of same. The supplies on hand are carried forward to another card to be used during the following month. It is thus a very simple matter to ascertain in a few minutes just what supplies are on hand, how much has been used, and the cost at any time. Our supply room inventories about \$5,000, and contains almost everything necessary in a textile plant.

Under the system, or rather lack of system, in vogue previously, each overseer had a supply room and ordered his own equipment, with the result in many cases that there was an excess of stock carried in the aggregate.

considered why this is so? Much the same form of sports, now so popular, existed thirty or forty years ago, yet they could claim not one-tenth the adherents. With the introduction of the workers' half-holiday, however, and a lessening of the daily responsibilities attached to their occupation came the desire for some form of tonic which would act upon their lethargic minds and awaken the mental torpor into which they allow themselves to be plunged during working hours. Now, I would be the last one to deprecate a natural inclination for some form of healthy sport, providing it does not crowd out everything else. When the result of a football match becomes a matter of more importance than, say, the fit of a crank pin, then it is time to put in that man's back hours.

Sport for Variety.

The writer once had working for him a most capable and reliable fitter, who suddenly developed an abnormal interest in football. One of his qualifications which made him valuable as a mechanic was that he possessed a remarkably clear memory for detail. Moreover, he was conscientious, painstaking, and in every respect an acquisition to any shop. One season's interest in football, however, wrought a remarkable change in him. When asked such and such a question relating to some past experience connected with his business it was found that his memory was at fault; yet he could reel off without a single error the number of goals recorded for and against his favorite club during the past season. The climax came when a breakdown demanded his attention one Saturday afternoon. He asked for the time off to witness a match, but he was refused; then, flinging prudence to the four winds, he did what he would never before have dreamed of doing—took French leave. He lost his job through it.

Here is another illustration which goes to prove that brainless occupation engenders an unnatural inclination for sport, and that when the former conditions are reversed the craving for the latter ceases. A young fellow who had served his time partly at the bench and partly at the lathe, quick, clever, and of an inventive mind, found himself, through the exigencies of the shop, compelled to temporarily take in hand the operation of a large lathe, his principal duties being the facing of large steel discs used for disintegrators. This class of work demands little attention beyond setting and occasional tool changing. Up to this time he had been in the habit of regularly attending night classes at a technical college, and otherwise had shown an intense desire to get out of the rut. At the beginning of

The Decadence of the Machinist and Fitter

By Frank R. Parsons

As one to whom scores of applications for employment are made during the course of a year, the writer is in a position to speak with some authority on the subject of men and their qualifications. His position as a departmental manager would also show him to be a fairly reliable judge of machine tool operators and workmen generally.

IT SHOULD be clearly understood at the outset of this Article that the writer has no particular axe to grind in following the course he is pursuing; neither would he, without sufficient cause, be one to decry a class of men with whom he has rubbed shoulders since leaving school, but he feels persuaded that the time has come when the question of the decadence of the machinist and fitter should be analysed and the truth told without mincing of words. If the result of this article be such as will make one single individual think sufficiently to talk the matter over with a brother craftsman, and so in turn set him thinking, then the writer's purpose will have been served, if only to a limited extent.

Brain Activity Unnecessary.

Chambers' "Twentieth Century Dictionary" defines the meaning of the word "decadence" as "a state of decay, not distinguished for vigour or originality," and I am now going to assert that this is the condition into which the trade indicated is fast sinking, and, unless a halt is soon called, its prestige will be lost to us for ever. I am not going so far as to say that upon the individual rests the whole responsibility for this decadence, large as his share might be. Evolution of machinery, machine-controlled methods, specialisation,

and piece-work have all contributed their share towards this end, but this is inevitable. It would be equally as futile to attempt to sweep back the incoming tide as to arrest mechanical progress. What I mean is that the workers referred to have allowed themselves to become driftwood, by losing their professional pride. With the lessening of responsibility, due to the inception of more positive machine-controlled methods, the human agency is not so much a factor of importance, not so much a necessity; with the result that more time and opportunities permit other matters not connected with their daily occupation to creep into their working lives until these in time become supreme.

Repetition Work Monotonous.

Since machinery now solves the intricate problems which hitherto had to be attacked by the human mind, it is inevitable that the latter will wander from the prosaic operation of watching a machine engaged upon repetition work day in and day out to matters more congenial, less monotonous, and in which there is a greater element of variety. To this we undoubtedly owe something to the present state of things into which we have drifted. Everyone will admit that more time, money and energy is devoted to recreations and sport now than ever before, but have you ever

one winter, however, some three or four months after his change of job, these studies abruptly ceased, and on several occasions he was caught by his foreman perusing sporting and football papers during working hours. He was repeatedly reprimanded for gossiping and inattention to his work, and was responsible for the initiation of a weekly sweepstake on football results among his shopmates. Ultimately, the change in him became so pronounced that he got entirely out of hand, and so was discharged.

Through the influence of the writer—who, despite the necessity for so drastic an action, really felt sorry for the lad, and fully realised that, after all, he was but the victim of circumstances—he obtained another berth with an engineer who carried out a deal of small experimental work for inventors. This turned out to be the youth's forte. Because his daily exercise called for the continual exercise of his brain, and the work being congenial, sport was relegated to the back-ground. He resumed his neglected studies, avoided the football field, discontinued filling up sporting and football coupons, and threw his whole soul into his business, with the result that to-day his employer wouldn't part with him for any offer.



APPLICATION OF ELECTRIC MOTORS TO WOODWORKING MACHINES.

By Alexander T. Deinzer.

ELECTRIC drives are taking a prominent place in wood-working plants and are proving satisfactory and highly advantageous over the old methods of drive which utilize long lines of shaftings and numerous idler pulleys and belts.

Investigations of plants operating from line shafting and belt drive show that from 25 to 60 per cent. of the total power, when all machines are working, is taken up in driving the belts and shaftings. This fact, when considered in connection with the fact that the average load in woodworking plants is only 10 to 35 per cent. of the total connected load, shows that the friction losses due to the shafting and belts amount to practically the greater part of the total energy used.

Motor Eliminates Friction Losses.

The electric motor largely eliminates such losses, for when a machine is standing idle, no power at all is transmitted to the motor. Again, when a machine is running light, the motor takes from the line only enough power to overcome the friction losses in the driven machine plus the losses in the motor itself, which are

well known to be comparatively slight. Further, the electrical losses in a well-designed transmission line, are so slight as to be comparatively negligible.

When a machine is in service, practically all the energy is available for performing the operation in hand, and the foregoing points may be summarized in the unquestioned statement that the electric motor drive represents the most efficient method of securing the highest percentage, at the driven tool, of the initial energy developed. The electric drive, by direct economies in those charges debited exclusively to power, and by increasing the product with a given equipment and personnel, reduces the unit cost of the product.

Improved Quality Product.

The quality of the product is generally improved where the electric drive has been substituted for belt drive from jack shafting, for good product from woodworking machinery is dependent upon a drive capable of transmitting even and constant torque to the cutting tool. The electric motor meets the requirements, for it will not quit readily, neither will it slow down appreciably on overloads, but will maintain a practically normal speed even if the power demand greatly exceeds the limit of the rated capacity of the motor.

Characteristics of Wood-working Machinery.

It is characteristic of woodworking plants that the material handled is bulky; that is, a great bulk of material must pass over each machine in the course of a day. Where such conditions obtain, it is urgent that the machines be so arranged in relation to each other that the material be moved only the slightest possible distance in going from one machine to the next. The individual motor drive or combined individual and group drive in woodworking plants makes possible an arrangement of machines which secures the greatest possible output with any given equipment of floor space machines and men.

Systematic Arrangement of Machines.

The economy to be effected, by reduction of losses in transmission of power in woodworking plants which the electric motor secures, will oftentimes merit a change to the motor drive, but the increase in output due to systematic arrangement of machines will generally be of even greater value in reducing unit cost of production and is in fact one of the strongest reasons for the adoption of motor drive in woodworking plants.

Another point of great advantage in favor of the electric motor drive is the ability to move motor-driven machines to other locations in the shop either permanently or temporarily, as for instance,

where the line of production is changed, or where some large contract involving special operations is in hand. Individually motor-driven machines lend themselves admirably to such change of location, for they are not dependent upon an installed line of shafting for power, but instead may be supplied with power from temporary wires which may be run practically anywhere with but slight labor and cost. In fact, motor-driven machines can be installed in places wholly inaccessible to a line shaft.

Plant Extension Feature.

Where extensions to the plant are contemplated the motor drive is advantageous, for the location and arrangement of the new part of the plant is independent of the power layout of the original plant. In this connection it might be explained that where mechanical transmission of power from one building to another is used, it necessitates the buildings being placed either parallel or end to end, for the bevel gear or angle belt turn necessary to transmit power from one building to another located at an angle to it, are not practical.

Miscellaneous Advantages.

Danger to operatives is reduced by the elimination of shafts and belts.

Reduction of fire risk, and often remarkable lowering of insurance rates is due to possibility of having the power house located at a distance from the shops, in the ease of motor drives.

Better light on work secured, is due to elimination of shafts and belts.

Economical operation of individual machines or plant sections is effected when rush orders may demand overtime work in parts of the plant.

Motor Types.

Both alternating-current and direct-current motors are used in driving woodworking machines. The direct-current motor has advantages where wide speed adjustment is demanded. Exceptional conditions, therefore, may warrant the use of the direct-current motor for driving woodworking machines; however, under the usual conditions, the induction motor is the better adapted.

Advantages of the induction motor are: Occasional filling of oil wells with occasional inspection of oil rings to see that they operate properly is the only attention required; operate inherently at practically constant speed independent of ordinary voltage fluctuations or load, within limit of output; are light in weight and small in bulk for given output; possess remarkable ability to withstand violent peak loads; having no brush rigging or moving contacts, the squirrel-cage multiphase induction motor is immune to fire risk.

MACHINE SHOP METHODS ^A_N^D DEVICES

Unique Ways of Doing Things in the Machine Shop. Readers' Opinions Concerning Shop Practice. Data for Machinists. Contributions paid for.

HOME-MADE FIXTURE FOR DRILLING CYLINDERS.

By Olaf Melby.

SOME time ago we had quite a number of large cast iron cylinders to make. The heads, fastened by $3\frac{3}{4}$ -inch cap screws, were easily drilled on a drill press, but we met trouble when it came to the cylinders. As this work was somewhat out of our line, and not feeling inclined to buy any new and expensive machinery, we had to get the work done the best way possible. The accompanying sketch illustrates the very simple fixture made. (A) shows the cylinder to be drilled and (B) the head, which served us as a jig after two holes were ratcheted and tapped in the cylinder.

The fixture is fastened on the centre of the cylinder head, and the drill (C) can easily be swung around the whole periphery of the cylinder. (D) represents fast and loose pulleys, which, together with gear (E) are mounted on shaft (F). This shaft has an enlargement on the inside, and is made to fit the centre of the journal, assuring that the holes are drilled perfectly straight. Shaft (G) is driven through gears (E1), (E2), (E3), and forms the socket for holding drill (C). The spindle (G) is partly covered with a bushing (H), which can be moved longitudinally by hand wheel (J), but is prevented from turning by set screw (K) fitting in slot (L). (M) and (N) form two oil chambers, which were kept full of oil all the time.

This fixture was made very cheaply, as we used gears from a lathe and took

the pulleys from a pump we had on hand.

Two handy men could drill one end of the cylinder, or $30\frac{5}{8}$ -inch holes, in one hour and fifteen minutes.

DRAWING SHELLS.

By X. Y. Z.

IN drawing shells, as in Figs. 1 and 2, it is sometimes necessary to make several drawings to get the desired depth and diameter of shell, without splitting the stock. The first operation is done in an ordinary combination blanking and drawing die, from which we get a shell like Fig. 1. For the second operation, I have found a push-through die, as shown in Figs. 3 and 4, much quicker than the ordinary re-drawing die, and less expensive to make. This die of course can only be used where the sides of the shell are comparatively straight.

(A) is a section die shoe, and (B) a cast steel die, which if made of high speed steel, will last much longer. This die is bored out to the diameter of the outside of the finished shell Fig. 2, then counter-bored part way through to fit the outside diameter of the shell as it comes from the first operation Fig. 1. The counter-bore is used to locate the shell central, and should be deep enough to hold it in a perpendicular position, so that the punch (C) will hit it fair. The bottom of the counter-bore should be beveled off to about 45 degrees to prevent cutting of the shell, while the edge of the bore should be left sharp. The punch (C) is of cast

steel, turned to the inside diameter and shape of the finished shell, the other end fitting the ram of the press. The working end of the punch and also the die should be as hard as possible. When

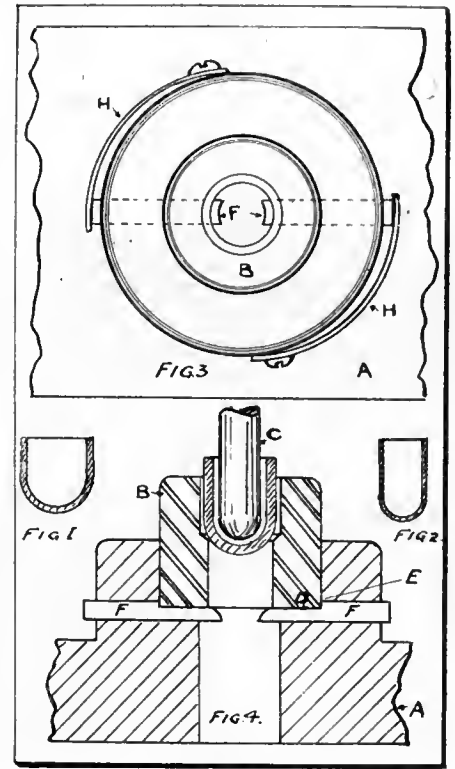

DRAWING SHELLS.

the die is set up in the press, a shell is placed in the counter-bore and, as the punch descends, it pushes the shell through the die, making a shell of the smaller diameter and longer. When the punch returns, the shell is stripped-off by the sharp edge on the bottom of the die.

I have found in practice that the shell will sometimes stick to the punch and come back through the die. To obviate this I have found two spring pins (FF) very serviceable. Two holes are drilled, one from each side of the boss, on the cast iron shoe. These holes should be marked off so that the drill will break through and make a half round groove in the die seat, of a depth of about 2-3 times the diameter of the drill. The pins are milled flat on the top side (D), to allow the die to rest on its seat. This keeps the pins from turning around, and the shoulder (E) acts as a stop for them against the outside of the die; the shoulder (E) also keeps the pins from projecting too far into the hole. The inside end of the pins are filed out to fit

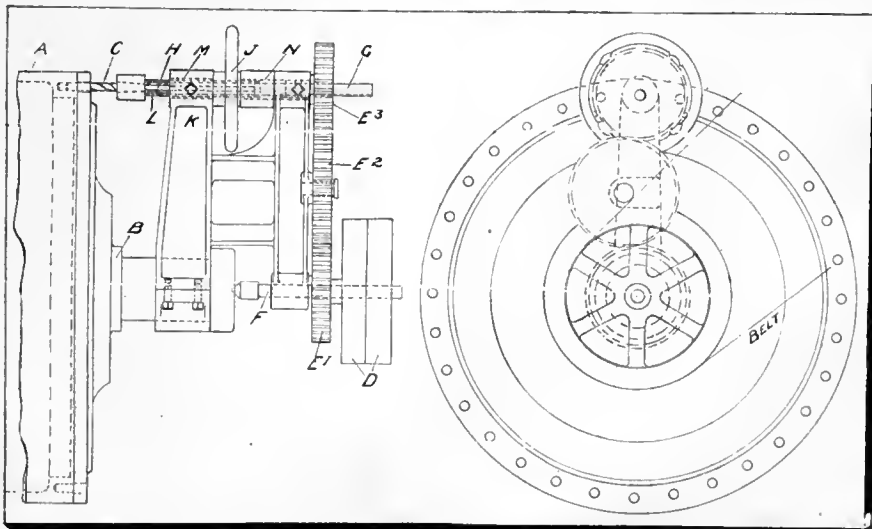

HOME-MADE FIXTURE FOR DRILLING CYLINDERS.

the diameter of the punch, the upper corners being beveled off so that when the punch descends, it will push the pins outward against the springs (HH), and when the punch returns the pins hug the punch and make sure that the shell is stripped. I have found these pins to work very well, also on small double-action dies, where the shells have a tendency to come up through the latter.



MILLING FIXTURE FOR CRANK CASE.

By R. P.

OF the following illustrations fig. 1 represents one half of a motor cycle crank case, an aluminum casting on which the first operation is milling the edges (X) (X). Fig. 2 shows the fixture for this operation. Here the boss (Y) of Fig. No. 1 fits loosely in the groove (A), while the sides of the crank case rest against the hardened locating plates (B). The work is located lengthwise by the stud (C) which passes through a cored hole (Z) in the work. This stud has a clamping strip (D) which fits the inside of the work and by tightening the nut (E) on the end of the stud, the clamping strip holds the work in position. As the casting is in the rough as held in this fixture, it does not locate firmly and evenly, so adjustable spring plungers (F) are provided which bear against the edges (W) on Fig. No. 1, and thus provide even support for the work.

When removing the finished work, it is not necessary to remove the nut (E), the nut being loosened one turn and the (U) washer (G) providing an easy means of removing the clamping strip.



DRILLING JIG FOR A CRANK CASE.

By L. E. G.

THE accompanying illustrations show a crank ease for a motor cycle and the drilling jig used for drilling part of

the holes. The latter is located in the jig by means of two holes already drilled shown at (A), fig. 1, and rests on two studs (B), Fig. 2, which have projecting

ings (I) are used for drilling the tapped holes (J), fig. 1, around the edges of the work, and bushings (K) are used for the large holes (L). As these vary in

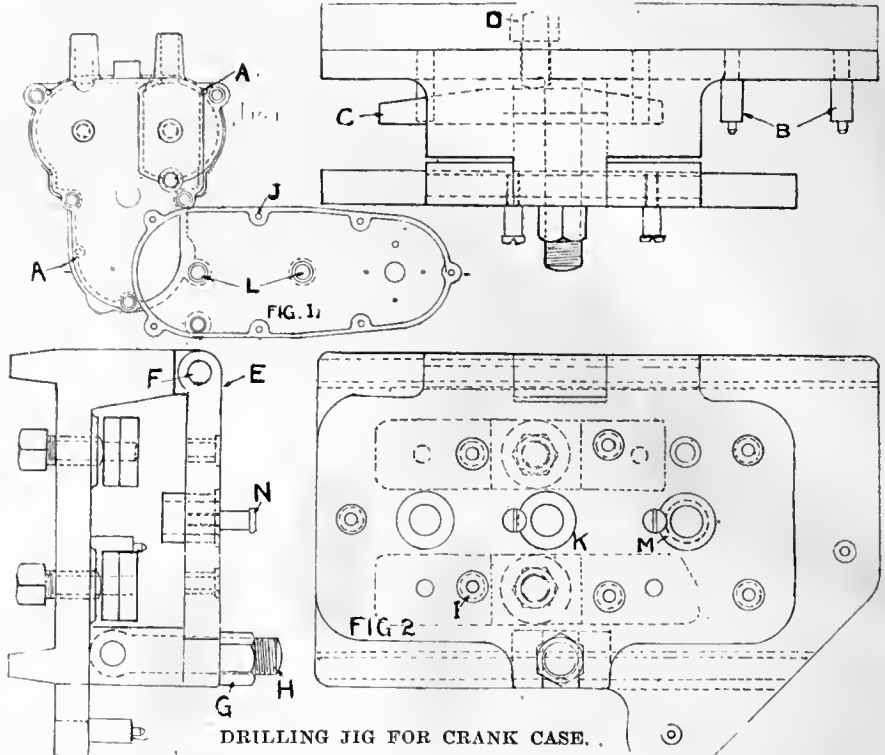

pins fitting these holes. Part of the work is projected from the left hand side of the jig, while the end to be drilled rests on two adjustable rests (C), which

size, in different styles of cases, slip bushings (M) are provided, being placed inside of bushings (K), and held in position by screws (N). The rests (C) are

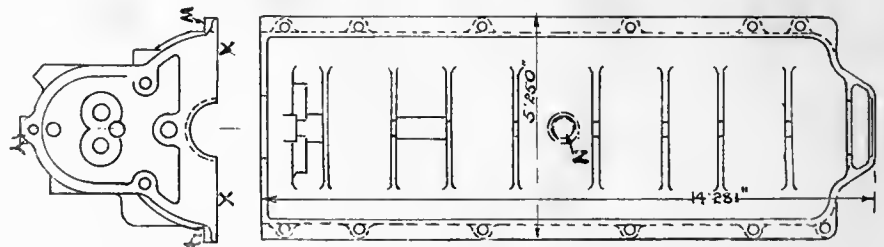

FIG. 1. MILLING FIXTURE FOR CRANK CASE.

are adjusted by means of screws (D). The leaf (E), which swings on the pin (F), and is elamped shut by means of swing bolt (G) and nut (H) is closed and the work tightened against the leaf by the adjusting screws (D). The bush-

made adjustable on account of the variation in the thickness of the work handled.

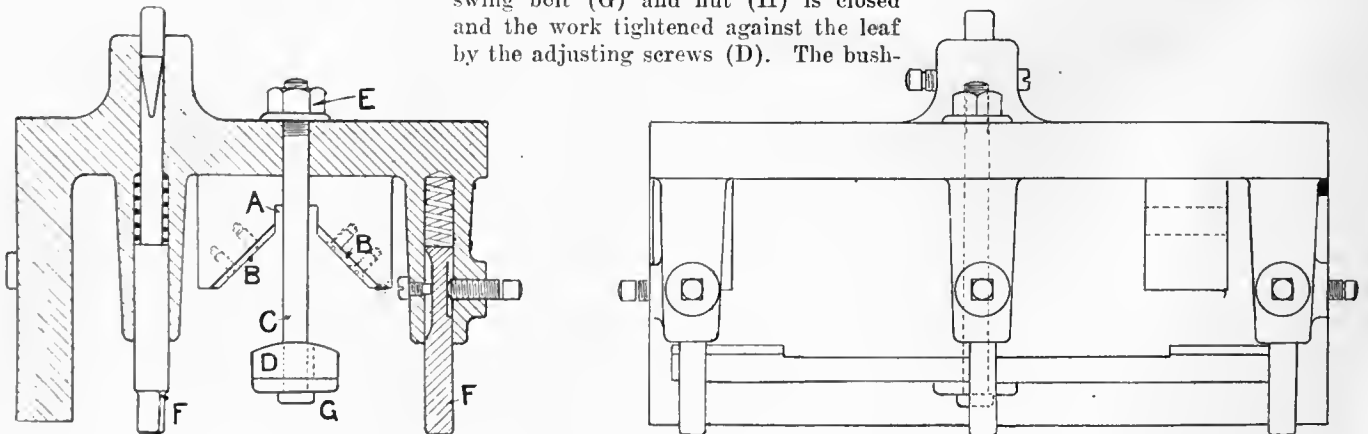

FIG. 2. MILLING FIXTURE FOR CRANK CASE.

INCREASED SCREW MACHINE PRODUCTION.

By H. G. P.

IN a large shop where I was formerly employed we succeeded in making some large reductions in the cost of making screw machine products by increasing the rate of production without any increase of cost. One of the most remarkable instances was the result of a suggestion received from one of the operators, and had to do with the making of a large lot of screws, as shown in the figure from drill rod, which is a very difficult material to thread successfully, especially when working to a thread gauge with a variation allowed of only one-thousandth of an inch in diameter. The sketch shows a screw used as a set screw, being chamfered on the end, and having a cup point. It was necessary to make this from drill rod, on account of the hard service demanded from it.

The screws were formerly made at the very low rate of 250 in ten hours, a circumstance partly due to the unsuitable machine used for the job. The order of operations for the job was as follows:—

- Centre (left hand).
- Thread (with roughing die).
- Thread (with finishing die).
- Feed stock to stop.

At same time, chamfer cut off and form (combination tool).

A high reverse speed was used for all operations except threading, which was done with a forward speed of one-half the reverse. All operations were accomplished successfully except threading with the finishing die, which did not always engage with the threads cut by the roughing die as it should, thus forming in them a rough stripped or tapered thread.

To improve the methods used, one of the operators suggested, instead of the machine in use, to use a small Brown & Sharpe automatic, in which the change

of spindle speed and feed of the tools could be more widely varied. As an improvement in the finishing die it was suggested to make it, as shown in the sketch, by taking an ordinary Brown and Sharpe die holder (B) and inserting a small piece of coiled spring at (C) between the die holder head (A) and body (B). The spring inserted at (C) allowed a flexibility of the part (A) backward against (B), when leading on to the thread cut by the roughing die. This gave surprisingly accurate results.

Not only was the work more satisfactory in quality, but by the use of improved tools it was possible to speed up

drill press. This was made especially for drilling front spring axle pads for automobiles. There were four 1/2-inch holes set at fixed centres, and drilled right through the work, and a blind hole 5/8 inch in the middle. The drill lengths were arranged, so that the smaller size drills get through the work before the centre one starts to drill. It will be seen by this plan that the centre drill is not overworked, which it otherwise would be, if they were all drilling at the same time.

The main driving member (A) is a solid steel forging, out of which is formed the main driving shank (B). The

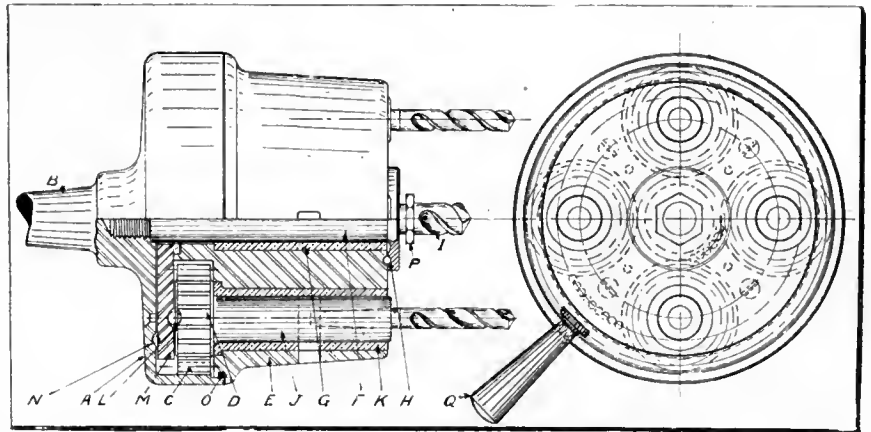

MULTIPLE SPINDLE DRILL ADAPTER.

the machine from a production of 250 screws a day to a production of 1,250, or an increase of 400 per cent. Besides being an excellent example of good results from the suggestion system, the method shown of threading drill rod should be of interest to any who may be able to use it.

MULTIPLE SPINDLE DRILL ADAPTER.

By H. R.

THE drawing shows a five-spindle drilling machine with an ordinary taper driving shank, adaptable for any

internal teeth (C) which form the drive for the pinions (D) are also cut out from the member (A), and are case-hardened. The bottom member (E) is of cast iron machined all over, and is held in place by the centre spindle (F). This spindle runs in a phosphor bronze bush (G) and on the ball race (H) and also forms a driving socket for the centre drill (I). The pinions (D) and spindles (J) are of steel and are forged solid. They have taper holes to suit the small drill shanks, and it will be seen provision has been made for knocking out the drills. The pinion spindles (J) have return spiral grooves cut into them for lubricating purposes and have extra long bearing surfaces running in phosphor bronze bushes (K), which are pressed into the casting (E). The thrust of the small drills is taken up through the balls (L) on to the mild steel plate (M), which is spigotted to the casting (E) and is screwed and dowelled in position. The plate (M) conveys the pressure through to the ball race (N), then to the main spindle. The whole machine runs in oil, and is made absolutely oiltight by the asbestos ring (O). The nut (P) on the centre spindle can be used either to withdraw the drill or to locate the depth of hole to be drilled. The handle (Q) is screwed into the casting (E), and is necessary for steadying the machine on to the work.

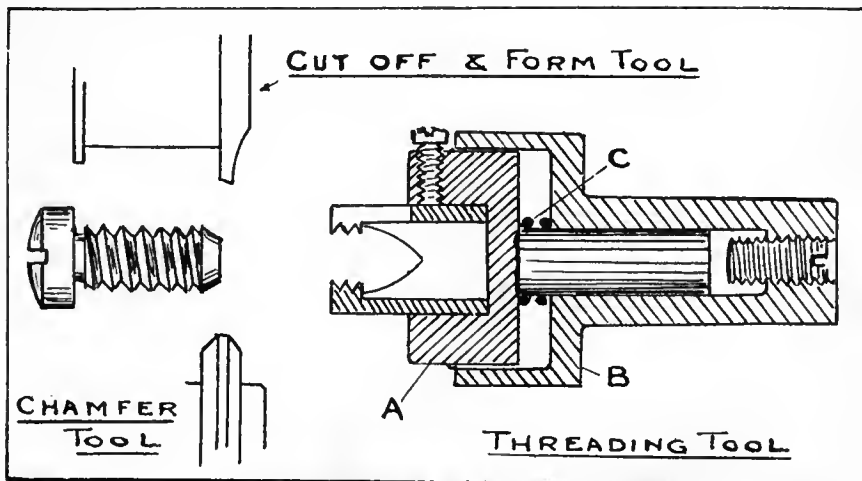

INCREASED SCREW MACHINE PRODUCTION.

DEVELOPMENTS IN MACHINERY

A Record of New and Improved Machinery Tending Towards Higher Quality and Economical Production in the Machine Shop, Blacksmith Shop or Planing Mill.

IMPROVEMENT IN HYDRAULIC PIT JACKS.

THE Watson-Stillman Co., 50 Church St., New York City, have recently made an important change in the construction of its hydraulic pit jacks which has greatly improved these tools. The old-fashioned, hand-operated pumps have been replaced by pumps driven by air engines and these are attachable to



IMPROVEMENT IN HYDRAULIC PIT JACKS.

any style or size of jack manufactured by the company.

The use of compressed air at about 90 pounds per sq. in. pressure has become so universal in round houses and railroad shops that the air-driven engine adapts itself admirably to modern shop equipment. To make the power connection, it is merely necessary to run a rubber hose or other flexible tubing from the shop air main to the pump engine, just as is done in the case of pneumatic riveters. The operating valves can be placed in any convenient position, permitting the foreman or man

in charge to operate the lift in addition to directing the work of his men. The use of this air engine, therefore, eliminates one man—the pump operator—from the crew.

By the use of air power, the speed of operation is very greatly increased. When it is desired to raise the saddle up to the work, air is admitted directly at the top of the reservoir, forcing the water into the cylinder and lifting the ram at almost any desired speed. As soon as the load becomes too great for this pressure, the air is by-passed into the air engine which in turn lifts the ram. In the jack illustrated, the ram raises at the rate of $7\frac{1}{2}$ in. per minute, whereas only 2 in. per minute is attainable with a hand power pump. This jack has a lifting capacity of 10 tons and a total raise of 103 in. The ram is telescopic in two lengths, 4 and 5 in.

are used for replacing wheels and axles on cars and locomotives. They are placed on a narrow gauge track in a pit below and perpendicular to the main track. The ram raises, catches the axle in a saddle mounted on its end, and lowers it clear of the chassis, then carries it to an out-of-the-way position at one side of the main tracks. This same type of jack is used for removing and placing heavy motors used on electric railway cars.

UNIVERSAL CUTTER AND REAMER GRINDER.

THIS machine is designed for sharpening straight or spiral milling cutters, face mills, end mills and straight or taper reamers, and will grind on centres a cutter 12 inches in diameter or a reamer 24 inches long. The

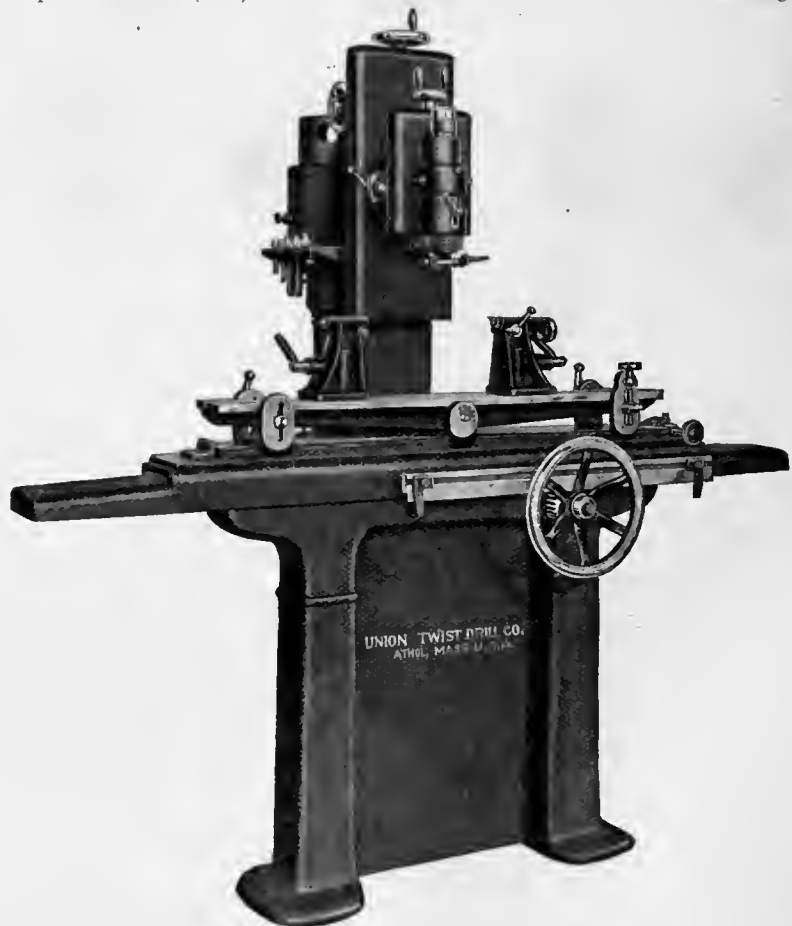

NO. 1 UNIVERSAL CUTTER AND REAMER GRINDER.

diameter, respectively, and since it is equipped with an air power pump, it embodies the latest feature in these tools.

As most railroad men know, pit jacks

cup form of wheel used gives a flat clearance and a stronger cutting edge than that resulting from a disc wheel.

The spindle is of steel, hardened and ground, and runs in bronze boxes, which

are provided with means of adjustment for wear, while the countershaft has tight and loose pulleys, 6 inches diameter for 2-inch belt, and should run 700 revolutions per minute.

The net weight of the machine is about 1,500 lbs., and occupies a floor space 35 x 96½ inches. For sharpening face mills and side teeth of side mills a suitable fixture can be furnished, and also a fixture for sharpening the end teeth of end mills.

The Union Twist Drill Co., Athol, Mass., are the manufacturers of this machine.



THE NEWEST SALESMAN.

THE J. W. Paxson Co., Philadelphia, Pa., have introduced a new method of showing their wares at the works of their patrons or at the most available hotel where a sheet may be hung, or a white wall be found, saving time and expense of the busy foundryman leaving his surroundings. This is accomplished by a new electric stereopticon, which may be attached to any electric lamp socket (direct or alternating current), when those interested may see the enlarged pictures on the screen, showing in detail the article itself in elevation and cross section, inside and out, and how made from the raw material to the finished product.

The salesman tucks this little stereopticon with the slides in his grip, together with price lists, thus enabling him to show and quote his prospective customer almost every article required in an iron, brass or steel foundry, including the buildings, laboratory, pattern shop, core room, core ovens, sand blast and overhead trolley installations, cupolas, blowers, linings, brass furnaces, tumbling barrels, sand sifters and mixers, ladles, magnetic separators, hay rope making, bellows, riddles and brushes, also facing mills, forge, boiler and machine shops, etc; the farms in R. L. N. Y., N. J., Penna. and Del., on which the sand, clay and core gravel originate, and some of the steam barges and tug boats that carry this commodity direct to the foundries at inside points along the rivers and canals and outside along the Atlantic Coast from New England States and Sound Ports to Philadelphia, Wilmington, Baltimore, Norfolk, etc.

To those about to install new equipment this idea will be appreciated, as more can be learned in five minutes than could in a week otherwise. The Paxson Company produce the equipment and supplies, make the photos and slides, and throw them on the screen, which they claim to be the new way to show goods. They are continually adding new slides to their collection.



Cobourg, Ont.—Mr. Justice Middleton has dismissed the action brought by Andrew Bashforth, formerly of Rotherham, England, against the Provincial Steel Co., Limited, with works at Cobourg. Bashforth sued for \$1,600, alleged due for salary as manager of the works and for profits. The judgment ran as follows: Judgment: It is impossible to lay down in any satisfactory way in general terms what will justify a discharge. Whereas here the employment is that of manager of an important branch of an undertaking such as this and where the failure results in a heavy financial loss, as was the case here, the unfitness here existing, Would to my mind, justify the discharge. In addition to this there was in this case, I think, such misconduct in reference to the matter alluded to as warrants dismissal. I think I shall be doing the plaintiff no injustice if I set off anything that may be due to him in respect of the minor claims put forward by him against the damages which he would be liable to pay upon the counter-claim. The loss in respect of the unauthorized expenditure on the residence building alone would more than counter-balance anything coming to him on this head. In the result the action fails and should be dismissed, with costs, if demanded. I would suggest to the defendants that they could well afford to be generous and to forego costs and any claim in respect of occupation rent of works house in occupation of plaintiff in view of the hardship upon the plaintiff by now having to begin again in England or elsewhere.

Toronto, Ont.—Chief Justice Meredith exploded the theory that the King cannot do any wrong, when he gave judgment against the Board of Governors of the University of Toronto, in favor of the plaintiff, William Scott, for \$600 for the loss of three fingers. The plaintiff, seventeen years of age, sued for the loss of three fingers of his left hand through injuries received while working as pressman in the University printing department on March 1st, 1912. Scott stated that he was ordered to oil the cylinder of the press, and while doing so the machinery started without warning, and the fingers of the left hand were drawn in and crushed so badly that all but the forefinger had subsequently to be amputated. The judgment was as follows:—Under the later legislation affecting the University and creating "the Governors of the University of Toronto," called "the board" in such legislation, they are made a legal entity, a corporate body

and being so incorporated and having expressly conferred upon them capacity to sue and be sued, and admitting as they do that the work in which the plaintiff was injured was their work and was under their control and that the persons engaged in it were their servants, this action is, I think, quite properly brought against them, in their corporate capacity, instead of against the university. The rule that the King can do no wrong does not apply to the Governors. They are not Crown officers. They are but officers of the university having power to deal with the property under their control for the use and benefit of the university only. The fiat of the attorney-General of the Province, giving leave to bring this action does not confer any right of action, it merely removes the legislative bar to the commencement of any action without such leave. Upon the merits of this case there is no liability at common law. There was no failure on the part of "the board" to supply proper machinery or to take any other reasonable precaution to insure the safety from injury in their employment of their servants. A foot-board was not a usual or indeed a proper part of a small machine such as that in which the plaintiff was hurt, nor would it have prevented such an accident as that in which he was injured. But under the workmen's compensation for injuries enactment the plaintiff has, as I find, a good cause of action against the defendants as such corporate body. The witness Edwards was a person employed by defendants, to whose orders the plaintiff in the same employment was bound to conform; the plaintiff was ordered by Edwards to oil the tympan of the press, and while conforming to that order by reason of conforming to it was injured through negligence of Edwards in setting the machine in motion without first giving the plaintiff some warning of his intention to do so. I cannot accept the statement of Edwards that his order was not to oil the machine, but was only to get ready to oil it. Such an order is improbable. The one difficulty on this branch of the case affects only the question of contributory negligence, and that is a very substantial difficulty, but upon the whole evidence my conclusion is that the defendants have not proved contributory negligence. Then what is in money a reasonable compensation? Under all the circumstances of the case I assess the damages at \$600. There will be judgment for the plaintiff and \$600 damages with costs on the High Court scale, and without any set off of costs. The action was commenced in the County Court and was brought up to this court by the defendant, and so as against them should be treated as properly a High Court case.

FOUNDRY PRACTICE AND EQUIPMENT

Practical Articles for Canadian Foundrymen and Pattern Makers, and
News of Foundrymen's and Allied Associations. Contributions Invited.

OPENING OF A FOUNDRY LABORATORY.

THE new laboratories of The H. M. Lane Co. were formally opened by a reception to the Detroit foundrymen on Saturday evening, March 22nd, which was attended by about one hundred people. These laboratories are the outcome of the research work which has been carried on by H. M. Lane during the past dozen years. They are located at 18 East Piquette Ave., Detroit, Mich., and occupy some 5,000 square feet of floor space.

A Coremaker's Lunch.

E. J. Woodison, of The E. J. Woodison Co., co-operated with the laboratory staff, furnishing the foundry supplies necessary in the laboratory and the material for the lunch. Refreshments were served from six to seven o'clock, the menu consisting of baked beans, baked potatoes, baked sausages, rolls, pickles, doughnuts, and coffee. Everything that could be baked was baked in a core oven, and the hosts even declared that the doughnuts were cooked in core oil. The oven used was a Crawford gas fired oven, and the temperature was regulated by a number of attached thermometers furnished by The Taylor Instrument Companies, of Rochester, N.Y. Each man's

lunch was placed in a new E. J. Woodison 16-qt. foundry pail, and according to the most modern core room methods, these were delivered to the visiting foundrymen by a gravity carrier. This full dinner bucket scheme goes the "serve-self" lunch one better, as the bucket first delivers the lunch and then becomes the diner's seat.

The Plant and Equipment.

At the front of the building are located the offices and draughting room, back of these being located the chemical laboratory, which is 15 by 40 feet. The remainder of the main building and the adjoining building are given up to the working core room and model foundry plant, containing the latest appliances in foundry equipment.

The objects of the laboratory are:

To study core sands and core binders, so as to find the best mixture for the conditions present in different plants.

To study new core binders in order to ascertain their exact value to the foundry.

To determine the best method of mixing sands and binders for different classes of cores or molds. A careful study is also made of the proper baking temperatures, baking times and different core oven fuels.

Special machinery is being installed in the laboratory for cleaning and re-

covering old core sand, and in the foundry department there is a melting furnace and appliances for pouring molds so as to test both cores and molds. A room at the rear of the building is fitted with microscopes and cameras for the study of core problems.

A Permanent Exhibit.

In this work, H. M. Lane has had the co-operation of a large number of manufacturers of equipment, and in the new laboratory, the working plan is as follows: The demonstration plant is run as a permanent exhibit, the manufacturers paying a definite sum per year for the exhibit privilege and supplying the laboratory with their latest equipment.

As the firm are consulting engineers, it is manifest that they could not accept commissions for equipment sold to their clients. This is clearly understood by the several manufacturers. The exhibition is of interest to manufacturers from three distinct angles: First, the research work being carried on in the laboratory is developing improvements upon existing machines and even developing some entirely new machines. Second, the equipment is being brought to the attention of an ever-increasing number of foundrymen who visit the plant, either as clients or simply to learn of the work which is being conducted. Third, one of the features of the exhibit is that the manufacturer showing equipment has the privilege of bringing prospective customers to the laboratory and there demonstrating his equipment as a part of a complete working model foundry. For instance, if the machine be a sand mixing machine, the mixed sand may be made into cores, baked and the cores tested or subjected to casting conditions.

Firms Furnishing Equipment.

The firms who have already furnished equipment are as follows: The Chicago Pneumatic Tool Co., Chicago, Ill.

The Cleveland Wire Spring Co., Cleveland, O.

The Mathews Gravity Carrier Co., Ellwood City, Pa.

The Monarch Engineering & Mfg. Co., Baltimore, Md.

The Osborne Mfg. Co., Cleveland, O.

The Palmer-Bee Co., Detroit, Mich.

The Oven Equipment & Mfg. Co., New Haven, Conn.

The W. W. Sly Mfg. Co., Cleveland, Ohio.



OPENING OF A FOUNDRY LABORATORY.

The Taylor Instrument Companies, Rochester, N.Y.

The U.S. Gas Machine Co., Muskegon, Mich.

The Vulcan Engineering Sales Agency, Chicago, Ill.

The Wadsworth Core Machine and Equipment Co., Akron, O.

The Wilson-Mauleen Co., New York City.

The E. J. Woodison Co., Detroit, Mich.

A number of other firms are planning to install exhibits in the near future.



ELECTROLYTIC GALVANIZING.

(Trunkhahn Patents.)

GALVANIZING is the best method for protecting iron and steel from rust. There exist two processes of galvanizing—the old "hot" process, by which the iron is immersed in molten zinc in which it is covered with a layer of spelter, and the new "electrolytic" process, by which the zinc coating is obtained from a solution of zinc salts by the electric current.

The hot process is not only costly in regard to the necessary plant and working expenses, but it also shows hygienic and technical defects which can be avoided by the use of the electrolytic or cold process. The former technical difficulties incidental to galvanizing by electro-deposition have been completely overcome, owing to the incessant work and the improvements performed by chemical experts, with the result that at present it is possible to turn out work with a smooth, close, non-porous covering of excellent bright appearance.

A circumstance which also retarded

the adoption of the electro-process to a larger extent was the fact that until recently the zinc coating obtained had a dull grey appearance, which was objected to by those who were used to the metallic polish of the hot galvanized ware. Mr. Trunkhahn, an Austrian chemist, has found an electrolyte by which it is possible to give the ware a high metallic polish in the bath itself, without any subsequent mechanical treatment being necessary. The "Trunkhahn" electrolyte is neutral in its chemical composition, which makes it superior to a number of other cold processes using acid solutions. Experience has shown that in solutions of this kind the oxidation of the iron in the bath commences before any deposition of zinc can take place, consequently the coating of zinc will be uneven and unreliable.

Disadvantages of Hot Process.

The hot process has the following principal disadvantages:—Irregularity of the thickness of the zinc covering. A much greater quantity of zinc is put upon the article galvanized than is necessary to protect it. The quantity of zinc cannot be controlled to suit work which is to be exposed to varying corroding conditions. The zinc covering is often chemically impure and contains small quantities of other metals. Under this condition it is more readily dissolved by acids than is pure zinc. In hot galvanizing, the superfluous zinc is removed before it is solidified, and results in the filling of any irregularities, but leaves the projecting parts with an inadequate covering. This particularly applies to tubes. Superfluous metal cannot be removed from the inside of the

tube in this way, and the coating is usually very irregular; in fact, small tubes from $\frac{3}{4}$ -inch diameter downwards require usually to have a bar passed through them to remove the superfluous lumps of zinc, and this adds considerably to the cost of manufacture.

By the hot process it is very difficult to get a coating of zinc through a small tube on account of the cooling effect of the iron or steel and the presence of air. Tubes and fittings have to be screwed after galvanizing, as the threads would otherwise be filled up by the zinc, thus leaving the weakest point unprotected. Hot galvanizing seriously deteriorates the quality of the iron or steel which is covered by it, and in hot galvanizing all the apparatus which comes into actual contact with the molten zinc is rapidly deteriorated. Hot galvanizing is also hygienically objectionable.

Advantages of the "Trunkhahn" Process.

The "Trunkhahn" process claims the following advantages:—By it the zinc covering is quite regular. As the deposition of zinc is under control, no superfluous metal is deposited and the process is highly economical. Zinc can be deposited to give any degree of protection in accordance with the purpose for which the article is intended. The zinc coating is chemically pure. In an article with an irregular surface (such as a hot-drawn tube which always has a striated surface) the covering is uniform and regular, leaving no one part more likely to be attacked than another. The inner coating of tubes is as perfect as the outer surface and does not need to be touched after galvanizing. Screw threads are covered as well as any other part, and the yielding nature of the zinc covering assists the making of tight joints. There is no deterioration of the quality of the iron or steel in this process. Owing to the process being carried on at a temperature little higher than that of the atmosphere, the apparatus is not subject to the deteriorating influences which affect the hot process. The Trunkhahn process is not unhealthy.

In addition to the above, the Trunkhahn process is claimed to have the following advantages:—A considerable saving in spelter amounting to 60 or 70 per cent. is effected. There is no continuous heating of the zinc bath; no noxious fumes of ammonia and chloride of zinc; no loss of zinc in the bath in the form of vapors; no burning of the material; no danger to workmen; and no expensive iron tanks which burn through after short use. A close deposit is formed, having a bright metallic polish. The cost of the necessary plant is low.



OPENING OF A FOUNDRY LABORATORY.

The MacLean Pub. Co., Ltd.

(ESTABLISHED 1888.)

JOHN BAYNE MACLEAN - - - - - President
H. T. HUNTER - - - - - General Manager

PUBLISHERS OF

CANADIAN MACHINERY AND MANUFACTURING NEWS

A weekly newspaper devoted to machinery and manufacturing interests, mechanical and electrical trades, the foundry, technical progress, construction and improvement.

H. V. TYRRELL - - - - - Business Manager

EDITORIAL STAFF:

PETER BAIN, M.E., J. H. WILLIAMS, C. W. BYERS

OFFICES:

CANADA

Montreal. Rooms 701-702 Eastern Townships Bank Bldg.

Toronto. 143-149 University Ave., Phone Main 7324

Winnipeg. 34 Royal Bank Bldg., Phone Garry 2333

Vancouver. H. Hodgson, 2640 Third Ave. West.

GREAT BRITAIN

London. 88 Fleet Street. E.C. Phone Central 12960
E. J. Dodd

UNITED STATES

New York. R. B. Huestis, 115 Broadway, New York, N. Y., Phone 2209 Rector

Chicago. A. H. Byrne Room 607, Marquette Bldg. 140 S. Dearborn St., Chicago

CABLE ADDRESS:

Macpubco, Toronto. Atabek, London, Eng.

SUBSCRIPTION RATE:

Canada, \$2.00; United States, \$2.50; Great Britain, Australia and other colonies, 8s. 6d. per year; other countries, \$3.00. Advertising rates on request.

Subscribers who are not receiving their paper regularly will confer a favor on us by letting us know. We should be notified at once of any change in address, giving both old and new.

Vol. IX.

APRIL 10, 1913

No. 12

PRINCIPAL CONTENTS.

Design and Construction Features of Modern Shop Cranes.....	369-372
General.....	372
G.T.P. Construction... Advertising.....	
Typical Methods of Attaching Chucks to Lathe Spindles.....	373
General.....	373-374
Building for Plant Required... Cast-Roll Chilling Process... Opening of C.P.R. Shops at Ogden, Alta....	
Hydro-Electric Contracts... The Art of Choosing Men.	
Illumination of Factories and Engineering Workshops.....	375-377
General.....	377
Fire Risks in Machine Shops... A Successful Profit-Sharing System.	
The Question of System and Costs in the Repair Shop.....	378-379
The Decadence of the Machinist and Fitter.....	379-380
Application of Electric Motors to Woodworking Machines.....	380
Machine Shop Methods and Devices.....	381-383
Home-made Fixture for Drilling Cylinders... Drawing Shells... Milling Fixture for Crank Gear Case... Drilling jig for a Crank Case... Increased Screw Machine Production... Multiple Spindle Drill Adapter.	
Developments in Machinery.....	384-385
Improvement in Hydraulic Pit Jacks... Universal Cutter and Reamer Grinder... The Newest Salesman.	
Recent Judicial Decisions.....	385
Foundry Practice and Equipment.....	386-387
Opening of a Foundry Laboratory... Electrolytic Galvanizing.	
Editorial.....	388
Industrial and Construction News.....	389-392
Selected Market Quotations.....	393-394
General Market Tendencies.....	394

THE WORKMEN'S COMPENSATION ACT.

AT the outset we congratulate the Whitney Government of Ontario for its broadmindedness in framing the advanced social legislation promised in the Workmen's Compensation Act. The measure has not yet taken passed, but from outlines given by the commissioner, we believe it to be a step in the right direction. Congratulations also to Sir William Meredith for the splendid way in which he has conducted the hearings of the commission. Sometimes he was a trifle sharp, but his treatment of all sides was the same.

Looking at the Act as it emerges in its rough state, we see features in it which cause us to ask "Why?" Why are the railways and steamship companies grouped under an individual liability system, and the manufacturers

under a collective system? We have searched the records of the hearings, and we find this justification in the words of Sir William himself: "I am not in favor of the railways being brought within the scope of the Act yet awhile. We might as well leave that to the commission; but, of course, they will be more or less under the control of the Act later on." Sir William has reiterated that the whole business is merely an experiment, and from this statement, one gathers that the railways will, some day, be gathered into the same group as the manufacturers.

The C.P.R. argue as follows: "The interests of employer and employe, and of the general public as well, would be better served by a system of simple compensation, whereby each individual employer of labor would be liable for those injuries suffered by workman in his own employment. We object strenuously to any plan whereby we would be compelled to contribute to a State insurance fund, or be forced to share the accident liabilities of other railways." Apparently this has had its effect on the Commissioner, for, under his scheme, the C.P.R. and the other railways will be allowed to handle their own liability affairs, though on a basis suggested by the commission. We hope that the commission of three appointed by the Lieut.-Governor will see to it that this basis will be as nearly identical to that delegated to the manufacturers as possible.

As the act now stands, the manufacturers will pay into a common fund. The idea is distasteful to them. Might not the boilermaker with equal justice argue that the patternmaker has not as good safety appliances as he, and that consequently he refuses to share the accident liabilities of the other? That is exactly the argument put up by the C.P.R. against joining with the other railways? As we read the Act, provision is made that a manufacturer who runs a hazardous business, who kills and maims more than another employer, has to pay a higher assessment into the general fund. Therefore, the C. P. R., with its professed perfect life saving devices, would have stood a good chance of getting off cheap.

Much objection has been raised by the Canadian Manufacturers' Association to paying into the fund on the capitalized system; they would rather meet the needs of the fund under a current costs fund. Their claim is that the former would unduly bear on manufacturers at the inception of the system. The other system would allow them to form mutual associations to reduce the cost. Sir William's reply to this was: "I have no objection to the manufacturers taking these grounds, but this is not something solely for the benefit of the manufacturers. This is in the interest of the people, and what the people say must be done." At another time, he observed that the money would not go into the cellar, but would go back into use.

As this has come to be one of the crucial points of the situation, it should be carefully considered by the Legislature, and some concession made to the manufacturers if possible. The individual liability system is bad. Legislation all over the world is tending towards the collective system, but the object of the Act is not to harass manufacturers. In our opinion, it will be a great boon to them. It strikes a death blow to expensive litigation and ruinous lawyers. Therefore, if there is a desire on the part of the Legislature to help the manufacturers, they should be allowed to arrange matters so that this extra tax will not be overburdensome to begin with.

Lastly, "lump sum" compensation is to be tabooed. At one of the hearings, a railway employe emphatically declared that if compensation took the form of a pension, he would not favor the Act. He was promptly "sat upon" by Sir William, and deservedly. The legislation is primarily intended to prevent the workingman from becoming a burden to the community, and not to encourage the squandering of money.

INDUSTRIAL ^A_N^D CONSTRUCTION NEWS

Establishment or Enlargement of Factories, Mills, Power Plants, Etc.; Construction of Railways, Bridges, Etc.; Municipal Undertakings; Mining News.

Engineering

Sault Ste. Marie, Ont.—A fire did considerable damage to the Lake Superior Corporation plant on March 21.

Ottawa, Ont.—Round house and car shops are planned by the Canadian Northern Railway, in Rideau Township, work will commence in the spring.

Brandon, Man.—The Brandon Wire & Stamp Co. will commence operations next week. For the present the firm will manufacture lightning rods. A new plant will be built next fall.

Fort William, Ont.—Plans are in progress for the erection at Fort William of a factory, at a cost of \$40,000, for the International Harvester Co., of which H. H. Biggert is general manager.

Medicine Hat, Alta.—A foundry to employ 100 men will be erected at Medicine Hat, by the Medicine Hat Radiator Co. L. Carey Wright, Sank Centre, Minn., is president of the operating company.

London, Ont.—The National Brass Mfg. Co., has been organized here with a capital of \$40,000 to engage in the manufacture of plumbers' supplies. The directors include John F. Grant, Charles H. Ivey and John O'D. Dromgole.

Montreal, Que.—For the addition to Angus car shops of Canadian Pacific Railway the builders are D. G. Loomis & Sons, St. Patrick Ave., and Lacey R. Johnson is general superintendent. Sub-tenders received by general contractors.

Montreal, Que.—It is believed that the Canadian Pacific management are planning new shops near Toronto, where engines and cars of all kinds will be built on an extensive scale, including steel express, passenger, sleeper and diner cars.

Niagara Falls, Ont.—The Dominion Chain Co. new building, measuring 40 x 100 ft. and having an up-to-date saw tooth roof, will be completed in about two weeks. It is quite possible that the main factory will be ultimately established here.

Chatham, Ont.—The Steel Bending Brake Works, Chatham, Ont., has been organized with a capital of \$35,000, and will establish a factory to manufacture metal brake machines. Herman K. and Walter H. Dreis and Herman Krump are interested.

New Glasgow, N.S.—The output of the Nova Scotia Steel & Coal Co. for March was:—Coal mined, 64,000 tons; ore mined, 52,625 tons; pig iron made, 7,200 tons; steel ingots made, 7,200 tons. The company will build a new open-hearth furnace at Sydney mines this year.

Vancouver, B.C.—The Taylor Engineering and Manufacturing Co. has been awarded the contract for the entire smelting equipment and a new 2,000 ton copper smelter and converting plant which the Granby Consolidated Mining, Smelting and Power Co. is erecting at Anyox, B.C.

The Conover-Overkamp Machine & Tool Co., Dayton, Ohio, state, for the benefit of their Canadian patrons, that although in the midst of the recent disastrous floods at Dayton, their machinery, tools, drawings and most of their patterns are saved. They have a full force at work cleaning up the shops and will be in operation as soon as the power plant is rebuilt.

Owen Sound, Ont.—Work on the new plant of the Canadian Malleable Iron Company is being rushed, and it is expected that the first finished product will be shipped by the middle of April. The plant will open with an initial force of 150 men, and this will be swelled on completion of the third unit to 250 or 300 men.

Red Deer, Alta.—Factories, measuring 40 x 150 ft. and 40 x 60 ft. as well as a machine shop and foundry, are being built by the Red Deer Holdings Co. A \$12,000 order for machinery has also been placed, and will be on the road to Red Deer in a short time now. This includes hammers, lathes, drills, bulldozer, punches, alligator shears, etc.

Bridgeburg, Ont.—The Chicago Bridge and Iron Works who have purchased seven acres of land, have started work on their factory. The one story building, with dimensions of 100x 160 ft. will cost between \$15,000 and \$25,000. They will enlarge their plant as their trade increases. Chief Superintendent R. H. Murray of Chicago and Supt. C. C. Gregory for the local plant are on the ground.

Windsor, Ont.—The directors of the Chicago Pneumatic Tool Co. are considering the building of a plant in Canada, probably near Windsor, Ont., large enough to handle its Canadian business, the cost to be between \$300,000 and \$400,000. The company has a small plant near Montreal, equipped only for repair work. Funds on hand are ample to meet the cost, and construction will be started probably during the coming summer. Present plants are operating at practically full capacity with orders for months ahead. Difficulties are being met in obtaining deliveries of steel.

Electrical

L'Avenir, Que.—The L'Avenir Telephone Co., has recently been organized and is inviting the supply of general telephone equipment.

Moose Jaw, Sask.—The Railway Accessories Co., Seattle, Wash., plan to establish a branch here for the manufacture of railway supplies.

Sackville, N.B.—The Canadian Appraisal Co., of Montreal, will send a man here to appraise the lighting plant which the city contemplates purchasing.

Montreal, Que.—Plans are being prepared for a telephone exchange at a cost of \$100,000. W. Carmichael, Notre Dame and St. John Streets, Montreal, has charge of the plans.

Brantford, Ont.—Residents of Brantford Township in Echo Place, a suburb of the city, have petitioned for the installation of Hydro power. Parkdale and Grandview will follow.

Montreal, Que.—Allis-Chalmers Bullock shareholders will be asked on April 14th to consider a plan for selling the company's entire property, and to authorize the directors to complete arrangements for same.

Montreal, Que.—The Sherbrooke Railway & Power Co. have just completed a contract for 500 additional h.p. to be delivered to a new company about to start operations in Sherbrooke. The contract calls for delivery of power by the fall. This makes 3,000 h.p. the company has now under contract, or about three-quarters of its total output.

General Industrial

Amherst, N.S.—The Amherst Piano Co., Ltd., will commence building their new plant this spring.

New Glasgow, N.S.—The Nova Scotia Steel & Coal Co. will open up a new colliery at Sydney mines.

Brampton, Ont.—The Road Committee will purchase a cement mixer for \$750 for cement roads. L. J. C. Bull is chairman.

Moose Jaw, Sask.—Additions which will cost \$15,000, are being made to the factory of the Saskatchewan Glass Supply Co.

Waterford, Ont.—The Canadian Canners, Ltd., are preparing to erect an addition to the factory here, to handle peas and corn.

Hebron, Que.—Shoemaking machinery will be acquired by the H. H. Crosby Co., of Hebron, who are planning an addition to the factory.

Wrightville, Que.—McLaren & Co. will buy property here to re-establish their woollen mills and sash and door factory, burned at Wakefield three years ago.

Hamilton, Ont.—The Hamilton Ideal Mfg. Co., manufactureres of the Ullman cash registers, hay and grain unloaders, etc., are having plans prepared for an addition to its plant.

Toronto, Ont.—Messrs. Rolph & Clark Ltd., lithographers, are constructing a new plant, and have recently bought more land for an extension on Carlow Ave.

Sault Ste. Marie, Ont.—Fire at the charcoal plant of the Lake Superior Corporation on March 31, did considerable damage. The loss is covered by insurance.

Prescott, Ont.—P. J. Maloney, a silk manufacturer of Paterson, N.J., has concluded negotiations for the establishment of a ten loom silk mill, employing 30 hands here.

Peterborough, Ont.—The Vermont Marble Company, with head office at Procter, Vt., will locate in this city. The cost of building, machinery, and plant will be about \$20,000.

St. John, N.B.—Secretary Hoag of the Board of Trade, conducted B. S. Blackadar, of New York, representing a large leather and rubber firm, over the city last week in search of a suitable site.

Toronto, Ont.—The American Watch Case Co. intend building a four-storey brick stone, and steel factory on King

Street. The new building will cost \$15,000. A permit to this effect has been granted.

Brantford, Ont.—The civic authorities will protest against the removal of the Dominion Gas Co.'s books from this city. That company was incorporated with others into the Henry L. Doherty Co., of New York.

Toronto, Ont.—The Benedict Mfg. Co., Syracuse, N.Y., manufacturers of silver plate, bronze, brass and metal goods, will establish a Canadian factory here, to be known as the Benedict Proctor Co., Ltd. L. G. Proctor, Toronto, is president of the Canadian concern.

Victoria, B.C.—The Canadian Explosives Co., Ltd., will shortly establish new headquarters for the manufacturing of its products on James Island. The company will spend nearly \$1,000,000 in construction of buildings, installation of the latest machinery etc.

Port Arthur, Ont.—The elevator storage capacity here was increased by three million bushels last week, when the machinery in the new annex of the huge Canadian Northern plant was put in operation. The plant is still the largest in the world with a total storage capacity of about nine and one-half million bushels.

Quebec, Que.—Work on the construction of the mills for the Donauconâ Paper Co. is progressing very satisfactorily, and considerable headway has already been made. The site of the mills is situated above Quebec, between Les Eeneuils and Cap Sante, at the mouth of the Jacques Cartier River, where it empties into the St. Lawrence.

Montreal, Que.—Work has begun on a \$250,000 plant by the National Builders' Supply & Enamel Concrete Brick Co., at Mascouche, Que. This company, with head offices at Montreal, has applied to the Dominion Government for an increase in capitalization to \$1,000,000. Sites have been secured and plants will be erected in Ottawa and Toronto.

New Glasgow, N.S.—A local company have purchased the sand plant and light-house beach from Messrs. Sproull at Picton Landing, and in addition will operate a crushed stone plant on the Sunny Brae Railway. The company is composed of Gammon & Weir, Messrs. McColl and Chambers, of the Steel Works and Mr. Evans of the Aeadia Coal Co.

Companies Wound-up.—At special meetings of the shareholders of the following companies, resolutions were passed that the companies be wound-up, and that the Canada Trust Co. be ap-

pointed liquidators for the purpose of winding-up the affairs of the corporations, and distributing the properties: The London Fence Machine Co., The H. R. Lamb Fence Co., Ltd., and The International Fence Co.

Red Cliff, Alta.—Hammond Stooker Co., of Winnipeg, have signed a contract with Mayor Danelz to build a \$250,000 plant there at once. R. Hammond, manager of the Hammond Stooker Company, which has offices in the Sylvester-Willson building, Winnipeg, confirmed the above report, and stated that the property purchased was 10 acres, on which a building and machinery to the value of \$250,000 would be placed.

Fort Frances, Ont.—The George Irish Paper Co., of Buffalo, N.Y., is contemplating the erection here of a plant for the manufacture of book and wrapper paper. It is not certain yet whether this mill will be built here or at International Falls. Lewis F. Houpt is the president of the company. J. A. Osborne, secretary of the Board of Trade, has received promises from a Toronto concern to erect a sugar beet plant here.

London, Ont.—The McCormick Biscuit Co. have just begun to break ground in the east end of the city for their immense new factory, which will cost over \$260,000. The new factory of the Kellogg Toasted Corn Flake Co. is almost ready for occupation. The Empire Manufacturing Co. are going to enlarge their plant this summer, and the Richards-Wileox Canadian Co are already occupying their new place here. E. Leonard & Sons, engine and boiler manufacturers, are going to build a large new plant in the east end of the city this year also.

Municipal

Strassburg, Sask.—A by-law will be submitted to the burgesses on April 14 calling for the raising of \$12,000 to cover cost of an electric light system.

The City of Brandon, Man., has passed a by-law to make the city electrician the ascertaining and determining officer with regard to local improvements of standard street lighting, instead of the city engineer.

Winnipeg's Water Problem.—The board of consulting engineers for the proposed Greater Winnipeg water district scheme will consist of Frederick P. Stearns, of Boston, Mass., who has been one of the consulting engineers of the Panama Canal, the Los Angeles aqueduct, and the New York aqueduct; Rudolph Herring and James H. Fuertes,

both of new York, who were members of the 1907 board. The board will assemble in Winnipeg on May, 10.

North Vancouver, B.C.—Following are the by-laws recently voted on by the burgesses and passed;—To raise \$6,000 for acquisition of machinery; \$32,000 re waterworks system; \$27,000 for street improvement purposes; \$32,000 re construction of a storage reservoir; \$5,000 re lanes; \$28,000 re construction of subway; \$150,000 for shares in the Burrard Inlet Tunnel and Bridge Company; \$140,000 re school expenses; and \$75,000 for site for new central school.

Railways - Bridges

Le Pas.—The last rail across the Saskatchewan river on the Hudson Bay Railway bridge was spiked last week.

Masonville, Que.—An iron bridge with concrete abutments will be erected this summer by the municipal council. Engineer, L. A. Vallee.

Cochrane, Ont.—The contractors on the G.T.P. promise completion of the remaining portion of the Cochrane-Quebec connection by September next.

Fredericton, N.B.—On March 24 the Connors bridge across the Salmon River, about five miles above Chipman, in Queens county, had three spans carried away.

Bolton Centre, Que.—A bridge is planned by the municipal council to replace "David Holland" structure swept away. Further particulars from the sec-treas., Bolton Centre.

Saskatoon, Sask.—The city will be building another bridge across the river shortly. A by-law will be submitted to the people to provide for a larger expenditure on sewers and watermains.

Levis, Que.—The new bridge south of the new Quebec bridge was endangered by the abnormal rise of the Chaudiere River. M. P. and J. T. Davis have been working since January, strengthening the abutments.

Victoria, B.C.—The new steel trestle bridge which is being erected on the Esquimalt and Nanaimo Railway line at Arbutus Canyon is making excellent progress. The work is in the care of Messrs. C. P. Doe & Company, contractors.

Building Notes

Saskatoon, Sask.—A company will build a \$150,000 theatre to seat 1,500. Charles Angle, proprietor of the Empress theatre is behind the proposition.

Saskatoon, Sask.—Thompson and Crockart are architects for the Royal North-West Mounted Police barracks, which will cost \$20,000, frontage 65 ft.

Toronto, Ont.—The contract for the construction of the new cathedral of St. Alban the Martyr, to cost in the neighborhood of \$500,000 has been let to Messrs. Elgie & Page.

Ottawa, Ont.—Tenders for the erection of a public building, at Brachbridge, Ont., will be received up to April 28, by the Department of Public Works. R. C. Desrochers, secretary.

Brockville, Ont.—The contract for the erection of a hotel to replace the Columbian Hotel at Thousand Island Park, which was burned last year will be let to a Philadelphia firm.

The Jeffrey Manufacturing Co. are grateful to their numerous Canadian customers and friends for the patience and indulgence extended, through their being involved in the recent disastrous floods at their headquarters plant, Columbus, Ohio.

Vancouver, B.C.—Plans have been prepared for Woodward's Departmental Store, ten storeys high. Rapid service elevators, the best of heating appliances have been incorporated in the plans.

Ottawa, Ont.—Tenders for 12 Stall Engine House without Machine Shop, to be erected at O'Brien, Que., will be received at the office of the Commissioners of the Transcontinental Railway at Ottawa, until April 30. P. E. Ryan, secretary.

Wood-Working

Halifax, N.S.—On April 1 the wood-working plant of the Rhodes-Curry Co. was destroyed by fire. Loss \$50,000, insured.

Tenders

Fort William, Ont.—The Board of Control has called for tenders for a quantity of 36-inch cast iron pipe up to April 15.

North Vancouver, B.C.—The city council welcome propositions, good for three weeks from March 27, for a gas plant for the city. Any proposal, whether for a municipal plant or a company operated concern, will be carefully weighed.

Victoria, B.C.—Tenders will be received up to May 7 by the Minister of Public

Works, for the complete sub-structure and its erection, for the steel super-structure, and for a concrete arch, for a steel bridge across the Thompson River at Lytton, B.C. J. E. Griffith, public works engineer.

Montreal, Que.—The Board of Control will call for tenders for the construction of the underground conduit in St. Catherine street between Papineau avenue and Guy street. The specifications and plans have been prepared by the Electric Service Commission and they require the removal of all overhead wires, save those required for the actual operation of trolley cars, into the municipal conduits.

Tenders are to be submitted by April 25.

Lindsay, Ont.—The town invites tenders for the construction of approximately 25,000 square yards of permanent roadways, of which about 17,000 square yards will be laid on business streets, and about 8,000 square yards on residential streets. Parties tendering will specify the kind of permanent roadway they propose to construct, the cost for square yard, including kerb, and the guarantee as to durability. Richard Kylie, Chairman Board of Works, Lindsay.

Simcoe, Ont.—Tenders will be received by the Town Clerk until April 23rd, for the following material: Contract A—Laying main sewer and sewage force main. D.—Furnishing cast iron pipes. G.—Sewage pumping machinery. P.—Sewage pumping station. S.—The sewer pipes. X.—Sewage disposal works. Plans and specifications may be seen at the office of the Engineers, Toronto, or at the Town Hall, Simcoe, Ont. C. Gibson, Mayor. W. C. McCall, Town Clerk. Chipman & Power, Engineers, Toronto.

Contracts Awarded

Winnipeg, Man.—Thos. Kelley & Sons have secured the contract for a \$34,000 sewer, 2,550 feet long, from this city.

Ottawa, Ont.—The Postmaster-General has awarded a contract for 350,000 mail-bag locks at \$1 each to the Ontario Equipment Co.

Ottawa, Ont.—The Postmaster-general has awarded a contract for 350,000 locks and keys for mail bags at a cost of a dollar apiece.

Quebec, Que.—The contract for the highway between Quebec and Montreal has been secured by H. Beauregard, Montreal, for \$1,500,000.

St. Anselme, Ont.—The Sherbrooke Iron Works, Ltd., has been awarded the contract for steel bridges to be constructed across the Etchemin river at a cost of \$16,000.

Toronto, Ont.—The Canada Foundry Co. has been awarded a contract by the Canadian Government for 10 freight engines for the Intercolonial railway at \$24,500 each.

Thorold, Ont.—The contract for the building of the window glass plant of Pilkington Bros., England, has been awarded to the Samuel Austin & Son, Company, of Cleveland.

Ottawa.—The Canadian government has ordered from the Pullman Co., of Chicago, for the International railway, two dining cars at \$29,500 each, and three sleepers at \$30,875 each.

Hamilton, Ont.—The contract has been let for the electric pumping station to cost \$20,000, planned by Board of Control. General contractor and mason, Geo. E. Mills, 614 King street east.

Sutherland, Sask.—Contract for the sewage disposal tanks costing \$45,000 has gone to Edmund T. Sykes of Neepawa, Man. J. Browley, of Fernie, B.C., has secured contract for sewers, manholes, etc.

Toronto, Ont.—The contract for the piers and abutments for the St. Clair avenue bridge was let to Messrs. Scott and Law, Confederation Life Building by the Board of Control, the work to cost \$27,000.

St. John, N.B.—Messrs. B. Mooney & Sons have been awarded the contract for a new stone church to be built at Renous, Northumberland County, by Rev. E. S. Murdoch. The church will cost \$25,000.

Niagara Falls, Ont.—The contract for the supply of cast iron pipe for all the work during the year has been awarded the United States Pipe Company, of Buffalo. The contract for service pipes was given Gainer Bros.

London, Ont.—Watt & Blackwell, architects, awarded the contract for the McCormick plant in East London to the Canadian Frost and Winchester Co., Montreal, for the sum of \$260,000 approximately.

Montreal, Que.—The city of Moose Jaw has awarded the contract for supplying a new 1,500 k.w. turbo-generator to the Sieman's Company of Canada, Limited. The machine will be run at 3,600 r.p.m., and will be suitable for 3-phase, 60 cycle circuit.

Ottawa, Ont.—The government have awarded the following important contracts:—MacDougall Brothers, of Ottawa, were awarded a contract for lock, dam, etc., at New Glasgow, N.S., for \$390,000. Cammel, Laird and Co., ship-builders, were awarded a contract for a new ice-breaking steam ferry, for use

between Quebec and Levis, costing \$588,000.

Calgary, Alta.—Recommendations for the purchase of machinery, etc., for No. 2 paving plant, amounting in all to \$17,285, have been made to the council by the commissioners. The following firms have been given the business: Gorman, Clancy & Grindley; Mussens, Ltd.; Canadian Fairbanks-Morse & Co., Ltd.; Western Supply & Equipment Co.; P. D. MacLaren & Co., and E. Leonard & Son.

London, Ont.—The board of works of the city council, and the jail committee of the county council, have let contracts amounting to \$35,383 for repairs and alterations to the courthouse and jail. The items were as follows: Brick work, Copp Bros., \$678; carpenter work, H. Tozier, \$10,984; painting and plastering, Fitzgerald & Corpe, \$2,600; plumbing, Noble & Rich, \$6,187; iron stairs, Dennis Wire and Iron works, \$3,000; plastering, H. Stratford, \$7,075; vault fittings, Office Specialty Company, \$2,295; tiling, Kutz & Co., Toronto, \$2,564.

New Westminster, B.C.—Contracts for material and equipment to be used in connection with the harbor work, aggregating in value over \$130,000 have been let as follows: Dredge hull, Star Shipyard Company, \$8,988.75; 150 horsepower electric hoist, Allis-Chalmers-Bullock, \$6,569, with discounts 150 horse power electric hoist. Taylor & Young, Vancouver, \$5,142.55, with discounts; tug Hero, without boiler, Thomas Appleton, \$6,000; steam hoisting engine, Washington Iron Work, Seattle, \$4,050; tubular boiler, Vulcan Iron Works, \$2,900; piling for quay front, Waugh, Meisener and Bailey, Vancouver, over \$100,000.

Trade Gossip

The Cleveland Foundry Co., Cleveland, O., manufacturers of blue flame oil cooking stoves, oil heating stoves, and cooking utensils, advise that they will establish a branch concern in Canada, but will not decide in the location for some months yet.

Alfred Herbert, Ltd., Coventry, England, whose Canadian agents are Mussens, Ltd., Montreal have just sent us a copy of their calendar for 1913. This is a handsome production printed in bold type on faced paper and is illustrated by excellent half tone views of portions of the firm's works and also of their leading lines of machine tools.

W. S. Beath & Son, Toronto, have been given the exclusive agency in Canada for the cranes manufactured by Alfred Box & Co., Philadelphia, Pa. Bulletin No. 404, issued by this firm is to hand. There is little reading matter,

just sufficient to give a clear idea of what may be expected from Box Cranes, the photographs do the rest.

Personal

A. E. Armitage has been appointed superintendent of works for Sutherland, Sask.

R. H. Thomson and City Engineer Rust, of Victoria, have been named to investigate the Greater Vancouver sewerage proposals in behalf of the provincial government.

John Shore, late Superintendent of the Edmonton Iron Works has accepted the position of manager with the Red Deer Machine Co., Red Deer, Alta., who make the Van Slyke Plow.

Chas. M. Schwab resigned last week as president of the Bethlehem Steel Company to become Chairman of the Board of Directors of the same Company. E. G. Grace was elected President in his stead.

H. R. Parsons, C. E., late assistant city engineer, Ottawa, has been appointed city engineer of Peterborough at a salary of \$2,500. The services of T. A. S. Hay, the present incumbent, will be retained at an advanced salary.

H. B. Douglas has accepted the position of manager of the Eastern Car Co., New Glasgow, N.S. He was formerly manager of the Standard Steel Car Co. at Hammond, Ind. The plant at New Glasgow is rapidly nearing completion.

E. B. Blackwell has been elected managing director of the Canadian Willamette Co., Ltd., Vancouver, B.C. This company will manufacture an engine, which will be a duplicate of that made by the Willamette Iron & Steel Works, Portland, Ore. Mr. Blackwell has been selling agent of the Willamette Iron & Steel Works for the past seven years.

W. L. Richardson, for the past eight years superintendent of manual training in the public schools of Toronto, has been offered and has accepted the position of director of industrial education for the city of Edmonton, Alberta. Mr. Richardson will receive a salary of \$3,000 in his new position, an increase of \$600 over the salary he received in Toronto.

Obituary

James Bannan, chief engineer at the Toronto City Hall, died on Wednesday, April 2, after an illness of several months. The deceased had been in the city's employ for about twelve years.

SELECTED MARKET QUOTATIONS

Being a record of prices current on raw and finished material entering into the manufacture of mechanical and general engineering products.

PIG IRON.

	Per Ton.	
Foundry No. 1 and 2, f.o.b., Midland	\$19 25	\$20 50
Gray Forge, Pittsburgh	16 75	
Lake Superior, charcoal, Chicago	18 00	
	Mont'l.	Tor'to.
Canadian f'dry, No. 1..	\$20 50	\$20 50
Canadian f'dry, No. 2..	20 00	20 00
Middlesboro, No. 3....	23 50	23 50
Summerlee, No. 2	25 00	26 50
Carron, special	25 00
Carron, soft	25 00
Cleveland, No. 1	24 25	25 00
Clarence, No. 3	23 75	24 50
Jarrow	25 50
Glengarnock	26 00
Radnor, charcoal iron.	30 00	34 50
Ferro Nickel pig iron (Soo)	25 00

BILLETS.

	Per Gross Ton.	
Bessemer billets, Pittsburgh	\$28 50	
Open hearth billets, Pittsburgh	29 00	
Forging billets, Pittsburgh	36 00	
Wire rods, Pittsburgh	30 00	

FINISHED IRON AND STEEL.

Per pound to large buyers:

	Cents.
Common bar iron, f.o.b., Toronto..	2.10
Steel bars, f.o.b., Toronto.....	2.20
Common bar iron, f.o.b., Montreal.	2.15
Steel bars, f.o.b., Montreal.....	2.25
Bessemer rails, heavy, at mill....	1.25
Iron bars, Pittsburgh	1.70
Steel bars, Pittsburgh, future	1.40
Tank plates, Pittsburgh, future....	1.45
Beams, Pittsburgh, future	1.45
Angles, Pittsburgh, future	1.45
Steel hoops, Pittsburgh	1.60

Toronto Warehouse f.o.b., Toronto.

	Cents.
Steel bars	2.30
Small shapes	2.40
Warehouse import, freight and duty to pay:	Cents
Steel bars	1.95
Structural shapes	2.05
Plates	2.05
Freight, Pittsburgh to Toronto:	
18 cents carload; 21 cents less carload.	

BOILER PLATES.

	Mont'l.	Tor'to.
Plates, 1/4 to 1/2-in., 100 lbs.	\$2.40	\$2.40
Heads, per 100 lbs.....	2.65	2.95
Tank plates, 3-16 in.....	2.60	2.60
Tubes, per 100 ft., 1 inch	9.00	8.50
" " 1 1/4 in.	9.00	8.50
" " 1 1/2 "	9.00	9.00
" " 1 3/4 "	9.00	9.00
" " 2 "	9.00	9.00
" " 2 1/2 "	11.50	11.50
" " 3 "	12.00	12.00
" " 3 1/4 "	13.75	13.75
" " 3 1/2 "	15.00	15.00
" " 4 "	18.50	18.50

BOLTS, NUTS AND SCREWS.

	Per cent.
Stove bolts	80 & 7 1/2
Machine bolts, 3/8 and less	65 & 5
Machine bolts, 7-16.....	57 1/2
Blank bolts	57 1/2
Bolt ends	57 1/2
Machine screws, iron, brass	35 p c.
Nuts, square, all sizes.....	4c per lb off
Nuts, Hexagon, all sizes..	4 1/4 per lb off
Flat and round head.....	35 per cent.
Fillister head	25 per cent.
Iron rivets	60, 10, -0 off
Wood screws, flathead, bright	85, 10 p c off
Wood screws, flathead, brass	75, 10 p c off
Wood screws, flathead bronze	70, 10 p c off

National-Acme "Milled Products."

Sq. & Hex Head Cap Screws	65 & 10%
Sq. & Hex Head Cay Screws	65 & 10%
Rd. & Fil. Head Cap Screws	45-10-10%
Flat & But. Head Cap Screws	40-10-10%
Finished Nuts up to 1 in. . .	75%
Finished Nuts over 1 in. . .	72%
Semi-Fin. Nuts, up to 1 in....	75%
Semi-Fin. Nuts over 1 in....	72%
Studs.....	65%
Discounts f.o.b., Montreal.	

WROUGHT IRON PIPE.

The following are Toronto jobbers' discounts on pipe. (Card weight) in effect from October 11th, 1912:

	Standard	Buttweld Black Gal.	Lapweld Black Gal.
1/4 3/8 in.	63	48
1/2 in.	68	58
3/4 to 1 1/2	72 1/2	62 1/2
2 in.	72 1/2	62 1/2	69 1/2 59 1/2
2 1/2 to 4 in. . .	72 1/2	62 1/2	71 1/2 61 1/2
4 1/2 to 6 in.	72	62
7, 8, 10 in.	66 1/2	54 1/2

X Strong P. E.

1/4, 3/8, 1/2 in. . .	64	54
3/4 to 2 in.	68	58
2 1/2 to 3 in.	68	58
3 1/2 to 4 in.	65	55
4 1/2 to 6 in.	63 1/2	56 1/2
7 to 8 in.	56 1/2	46 1/2

XX Strong P. E.

1/2 to 2 in.	43	33
2 1/2 to 4 in.	43	33

WROUGHT IRON PIPE.

The following are Montreal jobbers' discounts on pipe. (Card weight) in effect from October 11th, 1912:

	Standard	Buttweld Black Gal.	Lapweld Black Gal.
1/4 3/8 in.	64	49
1/2 in.	69	59
3/4 to 1 1/2	73 1/2	63 1/2
2 in.	73 1/2	63 1/2
2 1/2 to 4 in. . .	73 1/2	63 1/2	72 1/2 62 1/2
4 1/2 to 6 in.	74	64
7, 8, 10 in.	70 1/2	58 1/2

X Strong P. E.

1/4, 3/8	64	49
1/2 in.	65	55
3/4 to 2 in.	69	59
2 1/2 to 3 in. . .	69	59
3 1/2 to 4 in.	66	56
4 1/2 to 6 in.	65 1/2	58 1/2
7 to 8 in.	60 1/2	50 1/2

XX Strong P. E.

1/2 to 2 in.	44	34
2 1/2 to 4 in.	44	34

IRON PIPE FITTINGS.

Canadian malleable, 40 per cent.; cast iron, 65; standard bushings, 70; headers, 60; flanged unions, 65; malleable bushings, 65; nipples, 75; malleable, lipped unions, 65.

COKE AND COAL.

Solvay Furnace Coke	\$5.25
Solvay Foundry Coke	6.50
Connellsville Furnace Coke	5.50
Connellsville Foundry Coke	6.00
Yough, Steam Lump Coal	3.83
Penn. Steam Lump Coal	3.63
Best Slack	2.95
All net ton f.o.b. Toronto.	

OLD MATERIAL.

	Tor'to.	Mont'l.
Copper, light	\$11 00	\$10 50
Copper, crucible	14 00	13 50

Copper, unere'bled, heavy	12 00	12 00
Copper wire, unere'bled..	12 00	12 00
No. 1 machine compos'n..	11 00	11 00
No. 1 comps'n turnings..	10 00	10 00
New brass clippings	9 00	9 00
No 1 brass turnings	7 50	7 50
Heavy lead	3 25	3 00
Tea lead	3 00	2 75
Serap zine	3 50	3 25
Dealers' purchasing prices.		

SMOOTH STEEL WIRE.

No. 6-9 gauge, \$2.35 base; No. 10 gauge, 6c extra; No. 11 gauge, 12 extra; No. 12 gauge, 20c extra; No. 13 gauge, 30c extra; No. 14 gauge, 40c extra; No. 15 gauge, 55c extra; No. 16 gauge, 70c extra. Add 60c for coppering and \$2 for tinning.

Extra net per 100 lb.—Spring wire; bright soft drawn, 15c; charcoal (extra quality), \$1.25.

METALS.

Prices in cents per pound:

	Mont'l.	Tor'to.
Lake copper	16.00	15.75
Electrolytic copper	16.00	15.75
Spelter	6.00	6.00

Lead	4.30	4.50
Tin	50.00	50.50
Antimony	10.00	9.75
Aluminum	23.00	23.00

SHEETS.

	Mont'l.	Tor'to.
Sheets, black, No. 28....	\$2 85	\$3 00
Canada plates, ordinary,		
52 sheets	2 80	3 00
Canada plates, all bright.	3 70	4 15
Apollo brand, 10 ³ / ₄ oz.		
(American)	4 30	4 20
Queen's Head, 28 B.W.G..	4 50
Fleur-de-Lis, 28 B.W.G..	4 20
Gorbal's Best Best, No. 28	4 45
Viking Metal, No. 28....	4 40

NAILS AND SPIKES.

Standard steel wire nails,		
base	\$2 40	
Cut nails	\$2 60	2 65
Miscellaneous wire nails..	75 per cent.	
Pressed spikes, 5/8 diam.,		
100 lbs.	2 85

FINE STEEL WIRE.

Discount 25 per cent. List of extras. In 100-lb. lots: No. 17, \$5; No. 18,

\$5.50; No. 19, \$6; No. 20, \$6.65; No. 21, \$7; No. 22, \$7.30; No. 23, \$7.65; No. 24, \$8; No. 25, \$9; No. 26, \$9.50; No. 27, \$10; No. 28, \$11; No. 29, \$12; No. 30, \$13; No. 31, \$14; No. 32, \$15; No. 33, \$16; No. 34, \$17. Extras net. Tinned wire, Nos. 17-25, \$2; Nos. 26-31, \$4; Nos. 30-34, \$6. Coppered, 75c; oiling, 10c.

MISCELLANEOUS.

	Cents
Putty, 100 lb drums	\$2.70
Red dry lead, 560 lb. casks, per	
cwt.	6.25
Glue, French medal, per lb	0.10
Glue, 100 flake	0.11
White lead, ground in oil, No. 1	
pure, 100 lbs.	8.40
Tarred slaters' paper, per roll...	0.95
Motor gasoline, single bbls., gal..	24 ¹ / ₂
Benzine, per gal.	23 ¹ / ₂
Pure turpentine	64
Linseed oil, raw	58
Linseed oil, boiled	61
Plaster of Paris, per bbl.	2.10
Plumbers' Oakum, per 100 lbs..	4.25
Pure Manila rope	17

The General Market Conditions and Tendencies

This section sets forth the views and observations of men qualified to judge the outlook and with whom we are in close touch through provincial correspondents.

Montreal, Que., April 7.—Things were rather quiet in the machinery trade last week, though most of the dealers had plenty to do following up good prospects. The Grand Trunk Railway Co. have just placed order for 15 locomotives of the Mikado type with the Montreal Locomotive Works, Longue Point, and for 25 of the same type with the Baldwin Locomotive Works, Philadelphia. Delivery is to commence in August next.

Pig Iron, Bar Iron, Etc.

There is but little change in the situation regarding these two products. Buyers have been holding off lately in this district, especially those located on the Great Lakes and along the St. Lawrence, since the opening of navigation will mean a reduction in freight averaging 10 cents per 100 lbs. Deliveries of all lines of steel products are extremely difficult to obtain under six months, and it will probably be the end of the year before conditions begin to get any easier. English pig iron is still being quoted at \$21.50 for delivery at the opening of navigation.

Copper and Other Metals.

At last, copper seems to have taken a turn for the better, the price in New

York last week having risen 40 cents per 100 lbs. Lead was also rising all week, and tin is up 1 cent per lb. This has resulted in a general livening up of the market, buyers showing a tendency to purchase freely in anticipation of a still further rise.

General Trade Conditions.

Trade is active in hardware, especially for building purposes, but, generally speaking, it is not increasing in proportion to that of other years, because settlements have been and continue unsatisfactory, especially in Quebec. Montreal realty market is active, several large properties having been sold last week. Indications are that a heavy building year is opening up. Both the East and West are now anxiously awaiting the opening of navigation at the head of the Great Lakes, and indications are that the first freighters will get away from Thunder Bay between the 21st and 25th of this month. The event will not only release 9,000,000 bushels of wheat now afloat in Thunder Bay and 12,000,000 bushels in store at Fort William and Port Arthur, but also unusually large quantities of mixed freight waiting to be moved at bay and lake ports.

Toronto, April 9.—Machinery dealers have not much to complain about this week. A nice steady business has been coming in, with no let-up for the last few days. There were no large lines—mostly orders for single or one or two machines. A. R. Williams & Co., Toronto, received instructions this week from the Northern Aluminum Co., Sterling Road, to ship all machinery ordered for their new plant. This is a branch of a Pittsburg concern, and their Toronto plant, which is just completed, is being equipped with the most modern machinery. The A. R. Williams Co. obtained a large share.

Pig Iron.

Canadian blast furnaces were not affected much by the recent floods. In the States the month of March would have shown a record output for pig iron and steel had not the floods shut down many of the most important furnaces. Those which were not put out of business were forced to bank, the water demoralizing the railway traffic, so that no coke could be moved. The market in Canada is quiet, no business being done in pig iron. This condition has prevailed for the past two weeks.

Steel.

In spite of the stringency of money, local manufacturers seem to be developing confidence, as they are now ordering steel from the mills instead of from warehouse, even in view of the extended

Concerning the Transmission of Power by Chain Drive

By H. T. Hildage

The writer of this paper expresses the opinion that the Transmission of Power by Chain Gearing is a matter which all engineers will be compelled to study closely in the near future, and indicates that the subject is one of immediate and special interest to electrical engineers and all who are concerned with the transmission of power from electric motors to machines or line shafts.

CHAIN gearing combines all the advantages of a positive and highly efficient drive with just as much elasticity as is desirable. It allows, also, almost complete freedom as to the position of the motor and its distance from the shaft or machine to be driven, which renders it specially useful and convenient. The connecting link between prime movers and line-shafts, and between line-shafts and machines, in the past has been very much neglected, and is not by any means adequately considered even yet. Steam engine builders, gas engine builders, and electrical engineers have all been striving their utmost to improve the efficiency of the machines they make, but the efficiency of the transmissions between the first mover and the machine to be driven are often the cause of more loss than all the rest of the plant put together. It follows, then, that a means of transmitting power from engine or motor to line-shaft or to machine that is quite positive, that will ensure from 96—98½ per cent. of the power given off by the motor being transmitted to the machine, and that imposes practically no restrictions as regards the relative positions of the motor and the machine, is one that demands earnest consideration.

Development.

Driving chains have been developed by a commercial house, and they owe their origin to the necessity for finding a suitable means of transmitting power from a bicycle crank-shaft to the road wheels. Chain gearing has never been submitted to, and has never received, the attention of independent scientific institutions or authorities, and consequently is not usually accepted as a standard means of transmitting power. Those who speak of it, therefore, and endeavour to impart knowledge concerning it, must necessarily take up more or less, the position of advocates, and in putting forward their claims must speak frequently of the disadvantages of other forms of gearing.

The foregoing, being definitely stated and accepted, it may be a good plan to summarise briefly the advantages of chain gearing.

A Positive Transmission.

(1)—It is a positive transmission, inasmuch as the chain cannot slip over the wheels as a belt does. It is elastic,

however, since the weight of the chain which hangs between the wheels may act as a spring; lubrication in the bearings, and in certain cases, even the shapes of the links themselves adding to this quality. The effect of this elasticity is to reduce considerably the vibration and noise which is inseparable from a positive power transmission such as spur gearing. It also has the effect of rendering unnecessary the microscopic accuracy of erection and alignment usually essential to produce high efficiency with tooth gearing of any type.

Highly Efficient.

(2)—It is highly efficient and the efficiency is maintained until it is completely worn out. Experiments have shown that the efficiency of a well-designed chain drive is somewhere between 96—98½ per cent. Tests were made recently, at Faraday House, on a motor car transmission (that of the S-10 Phoenix motor) consisting of two chain drives and a countershaft. The total loss of power in the two chain drives and the bearing of the countershaft was only 7 per cent. The nature of the action of the chain upon the wheel, as is explained in the description which follows, is such that the high efficiency is maintained until the chain is worn out.

Economical of Space and Light.

(3)—As compared with rope or belt drives, chain gearing is much more economical of space and light. The distance between shafts which is necessary for chain driving never exceeds 8 or 9 ft., and can, if the circumstances require it, be so small that the chain wheels very nearly touch one another. For this reason, it is even possible to take out a pair of spur wheels, replace them by chain wheels of smaller diameter, and get, as the result, a highly satisfactory drive as regards efficiency and absence of noise and vibration. For overhead factory and shop driving, chains and chain wheels are usually smaller in dimensions than the belts and pulleys which they replace, and as the shafts can be placed so much closer together, it follows that in a workshop dependent on overhead lighting, the interruption of light is very much less with chain-gearing than with belting. It even renders possible, in many cases, another form of drive—namely, the

placing of line-shafts under the floor, with short drives from line-shaft to machines. This has been taken advantage of in one or two engineering works and textile factories.

Electrical Driving.

(4)—In introducing electrical driving into existing factories, it is very often possible, by the use of chain gearing, to use faster running motors than is the case with belt or rope driving. In order to get ordinary efficient drives with belts and ropes, it is necessary to use quite large pulleys on the driven shafts, and these cannot always be accommodated. These driven pulleys become very large indeed, if the motor is fast-running, and the ratio of reduction a large one. With chain driving, a ratio of reduction of 6:1 can usually be accommodated with quite small wheels. An example of this was found in quetting for the electrification of a cotton mill in India a short time ago.

Two complete propositions were made:—One for chain driving with fast-running motors and the other for rope driving, using rope pulleys as large as could be accommodated, and motors for the corresponding speeds. Apart from the saving in space effected, the proposition including chain drives was much less expensive than the one including rope drives.

Heavy Incidental Economies.

(5)—There are heavy incidental economies effected by chain driving, partly on account of the advantages above mentioned, partly because it is not necessary that there should be any greater initial tension in the chain than such as is caused by its own weight, and partly on account of the more even turning that is obtained as the result of the drive being positive.

Chain Types.

The bush roller type and silent types, were described in detail by the author, who incidentally remarked that the term "silent" in this connection is merely a comparative one. Some silent chain drives are in truth as nearly silent as could be wished, but others, principally those where small pinions and very high speeds are used, are exceedingly noisy, giving off a loud buzz, which sometimes almost becomes a shriek. The wheel teeth and the chain

teeth on engagement and disengagement are moving at the same peripheral speed but differing angular velocities. The smaller the wheels, the greater will be the difference between the angular velocity of the wheel teeth and the chain, and it is this differing angular velocity that causes what slight impact there is, and is responsible for the noise mentioned.

In the course of further observations, the author remarked that it is better to use a chain of the poorest type than not to use a chain at all.

The Guiding Feature.

Silent chains are guided in three ways:

(a)—By flanging one of the wheels.

(b)—By a running flange in the chain which runs in a groove on the centre of the wheel.

(c)—By running flanges on the outside edges of the chain which overlap the edges of the wheel.

Perhaps the most generally satisfactory of these three methods, but certainly the most expensive, is the flanging of the wheels. Any end play in the shafts, or difficulty in aligning the wheels properly, can be allowed for by making the wheels extra wide, and faults in alignment or parallelism do not lead to such rapid destruction of the chain as is the case with other methods of guiding.

Comparison of Silent and Bush Roller Chains.

The silent chain is a much more delicate piece of mechanism than the bush roller chain, and must consequently be much more delicately handled. As a matter of fact, the bush roller chain is the chain that is always selected for difficult situations, hard service and rough usage, and under such conditions it is capable of doing wonderful work. The silent chain gives slightly smoother turning, runs much more quietly and can generally be used at higher speeds. It is the chain that is usually selected for use with electric motors, and for all cases where quiet and smooth running is necessary at moderate speeds.

The roller chain is generally used for low speeds, say up to about 600 ft. per minute. It is also used, however, when the speed is far outside the ordinary range. For example, it is the roller chain that is used for aeroplane work, where the linear speed often exceeds 2,000 ft. per minute. The objection to using a silent chain for such cases is its weight, which is undesirable in aeroplanes and airships, and also induces great centrifugal tension and loss of efficiency. The economical limit of speed for silent chains is about 1,300 ft. per minute. In special cases this may be exceeded with safety, but not with economy. A little calculation will readily

convince one that the tension in the chain increases more rapidly due to centrifugal force, than it diminishes on account of the increase of speed for transmitting a given power.

Silent Chain—Speed and Ratio.

For the silent chain, the speed should not exceed about 1,300 ft. per minute, and the pinion should always have at least 13 teeth, and if possible 17 teeth or 19 teeth. With a tooth angle of 60 degs., which is pretty generally adopted by chain manufacturers, it is possible to cut a pinion having as few as 13 teeth, and such a pinion can be used in extraordinary cases, but for economy, durability and quietness, 17 teeth or 19 teeth are much better.

The driven wheel should not, as a rule, have more than 100 teeth. There is no practical limit, of course, to the number of teeth that can be cut, but a little study will show that the power of the chain to adjust itself to a larger pitch circle, when its pitch has increased by wear, varies inversely with the number of teeth in the wheel:

Let (p) be the pitch of the chain, and (x) the increment of pitch after the chain has worn some time, and (θ) be the angle in degrees between two neighboring teeth on the wheel; then (θ) will

equal $\frac{360}{N}$ where N is the number of teeth.

If (h) be the distance between the position of the chain on the wheel teeth before it has worn, and afterwards, then (x) = h sin (θ) approximately.

The possible rise of the chain on the teeth depends on the depth of the tooth, and is nearly constant for all sizes of wheels of the same pitch. It follows that the maximum amount by which a chain may wear, and still remain in gear with the wheel, diminishes rapidly as (θ) diminishes, and consequently as the number of teeth in the wheel increases.

Roller Chain.

It has already been stated that the roller chain is most suitable for low speeds, that is to say, up to about 600 ft. per minute. It can be used on wheels having as few as 8 teeth, and as many as 80 teeth. It is more unsatisfactory to use a roller chain on small pinions at high speeds than to use a silent chain under these conditions, because not only is the roller chain noisier and more severely worn, but there is a decided impact at its entry upon the pinion, and if the pinion be small and the speed high, this impact may be sufficient to cause breakage of the rollers, which is fatal to the chain.

General.

It is very seldom, indeed, that a drive can be installed under conditions which

are ideal in every respect. One drive has a ratio which is rather larger than one would like; another is running at higher speeds; a third has an impulsive load, and in a fourth, perhaps, the shafts are closer together than they should be, and so it goes. If any drive, however, comes up, in which all limitations are exceeded, one has to consider whether it would not be better to find some other way out, or at any rate, one should balance carefully the advantages and disadvantages of different methods. It should be borne in mind always that the effect of ignoring or exceeding the limitations is not, as a rule, to make the drive a failure from the beginning, but to shorten the life of the chain.

Life of Drives.

This, unfortunately, is a subject upon which it is very difficult indeed to give any reliable information. Chain driving has only been in considerable use for a few years, and drives vary in so many points, each of which has its own effect upon the life of the chain, that so far it has not been possible to collect any satisfactory data. The author has under observation, however, a large number of drives, concerning which he is collecting such information as the angular motion that takes place at each chain joint, the bearing pressure on the pins, and the increase in pitch, and when these observations have been continued for a sufficient length of time, some data will be obtained that will make it possible to predict, with reasonable accuracy, the life of any given chain drive. In the meantime, since these three factors are the only ones that matter, it is always possible to make a comparison between any two drives.

The writer has found cases where chains, properly erected and well cared for in the matter of lubrication, have worn out in as short a space as two years, and others that have lasted as long as fourteen years. For example, there are a number of chain drives in the Guardian Printing Works, near Stockport, Manchester, which have been running for twelve years, and are still capable of further service. Some chain drives on the governor of a large steam engine were taken off the other day which had been running for fifteen years.

On the other hand, there were in the works of Messrs. Handiside, of Derby, a number of chain drives on punching and shearing machines which could not be made to last more than two years. As a general rule, the wheels will last about twice as long as the chain in a normal drive. The pinions or small wheels, up to about 25 teeth, are usually made of steel and case-hardened, and the larger wheels should be made from a good grade of hematite iron.

Once the general conditions of the drive are fixed, the only three factors that affect the life of the chain are alignment, adjustment and lubrication.

Motor Drives to Machines.

Individual drives from motors to machines are probably of more interest to machine tool makers and users than to any other class, although they are largely used for almost all classes of machinery.

A horizontal belt drive was replaced by a chain drive on a machine for drilling holes in railway sleepers. Before the chain was fitted, all kinds of belts were tried, and the most successful one seemed to be the type composed of small links of leather running on edge and fastened together by steel pins. After the conversion to chain drive, the machine turned out from 35 to 70 per cent. more work. This was mainly due to the saving of time which had been occasioned by having no belt to look after and repair. Considerable trouble had been experienced with heated bearings whilst the machine was belt driven, and this trouble was entirely eliminated.

A large amount of time which had previously been used in repairing the belt whilst the machine was out of service was entirely saved. The quality of the work was very much better, for the holes in the sleepers were found to be much smoother and rounder in the chain-driven machine than in the belt-driven machine.

The chain speed in this case was rather higher than 2,000 ft. per minute, and in designing the drives it was assumed that the belts were slipping 20 per cent. Experience confirmed the fact that this assumption was entirely justified.

Small Automatic Machine Drives.

In driving some small automatic machines in the works of Hans Renold, Ltd., it was found by measurement that the power absorbed by a chain-driven machine was 26 per cent. less than the power absorbed by a belt-driven machine, and that the wear and tear on the cutting tools was considerably less on chain-driven machines than on belt-driven machines. For instance, a circular parting-off tool was used in both cases, with a usable length of 8 in. In the belt-driven machine, two such tools were required for parting 2,485 rollers. They were ground nine times, and a length of 10½ in. was used. In the chain-driven machine a length of ½ in. only was used for 3,074 rollers, the tool only requiring grinding twice.

Similar economy was found in the drills. In 138 hours a chain-driven machine made 3,074 rollers in the same time that the belt-driven machine made 2,485, which represents an advantage of

23½ per cent. in favor of the chain-driven machine.

The work from the chain-driven machine was considerably better than that from the belt-driven machine, the machined faces showing a much smoother finish; this serves also as an explanation of the fact that the tools used on the belt-driven machine required grinding so much oftener than those used on the chain-driven machine. This test, and the others about to be described, were arranged, as far as possible, to be perfectly fair to both chain and belt.

Two No. 6 automatic gear cutters made by Brown & Sharpe were run on precisely the same kind of work—namely, cutting teeth in cast-iron wheels for 1¾ in. pitch silent chain; a cutting speed of 75 ft. per minute was used—one of the machines being chain-driven and the other belt-driven. On the belt-driven machine it was only possible to use a feed of 3¼ in. per minute; on the next higher feed the belt slipped and the machine jammed, and even at 3¼ in. per minute the belt whipped badly and rattled the overhead gear. On the chain-driven machine a feed of 5¼ in. per minute was easily maintained, showing an advantage in production of over 60 per cent. The increase in power necessary for higher production amounted to 10 per cent.

A further instance is that of a block drilling machine with two horizontal spindles which used to be driven by belt with chain feeds, and a maximum production of nine blocks per hour was permissible. This machine was converted to a chain drive, but the same speed of drill was maintained. After the conversion, it was found possible to obtain a production of 33 blocks per hour without difficulty. The work was of better quality, for the holes in the blocks were much more accurate to pitch on the chain-driven machine, than on a belt-driven machine.

Perhaps this last example is not absolutely fair, because the belt-driven machine had a chain feed, and when the belt slipped the feed being positive would be likely to assist in causing a jam. The experiment is therefore, being repeated with the feeds belt-driven, and some interesting figures will no doubt be obtained.

Positive Drive Feature.

It will be noticed that all these advantages have been obtained in comparison with belts, and the results constitute a very strong argument for a positive drive without necessarily strongly supporting the use of chain gearing in particular. It is the case, however, that almost the only positive drive that can safely and satisfactorily be used in such cases is a chain drive, because spur gearing imposes very

narrow limitations as regards centre distance, and in order to get anything like an acceptable efficiency, the gearing must be lined up with great accuracy; the slightest deviation causes noise, vibration and considerable loss of power, and may indeed occasion actual damage.

An example of this may be mentioned. A high-speed vertical engine was driving through a pair of helical wheels to a mill shaft taking about 250 h.p. Also driving on the same shaft was an old-fashioned beam engine, and the two engines were used alternately for driving the mill and also for driving a generator on the other side of the high-speed engine. One of the helical wheels, of course, was on the crank shaft of the engine, and the other on the line shaft, and there was no rigid connection between the two. Neither of them could be adjusted very finely, and as a consequence, the drive was never satisfactory. The wheel on the line shaft broke several times and considerable delay and damage was the result, and even while the drive was running, it was noisy and vibratory. A pair of 1¾ in. pitch chains, 10 in. wide, were substituted for the helical gears, and although the shafts were not quite parallel the drive is perfectly satisfactory, and has now been running for about 18 months.

Another example was that of some centrifugal pumps in the power station of the London Electric Railways at Lots Road, Chelsea. In this case the connected shafts were both vertical. Machine-cut helical gears and machine cut spur gears had both been used, but it was desired to replace them on account of the noise and vibration. A silent chain drive was put on, and horizontal guides provided to hold the chain up, and prevented it sagging between the wheels. The noise has been very much reduced, in fact, it is so slight as to be hardly possible to distinguish it from the hum of the motor. The power transmitted is 50 h.p.

It should be stated here that as a rule it is not possible to connect, by means of a chain, shafts that are vertical, being almost always necessary to provide some means of support for the chain between the wheels. Cases of this kind should therefore be approached with great caution.

Conclusions.

A good many of the examples given are subject to the comment that the belt, rope or spur transmission which was replaced was not a very good one, but the answer to this is that the vast majority of belt drives are not very good ones, and the power and money that is wasted on account of their use is incalculable.

Abstract of a paper read before the Rugby Engineering Society.

NEW COAL WASHING PLANT.

THE new coal washing plant of the Dominion Iron & Steel Co. is now completed, and will be in full operation when navigation opens. The construction of the new washer has been carried on jointly with the new No. 3 pier, which has also been completed, and is said to be the first of its kind in Canada. The washer, work on which commenced July, 1911, is 85 feet wide, 100 feet long and 150 feet high. The addition of this department brings the equipment of the Dominion Iron & Steel Co. on a par with that of the finest steel plants in the world.



COMPARATIVE COST OF THREE TYPES OF POWER PLANT.

AN interesting comparison of the cost of three different ways of providing an independent plant of 1,000 indicated horsepower for operating a variety of motor-driven machines, is given in a recent report by F. W. Dean, of Boston. The first plan considered was that of installing a 1,000-horsepower condensing Corliss engine, for which the costs were thus estimated:

Condensing Corliss Engine, 1,000 H.P.	
Engine and Condenser,	\$20,000
Foundations,	5,500
Electric Generators.....	12,000
Boilers,	7,500
Smoke Flue,	750
Chimney,	2,500
Heater,	1,000
Pumps,	500
Buildings,	20,000
Total Cost	\$69,750
Cost per I.H.P.	\$69.75
Fixed charges, 13 per cent of \$69.75	\$9.07
Attendance	3.21
Oil, waste and supplies20
	\$12.48

For coal used, including banking, the following estimate was made: assuming 310 days of 9 hours each, and 1.75 lbs. of coal per h.p.

$$1 \times 1.75 \times 9 \times 310 = 2,441 \text{ tons}$$

2,441 tons at \$2.75 (local price)	\$ 6.71
Add fixed charges, etc., as above	12.48

Total annual cost per I.H.P. \$19.19

This figure could be diminished to about \$18 per indicated horsepower year, by charging to the non-power uses of steam a proper proportion of the operating charges.

Gas Engines and Producers.

For gas engines and producers, the cost of plant on the indicated horse-

power basis was set at \$67.50; the figure being reached as follows:

Two hor. doub. acting gas engines	\$21,000
Two 300-kw. generators, 60 eye., 220 v.	6,600
Two 38½-kw. exciter sets ..	3,000
Two producers	7,700
	\$38,300
Add about 10 per cent. for freight and erection	3,800
	42,100
Foundations	1,100
	\$43,200
Add about 10 per cent. for contingencies	4,300
	\$47,500
Cost of buildings	20,000
	\$67,500

The cost of operating the plant was figured thus:

Fixed charges on plant, 14 per cent. of \$67.50	\$ 9.45
Attendance per I.H.P. per year	3.21
Oil, waste and supplies50
	\$13.16

To this is added the cost of coal, which was taken as 2 pounds per kw. hour including stand-by losses, equivalent to 1.28 pounds per indicated horsepower hour. The total coal for an indicated horse-power year would, therefore, be:

$$1 \times 1.28 \times 9 \times 310 = 1,786 \text{ tons}$$

2,000	
1,786 tons at \$2.25 (local price)	\$ 4.02
This added to \$13.16 gives the yearly cost of an indicated horsepower with gas engines as	\$17.18

Steam Turbines.

Approximate cost for a steam turbine plant were these:

Two 300-kw. steam turbines with condensers, at \$47 per kw.	\$28,200
Boilers, \$12 per kw.	7,200
Piping, flues, heaters, pumps, etc., at \$7	4,200
Foundations, at \$1	600
Chimney, at \$4	2,400
Buildings, at \$20	12,000
	\$54,600

Cost per kw.	\$90.00
Cost on I.H.P. basis	57.00

The conditions to be met by the three plants are not stated, although exercising an important influence often-times upon total costs.

EFFICIENT WORKSHOP LIGHTING.

IN a paper read before the American Institute of Electrical Engineers, Mr. C. L. Eshleman gives some figures showing the value of efficient workshop lighting. Regarding his personal experience as a workman, he found that his output on piecework when on night shift was only 55 per cent. of his output when working on the day shift on like work. Other mechanics noted, showed similar results. Further, among electrical field coils wound by the night shift, from 10 to 15 per cent. failed to pass the insulation test, whereas only 5 per cent. of those made by the day shift failed. Possibly lighting was not the only factor involved in these striking cases, and, may be, the illumination at night was unusually bad. Even allowing for these influences, the results indicate that efficient workshop lighting increases the output and improves the quality of the work done—two gains of great importance to employers and employed alike.



\$10,000,000 FOR BRIDGES.

IT is estimated that during last year about ten millions of dollars were spent by the C.P.R. bridge department on new and old structures, and a very large amount of bridge work is still in progress and proposed, exclusive of the extensive constructions that will be required soon for the proposed abolition of grade crossings. The magnitude of the bridge work is indicated by the following summary taken from the report of Mr. P. B. Motley for the year ended June 30, 1912:

At the end of the fiscal year, there were in existence 3771 bridges and open culverts. These had an aggregate length of 68.69 miles. There were 25,125 culverts other than open, of which 14,032 were permanent and 11,093 of a temporary nature. During the year, 778 old bridges and open culverts were replaced, aggregating 39,402 lineal feet, including 24 old iron and steel bridges, too light for present traffic and having a total length of 2438 feet. There were 923 culverts other than open and overhead bridges replaced. New bridges to the number of 109, aggregating 2.3 miles were added. The number of temporary bridges were reduced during the year by 629.



NATIONAL STEEL CAR CO.

The National Steel Car Co., plant at Hamilton, Ont., is now practically completed and 10 cars a day are being turned out. The full capacity of the plant is 30 cars a day which total it is hoped will be reached shortly. The plant has been in operation since December last and the profits have been at a rate sufficient to pay preferred dividends.

A Brief Statistical Review of Steam Boiler Explosions

By R. N. Blackburn, Wh. Sch.*

The writer of this paper makes no attempt to deal with details of steam boiler design or construction, his purpose being rather to review briefly such statistics of boiler explosions as are available, with the idea of giving the data more publicity, and securing for it more consideration than appearances would indicate it to be at present receiving.

NO official statistics are available of the number of boiler explosions in Canada, and I have not been able to obtain sufficient information to justify me in making even a rough estimate of them. Excepting in the Western Provinces of Canada where provincial inspection laws are in force, the importance of the proper supervision of steam boilers does not appear to be sufficiently realized. No records appear to be kept of the number of boiler accidents in Eastern Canada, and we can only form an idea of their probable number by a comparison with the U.S., over the greater portion of which similar conditions exist. In the United States, with the exception of the States of Massachusetts, Minnesota, Ohio, Pennsylvania, Tennessee and Montana, together with a few of the larger cities, there is no compulsory inspection of steam boilers. There are, however, a number of Boiler Insurance Companies who collectively supervise and inspect a very large number of boilers, and whose operations must have a beneficial effect in reducing the number of boiler explosions.

One of these, the Hartford Insurance Company, has for a number of years kept a record of such boiler accidents as have come to their knowledge. This company, with agents in most of the States of the Union, is no doubt very favorably situated for obtaining information, but it may reasonably be supposed that many comparatively slight accidents must occur which do not come to their knowledge and which, if recorded, would considerably increase the total number. In instituting a comparison between the number of boiler explosions in different countries, diverse legal definitions of what is involved in the word "boiler," present more or less difficulty.

Comparison Between Different Countries

The definition of the term "Boiler" in the Boiler Explosion Acts of 1882 and 1890 of the United Kingdom is a very wide one, and covers not only all classes of steam boilers, but also embraces heating systems, steaming kettles, drying cylinders, boiling pans, kiers, steam ovens and piping. No definition is given in the Act of the term "explosion," but the interpretation given in practice is very wide and is held to include such

minor accidents as the blowing out of a manhole jointing ring, the fracture of a valve cover and the blowing out of a rivet, and it has even been held to cover the bursting of a coffee urn in a restaurant. The latest report issued by the British Board of Trade gives the total number of boiler explosions in the United Kingdom for the twelve months ending June 30, 1911, as one hundred.

An analysis of the report shows that 65 of the above were explosions of steam ovens, heating pans, digesters, steam valves, traps and piping, which cannot be classed as steam boilers in the usual meaning of the term, and of the remaining thirty-five explosions, at least four of them are so trivial that they cannot properly be classed as explosions.

In comparing the number of boiler accidents in different countries it is evidently necessary to place the statistics on a uniform basis, and in preparing the following tables, this has been done as far as possible by restricting the meaning of the term "boiler explosions" to the commonly accepted meaning. On this basis, the number of boiler explosions for the last ten years for which particulars are to hand are as follows:

United Kingdom.		
Years.	Explosions	Persons Killed
1901-2	17	8
1902-3	16	14
1903-4	23	10
1904-5	17	5
1905-6	17	14
1906-7	16	8
1907-8	18	13
1908-9	35	12
1909-10	24	9
1910-11	31	3
Total	214	96
Average per annum	21.4	9.6

France.

Accidents per 10,000 pieces of apparatus.

Years	Explosions	Persons killed	Persons injured
1890-94	3.0	1.8	1.6
1895-99	3.2	1.9	2.0
1900-04	2.3	1.5	2.2
1905-09	1.8	1.2	1.4

Boiler accidents for the years 1908 and 1909—the only years for which I have the actual numbers, are:—

Years	Explosions	Persons killed	Persons injured
1908	28	13	41
1909	29	15	26
Average per annum	28.5	14	33.5

Germany.

Year	Explosions	Persons killed	Persons injured	Total killed and injured
1898	18	3	28	31
1899	14	13	22	35
1900	13	6	18	24
1901	17	10	17	27
1902	17	7	17	24
1903	10	6	5	11
1904	15	5	13	18
1905	9	4	5	9
1906	15	5	3	8
1907	16	7	9	16
Total	144	66	137	203
Average per annum	14.4	6.6	13.7	20.3

United States.

Years	Explosions	Persons killed	Persons injured	Total killed and injured
1901	423	312	646	958
1902	391	304	529	833
1903	383	293	522	815
1904	391	220	394	614
1905	450	383	585	968
1906	431	235	467	702
1907	471	300	420	720
1908	470	281	531	812
1909	550	227	422	849
1910	533	280	506	786
Total	4493	2835	5022	7857
Average per annum	449.3	283.5	502.2	785.7

Annual Average During 10 Years.

Country	Explosions	Persons killed	Persons injured	Total killed and injured
U. Kingdom	21.4	9.6	13.7	20.3
Germany	14.4	6.6	13.7	20.3
France**	28.5	14.0	33.5	47.5
U. States	449.3	283.5	502.2	785.7

**Average two years only.

Number of Steam Boilers.

The figures for the United States are to say the least, somewhat startling, and

*Chief Inspector of Steam Boilers, Province of Saskatchewan.

although there are probably more boilers in operation in the United States than in any of the other countries mentioned, the difference in the number of boilers is not sufficient to account for the increased number of boiler accidents.* The number of boilers in the United States was estimated in 1900 at from 150,000 to 200,000, these figures being taken from evidence given before the Select Committee of the House of Commons in that year. The number of steam boilers in France is probably about 150,000.

No records are available of the number of steam boilers in the United States, but it may reasonably be assumed that the number of boilers in each of the above countries is approximately proportionate to its population. The respective populations in round numbers are as follows:—

United Kingdom	42 millions
France	39 "
Germany	60 "
United States	76 "

Remembering that the United Kingdom is essentially a manufacturing country, it may confidently be assumed that the number of steam boilers in the United States is less than twice as great as the number of steam boilers in the United Kingdom, and when we consider that the number of boiler explosions in the United States is over twenty times as great as in the United Kingdom, and nearly seven times as great as in the United Kingdom, France and Germany combined, it is evident that no reasonable difference in the estimate of the number of boilers in the respective countries is adequate to account for the difference in the number of boiler accidents. A comparison of the number of persons annually killed is even more unfavorable to the United States, the number of persons annually killed by boiler explosions being nearly thirty times as great as in the United Kingdom and over nine times as great as in the United Kingdom, France and Germany combined.

There are no records of the number of boiler explosions in Canada but it is to be feared that, excepting in the Western Provinces where steam boilers are regularly and systematically inspected, the percentage of steam boiler explosions is nearer the standard of the United States than that of Europe.

Types of Boiler Not Accountable.

I do not think that the great difference in the number of boiler explosions in the United States and Europe can be accounted for by the difference in the standard types of boilers used. Exper-

ience shows that no type of boiler is free from accident, and although some types of boiler are, no doubt, more liable to explosion than others, the difference in this respect is not so great as is sometimes supposed. It was at one time claimed that the water tube boiler had solved the problem of making a practically non-explosive boiler, but experience shows that the percentage of accidents to water tube boilers is not materially less than in the case of other boilers of good design and construction. The explosion of water tube boilers at Milwaukee in 1909 and St. Louis in 1903, show also that the explosion of a water tube boiler can also be as disastrous as that of the ordinary fire tube type of boiler. In the latter case, the whole range of seven water tube boilers



R. N. BLACKBURN, Wh., Sch.

exploded, killing 8 and injuring 21 persons, and in the former case, 4 water tube boilers exploded, killing 1 person and injuring one person, besides causing damage estimated by the owners at \$114,000.

Supervision and Inspection Feature.

The relatively enormous number of explosions in the United States is rather to be attributed to the lack of proper supervision and inspection. This is clearly shown by the records of such States and cities as have laws enforcing efficient inspection of steam boilers. In the State of Massachusetts, it is claimed that the number of boiler explosions is less than .002 per cent. of the number of boilers in operation. In Montana, where State inspection laws are in force, no boiler explosion occurred last year.

It is difficult to imagine what the number of Boiler Explosions in the United States might be, but for the operations of Boiler Insurance Companies and the municipal inspection of many of the larger cities, the ignorance and reckless-

ness of some steam users being almost incredible. Many instances might be given, but two will suffice.

Ignorance and "Recklessness."

Until a short time ago, a boiler was located under a sidewalk in Woodward Avenue, in the fashionable shopping district of Detroit. Compulsory inspection laws made it possible to seek out this boiler for examination, and the first tap of the inspectors hammer punctured the plate like cardboard. Thousands of people had passed daily over this subterranean mine for years without knowing anything of their danger.

A Lancashire boiler was found to have a fracture at the root of the angle iron securing the front head to the boiler shell. Repeated caulking proving ineffectual to stop the leakage, a wood strut was wedged between the boiler head and the brick wall of the boiler house. As the fracture gradually extended circumferentially around the boiler, the resourceful owner added more props until finally the boiler exploded carrying all before it, including the owner, a victim of his misplaced ingenuity.

The Attendant Not Always to Blame

It was at one time the practice to attribute nearly all boiler explosions to the ignorance or carelessness of the engineer in charge, the immediate cause of the explosion being usually attributed to low water. This practice still survives, and as the engineer is frequently killed and unable to exonerate himself, the verdict generally goes unchallenged. A letter from a Canadian manufacturer was shown to me only a few days ago in which it was contended that at least ninety-nine per cent. of boiler explosions were caused either by low water or by the engineer not keeping his boiler clean, his argument being that regulations governing the design and construction were unnecessary.

The result, however, of a number of careful enquiries shows that many explosions cannot be attributed to these causes, and various fanciful and elaborate theories have been advanced to account for boiler explosions which could not be accounted for on the "low water" or "scale" hypotheses. Some of these theories may be briefly mentioned:—

Electricity Theory.

Electricity is supposed to be generated by friction of the water on the boiler plates, or by the rush of steam through the main steam outlet, but it does not seem very apparent, however, why electricity, even at a high potential, should cause the boiler to explode.

Spheroidal Conditions of the Water.

If a drop of water is thrown on to a very hot plate, it immediately assumes

*The number of boiler accidents per annum in the United States is estimated by the Superintendent of the Fidelity and Casualty Co. of New York at between 1,300 and 1,400, of which 300 to 400 are violent explosions.

the spheroidal condition, and the globules are prevented from coming into actual contact with the hot plate by a cushion of steam which surrounds them. As the plate cools, the water loses its spheroidal form and the globules spread out and are immediately evaporated into steam. In the case of a boiler, it was supposed that under certain circumstances the water assumed a spheroidal condition and under a slight reduction of temperature caused for example by damping the fire, the water would leave its spheroidal state and coming into contact with the heated plates would generate steam in such large quantities that the safety valve could not carry it off; as a consequence, the boiler would explode from over pressure. This theory is undoubtedly very ingenious, but the matter-of-fact boiler inspector of the present day would merely argue that the safety valve was too small for the boiler.

The Oxy-Hydrogen Gas Theory.

It was supposed that at the high temperatures of the furnace, water was decomposed into its constituent gases, oxygen and hydrogen, which afterwards re-united to form steam. This re-union is accompanied as every student of chemistry knows, by a violent explosion. The theory has not been proved, however, and though numerous attempts have been made to reproduce the supposed conditions experimentally, they have not been attended with success.

The Hydrogen Gas Theory.

It is well known that steam coming in contact with red hot iron is decomposed, the oxygen uniting with the iron to form magnetic oxide of iron and the hydrogen being set free. The amount of hydrogen which might be thus liberated in a steam boiler is, however, very little, and as it could not explode except in the presence of free oxygen, it is not probable that any boiler has ever exploded from this cause.

Water Purged of Air.

When the air has been driven out of water and the latter is quiescent, it has been shown that the water may be heated considerably above the normal boiling point before being evaporated into steam. It is said that water has been heated in this manner as much as fifty degrees Fahrenheit above the boiling point before boiling actually commences. When boiling once commences, the excess heat immediately converts a considerable portion of the water into steam and an explosion follows. While a boiler explosion from this cause is perhaps not impossible, it does not appear likely to occur except under very exceptional conditions, and most boiler explosions can be readily accounted for without in-

voking the aid of either this or any of the above theories. No doubt the extreme violence of some boiler explosions led engineers to seek some explanation along the lines of a sublimation which alone appeared sufficiently violent to account for the devastation which sometimes occurs when a boiler explodes.

Lancashire Boiler Explosion.

The accompanying diagram represents the development of the shell of a Lancashire boiler which exploded at Dislington, England, on the 18th day of September, 1909. The force of the explosion ruptured the boiler into a large number of pieces. Fifty of the larger of these were recovered and pieced together. The lines of rupture are indicated in the diagram by heavy lines. The

and the excess heat causes the immediate generation of an immense number of minute bubbles of steam throughout the whole body of water in the boiler. This causes an extremely rapid and violent expansion of the water which is projected with enormous velocity over the whole interior of the boiler. The momentum of a large mass of water in such rapid motion is almost irresistible and the boiler is shattered and the pieces hurled in all directions. The energy thus developed is very great.

Stored-Up Energy.

Professor Thurston states that a cubic foot of heated water under a pressure of 60 or 70 pounds per square inch has about the same energy as a pound of gunpowder.

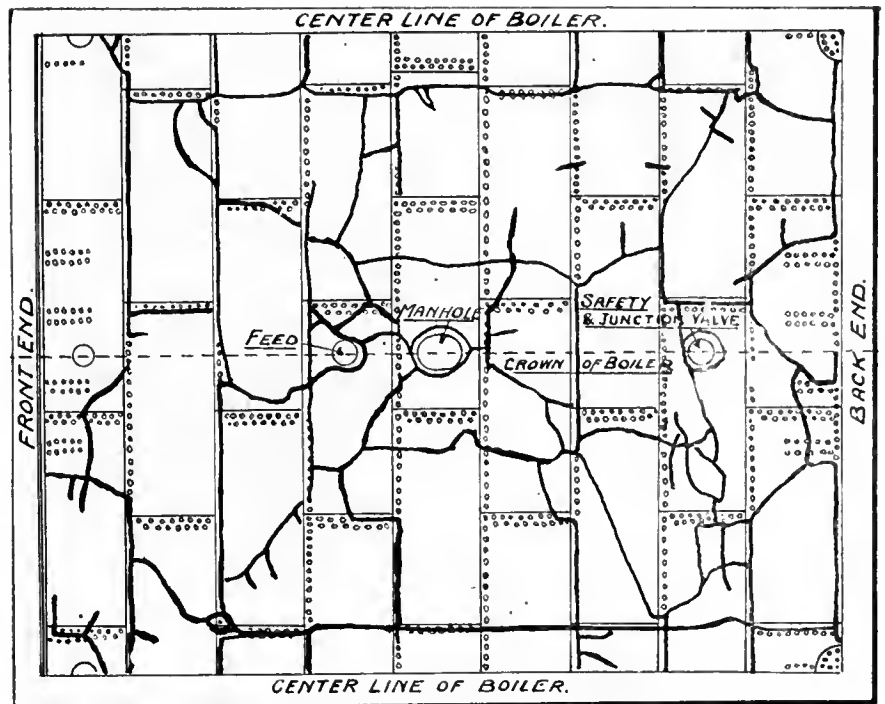

DEVELOPMENT OF THE SHELL OF AN EXPLODED LANCASHIRE BOILER, SHOWING THE LINES OF RUPTURE.

effect particularly when the ductility and tenacity of boiler plate is considered, appears rather as if the boiler had been ruptured by the detonation of some explosive than a mere giving way under a static pressure.

Cause of the Widespread Rupture.

What actually occurs when a boiler explodes in this manner appears to be as follows:

The boiling point of water varies with the pressure, and while water at atmospheric pressure boils at 212 degrees Fahr., at a pressure of say 150 lbs. per square inch, the boiling point is raised to about 366 degrees Fahrenheit. When a boiler ruptures under steam pressure, the temperature of the water, if the rupture is large, falls almost instantaneously to a temperature of 212 degrees

The energy in foot pounds stored up in one pound weight of heated water at a temperature of T degrees Fahrenheit is expressed by the formulae:

$$W=778 T-(212+673 \text{ Hyp. log } \frac{T+461}{673})$$

The weight of a 72-inch x 18 ft. horizontal return tubular boiler is about 20,000 pounds. The weight of water contained at the normal working level is about 17,000 pounds, and the weight of steam, at 150 pounds gauge pressure is about 45 pounds. The energy stored up in the heated water is therefore 198,390,000 foot pounds and in the steam, 1,635,637 foot pounds. The total energy liberated when the boiler exploded is, therefore, over 200,000,000 foot pounds, sufficient to raise it to a height of about 10,000 feet, or nearly two miles.

Fortunately the energy stored up in a ruptured boiler is usually dissipated more gradually, and it is but seldom that the conditions are such as to release this large amount of stored energy instantaneously, yet the effects of a boiler explosion are sufficiently serious, and when a boiler in fairly good condition bursts from over pressure, the consequences are usually disastrous.

Causes of Boiler Explosions.

The immediate causes of 1079 boiler explosions have been tabulated by Mr. B. H. Thwaite and were given by him in a lecture before the Yorkshire College Textile Society, as follows:

External corrosion	152
Overheating	133
Over-pressure	118
Weakness of Flue	106
Fracture	80
Internal corrosion	72
General deterioration	58
Defective stays	54
Malconstruction	51
Grooving	31
Deposit	27
Weak manhole	23
Bad material	11
Absence of safety valve	7
Cause not ascertained	156

—
1,079

It may be pointed out that explosions under at least seven of the above headings may, in most cases, be ascribed to faulty design and construction, and some of the explosions under the other headings are sometimes traceable to the same cause. For example, boilers are frequently constructed, which, owing to insufficient mudports, are almost impossible to keep clear of deposit, or to ascertain the condition of the boiler internally. Faults in design are constantly being brought to my notice, and the importance of proper supervision of the design and construction of steam boilers can scarcely be over-estimated.

It should also be noted that the majority of purchasers of steam boilers have little or no knowledge of the principles underlying their design and construction and are not able to judge for themselves as to the respective merits of different boilers offered. Manufacturers, again, who, for their own reputation, would prefer to furnish boilers of a high standard, may have to meet the competition of others who offer boilers at a lower cost, made of poor materials, together with bad workmanship, and oftentimes defective design.

Overloading Steam Boilers.

It appears to be an almost invariable rule that the load on steam plants shall be gradually increased until the capacity of the boilers is taxed to the limit. In

a factory, as the business extends, new machines are added; in a municipal plant, as population increases, the load is increased until the plant is over-loaded and something must be done to increase the power of the engine. Obviously, the easiest and quickest method is to raise the boiler pressure, and where the boiler pressure is not limited by inspection laws this method of increasing the power is usually adopted. The boiler has probably been running for years at the pressure for which it was originally constructed, and the increase comes at a time when, in the ordinary course of events, the pressure should rather be reduced on account of depreciation, due to wear and tear.

Where the maximum pressure allowed to be carried is limited by inspection laws, the speed of the engine may be increased or an additional engine installed and supplied by the same boiler or battery of boilers, the latter being forced to supply the required steam. This leads to overheating and greatly increased wear and tear, and the plant being short of boiler power, a boiler cannot be laid off for cleaning without a partial stoppage of the factory. Scale is allowed to accumulate, and the stresses set up by the consequent overheating of the plates or by the undue forcing, develop faults in the structure and too frequently ends in adding another accident to the already long list of boiler explosions.

Boiler Inspection in Saskatchewan.

The first Act providing for the compulsory inspection of steam boilers in the Province of Saskatchewan was passed in 1898. New Acts were passed in 1901 and 1906, and the Act of 1906, with amendments made in 1908 and 1909 is still in force. The Acts have operated very successfully and the almost complete immunity of the Province from boiler explosions testifies to their efficiency. As many boilers in the Province were, however, found to be of faulty design and construction, it was soon realized that an adequate system of inspection should commence with the supervision of design and construction, alike in the interests of public safety and also for the protection of the purchaser.

Provincial Conference.

After some correspondence with neighboring provinces, a conference was held at Regina in December, 1909, which was attended by representatives of the Governments of British Columbia, Alberta, Saskatchewan, Manitoba and Ontario, and by a representative of the Canadian Manufacturers' Association. At this conference, regulations were drawn up governing the construction of steam boilers and providing for the examination and registration of designs which have since been adopted by the Govern-

ment of Alberta and Saskatchewan. Regulations of a similar kind have been in force in British Columbia since 1902. The Provinces of Manitoba and Ontario have not yet adopted regulations, but I have been given to understand that the Province of Ontario will probably adopt them in the near future and the Province of Manitoba will soon follow.

Saskatchewan Province Regulations.

The superiority of boilers built to the Saskatchewan regulations is becoming recognized outside our own province and I understand that there is a considerable demand in the United States for boilers built to Western Canada regulations. This is particularly the case with agricultural machinery and I have been informed by the representative of one of the largest makers of this class of product in the United States, that they are now building all their boilers to comply with the Western Canada regulations.

The regulations have been in force in Saskatchewan since January, 1911, and in Alberta since January, 1910, and have produced a marked improvement in the design and workmanship of boilers coming into the province.

Before commencing work on any boiler, the manufacturer is required to submit to the Department of Public Works, blue prints and specifications for approval. When the design is approved, it is registered, and the manufacturer is notified as to the working pressure the boiler will be allowed to carry. He is thus in a position to guarantee to the purchaser that the boiler has been approved for a given working pressure. After registration of the design, the manufacturer may build any number of boilers to that design without further registration of drawings. Further, the manufacturer is required to furnish the purchaser with an affidavit that the boiler has been built in accordance with the design and specification which has been registered and approved by the Department of Public Works. The affidavit, also certifies that all material used in the construction of the boiler is of the standard required by the regulations, that the workmanship is in accordance with the Department's requirements, and that the boiler has been properly tested before being sent out of the manufacturer's workshop. This method of procedure considerably simplifies matters for the manufacturer. Full particulars of approved designs, giving the dimensions and ratings of the various parts of the boiler are given to each inspector so that an efficient check is maintained by the Department on each boiler shipped into the province.

Up to the present time 314 designs of steam boilers and 238 designs of steam fittings have been approved and registered by the Dept. of Public Works.

Formation and Organization of a Large Mfg. Corporation*

By C. B. Auel**

The substance of this article formed the first of a series of lectures on Works Management, delivered at the Westinghouse Club. The lecturers were, in each case, experts on the particular subjects, and the intention was that the various features of works management should be plainly and interestingly stated, more especially as the audience was composed of a group of comparatively young men.

IT is assumed that a number of men, either capitalists themselves or controlling capital, have met together and decided to form an organization for the manufacture and sale of some mechanical apparatus, believing, of course, that in so doing profit may be made. The only reason any business concern has for its existence is to make profit for its stock-holders; and, the greater the risk, the greater should be the ultimate returns, if the venture prove successful. For any manufacturing concern to be successful, certain fundamental conditions must be met, principal among which may be mentioned the following:

1—There must be a market for the sale of the goods which it is proposed to manufacture.

2—There must be a market in which to purchase the necessary raw materials and supplies.

3—There must be suitable transportation facilities for the raw materials and supplies, as well as for the completed apparatus; these two, though usually the same, are occasionally quite different.

4—There must be labor available with which to manufacture.

5—There must be capital with which to purchase labor, materials and supplies.

All these points require the most careful consideration; in addition, climate is sometimes a most important factor. The tendency has been for a manufacturing plant to locate near the source of raw materials; for example, iron and steel mills near the coal or iron supply; flour mills adjacent to the wheat fields; cotton mills in the midst of cotton fields, especially since an artificially moist atmosphere can now be created in the mills; fish canning industries on the river banks or ocean shores. However, with cheaper transportation and cheaper electric power costs, this tendency to seek the raw material field is not quite so important, and other considerations may outweigh it, such as the vicinity either of the labor market or of the market for the disposal of the finished product. Take Pittsburgh and the steel industry—though the best loca-

tion up to the present, the indications are, that with the upbuilding of the West, a better location in the near future would be in the vicinity of Chicago, because the labor market is as good, the increased haul of coke is balanced by the decreased haul on ore, and the average haul on the finished product would be considerably less.

Corporation, Not Partnership.

Since it has already been assumed that an organization is to be formed, it is quite evident that the men who are willing to risk their money in the enterprise have canvassed the situation and feel convinced that all of the conditions stated can be fulfilled. It is now further assumed that the new organization will be a corporation and not a partnership. The advantages of one over the other are in part as follows: A corporation is a separate thing, quite apart from many of the individuals belonging to or composing it; its functions are not necessarily disturbed either by the death or withdrawal of any individual, whereas a partnership is usually terminated thereby. It invariably has a charter which gives it legal standing, while in a partnership the agreement may be implied, not written, and may even exist without the knowledge of some of its members; in a corporation the individuals cannot as a rule be called upon to assume any of its debts, but in a partnership each member may be held responsible for all of the debts. A corporation's shares can be sold, transferred or loaned by the individual owners; in a partnership, no money can be borrowed on the strength of a member's interest. The management of a corporation is vested in a board of directors with limited powers, who must make periodic reports to its stockholders; in a partnership each partner may act with unlimited powers and without the consent or knowledge of the other partners.

Incorporation Features.

A name is now selected for the corporation, plans are drawn up, outlining its scope as regards capital stock, incorporators, lines of manufacture, duration of charter, location, etc., and a State charter is applied for, the application being filed with the Secretary of State. At least three persons, and in

some cases five or more, are required to form a corporation. The statutes of the various countries, in order to expedite business, now provide for the formation or incorporation of stock companies or corporations, as they are more commonly called, though formerly they were required to be authorized by direct act of legislature.

A license, not a charter, is next issued, authorizing books to be opened for subscriptions to the capital stock. A certain minimum amount is usually required to be subscribed and paid for, a meeting of subscribers held, directors elected, by-laws made and a record of all these proceedings filed with the Secretary of State, before a charter is granted authorizing the transaction of business.

Corporation Officers.

Upon the granting of the charter and the completion of other equally important arrangements which it is not requisite to detail here, the corporation is ready to organize on more permanent lines. The first officers are usually selected from among the men who first contribute toward the capital stock, and who are naturally therefore, the original stock-holders, though occasionally, when temporarily desired not to disclose the identity of the real promoters, dummy officers may be installed. At the proper time, these dummies resign one after another, the real officers then being appointed, usually by the board of directors, to fill the vacancies. At this time also a new board of directors may be elected. The members of the board are not elected permanently, but usually for stated periods, though all of them may stand for re-election. It is not necessary for the members of the board to own personally all, or even a majority of the stock; but, where such is not the case, they must at least control its voting power.

The executive officers consist of the chairman of the board of directors, who is invariably the ranking officer; the president, one or more vice-presidents, the secretary, the treasurer and the auditor; but it does not follow that (the chairman excepted) they are necessarily members of the board, though frequently some of them are. In certain concerns, there may also be an executive committee reporting to the chairman.

*From an article by the author in the Sibley Journal of Engineering.

**Director of Standards, Processes and Materials, the Westinghouse Electric & Mfg. Co.

The officers in turn choose the departmental heads, including the managers of sales, engineering, works, etc., and these in turn complete their respective departments.

Although the proceeding has been rapidly outlined, it does not follow that the officers named are all chosen at one time, nor need they be separate and distinct. The president may perhaps be manager of one or more departments as well, the treasurer may combine with his work the duties of secretary, the auditing department may consist of but a bookkeeper, and so on.

Increase of Capital Stock.

With the growth of its business, a corporation sometimes finds it advisable to increase its capital stock; and this is accomplished, either by the issue of additional shares of the same kind as the original, or by creating a new kind, in which case the original is generally called preferred or first preferred, and the second, common or second preferred. Sometimes, rather than increase the capital stock, mortgages, occasionally designated as debentures or bonds, may be issued with a part or the whole of the plant as security. Of course, any move of this kind to raise money must receive the sanction of the stockholders before it can be put into effect. Of the two methods, the latter, that is the issuing of mortgages or bonds, is perhaps to be preferred, for the reason that the debt is sooner or later wiped out, when the interest which it has been necessary to pay during the life of the mortgages or the bonds can be applied in other ways; whereas, the payment of interest on stock is a perpetual obligation even though a concern be not always successful in meeting it. The money thus raised by a corporation may be used for the erection and equipment of additional buildings, the further purchase of machinery or of the patents and good will of another manufacturing concern. It may be used for the cancelling of outstanding obligations, such as the payment of maturing notes and bonds, or it may be used in various other ways.

Stockholders Supreme.

From what has thus far been told, it will be inferred that the stockholders are the ultimate authority in every corporation. The board of directors is elected by them, except possibly at its formation; and, accordingly, must inform them regularly as to the conduct of the business. This is usually done through the medium of annual, semi-annual or quarterly reports, which give in a very complete, yet condensed form, certain essential information, such as a statement of the work undertaken and accomplished, as well as an outline of

prospective business and new fields of activity. The assets, liabilities, income, profit and loss, are also set forth. If these statements are not considered satisfactory by the stockholders, it is within their power, by voting their disapproval at one of the stockholders' meetings, to change the board of directors, or to make any other changes they may deem necessary or desirable. In voting, each share of a kind usually counts one vote. It is not a question of individuals, but of votes; in other words, a single stockholder, by possessing or controlling a majority of shares, may dictate the policy of the corporation.

Directors' Reports to Stockholders.

The principal features of the reports made by the directors to the stockholders are, in large measure, compiled from regular monthly statements issued by the various departmental heads to the executive officers. Most of the financial information contained in them is obtained through the medium of the accounting department, under whose charge are placed practically all of the financial accounts. Where such is not the case, they at least exercise supervision over the methods employed.

hand column giving the assets, the right hand the liabilities.

Taking the assets first, these may be divided into several groups—Property and plant, quick assets, working assets, investments, miscellaneous; each in turn being further divided into various items. Included in property and plant are the grounds on which the works are located, as well as any other property of a like nature which the corporation may hold; also, the buildings occupying these grounds and the machinery or other equipment which may be either on the ground or within the building.

Quick assets mean exactly what the term implies, either money itself or available assets, which, if occasion makes necessary, may be converted into money quickly. These, therefore, consist of accounts and notes receivable, representing either customers' accounts that have not been paid, or for which interest bearing notes have been given, and which may, therefore, be readily discounted at a bank or other medium of exchange; also interest due from cash in bank or from other sources, and finally, cash in bank or on hand.

Sample Balance Sheet.

ASSETS.	LIABILITIES
Property and Plant.	Capital Stock
Real estate, Buildings, Machinery, Equipment.	Preferred, Common.
Quick Assets.	Current Liabilities
Accounts receivable, Notes receivable, Interest accrued, Cash.	Accounts payable, Notes payable, Interest accrued, Taxes (accrued but not due).
Working Assets.	Funded Debt
Raw materials, Work in progress (in factory and in course of erection at destination). Finished stock and apparatus.	Bonds, Mortgages.
Investments	Miscellaneous
Bonds (in other companies), Stocks (in other companies).	Adjustment Reserves.
Miscellaneous.	Profit and Loss
Charter, Patents, Furniture, Fixtures, Taxes (paid in advance), Insurance (paid in advance).	Surplus

It will be advisable now to examine into the several statements just referred to, as being submitted by the directors to the stockholders, in order to see how they are made up, and in so doing to learn a little more in detail of the methods of any large corporation. Every concern not only extends, but it receives credit; in other words, it owns as well as owes. Were this not so, the business of the world would be very much restricted. What a concern owns is called its assets, what it owes is called its liabilities. Discussing the assets and liabilities, which appear on what is known as a balance sheet, it may be seen that it is issued in ledger shape, the left

Under the head of working assets, sometimes known as trading assets, are placed raw materials, work in progress consisting of apparatus in course of completion in the works or at destination, and finished stock and apparatus. In the line of investments may be mentioned bonds and stock in other companies—these are acquired sometimes by purchase, sometimes in part payment for apparatus furnished.

The items grouped under the head of miscellaneous—namely, charter, patents, furniture, fixtures, taxes and insurance, are sufficiently plain without explanation—taxes and insurance are only included when paid in advance. Attention

is especially called to the two items, charter and patents, which occasionally are the very life of a concern and which may, therefore, be set down sometimes in large figures.

Balance Sheet Liabilities.

Turning next to the liabilities, the very first item, and usually, though not always, the largest, is the capital stock. This is a liability because of the shares having been sold to the stockholders. Under current liabilities come such items as accounts and notes payable, interest due on same, taxes and insurance—the last items included only when accrued, but not yet due or paid. The next liability is that of funded debt, meaning a secured debt; for example, money raised by bonds and mortgages and pledging the property or plant as security. The item under miscellaneous called reserves is an amount set aside to cover certain kinds of depreciation, like bad debts or the loss on material or stock purchased or acquired which has lessened in value since its purchase, and so on.

Totaling up all of the assets and likewise all of the liabilities, and subtracting the one from the other, the difference will represent either a surplus or a deficit—a surplus if the assets are the greater, and a deficit in the contrary case. As the balance sheet is a ledger account, and must, therefore, be a balanced statement, when the assets exceed the liabilities, the difference or surplus is placed below the liability column; on the other hand, when the liabilities exceed the assets, the difference or deficit is placed below the asset column.

ing, it has been set down with the income on one side and the "outgo" (if the liberty may be taken of calling it such) on the other. On the income side, the first item is that of gross earnings, this including the total value of all shipments billed to customers. On the outgo side, the first item is the cost of shipments billed, meaning by this the total cost inclusive of everything—namely, factory cost, with expenditures for patterns, dies, tools, inventory adjustment, also selling, administration and other sources of expense. The difference between these two sets of figures gives the net manufacturing earnings, which may be either a profit or a loss. There are still certain deductions to be made from these consisting, of the depreciation on property, plant and materials. When such have been allowed for, the remainder will then indicate the net profit (or it may be the net loss) from manufacturing operations.

Income Other Than Manufacturing.

Reverting again to the income side of the statement, it will be seen that besides manufacturing profits, there are other sources of income, consisting of interest, and dividends due from investments of one kind and another, royalties, etc., while to offset these, there will be found on the outgo side of the statement deductions, including interest payable on bonds, mortgages, notes, etc., also discounts on bills receivable and sinking fund charges. If these be respectively added to and subtracted from net profit from manufacturing operation, the result will be the net income or

owned or of accounts receivable, etc., there is finally left a surplus (or a deficit), which will be in accord with the surplus or deficit shown by the balance sheet.



LIGHTING OF WORKSHOPS.*

By W. J. May.

THE question of light in a workshop of any kind is of the first importance. Top-lighting usually provides the best general light, whether it be natural or artificial, the diffusion usually being so much better than side-lighting, which shows on one side only, although if two sides can be made available for the admission of light, so much the better. In any case, the windows for the admission of natural light should be large, while the window and sash-framing should be as small as possible.

If possible, with natural top-lighting, the light should come from the north or north-west; but in any case the windows should be so arranged that the direct sunrays do not fall directly on the articles being worked on. This can be done by arranging the roofs on the ridge-and-furrow principle, with glass on the north side, and then, by carefully whitening the inside of the slated roof, very little light will be lost. There is little need of special preparation of whitening mediums, but if ordinary ball whiting is reduced with skimmed or separated milk, to the consistency required, and a little carbolic acid added to prevent decay, the wash will not come off, making an annual renewal each September sufficient for all practical purposes.

Where ordinary skylights are used, a thin blind should be provided to obstruct the direct sunlight, this being on a roller conveniently placed, the blind only being used during sunshine. If treated with a weak solution of sulphate of copper, the blinds last much longer, and, as the treatment costs little, it may well be considered. In arranging for side-lighting, as large windows as possible should be used, and these should come as low down as possible, because, during at least part of the year, natural light is feeble.

Obscuring the Light.

Roller blinds of scrim should be used to obstruct direct sunlight when it becomes too powerful, and where it is desired to prevent the workpeople from too much window-gazing, rolled or otherwise obscured glass may be adopted without much light reduction, only the lower panes, of course, being of this material. Paint and other substances which obstruct the passage of light should not be used for workshop window obscuration, and for temporary exclusion of

*From the "English Mechanic."

Income and Profit and Loss Statement.

<p>Gross Earnings Shipments billed</p> <p>Other Income. Interest on notes receivable, Dividends on stock and bonds in other companies. Royalties.</p> <p>Net Income Surplus for the year.</p>	<p>Cost of Shipments All expenses, including factory cost and expenses of patterns, dies, tools, inventory adjustments, selling, etc.</p> <p>Net Manufacturing Earnings Profit.</p> <p>Deductions. Depreciation on property, plant and materials.</p> <p>Net Profit from Manufacturing Operations Profit.</p> <p>Deductions from Income Interest on bonds and mortgages, Interest on notes payable, Discount on bills receivable, Sinking fund charges.</p> <p>Net Income Surplus for the year.</p>
<p>Profit and Loss Credits. Surplus from preceding balance sheet, Profits on bonds and mortgage certificates purchased and retired. Miscellaneous.</p>	<p>Profit and Loss Charge Dividends on capital stock, Depreciation on securities owned Miscellaneous. Surplus as per balance sheet.</p>

Profit and Loss.

While the balance sheet shows in part the financial condition of the corporation, it still needs to be rounded out by what is known as the income and profit and loss statement. As its name implies, this gives the sources of income of the corporation and its net profit or loss for the year. For convenience in explain-

ing the surplus for the year. If to this be added next certain credits, such as profits on bonds or mortgage-certificates of the company which have been purchased and retired, provided there are any such; and, likewise if from this total be subtracted certain charges or debits as dividends on the capital stock of the corporation, depreciation of securities

very bright sunlight, blinds should always be fitted.

Artificial Lighting.

For general artificial lighting, the whole of the roof (or ceiling) and the walls should be kept whitewashed. Fairly powerful lights should be installed and so arranged that the light is thrown upward and outward, thereby causing a diffused light to be spread over everything; the intensity, of course, varying with the power of the lights. Such lights should be well up in the place to be lighted, in all cases being three or four feet above the heads of the persons working under them.

Low power lights should also be put in for lathes and other tools, and these should be of an adjustable character. In some cases, suspended lights which will slide or in some other way move vertically will be preferable, while in others simple swinging brackets with two or three joints will give the greatest service: in each case the object being to provide the most convenient form of lighting for any particular machine or process.

Question of Artificial Lighting.

For convenience, electric lights are about best; but very many workmen prefer gas, as this, they say, does not tire the eyes so much—a point possibly they are quite competent to judge so far as they are personally concerned. For many temporary purposes portable appliances can be used, for instance, oil in conjunction with compressed air: but for numerous purposes, lamps of some kind are quite a necessity. Close quarters in which to work will largely govern the form of lamp best suited, and then, again, the vibration caused by the use of hammers and percussive tools will render many otherwise desirable lamps impossible of service.

For the foregoing reasons, more than one form of lamp becomes necessary where general work is done, and these lamps should be kept in the stores ready for use, and, when done with, should be at once returned, so that they may be got ready against the next time they are wanted.

The material on which work is done has a rather strong bearing on the methods of lighting adopted, because while one particular material, by reason of its absorbing light, will require special brilliancy, another, for the opposite reason, will require a more subdued form. If you are working on, say, black velvet, a very strong light will be necessary; but, on the other hand, if you are working on polished metal, the same light would cause such a glare and glitter that the eyes would be dazzled, and work could only be carried on in a very uncertain manner.

Light Per Person.

No fixed rule can be made as to the amount of light needed per person employed in any particular trade if calculations are based on the candlepower required; but sufficient light for each particular individual must be provided, or both work and workman will suffer, and result in a reduction of output.

Personally, the writer does not believe that working by artificial light produces the results which occur where only daylight is used; but, at the same time, in most places artificial light has to be used to some extent. This is, of course, unavoidable during part of the year.



HIGH-SPEED TOOL PRACTICE.

By Andrew Barton.

THE introduction and now almost exclusive use of high-speed tool steel has revolutionized the construction of machines both in detail and general structure. They are built with a knowledge of the power expected from them. This power is, however, much greater than that of the older machines built at the time when machine-cut wheels were a rarity, and it is not every firm that can supplant a bank of machines and lathes entirely with others of a modern design. That being the case it is well to keep in view what can be done with existing machines as regards the adoption of high-speed tool steel.

No Standard Rule.

No hard-and-fast rule can be given for the practice of any one shop or group of shops. Even if it is assumed that the operator is to work at a specified machine for some years on a stretch, it does not follow that he has nothing to judge regarding the materials brought before him. Further, it is desirable to have only one class or brand of tool steel in the shop or group of shops. Several makers, as well as works managers, stipulate the use of different grades for the harder steels. For the general class of castings and forgings that present themselves to general engine builders any chosen brand can do all and more than is expected of it, and the difference, if any, it may have from that of another brand for doing a piece of work, is too trifling to be of consideration. This will greatly add to the efficiency of the shops; at the same time it leaves the operator with one choice only, viz., what speed at which to run the machine or lathe to deal with the cutting of the material before him.

The quality of castings from any one foundry differs greatly. The position for casting, the ready chilling of any part, the grit and inferior quality of material

that locates at the upper side when casting, are all factors that need consideration. Similar considerations apply to wrought iron and steel forgings, although to a lesser degree. The keenness of tools evinces skill on the part of the operator—the one who alone has to choose. The harder and closer grained steels will enable him to use a keen tool. In these circumstances, high-speed is essential for economy, and the power absorbed is a minimum. However, if the keenness is excessive for duller and coarser steels, the point will crumble away, thus necessitating re-grinding more often than necessary. In view of all this, it will be advisable to pick out a few instances, and give the methods adopted, which have been based upon good practice, as a guidance to others.

Practical Examples.

Take a flat-steel forging that has anything up to 5-8 inch a side to be machined by planing. If it is a broad surface, two tools can be used. The first cut should be taken with a keen tool, to leave 1/32 in. oversize, at about 40ft. to 50ft. per minute cutting speed, and with a feed of 1-16 in. or so. Then a broad tool should be run across at about the same speed, leaving a brown paper or so, and known as the "seuffing" cut. The speed during skimming should be reduced, but a coarser feed used, say 1-4 in. to 3-8 in.—leaving a good smooth surface. With iron castings, the roughing cut is the same. The "seuff" and "skimming" are, however, united in one, which is done by a good flat-nosed tool with less keenness and at a speed of about 30ft. per minute. However, if it should be a working surface, it is desirable to take a "scrape" across it—cutting in a direction at right angles to the "roughing" and "seuffing" operations.

With regard to brass castings, speeds up to 100ft. per minute and more are economically used. However, if castings are not "puddled," the grit and sand exposed to edge of tool is very treacherous—and necessitates constant attention. The object of the operator in such cases should be to set his tools so as to get well under the surface—thus exposing as little as possible of the keen edge.

Of no less importance is the grinding of the tools. Whatever brand of steel be in use, the same points apply. The old grindstone with a drip of water, and tools ground by hand pressure, if carefully done, is sound practice. The wet emery stone with too much pressure causes cracks and often permanent injury to tools. The foregoing is an abstract of an article, appearing in a recent issue of the "Machine Tool Engineer."

MACHINE SHOP METHODS ^A_N^D DEVICES

Unique Ways of Doing Things in the Machine Shop. Readers' Opinions Concerning Shop Practice. Data for Machinists. Contributions paid for.

INSERTING AND CUTTING OFF BRASS PLUGS.

By W. D. White.

PREVIOUS to the introduction of a non-explosive gas, the two gas storage reservoir tanks installed underneath each railroad passenger car had, as a precaution against explosion from fire, 50 to 80 $\frac{3}{8}$ inch holes, plugged with lead located on each tank shell. The tools here described were for screwing brass plugs in these holes and for cutting off the projecting end of the plug.

Fig. 1 represents the tool for screwing in the plugs, which were 7-16 inch diameter x 1 inch long, with pipe thread for one half the length. One end of the plug was inserted in the hole in the centre of the chuck at (K). When the power was turned on, the shank (C) first turned in the direction of motion, and by means of a connection through the post (F) with the eccentric piece

of its intersection with the groove (L) in the post of the body of the chuck, kept the chuck proper and shank intact.

The cutting-off tool is represented by Fig. 2. The opening at (M) was a reamed hole, and (R) a milled slot across the face. These openings admitted the bolt piece (B) which carried the hardened steel cutter (E), and which was held by means of the washer (F) and screw (I). The lever (D) was held by pin (H) in slot (Q), and intersected the slot in piece (B), also the slot in the lower end of the shank (C). A vertical reciprocating movement of the shank (C) caused a horizontal reciprocating movement of piece (B), likewise the cutter (E), pieces (B) and (C) being connected by means of lever (D).

The pieces (B and E) were made of tool steel hardened. (J) was a key placed in the post and kept shank (C) from turning on same. The compression spring (G) held the tool open to receive

drawn across the centre of the hole at (T), took the projecting end of the plug off flush with the tank.

It was estimated that two men with these tools turned out 16 tanks per day, where formerly 6 men were only turning out 7 in the same time. It is possible that tools got up on the same principle, could be used for other and similar work.



TRIED AND PROVEN SHOP KINKS.

By D. A. Hampson.

Patterns for Handwheels.—Very frequently the specifications for special machinery call for the use of handwheels. They may be needed to replace broken ones, or be required for jigs, fixtures and special devices. Only the plainest handwheel pattern can be made in a day's time. If the wheel is "dished," or if its arms are other than radial, and if the size runs up to 12 or 14 inches in diameter, the cost of making a pattern is worthy of consideration. Again, unless care is exercised at the foundry in handling and in storage, a handwheel pattern is in poor shape after a few score castings are made from it.

Some time ago the writer, in anticipation of a considerable demand for handwheels, hit upon the following scheme for acquiring substantial handwheel patterns at a low cost, while at the same time standardizing their size and design in the shop and on various shop products. An inspection of the 50 odd machine tools in the plant showed either three, four, five or six arm wheels ranging in size from 4 inches to 14 inches. It was decided to adopt the three and five arm wheels. Those which in general shape were harmonious, it was decided to copy.

Such of the wheels selected and not in use were removed. A wood plug was driven in the centre holes and the "patterns" were sent to the foundry to have "one off." The handwheels themselves were returned and replaced on the machine the same day, so no trouble was experienced there. When the castings were received from the foundry they were cleaned, filled and painted, and finished with two coats of shellac. These became, then, our real handwheel patterns—smooth, true, of pleasing design, and of low cost. Moreover, they were practically impervious to dampness, warping, and the ravages of long service.

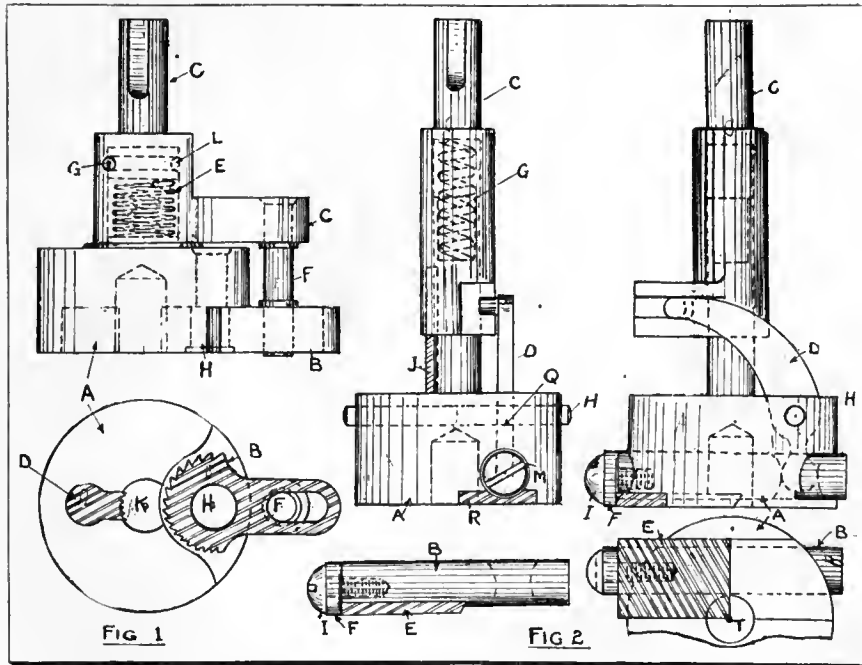

INSERTING AND CUTTING-OFF BRASS PLUGS.

(B), carried the latter with it, causing the inserted end of the plug to be firmly gripped between (B) and the hardened steel piece (D). The pieces (D) & (B) were made of cast steel and hardened. They had teeth cut on the faces in contact with the plug. The pin (H) holding eccentric (B), and the pin (F), were made of cast steel. The releasing spring (E) held the chuck open to receive the work. The pin (G), by means

of the work, which was bored out at (T) for this purpose. The shank (C) was bored to fit on to the post of body (A). It was also bored out to admit compression spring (G).

In operation, the tool was placed on the projecting end of the plug. With the power turned on, a steady downward pressure on the air drill caused the shank (C) to act upon the cutter (E) as afore described. The cutter, being

As for the other handwheels, watching our chance, when the tools were idle for a day, we removed the wheel selected and made our own metal pattern from it. When the round was completed, we had 4in., 6in., 8in., 10in., 11in., 12in., and 14in. handwheels, most of them being 3 and 5 arm style, and of a total value, if made up in wood, of a good round \$100. They had actually cost us less than \$15 to make.

• • •

Making a Better Fit in Lathe Cut Threads.—Most machinists have used nuts or threaded pieces to fit up a job they were threading in the lathe. Most of them too have worked carefully to get a nice fit and have found to their surprise that although the nut fitted well on the end, it was loose after it had been screwed on its own length. The reason for this is that the first thread is a "fat" one, the first thread being the one toward the tailstock when cutting R.H., and unless the lathe is unusually stiff in all of its parts and all gibs very tight, this is bound to occur. When the tool strikes the end of the work, it is cutting on one side only for a half revolution, and on one side more than the other, for the second half. Not until a full (complete) thread has been reached does the tool become evenly balanced. On that first thread, the tool and the looseness of the machine unite in springing away from the work, leaving that full thread.

By grasping the handle which moves the carriage and forcing it ahead, offsetting any slackness thereby, as it moves in the direct of the threads, the thick thread can be prevented or removed. It takes a little skill and practice to do this, but its practice will keep many a piece from the scrap pile.

• • •

Using a Drill For a Counterbore.—Counterboring in steel and wrought iron and the squaring out of "blind" holes in any metal are notoriously hard on tools. Counterbores, end mills, and end reamers are expensive tools to buy; they require slow, careful operation, and their regrinding possibilities are remote in case of breakage. In our shop, we had a considerable amount of this work to do in tool-making, and one of our manufactured articles, made in thousands, had a blind hole in each piece. Needless to say, the tool cost was ever before us; it being up to the writer to keep it down, and the method finally adopted of keeping it down will be related.

The manufactured article spoken of was made in a variety of sizes, one of which will serve as an example. A 5-16 inch hole $\frac{1}{8}$ inch deep was required in wrought iron. This hole "broke out" in another hole which had to be put in

first. The centre of the 5-16 inch hole was 7-64 inch from the edge of the larger hole. Couple with this the fact that the 5-16 inch hole had to have a flat square bottom and that no centre hole for a pilot could be left in the work, and you will realize our proposition.

The solution of the problem was ridiculously simple—an ordinary twist drill. All of this class of work we performed in jigs or Graham jig vices, therefore, the drills were guided by bushings. The work pieces were first drilled with a 5-16 inch drill, setting the machine so the point would go to the $\frac{1}{8}$ inch depth. This was followed by another drill, ground square on the end, which finished out the hole. An inexpensive fixture on the tool grinder sharpened the squaring drill quickly with an 8-degree clearance, which we found to

A CONTRIBUTOR'S LETTER.

I am enclosing some ideas which I have found extremely useful, and believe they may be so to others (yes, I believe in the "pass it on" game, both going and coming). For the idea, "Making a Better Fit in Lathe Cut Threads," I am indebted to the Canadian foreman under whom I was apprenticed, and to whom I owe the thorough training I received in the shop.—D.A.H.

be about right. The entire result was highly satisfactory; the drills were trouble savers, money savers, and work producers.

If there is a cheaper small tool than a twist drill, the writer does not know of it. It will wear down to the last inch, and is a glutton for use and abuse.

—•—

CHEAPER FUEL FOR MOTOR CARS.

UNDER the above heading, the Times recently contained the following report which will no doubt interest a large number of owners of motor vehicles throughout Canada, in view of the high price which petrol fuel has now reached:—

"By an invention which has just been patented on behalf of the British Motor Car Co., the regular use of a cheaper fuel in motor cars has now become possible, and it is hoped that early negotiations will be entered into with a view to a settlement of the strike of taxi-cab drivers in London, which began eleven weeks ago.

"Although petrol forms less than one-half of the constituents, the engine

power of the car has in no way been diminished by the use of the cheaper fuel. The latter was, however, useless for the purpose of starting engines. This difficulty has been overcome by the construction of an apparatus which is supplied with pure petrol from a small independent tank, and is used only for the purpose of starting. Mr. Worby Beaumont, consulting engineer of the Royal Automobile Club, has reported that the apparatus is 'simple, effective and not liable to disarrangement or to be the cause of any danger,' and that it is applicable to any kind of petrol engine as used in motor vehicles.

"Experiments conducted by the British Motor Car Co. show that the fuel has a higher mileage per gallon than pure petrol. We understand that the company will be able to sell the fuel to the drivers at 21 cents per gallon—the cost price. This is 5 cents a gallon less than the price which the men refused to pay for petrol when they went on strike."

—•—

INDUSTRIAL ACCIDENTS.

DURING the month of February, 485 industrial accidents were recorded by the Department of Labor; of these 85 were fatal and 400 non-fatal. This is 15 fewer fatal and 9 more non-fatal than were recorded in January. The record for February, 1912, was 66 fatal and 391 non-fatal accidents. The greatest number of fatal accidents occurred in the steam railway service and in the mining and lumbering industries, the figures respectively being 17, 12 and 11. The greatest number of non-fatal accidents occurred in the metal trades, there being 140 workmen injured. The steam railway service came next with 83 injured.

—•—

N. S. STEEL CO. PLANS.

IT is understood that the Nova Scotia Steel and Coal Co. is to spend over \$1,000,000 on Sydney mines this summer. A coal mine, which is to be opened near Pond Street, in the heart of the town, will be electrically operated. It will be one of the most extensive coal mines in Nova Scotia and the biggest producer in the company's chain, requiring 1,500 men to man it. A coal washing plant to cost \$150,000 will be erected.

It is also intended to construct a 50-ton open hearth steel furnace, together with a battery of gas producers. This, when completed, will give the Sydney mines one of the most modern steel plants in Canada, in addition to the fluid compression plant, which is the only one on the North American Continent.

DEVELOPMENTS IN MACHINERY

A Record of New and Improved Machinery Tending Towards Higher Quality and Economical Production in the Machine Shop, Blacksmith Shop or Planing Mill.

A MECHANICAL CYLINDER LUBRICATOR.

FOR the lubrication of engine cylinders by force feed, the Lunkenheimer Co., Cincinnati, Ohio, has developed a new type of mechanical oil pump. It possesses a number of interesting features, among which may be mentioned the accessibility of the parts, regulation of the feed with provision for supplying a greater amount of oil than usual in case of emergency, ease of filling and a sight feed for every outlet. Three sectional elevations are reproduced in the accompanying drawings.

Lubrication of engine cylinders by force feed has been proven to be by far the most satisfactory. It is not only more efficient, but it is also more economical. To obtain satisfactory results however, by force feed lubrication, great care should be exercised in the selection of a properly designed oil pump, and unless one is used that is absolutely dependable, practical and durable, the old method of hydrostatic lubrication had better be resorted to, as considerable damage may result from a poor pump.

Feed Regulation.

Attached to the operating rod RB-1754 Figs. 2-3-4, is an adjustable coupling B-50375 which can be moved up or down on the rod, and its location should be governed by the speed of the engine. If a high-speed engine, the coupling should be placed some distance from the end. The longer the stroke of the rod, the greater the supply of oil.

Adjustment of the quantity of oil per stroke of piston is made by the nut RB-172, attached to the end of the piston S-1608, Fig. 3. By means of this nut, the effective stroke of the piston can be regulated; the lower it is permitted to travel, the more oil is pumped. Spring SB-60 is provided to prevent the regulation from unsetting.

Every oil outlet has its own pump and feed regulation, so that different quantities of oil can be supplied from the different outlets, or if desired, the piston S-1608 of any outlet can be raised sufficiently to prevent the hole (B) in the base of the cylinder X-4 from being

supplied, whether the pump is operating or not.

Large Filling Hole.

The reservoir is easily filled with oil, owing to the large size of the filling hole. A hinged lid cap is provided which tightly covers the opening, preventing dirt from entering. Fitted within the opening is a brass strainer BW-146, of very fine mesh, which can easily be removed for cleansing.

This feature is very important, as it enables the engineer to ascertain at a glance whether the various cylinders are being properly lubricated, and he can rest assured that every drop of oil seen passing through the sight-feeds will positively be forced to the particular cylinder for which it is intended. The sight-feeds are exceptionally large and the dropping oil can plainly be seen from a distance.

Operation.

Although the cuts shown illustrate the Lunkenheimer Four Feed Lubricator, the operating description applies equally to the one, two and three feed mechanisms.

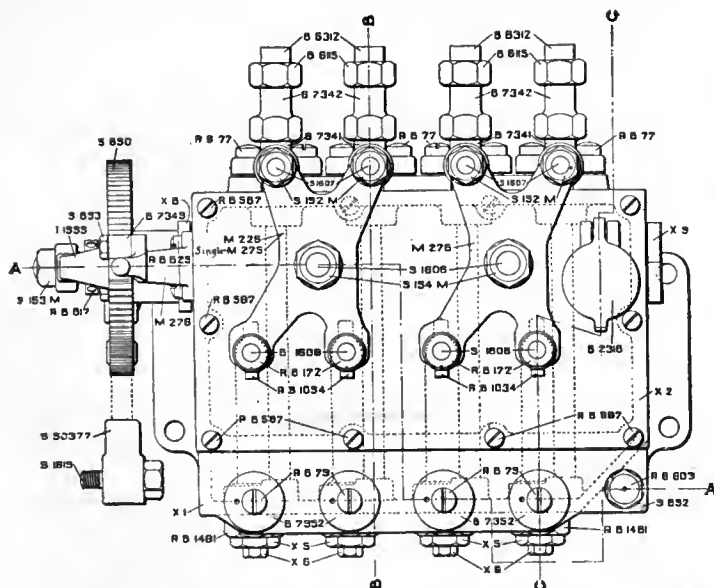

FIG. 1. MECHANICAL CYLINDER LUBRICATION. TOP VIEW.

In order to secure the greatest durability possible in this particular apparatus, such materials have been selected as will give the best results when working one against the other. Those parts subjected to the greatest wear are made of hardened tool steel. In addition, all parts of the pump are readily and easily replaced when necessary.

covered during the travel of the piston, and thereby entirely stop the flow of oil.

Should an emergency arise requiring the forcing of a greater amount of oil than that regularly supplied, this can be done by turning the ratchet wheel by hand, by means of the yoke I-1995 Fig. 2. Any amount desired can thereby be

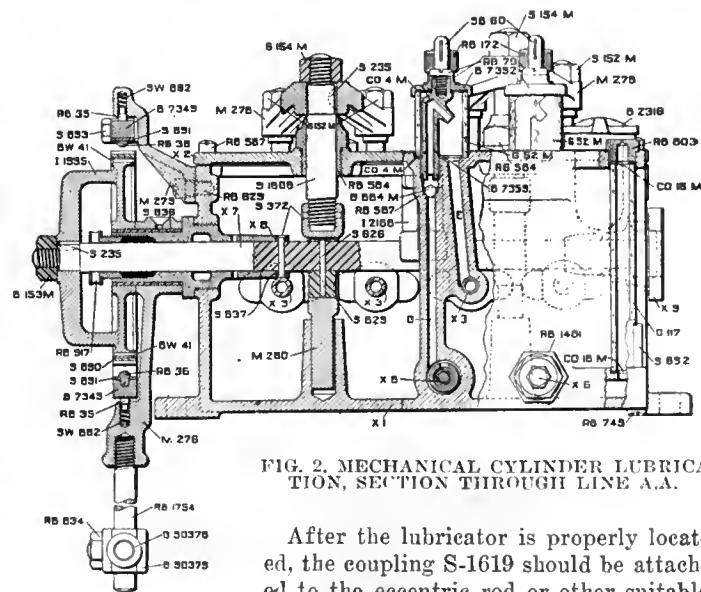

FIG. 2. MECHANICAL CYLINDER LUBRICATION, SECTION THROUGH LINE A.A.

After the lubricator is properly located, the coupling S-1619 should be attached to the eccentric rod or other suitable moving part of the engine. The gauge glass G-117 is provided to show the quantity of oil contained in the reservoir.

The driving mechanism is of the ratchet type, the ratchet plate S-891 engaging with the teeth on the driving wheel I-1995 on every forward stroke. An arm M-279 carrying a spring actuated pawl, is provided as a brake for the driving wheel, holding the wheel to the

by the flue-gas analysis and so long as the same grade of coal is used, the sprocket wheel should not be changed.

Referring to the sectional view, the course of the fuel is easily followed.

one beside it, the fuel-bearing grates between any two retorts are given a shearing motion in relation to each other, while moving in opposite directions; this prevents clinkers forming

the opening in the front air plate or by the side door. Removing the front air plates, gives free access to the under part of the stoker for repairs, etc. The stoker requires a small amount of head room, which permits of ample combustion-chamber space. The short air duct between the fan blower and the air

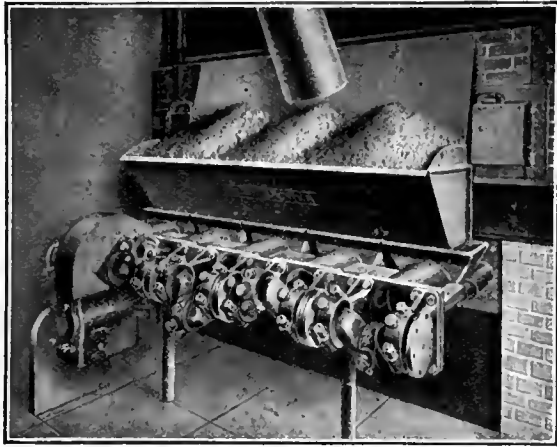

FIG. 3. FRONT VIEW OF STOKER.



FIG. 2. RELATIVE POSITION OF MOVING PARTS.

Dropping from the stoker hopper it is forced into the retorts by the plungers operated by the crankshaft on the front of the furnace. When the retorts become filled, the fuel is carried by the fuel-bearing grates which form the side

above the air openings. The reciprocating motion of the fuel-bearing grates gradually forces the coking and burning fuel towards the rear end of the furnace. Air is supplied to the fuel through the side tuyere openings.

space below the stoker is seen in the sectional view. This feature eliminates losses due to the friction of air through long air ducts and the necessary power to maintain the excess air pressure to overcome this loss.



FIG. 1. SECTIONAL VIEW THROUGH STOKER.

of the retorts. As these grates are operated in unison with the retort plungers and as each plunger is driven by a crank, set at a different angle from the

The driving mechanism of the stoker is visible from the outside and accessible. The air space beneath the stoker is reached through a door, or through

As the overfeed grates extend entirely across the stoker beyond the underfeed retorts, all of the partially burned fuel comes in intimate contact with air, and

the latter being of less pressure than the underfeed air is not destructive to the lighter fuel bed on the overfeed grates. At low ratings, this air pressure may be little or nothing, being regulated by the fireman operating the damper shown in the sectional view, between the air space and the overfeed reciprocating grate.

The Sanford Riley Stoker Co., Worcester, Mass., are the builders of this stoker.



LARGE HOT WATER HEATER.

ONE of the largest hot water heaters yet built was recently manufactured by the National Pipe Bending Co., New Haven, Conn., for the Wood Worsted Mills, Lawrence, Mass. This heater of the "U-Bend" type has a capacity of 125,000 pounds of water per hour, heating it from 100 degs. to 212 degs. by exhaust steam. It sets horizontally on cradles, is almost 9 feet long, 5½ feet in diameter, and contains 212-1¼ in. brass tubes expanded into a header.

The water enters at the front through an 8 in. inlet, and flows through a bank of tubes, passing longitudinally from front to rear, then to the front again, and again to the rear, making four passes before leaving through a water outlet of the same size, also at the front. The water is compelled to travel through the tubes explained above, by means of baffles on the header. These baffles divide the space horizontally into two main sections, and other baffles divide the upper section into three parts and the lower section into two parts as



LARGE HOT WATER HEATER.

shown by the accompanying illustration.

The steam enters a 10 in. inlet at the

top, and entirely surrounds the tubes, the condensation leaving the heater by a 4 in. drain at the bottom. All the tubes are brass; these having, in consequence, no action on the water, mak-



DETROIT "300" GREASE LUBRICATOR.

ing it suitable for washing or boiler feed. The shell, of steel plate, is not liable to corrode, because it is not in contact with the water.

This apparatus can be used as a storage heater by reversing the action, that is, directing the steam through the tubes

DETROIT "300" GREASE LUBRICATOR.

THE Detroit "300" Grease Lubricator is designed to feed grease, non-fluid oils and similar lubricants evenly, economically and efficiently. It is of like construction to the "Detroit Improved Standard," except that it has a heating passage and a large heating chamber. This heating chamber is of sufficient size to reduce all the lubricant in the reservoir to a thoroughly liquid condition immediately after steam is turned on, therefore, no time is lost waiting for the lubricator to warm up preparatory to feeding. Cold drafts, outside exposure or temperature variations do not affect the operation, the oil or grease in every part of the lubricator being maintained in a fluid condition at all times with an even rate of feed, through fine regulation. Maximum economy is, therefore, assured.

This lubricator can be installed either with both connections between the boiler and the throttle, or with the condensing tube above the throttle and the delivery or support arm below the throttle. In order to permit of either installation, there is attached to each lubricator, properly tagged with complete instructions, a choke to be screwed into the support arm in case the connections are made on both sides of the throttle. If both connections are above the throttle, the choke is not required.

The Detroit Lubricator Co., Detroit, Mich., are the makers of this specialty.



NEW FLEXIBLE INSULATED COUPLING.

THE Canadian Bond Hanger & Coupling Co., Alexandria, Ont., in addition to their extensive line of power

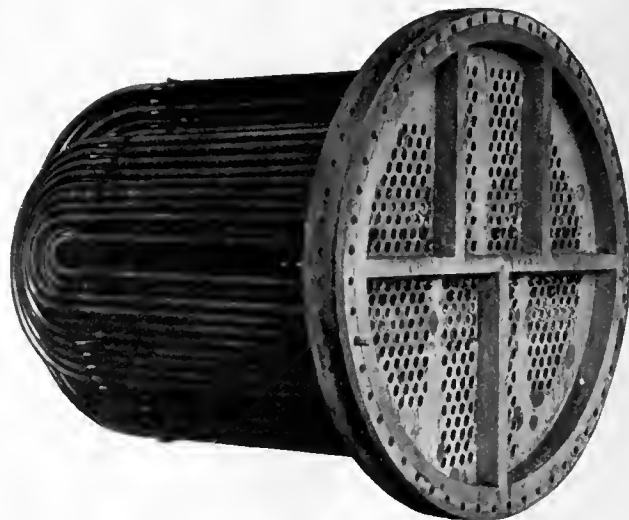

LARGE HOT WATER HEATER.

which are then surrounded with water. As a result, the water while larger in quantity, would be of lower temperature.

transmission machinery are now manufacturing the Grundy flexible insulated coupling for direct motor drives.

This coupling is manufactured in three parts, the two outer flanges being of east iron and the centre disc of specially selected leather or hard fibre with lugs on each side for transmitting the

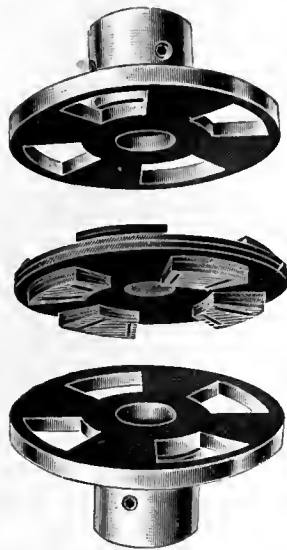

NEW FLEXIBLE INSULATED COUPLING.

power to the outer flanges. The lugs are securely cemented and riveted to each side, and on the larger sizes are bolted on and reinforced with steel plate.

The Grundy coupling is specially adapted for connecting motors to pumps, machine tools, sewing machines, wood-working machinery, printing machinery, fans, blowers, etc. It is a simple and effective device for connecting the two ends of shafting where it is difficult to get the bearings in perfect alignment or where they are liable to get out of adjustment, and is guaranteed by the makers to give less trouble and outwear



REMOVING SCALE FROM LOCOMOTIVE ARCH TUBES.

connected, and there are no loose eyeliners, rings, threaded pins or bolts to give trouble.



REMOVING SCALE FROM LOCOMOTIVE ARCH TUBES.

THE scale evil has made itself felt in the clogging up of the tubes used in modern locomotive boilers for supporting the arch over the combustion chamber. This particular fire box is now used by a number of prominent railroads. The baffle secures more perfect combustion of the fuel, and assists in the mixing of the products of combustion with the air admitted above the fire; it also acts as a reflector of the radiant heat of the fire into the escaping gases.

On account of the enormously high temperature over the fire, unprotected metal cannot be used for supporting the brick and tile of which the baffle is composed, therefore tubes containing water are employed. These tubes are curved in the form of an arch and communicate with the water jacket of the fire box, a continuous circulation of water through them being, therefore, assured. The locomotive arch tubes thus become part of the heating surface of the boiler, and as these tubes are directly over the fire and at its hottest point, water is, of course, evaporated in them at an enormous rate, and should the water contain any scale-forming ma-

tubes, the arch tubes have to be kept clean, because of the liability to overheating of the tubes, causing them to bag, blister and burn out.

To prevent the deposition or accumulation of scale the Lagonda Manufacturing Co., Springfield, Ohio, have recently perfected a special type of cleaner, in which the body or turbine part is exceptionally short, the cutting head being connected to it by means of a universal coupling. The operation of the apparatus is shown in the illustration.



NO. 1 FORMED CUTTER GRINDER.

THE No. 1 formed cutter grinder is a product of the Union Twist Drill Co., Athol, Mass., and its design and purpose refer to the grinding of formed cutters radially, so that these run true, and each tooth does its proper share of cutting. Provision is made for taking cutters up to 2 3/4 inches diameter and 3/8 inch thick.

The equipment of each machine consists of a 5-inch diameter grinding wheel, with 1/2-inch hole; a diamond tool for truing the wheel; a gauge for setting the wheel; a pin wrench for the grinding wheel nut; a dust pan for receiving dust from the wheel when not connected to an exhaust fan; work arbors for cutters, having holes 3/8 in., 1/2 in., and 5/8 in. diameter, and a countershaft with fast and loose pulleys of 6 inches diameter for 1 1/2 inch belt; the



NO. 1. FORMED CUTTER GRINDER.

anything else of its character on the market; at the same time, maintaining a perfect and silent drive in either direction. The "Grundy" can be closely

material, scale is sure to collect in these tubes quicker than in other parts of the boiler. Furthermore, while a thin layer of scale might be tolerated on the flue

pulley speed being 450 revolutions per minute. The net weight of the machine without the countershaft is 65 pounds.

The MacLean Pub. Co., Ltd.

(ESTABLISHED 1888.)

JOHN BAYNE MACLEAN - - - - - President
H. T. HUNTER - - - - - General Manager

PUBLISHERS OF

CANADIAN MACHINERY AND MANUFACTURING NEWS

A weekly newspaper devoted to machinery and manufacturing interests, mechanical and electrical trades, the foundry, technical progress, construction and improvement.

H. V. TYRRELL - - - - - Business Manager

EDITORIAL STAFF:

PETER BAIN, M.E., J. H. WILLIAMS, C. W. BYERS

OFFICES:

CANADA

Montreal, Rooms 701-702 East-
ern Townships Bank Bldg.

Toronto, 143-149 University
Ave., Phone Main 7324

Winnipeg, 34 Royal Bank
Bldg., Phone Garry 2313

Vancouver, H. Hodgson, 2640
Third Ave. West.

GREAT BRITAIN

London, 88 Fleet Street. E.C.
Phone Central 12960
E. J. Dodd

UNITED STATES

New York, R. B. Huestis, 115
Broadway, New York, N.
Y., Phone 2209 Rector

Chicago, A. H. Byrne
Room 607, Marquette Bldg.
140 S. Dearborn St., Chicago

CABLE ADDRESS:

Macpubco, Toronto. Atabek, London, Eng.

SUBSCRIPTION RATE:

Canada, \$2.00; United States, \$2.50; Great Britain, Australia
and other colonies, 8s. 6d. per year; other countries, \$3.00. Adver-
tising rates on request.

Subscribers who are not receiving their paper regularly will
confer a favor on us by letting us know. We should be notified at
once of any change in address, giving both old and new.

Vol. IX.

APRIL 17, 1913

No. 13

PRINCIPAL CONTENTS.

Concerning the Transmission of Power by Chain Drive.....	395-397
General	398
New Coal Washing Plant...Comparative Cost of Three Types of Power Plant...Efficient Workshop Lighting ...\$10,000,000 for Bridges.	
A Brief Statistical Review of Steam Boiler Explosions.....	399-402
Formation and Organization of a Large Mfg. Corporation.....	403-405
General	405-400
Lighting of Workshops...High Speed Tool Practice.	
Machine Shop Methods and Devices	407-408
Inserting and Cutting-off Brass Plugs...Tried and Proven Shop Klunks...Patterns for Handwheels... Making a Better Fit in Lathe Cut Threads...Using a Drill for a Counterbore.	
General	408
Cheaper Fuel for Motor Cars...Industrial Accidents ...N. S. Steel Co. Plans.	
Developments in Machinery	409-413
A Mechanical Cylinder Lubricator...A New Underfeed Stoker...Large Hot Water Heater...Detroit "300" Grease Lubricator...New Flexible Insulated Coupling ...Removing Scale from Locomotive Arch Tubes... No. 1 Formed Cutter Grinder.	
Editorial	414
Industrial and Construction News	415-418
Engineering ... Electrical ... Waterworks ... Muni- cipal...General Industrial...Railways...Bridges... Woodworking ... Building Notes ... Tenders ... Contracts Awarded ... Marine ... Trade Gossip... Personal ... Obituary ... New Incorporations ... Catalogues.	
Recent Judicial Decisions	419
General	410
Edson Shops of G.T.P....A New Blue Print Machine ...U. S. Tariff Bill.	
Selected Market Quotations	420-421
The General Market Conditions and Tendencies	421-422
General	422
C.P.R. Shops at North Bay...Industrial Disputes... I.C.R. Equipment Ordered.	

THE PURPOSE OF TECHNICAL SCHOOLS.

IN some recent issues of Canadian Machinery the question of Technical Education and the subject of Technical Schools as mediums for its acquirement were discussed. Evidences are not lacking that there is a growing disposition to lose sight of the education feature and to glorify the institution. Little thought is given to the personnel of those who will enroll as students, to their wants and to their expectations, a circumstance which forcibly indicates not a misconception but a lamentable ignorance of the A.B.C. of the technical education movement and purpose. Here, in Toronto, attempt is being made to foist upon the inhabitants a two-million dollar or more technical institution, by a body of men whose knowledge of actual requirements is conspicuously lacking. The erection of a palatial building, equipped with the most modern tools, appliances and equipment will fail to attract those whom the technical education movement is designed primarily to help.

Mechanics, generally, are somewhat sensitive in the matter of arrangements made, presumably for their welfare, and are inclined to feel as much at ease in a magnificent educative building, as most of us would feel were we invited to enjoy a pipe with King George V. at Buckingham Palace. We have universities in leading centres of the Dominion, where those who can meet the price may be instructed and trained for trade and professional work, and there is neither need nor reason for going into open competition with these. What our mechanics and operators want, and what they should make demand to get, is a number of modest, well equipped schools located centrally in manufacturing districts to which they may come in the evening, and from which they may go away with an addition to their stock-in-trade.

The distinction in architecture should be the least possible from that evidenced in a well-designed and laid-out factory, and in addition it should be the aim to have the internal arrangements and conditions correspond also to the fullest extent possible. Nobody cares whether the pie dish is of granite ware or earthenware; we are all more interested in the pie itself, and the latter, in this instance, consists of the instruction to be obtained. Aside from the question of magnificence, the staff more than the equipment or even the structure is the all-important consideration. Its personnel, to be of the highest value, should consist of men whose upbringing and training has fitted them to appreciate the needs of the individual student; in a word, such as will make the instruction the most useful, practical and effective in securing advancement for the recipient.

We must say again that there is too keen a disposition being displayed to erect and equip an institution which will surpass everything in sight of a like nature, and the circumstance is lost sight of that "every dog has its day," likewise every top-notch technical school, and that tomorrow some one-horse town will get the craze and take first place. We talk about the mad rush among the nations of the world to increase armaments, but who shall deny that there is more of necessity and wisdom in the latter than belongs to technical school buildings and equipment. It should not be necessary that twentieth century mechanics have to accept bricks and mortar in lieu of instruction, and our manufacturers will not only be serving their own interests, but that of our communities as well, when they set their faces steadfastly against every attempt in the direction indicated of every heterogeneous body of men on whom a little passing authority has had the effect of unbalancing the seemingly ill-assorted modicum of intelligence they were privileged to possess.

INDUSTRIAL ^A_N^D CONSTRUCTION NEWS

Establishment or Enlargement of Factories, Mills, Power Plants, Etc.; Construction of Railways, Bridges, Etc.; Municipal Undertakings; Mining News.

Engineering

Canning, N.S.—Bleukharn & Sons' axe factory has been destroyed by fire at a loss of \$150,000.

North Bay, Ont.—The C.P.R. are building new shops costing \$249,000, including locomotive and car departments.

Sault Ste. Marie, Ont.—J. F. Taylor, of the Lake Superior Corporation says, work on the steel plant extensions will commence before the fall.

Watrous, Sask.—The foundry of the Farmers' Machine Co. was opened for work on April 3. Mr. Minogue is in charge. The plant also includes a warehouse and machine shop.

Brantford, Ont.—The manufacture of motor fire engines in this city is under consideration, according to an announcement made by D. J. Waterous, vice-president of the Waterous Engine Works Co.

Markdale, Ont.—J. G. McLean of Owen Sound has asked the council for a loan of \$10,000, and agrees to erect a machine shop and foundry, 40 x 80, for the manufacture of steel nail kegs and repair work.

Paris, Ont.—Mr. Bradley has purchased the equipment of the moulding shop at the International Harvester Works and is moving it to the building erected by Rousell Bros, which he will convert into a foundry.

Medicine Hat, Alta.—The Alberta Machine Shop and Foundry, will as soon as the addition to the building is made, install more machinery, including planing machines, lathes, etc. The cost of the new machinery will be about \$10,000 and the cost of the addition to the building \$4,000.

Parry Sound, Ont.—The Riter-Conley Mfg. Co., Pittsburgh, is working on a contract for the erection of a blast furnace for the Standard Chemical Iron & Lumber Co., at Parry Sound. The contract includes one charcoal blast furnace with bins, skip furnace, including brick lining, east house, engine house and boiler house.

Electrical

Peterborough, Ont.—The Canadian General Electric Co. are enlarging their plant here.

Gananoque, Ont.—The town has accepted the Gananoque Electric Light Co.'s offer of a ten year contract for light.

Kamloops, B.C.—The council will spend \$65,000 on extensions and improvements to its electric lighting system. \$250,000 will be spent in constructing and installing an hydro-electric plant.

Montreal, Que.—Mr. W. J. Camp assistant general manager of the C.P.R. Telegraph, has made the statement that the company is contemplating the installation of another quadruplex line between Vancouver and Victoria, and another direct line to Seattle from the Pacific terminal in Victoria. The company has installed 120 new call boxes, which greatly facilitate the service, and Mr. Camp was impressed with the rapid developments on the island.

Oakville, Ont.—On Sunday, April 14, the electric lighting system in this city was completely disorganized, two men being electrocuted, owing, it is believed, to high and low tension wires coming in contact. The following were engaged by the mayor to investigate:—Messrs. A. L. Madge, W. A. Bueke, Elvin M. Wood, and John Watt, of Toronto, and Chief Engineer Sifton, of Hamilton.

Barrie, Ont.—The details are now almost complete for the formal installation of Hydro-Electric in Barrie. All the work is practically finished, but a definite date has not yet been selected. Some very pronounced changes in the lighting system will be introduced. The arc lights will be discontinued and tungsten lamps placed on all poles on the principal streets. This will, of course, add somewhat to the municipal lighting bill, but the expenditure is warranted.

Waterworks

Galt, Ont.—The Water Commission will construct a new trunk main at a cost of \$60,000.

Montreal, Que.—Purifying sewage plant to cost \$8,000, in Notre Dame de Grace Ward is planned by the Board of Control.

Quebec, Que.—Tenders for the extension to the Chateau d' Eau and the new intake at Lorette will be received by T. A. Jardine Forrester, consulting engineer

of the new water works, up to April 30.

Montreal, Que.—The city council is again considering the purchase of the Montreal Water and Power Co. Three years ago the controllers refused to appropriate the entire plant as a going concern. They now talk of acquiring ward by ward the company's properties. has been let to the Westinghouse,

Municipal

Wingham, Ont.—The local council will spend \$6,500 on machinery for making good roads if the ratepayers permit it.

Vermillion, Alta.—The burgesses will be called upon to sanction the raising of \$4,000 for cost of repairing highways, and also to raise \$4,000 for extension of electric and power system.

Ottawa, Ont.—The city council will engage a competent engineer to report on the cost of construction of a modern gas plant, together with the cost of manufacture and distribution of gas.

Perth, Ont.—The property holders will be asked to express themselves on the question of raising \$10,000 to pay the cost of waterworks suit, and to raise \$20,000 to build new streets in the town, on April 25.

Fernie, B.C.—The electors recently voted in favor of the by-law to authorize the raising of \$10,000 for extension of the electric light system in city. Tenders are expected to be called for debentures for this amount.

Gananoque, Ont.—The council has been urged to submit a by-law to the burgesses whereby the latter will have the opportunity of expressing themselves on the question of raising \$20,000, as a bonus to the Gananoque and Arnprior Railway.

Warton, Ont.—The ratepayers have expressed themselves in favor of the by-law to raise \$6,500 by debentures, to assist in paying off the floating indebtedness of the town and to pay for the installing of electric pumps at the power house.

New Westminster, B.C.—The city council recently decided to prepare by-laws to be submitted to the burgesses at an early date, calling for the raising of \$200,000 for general street improve-

ments and \$45,000 for the extension of waterworks system.

Medicine Hat, Alta.—Medicine Hat will spend the following sums if it adopts the report of its city engineer: gas main extensions, \$125,000; water main extensions, \$150,000; sewer extensions, \$250,000; new water and electric light plant and reservoir, \$400,000.

General Industrial

Toronto, Ont.—The Consumers Gas Co. will extend their plant into adjoining townships.

Glencoe, Ont.—The Glencoe Cannery Co. will purchase \$50,000 worth of modern canning equipment.

Winnipeg, Man.—The Hicks Co., 761 Croydon Avenue, will erect a garage and repair shop, estimated to cost \$25,000.

Nanaimo, B.C.—A wholesale commission house with \$30,000 capital will establish here, and operate a cold storage plant.

Wilkie, Sask.—J. Peacock of Maple Creek will erect a garage here. Reid & Kirkland are erecting a large tinsmithing shop.

Montreal, Que.—The renewal of the license of the Canadian Powder Co. for the manufacture of explosives on Perrot Island, near Montreal, is opposed.

Port Stanley, Ont.—The Fish Producers' Co. will install new cold storage equipment, and plan the establishment of a fertilizer plant. W. Robins, manager.

New Westminster, N.B.—R. B. Johnson is building a shoe factory. It is expected that most of the machinery will be installed in the course of two or three weeks.

St. John, N.B.—The New Brunswick Coal, Iron & Clay Co. has been organized with a capital of \$298,000 to develop deposits in this vicinity. H. W. Woods, president; D. K. Hazen, secretary and treasurer.

Humboldt, Sask.—A deal for the location of one of the largest and best equipped flour mills in the west has been closed. It is to be built by Hon. A. P. McNab, of Saskatoon, and will have a capacity of 100 barrels per day.

Berlin, Ont.—Berlin city council on April 7 decided to purchase from A. S. Gourlay, of Galt, for \$1,000, a strip of land, 60 x 160 feet, in return for which Mr. Gourlay agrees to erect thereon a shoe factory, 40 x 120 feet, three stories with basement.

Vernon, B.C.—The Dominion Cannery, Ltd., Hamilton, Ont., will probably take over the plant of the Vernon Canning and Jam Co., and locate in other towns near here. A new retort and much machinery will be bought. Mr. Richardson, vice-president, of Hamilton, is investigating.

No Tax on Yukon Coal.—The Canada Gazette announces that no royalty will be collected on coal mined in the Yukon territory for a period of five years. The royalty has been five cents per ton, but as the coal is of an inferior quality and the market area restricted, the government has deemed it wise to suspend the levy.

Railways—Bridges

Winnipeg, Man.—The C.P.R. will tunnel through Kicking Horse Pass at a cost of \$14,000,000. The tunnel will be 16 miles long.

Quebec, Que.—When the Premier returns from France, the matter of replacing, by steel structures, the bridges that have been washed away, will be taken up.

Ottawa, Ont.—The ratepayers of the township of Gloucester will vote on a proposition to give the Morrisburg and Ottawa Electric Railway a bonus of \$1,000 a mile.

Victoria, B.C.—The Canadian Northern Pacific Railway is applying for permission to develop hydro-electric power from the Nicolum River and will likely build a power plant below Yale, B.C. Jones Lake, south of the main line below Yale, will also be tapped for 50,000 horsepower.

Vancouver, B.C.—The G.N. Rly. Co. will take out the bridge on Broadway and put in a new one next year. The Victoria drive steel bridge will be finished August 1, 1914; the Clark drive bridge on April 1, 1914; the crossing over Commercial drive and Eighth Ave., by April, 1915; and Woodland drive viaduct by Sept. 1, 1915. Nanaimo St. bridge will be replaced by a heavier structure.

N.T.R. Operation.—Mr. E. J. Chamberlin, president of the Grand Trunk Pacific Railway, in reply to a letter of interrogation addressed to him by the Quebec Board of Trade last week, has written that the company intends to take over the Transcontinental Railway and live up to its contract with the Government as soon as the road from Moncton to Winnipeg is completed, when a large traffic from the west will come to Quebec in summer and the ports of St. John, N.B., and Halifax in winter.

In regard to the delay in the building of the Quebec Railway terminals and workshops, Mr. Chamberlain places full responsibility on the Transcontinental Railway Commission.

Montreal, Que.—A contract is reported to have been let by the general contractors for the Levis-New Brunswick Boundary section of the National Transcontinental Railway, to Mr. T. Daly, of Montreal, for the completion of work on this stretch of 130 miles. There is about 9 miles of track to be laid, some bridging, a good deal of ballasting and general finishing up. It is expected that the work will be completed by September 30th of this year. Tenders are at present under consideration for the supply of 1,732 long tons of 80 lb. rails for delivery June 1st at St. Anselme, Que., and 4,349 long tons of 80 lb. steel rails for delivery on the same date at Harvey Junction, Que.

Wood-Working

Michel, B.C.—Fire on April 12th did \$100,000 damage to the premises of the Frites Wood Co., Ltd., and others.

New Westminster, B.C.—The Brunette Sawmills Co. will spend about \$15,000 this season for new machinery and additions to the plant.

Toronto, Ont.—The Brunswick-Balke-Collender Co. will build a four-and-a-half storey brick factory on Hanna Avenue near King Street to cost \$60,000.

New Glasgow, N.S.—It is reported that Rhodes, Curry & Company intend opening a large branch woodworking factory at New Glasgow, similar to those in Halifax and Sydney.

Port Elgin, Ont.—The Collapsible Go-Cart Co., whose factory and machinery were recently damaged by fire to the extent of \$35,000 will make repairs, and install new equipment. W. Leadbetter, manager.

Montreal, Que.—Damage estimated at \$25,000 was done by a fire which broke out on Friday, April 11, in the sash and door factory of the Lauderville and Langevin Company, 157 Carillon St., Longue Pointe.

Welland, Ont.—The Quality Furniture Makers, Ltd., have been incorporated with \$40,000 capital stock to manufacture leather upholstered furniture. The company has secured the building of the Hamilton Tube Works on Patterson Ave. which it will remodel and equip. B. J. McCormick, H. L. Hatt and L. C. Raymond, all of Welland, and Alex. McDonald, Toronto, are provisional directors.

Building Notes

Port Dover, Ont.—The council will spend \$32,000 on a new high school.

Calgary, Alta.—The city will build a six-storey building, costing \$225,000, for housing small industries.

Charlottetown, P.E.I.—Hon. Charles Dalton, M.P.P., for Tiguish, will give \$20,000 towards building a sanitarium for tubercular patients.

Ottawa, Ont.—Tharle, Brown and Stewart, of Port Arthur, have been awarded the contract for a new armory in that town, costing \$150,000.

Toronto, Ont.—The city council have approved the granting of an additional \$600,000 towards building a new central technical school, bringing the total amount expended up to \$1,400,000.

Rodney, Ont.—The Lusty Lumber Co., Ltd., and the Canada Casket Co., suffered loss to their plants on April 10th to the amount of \$20,000, of which \$8,500 was insured. The fire started in the boiler room and spread to the saw mill.

Hamilton, Ont.—W. H. Cooper has been given the contract for building a twelve-room addition to Barton Street School, and W. H. Yeates was the successful tenderer on an eight-room addition to the Hess Street School. Barton Street addition will cost \$65,000, and Hess Street addition \$75,500.

Port Hawkesbury, N.S.—As a result of the destruction by fire of the plant of the North Atlantic Fisheries, some hundreds of tons of pipes, structural steel and machinery were reduced to old junk. This mass of twisted iron has been sold to Mr. Brister, a junk dealer of Halifax, who has engaged Contractor S. W. Hagerty of Mulgrave, to place same on cars. Rebuilding will commence soon.

Tenders

Ste. Rose Village, Que.—Tenders for the construction of an aqueduct and sewerage system will be received by J. A. Jolly, Sec.-Treas., up to Monday, April 28th. Engineers, Messrs M. M. Oumet, Lesage and Desroches, 15 St. Lawrence Blvd., Montreal.

Toronto, Ont.—Tenders will be received by the Town Clerk until 8 p.m. on Thursday, May 1st, for the completion of a main sewer, comprising about 7,000 lineal feet of 20-inch, 18-inch, 15-inch, and 12-inch piping, with accessories. The Corporation will furnish the pipes. Geo. Elliott, Esq., Town Clerk.

Chipman & Power, Engineers, 204 Mail Building, Toronto.

Toronto, Ont.—Contracts for break-water construction in connection with the waterfront improvements will be awarded next month. Plans and specifications for the work are well under way. The Board expect to do considerable work in the harbor this year.

Simcoe, Ont.—Tenders will be received by the Town Clerk until Wednesday, April 23rd, for the following works:—Contract "A"—Laying main sewer and sewage force main. Contract "D"—Furnishing east-iron pipes. Contract "G"—Sewage pumping machinery. Contract "P"—Sewage pumping station. Contract "S"—Tile sewer pipes. Contract "X"—Sewage disposal works. L. C. Gibson, Mayor; W. C. McCall, Town Clerk; Chipman & Power, Engineers

Contracts Awarded

Winnipeg.—A contract for building the new Isaac Broek school has been awarded to the Sutherland Construction Co. for \$214,860.

Calgary, Alta.—The contract for building a brass foundry to cost \$80,000, for the Robertson Western Brass Co., has been let to the Westinghouse, Church Kerr & Co.

Saskatoon, Sask.—The Saskatoon General Electric Co. have been awarded the contract for the electric light and power installation of the new plant of the Quaker Oats Co.

Victoria, B.C.—The contract for repairs to the British steamship Robert Dollar, which will cost approximately \$60,000, has been let to the Seattle Construction & Drydock Company by the Robert Dollar Steamship Co.

Toronto, Ont.—The following tenders were awarded on April 11 by the Board of Education, in connection with the Carlton St. School:—Masonry, \$55,696. H. Lucas & Co.; carpentry, Frank Armstrong, \$37,284; plastering, Haddock & Son, \$5,900; roofing and tin-smithing, J. T. Flowers, \$1,870; fire-proofing, James A. Wickett, \$5,261; iron stairs, Canadian Ornamental Iron Co., \$7,400; iron fences, Shipley Iron Wire Co., \$860.

Marine

Sault Ste. Marie, Ont.—Dr. Casoretty, the engineer of the Soo Dry Dock and Ship Building Company is here. It is intimated that the company intend to fulfil their contract with the city, which requires that active work in connection

with the construction of the Soo dry dock be commenced not later than end of this month.

New Glasgow, N.S.—The Canadian Government has awarded a contract to McDougall Bros., of Ottawa, for \$390,000, for the deepening of the East River between Picton and New Glasgow, N.S. The work includes a lock and a dam, and will give the Nova Scotia Steel and Coal Co. and other industries water communication to their plants.

Trade Gossip

The General Manufacturers' Agencies, Ltd., Montreal and Toronto, is now handling the line of steam, water and air specialties in Eastern Canada for Kieley & Mueller, New York City.

The Mead Electric Co., formerly located on St. George Street, Montreal, have been compelled by the rapid growth of their business to remove to more commodious premises in the Unity Building. The business consists chiefly of repair work, such as rewinding dynamos, correcting electrical troubles, etc., and the field hitherto covered has extended from Rimouski to Winnipeg. With the increased space and facilities now at his command, Mr. Mead hopes to extend his operations from ocean to ocean.

The Smart-Turner Machine Co., Ltd., Hamilton, Ont., have recently secured the following orders:—Mr. J. J. Morley Young, Waterford, Ont., Rotary Pump; The Dominion Vinegar Works, Hamilton, Ont., Centrifugal Pump; The Central Prison Farm, Guelph, Ont., Automatic Feed Pump and Receiver; The Hoards Cheese Co., Hoards, Ont., Duplex Pump; The Buffalo Ontario Refining & Smelting Co., Kingston, Ont., Triplex Power Pumps; The Cloverdale Creamery, Hamilton, Ont., Centrifugal Pumps; The Canadian Warren Axe & Tool Co., St. Catharines, Ont., Rotary Force Pump.

Steel Co., of Canada.—The annual statement of this company for the year ending December 31st, 1912, reports increased earnings, due partly to improved trade conditions and to the fact that the company has improved its plant and increased the efficiency of its operation, thereby reducing the cost of production. The new open hearth furnaces have been completed and put into operation. The work on the blooming, billet, rod and bar mills has been delayed. The two first mills are completed, and the rod mills will be in operation in the course of a few days.

The Electrical Maintenance and Repairs Co., 162 Adelaide St. West, Tor-

onto, have found business increasing so rapidly, that they have removed into larger premises. Until recently, they occupied only the upper floors of the above address, now they have taken the ground floor, and have converted it into an up-to-date electrical repair shop. The machine tool equipment, which was upstairs, has been transferred to the ground floor and re-arranged, so as to allow of no loss of time in the handling of work. An overhead carrying system, designed by W. D. Beath & Sons, Toronto, has been installed for carrying armatures and parts of motors to the benches and lathes, also to the baking oven and impregnating tank. This arrangement eliminates a great deal of unnecessary handling. The firm conducts a general construction and repair business. They have recently arranged with a European firm of manufacturers for a line of motors, general supplies and lamps. These will be carried on the upstairs floor, and in a week or so the firm will be supplying full lines of electrical equipment. The second floor which was formerly the machine shop, has been transformed into offices and storerooms.

Personal

Angus Smith, city engineer of North Vancouver, B.C., has resigned, his resignation being accepted by the council with regret. He will leave the city early in May.

Sir Percy Girouard, formerly Governor of Northern Nigeria, and now a director of Armstrong, Whitworth & Co., shipbuilders, of Newcastle-on-Tyne, is in Canada looking for business opportunities.

Charles Joseph Call has been appointed general manager of the Cape Breton Coal and Iron and Railway Company, Sydney. Mr. Call was for some years general manager of the Acadia Coal Co., with headquarters at Stellarton.

Gerald H. Moore has been appointed resident engineer of the Canadian British Engineering Co., Ltd., with offices at 324 Smith Street, Winnipeg. Mr. Moore is a son of the late Col. Moore, who was for some years head of the Mounted Police in the Winnipeg district. He was educated at South Kensington, London, England, and served his time with the Davey Paxman Co., of Colchester, England.

H. A. Harrison, who has been connected with the Toronto sales staff of the Canadian Fairbanks-Morse Co. for a number of years has quite recently joined the Bawden Machine & Tool Co. taking charge of the sales work for this

company. Mr. Harrison will give his attention particularly to the pump department, looking after the sales of the Bawden steam pump which has quite recently been placed on the market.

New Incorporations

The Vilter Mfg. Co., incorporated at Toronto, to manufacture steam engines and all kinds of machinery. Capital, \$40,000.

Midland Transportation Co., Ltd., incorporated at Toronto, as shipbuilders. Capital, \$40,000. Incorporators:—E. F. Burke, D. J. Burke, F. J. Burke, J. W. Benson, and D. H. Clark, all of Midland, Ont.

The Clensolene Refining Co., Ltd., incorporated at Toronto to treat waste, and to refine refuse and oils. Capital, \$40,000. Incorporators:—H. W. Copeland, S. A. Morrison, R. Wharton, J. Bowkett, H. J. Welch, all of Toronto.

Benson & Bray, Ltd., incorporated at Toronto, as timber merchants. Capital, \$200,000. Incorporators:—J. A. Benson, M. J. Bray, C. M. Tremeeer, F. W. Grant, all of Midland, Ont., and D. J. Turner, of Toronto, Ont.

The Booth Felt Co., Ltd., incorporated at Toronto to manufacture gaskets, and packings. Capital \$40,000. Incorporators:—N. E. Booth, E. W. Booth, T. R. Brawley, all of Brooklyn, New York; E. S. Sheppard and B. A. Booth, both of Gananoque, Ont.

The Dominion Bronze Mfg. Co., Ltd., incorporated at Toronto, to manufacture and deal in brass and metal goods. Capital, \$100,000. Incorporators:—D. M. Campbell, W. J. Hodgins, G. Fink, C. J. E. Whitney, and M. W. Kirkwood, all of Preston, Ont.

The Stratford Brass Co., Ltd., incorporated at Toronto, to manufacture and deal in brass goods. Capital \$100,000. Incorporators:—A. Hahn, of New Hamburg, Ont., J. R. MacDonald, John Whyte, D. McKenzie Wright, and R. S. Robertson, all of Stratford, Ont.

Canadian Lamp and Stamping Co., Ltd., incorporated at Toronto to manufacture and deal in all kinds of metal goods. Capital \$100,000. Incorporators:—G. E. Edmunds, W. T. Jones, B. F. Kiesel, C. S. Kellum, W. D. Armstrong, all of Detroit, Mich; A. R. Bartlett, and A. Braid, both of Windsor, Ont.

Catalogues

Wotan-Werke, Leipzig, Germany, are the makers of the Wotan-Shaper which,

judging from the illustrations contained in their catalogue, is an up-to-date machine.

Walton & Co., Birmingham, England, are manufacturers of pattern-makers' supplies, steel spring and other washers. In an advance price list just received, we find descriptions and prices of leather fillet, wood fillet, white metal letters, sheet brass letters, peg and cup dowels, dowel plates, rapping and lifting plates, etc.

The Bureau of Railway Economics, Washington, D.C., established by railways of the United States for the specific study of transportation problems, have recently published Bulletin 45, dealing with the relation between the miles of track laid and the rate of increase in improved farm land. Interesting facts have been deducted from a close study of this subject. Those interested may obtain a copy of this bulletin on application to the Bureau, at Washington.

The Lunkenheimer Co., Cincinnati, Ohio, have favored us with a number of booklets dealing with valves, cocks, etc. Each one is a complete treatise on the subject dealt with. For instance, one deals with the regrinding of valves, and contains full directions how to accomplish this, for every variety of valve, besides being illustrated with drawings. Other booklets deal with water gauges, water columns, oil cups, safety valves, reseaters for regrinding valves, oil pumps, whistles, cylinder cocks, cylinder lubricators, grease cups, etc. Engineers are invited to send for the complete set.

Cammell, Laird & Co., Ltd., is a name which is sounding louder and louder in firm set out to build a ship-Canada. Some time ago this Sheffield building plant at St. John, N.B., but a change in National politics caused them to cancel arrangements. However, they still count in Canada, and we have just received their catalogue of tool steel. From this, we learn that the Canadian British Engineering Co., Ltd., 847-863 Beatty Street, Vancouver, B.C., are their western agents, and F. H. Hopkins & Co., Victoria Sq., Montreal, their agents in the east. At their Cyclops Steel and Iron Works, Sheffield, they manufacture crucible cast steel for almost every purpose. In the introductory pages a warning is issued which is interesting. It says: "Quality depends largely on the brand of Swedish Iron used in the manufacture of crucible tool steel, the purest ores (i.e., those containing the lowest percentages of impurities, such as sulphur, phosphorous, etc.), commanding a very high figure."

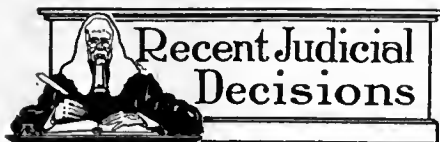

Ottawa, Ont.—In the Supreme Court, the appeal in *Kent Lumber Co. v. Kaizer* has been argued. The plaintiff in this case, worked in the defendant's sawmill. He had to attend to feeding a jump saw, and at intervals climb up on a table, cross it and descend on the other side to a circular saw. Along the side of this table was a shaft operating rollers, which brought the lumber down to the trimming saws. While crossing this table on one occasion, a part of his clothing was caught in the coupling of the shaft and he was badly injured. He sued for damages, claiming that defendants were negligent in not having the coupling protected, being a defect in the machinery under the Factories Act of Nova Scotia. The trial Judge dismissed the action, holding that it was not such a defect as the Act contemplated, and that the accident was due to the plaintiff's own negligence in passing too near the coupling while he was crossing the table. The judgment was reversed on an appeal by the plaintiff to the full court, and the lumber company appeals from this decision.

Toronto, Ont.—Judgment for \$721.96 damages in favor of the *Armstrong Cartage & Warehouse Co.*, of Hamilton, against the County of Peel has been granted by Mr. Justice Kelly at Osgoode Hall. The claim of the company arose through the collapse of a bridge on the road between Brampton and Cooksville, under the weight of a 5-ton auto truck, which was carrying a 4-ton safe. Under the 18,000 pounds weight the bridge gave way. The company claimed that it was deprived of the use of the truck for 82 days while it was being repaired. During that time they had to hire teams, at an excess over the cost of operating the truck, of \$8.94 a day. Mr. Justice Kelly found that the bridge was exceedingly dangerous, and that it was inconceivable that the defendants could have been in ignorance of its condition. He allowed the company for only 33 days' loss of use of the car, holding that there was delay in getting the car to the repair shops. Other items claimed were \$25 for towing the car to Cooksville, and \$279.44 for repairs.

Toronto, Ont.—Mr. Justice Middleton has ratified a settlement whereby F. W. Mossop, the Yonge Street hotel proprietor, will pay the widow and family of William Lawson \$2,450. The money will be paid into court and a payment

for maintenance will be made monthly. William Lawson was a millwright, and on May 14th, 1912, was helping to carry an armature for an elevator into the hotel premises, when he fell down an elevator shaft and fractured his skull, dying in 48 hours.

EDSON SHOPS OF G.T.P.

ALTHOUGH the size and importance of the Grand Trunk Pacific shops at Transcona, Man., have largely overshadowed the company's other plants of a similar kind in Western Canada, for an outlying point to which regular trains have been running only for a comparatively short time, Edson has been remarkably developed, the yards being extensive and the shops capable of handling practically any class of work. The car shop 260 feet by 40 feet, and 24 feet high, contains two through tracks, each of which can accommodate 6 cars. Adjoining is a building 102 feet by 15 feet and 12 feet high, arranged for offices, store room, and paint shop.

All classes of cars are handled at the plant, including passenger equipment, as many as 900 cars a month passing through the shops or yards. Employment is given to some 40 men. There is also a twelve stall round-house, with a large divisional shop adjoining, the latter being equipped with both metal and wood-working machinery.

A NEW BLUE PRINT MACHINE.

A NEW machine in the Canadian field which is fast gaining popularity through the efforts of the Eugene Dietzgen Co., of Toronto, is a continuous electric apparatus, known as "The Paragon," for making blue prints of any size, and in large quantities. It uses specially constructed blue printing are lamps for its source of light. These are suspended in a horizontal semi-cylindrical glass bed so that the are is nearly equally distant at all points of the printing surface, allowing all the light to strike the sensitized sheet without the use of "reflectors."

The original copy and the blue print paper are carried around the convex surface of the glass by means of a continuous canvas belt. This belt is driven by a rubber covered roller at the rear of the machine. This method draws the belt or apron very tightly against the glass, which, together with the sliding of the belt over the latter, gives excellent contact. An ingenious speed control allows for a range of from nothing to 14 linear feet per minute by simply moving a lever a short distance on a graduated arc.

Blue prints from regular tracings can be made on medium speed paper at the rate of about 12 linear (50 square feet) feet per minute. The excellent contact and speed control allow for making of all kinds of work, including Van Dyke negatives, blue line and black line prints. The last mentioned have heretofore been practically impossible on electric machines, due to the long exposure required, but can be made on "The Paragon" at a very fair rate of speed.

Orders for "The Paragon" Blue Print Machine have been filled since the 1st of February for the following:—The Provincial Government of Quebec; the Department of Agriculture, Ottawa; The Capital Office Supply Co., Ltd.; The National Steel Car Co., Hamilton, Ont.; the Department of Works, Toronto; The Rapid Blue Print Co., Hamilton, Ont.; The Algoma Central and Hudson Bay Railway Co., Sault Ste. Marie, and the City of Fort William.

U.S. NEW TARIFF BILL.

MACHINERY manufacturers and steel men in Ontario seem to be somewhat in doubt as to the terms of the new tariff bill introduced in the House of Representatives on April 7th by Mr. Underwood. Considerable surprise was expressed by several on learning that iron ore and rails had been placed in the free list. Canada seems to be more concerned with the cuts made in duty on food stuffs. There have been, however, several important revisions made in the tariff on certain metals. Iron ore is placed on the free list as well as railway rails which, formerly, were taxed as high as 34 per cent. under the Dingley Law. Other metals and machinery on the free list are structural material, brass, cash registers, linotypes, typewriters, chromic ore, coal, coke, copper ore, old copper, iron ore, needles, tin ore, barbed wire, emery ore and corundum, hoop or band iron, hoop or band steel cut to lengths or manufactured into hoops or ties for baling cotton or other commodity; railway bars made of iron or steel, and railway bars made in part of steel; T-rails and punched iron or steel rails.

On pig iron and scrap the new duty is 8 per cent., ad valorem; on muck bar and bar iron 8 per cent.; on structural shapes there is a duty of 12 per cent., being a large reduction; on iron and steel sheets a 20 per cent. tariff is provided (this included galvanized sheets and sheets covered with tin or lead); on steel ingots, billets and bars the duty is 15 per cent.; on wire it is 20 per cent. On cast iron pipe the duty proposed is 12 per cent.; on chains, 20 per cent.; on lap and butt-weld tubes and pipes 20 per cent.

SELECTED MARKET QUOTATIONS

Being a record of prices current on raw and finished material entering into the manufacture of mechanical and general engineering products.

PIG IRON.

	Per Ton.	
Foundry No. 1 and 2, f.o.b., Midland	\$19 00	\$19 50
Gray Forge, Pittsburg	16 75	
Lake Superior, charcoal, Chicago	18 00	
	Mont'l. Tor'to.	
Canadian f'dry. No. 1..	\$21 00	\$20 00
Canadian f'dry. No. 2..	20 50	19 50
Middlesboro, No. 3....	23 50	23 50
Summerlee, No. 2	25 00	26 50
Carron, special	25 00
Carron, soft	25 00
Cleveland, No. 1	24 25	25 00
Clarence, No. 3	23 75	24 50
Jarrow	25 50
Glengarnock	26 00
Radnor, charcoal iron.	30 00	34 50
Ferro Nickel pig iron (Soo)	25 00

BILLETS.

	Per Gross Ton.	
Bessemer billets, Pittsburgh	\$28 50	
Open hearth billets, Pittsburgh.	29 00	
Forging billets, Pittsburgh....	36 00	
Wire rods, Pittsburgh	30 00	

FINISHED IRON AND STEEL.

Per pound to large buyers:

	Cents.
Common bar iron, f.o.b., Toronto..	2.10
Steel bars, f.o.b., Toronto.....	2.20
Common bar iron, f.o.b., Montreal.	2.15
Steel bars, f.o.b., Montreal.....	2.25
Bessemer rails, heavy, at mill....	1.25
Iron bars, Pittsburgh	1.70
Steel bars, Pittsburgh, future	1.40
Tank plates, Pittsburgh, future...	1.45
Beams, Pittsburgh, future	1.45
Angles, Pittsburgh, future	1.45
Steel hoops, Pittsburgh	1.60

Toronto Warehouse f.o.b., Toronto.

	Cents.
Steel bars	2.30
Small shapes	2.40
Warehouse import, freight and duty to pay:	Cents
Steel bars	1.95
Structural shapes	2.05
Plates	2.05

Freight, Pittsburg to Toronto:

18 cents carload; 21 cents less carload.

BOILER PLATES.

	Mont'l.	Tor'to.
Plates, 1/4 to 1/2-in., 100 lbs.	\$2.40	\$2.40
Heads, per 100 lbs.....	2.65	2.95
Tank plates, 3-16 in.	2.60	2.60
Tubes, per 100 ft., 1 inch	9.00	8.50
" " 1 1/4 in.	9.00	8.50
" " 1 1/2 "	9.00	9.00
" " 1 3/4 "	9.00	9.00
" " 2 "	9.00	9.00
" " 2 1/2 "	11.50	11.50
" " 3 "	12.00	12.00
" " 3 1/4 "	13.75	13.75
" " 3 1/2 "	15.00	15.00
" " 4 "	18.50	18.50

BOLTS, NUTS AND SCREWS.

	Per cent.
Stove bolts	80 & 7 1/2
Machine bolts, 3/8 and less	65 & 5
Machine bolts, 7-16.....	57 1/2
Blank bolts	57 1/2
Bolt ends	57 1/2
Machine screws, iron, brass	35 p c.
Nuts, square, all sizes.....	4c per lb off
Nuts, Hexagon, all sizes..	4 1/4 per lb off
Flat and round head.....	35 per cent.
Fillister head	25 per cent.
Iron rivets	60, 10, -0 off
Wood screws, flathead, bright	85, 10 p e off
Wood screws, flathead, brass	75, 10 p e off
Wood screws, flathead bronze	70, 10 p e off

National-Acme "Milled Products."

Sq. & Hex Head Cap Screws	65 & 10%
Sq. & Hex Head Cay Screws	65 & 10%
Rd. & Fil. Head Cap Screws	45-10-10%
Flat & But. Head Cap Screws	40-10-10%
Finished Nuts up to 1 in. ..	75%
Finished Nuts over 1 in. ..	72%
Semi-Fin. Nuts, up to 1 in...	75%
Semi-Fin. Nuts over 1 in....	72%
Studs.....	65%
Discounts f.o.b., Montreal.	

WROUGHT IRON PIPE.

The following are Toronto jobbers' discounts on pipe. (Card weight) in effect from October 11th, 1912:

	Standard	Buttweld Black Gal.	Lapweld Black Gal.
1/4 3/8 in.	63	48
1/2 in.	68	58
3/4 to 1 1/2	72 1/2	62 1/2
2 in.	72 1/2	62 1/2	69 1/2 59 1/2
2 1/2 to 4 in. ..	72 1/2	62 1/2	71 1/2 61 1/2
4 1/2 to 6 in.	72	62
7, 8, 10 in.	66 1/2	54 1/2

X Strong P. E.

1/4, 3/8, 1/2 in. ..	64	54
3/4 to 2 in.	68	58
2 1/2 to 3 in. ...	68	58
3 1/2 to 4 in.	65	55
4 1/2 to 6 in.	63 1/2	56 1/2
7 to 8 in.	56 1/2	46 1/2

XX Strong P. E.

1/2 to 2 in.	43	33
2 1/2 to 4 in.	43	33

WROUGHT IRON PIPE.

The following are Montreal jobbers' discounts on pipe. (Card weight) in effect from October 11th, 1912:

	Standard	Buttweld Black Gal.	Lapweld Black Gal.
1/4 3/8 in.	64	49
1/2 in.	69	59
3/4 to 1 1/2	73 1/2	63 1/2
2 in.	73 1/2	63 1/2
2 1/2 to 4 in..	73 1/2	63 1/2	72 1/2 62 1/2
4 1/2 to 6 in.	74	64
7, 8, 10 in.	70 1/2	58 1/2

X Strong P. E.

1/4, 3/8	64	49
1/2 in.	65	55
3/4 to 2 in. ...	69	59
2 1/2 to 3 in. ..	69	59
3 1/2 to 4 in.	66	56
4 1/2 to 6 in.	65 1/2	58 1/2
7 to 8 in.	60 1/2	50 1/2

XX Strong P. E.

1/2 to 2 in. ...	44	34
2 1/2 to 4 in.	44	34

IRON PIPE FITTINGS.

Canadian malleable, 40 per cent.; cast iron, 65; standard bushings, 70; headers, 60; flanged unions, 65; malleable bushings, 65; nipples, 75; malleable, lipped unions, 65.

COKE AND COAL.

Solvay Furnace Coke	\$5.25
Solvay Foundry Coke	6.50
Connellsville Furnace Coke	5.25
Connellsville Foundry Coke	5.75
Yough, Steam Lump Coal	3.83
Penn. Steam Lump Coal	3.63
Best Slack	2.95
All net ton f.o.b. Toronto.	

OLD MATERIAL.

	Tor'to.	Mont'l.
Copper, light	\$12 05	\$10 75
Copper, crucible	15 00	13 50

Copepr, uncre'bled, heavy	13 05	12 00
Copper wire, uncre'bled..	13 05	12 00
No. 1 machine compos'n..	12 00	11 00
No. 1 comps'n turnings..	10 00	10 00
New brass clippings	9 15	9 00
No. 1 brass turnings	8 30	7 50
Heavy lead	3 25	3 00
Tea lead	3 00	2 75
Scrap zinc	4 00	3 25
Dealers' purchasing prices.		

SMOOTH STEEL WIRE.

No. 6-9 gauge, \$2.35 base; No. 10 gauge, 6c extra; No. 11 gauge, 12 extra; No. 12 gauge, 20c extra; No. 13 gauge, 30c extra; No. 14 gauge, 40c extra; No. 15 gauge, 55c extra; No. 16 gauge, 70c extra. Add 60c for coppering and \$2 for tinning.

Extra net per 100 lb.—Spring wire; bright soft drawn, 15c; charcoal (extra quality), \$1.25.

METALS.

Prices in cents per pound:

	Mont'l.	Tor'to.
Lake copper	16.25	16.25
Electrolytic copper	16.25	16.25
Spelter	6.00	6.10

Lead	4.60	5.50
Tin	51.00	51.50
Antimony	10.00	9.75
Aluminum	23.00	23.00

SHEETS.

	Mont'l.	Tor'to.
Sheets, black, No. 28....	\$2 85	\$3 00
Canada plates, ordinary,		
52 sheets	2 80	3 00
Canada plates, all bright.	3 70	4 15
Apollo brand, 10 ³ / ₄ oz.		
(American)	4 30	4 20
Queen's Head, 28 B.W.G..	4 50
Fleur-de-Lis, 28 B.W.G..	4 20
Gorbal's Best Best, No. 28	4 45
Viking Metal, No. 28....	4 40

NAILS AND SPIKES.

Standard steel wire nails,		
base	\$2 40
Cut nails	\$2 60	2 65
Miscellaneous wire nails..	75 per cent.	
Pressed spikes, 5/8 diam.,		
100 lbs.	2 85

FINE STEEL WIRE.

Discount 25 per cent. List of extras. In 100-lb. lots: No. 17, \$5; No. 18,

\$5.50; No. 19, \$6; No. 20, \$6.65; No. 21, \$7; No. 22, \$7.30; No. 23, \$7.65; No. 24, \$8; No. 25, \$9; No. 26, \$9.50; No. 27, \$10; No. 28, \$11; No. 29, \$12; No. 30, \$13; No. 31, \$14; No. 32, \$15; No. 33, \$16; No. 34, \$17. Extras net. Tinned wire, Nos. 17-25, \$2; Nos. 26-31, \$4; Nos. 30-34, \$6. Coppered, 75c; oiling, 10c.

MISCELLANEOUS.

	Cents
Putty, 100 lb drums	\$2.70
Red dry lead, 560 lb. casks, per	
cwt.	6.25
Glue, French medal, per lb	0.10
Glue, 100 flake	0.11
White lead, ground in oil, No. 1	
pure, 100 lbs.	8.40
Tarred slaters' paper, per roll...	0.95
Motor gasoline, single bbls., gal..	24 ¹ / ₂
Benzine, per gal.	23 ¹ / ₂
Pure turpentine	64
Linseed oil, raw	58
Linseed oil, boiled	61
Plaster of Paris, per bbl.	2.10
Plumbers' Oakum, per 100 lbs..	4.25
Pure Manila rope	17

The General Market Conditions and Tendencies

This section sets forth the views and observations of men qualified to judge the outlook and with whom we are in close touch through provincial correspondents.

Montreal, Que., April 14.—The machinery market was rather quiet last week, very little real business having been done. The Canadian Pacific Railway issued specifications for a small amount of machinery for replacement account at their Angus shops; but, apart from this, things were very flat.

Pig Iron, Copper, Etc.

There is little change to report in the pig iron situation, prices remaining firm at last week's figures. Copper maintains the slight advance it made last week, and tin is also firmer. The chief feature of the week was the strong advance in pig lead, which is now being quoted at \$4.60 per 100 lbs.

General Trade Conditions.

Generally speaking, the wholesale trade is fairly active, although collections and remittances have been disappointing. From Quebec and Ontario they have been slow, and from the West unsatisfactory. Firms of good standing are seeking renewals of paper maturing this month. This has seldom been the case previously. Building operations are beginning in earnest, and the result is a heavy call for builders' supplies. Money is hard to get from the banks, it

being difficult to borrow call money at 6¹/₂ per cent.

Toronto, April 16, 1913.—The A. R. Williams Co., have received orders from the Grand Trunk Railway to vacate the building occupied by them at 95-97 Front Street, Toronto, opposite the Queen's Hotel, by July 15. The new Union Depot will be built on the site. Their new quarters and head offices will be in the Copp Clark Building, Front Street, which they have bought, next door to the Queen's Hotel. They have also purchased a vacant lot adjoining this building, on which they expect shortly to build a warehouse. Plans are already being made. A considerable amount of their stock in their present building will be sold at special prices to avoid removal. The C.P.R. have issued specifications this week for machinery to be used in their Angus shops. This includes, lathes, drills, pipe machines, and turret lathes.

Pig Iron.

The impression among steel manufacturers is that the placing of iron ore by the American Government on the free list will have the effect of reducing

the cost of pig iron manufactured in Canada. One steel man went so far as to state that the price would be reduced a dollar a ton. Enquiries for pig iron during the week have been fairly good. Some orders pending are for very large quantities, and one placed last Saturday with Messrs. Drummond-McCall and Co. was for 500 tons. This buying is the result of a recent cut in price.

Tubes, Plates, Structural Steel, Etc.

A lot of business is pending in tubes, and dealers are figuring on considerable trade in the near future. Orders are coming in freely from manufacturers of agricultural machinery, these tubes being used for boilers on threshing machines, etc. Nails, which it was said would go up very soon in price, are still where they were a week ago, but everything points to an advance. The price on the other side of the line has stiffened for both nails and screws. Canadians it is said, are not taking proper advantage of this increase. The Dominion Steel & Iron Co., of Sydney, it is reported, have secured a waterfront warehouse in Toronto. Mr. Max Morrel, formerly connected with the Pittsburgh Perfect Wire Fence Co. will be their representative in Ontario. This firm has had a warehouse at Montreal for some time, but has not previously been represented in Ontario.

Things are beginning to stir at Sandwich, Ont., where the United States Steel Corporation are making prepara-

tions to build a large steel plant. A big banquet will be held in Ojibway or Windsor to celebrate the turning of the first sod. Mr. J. H. Farrell, president of the United States Steel Products Co. is going up to represent his firm. The first plant to be built will be the wire mill.

Metals.

Tin jumped a cent in price on Monday. Copper is hardening still further. The price of copper has risen from 15.75 to 16.25 during the week, both here and in Montreal. Little business is being done in aluminum and antimony. Spelter is firm. Copper is changing hands in large quantities. There is good business being done in old material, but generally speaking, big dealers are waiting for better prices. Small dealers are selling right along.

C.P.R. SHOPS AT NORTH BAY.

THE Canadian Pacific Railway Co. have commenced operations on the erection of large additional shops at North Bay, calling for a construction cost of \$249,000. A large erecting shop will be built where ten locomotives can undergo repairs at one time, together with accessory machine shops, etc. Another large building will be used for ear construction and repairs, and the plant when completed and working in harmony with the existing equipment will care for all the repairs and construction work on the Lake Superior Division, from Chalk River to the Soo and Fort William, besides the overflow from other divisions. It is estimated that an additional force of 150 or more employees will be needed.

Other railways centering in North Bay have plans out entailing large expenses, and this summer promises to be a very busy one.

INDUSTRIAL DISPUTES.

A CONTINUED improvement was reported to the Department of Labor during February with regard to conditions from the standpoint of industrial disputes. The number of employees involved in strikes and lockouts was over 300 less than the number for the preceding month, while the number of working days lost was less than the number lost

during January by over 16,000. Eleven disputes actually commenced during February, only one of which affected more than 100 employees. The only serious disputes of the month were those of coal miners on Vancouver Island, which continued from last month without a settlement being reached, and metalliferous miners at Britannia Beach, B.C. The latter involved upwards of 300 employees, and was not terminated at the end of the month. A dispute between the International Marine Signal Co. and their employees, at Ottawa, was settled after conferences arranged between the parties by the Department of Labor.

I.C.R. EQUIPMENT ORDERED.

A SYNOPSIS statement with regard to the condition of the Intercolonial Railway during the past year was recently given in the House of Commons, Ottawa, by the Hon. Frank Cochrane, Minister of Railways and Canals. The Minister said:

"The following amounts have been taken out during the year and charged to working expenses:—Rail renewals, \$100,000; fire renewals, \$60,000; equipment renewals, \$300,000. The average price for coal for the year just closed was twelve cents per ton higher than the previous year, involving an extra outlay of some \$85,000. This year I think the increase will be 25 cents a ton. The extra amount paid in wages for handling the year's business is about \$350,000 in excess of the previous year. Contracts have been let for rolling stock during the current fiscal year for over \$3,000,000 worth as follows: 45 consolidated freight engines, 5 Pacific type passenger engines, 9 switching engines, 1,423 steel frame box cars, 150 wooden box cars, 200 steel under frame platform cars, 20 steel frame stock cars, 100 Hart coal cars, 35 refrigerator cars, 100 Hart convertible Hart dump cars, 1 snow plough, 1 tank car, 7 sleeping vans, 4 dining cars, 7 first class cars, 3 baggage cars.

The stockholders of the Lozier Motor Company of Toronto, have authorized an increase in the capital stock from \$3,000,000 to \$5,000,000.

Classified Advertisements

Those who wish to sell or buy a business, obtain competent help, connect with satisfactory positions, or secure aid in starting new enterprises should not fail to use the Want Ad. Page of "CANADIAN MACHINERY."

If you want to sell or buy a second-hand lathe, planer or any other shop equipment, let "CANADIAN MACHINERY" pick out a seller or buyer for you. How about that second-hand engine or holler which you would like to offer.

Rates (payable in advance):—2c per word first insertion, 1c per word subsequent insertion, 5c additional each insertion when Box Number is required. Each figure counts as one to dispose of?

"CANADIAN MACHINERY" is the central market place of the machinery trades throughout Canada.

There is always some one looking for just such proposition as you have word.

FOR SALE

A LEFT-HAND COOPER CORLISS TANDEM compound engine, direct connected to a 200 K.W. Westinghouse generator, developing 250 volts D.C. In perfect condition, having been in use but a short time. Specifications upon request. Address The Great Atlantic & Pacific Tea Company, Box 290, New York City.

PATENTS

PIGEON, PIGEON & DAVIS

71A, ST. JAMES STREET, MONTREAL

Phone, Main 3025

16 years' experience in Canada, U.S. and Europe

TRADE MARKS, COPYRIGHTS & DESIGNS

PATENTS

LLOYD BLACKMORE & COMPANY
LUMSDEN BUILDING, TORONTO.
Also, Hope Bldg, OTTAWA & WASHINGTON, D.C.
We have an interesting and valuable booklet "PATENT PROTECTION" which will be sent free upon request.

Morton Manufacturing Co.

Draw Cut Shapers, Special Draw Cut R. R. Shapers, Special Locomotive Cylinder Planers.	Portable Planers, Stationary & Portable Key Way Cutters, Finished Machine Keys.
--	---

Office & Works, Muskegon Heights, U.S.A.

PATTERNS

WOOD AND METAL

Allow us to estimate. Satisfactory work guaranteed.

TAYLOR PATTERN WORKS WALKERVILLE, ONT.

BEATH

CRANES CHAIN BLOCKS TROLLEYS OVERHEAD RUNWAYS

Solve Coal, Machinery and Merchandise Handling Problems.
Hand, Pneumatic and Electrically Operated.

Tell us what you wish to do, and we'll suggest the proper equipment for you.

W. D. BEATH & SON, Limited
Engineers and Manufacturers

20-30 Cooper Ave.

TORONTO

System as Applied to the Shop Repairs of Locomotives

By A. H. Kendall*

The writer here sets forth in a clear and attractive manner the leading features of the very successful system followed in making locomotive repairs at the C.P.R. Angus Shops, Montreal.

A PART from the financial gain in the systematizing of a repair shop, the aim of the management is to get a team-like organization, physically and intellectually fit to perform the ordinary duties that are required, as accurately as possible, with little or no delay, and of sufficient flexibility to comply with the extraordinary conditions which from time to time arise.

The success of such an organization depends more or less upon the opportunities given to prepare to meet the requirements, and to know what the requirements are and will be with respect to anticipated repairs to locomotives, so that a staff may be trained and maintained without undue fluctuation. This may, generally speaking, be very materially assisted by the systematic shopping of engines; and the divisional master mechanic having condition records at hand at all times, should endeavor, as far as possible, to do his part of the team play by turning in for repairs each month a certain percentage of the locomotives under his control, such percentage to be that which will maintain a high degree of service.

The ideal state of affairs exists at the shop when engines are coming in for repairs in a constant flow from month to month, rather than a spasmodic shopping of, say, 5 per cent. one month and 20 per cent. the following month, and as

there is a ratio between the number of locomotives in service and the number requiring repairs each month, in order to get best results, it seems to me, from a shop point of view, that this ratio should be fixed and maintained as far as practicable, so that any system which may be set up in the shop may be carried through to the best advantage.

Repair Charts.

The repair record, Chart No. 1, shows the total repairs per month from the various shops for the Canadian Pacific Railway Eastern Lines, and embraces a period of three years. The upper line shows the number of locomotives receiving general or No. 1 and No. 2 repairs, while the lower line shows the number of locomotives receiving No. 3 or specific repairs. The straight line shows the average number of No. 1 and No. 2 repairs necessary per month to give the same total output for the three years recorded.

The upper line of Chart No. 2 shows the total general or No. 1 and No. 2 repairs per month turned out of Angus shops for Eastern lines for the same period of three years, and the lower line shows the average cost of labor per engine per month, while the straight line shows the monthly average that would give the same total output for the three years recorded. This comparison would serve to indicate the effect on the cost per engine caused by the fluctuation of output, as it shows that the higher the output, the lower the average cost, and

that the lower output would average a higher cost per engine. Other records, however, show that the repairs in January, 1911, were very much heavier on account of there being a much greater percentage of rebuilds than in May, 1910; also that this is more or less true when comparing any of the large and small monthly outputs; consequently, the great fluctuation of average cost is not altogether due to the fluctuation in numbers of monthly output.

It is, however, certain that with a more systematic shopping, which would permit of a more uniform output, following the average line more closely, the cost line would also straighten out and run more nearly parallel with the output line, and also show a very material decrease in cost for the yearly average per engine repaired.

Anticipation of Repair.

On the Canadian Pacific Railway, the general master mechanic's office prepares a monthly statement for the shop, which gives the number of locomotives expected to be shopped from each division during the following month. This report gives the classification and engine number of each locomotive, and gives a general classification of repairs, and also shows in a general way the chief cause for shopping the engine. Such a statement gives the shop a line on what to expect, and gives warning so that the necessary organization can be arranged for.

*Abstract of a paper read recently before the Canadian Railway Club, Montreal.

**Foreman of the Erecting Shop, C.P.R. Angus Shops, Montreal.

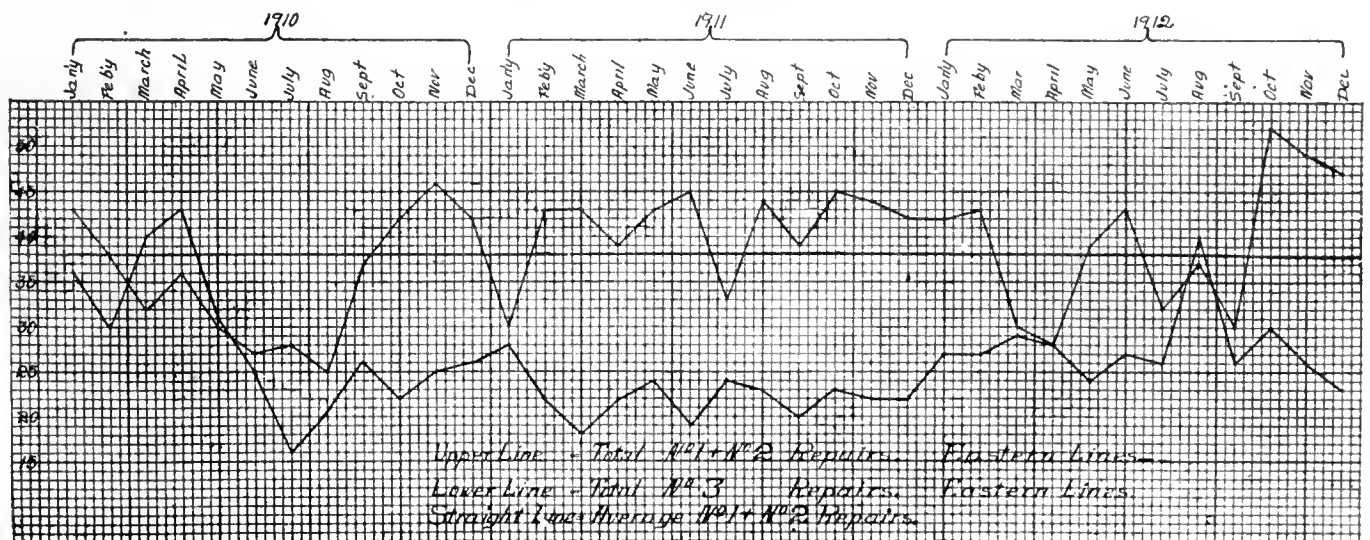

CHART NO. 1. LOCOMOTIVE REPAIR RECORD, C.P.R., EASTERN LINES.

A detailed repair report of each engine should follow this general statement as early as possible, and never later than one week previous to shopping. It should be made out by the locomotive foreman in charge, or other competent person who is thoroughly in touch with the actual condition of the engine, and should outline very clearly the exact nature of the repairs required to the machinery and boiler, so that the shop may be in a position to take advantage of this knowledge by arranging for the preparation of parts for extraordinary work of any nature. This would tend to decrease the number of days the engine would be out of service, and likewise avoid any unnecessary delay, were the shops not anticipating the requirements. Defects peculiar to actual service, which might not be found, even by most rigid test or inspection in the shop, and so pass uncareed for, should be particularized.

Attached to this repair report, or supplementary to it, should be a statement showing any missing parts which may have been destroyed by accident or have been robbed en route for "repairs to other engines," and detailing the method of shipment of defective parts, together with advice as to whether any material is being shipped or not. It should also give detailed distribution of robbed parts so as to eliminate the extra cost to the engine being shopped, due to the manufacture of parts not required, and to the manufacture of the necessary new parts to replace those robbed for other engines, and which

should be charged to the engine on which they were used.

A tool list is sent in with each engine, so that on arrival the shop hustler may check with the messenger in charge, and arrange to care for the equipment by either renewal or repairs. The shop is provided with maintenance regulation cards and manifests, governing all required repairs, and with change in progress sheets for each type of engine, which show the improvements or alterations necessary at each shopping. From these change-in-progress sheets, in conjunction with the repair report, the whole is sub-divided in detail for the guidance of each department, so that each may do their share by preparing any new parts that may be necessary, or by arranging for any extraordinary repairs that might cause delay if not known.

The superintendent's office arranges for and authorizes the necessary debits and credits due to missing or scrap material.

Systematizing.

In repairing locomotives it will be agreed, no doubt, that any system which eliminates wasted effort is good. It does not necessarily follow, however, that because any particular system has been branded as scientific that the brand alone confirms it. Conditions in different shops are so variable that an effective system adopted in one shop might be ineffective in another, consequently the best system to set up in any shop is that which, after careful investigation, will fill the required needs.

In generally considering a system from a shop point of view, it might naturally be considered as having the following features:—Cutting out lost motion and standardization of methods; regularity and uniformity of work; stimulation of workmen and co-operation or team play of all concerned, and routing material and repair parts.

At Angus shops an inspectors' or demonstrators' department takes care of the standardization of machine operations and methods, and its general function is to make a detailed study of the elements of every piece of work, for the purpose of discovering the best way of handling it, and to eliminate any unnecessary motion or work on the part of the operator, and to bring each machine up to its standard of efficiency by attaining the speed and feed which will secure the highest and best possible production, also to standardize the cutting tools to the correct angles and proportions which the experience of the past and present has proved to give the best possible results.

A portion of the Tool Dept. is set aside for the care of all cutting tools throughout the shop, and a liberal stock of all classes of standard cutting tools is kept on hand in proper condition. Each machine is provided with a standard assignment of tools, and, as tools require grinding or redressing, they are taken away by a patrol messenger, who will replace them with others, and deliver those defective to the departmental tool-dresser, if the repairs are light, and to the tool shop if the repairs are heavy.

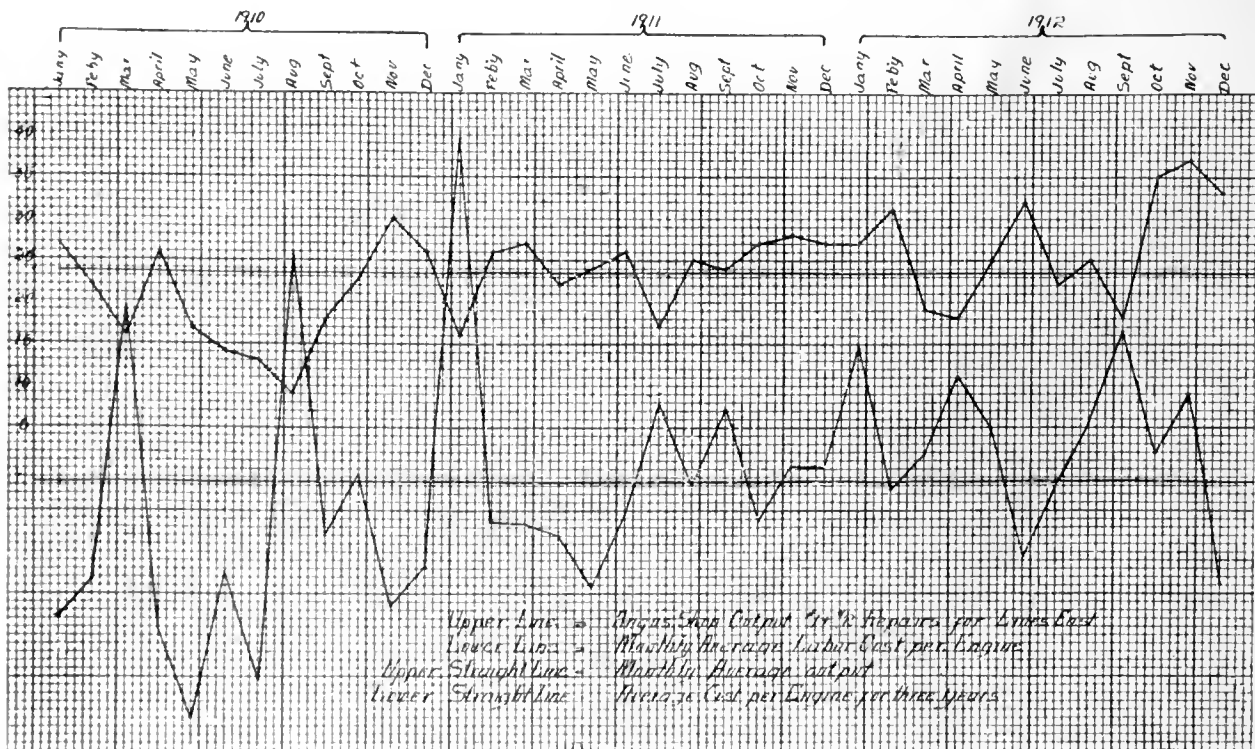

CHART NO. 2. LOCOMOTIVE REPAIR RECORD, C.P.R., EASTERN LINES.

The tool-dressers of the several departments are specialists, and their time is devoted entirely to this work, with the consequence that all tools are maintained to very nearly the limit of defectiveness. This system does away with the lost time of the machine, due to the operator having to go to a distant tool

the old hit or miss principle, or to the old time hidebound traditions which suggest we have always done it in this way and will continue to do so. The elimination of unnecessary motion in doing any work is always a benefit, because it conserves the vitality of the workman and makes his labor more productive. Apart

never lacking in stimulus and are willing to go continuously to the healthy limit, provided care is taken to supply them with work in a reasonably uniform manner, so that their efficiency results in financial gain. Consequently, it has been found that where overdraws or losses of contract money occur, it is usually due to the fact that the supply of work has not been of a sufficiently uniform character, or that work has been delayed by some other department. Where it is due to inefficiency, greater attention is given to the education of the workman, and where possible, work is assigned to him that would make him more or less of a specialist in a given line that is congenial to him. This applies particularly where it becomes necessary to employ men who are not familiar with the class of work required of them.

LOCOMOTIVE DEPARTMENT.																										
ANGUS SHOPS																										
Supt. Office <u>2-9</u> 1913																										
Foreman _____																										
Engines must leave Shop on dates shown below																										
Division	Eng. No.	Mch.	T	F	In Shop	Schedule Date Out	Machine Shops										Tender Shop	Remarks								
							X	B	M	W	R	BK	Trk	Out	Wtd	Out			Wtd	O. K.	In	Tank	Trk			
E.	1703	1	1		1-23.	2-10	X	X	X	X	X	X	X	X	X	X	X	X	X	X	X	X	X			
O.	950	1	1		1-8.	2-11	X	X	X	X	X	X	X	X	X	X	X	X	X	X	X	X	X	X		
E.	478	1	4		12-30.	2-12	X	X	X	X	X	X	X	X	X	X	X	X	X	X	X	X	X	X		
E.	523	1	1		1-14.	2-12	X	X	X	X	X	X	X	X	X	X	X	X	X	X	X	X	X	X		
O.	693	3	1		1-29.	2-13	X	X	X	X	X	X	X	X	X	X	X	X	X	X	X	X	X	X		
L.S.	3489	1	1		1-20.	2-14	X	X	X	X	X	X	X	X	X	X	X	X	X	X	X	X	X	X		
O.	754	1	1		1-3.	2-14	X	X	X	X	X	X	X	X	X	X	X	X	X	X	X	X	X	X		
E.	6184	1	1		1-15.	2-15	X	X	X	X	X	X	X	X	X	X	X	X	X	X	X	X	X	X		
L.S.	3410	2	2		1-25.	2-15	X	X	X	X	X	X	X	X	X	X	X	X	X	X	X	X	X	X		
E.	2649	1	1		1-27.	2-17	X	X	X	X	X	X	X	X	X	X	X	X	X	X	X	X	X	X		
A.	545	1	1		1-23.	2-18	X	X	X	X	X	X	X	X	X	X	X	X	X	X	X	X	X	X		
L.S.	3434	3			2-7.	2-18	X	X	X	X	X	X	X	X	X	X	X	X	X	X	X	X	X	X		
O.	2694	1	1		1-24.	2-19	X	X	X	X	X	X	X	X	X	X	X	X	X	X	X	X	X	X		
L.S.	2580	1	1		2-4.	2-20	X	X	X	X	X	X	X	X	X	X	X	X	X	X	X	X	X	X		
E.	298	1	1		1-23.	2-20	X	X	X	X	X	X	X	X	X	X	X	X	X	X	X	X	X	X		
E.	647	1	1		2-5.	2-21	X	X	X	X	X	X	X	X	X	X	X	X	X	X	X	X	X	X		
O.	370	1	1		2-5.	2-21	X	X	X	X	X	X	X	X	X	X	X	X	X	X	X	X	X	X		
E.	1756	1	1		2-6.	2-22	X	X	X	X	X	X	X	X	X	X	X	X	X	X	X	X	X	X		
E.	1505	1	1		2-3.	2-24	X	X	X	X	X	X	X	X	X	X	X	X	X	X	X	X	X	X		
A.	3525	1	1		1-25.	2-25	X	X	X	X	X	X	X	X	X	X	X	X	X	X	X	X	X	X		
O.	6162	1	1		1-8.	2-26	X	X	X	X	X	X	X	X	X	X	X	X	X	X	X	X	X	X		
E.	3527	1	1		1-28.	2-27	X	X	X	X	X	X	X	X	X	X	X	X	X	X	X	X	X	X		
O.	325	1	1		1-20.	2-27	X	X	X	X	X	X	X	X	X	X	X	X	X	X	X	X	X	X		
L.S.	3363	2			2-12.	2-28	X	X	X	X	X	X	X	X	X	X	X	X	X	X	X	X	X	X		
E.	552	1	1		2-13.	3-1	X	X	X	X	X	X	X	X	X	X	X	X	X	X	X	X	X	X		
O.	113	1	1		2-4.	3-3.	X	X	X	X	X	X	X	X	X	X	X	X	X	X	X	X	X	X		

GENERAL PROGRESS SHEET—LOCOMOTIVE REPAIRS, C.P.R., EASTERN LINES.

room to exchange a defective tool, or by waiting his turn at the grindstone or emery wheel to make the repair.

Detail Operation.

In considering the subject of Detail Operation, it seems to the writer that the leader or officer who sneers at the mention of motion studies, is very far behind the procession of to-day, and very likely this same man would cross corners to take a short cut home, or kick at a car transfer point, when the connection is not made promptly.

There is an easiest and quickest way to perform every work operation on a locomotive repair, and that is what we should be out to find by the application of deliberate and diligent study, by analyzing the methods of various other shops, and by the comparison of operation with operation and results, with those of other roads, instead of leaving the workmen to

from the machine operations, it is the duty of each foreman to observe the habits of his workmen with a view to correcting any improper methods and removing any unnecessary motion in his work. This is particularly true where inefficient men only are obtainable to do skilled work, it being necessary to study their movements in order to train them to that standard of efficiency which skilled men have already attained.

Piecework The Stimulus.

A straight piecework system is adopted at Angus as a stimulus to the workmen, by which means an efficient worker is able to increase his earning capacity considerably above his day rate without fear of overstrain, providing he apply himself diligently to his duty, and that he is supplied with continuous work. General experience indicates that the average mechanics of to-day, are

Spirit of Co-operation.

A hearty spirit of co-operation is maintained throughout the works between the working force and the management, by continued effort on the part of those in charge to deal with the workmen in an open, frank and candid way, affording fullest opportunity for consultation and explanation, in advance of any action which may materially affect their interest. To further the development of esprit de corps amongst the workmen, the management have fostered and instituted a Scientific and Literary Association, and an Amateur Athletic Association which embraces nearly all competitive sport common to our country. These societies are controlled and managed by the employees themselves, and have become a powerful link in uniting all grades in a common interest. They have done much good in this respect, as well as by physically developing the younger men and others who may be in need of such, to further fit them for the duties they are required to perform through life.

Routing.

The routing of work in all large shops is a very live subject, and is one that may either cause a great deal of annoyance or otherwise, dependent on the method adopted and carried out. The routing trouble at Angus has been more or less overcome by the careful grouping of machines, so that as far as it is practicable, all work required on any particular part will be done within as small an area as possible, and under the same leader. Where it becomes necessary for work to go to more than one shop, the foreman who last handles a part is responsible for its delivery to the next in order, and where delay occurs, it is shown up quite clearly by the Material Chasing Schedule or the Work

Order System, which is taken care of by a scheduling department.

Scheduling Repairs.

The duty of the Schedule Department is to provide each department each day with a detail of all work required from them for the day, and to show up clearly to all in charge, any work or operation which may require particular attention on account of it being neglected or held up for lack of material. This information is taken from and governed by a Master Schedule or Key, which was drawn up some years ago, and which has been more or less revised after careful and intelligent consideration to meet the requirements of Angus Shops. It is, generally speaking, an up-to-date common-sense system of material chasing.

On arrival at the shop, the inspection staff, who should have already been supplied with an outside repair report, go over the engine in a general way, and any work which may be of a doubtful nature in accordance with the report is forthwith dealt with, and any further material required is immediately ordered. When the engine is shopped, the classification of repairs having been thoroughly decided, the stripping gang, who are specialized in this particular branch, remove first, all parts which are necessary to permit of further inspection or test.

Testing and detail inspection is then made, and orders issued for the balance of the stripping, which is based entirely on the individuality of the engine being stripped. Indiscriminate stripping should not be tolerated, and care should be taken that no part is removed unless it requires attention or must be removed to permit of repairs to some other part. The chargineman should pay particular attention to the recording of all parts requiring repairs, especially the detail, or those parts which are usually considered unimportant, so that every piece which is for distribution or renewal will be duly ordered on the Schedule Office, which in turn orders on the various feeder shops, so that continuous record of its progress through the shop may be obtained at any time and duly entered on the morning operation sheets, thereby ensuring proper attention being applied towards having it returned in due time along with the more important parts for assembly.

General Progress Sheet.

A General Progress Sheet, as illustrated, is supplied to the management of the shop. This shows, in very compact form, the general nature of the supply. It is kept fully posted by being checked daily with the operation sheets, so that delinquents can be located at a moment's notice, without the necessity of referring to the detail operation

sheet. This sheet shows the engine number, classification of repairs, the division to which the engine is assigned, and the date on which the engine is taken into the shop and expected out, as also a resumé of all work which has been completed. The letters above the several columns under machine shop represent the parts—guides and cross-heads, boiler mountings, spring and gear, motion and valves, wheels, main and side rods, brake gear, engine truck—while the tick mark is merely an abbreviated method of showing that the work is finished.

General Operation and Delay Sheet.

A general operation and delay sheet is also supplied the management, and shows all material due to erecting shop, as well as any material which may be late. It gives the cause for delay when possible to do so, thereby directing immediate attention to the seat of the trouble, so that steps may be taken at once to rectify the latter, usually without further investigation.

By this means of checking material and work orders, there is no chance of failure of organization in any particular branch of the shop, as the unit which may be lagging can be straightened out at will, and brought to the required efficiency without any elaborate or delayed investigation, by merely comparing the piece work balance to see that the man efficiency is not falling behind. This, if carried out, will bring about a well balanced team or organization, and get away from the contingency of any one feeder shop falling down and dragging the whole organization back with it.

In considering the schedule it should be remembered that it is better to have finished parts remain unused for one or even two days than to have the Erecting Shop delayed half a day for the want of them. For this reason, some latitude should be allowed to overcome those little hitches which occur even in the best regulated families, and as "the best laid plans of mice and men gang aft agley," it may be necessary, on account of some ungovernable delay, to make a very short schedule for one or more engines, to keep the output up to requirements. A change might also be necessary at any time to meet the urgent or extraordinary cases which occasionally occur on account of road conditions.

In the case of heavy boiler work, the boiler is removed from the frames as per schedule and carried to the Boiler Shop. All other material is loaded on the frame and put out in storage until a certain stage is arrived at in the repair of the boiler at which point the engine is again brought into the shop and the stripping completed, so that all ma-

terial may be delivered to the feeder shops for repairs at the correct time. This allows the work on all parts to progress in harmony.



GROWTH OF MEDICINE HAT.

A MEDICINE HAT paper gives statistics of the city's growth as follows:

Industries in Operation.

Industries	Investment.
Alberta Clay Products Co	\$500,000
Medicine Hat Milling Co	200,000
Alberta Linseed Oil Mills	50,000
Alberta Iron Rolling Mills Co.	150,000
Alberta Foundry & Machine Co.	60,000
Preston Planing Mills	50,000
Rosery Flower Co.	50,000
Western Cold Storage Co.	150,000
Kaiser Cigar Co.	10,000
International Supply Co.	25,000
Medicine Hat Steam Laundry	30,000

Plants Under Construction.

Industries.	Investment.
Ogilvie Flour Mills	\$1,000,000
Alberta Porcelain Co.	150,000
Alberta Pottery Co.	150,000
Alberta Glass Bottle Co.	85,000
Medicine Hat Crayon Co.	75,000
Medicine Hat Pump and Brass Manufacturing Co.	50,000
Wetaskiwin Tent & Mattress Co.	30,000
Alberta Steel Products Co.	15,000
Medicine Hat Grain Bin Co.	25,000
Medicine Hat Bottling and Extract Manufacturing Co.	20,000
	<hr/>
	\$1,600,000

Industries About to Locate.

Industries.	Investment.
Canada Cement Co.	\$1,250,000
Prince Albert Iron, Paint & Wood Co.	1,000,000
Maple Leaf Milling Co.	800,000
Manitoba & Ontario Mills	800,000
Medicine Hat Steel Co.	250,000
Alberta Saskatchewan Paper and Strawboard Co.	150,000
Wright Radiator Co.	100,000
Saskatchewan Iron & Bridge Co.	100,000
Medicine Hat Concrete Products Co.	25,000
Tabor Candy Co.	35,000
Matthews & Streight, Metal Windows and Fire Doors	4,000
Hunt Cement Co. (just outside city limits)	1,000,000
	<hr/>
	\$5,264,000

The estimated pay roll of the industries under construction and about to locate is \$2,000,000 and the employees about 2,000.

Typical Methods of Attaching Chucks to Lathe Spindles*

By Fred Horner

The manner in which a lathe chuck is attached to its spindle has a vital influence upon the accuracy of a considerable portion of the work which is turned and bored in a lathe. Again, numerous adaptations of chucks purchased from manufacturers are required to suit individual cases. The article deals with the principal points involved.

AS previously noted, the inside of the spindle is utilized in certain instances to the exclusion of the outside of the nose, but in some designs both are brought into requisition. The most primitive kind of attachment, still used largely in brass-finishing lathes, is the screwed hole, the tail of the chuck or

wear, it is not surprising to find the method applied in a variety of ways. The most familiar examples are the taper arbors for drill chucks, and the split wire chucks. The former, Fig. 17, are used in all small drill chucks, if it be not necessary to pass a rod right through. Should this be essential, then

may be utilized to secure the taper chucks or the arbors. For example, the arbor, Fig. 18, is pulled into place by the draw spindle, and the taper projecting end receives drill or other chucks, or it is threaded to carry small face-plates, or has a nut and washers to hold grinding wheels, saws, cutters, etc.

The familiar split draw-in chucks are also arranged similarly, being made with three cuts, Fig. 18 (B), and closed-in by the action of the tapered shoulder. When a larger diameter has to be held, resort must be made to the split step chucks, which being too large for closing by the spindle itself, must be supplemented by an adapter or closer, Fig. 19 (A). This consists of a hollowed body fitting on the outside of the spindle, either by a taper as shown, or by threads. The miniature view (B), in the same Fig. shows the construction of a closer and chuck for smaller diameters. In lathes with a plain external taper to the nose, the face-plates and chucks may also be held and driven by the taper, a draw-in rod being secured to the chuck to put it on to the nose.

Other Forms of Split Chuck Fittings.

A push-out chuck necessarily requires a closer, extra to the spindle; in small diameters, a closer of the type illustrated in Fig. 20 is commonly employed. It will be noted in this example that the closer fits on plain parts of the spindle in front of and behind the screw thread, ensuring a very accurate fit and true running. Turret lathe spindles formed with an enlarged hooded end require an extra ring to be screwed in, Fig. 21 (A) for the coned diameter of the split chuck to fit, and the same is also the

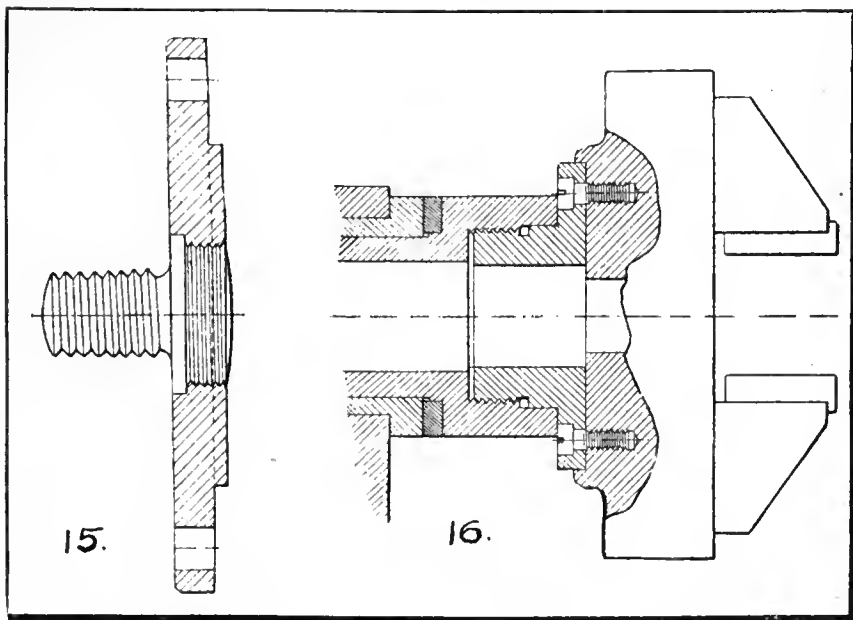

FIG. 15. FORGED ADAPTER PLATE WITH SCREWED TAIL.

FIG. 16. ADAPTER SCREWED INSIDE SPINDLE NOSE.

of the adapter being threaded to correspond. If the adapter must be of the face-plate type to serew to the chuck, a built-up arrangement is made like that seen in fig. 15, having a cast-iron plate, the mild steel tail being screwed in and riveted, or the plate and tail formed in one mild steel forging.

With the larger hollow spindle built for turret lathes, there is a chance to obtain a better and more workmanlike fit between the spindle and adapter than is the case with a small screw. Fig. 16 illustrates a case in point; a short length of plain bore being left in the spindle, and the adapter fitted to this, thereby ensuring better concentricity. In designs where the adapter has thicker walls, the chuck screws may, instead, be passed in from the front.

Chucks Fitted Inside Spindles With Tapers.

As a taper fit inside the spindle ensures concentricity notwithstanding

the taper shank cannot be employed. Either a plain arbor is made in the case of the chuck shown, or preferably, a nut is put on between spindle and chuck, so that the taper may be disengaged from either by turning the nut. In the smaller lathes and in bench lathes or other special kinds, the draw-in device

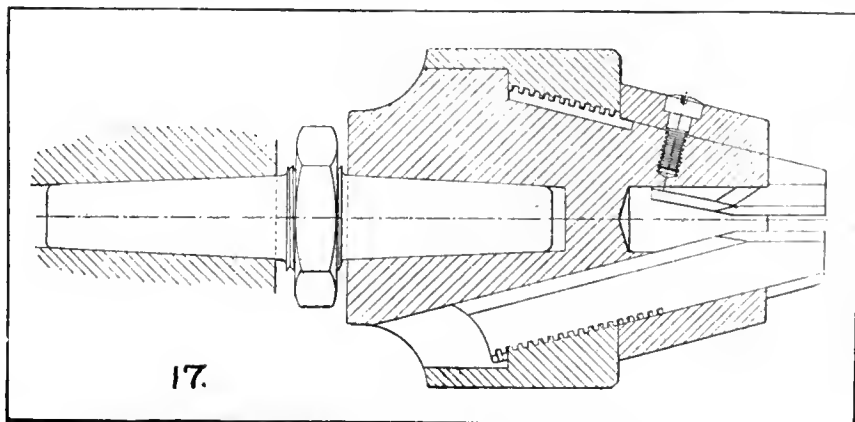

17.

FIG. 17. TAPER SHANK FOR DRILL CHUCK.

*"Pages Weekly."

ease if the hood is separate and screwed on as at (B). The hood usually takes its shoulder bearing against the front end of the spindle instead of against a flange, when the spindle is minus the latter. The two collets in these views are of the "master" type, being adapted to receive a variety of collets for differing sizes and shapes of work, instead of fitting a separate solid collet for each, which would multiply the cost and weight of the equipment. The collets are attached to the master collet by screws, either laterally as seen, or put in

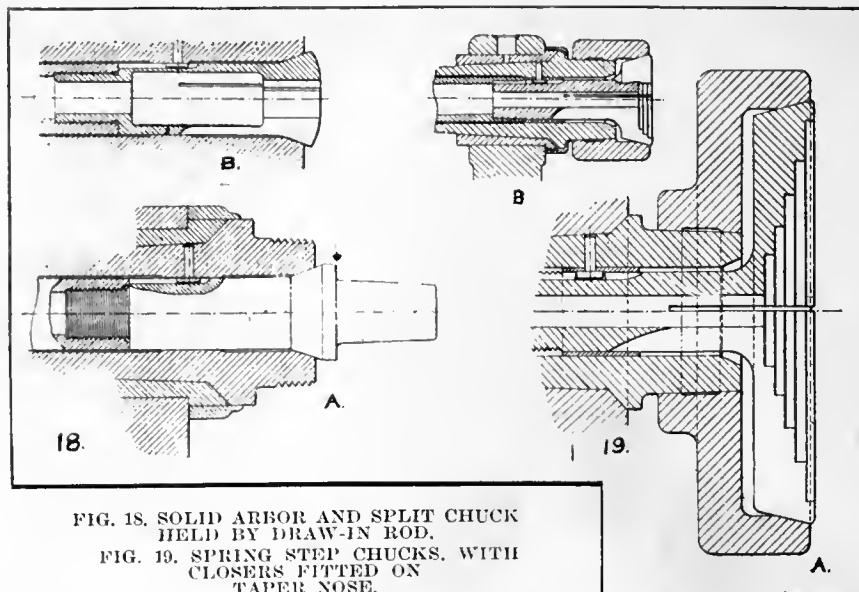

FIG. 18. SOLID ARBOR AND SPLIT CHUCK HELD BY DRAW-IN ROD.

FIG. 19. SPRING STEP CHUCKS, WITH CLOSERS FITTED ON TAPER NOSE.

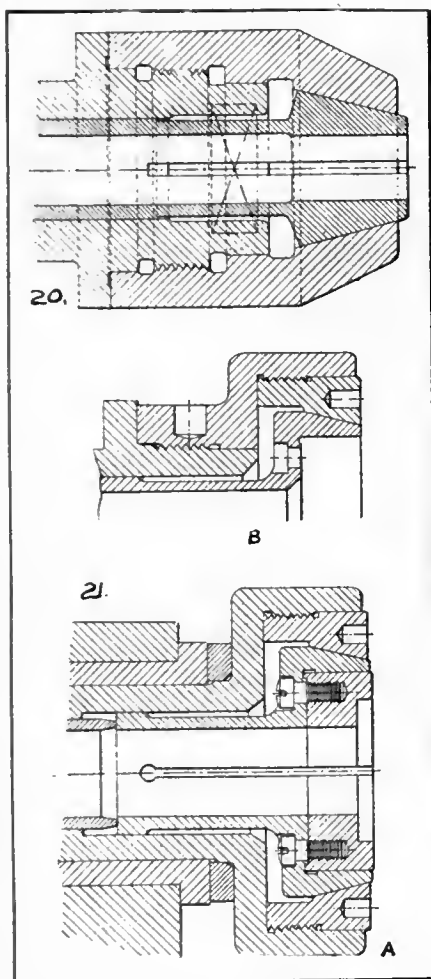

FIG. 20. SHOWING CLOSER FOR PUSH-OUT CHUCK OF SMALL DIAMETER.

FIG. 21. MASTER COLLETS FITTED TO SPINDLE BY ADAPTER RINGS.

radially from the outside. A great many variations might be illustrated of the modifications in these split chucks, but these would be outside the scope of this article, as the purpose is not to deal with variations in chucks proper, but only the principles involved in their attachment. Fig. 22 represents the mode of fitting the chuck in open-spindle and similar capstan lathes.

Means Adopted for the Removal of Chucks From Spindles.

When the power of the hands alone is not enough to effect the removal of a

chuck which has jammed tightly on its spindle, some kind of spanner must be employed to gain the necessary leverage. If it is possible to get a couple of flats of good area on the boss of the chuck or its adapter, a large spanner can be applied. Messrs. Charles Taylor; Ltd., of Birmingham, pursue two methods with the adapters, one being to slot the rim of the flange to receive a hooked spanner, Fig. 23 (A). This is

followed in the case of stamped steel adapters. For the cast iron backplates, bosses are cast on the back (B), and holes are drilled to receive a podger. Either two or three bosses are cast on, so as to run in balance.

If frequent removal of an adapter is necessary or a chuck hood has to be changed frequently the metal in the hole becomes compressed and the hole gets too large.

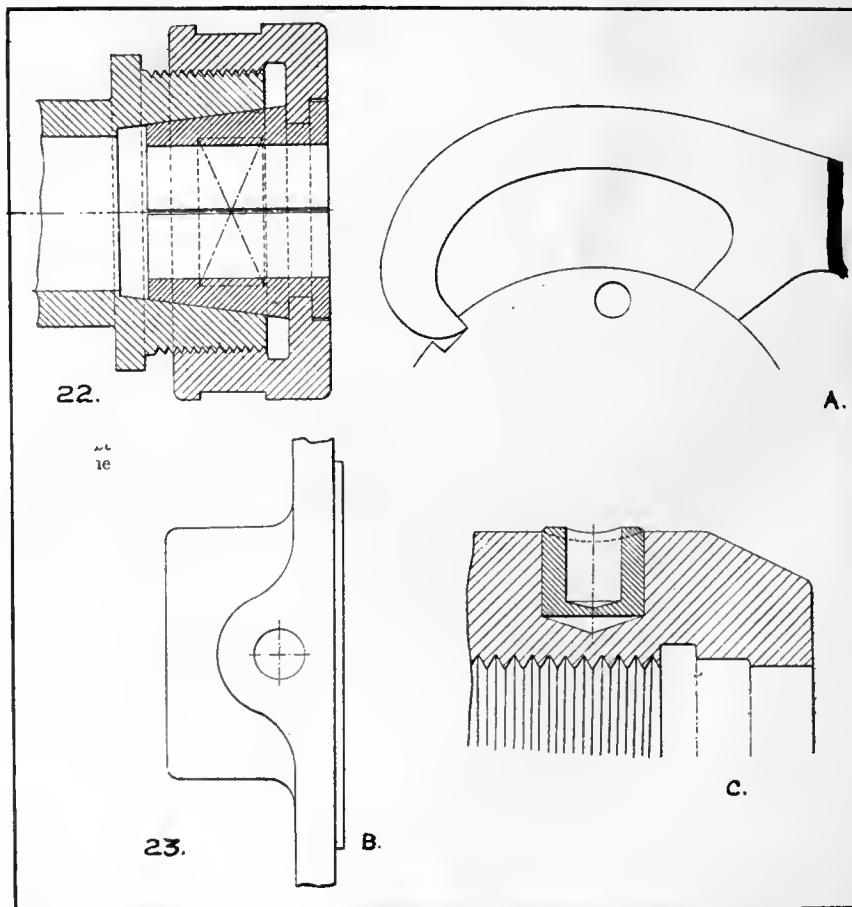

FIG. 22. LOOSE GRIPS CLOSED BY TAPERED SPINDLE BORE.

FIG. 23. DEVICES FOR REMOVAL OF CHUCKS.

The Belt Drive as a Factor in Power Transmission Work*

By R. Berry

That the Belt Drive occupies a leading place, and does not apparently lose much ground through the introduction of other mediums for the transmission of power, is quite apparent to those who labor in factories, and to those whose business gives opportunity of becoming familiar with conditions in manufacturing plants of widely varying product. The very fact of their large and universal adoption makes necessary that those responsible be thoroughly conversant with their arrangement, care, treatment and capacity.

IN dealing with transmission of power by belting, I wish to include leather, canvas, rope, gut-cord, and steel band drives, giving as far as possible the merits and demerits of each method.

Inaccurate Standard Tables.

A pamphlet compiled by a gentleman who is credited with being an authority on the subject, gives a table to show that the output of a belt solely depends on diameter of the pulley on which the belt is running, and that velocity does not count. It is unfortunate that such tables get into print, and more so, as other writers, because he is credited with being an authority, have copied this same table into their books. I have several well-known authors' books containing the same misleading tables. It is quite evident that the compiler never tested it in a practical manner, or he would have discovered his mistake. However, such tables should be obtained by practical experience.

The table says that a 1 inch single leather belt, running upon 6 inch pulleys at a belt velocity of 6,400 ft. per minute, will just transmit 1 h.p. of work. Let us see how far this holds good. In the first place, providing pulleys are not very small, say, not less than 6 inches, from my own experience, the diameter has little to do with output, which depends on velocity and co-efficient of friction. Assuming there are no other losses, such as centrifugal force, etc., a 1 inch single leather belt at a velocity of 6,400 feet per minute would safely transmit 9 h.p., which is a vast difference from what the table shows. Under these conditions, the working tension per inch width equals 46 lbs., which is not by any means excessive.

Material for Belt Drives.

An engineer is frequently asked what kind of belt material he would recommend for a certain class of work. To determine which is the most suitable, leather, cotton, canvas, or rope drive, a proper knowledge of the surroundings is necessary. The first thing is to ascertain the atmospheric conditions where the drive is intended to be. In a very heavily saturated atmosphere, such as steam or damp, leather is positively use-

less, because water dropping on the working face of such a belt will cause instant slipping if it is working at anything like its full capacity.

On the other hand, moisture on cotton, canvas, or even rope drives may prove beneficial. I have seen canvas, cotton and rope drives working right out in the open and during slight rain-falls. Leather in such weather would not keep to the pulley many minutes, even under half-load. For moist atmospheres or outdoor work, cotton, canvas, or rope is preferable, but in warm, dry atmospheres (indoor, of course), good leather is far superior to either cotton, canvas, or rope. Canvas and cotton belts, if working in a very warm, dry shop, soon acquire a glossy surface and the pulley face becomes bright, which is a sure sign of slipping and loss of power. Again, leather, if properly cared for and treated with suitable dressing, may run for years with but little trouble.

Care of Belts.

The attention that belts usually receive, largely depends on the class of work. If at a soap works, they may get an occasional rub with a bar of soap, or in a printer's works a few dabs of printer's ink, and in a cabinet maker's shop a swipe with a glue brush. In a drysalter's works a lump of dry resin is thrown in between pulley and band, and is immediately crushed, part of it sticking to the band and the other part distributed along the whole length of band race. On the other hand, some men take quite a pride in their larger belts and brush them down every week end and also occasionally apply a suitable dressing; one went so far as to scrub his main belts and give them a dressing of castor oil every holiday. Such care lengthens the life of the belt and improves its capacity for work.

Belt Sides.

We are fond of running belts with the soft or fleshy side nearest the pulley face, but in the United States you will see belts running with the smooth or hair side near the pulley. The hair side has a greater co-efficient of friction, and, consequently, better pulley grip than the fleshy side, although life of the belt will be somewhat shorter if

so used. I favor the hair side being on the pulley, for better grip and improved efficiency. It is well known that practically all the strength of leather is in the hair side, it being possible to cut 40 per cent. of the flesh side away, without materially reducing the strength.

Iron bolts and copper rivets are best left out of any belt, because when passing over the pulley they reduce the grip considerably just at the moment, and if driving a dynamo or motor will cause a slight sparking at commutator every time they pass. I always avoid belting that is stitched together with copper or other metal wire, although it is true that a belt stitched with wire is very strong, yet strength is not so important as adhesion. The properties of an efficient belt are:—Reasonable tensile strength, say, 3,000 lbs. per sq. in., high adhesive quality, free from elasticity, great flexibility, homogeneous throughout, and not greatly affected hygroscopically.

Power and Speed.

If troubled by a belt constantly slipping, even though tightened to the maximum tension the bearings and shafting will stand without seriously heating up, it will not materially help matters to lengthen the distance between centres of shafts or to increase the width of belt or put on thicker material or double leather. None of these will be of service without a corresponding increase in tension, and that already is prohibited by the bearings. The only way of getting over the difficulty is to increase the velocity of the belt by larger diameter of pulleys or speeding up the shafting; this will secure better results with a reduced tension upon the bearings and shafting.

I advocate keeping up the speed of belting, and there is good reason for doing so. A 10 inch single leather belt running at 70 ft. per minute under good conditions only transmits 1 h.p.; if speeded up to 5,000 ft. it would, for the same total tension, transmit 70 h.p. These are extreme cases, but any belt will stand a speed of 3,000 to 4,000 ft. Machine tool designers would do well to bear this in mind. You have heard the screeching or squealing made by the belt changing over from one pulley to the other on a planing machine at each

*From a paper read before the Birmingham Association of Mechanical Engineers.

reversal, and can readily conceive the shock and heavy torsional stresses the whole gear is subjected to and the heavy gulp of energy absorbed at each reversal.

With an electrical drive it is easy to measure this, and I have several readings which show at times more than treble the amount of energy absorbed at reversal than required for the heaviest cut. This is when the table is changing from cutting to return stroke, often at the rate of 140 ft. per minute. The average width of a planing machine belt is anything from 3 in. to 6 in., and often of double leather. On very large machines, I have known 8 in. double leather used. If it were possible (and I fail to see why it should not be) to increase the belt velocity three or four times, you would only require a belt quarter the width to perform the same work: in place of the 6 in. belt, a 1½ in. belt would do.

The output of any belt material varies directly as the velocity or speed. I can instance a very large planing machine driven with a 3 in. double leather belt, and the drive is very successful. The machine has a 24 ft. table, which weighs 19½ tons, and is capable of displacing, with four tools cutting, 11 cwt. of metal per hour—and all this with a 3 in. belt. Another planer, 6 ft. by 4 ft. by 4 ft. is driven by a 1¼ inch double leather belt, running at 5,000 ft. per minute (equivalent to a 6 in. belt running at 1,200 ft. per minute). This is far better than the old method of wide belts and comparatively slow speeds. The second machine has been running four years and has given little trouble. The narrow belt easily passes from one pulley to the other, and when doing so, is practically free from squealing.

Engine and Dynamo Speeds.

Fully twenty years ago I argued with engine builders and dynamo makers about keeping the speed of engines up and dynamo revolutions down, with a view to reducing the ratio in speed. At that time, low-speed dynamos were unheard of; the general run of either dynamo or motor would be (for machines up to 10 h.p.) 1,200 to 1,800 r.p.m., and in exceptional cases as high as 2,500 revolutions, while only generating a comparatively low voltage of 50 to 60 volts. The much larger dynamos would be running at 700 to 900 revolutions, but rarely below 700, and in almost every case driven from the fly wheel of the engine, generally of the slow-speed type; so that it was common to see a large ratio in diameters between driver and driven pulleys, frequently 6 or 8 to 1, with the result that any slight fluctuation on the engine would be multiplied on the dynamo, causing a constant flicker throughout the lighting circuit.

To remedy this defect, several electrical and mechanical contrivances were devised. Engine builders began to increase the weight of fly wheels, and on gas engines frequently, two fairly heavy wheels were fitted, one on either side of the engine.

The Largest Belt.

The Chicago Belting Co. have made a monster belt; length 150 ft., width, 7 ft., weight 3,300 lbs., thickness 7/8 in. Selected portions of 450 oak-tanned hides, picked from over 5,000 skins, entered into its construction. It is used in the engine room of the Louisiana Electric Light Co., at New Orleans, attached to the 28 ft. driving wheel of an Allis-Corliss engine. It is generally believed that this belt is the largest ever made.

Tensile Strength.

The average tensile strength of ordinary leather belting equals 3,000 lbs. per sq. in., that of rope being about 20 per cent. higher. I do not attach much importance to this, because the breaking strain of any belt material ought to be quite a secondary consideration, as the working tension is always a small fraction of the breaking strain. A belt of high tensile strength, but with a correspondingly low co-efficient, although very strong, will be a poor transmitter of energy.

In the early days when power-driven lathes were unknown, catgut bands were almost always employed for transmitting motion from the foot wheel. The great strength and long wearing qualities of catgut make it a material unapproached by any other for the purpose; yet, seemingly, with the advent of power-driven machinery, its value as belting material has largely been lost sight of.

As catgut will work efficiently under a tension of 2,700 lbs. per sq. in., or about five times that of leather, and for long periods, it is obvious the material is good for something else besides violin strings. Owing to the better co-efficient of gut cord in a grooved pulley, for certain machinery, it should prove more profitable than leather or other material. I remember a round gut cord band ¾ in. diameter running at 5,000 ft. per min., and transmitting 40 h.p. on an eight hours' trial run, which would be equivalent to 3,000 lbs. per sq. in. for working tension. The objections to the use of gut belting is its heavy first cost, susceptibility to weather, and the difficulty of making a good and flexible joint.

Steel Belts.

We hear a great deal about steel belts running on rubber or cork-faced pulleys. Professor Kammerer, of Berlin, makes great claim for these, and shows

some remarkably good results. I fail to see any great advantage in such high tensile material, and feel that the consequences might be very serious if a long steel belt, very much like a band saw, only considerably wider, longer and heavier, should break. Just imagine about 200 ft. of this steel snapping and becoming entangled with the revolving machinery, coiled up and being swerved round at a velocity of two miles per minute. On one of his illustrations he shows two steel belts, 150 mm. wide, 0.7 mm. thick, transmitting 450 h.p., replacing twelve hemp ropes. A good steel may have a tensile strength of twenty times ordinary leather, and a steel belt 1 in. wide would do the work of a single leather belt 20 in. wide, yet, assuming it does, I cannot see any real advantage.

In the first place, if one material is twenty times stronger than another we increase our working tension by the same ratio; the factor of safety is practically the same, and pressure per sq. in. of surface made by the steel belt on rubber-faced pulley must be enormous, and one that would soon cut a deep furrow in the composition. Again, a steel band running on a rubber-faced pulley cannot possess a better co-efficient of friction than a rubber or cork-faced belt running on an iron-faced pulley, so that the only real advantage is that the space occupied is narrower, also pulley faces. He shows belts traveling at 10,000 ft. per min. and for pulleys, however carefully balanced, that is a dangerous speed.

Stretching and Creeping of Belts.

It is usual to assume that the number of revolutions of two shafts connected by a band is inversely as the diameters of both driver and driven pulleys, and for most purposes it is perhaps safe to accept it as such, although, strictly speaking, it is not quite true, because when a belt is doing work, the tight or working side will be constantly stretching considerably more than the slack side, the amount depending upon the elastic properties of the material in the belt and the working tension on it. Consequently, the pulley and shaft which are being driven will fall behind in speed by an amount equal to the excess of extension. For instance, it has been shown that by using a very elastic belt the driven shaft was only running about half-speed of the driving shaft, although both pulleys were practically the same diameter. The creeping effect which is constantly going on will also tend to increase this lagging behind of the driven pulley, which is also increased by the longer distance between pulleys, although there may not be any slipping, in the real sense of the word.

The creeping effects of belts is often spoken of as being a legitimate effect of lagging behind, which is an actual loss of power, and one that unfortunately cannot be avoided, either by means of belt tighteners, belt compounds or solutions, or patent pulley coverings. It is due to the band undergoing compression and tension every time it passes over the pulleys, and cannot be prevented by tightening up the belt; therefore it does not represent the usual slip with slack belts. With good material, the creep should not exceed 1 per cent., whilst the slip due to unequal stretching between tight and slack sides of belt should not exceed $1\frac{1}{2}$ per cent. Therefore the total lagging effects upon a properly designed belt drive should not be more than 2 to $2\frac{1}{2}$ per cent.

Double Leather Belting.

Avoid double leather belts as much as possible, especially where the pulleys are small in diameter. The chief reason for using these is to cover up some poor design of machinery, where it is found necessary to employ a heavy tension per inch in width in order to get the belt to fulfil its requirements. This heavy tension will sooner or later tell its tale upon bearings, shafting and loose pulleys. If a belt gives trouble by constantly slipping, better by far increase the velocity by increasing diameter of both pulleys if possible, for by doubling the velocity, the belt will give a double output in energy transmitted, without the slightest increase of pressure upon bearings.

The weight of a belt should be as little as possible, consistent with the power to be transmitted; this not only saves power in keeping the belt itself in motion, but reduces the centrifugal action that tends to keep the belt from coming into proper contact with the pulley face, especially at very high speeds. When a double leather belt is passing round a small pulley at very high speed, the belting is pulled away from the pulley face several degrees, due to the inflexibility of the belt, and if the arc of contact is as important as we are led to believe, then discourage the use of double leather or any other heavy, thick belt material.

It is not always possible or convenient to obtain a high velocity of belt speed without practically re-designing the machine, and often machine makers put on pulleys far too narrow and too small in diameter, to allow of a suitable belt being fitted. In such cases, there is no help for it but to put on a double belt, or even compound it by putting on a second belt the same width, to ride on top of the original one. Either case puts an excessive tension on the bearings. If both pulleys are large in diameter, say

4 ft. or 5 ft., there is not much harm in using double belting.

Convexity of Pulleys.

Engineers are generally agreed that pulley faces should be rounded, but to what extent, they do not agree. It is no uncommon thing to see a band running on two pulleys with a wide difference of roundness, which is very injurious to the band, especially where dry resin is freely used. Diameter should not have any relation to convexity, this being solely controlled by the width of face. In order to adopt some universal method, I suggest:—

Square the width of face in inches, and add 10 to the result, and take this as the radius for striking the arc of convexity, from which sheet steel gauges could be struck, made and kept by for use. As example, take a pulley with a 6 in. face, then $6 \times 6 + 10 = 46$. This should be the radius for striking the arc. Or, again, a pulley 4 in. face: $4 \times 4 + 10 = 26$ in. radius. This method I have used for many years, and proved it satisfactory for any width of pulley.

Arc of Contact.

There is no doubt that as you increase the arc of contact, embraced by real direct tension, you must obviously increase the gripping power of the belt, but to increase the arc of contact by idlers, jockey pulleys, or having slack side of belt on top, I consider to be a very poor way of obtaining one's object. It has always been a mystery to me why engineers should put down slow revolving engines or main shafting to drive high-speed machines, then, owing to the great ratio between two pulleys, resort to idlers or jockey pulleys, placing them near the smallest pulley for the purpose of increasing the arc of contact.

If the machines to be driven are of necessity high speed, speed up the driving shaft or put down high-speed engines, gas, oil, steam or even steam turbines, and either couple up direct, or, if it must be belt drive, design to have pulleys of equal diameter or thereabouts, but certainly not more than 4 to 1 ratio. In the case of dynamo driving, it is possible to obtain low speed dynamos and high-speed engines which will give pulleys, both driver and driven, the same diameter, then with such, you obtain the very maximum arc of contact possible for a straight belt without jockey pulleys or idlers.

Long Drives.

You cannot hope to materially increase the working capacity of a belt otherwise than by velocity, improving the adhesive effects, or increasing total tension, but it matters little whether total tension is increased by actually tightening the belt or produced by the sagging of

the long heavy belt. In many cases the engineer in charge, for the sole purpose of obtaining long drives, has a machine at one side of the shop and countershaft at the other, taking the first belt from line shafting across the whole width of shop to countershaft, and then a second belt again across the shop to machine, which, to say the least, is overdoing the thing, in addition to the waste of belt material.

I am not advocating very short drives with narrow and excessively tight belts. I recommend keeping the belt velocity fairly high, say, up to 4,000 ft. per minute where possible, and so reduce both width and weight of belt, and give shaft and bearings the chance to live a long life without making a lot of trouble. Take total circumference of both pulleys to represent distance between centres of shaft, whatever the diameter of pulleys may be. Such distances, to my mind, give sufficient flexibility and room to turn in without waste of belt material.

Mr. Halliday, in his book on "Belt Driving," says:

"Of all the ways by which a belt may be made to drive more, giving it great tension may be regarded as the poorest all round. Give it more arc of contact, give it better pulley surface, increase the width and thickness, which will increase the output; do almost anything except to increase the tension." He says "do anything but increase the tension," and at the same time put on a thicker and wider belt. What for? What are the virtues of double leather? The grip of a double leather belt is no better than that of a single one, unless the tension is increased either by the heavier belt or by tightners, or other means. The effect on life of shafting, bearings and loose pulleys will be the same whether the increased tension is due to a heavier belt or tightness.

My advice is:—Don't use double leather in any case where it can possibly be avoided. There is no reason for doing so, except to employ a greater tension on the pulley face and between the two shafts, which tends to considerably reduce the life of shaftings, bearings and pulleys.

Belt Grip.

The grip of belt is quite independent of the area of contact and it is also immaterial whether the surface is flat or curved, so long as it is uniformly curved, such as a pulley face. To test the gripping power of a belt, or, in other words, the co-efficient of friction, for any material used for belt-making, in its true working position, on a curved surface, simple experiments can be made:—

(1) Select a pulley, say, 12 inches in dia., properly turned and finished, and fixed; throw the length of belt over the pulley, allowing the ends to equally hang. To each end suspend a weight;

then to one end add additional small weights until the belt just begins to show signs of slipping. Divide the weight of the additional weights by the total weight upon the belt at the time it began to slip, and the quotient will be the value of the coefficient of friction for the material under test. Say we hang a 56 lb. weight to each end of the belt, and then additional weights on one end until it began to slip, the additional weight being 60 lbs., then the co-efficient of friction for the belt material under test would be $60 \div 56 + 56 = 172$. $60 \div 172 = 0.3488 =$ co-efficient of friction.

(2) Now select a second pulley, say, 10 inches in dia., place the belt as before, hang on to each end of the belt the 56 lb. weights, and then add the additional 60 lb. weight upon the one side, when it will be seen that the belt will commence to slip, as it did in the previous test. Although the surface embraced is ten times larger than when on the 12 inch pulley, yet the gripping power of the belt is not improved.

(3) A third experiment will be to take a belt made of the same material, but ten times wider, and place it over a suitable pulley with a sufficient width of face; and any diameter, and hang on the two weights as before, when it will be seen that the same additional 60 lb. weight added to one side will cause the belt to slip, in spite of the fact that the belt is ten times wider than the previous one. This will prove that the grip of a belt is precisely the same for the same total tension, whether it be a narrow belt or a wide one, or whether the pulley be large or small in diameter. In these experiments it is essential that both belt material and pulleys should be new; if not, care should be taken to remove any sticky solution from the pulley face and belting, otherwise, in comparing a narrow belt against a heavy one, the operator will arrive at an erroneous conclusion, as a belt properly cared for by applying considerable dressing (not a sticky solution) will have a much better co-efficient of friction than a belt which has been neglected and allowed to run dry. Also, in order to be correct, the weight of the belt material under test should be added to the total weight in each case, when dividing into the added weight for the co-efficient of friction.

(4) As a fourth experiment, take a case in which there is a pulley fixed to a shaft, free to rotate, with a length of belting hanging over the pulley, and to each end of the belt suspend a spring balance, which is in turn fastened to the floor by adjustable screws for varying the tension on the pulley face. Screw up the tension screws until each balance shows a reading of say, 50 lb., or a total of 100 lb. on the pulley face, which

is known as the initial tension; then set the shaft in motion, and let it rotate very slowly. Whilst the shaft is running, take the readings of each balance. This is a very important experiment, for it forms the key to the whole system of transmission of power by belts. The different tensions or readings of the two balances when the shaft is in motion depend upon the co-efficient of friction for the material under test. It will be seen that the sum of strains on the two sides of the belt is always equal to the initial tension. This difference in tension is intended to represent the driving force or working tension of a belt in motion, and, if multiplied by the velocity of belt in feet per minute will give the ratio of doing work in foot-pounds per minute.

In introducing these experiments it will be seen that a wide belt does not grip the pulley face any better than a narrow one with the same tension, which will be found correct; but it must not be imagined that I am prejudiced in any way against the employment of wide belts, for that would be absurd. It must appeal to any sane person that if the working tension is to be a heavy one, obviously the belt must be wide enough to carry this heavy tension.

The Berry Method.

After a new machine (electrical or mechanical) has been fixed, the greatest difficulty is to determine the proper width in order to transmit just sufficient energy to obtain the maximum rated output from it with minimum initial tension on both shafting and bearings consistent with highest efficiency. The only guide that the non-technical man has in deciding this, is the width across the face of the pulley usually supplied with the machine, then, if the pulley supplied is rather wider than necessary, the employer will be put to the extra expense of buying an unnecessarily wide band, owing to the man's inadequate knowledge of belt tensions or of belt capacity generally. On the other hand, should the pulley be too narrow or too small in diameter for the full or rated amount of work, the man whose duty it is to attend to the banding will be continually called upon to either use some band solution or tighten up the band every time machine is being worked up to its rated output.

To be continually tightening up the belt means courting mishap and further trouble, because there is a limit to the tension which belting will stand, and having reached that limit, it breaks and causes a complete stoppage, which may be rather serious. Another point to be considered with running belts which have been tightened to an excessive pitch, is the life of bearings, shafting, and loose pulleys. It stands to reason that where

excessive tensions are employed the life of all wearing parts must be considerably shortened.

Rule For Belt Calculations.

After years of experience with belt drives and engineering generally, I find that a good all-round and easily-remembered rule for belt calculations is that 1 ft. per minute of belt speed per inch width of belt is safely equal to transmitting one watt of electrical energy, so that, if we multiply the band speed in feet per minute by the width in inches, the result will be total energy in watts; or, dividing by 1,000, kilowatts that the band can safely be relied on to transmit, without undue tension being brought on any part of the band, or excessive friction on any part of the machinery. These data only apply to single leather belting or woven belt of equal thickness. If a light double leather band be employed, then 25 per cent. more energy may be calculated upon, or for heavy double leather as much as 60 per cent. may be added.

The great advantage in this method or rule is that it fixes a constant for working tensions, so that the working tension becomes directly proportioned to the width in inches, this constant being 44.24 lb. pull per inch width of belt.

If it is required to know the difference in pounds pull on the tight and slack side of any belt, divide the total output of machine measured in watts by velocity of belt in feet per minute and multiply results by 44.24; the product will be the extra pull in pounds of the tight side over the slack. It also conveys some idea to the average man, when he is deciding upon a belt, as to what amount of stress is likely to be brought upon it when being worked up to the maximum load, thus obviating trouble from belts being either worked excessively tight or ridiculously slack.

Rope Drives.

Of all the systems by which motion may be transmitted from one shaft to another, especially where general lineability and parallelism is not possible, the method of transmission by means of rope drives figures well up the list. Extreme lightness, easy yet noiseless running, together with practical immunity from serious breakdowns, make it preferable to any other system of gearing or heavy flat belt drives.

In the application of rope driving, the average speed of ropes is about 4,500 ft. per minute for main drives. Exceptional cases have been met with of ropes running at 7,000 ft. per minute, and in one instance I remember a main drive of ropes running at 8,500 ft. per minute, which is excessively high, and not to be recommended. The average speed for intermediate driving varies between 1,500 and 3,000 ft. per minute.

Notes on the Practice of Shading Mechanical Drawings*

By Theodore W. Johnson

Shading of mechanical drawings when reasonably and intelligently practised, enables the mechanic to apprehend the detail quickly and more correctly. The tendency to overdo this feature is pointed out by the writer, and a plea for a definite standard of treatment suggested.

THE existing rules for shading mechanical drawings when carried to their logical conclusion result in too many shade lines, which cause delay both in reading and executing a drawing, besides being unsatisfactory to the eye. New rules and exceptions are required to bring theory into accord with simplified practice, and to obviate the bewilderment which seems to result from the present complex system. So unsatisfactory is the situation that many engineers discard shading altogether as a waste of time.

Shading a Time Saver.

Properly used, shading is in many cases a great time saver, and, in spite of the breakdown of rules and divergence of practice, has a very real value. No better proof can be given than two figures taken from a standard work on mechanism. Fig. 1 is an illustration of an internal friction catch. Four catches (B) are forced by springs against an annular ring (A), and without descriptive text, we can sufficiently comprehend the geometrical shapes from the one view. The shading gives proof

*From a paper read recently before the American Society of Mechanical Engineers.

that the action is internal, besides indicating the shape of the springs. Had a section been drawn, time would have been needed for consulting it and for carrying the information (given by the shading), back to the principal view.

Fig. 2 shows an internal ratchet mechanism. By a draftsman's error, the internal ratchet wheel has been shaded as if it were an external one. Here, faulty shading clearly makes the drawing harder to understand than if it had not been shaded at all. It is a simpler mechanism than Fig. 1, yet students find it more difficult to understand on account of the fault stated.

Basic Ideas.

Two basic ideas have influenced shading:

- I.—A shade line represents a shadow, and as such should lie in any deep indentation of an object, or on any side far removed from the source of light.
- II.—A shade line marks an edge which casts a shadow. It is placed, therefore, on any edge which separates an illuminated surface from a dark surface.

The first idea is the older. The second an endeavor to be more precise. To apply it, the direction of light must be specified. With curious unanimity, authorities settled upon the body diagonal of a cube placed on the drawing-board square with the paper, as shown in Fig. 3. This makes the projected direction of light a 45 deg. line on the paper, and the true direction a line raised above it at an angle of 35 deg. 16 min.

In applying the second rule, more precise results are obtained than without it, but it becomes necessary to explain and modify it by new rules, as follows:

- III.—A projecting part does not shade a lower part, and the shadows cast have no definite length; thus, in Fig. 4, the projection (a), does not, in the front elevation, prevent light from reaching the surfaces (b), (c) and (d). The edge of the bore hole and the right edge of the object are, therefore, shaded.
- IV.—Forty-five degree surfaces, such as (e) on the plan, Fig. 4, or (f) or (c) on the front elevation, have tangent or skimming light and are considered as fully lighted.

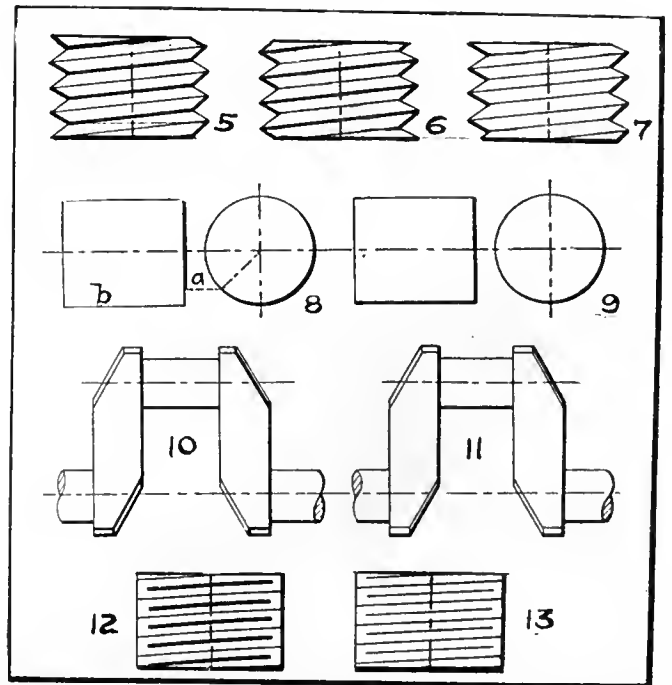
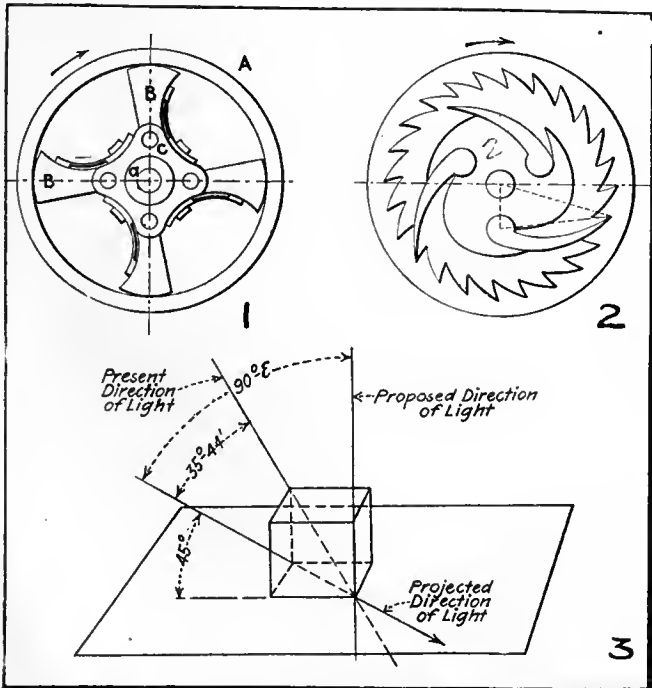

FIG. 1—SHOWING HOW SHADING AIDS IN READING A DRAWING. FIG. 2—EXAMPLE OF FAULTY SHADING. FIG. 3—DIRECTION OF LIGHT AS NOW USED AND PROPOSED. FIGS. 5, 6, 7—THREE WAYS OF SHADING A SCREW THREAD. FIGS. 8, 9—CYLINDER SHADING. FIGS. 10, 11—TWO METHODS FOR SHADING CRANK SHAFTS. FIGS. 12, 13—CONVENTIONAL METHODS OF SHOWING A SCREW THREAD.

Rules II, III and IV, mark a definite system which satisfies requirements, when no curved surfaces are encountered, except that they give too many shade lines. A general simplification, more pleasing to the eye and saving time, results from a rule as follows:

V.—Never make the line of intersection of two planes, of which both can be seen, a shade line.

The results of the rules I, II, and V, are well shown contrasted by Figs. 5, 6 and 7, representing three ways of shading a screw thread. Fig. 5 is commonest in practice. Fig. 6 is advocated by text books, but has few followers. Fig. 7 is coming into general use because it is quicker and to my mind makes a better appearance. If the threads are shaded, too great prominence is given to them.

Curved surfaces intersecting each other or intersecting plane surfaces, should be treated by substituting for them the planes which are tangent to them at the line of intersection. In Fig. 4, the edge of the hollow half cylinder (g) is shaded on the front elevation for this reason. Difficulties still arise, however, even in so simple a case as a cylinder, which should be shaded as in Fig. 8, yet no one terminates the shade line on the end of the cylinder side view at (a). Also, the need of a shade line on the bottom edge (b) is so insistent that most draftsmen shade as in Fig. 9. Rule V, has simplified shading and is a long step in the right direction. Ten or fifteen years ago, drawings from the Bureau of Steam Engineering of the Navy Department showed the crank arm shaded as in Fig. 10; now they shade as in Fig. 11. Even with this rule, however, many controversial points are still unsettled.

Conventional Method of Shading.

So hard is it to keep five rules in mind that many authors give up the ease and speak of shading by the "conventional method." All this confusion can be swept away at one stroke. A single rule, covering or merging the five rules above, and also settling points about curved surfaces in line with the best practice, can be formulated as follows:

Shade lines mark edges which separate fully illuminated surfaces from surfaces which are quite dark. The light upon the object comes from a point almost perpendicular to the paper, but inclined an infinitely small amount, so that the projected direction of light is a 45 deg. line as at present.

Referring to Fig. 3, the result is to raise the direction of light above the projected direction, from an angle 35 deg. 16 min., at which it now stands,

to nearly 90 deg. Rules I, and II, are now merged and become the same thing; the shadow and the edge which casts the shadow remain together. Rule III, is unnecessary, the projected length of a shadow on the drawing being necessarily infinitely short. Rule IV, is covered by the new rule, and rule V, is automatically observed, because no surface which is seen as the surface (not "on edge") can be a dark surface. The "right and lower edges" of the "conventional method" can now be scientifically explained, instead of referring to examples, which at best is a case of shirking responsibility.

New Rule Effects.

The practice of shading under this new rule will be that to which we are tending in all particulars: Fig. 4 for

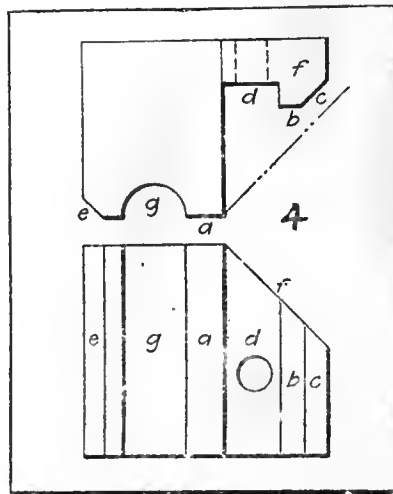

FIG. 4. DIAGRAM TO ILLUSTRATE SHADING OF INTERSECTING SURFACES.

planes and hollow cylinders; Fig. 9 for a solid cylinder; Fig. 7 for screw threads, and Fig. 11 for cylinders, cones, etc. Fig. 1 is correctly shaded, also Fig. 2, with the exception of the internal ratchet wheel.

It may be well to mention that the conventional abbreviation of the screw thread will now be as in Fig. 13 instead of Fig. 12. Fig. 12 is often used by draftsmen who otherwise do not shade at all, producing a result which is offensive to the eye. Fig. 13 is much more pleasing, and there is a distinct saving in time, as it is not necessary to wait for one set of lines to dry before putting in the other, and the double handling of instruments is also avoided.

If this rule is adopted, there will be no need for authors to write of shading. "The scientific method is universally taught and never practiced after the first blush of apprenticeship." Theory and practice will be in accord, and both will be simple.

WASHING OUT AND REFILLING LOCOMOTIVE BOILERS.

IT is found in practice, states the Railway News, that a plant for washing out and refilling locomotive boilers will justify itself in that it overcomes some of the difficulties experienced when cold water is used, and time is an element. Such installations generally include tanks, strainers, a circulating pump and heaters. One design, which has recently been introduced, includes a storage tank for the blown-out products, a filter or separator, and a pump, all mounted on a railway truck or other wheeled vehicle. If the truck is self-propelled, the pump may be driven from the propelling motor.

When a boiler is to be emptied, a flexible pipe is connected to the blow-out, and a cock in a pipe connection leading to the storage tank is opened. The blown-out products pass through a filter into the storage tank. When the boiler is empty, the cock is closed and the suction and delivery valves of the pump are opened. Hot water is then drawn from the tank and forced by the pump through a flexible pipe into the boiler for washing out and refilling. Water for washing out the boiler may be drawn from the tender through a pipe, and may be warmed by steam from the boiler admitted through a flexible pipe, and by steam passing off from the storage tank, also through a flexible pipe.



TRANSCONA TROUBLE SETTLED.

SIR WILLIAM WHYTE has made his report on the arrangement between the Government and the Grand Trunk as to the cost of operation of the portion of the transcontinental railway between Winnipeg and Lake Superior Junction, and as to the rental of the shops at Transcona and the repair shops at divisional points.

Sir William fixes two per cent. on the cost of construction as a fair rental until completion of the eastern division, the Grand Trunk to bear the cost of operation and the maintenance.

The Transcona shops and repair shops are to be included as part of the eastern division, their capacity and equipment being too great for the section from Winnipeg to Superior Junction. The rental, with the shops included, is to be two per cent. on the cost of construction, plus 10 per cent. on all work done in the shops on rolling stock for the eastern division, and plus 12½ per cent. on all work done other than for the eastern division, the Grand Trunk to maintain and run the shops at its own expense.

CHAIN REDUCTION GEARS.

A COMPARATIVELY recent application of chain drives is their use in connection with reducing gears and also in change speed boxes, examples of

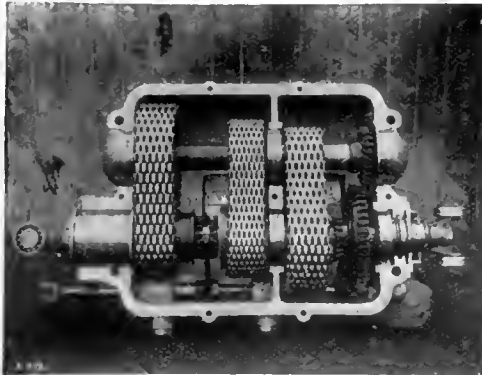

FIG. 3.—CHAIN REDUCTION GEARS.

which are herewith illustrated. Both applications are patented by the Coventry Chain Co., Coventry, England, whose representatives in Canada are Messrs. John Millen & Son, Montreal. Fig. 1 shows a chain driven speed reduction box, with the top half of the case removed. These gears are regularly made in ratios up to 6 to 1 with single reduction, from 6 to 1 up to 20 to 1 with double reduction, from 21 to 1 up to 80 to 1 with triple reduction, and from 80 to 1 upwards with quadruple reduction. The pinions are of casehardened mild steel and the large gear wheels of cast iron, all being mounted on stiff shafts running on ball bearings. The whole

gear is enclosed in a cast iron oil tight case, leakage at the bearing covers being prevented by suitable flexible washers.

This form of reduction gear has many advantages over those in which the gears mesh direct. It operates with much less noise, gives greater flexibility and perfect lubrication. It is especially applicable to heavy intermittent loads, such, for instance, as driving conveyor belts in grain elevators, etc. In such cases, the chains take up the sudden shock that would otherwise be transmitted direct to the gear teeth when suddenly starting up under a heavy load. Where the initial shocks are liable to be excessive, these reduction gears are often provided with special shock absorbing wheels.

Fig. 2. shows a Coventry chain-driven gear box applied to the reduction of the speed of an electric motor operating a cable haulage system. This illustration

is considerably longer than that of similar gears using spur and worm gearing, and that the replacement of the chains is all that is generally necessary to make the gear equal to new, as the wheels and bearings will usually wear out several sets of chains.

Fig. 3. shows a chain-driven change speed gear box for automobiles, motor trucks or motor omnibuses. It was primarily designed to secure silence and resilience, but after considerable use is said to have proved more efficient and economical than those of the usual type.



ELECTRIC DRIVING IN TEXTILE MILLS.

AN interesting article appeared recently in the "Yorkshire Observer" on electric driving in textile mills. We

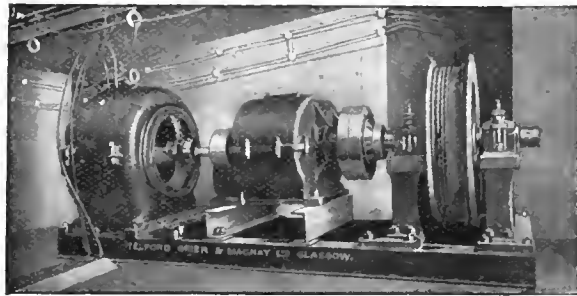

FIG. 2.—CHAIN REDUCTION GEARS.

serves admirably to show the compactness of the arrangement. It is claimed that the useful life of the gear is con-

extract some passages relating to the advantages of the direct electric drive for textile work:—

Investigations have been bearing upon the use of small motors driving directly on the machines themselves without intervening transmission devices, and after many vicissitudes, and in the face of a complete apathy on the part of conservative mill operators and not a little active opposition from machinery manufacturers, a great amount of data and information has been secured, showing that the direct drive is eminently desirable. Textile machinery is run at high rotating speeds, and an absolutely steady and uniform rate of rotation is demanded for the best production.

The cotton ring-spinners were the first to develop the individual drive, as the speed of driving the cylinder was conducive to direct connection to alternating current motors. Several large cotton ring-spinning mills have been equipped upon this system, and the results obtained are all that could be desired, because with the turbine as the prime mover beyond the motors, the speed variation has been found to be not greater than 1 per cent. from the normal. The motor is controlled by a special enclosed oil switch mounted at the end of the spinning frame, and can

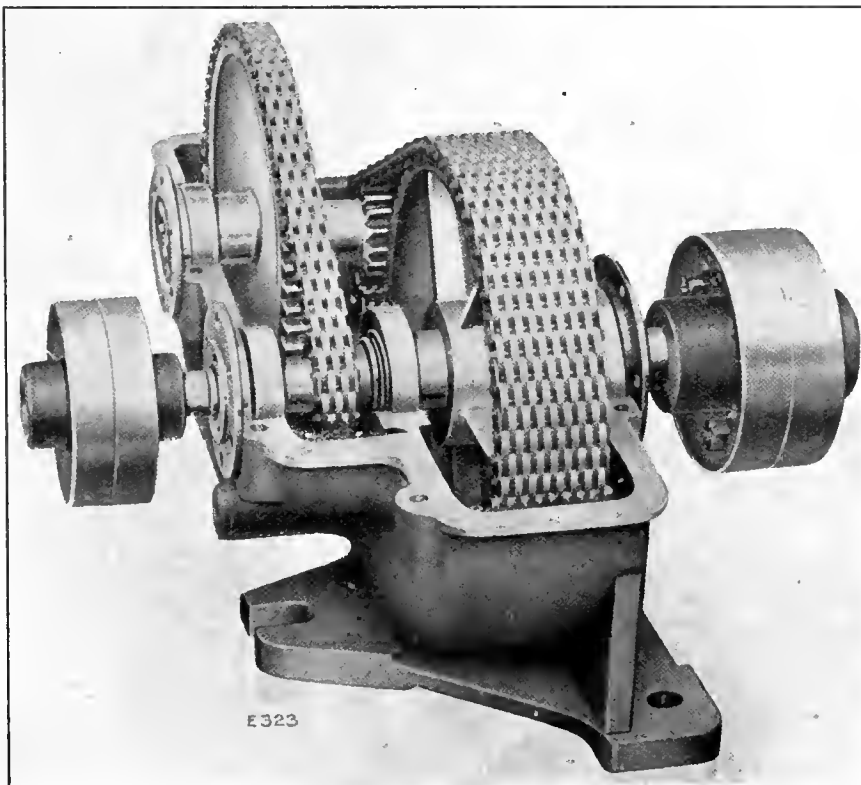

FIG. 1. CHAIN REDUCTION GEARS.

be operated either from any point along the frame, or automatically, as desired.

Seeing that successes have been met with in the operation of the individual drive in cotton mills, it is somewhat surprising that more attention has not been given to the driving of the spinning frames by this method in the worsted industry, even though high rotative cylinder speeds are not met with in the latter.

Individual Drive Developments.

Perhaps the most surprising of all the developments is that of the individual drive of silk, worsted, woolen and cotton looms. Here the parts are reciprocating and the rotative speeds are lower, but the benefits from a perfectly uniform speed are most marked, for, on account of the possibility of making closer speed adjustments, there is much less breakage of loom parts. Although the principal effort in developing these drives was originally expended in the cotton industry, they have become no less popular in the woollen, worsted, and silk mills.

Owing to the importance of good speed regulation, the loom has presented in all branches of the industry an exceptional opportunity to display the good points of the small motor drive. The advantage of this drive was soon realized, especially in the silk industry, because the product of that industry is so valuable that improvements in weaving are of importance, and particularly because oil drippings from overhead shafting cannot so easily be removed as from cotton or worsted.

In any event, an immense number of cotton and silk mills now consider this the standard drive, and will install no other. The motors have a very high efficiency and starting torque, and are either geared to a large friction clutch which disengages from the loom upon stopping, thus effectually removing all shock from both motor and loom, or a belt is used, the motor being arranged so that all slack may be easily taken up when desired. A special switch controlling the motor circuit is simultaneously and automatically opened, so that the power consumption stops when the loom ceases operation.



MR. L. S. STARRETT.

THE twenty-fifth of April marks the seventy-seventh birthday of one of the most widely-known men in the whole realm of machinery—L. S. Starrett, for it would be hard to find a machinist who never used some tool bearing his name. Mr. Starrett has built up the largest business in the world devoted exclusively to the manufacture

of machinists' tools. At any early date he showed his ingenuity by inventing a washing machine, a butter worker, and a meat chopper; and, to manufacture these, he started up his own machine shop. He thus became interested in methods of manufacture, and devoted himself to the invention of tools which would increase the efficiency of the operator.

The first tool invented by him is now almost universally used—the combination square. Soon afterwards he added to the combination square, the centre head and protractor which are now known as the combination set. As new tools were added, the business grew, and he was

them and invented a method of his own which eventually proved superior. His method of etching is now used for graduating the Starrett instruments. Mr. Starrett, although perhaps not so active as formerly in the management of his business, is a prominent figure in Athol, and continues to devote a great deal of his time to municipal affairs in his home city, the young men of which receive his especial attention.

Canadian Machinery joins with the machine tool and allied interests in congratulations to Mr. Starrett upon having attained to his seventy-seventh birthday, and gives expression to the hope that he may have many happy returns.



L. S. STARRETT.

compelled to make further and further additions to his plant at Athol. The factories now cover several acres and give employment to nearly a thousand hands.

Mr Starrett has always prided himself on the originality of his productions. A great many of the tools which he invented were not made by other manufacturers until Starrett patents had expired. As a side light on his vigor in attacking any problem, there may be cited the troubles he encountered in manufacturing his first tool. At that time there was but one concern in the country with machinery delicate enough to graduate the scale of the square. This company refused to handle the work, claiming that they had already too much of their own. They were so independent in the matter that Mr. Starrett promptly ceased negotiations with

HEAVY STARTING TORQUE.

WHEN specially heavy starting torque is required, as for crane motors and motors for operating sluice valves or small compressors, squirrel-cage machines are built with rotors of high resistance, giving a slip of 8 to 10 per cent. at normal load. The rotors are specially constructed to withstand the heat developed in them without deterioration, and are generally started by switching on full voltage. Crane motors are controlled by varying the terminal pressure by an auto-transformer with tapings. A motor with a good overload capacity and a normal slip of 5 per cent. will give a good starting torque without taking an excessive current. In no case is there much advantage in increasing the slip above 10 per cent. The smaller the slip the better the efficiency.

MACHINE SHOP METHODS ^A_D DEVICES

Unique Ways of Doing Things in the Machine Shop. Readers' Opinions Concerning Shop Practice. Data for Machinists. Contributions paid for.

BENCH LATHE OPERATION.

By A. L. Mourad.

THE writer was required to make three cylindrical master, manufacturing and inspector gauges, as shown by detail (A) in the illustration. These had to be absolutely perfect in measurements and exact duplicates of one another to .0001 inch. A few years ago a task of this kind would have been considered expensive and almost impracticable. With our modern bench lathe tools and improved methods, a skilled tool maker can now produce quite accurate work with a little care and perseverance, and in a very reasonable time.

The old timer is still in the habit of laying out work with lines according to his measuring tools on hand, but this method is fast disappearing, because very accurate operation cannot be obtained thereby. Every cut, whether nulling, boring, shaping, etc., must be gauged and measured for each operation, so that when finished there is absolute certainty about it. In order to make this article clear, not only for the experienced toolmaker, but also for the beginner, the writer will proceed in detail from beginning to end to prove the utility claimed.

Preliminary Steps.

Take a bar of good tool steel of proper length for three pieces, making allowance for cutting off and facing,

also centring. After turning on its diameter to proper size, allowing .010-inch for grinding, cut off and face each to length on an engine lathe, here again, allowing .010 inch on ends for grinding. For exact duplication of the three gauges, make an unhardened tool steel master plate (B), about the same length as the gauges, and after finishing in a shaper with a 30 deg. V groove on the side, drill and tap holes in the middle for the 5-16-inch strap screws (C).

We are now ready for the bench lathe operation, and to start with, the face plate (D) should be tested with an indicator for running absolutely true, after which the master-plate should be strapped to the face plate with four screws (C). The face plate should next be balanced by means of small lead weights strapped on the back, and by removing the driving belt from the cone pulley, it can easily be detected which side hangs down most. If the face plate be not balanced properly, the work will get out of alignment when the lathe spindle is running full speed. With the master-plate equally central from all four sides, a 3-16-inch hole is drilled and bored through its centre.

The headstock is then loosened and

moved forward to allow room for the index finger block (E), and a No. 180 index plate (D') is placed on the outer end of the headstock spindle. When properly adjusted in relation to the master plate, it is held securely by a screw (S).

The master plate V groove is now indicated parallel to the lathe bed, the headstock, index block and plate (D') being securely fastened. A swivel compound slide rest (F) is placed on a 2-inch extension block in the ways of the lathe bed and secured in position by a T bolt (G) through the centre of the lathe, and held by a hand nut (H). The screw (I) is loosened on each side and the compound slide tilted over thirty degrees—division lines are not shown as they lay down on the circular surface.

On top of the compound slide rest in the T groove is placed a sliding angle iron (J), which is held in position by a T screw and a spanner wrench nut (K). A milling head spindle is strapped in place of the spindle grinder by 2 hexagon nuts (L). With a 3/8-inch end mill, a light finishing cut is taken across the slides in the V groove on the master plate, by indexing in 90 and 180 grooves on the index plate. This assures that the V groove is absolutely central with the hole in the master plate. The bench lathe is now stripped off for turning.

A plug collet (M) is placed in the lathe spindle, and is held in place by turning the wood handle (N). A tapered tool steel plug (O) is driven into the

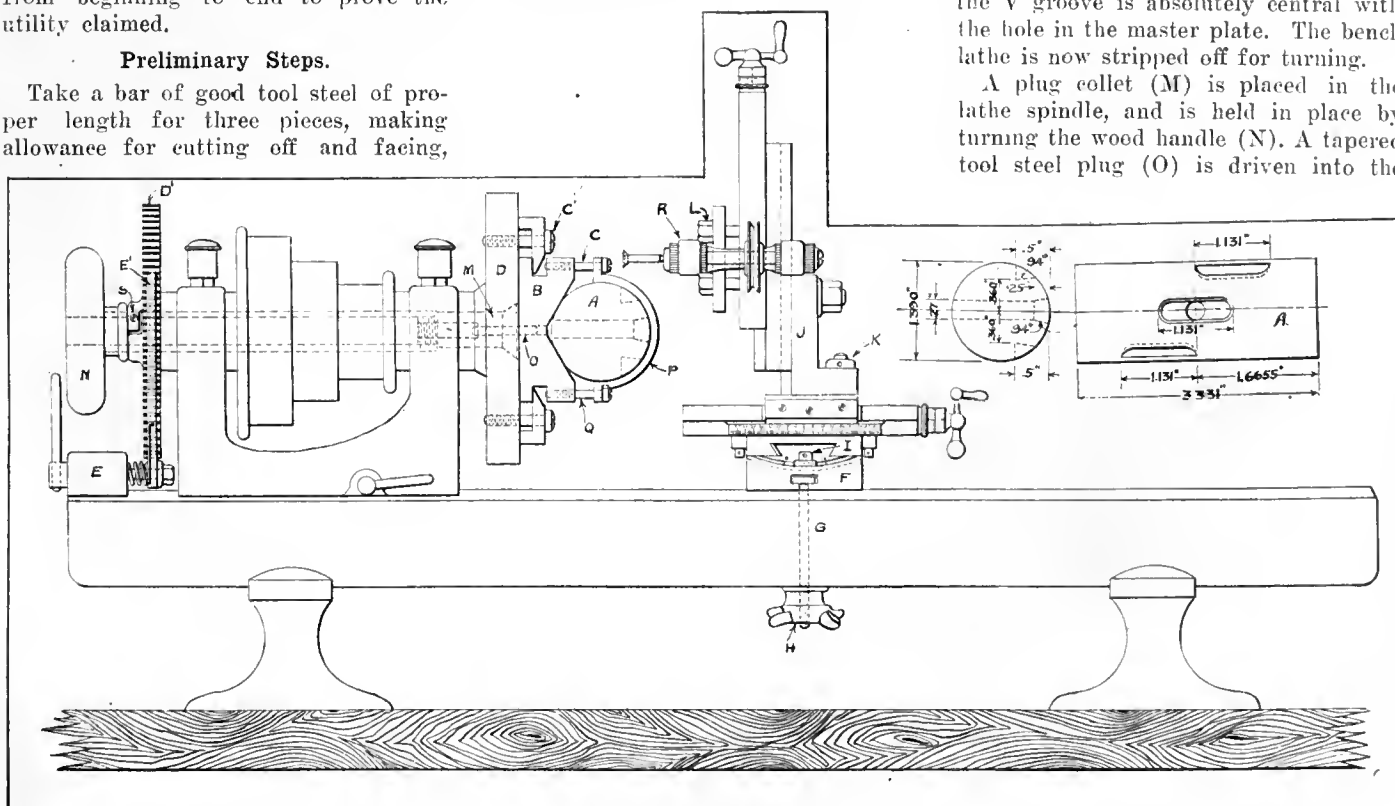

BENCH LATHE OPERATION.

tapered hole in the collet, and is turned to a 3-16-inch diameter, plus .0003-inch larger than the master plate hole, care being taken that the shoulder of the pin plug is below the surface of the face plate. The pin plug is now polished off on its diameter with a piece of emery cloth until a wringing fit with a little thick oil in the hole of the master plate. The face plate is next screwed on the lathe spindle, and the surface indicated to run true.

The master plate is now fastened to the face plate with the strap screws (C'), and the gauge blank (A) placed in position and held securely with a strap (P) and screws (Q). Care should be taken to equalize the tension of the screws (Q) so as not to twist the work (A) during operation. The gauge is indicated on each end so as to be central with the hole in the middle to be bored, this being done by loosening the screws (Q) just enough to hold the work in place. Do not drive or hammer to any extent on the ends when indicating, on account of the liability to bend the plug (O).

Set the index plate (D¹) in No. 180 groove, and square the master plate from the bed. Indicate across the end surface of the work, reverse the spindle and index finger (E¹) in groove No. 90, and repeat the operation until the indicator shows the same on each end. To be certain, indicate the diameter of work, with index finger (E¹) in No. 45 and No. 135 groove. Turn back the index finger (E¹) by hanging a weight on the end while the spindle is turning for boring. The hole is then drilled and bored to dimensions which allow .007-inch for diamond grinding.

A milling fixture is next placed on the lathe bed with a 94 degree tapered end mill on its spindle, the index finger is turned back in groove No. 45, and an indication is made on top of the master plate to be sure it is parallel with the milling fixture. Set the milling cutter central with the hole, and take the reading on the screw dial (assuming the screw lead is perfect) on both the horizontal and vertical handle. With a light cut, go across on one side to measurement, allowing .005 for grinding. With the same setting, mill the other side by reversing the lathe spindle around to index finger in groove No. 135. Stops are provided on the left hand side of cross slide in milling fixture. Repeat this operation until the required measurements are attained, allowing .005-inch on each side for lapping. On top of the diametrical surface a groove is cut with the stops setting as in the milling fixture, the cutter being a diamond wheel of same diameter, but with the angle running the other way. The verti-

cal depth of cut is obtained in the following manner:—

Vertical and Horizontal Depth of Cut.

Take a thin parallel steel strip and lay along the outer diameter in front of hole just bored. While the cutter is running, feed it up so that it just barely touches the parallel steel strip. Note the reading on the vertical handle plus the thickness of parallel strip and minus .005-inch for grinding. Raise the cutter up and feed in the required vertical depth.

The horizontal depth is obtained with the aid of a listener. Note the reading when it commences buzzing and mill down the required depth. As we allowed .010-inch for grinding the diametrical surface, this leaves us .005-inch for grinding the bottom of the groove. By reversing the spindle with index finger in No. 135 groove, and with the same setting of stops and graduation readings, the other side is milled in precisely the same manner. The gauge is next machined to its required measurements. Pieces 2 and 3 can be duplicated in like manner if care and perseverance be applied. After the gauges are pack-hardened, as described in a previous article (page 261, Canadian Machinery, March 13, 1913), they are drawn to a straw color as follows:—

Drawing Process.

Polish them well all over with emery cloth, then take a piece of flat steel, about 1/2-inch thick and large enough to cover all the hardened pieces while standing up, and leave it on a stand over a Bunsen burner until heated to a blue color. The heat draws the temper evenly all over to a light straw color by continually turning the pieces over on the ends. They are then allowed to cool off naturally on a piece of wood.

After this, the pieces are ground all over to dimensions in precisely the same manner as when machining them, with a few exceptions. A false brass centre, long enough to grip a lathe dog, is soldered on each end, by taking a soldering chuck and boring a recess to fit the end diameter of the hardened gauges. With the aid of the tailstock and back rest the gauge is soldered on to the chuck. The female centre is now drilled and reamed central with gauge, the operations being repeated on the other end. The diameter is ground parallel, allowing .0003 for lapping.

Grinding the Ends.

To grind the ends, take a soldering chuck and bore a recess to fit the diameter just ground. Use a thin sheet of brass between the jaws and gauge in the back rest. With the tail stock against the end, the gauge is soldered on to the chuck. Next face off by grinding only

enough to thoroughly clean the surface. To grind the other end, repeat the previous operation, allowing .0004-in. for surface lapping.

To measure the distance over all, cut a slot in the soldering chuck, and with a micrometer of narrow beam, the distance can be measured inside the back rest. To grind the hole in the middle, insert the plug (O) in the collet (M), and indicate the end of plug to run true. Place index plate (D¹) and block (E) in proper position, also the face plate (D) and indicate it also to run perfectly true. Strap the master plate (B) on the plug (O) and have the gauge strapped on the master plate.

Indicating the Hole.

To indicate the hole, make a plug that fits the tailstock spindle and the other end of the gauge hole. Draw up the tailstock so that the plug enters in the gauge hole about 1/8-inch. Tighten the straps (P) sufficiently to hold while turning spindle around. Balance the face plate thoroughly, and indicate both ends of the gauge as previously explained, and, at the same time, the whole distance of centre hole. If one end of hole runs out a little, by strapping down more on one side than on the other, correction becomes easy.

The tool post grinder (R) is placed between the straps in the sliding angle iron (J) and the hole ground parallel to dimensions, allowing .0003-inch for lapping.

For inside setting when finishing holes by grinding, particularly when the work is hardened and has to be lapped, it is especially desirable to get the hole as nearly parallel as possible. This may be done by feeding the diamond wheel through the hole and making it cut first on one side and then on the other. By noting the buzzing of the wheel, the slide may be set so that the hole can be ground parallel to an extreme degree of accuracy.

The Listener Feature.

If the hole is very deep or small in diameter, so that the sparks cannot be seen, a "listener" is used, which consists of a piece of small drill rod with a handle on one end. The end of the rod is applied to some part of the grinder, and the handle is held close to the left ear. By the sound emitted, when the wheel is in contact with the work, it is easy to tell if the cut is the same throughout the length of the hole on both sides.

If this listener is not sensitive enough, a tin can, having one end open, may be applied to some part of the grinder or to the top of the sliding angle iron. The contact of the diamond wheel with the work can be easily heard by listening at the open end of the can, even

though the wheel is not taking a cut deep enough to make a visible mark in the hole.

These methods are not only better, but far quicker than the old way of calipering for parallelism. To grind the groove, the same method is applied exactly as when machining, except that diamond wheels are used instead of an end mill, allowing .0002-inch for draw lapping.



A SIMPLE INDEXING AND FILING SYSTEM.

By D. O. Barrett.

SUBSCRIBERS to present day Technical Journals are sure to find something in them desirable for future reference. If the articles are left in the original publications, they soon become too bulky, and the process of locating one of them consumes too much time. The only possible means of keeping up-to-date and following the trend of development along any one line being through the numerous periodicals received, the importance of properly filing articles so that they may always be ready for future reference is shown by the various methods employed for this purpose. The method here described is very simple, and, after once being tried, is its own recommendation. The necessity for something of this kind is felt by all, even the most humble mechanic, as he is sure to see something in his monthly paper that he knows he is likely to need later on and which he cannot remember, yet, when the time comes, the article has been mislaid, and all he has is a memory of something gone and forgotten as well.

Basis of the System.

The basis of this system is ordinary letter files of the box type, costing from twenty-five to forty cents each, and, if desired, one need not be purchased until the others are all full. Being dust proof, they need not be kept in a case for protection; they will also stand a considerable amount of rough usage. These files are divided inside alphabetically, when purchased, and are numbered as added. For important subjects, such as machine tools, foundry work, patterns, gas engines, tractors, etc., it is well to set aside a complete file, so as to keep, as nearly as possible, all articles of a kind together, although this is not at all essential to the operation of the system. It is not even necessary to keep an article bearing on a certain subject in the file covering that subject as it can be as readily found in any other. The articles are first cut from the magazine and the different

leaves comprising them either pasted or fastened together with clips. Whenever there is much matter to be taken from one magazine, it is better to remove the staples at the back, as the leaves may then be more readily taken out, besides there is more room for pasting or fastening.

Routine of the System.

The title of the article which is desired for reference is underlined with a red pencil so that it may catch the eye immediately, and in the upper left hand corner are marked the number of the file and the letter under which it is classified, and in the right hand corner is marked the number of the article under that letter. For instance, an article on machine tool design marked (15)—(C) in the left hand corner and (6) in the right hand corner would indicate that it was the sixth article under the letter (C) in file 15. In this manner every article finds its way back to its original place regardless of the person using same. It is not necessary to have the title marked on the outside of the article, should it occur on an inner page.

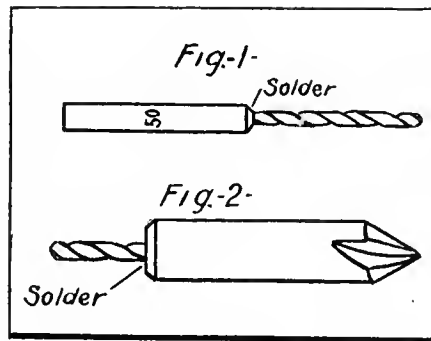

TWO KINKS FOR SMALL DRILLS.

Of course, this necessitates a card index, and there is nothing simpler or better after having given it a trial. It saves much useless handling of material, as one can skim over the cards in an index in the time it would take to get down and open a file. Then, again, several articles may be indexed under the same heading and on the same card, although in entirely different files. The cards are written in the following form, ordinary 3in. x 5in. cards being used.

- 17—A5—Machine tool design, F. R. Johnson. (Photos)—Bearing especially on lathe design.
- Canadian Machinery, Jan. 15, 1913.
- 9—N3—A new boring mill design, editorial. (Drawings).
- Mech. World, June 5, 1911.

On the card is noted whether there are drawings, illustrations, photos or other particular nature of the article.

By using a card index, one is enabled to cross-index, and this should be done freely, as an article may bear on sev-

eral subjects, and the person hunting for information may not remember to look under some closely-allied title. Then again, others may desire to use the index, and may consider that the subject should more properly be classified under some other heading. The cards are classified under headings and sub-headings, such as machine tools, machine tool design, machine tool operation, machine tool tests, etc. Articles not in the possession of the owner of the index, but which are likely to be wanted for reference, should be listed the same as the others, omitting the file numbers of the cards.

This system has been given a thorough tryout, and anyone practising it will appreciate the advantages it has over some of the more complicated systems in use.



TWO KINKS FOR SMALL DRILLS.

By J. E. Cooley.

TOOMAKERS and die makers know that the smallest size drills are inconvenient to handle, especially those between No. 45 and No. 60, the diameter of which ranges from .082 to .040. They are so small, one has to exercise constant vigilance when using them, as they may slip out of the hand when in the act of placing them in a drill chuck and fall on the floor and become lost. If these smaller sizes were fastened in 1/8-inch drill rod, 1 inch long, fig. 1, and soldered, all this trouble would be avoided, besides they would be easier to handle. Owing to the smallness of their diameters it is not possible to place the numbers on them, but as shown in the sketch, the smallest drills can be numbered.

The sketch shown in Fig. 2, is a combination countersink and drill. The drill is fastened on the end of a countersink and soldered. It is a very handy way to use up broken drills.



FINISH FOR PATTERNS.

By D. O. Barrett.

AN excellent finish for metal patterns or core boxes is made by mixing talcum powder or soapstone with the ordinary shellac and applying in the usual way. When sandpapered down to a smooth fine surface, it takes the eye of the molder and needs to be tried, but once to meet with his approval. Some molders prefer it on wooden patterns as well as metal. By mixing up very thick so as to form a paste, it is suitable for filling in blowholes and any unevenness in the iron of the pattern.

DEVELOPMENTS IN MACHINERY

A Record of New and Improved Machinery Tending Towards Higher Quality and Economical Production in the Machine Shop, Blacksmith Shop or Planing Mill.

AUTOMOBILE WIRE WHEEL SPOKE SWAGING MACHINE.

THE accompanying illustration shows an improved type of automatic swaging machine, designed and built by the Langelier Mfg. Co., Providence, R.I., for swaging auto wire wheel spokes. It takes the wire from the coil, straightens it before entering the machine, swages the spokes between butts, and mechanically cuts them off to length after swaging, all operations being entirely automatic and absolutely without waste or manual handling.

This machine has a very high output, reaching on ordinary automobile wire

ed to the correct off-set, these eyelets do not require to be disturbed for a long time, as no perceptible wear occurs.

The wire enters the special swaging machine through the rear end of the hollow spindle carrying the dies, and as it is drawn through the swaging dies, these close automatically over the wire, after allowing the portion forming the butt to pass out of them, and impart a high number of sharp, clean blows simultaneously in couples from diametrically opposite directions on the stock, redrawing it rapidly and giving it a sort of "hammer temper" for the distance between the butts. The dies again open

or decreasing the arc of travel of the segment gear and correspondingly varying the travel of the saddle on the horizontal slide above the bed, producing thereby spokes of different overall lengths and with different swaged portions between the butts.

The wire gripping chuck carried by the saddle closes on the wire for the outward or drawing stroke and releases the wire at the end of same, being entirely clear during the return of the chuck to its starting position for drawing out the next spoke. The automatic operation of the chuck is obtained through the up or down action of a wedge, actuated by the saddle as it reaches its extreme points of travel. At the end of this outward stroke the wire is gripped firmly in the cutting off attachment, while the saddle rapidly returns to take the next spoke forward, and the finished swaged spoke is cut off just before the next drawing stroke begins. The cutting off attachment consists of two hardened and ground steel bushings, whose two cutting faces are in close contact, and slide past each other rapidly at the proper time, cutting off the swaged spoke with an almost perfect shear, and without any deformation of the wire, the ends cut off being sharp and square with the wire.

Forced oil lubrication to all running parts and on the dies is maintained by an automatic oil feed pump. Other types of wire feeds besides that described are also put on to suit different maker's spokes, and the machine is built for either belt or motor drive. The net weight is about 6,500 lbs., and the floor space occupied about 3 x 6 ft.

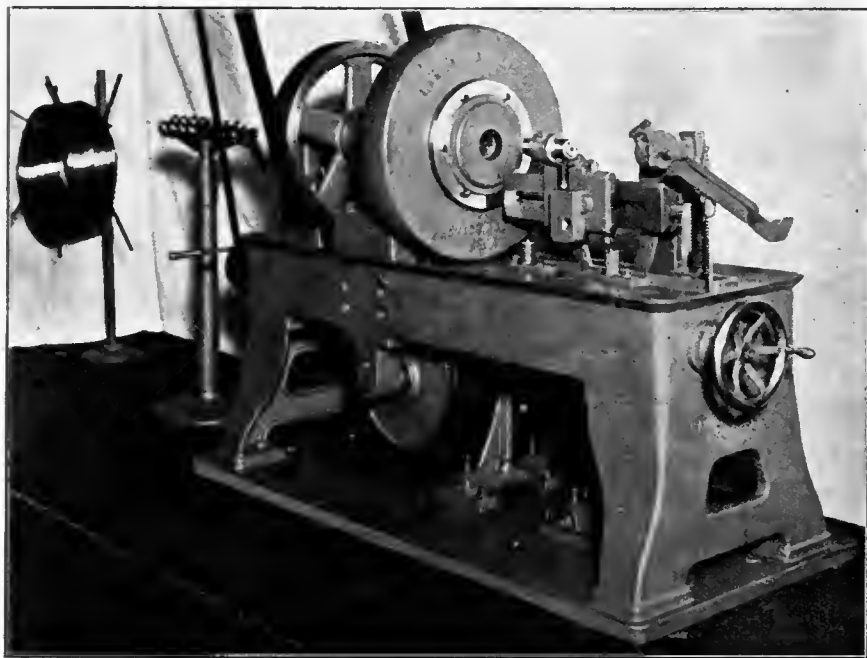

AUTOMOBILE WIRE WHEEL SPOKE SWAGING MACHINE.

wheel spokes as high as 3 spokes a minute, all straightened, swaged and cut off. All time losses between operations are eliminated, thus, while one spoke is being swaged, a finished spoke is being cut off. The coil of wire is supported on a wire reel resting on the floor at the extreme left, from which it unwinds as it is drawn through the straightener on its way to the swaging machine. This straightener is of an improved design of the rotary type wire straighteners built by this company. It has offset steel eyelets mounted with ball bearings in suitable holders, so designed that the offset eyelets do not bear in an unyielding manner against the passing wire, but revolve so that no marring of the finish of the wire occurs. Once properly adjust-

mechanically, allowing the portion of wire forming the opposite butt to pass out of the machine unswaged. The outward travel of a saddle with chuck mounted on a horizontal slide in front of the machine head draws the wire through. This saddle is provided on its rear with a rack, seen projecting at end of slide in photo, in which meshes an oscillating segment gear, already set in motion by a race cam and roller underneath the bed of the machine.

The connection between the segment and the cam roll lever is obtained by means of a special form of link having a right and left hand nut, readily reached and locked from the rear, which upon being adjusted vertically, varies the centres of the link pins, increasing

WORM SCREW PULLEY BLOCK.

THE "Ryland" Patent Worm Screw Pulley Block, with self-contained lowering and control brake is manufactured by Youngs, Ryland St. Works, Birmingham, England, and marks an entirely new departure in worm geared hoisting blocks. The worm block, with its small headroom, great lifting power, and easy working has enjoyed a large degree of popularity, and recently it has been improved by the addition of a thoroughly efficient and reliable lowering and control brake. The brake wheel is screwed on to a ratchet cup on the back end of the worm spindle, and is fitted with a brake ring attached to the brake lever. One end of the load chain is fix-

ed to the brake lever, ensuring that the load applies directly the braking pressure to the bottom side of the brake wheel.

When a load is being lifted, the ratchets slip on each other, but lock immediately hoisting ceases, the load itself holding the brake wheel fast. When a load is being lowered by hand, the ratchets and brake wheel revolve all together inside the brake ring. If it be desirable to lower quickly, by pulling the brake cord and lowering the brake ring from the brake wheel, the load can be made to run down freely. On pulling the brake cord harder, the brake ring is brought into contact with the top side of the brake wheel, and the speed of lowering can thus be controlled at will by the operator. This quality of lowering by brake is very valuable in a pulley block which is in constant use in workshops and warehouses where large quantities of goods have to be handled.

The "Ryland" worm block is made at present in four sizes, viz., $\frac{1}{2}$, 1, $1\frac{1}{2}$, and 2 tons, and each block is tested to 50 per cent. overload by dead weight, before leaving the makers works.

LABOR BUREAU REPORT.

ACCORDING to the Labor Department at Ottawa, industrial conditions were not very seriously affected by trade disputes during March, an improvement being evident as compared with the preceding month, while conditions were much the same as during the corresponding month of last year. There were in all fourteen disputes in existence, involving directly about 2,120 employees. A satisfactory feature of the disputes commencing during March was that the only ones which affected a considerable number of employees were of short duration. These included strikes of garment workers at Toronto; textile workers at Montmorency Falls, Que., and telephone employees at various points in British Columbia.

UNITED STATES SHIPBUILDING IN 1912-1913.

RETURNS received by the Bureau of Navigation indicate that the current fiscal year will show an output of American shipyards greater than for any of the past four years, and equal to the average annual output for any series of active years of construction. For the nine months ended March 31 the merchant vessels built in the United States and officially numbered, comprised 1,114 of 260,265 gross tons, compared with 1,051 of 151,341 tons for the previous corresponding nine months. As the

spring and early summer are generally the season of greatest progress, the output for the year will probably reach 400,000 tons. Steel steamers built aggregate 151,507 tons, compared with 75,507 tons for the corresponding nine months a year ago. Shipbuilding on the Great Lakes shows little change, but the total output on the Atlantic seaboard has increased from 64,522 tons to 161,061 tons. Wood sailing vessels show a decrease, and form only a small fraction—11,971 tons, of the total.

NO. 7 GREENERD ARBOR PRESS.

THE No. 7 Greenerd Arbor Press is the largest of this type machine that the manufacturers, Edwin E. Bartlett, Boston, Mass., have yet brought out. It takes in a diameter of 36 inches, and has a leverage of 250 to 1; a pres-



NO. 7 GREENERD ARBOR PRESS.

sure of 25 tons being easily obtainable. No change in principle or design has been made from the well-known No. 5 Greenerd machine, except in size and power. When the lever is in the position shown in the illustration, the rack or ram may be easily moved up or down by means of the hand wheel.

The knee is operated by the crank shown, revolving a screw through a pair of mitre gears. This screw runs in a nut in the base. The design is such that the knee can be lowered to its extreme position without the screw reaching the floor, making it possible to place the press in any position without cutting the floor for the screw. The knee

is held to the frame by two studs and nuts, these nuts being adjusted and locked so that the knee can be easily moved. The pitch of the elevating screw is such that these nuts do not require tightening to hold the knee under the heaviest pressure.

QUICK METHOD FOR CONVERTING TEMPERATURE FIGURES.

M R. CARL HERING, Philadelphia, has recently made public a simple and easily remembered approximate rule for mentally making temperature calculations, doing away with the troublesome factor 5-9, relative to the conversion of Centigrade to Fahrenheit degrees, and vice versa. It gives accurate results in converting Centigrade into Fahrenheit, but there is a slight error when applied in the opposite direction.

To convert Centigrade to Fahrenheit: Double the Centigrade temperature and deduct one-tenth of that figure (or deduct 10 per cent., then double it) and add 32. Thus, 1,000 deg. C. doubled is 2,000; less a tenth (200) leaves 1,800 deg. F.; adding 32 gives 1,832.

To convert Fahrenheit to Centigrade: Halve the Fahrenheit temperature and add one-tenth of that figure (or add 10 per cent., then halve it). Thus, 2,000 deg. F. halved is 1,000; plus one-tenth (100) gives 1,100 deg. C. Accurately it is 1093.3 + deg.; hence the approximate value is only about $\frac{1}{2}$ of 1 per cent. too high. Again, 3,000 deg. F. halved is 1,500, plus a tenth (150) gives 1,650 deg. C. Accurately it is 1648.9—; hence the approximate value is less than one-tenth of 1 per cent. too high. For the lower temperatures this rule is not applicable, the error increasing as one descends the scale. It is merely a quick approximate rule for mental calculation of the higher temperatures at which metallurgical processes are usually carried on.

The mathematical proofs of these rules are very simple, as the correct factors are 5-9 and its reciprocal, besides the 32.

U. S. ELECTRIC POWER OUTPUT.

THE combined electric output of the 7,500 central stations in the United States for the year ended December 31, 1912, was 12,000,000 h.p. While this amount is, of course, large, it is only a part of the total electric power generated, as it includes only public service companies and takes no account of the great railroad and manufacturing companies which produce and use their own power; the total power generated is, therefore, easily double the output of the central stations.

FOUNDRY PRACTICE AND EQUIPMENT

Practical Articles for Canadian Foundrymen and Pattern Makers, and
News of Foundrymen's and Allied Associations. Contributions Invited.

ADDING OXYGEN TO AIR BLAST.

CHARLES A. Edwards, manager of the Britannia Iron Works, Middlesbrough England, after various experiments, comes to the following conclusions regarding additions of oxygen to the air blown into blast furnaces:

1.—According to the amount of oxygen added to the air blast, there results a blast furnace gas which has the composition of the best producer gases and also the same adaptability.

2.—By increasing the oxygen content from the normal of 21 per cent. by volume to 22.54 per cent. by volume, thus lowering the nitrogen content, the demands on the blast and on the stoves are reduced about 8 per cent. and the coke consumption lessened about 6 cents per ton of pig iron.

3.—The volume of the gas is lessened by the lower percentage of nitrogen, the velocity up through the various layers of the charge is slower, and the reducing power is increased.

4.—The efficiency of the blast furnace is greater by about 23 per cent.—about 8 per cent. because of lessened demands on the blast, and about 15 per cent. because less coke must be gasified.

5.—These figures will naturally be altered some according to conditions in various plants, but the question of the increase of the oxygen content of the air blast should be given earnest consideration for the above reasons.



DESIGN PATTERN AND MOULD.

By Walter J. May.

IN making a casting there are several kinds of work involved, but the final adjustment lies between the pattern-maker and the moulder, these having to produce the article originating in the drawing office. If the draughtsman understands the limitations of moulding in regard to shape and proportions of the castings required, everything works smoothly; but in many cases the draughtsman has not the necessary knowledge, and he designs things which are both costly and difficult to make. Often one sees single castings ordered, where, if two or more were used, they would have more strength and cost less, and both pattern-maker and moulder would have less work in making the thing come out alright.

There is every excuse for the draughtsman not being up in all the details of making castings, because he has, as a rule, so many things to know that detail work would probably be missed in many cases through no fault of his. In all cases, however, as the foundry has to make the articles, the draughtsman and the foundry foreman should lay their heads together to devise the best and easiest means of securing the desired results, and especially is this the case where work has to be machined. It is not desirable that ugly lumps of cast metal should be sent into the machine shop to be cut and pared into shape, but rather that the machine shop should merely finish the article.

The pattern-maker usually has had more or less acquaintance with the actual working of a foundry, and he will know pretty well what will mould easily and what shape of casting will run up best and give the greatest strength. Beyond this, the pattern-maker should be able to decide which is the easiest way to arrange the pattern for the moulder, because, on this, very much of the cost depends. Some things work best from a solid pattern, while others are most quickly dealt with when split up into two or more parts according to their form, the convenience of the moulder being a strong point in securing economy in working. The pattern-maker should always work with the foreman moulder in regard to splitting and similar details, but necessarily the requirements of the drawing-office have also to be considered.

Assuming that the patterns are made to favor the moulder, then he should work as closely as he can to prevent the castings being of wrong size, yet in some cases the casting will not always be sound where the metal is not well balanced for cooling. Then, again, it is not always possible to have metal as one would wish it to be, and this scores against the moulder, although it does not affect the accuracy of the moulding. To secure economy with good workmanship is essential in all work, but particularly is this the case in originating departments, such as the foundry and smithy, it being possible to increase work very largely in other departments when the originating work is badly designed or clumsily made. Both foundry and smithy originate work, and on the way in which the work is done, the cost of the after processes largely depends. For

this reason, the pattern shop and foundry should work together, and so far as is possible, the draughtsman should always consult the working departments. —Practical Engineer, London.



WEAR OF STEEL RAILS.

THE problem of the steel rail," is discussed by Mr. A. J. Beaton, M. Inst. C.E., in a pamphlet reprinted from "The South African Railway Magazine." Mr. Beaton, who is assistant engineer-in-chief of the South African Railways, remarks that, notwithstanding the care bestowed on designing the scientific relations between the section, weight, and composition, and the knowledge and skill expended on the manufacture of rails, the requisite accurate and specific knowledge, in connection with this most perplexing problem of railroad engineering, has not yet been attained, so as to conclusively determine the most economical section of rail and its best chemical composition. This, it is remarked, can only be arrived at by carefully kept statistics and co-ordinated tests based on the variation of traffic, and on the condition and upkeep of the track. Such tests, and the method of determining the relation between resistance to wear and the other properties of the rail, should be compiled on a foundation of theory combined with practice, in order to secure the greatest value ultimate results; for, even engineers are sometimes prone to deduce conclusions from inadequate data.

The author gives a careful summary of the investigations which have already been made or are now in progress. He mentions that Mr. A. M. Tippett, engineer-in-chief of the South African Railways and Harbors, has taken an advanced step by introducing rails of different chemical compositions for use on curves of sharp radii and heavy wear, with the object of determining the relative values of the resistance against wear of the following different qualities of steel:—

Sandberg open hearth; high silicon.

Sandberg basic open hearth; high silicon.

Sandberg Bessemer acid; high carbon.

Open hearth basic; high carbon.

Talbot open hearth basic; high carbon.

Bessemer acid; B.S.S. specification.

Bessemer basic; B.S.S. specification.

These rails are to be carefully weighed each year, while the actual tonnage passing over them will be systematically recorded. Mr. Beaton is sanguine that the data thus to be obtained will prove of great value, and will form an important factor in determining the best type of rail. It will also greatly help in deciding the permissible curvature of the future, consistent with the most economic alignment of the track. Time only can tell which of these rails will prove the most satisfactory.



Ottawa, Ont.—A judgment of the Supreme Court of Canada, recently given, may have the effect of sweeping aside the British Columbia legislation forbidding outside firms from trading there unless registered in that province. The Supreme Court has decided that the John Deere Plow Co. is not precluded from carrying on business in British Columbia or from demanding payment for goods delivered there. In fact, the court practically decides that the British Columbia Legislature cannot prohibit outside firms from carrying on business in the province. The case has attracted the attention of manufacturers all over Canada. The John Deere Plow Co., operating under a Dominion charter, had applied for a license in British Columbia, but was refused because there was already an American firm of the same name registered there. The company was, therefore, completely shut out of the Western Province, although it had a charter from the Dominion Government, entitling it to carry on business throughout Canada. The company sued on a couple of notes which it held against a British Columbia merchant for goods delivered to him. The British Columbia merchant stood pat and declared that the Plow Co. could not take proceedings against him in British Columbia. This attitude of the British Columbia merchant was maintained in all the provincial courts.

Toronto, Ont.—In the case of John Wyers against the Winton and Irving Co. for damages for loss of all the fingers of his right hand, the jury awarded \$500 damages. His Lordship reversed this, holding that Wyers' accident was the result of contributory negligence. The man was in the employ of the firm. On a cold day in October, 1912, he was ordered by a clerk in the office to get some kindling wood and light a fire. Not finding any around, he picked up some

odd pieces of board and proceeded to cut them up on a circular saw. To do this he had to remove the guard, with the result that it fell, and his hand was caught on the saw. It was alleged the saw was out of repair; that there was no warning notice displayed, and that it was dangerous for anyone but a skilled mechanic to operate. Also, that as a subordinate employee of the firm he was obliged to obey the orders of the clerk. The jury so found. His Lordship said the jury's finding was wrong. While the man was entitled to sympathy, he was obliged to non-suit him. He added that costs would probably not be asked for.

— ❁ —
INDUSTRIAL ACCIDENTS.

DURING March, according to the record of the Federal Department of Labor, 480 industrial accidents occurred, of which 93 were fatal and 387 resulted in serious injury. The greatest number of fatal accidents occurred to employees in steam railway service. Of the non-fatal accidents, 115 steam railway employees were injured; in the metal trades, 102; and in the building trades 25.

— ❁ —
POWERFUL WORKSHOP MACHINERY.

CAMMELL, LAIRD & CO. are erecting at their Grimsthorpe Works, Sheffield, an armour plate bending press, made by Davy Brothers, of Sheffield, capable of a bending pressure of 12,000 tons. A single casting of 90 tons forms a portion of the base of the press. A 180-ton overhead traveling crane is also being erected in the moulding department in place of a 120-ton crane. An additional bogie-bottom furnace is being put down for large forgings, such as gun jackets, and extensions of the steel-making plant are being carried out.

— ❁ —
ADDITIONS TO G. T. R. POINT ST. CHARLES SHOPS.

SEVERAL additions have been made recently to the buildings of the G. T. R. motive power and car departments at Point St. Charles, Montreal. Along the north side of the locomotive machine shop, a brick addition, 150 by 40 ft., has been completed, and with the additional space provided, it is expected that a better grouping of the machine tools will be possible. The new section has had a cement floor laid, and in the older section, as the machines for re-arrangement are moved, a cement floor will also be laid, one section at a time, so as not to interfere with the progress

of the work. The boilers in the locomotive department boiler house are being replaced by those of more modern type.

Car Department.

The car department is also undergoing extensive changes. To the east end of the freight car shop a 7-track addition, 130 ft. wide by 170 ft. long, the full width of the old shop, has been added. This addition is of wood, like the old shop, but of more modern construction. The roof is about half as high again as in the old shop, giving greater head room. Through the whole of the freight car shop it is the intention to have adjustable scaffolding constructed along the sides of the tracks. A 200-foot section of the south wall of the old freight shop has been knocked out, and a lean-to building, 40 ft. wide, built along that length. This section is to house the locomotive department carpenter work, such as pilots, cabs, etc.

An exhaust fan system is being installed in both the freight and passenger car wood shops for the removal of the shavings, etc., to the car department boiler house. This system will consist of one 70 in. double, two 70 in. single, and one 60 in. double exhaust fans, all delivering to the boiler house.

In the passenger car shop there is being constructed an adjustable scaffolding system, for convenience in working on the sides of cars. The car department blacksmith shop, heretofore a round building, 50 ft. diameter, has been extended by an addition to the east, the full width of the former building, making the complete building 130 ft. long.

The machinery in the car department is being changed over from line to individual motor drive, necessitating conversion of the power units. A new 16 by 26 by 25 by 16 by 18 in. air compressor, with a capacity of 1,500 cubic feet, has also been installed in the power house.

— ❁ —
CONVENIENCE OF THE MACHINE TOOL OPERATOR.

WE were under the impression that a great deal of attention had been given by machine tool designers during the past few years to the convenience of the operators, says an Exchange, but according to a writer in the Manchester Guardian, much still remains to be done. Machine tools vary so widely in size and character, he says, and the work itself is also of such variable nature, that no general law can be enunciated; but it is time that designers gave more consideration to the problem of controlling adjustments and speeds from the machinist's natural working position. Men being what they are, the controlling of the machine must be convenient.

The MacLean Pub. Co., Ltd.

(ESTABLISHED 1888.)

JOHN BAYNE MACLEAN - - - - - President
H. T. HUNTER - - - - - General Manager
PUBLISHERS OF

CANADIAN MACHINERY AND MANUFACTURING NEWS

A weekly newspaper devoted to machinery and manufacturing interests, mechanical and electrical trades, the foundry, technical progress, construction and improvement.

H. V. TYRRELL - - - - - Business Manager

EDITORIAL STAFF:
PETER BAIN, M.E., J. H. WILLIAMS, C. W. BYERS

OFFICES:

CANADA
Montreal, Rooms 701-702 Eastern Townships Bank Bldg.
Toronto, 143-149 University Ave., Phone Main 7324
Winnipeg, 24 Royal Bank Bldg., Phone Garry 2313
Vancouver, H. Hodgson, 2640 Third Ave. West.

GREAT BRITAIN
London, 88 Fleet Street, E.C. Phone Central 12960
E. J. Dodd

UNITED STATES
New York, R. B. Huestis, 115 Broadway, New York, N. Y., Phone 2209 Rector
Chicago, A. H. Byrne Room 607, Marquette Bldg. 140 S. Dearborn St., Chicago

CABLE ADDRESS:

Macpubco, Toronto. Atabek, London, Eng.

SUBSCRIPTION RATE:

Canada, \$2.00; United States, \$2.50; Great Britain, Australia and other colonies, 8s. 6d. per year; other countries, \$3.00. Advertising rates on request.

Subscribers who are not receiving their paper regularly will confer a favor on us by letting us know. We should be notified at once of any change in address, giving both old and new.

Vol. IX. APRIL 24, 1913 No. 14

PRINCIPAL CONTENTS.

System as Applied to the Shop Repairs of Locomotives.....	423-426
Growth of Medicine Hat	426
Typical Methods of Attaching Chucks to Lathe Spindles.....	427-428
The Belt Drive as a Factor in Power Transmission Work.....	429-432
Notes on the Practice of Shading Mechanical Drawings.....	433-434
General	434-436
Washing out and Refilling Locomotive Boilers.....	
Transcona Trouble Settled.....	Chain Reduction Gears
Electric Driving in Textile Mills.....	Mr. L. S. Starrett
Heavy Starting Torque.....	
Machine Shop Methods and Devices	437-439
Bench Lathe Operation.....	A Simple Indexing and Filing System
Two Kluks for Small Drills.....	Finish for Patterns
Developments in Machinery	440-441
Automobile Wire Wheel Spoke Swaging Machine.....	
Worm Screw Pulley Block.....	No. 7 Greenard Arbor Press
General	441
Labor Bureau Report.....	United States Shipbuilding in 1912-1913
Quick Method for Converting Temperature Figures.....	U. S. Electric Power Output
Foundry Practice and Equipment	442-443
Adding Oxygen to Air Blast.....	Design Pattern and Mold
Wear of Steel Rails.....	
General	443
Industrial Accidents.....	Powerful Workshop Machinery
Additions to G.T.L., Point St. Charles Shops.....	Convenience of Machine Tool Operator
Recent Judicial Decisions	443
Editorial	444
Selected Market Quotations	445-446
General Market Conditions and Tendencies	446-447
General	447
Shoe Machinery Free.....	Canadian General Electric
Absorbs Allis-Chalmers-Bullock, Montreal.....	
Industrial and Construction News	448-452

MACHINE TOOLS AT THE FOUNDRYMEN'S CONVENTION.

THE information to hand that machine tool builders are calling for space reservations at the Exhibition connected with the convention of American Foundrymen and Allied Associations, which is to be held at Chicago in October of this year, is evidence of a growing desire on the part of the machine shop and foundry to get closer together on matters pertaining to casting constituents, and relative to modern labor-saving tools and appliances forming necessary equipment features of both pattern shop and foundry. As is well known, our foundries, large and small, offer a ready market for a varied product of machine tool, and while it is true that quite a number

of large and recently built plants have taken advantage of all the equipment available, it must be admitted that many more, large, medium and small, could profitably adopt a like procedure.

The idea projected is that a completely equipped machine shop be featured at the exhibition, and we cannot help thinking that in addition to increasing the attractiveness and instructiveness of the coming display, it will, at the same time, be the means of advertising the machine tool line generally, and more than warrant the expense incurred by those manufacturers who come forward to exhibit. We are of opinion that a well-ordered exhibition of any specialty is always worth while, not alone for spot results, although these in numerous instances are many and valuable, but also for the impression left on the minds of those concerned which materializes into action and orders at dates subsequent to the exhibition. Machine tool equipment is no exception in this respect, and we are confident that the results and experiences will be so gratifying and valuable on the coming occasion that future years will see this department augmented both as regards number of exhibitors and variety of product.

OVERRATED MEN.

IT will be at once evident that there exists little disposition to overrate what may be termed the rank and file of any business or enterprise, on the part of the employer at least, although there is quite a tendency apparent in a number of instances where labor is disposed to overrate itself. The disposition in the world of industry is to rate a man at his true value, and although betimes most of us consider the finding to be not altogether to our liking, it goes without saying that the error is, generally speaking, never a very grave one. It is a noticeable feature of our time, that a misjudged confidence in a man's ability and capacity meets with speedy correction, and the higher up the rank, the more noticeable the incompetency.

Little tolerance is displayed towards incompetency and inefficiency in manufacturing production and its kindred accessories, and to this attitude is largely due the high attainment and achievement recorded. Is it not possible then to have the same spirit pervade our public business undertakings; and need we go beyond the realm of municipal government to find out how far short the latter falls of reasonable performance? The root of the trouble is, we believe, to be found in the utter helplessness and incapability of the people's representatives, and while there are doubtless grades of the disease, and although some of our municipal bodies have higher percentages of a less virulent incapacity in their make-up, the fact remains that they all blunder, yes and blunder badly.

The City of Toronto, in the persons of its civic rulers, is a horrible example of uselessness and incompetency, being in many respects nothing short of a laughing stock to the civilized world. What wonder is it then, that, with the glaring lack of harmony apparent among its rulers, nothing undertaken can be brought to a successful issue. It would seem invidious to select a particular example of failure, as none other but the latter term is applicable, yet, the palpable incapacity shown to compass the cleaning of the water supply tunnel across the Bay being of so recent a date, calls for special mention. In spite of the careful and persistent propagation of the idea that the head servants of the Corporation were "big men," "clever engineers," and the "men to do things," we have been shown in practice that they are otherwise. Further, it is amply evident that the men themselves and their employers fail to appreciate the situation. If industrial enterprise was on a like footing, heaven help us all.

SELECTED MARKET QUOTATIONS

Being a record of prices current on raw and finished material entering into the manufacture of mechanical and general engineering products.

PIG IRON.		Per Ton.	
Foundry No. 1 and 2; f.o.b., Midland	\$19 00	\$19 50
Gray Forge, Pittsburgh	16 15	
Lake Superior, charcoal, Chicago	18 00	
		Mont'l.	Tor'to.
Canadian f'dry, No. 1.	\$21 00	\$20 00	
Canadian f'dry, No. 2.	20 50	19 50	
Middlesboro, No. 3.	23 50	23 50	
Summerlee, No. 2	25 00	26 50	
Carron, special	25 00	
Carron, soft	25 00	
Cleveland, No. 1	24 25	25 00	
Clarence, No. 3	23 75	24 50	
Jarrow	25 50	
Glengarnock	26 00	
Radnor, charcoal iron.	30 00	34 50	
Ferro Nickel pig iron (Soo)	25 00	

BILLETS.

	Per Gross Ton.
Bessemer billets, Pittsburgh	\$28 50
Open hearth billets, Pittsburgh.	29 00
Forging billets, Pittsburgh.	36 00
Wire rods, Pittsburgh	30 00

FINISHED IRON AND STEEL.

Per pound to large buyers:

	Cents.
Common bar iron, f.o.b., Toronto.	2.10
Steel bars, f.o.b., Toronto.	2.20
Common bar iron, f.o.b., Montreal.	2.15
Steel bars, f.o.b., Montreal.	2.25
Bessemer rails, heavy, at mill.	1.25
Iron bars, Pittsburgh	1.70
Steel bars, Pittsburgh, future	1.40
Tank plates, Pittsburgh, future.	1.45
Beams, Pittsburgh, future	1.45
Angles, Pittsburgh, future	1.45
Steel hoops, Pittsburgh	1.60

Toronto Warehouse f.o.b., Toronto.

	Cents.
Steel bars	2.30
Small shapes	2.40
Warehouse import, freight and duty to pay:	Cents
Steel bars	1.95
Structural shapes	2.05
Plates	2.05

Freight, Pittsburgh to Toronto:

18 cents carload; 21 cents less carload.

BOILER PLATES.

	Mont'l.	Tor'to.
Plates, ¼ to ½-in., 100 lbs.	\$2.35	\$2.35
Heads, per 100 lbs.	2.65	2.95
Tank plates, 3-16 in.	2.60	2.60
Tubes, per 100 ft., 1 inch	9.00	8.50
" " 1¼ in.	9.00	8.50
" " 1½ "	9.00	9.00
" " 1¾ "	9.00	9.00
" " 2 "	8.75	8.75
" " 2½ "	11.50	11.50
" " 3 "	12.00	12.00
" " 3¼ "	13.75	13.75
" " 3½ "	15.00	15.00
" " 4 "	18.00	18.00

BOLTS, NUTS AND SCREWS.

	Per cent.
Stove bolts	80 & 7½
Machine bolts, ¾ and less	65 & 5
Machine bolts, 7-16.	57½
Blank bolts	57½
Bolt ends	57½
Machine screws, iron, brass	35 p c.
Nuts, square, all sizes.	4c per lb off
Nuts, Hexagon, all sizes.	4¼ per lb off
Flat and round head.	35 per cent.
Fillister head	25 per cent.
Iron rivets	60, 10, -0 off
Wood screws, flathead, bright	85, 10 p c off
Wood screws, flathead, brass	75, 10 p c off
Wood screws, flathead bronze	70, 10 p c off

National-Acme "Milled Products."

Sq. & Hex Head Cap Screws	65 & 10%
Sq. & Hex Head Cay Screws	65 & 10%
Rd. & Fil. Head Cap Screws	45-10-10%
Flat & But. Head Cap Screws	40-10-10%
Finished Nuts up to 1 in.	75%
Finished Nuts over 1 in.	72%
Semi-Fin. Nuts, up to 1 in.	75%
Semi-Fin. Nuts over 1 in.	72%
Studs.	65%
Discounts f.o.b., Montreal.	

WROUGHT IRON PIPE.

The following are Toronto jobbers' discounts on pipe in effect from April 21, 1913:

Standard	Buttweld		Lapweld	
	Black	Gal.	Black	Gal.
¼ ¾ in.	62	47
½ in.	68	58
¾ to 1½	71½	61½	68½	58½
2 in.	71½	61½	68½	58½
2½ to 4 in.	71½	61½	70½	60½
4½ to 6 in.	71½	61½
7, 8, 10 in.	66	54

X Strong P. E.

¼, ⅜, ½ in.	56½	46½
¾ to 1½ in.	67½	57½
2 to 3 in.	68½	58½
2½ to 4 in.	65	55
4½ to 6 in.	64	56
7 to 8 in.	55	45

XX Strong P. E.

½ to 2 in.	43	33
2½ to 4 in.	43	33

PRICES OF WROUGHT IRON PIPE.

Standard.	Extra Strong.	D. Ex. Strong.
Nom. Price.	Size Price	Size Price
Diam. per ft.	Ins. per ft.	Ins. per ft.
½ in \$.05½	½ in \$.12	½ in \$.32
¾ in .06	¾ in .07½	¾ in .35
⅝ in .06	⅝ in .07½	1 .37
½ in .08½	½ in .11	1¼ .52½
¾ in .11½	¾ in .15	1½ .65
1 in .17½	1 in .22	2 .91
1¼ in .23½	1¼ in .30	2½ 1.37
1½ in .27½	1½ in .36½	3 1.86
2 in .37	2 in .50½	3½ 2.30
2½ in .58½	2½ in .77	4 2.76
3 in .76½	3 in 1.03	4½ 3.26
3½ in .92	3½ in 1.25	5 3.86
4 in 1.09	4 in 1.50	6 5.32
4½ in 1.27	4½ in 1.80	7 6.35
5 in 1.48	5 in 2.08	8 7.25
6 in 1.92	6 in 2.86
7 in 2.38	7 in 3.81
8 in 2.50	8 in 4.34
8 in 2.88	9 in 4.90
9 in 3.45	10 in 5.48
10 in 3.20
10 in 3.50
10 in 4.12

IRON PIPE FITTINGS.

Canadian malleable, 40 per cent.; cast iron, 65; standard bushings, 70; headers, 60; flanged unions, 65; malleable bushings, 65; nipples, 75; malleable, lipped unions, 65.

COKE AND COAL.

Solvay Furnace Coke	\$5.25
Solvay Foundry Coke	6.50
Connellsville Furnace Coke	5.25
Connellsville Foundry Coke	5.75
Yough, Steam Lump Coal	3.83
Penn. Steam Lump Coal	3.63
Best Slack	2.95
All net ton f.o.b. Toronto.	

OLD MATERIAL.

	Tor'to.	Mont'l.
Copper, light	\$12 05	\$11 00
Copper, crucible	15 00	13 50
Copper, unere'bled, heavy	13 05	12 50
Copper wire, unere'bled	13 05	12 50
No. 1 machine compos'n	12 00	11 00
No. 1 comps'n turnings	10 00	10 00
New brass clippings	9 15	9 10
No. 1 brass turnings	8 30	7 75
Heavy lead	3 25	3 25
Tea lead	3 00	2 75
Scrap zinc	4 00	3 75

METALS.

Prices in cents per pound:

	Mont'l.	Tor'to.
Lake copper	16.25	16.25
Electrolytic copper	16.25	16.25
Spelter	6.00	6.10
Lead	4.70	5.50
Tin	51.50	51.50
Antimony	10.00	9.75
Aluminum	23.00	21.00

SMOOTH STEEL WIRE.

No. 6-9 gauge, \$2.35 base; No. 10 gauge, 6c extra; No. 11 gauge, 12 extra;

No. 12 gauge, 20c extra; No. 13 gauge, 30c extra; No. 14 gauge, 40c extra; No. 15 gauge, 55c extra; No. 16 gauge, 70c extra. Add 60c for coppering and \$2 for tinning.

Extra net per 100 lb.—Spring wire; bright soft drawn, 15c; charecoal (extra quality), \$1.25.

SHEETS.

	Mont'l.	Tor'to.
Sheets, black, No. 28	\$2 85	\$3 00
Canada plates, ordinary, 52 sheets	2 80	3 00
Canada plates, all bright	3 70	4 15
Apollo brand, 10¾ oz. (American)	4 30	4 20
Queen's Head, 28 B.W.G.	4 50
Fleur-de-Lis, 28 B.W.G.	4 20
Gorbal's Best Best, No. 28	4 45
Viking Metal, No. 28	4 40

NAILS AND SPIKES.

Standard steel wire nails, base	\$2 40
Cut nails	\$2 60	2 65
Miscellaneous wire nails	75 per cent.	
Pressed spikes, 5/8 diam., 100 lbs.	2 85

FINE STEEL WIRE.

Discount 25 per cent. List of extras. In 100-lb. lots: No. 17, \$5; No. 18, \$5.50; No. 19, \$6; No. 20, \$6.65; No. 21, \$7; No. 22, \$7.30; No. 23, \$7.65; No. 24, \$8; No. 25, \$9; No. 26, \$9.50; No. 27, \$10; No. 28, \$11; No. 29, \$12; No. 30, \$13; No. 31, \$14; No. 32, \$15; No. 33, \$16; No. 34, \$17. Extras net. Tinned wire, Nos. 17-25, \$2; Nos. 26-31, \$4; Nos. 30-34, \$6. Coppered, 75c; oiling, 10c.

MISCELLANEOUS.

	Cents
Putty, 100 lb drums	\$2.70
Red dry lead, 560 lb. casks, per ewt.	6.00
Glue, French medal, per lb	0.10
Glue, 100 flake	0.11
Tarred slaters' paper, per roll	0.95
Motor gasoline, single bbls., gal.	24½
Benzine, per gal.	23½
Pure turpentine	64
Linseed oil, raw	58
Linseed oil, boiled	61
Plaster of Paris, per hbl.	2.10
Plumbers' Oakum, per 100 lbs.	3.25
Pure Manila rope	17

The General Market Conditions and Tendencies

This section sets forth the views and observations of men qualified to judge the outlook and with whom we are in close touch through provincial correspondents.

Montreal, Que., April 21.—Business in the machinery market continued rather quiet last week, although some firms report a few orders of fair size. Dealers are still awaiting the placing of orders for the equipment of the Transcona ear shops and for the C.P.R. Western lines. Both sets of specifications were issued some considerable time ago, and it was expected that decisions in both cases would have been reached before now.

Pig Iron, Copper, Etc.

Pig iron is unchanged from last week, though with the expected arrival of the first ocean boats, a considerable drop is probable. Copper remains firm at last week's quotations, while tin has advanced another ½ cent per pound in sympathy with the English market. Pig lead after a sharp rise in the middle of the week dropped back slightly, but is still 10 cents per 100 lbs. higher than it was a week ago.

General Trade Conditions.

Money has not eased yet, and an urgent demand still exists for commercial purposes. In spite of this, however, the real estate business is active and some

large deals have recently been put through. The building trade is particularly brisk this spring, the hardware houses being of course correspondingly busy. The grain trade in spring wheat, oats and barley has been fairly large.

* * *

Toronto, April 23. — Most machine dealers found business much better this week. Collections are reported remarkably good, although business consists of small orders. The A. R. Williams Co. supplied several garages up and down the country with equipment. Holmes & Wilson, the name under which the Dominion Nickel Copper Co., of Sudbury, Ont., are doing business temporarily, have called for machinery and furnaces, and placed orders for their electrical equipment. They will also be buying compressors and mining machinery. The Canadian Fairbanks-Morse Co. received a wire from Philadelphia this week for a power boat ready equipped to go to Kenagami, Ont., where the purchaser, D. D. Shepps, has a silver mine. He will use it to haul supplies. The A. R. Williams Co. are preparing plans for the erection of machine and boiler shops on their lake front property across the

railway tracks from their present offices on Front Street. Preparations are also being made to vacate the latter for their new warehouse next to the Queen's Hotel.

Pig Iron.

The Standard Ideal Co., of Port Hope, Ont., manufacturers of Sanitary outfits, placed an order with Drummond, McCall & Co. this week for several thousand tons of pig iron. The price is the same. The Steel Co. of Canada are filled up two or three months ahead in pig iron and steel products. They were reported to be offering four week's deliveries, but this was only in a special case.

Wrought Iron.

The feature of this week's market has been the rise in price of wrought iron. The Canadian pipe makers have adopted the list established by American makers in January, with a view to having the lists uniform, and on account of increasing weight of pipe. The reduction in discount is due to the continued strength of the steel market.

Structural Steel, Etc.

The teamsters' strike which was settled on Monday night, played havoc with all warehouse business while it lasted. Warehouse stocks of steel were getting low, and dealers could not get at their cars in the yards. Manufacturers are ordering from mill for next year, which looks good for business.

Metals.

Copper opened strong at the beginning of the week, with a steady drop throughout, so that the actual condition on Friday was a 1-4 cent lower than on the previous week. Copper is now selling at 16 cents. There are general inquiries from the States, but business is slack, and little is offered. Tin opened strong, and remained so. Aluminum is not worth more than 21 cents—a drop of 2 cents a pound. The lead market is quiet on this side, while in England it is booming—a strange condition. A fair amount of old material has been offered during the week, and dealers are taking all they can buy at the figures quoted by us this week.

* * *

St. John, N.B., April 21, 1913. — A company has been floated in St. John with a capitalization of \$150,000 to manufacture oil and other internal combustion engines. M. L. G. Vincent, M.E., lately connected with Drummond, McCall & Co., as maritime province manager, has been one of the prime movers in the scheme, assisted by Dr. E. J. Broderiek, of St. John. The provisional directors are Dr. Broderiek, Mr. Vincent, Richard Sullivan, A. E. Massie, and T. J. Terry. Local and outside capital are represented in the concern. The name of the firm is the Oil Motor and Manufacturing Co., Ltd. They have secured the machine shop of J. W. Myers in Waterloo St., and this plant will be used along with other more modern machinery to be installed. An option has been secured on a central site, and later a new factory will be erected. The new company have made arrangements for the manufacture in Canada of a kerosene adapter so that kerosene may be used advantageously in the same engine with gasoline. It is most encouraging to note that crude oil can now be obtained from the shales in Albert County, N.B., at a fairly reasonable rate, and when further tests have been made, the expectation is that oil for engine fuel will be obtainable at a very low price. Arrangements are under way whereby the city of St. John will be provided with an incinerator plant. Commissioner Agar, of the Public Works Department will consider plans in this connection. It is expected that the cost will be at least \$50,000.

* * *

Amherst, N.S.—G. B. Reeser, vice-president and general manager of the Moncton Tramway, Electric & Gas Co., with F. C. Haskell, assistant secretary and treasurer of the same concern, was in Amherst this week in connection with the project of introducing gas for lighting, domestic and power purpose. It is the intention to pipe gas to Amherst

as soon as possible, and although Mr. Reeser could not definitely promise to have the gas pipes laid this season he stated that wherever permanent streets were to be laid in the city during the summer, the necessary pipe lines would also be put down.

* * *

Martin's Head, N.B.—J. A. B. Cowles, of the Pejepscot Lumber Co. was in St. John this week and said that work was being rushed to completion on the company's new lumber mill at Martin's Head, N.B. It will probably begin operation in May.

* * *

Charlottetown, P.E.I.—The Colonial Corporations, Ltd., of Halifax, propose to establish a rolled oats plant in Charlottetown, provided they can obtain certain privileges from the city council. They are asking for a free site, free water, and exemption of taxation for at least ten years. The capacity of the plant will not be less than 300,000 bushels per annum and the company proposes to run the plant day and night. If the necessary arrangements can be made, incorporation will be asked for at once.

* * *

Sydney, C.B.—While in Sydney, C.B., this week, G. Hughes, of London, England who is visiting Canada for the purpose of opening up new fields to capital from the Old Country, made the announcement that that town might soon expect to see the erection of a steel ship-building plant, a traction engine works, and a hat manufacturing industry. The ship-building scheme as outlined by Mr. Hughes involves an outlay of \$5,000,000, and provides a plant capable of building steel ships of any size up to probably 7,000 tons for the freight and coasting service. The smaller craft will include tugs, tenders, etc. Mr. Hughes' visit is occasioned by the investigations carried on by the commission of the British Manufacturers' Association who some little time ago traveled through Canada looking into industrial conditions and possibilities. He represents directly two large trust companies formed for the purpose of expanding Canadian industry, namely, the Imperial Trust Co., and the Anglo-Canadian Industrial Trust Co., of London, England. The principle under which they propose to work is the opening up of Canadian branches of reliable English firms, acquiring the rights of these companies in Canada, and conducting the Canadian concerns on an independent basis.

**SHOE MACHINERY FREE.**

SHOE machinery, now taxed 45 per cent., and on which a reduction to 25 per cent was proposed by the tariff re-

vision bill, was ordered transferred to the free list by the Democratic Caucus of the United States House, on Friday, April 12. It was the first real break of the Democrats from the ways and means committee rates.

For three days there had been a great deal of speech-making from members with and without grievances, but all amendments proposed had been steadily voted down, with majorities satisfactory to the Democratic leaders. The shoe machinery amendment, proposed by Representative Borland of Missouri, and carried by a viva voce vote without substantial opposition from the members of the committee, followed a lively discussion, in which Representative Oglesby of New York, a new member, arraigned the so-called United Shoe Machinery Trust and pointed out the free list as an opportunity to let in competition.

**CAN. GEN. ELECTRIC ABSORBS ALLIS-CHALMERS-BULLOCK.**

MR. Frederic Nicholls, President of the Canadian General Electric Co., authorizes the statement that negotiations have been concluded with the Allis-Chalmers Co., of Milwaukee, and the Allis-Chalmers-Bullock Co., of Montreal, resulting in the acquirement by the Canadian General Electric Co. of all the properties and assets of the Allis-Chalmers-Bullock Co. in Canada, as well as an agreement with the Milwaukee Co., which gives the Can. Gen. Electric Co. the exclusive right to manufacture and sell in Canada the types of apparatus for which the Allis-Chalmers Co. have achieved a reputation, such as Corliss engines, water wheels, sawmill machinery, flour mill machinery, mining machinery, cement machinery, gas engines, etc.

The business will be conducted under the name of the "Canadian Allis-Chalmers, Limited," a charter having been applied for, and Mr. Milne, Manager of the Allis-Chalmers-Bullock Co., will continue as manager of the new concern. The Canadian General Electric Co., with its subsidiary companies, the Canada Foundry Co. and the Canadian Allis-Chalmers, are now in a position to build and equip completely any industrial enterprise, as they manufacture the structural steel required for the buildings; Corliss engines, steam turbines or water wheels for the motive power; boilers, pumps, electric cranes and everything else required for the equipment, and sawmill machinery, flour mill machinery, mining or cement machinery for operation.

INDUSTRIAL ^A_N^D CONSTRUCTION NEWS

Establishment or Enlargement of Factories, Mills, Power Plants, Etc.; Construction of Railways, Bridges, Etc.; Municipal Undertakings; Mining News.

Engineering

Preston, Ont.—The ratepayers have agreed to lend money to the Dominion Bronze Co.

Moose Jaw, Sask.—It is reported that the Toledo Motor Truck Co., Toledo, Ohio, has decided to locate a plant here.

Sydney, N. S.—The Dominion Iron & Steel Co. has an order for 900,000 tons of iron ore to be delivered this year. The first cargo will leave early in April. The first shipment last year was on May 2.

Girouxville, Ont.—The factory of the Steel Equipment Co. to be erected this summer and to cost \$56,000 will be located here on a site between the box factory and the Canadian Northern Railway, comprising six acres of land.

Winnipeg, Man.—C. Schilling & Sons, manufacturers, of St. Paul, Minn., have purchased a site in Elmwood, Man., on which they will erect factory and foundry buildings. The lines to be manufactured here are stoves, ranges, castings, hotel and kitchen outfits.

Brantford, Ont.—The Ham & Nott Co. Brantford, Ont., has decided to still further enlarge its plant. It will erect a new warehouse, 80 x 100 feet, and this will allow much more room for the in-

stallation of additional machinery. There will also be increased power.

Sydney, N. S.—G. Hughes, of London, Eng., representing two trust companies, and forty technical journals, visited this city recently and announced that a shipbuilding firm would erect a plant here at a cost of \$5,000,000. He said also that a traction engine firm would locate here.

St. John, N.B.—The Oil Motor and Manufacturing Co. has been formed, and will make oil engines in this city. The new concern, which will operate the Myers Machine Shop for a while, is capitalized at \$150,000. New machinery will be purchased. The directors have elected Dr. E. J. Broderick president, and Mr. A. E. Massie, treasurer.

Montreal, Que.—Alex. McArthur & Co., Ltd., paper makers, are going to erect a new plant here, the railway having bought the site of their present place. They will be in the market shortly for two 125-h.p. boilers and other equipment, including that for a small machine shop. This company is also going to instal a new power plant at their place in Joliette.

Sydney, N.S.—The Cape Breton Electric Company is shortly to erect a

power station at Reserve Junction, N.S., in which will be installed a powerful generator to furnish the necessary power for the Sydney and Reserve ends of the tram service. As soon as this large plant is installed the smaller plant in commission at Dominion for the last four years will be dismantled.

Ottawa, Ont.—The Campbell Steel and Iron Works is doubling the size of its plant. Their product embraces steel bridge work, steel building construction and architectural work. The plant occupies six acres of land on Carling Avenue, and is now running to the limit of its capacity. W. J. Campbell is the president, A. Campbell vice-president and general manager, and H. G. Campbell secretary-treasurer.

Medicine Hat, Alberta.—The Industrial Iron Works, Ltd., makers of roll grinding and corrugating machinery for flour and paper mills, will build a plant on a site of 1½ acres. The machine shop, measuring 40x80 ft. will be put up first, and will be followed later by a foundry. About \$20,000 will be spent in machinery and \$10,000 in buildings, the concern being capitalized at \$40,000. The plant will be ready in two months. Joseph W. Hamilton, of Medicine Hat, and Floyd T. Richfield, formerly a ma-

CANADIAN BOVING CO. PLANT AT LINDSAY, ONT.

The Canadian Boving Co., hydraulic engineers, 164 Bay St., Toronto, have purchased the factory of the Madison-Williams Co., Lindsay, also twelve acres of land adjoining same, on which they will build extensions to treble the size of the present plant. They will do this on condition that the ratepayers of Lindsay furnish a cash bonus of \$10,000 to assist in the additional property purchase and that the property will be exempt from all municipal taxation, but not from school or local improvement taxes. The agreement with the town calls for the employment, if these conditions are

fulfilled, of not less than sixty men, but Mr. Clayton, manager of the Canadian Boving Co., states that 150 men will be employed as soon as this matter which will be submitted to the electorate on April 28th, has been settled. The new owners will be in the market for new machine tool equipment.

At their new plant the Canadian Boving Co. will manufacture turbine water wheels, pumps, pulp and paper machinery, in fact they will manufacture in this plant ultimately all the machinery required for their business in Canada. The Madison-Williams plant

as it exists at present is not large enough.

The parent factory of the Canadian Boving Co. is at Carlstadt, Sweden, where they commenced business in 1873, on papermaking machines and turbine water wheels. In this plant they employ about 800 men. They have now a capital of \$650,000, and are well known as an enterprising and up-to-date firm, both here and in Europe. They have also plants in England and in Germany. One hundred thousand dollars will be spent on improvements at the Lindsay plant.

LAWSON & JONES LIMITED
LITHOGRAPHED

The James Robertson Co. Limited
TORONTO

April 11, 1913.

The General Fire Equipment Company, Limited,
72 Queen St. East,
Toronto, Ont.

Gentlemen:

We have much pleasure in advising you that we have been very well pleased with our investment in connection with the installation of Automatic Sprinklers in our new building.

Shortly after moving into the building, we had a small fire which was extinguished almost instantly by the discharge of three Sprinklers.

The rate of insurance which we are able to effect thro having Sprinkler Equipment has made the investment a good one for us.

Yours very truly,
THE JAMES ROBERTSON CO., LIMITED.
J.S. Robertson
MANAGER.

General Fire Equipment Company, Limited
Sole Agents of
"McBrine's Around-the-World-Baggage"
Berlin, Canada

W.E. SANFORD
MANUFACTURING COMPANY LIMITED.
Hamilton, Ont.

Unanimous!

The letter reproduced herewith is typical of scores on file from prominent manufacturers expressing their entire satisfaction with

Manufacturers Automatic Sprinklers

The majority state that the saving in insurance has paid the cost of installation in from three to four years. Any "might-have-been" fires were extinguished at once. The same thoroughly satisfactory system should protect your plant.

The General Fire Equipment Co., Limited
72 Queen St. East, Toronto, Can.

W.P. Hamilton Shoe Co. LIMITED
BOOTS, SHOES AND RUBBERS.
15 & 17 FRONT ST. EAST.
Toronto.

CASTLE STEEL CASTINGS

Heavy Castings Up To 20 Tons
Locomotives, Engine Frames, Wheel Centres
and Machinery Castings Our Specialty.

Stock Process Steel for Automobile and Light Castings of all Descriptions.

Prompt Deliveries.
(Annual Capacity, 12,000 tons.)

Let us figure on your requirements.

The Dominion Steel Castings Company, Limited
HAMILTON, ONTARIO

chemist in Macleod, are interested. New equipment will be bought.

Electrical

Hull, Que.—City Engineer Laforest will install larger electrical machinery in the city pumphouse.

Stratford, Ont.—Lighting and general equipment is to be purchased for the new extension to Sebringville. Superintendent, R. H. Myers, electrical department.

Vancouver, B.C.—Mackenzie & Mann, closely connected with the Canadian Northern Railway, are figuring on extensive hydro-electric developments along the Fraser River in British Columbia. For some time past, they have been active in securing water rights.

Le Pas, Man.—Several firms are now tendering on the contract to erect the wireless station to be built here at an early date in connection with the construction of the Hudson Bay Railway. A. E. Reoch, secretary-treasurer and chief engineer of the Canadian Marconi Telegraph Co., of Toronto, and Walter A. Rash, of the radio telegraph branch of the department of naval service, Ottawa, were recently here.

Waterworks

Stafford, Ont.—The ratepayers on April 21 agreed to spend \$11,546 on sewers.

New Westminster, B.C.—The city is borrowing \$200,000 for extensions to waterworks.

Brandon, Man.—The city will construct 44,155 feet of sewers, costing \$104,155.

St. Thomas, Ont.—The city will spend \$100,000 on an extension to its waterworks system.

London, Ont.—Engineer Chipman's report on the storm sewer survey shows that the cost will be \$392,000.

Woodstock, Ont.—The Water and Light Commission will raise \$12,000 for new works, including renovation of mains.

Municipal

Sydney, N.S.—The city is considering the construction of an incinerator.

Wingham, Ont.—A by-law to raise \$6,500 to purchase road making machinery will shortly be submitted to the burgesses.

Prince Albert, Sask.—Fire apparatus to cost \$30,000 will be purchased by the city council. Clerk, C. O. Davidson. Fire Chief, Ald. G. Wagner.

Fernie, B.C.—Recently the burgesses voted in favor of the by-law to raise \$10,000 for the purpose of extending the electric light system of the city.

Toronto, Ont.—Following the recent trouble with the water supply, Works Commissioner Harris has estimated the cost of another 4-ft. pipe across the bay at \$300,000.

Port Coquitlam, B.C.—An 18-foot paved road from Vancouver to Pitt River is proposed at a cost of \$30,000 a mile. Port Moody, Burnaby and Coquitlam will be on the route.

New Westminster, B.C.—City Engineer Blackman has completed plans for No. 1 and No. 2 sections of the Sapperton sewerage scheme. Burnaby has agreed to pay \$150,000 of the cost.

Dryden, Ont.—The following by-laws will come before the ratepayers on May 3: \$2,500 for a telephone system and to raise \$6,000 for the purpose of acquiring an electric light system.

Berlin, Ont.—The city council on April 14 passed a by-law authorizing the construction of a new trunk sewer, which it is estimated will cost in the neighborhood of \$70,000. It will be a 48-inch main, and according to estimates will supply the needs of the city until 70,000 population is reached.

Toronto, Ont.—The Provincial Legislature has granted to the city the power to acquire the Toronto Street Railway Co.'s stock. The estimated cost to do this is placed at \$21,000,000. The city has also the option of buying out the Toronto Electric Light Co. No figures are available as to estimated cost of this latter.

Stratford, Ont.—At a special meeting of the city council recently, May 8th was set as the date for voting on a by-law to loan the Stratford Mill Building Co., \$30,000 and grant a fixed assessment of \$12,000 for ten years, in return for the company erecting a \$60,000 plant for the manufacture of flour mill machinery, to replace the factory destroyed by fire last December.

General Industrial

Souris, Man.—McCulloch & Sons millers, are installing new machinery at a cost of \$15,000, thus doubling their capacity.

Weyburn, Sask.—The Weyburn Brewing Co. is preparing to build a brewery

here. The trustee of the firm is Thomas H. Hillier.

Mission City, B.C.—The Empress Mfg. Co. have purchased a site for a jam factory, and will move here from Vancouver.

Swan River, Man.—The Imperial Oil Co. warehouse at this point caught fire on April 10. The gasoline exploded shattering the heavy galvanized building to pieces.

Montreal, Que.—The Canadian Connecticut Cotton Co., whose mill will be located at Sherbrooke, expects to commence operations before the close of the present year.

Chelsea, Que.—The International Paper Co. has plans for the erection of a large paper mill. Some time ago this company secured an option on power rights at Chelsea.

Peterborough, Ont.—The ratepayers seem to favor granting a free site and exemption for ten years to the Vermont Marble Co., who will spend \$20,000 in buildings and machinery.

Montreal, Que.—Factory of Paterson Mfg. Co., makers of roofing paper, 2021 St. Hubert street, was recently burned. Supt., Harry F. Childs. The building will be repaired at once.

Tillsonburg, Ont.—The Snedcor & Hathaway Co., of Detroit, shoe manufacturers, are asking for concessions. They will build a plant costing \$15,000, and move their machinery here.

Brampton, Ont.—A Toronto firm is in negotiation with Messrs. Robson & Lowe for the purchase of their farm. The company will manufacture glue, and will give employment to 50 hands.

Montreal, Que.—The city is having a new refrigeration plant installed at Bonsecours Market. It will supply cold storage to the tenants at a charge of one cent per cubic foot per month.

Moose Jaw, Sask.—Announcement is made through the Board of Trade that the Tripure Water Co. of Canada, under the management of W. A. Lewis, will locate at 121 River street west, in this city.

Harcourt, Ont.—The New York Graphite Co. will erect a refining plant at Harcourt, Ont. The works will have a capacity of 100 tons of ore per day of 24 hours, and will require the employment of 50 men.

Calgary, Alta.—Charles H. Peth, of the Peth Candy Co., Wausau, Wis., has contracted for 10,000 ft. of space in the new industrial building to be built here. Mr. Peth will employ about 60 hands to start with, and this number will be doubled later.

BOILERS

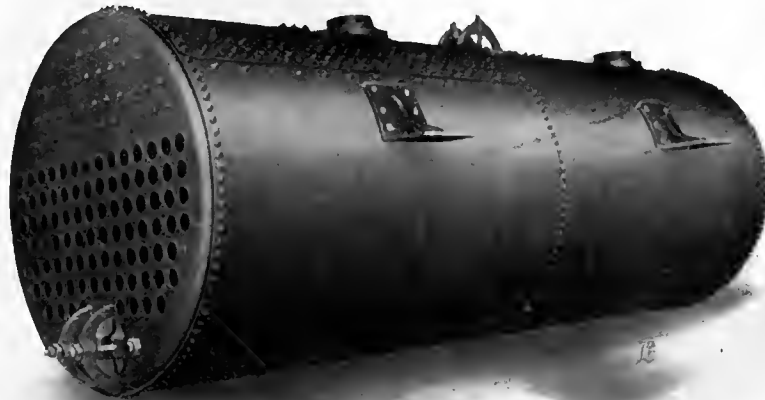

“Inglis” Boilers—“A Product Without a Peer”

Every boiler before it leaves our shops is subjected to the most rigid inspection, in fact every feature is most carefully watched in the manufacture, our constant aim being to make “INGLIS” Boilers safe, durable and economical.

Write Us For Prices.

THE JOHN INGLIS COMPANY, Ltd.

Engineers and Boilermakers

14 Strachan Ave.

TORONTO, CAN.

Brantford, Ont.—For the encouragement and housing of infant industries, a syndicate has been formed here which will build three factory buildings for rental. The Greater Brantford Board proposed the scheme, which has been taken up by local capitalists. An expenditure of \$30,000 is planned on the first building.

Thorold, Ont.—The Beaver Co., Ltd., are breaking ground for a mill and factory at Thorold for the reduction of timber and the manufacture of Beaver board. The plant will cost between \$300,000 and \$400,000. A total of 6,000 horse-power will be required in addition to 500 horse-power which will be used for the treatment of fibre. All equipment is required.

St. John, N.B.—The announcement was made last week that New Brunswick Shales, Ltd., with which Sir William Mackenzie is connected, will begin, as soon as the weather permits, a more extensive development of the oil shales in Albert County. It is the purpose of the company to erect a large reduction plant, which will involve an ultimate expenditure of several million dollars. Another result will be the rise of a new town, if not more than one, in that section of Albert County. The Maritime Oil Fields, Ltd., will continue their development work in the natural gas and oil fields in Albert and King's Counties.

Wood-Working

Scotstown, Que.—A company is being organized to erect a chair factory. M. G. Scott is one of those interested.

Gananoque, Que.—A paper box factory is planned by the Booth Felt Co. to be combined with the manufacture of felt.

Grand Mira, N.S.—Chappell Bros., of Sydney, are erecting a saw mill. The work of laying a concrete foundation for this structure is now going on.

Megantic, Que.—The factory of the Megantic Furniture Co. was burned recently. The loss is estimated at \$50,000. The plant will be re-built.

Winnipeg, Man.—Nelson & Foster, 1398 Erin street, are having plans prepared for a sash and door factory on William avenue, near Arlington street.

Toronto, Ont.—A fire at the planing mill of S. R. Hughes, 79 Portland Street, on Monday caused damage to the extent of \$2,500. The loss is covered by insurance.

Lake Megantic, Que.—P. Cliche, of Beauce Junction, will establish a broom and brush factory in Megantic. The

town has lent him \$7,000, and exempted him from municipal taxes.

Cookshire, Que.—The Cookshire Furniture Factories, Ltd., will build a plant here to manufacture bedroom furniture, and will employ 50 hands and pay \$25,000 annually. The town has guaranteed their bonds.

Merriton, Ont.—The Riordan Pulp & Paper Co. announce that their Merriton sulphite plant will be rebuilt and in operation by the first of June. The company will also have their eighth digester—a new one—cooking pulp at Hawkesbury about the 1st of May.

Walkerton, Ont.—R. Trnax & Son, are drawing up plans for a one-storey sash and door factory. The building will be 300 feet long x 60 feet wide with cement foundations and a cement floor 10 inches thick. The walls will be of brick 12 feet high. The factory will provide more room than the company have in their present place, and will enable them to have all their machinery and workmen on one floor.

Building Notes

Toronto, Ont.—The Federal Government will build an enlarged Post Office and a Customs Office costing \$2,000,000.

Saskatoon, Sask.—A \$250,000 building on 3rd Avenue and a \$60,000 building on the same avenue are on the building programme.

Victoria, B. C.—Messrs. Rockfort & Sankey, architects for the directors of the Victoria Opera House Co., will call for tenders for the construction work of the theatre.

Outremont, Que.—The Board of School Commissioners will erect a building in Champagnour and Lajoie Streets to be known as St. Madeleine School. It will be 180 x 186 feet. The contractors are Ulrice Boileau & Bros.

London, Ont.—McBride & Gilbert, architects, have been awarded the contract to prepare plans for the new Jones Lithographing Factory, which is to be built in East London. The factory is to be one-storey and basement, of "Milton" special brick, and will be 160 feet long. It is expected that the plans will be ready in about a week, and that the contract for the work will be then let.

Railways—Bridges

Toronto, Ont.—Estimates for both steel and concrete for the Bloor Street Viaduct will be called.

Toronto, Ont.—The Niagara Park Commission, of which P. W. Ellis, of Toronto, is vice-chairman, will grant a concession to a Spanish company for the installation of an aerial tramway over the whirlpool at Niagara Falls.

Vancouver, B.C.—It is possible that tenders for the construction of the Second Narrows bridge will be opened by the directors of the Burrard Inlet Bridge and Tunnel Co. about the end of June. This statement was made by Secretary J. Y. McNaught.

Montreal, Que.—The Grand Trunk statement of rolling stock received during the month of March shows: From the Montreal Locomotive Works, 1 Pacific type 73-inch wheel engine; from the Canadian Locomotive Co., 3 switch engines, 20-inch by 26-inch cylinder; from the Pressed Steel Car Co., McKee's Kocks, Pa., 55 box cars.

Contracts Awarded

Broughton, N.S.—Rhodes, Curry and Co. will immediately commence the erection of ninety houses for workmen, the contract for which they secured some time ago.

Halifax, N.S.—The contract for supplying coal at Sorel, Three Rivers and Quebec for Government purposes for the season of 1913, has been let to the Nova Scotia Steel and Coal Co.

Montreal, Que.—The parish of Sault au Recollet has awarded a contract for five miles of bitulithic road extending two miles and a half each way from the present terminus of the Montreal Tramway, opposite St. Vincent de Paul. The work is to be done by M. J. Stack & Co., of Montreal.

Sarnia, Ont.—The Imperial Oil Co., has awarded its contract for the construction of a new freight shed at the mouth of the river at Fort William, Ont., to S. J. McQueen, of Fort William. The new shed, 50 x 400 ft., will be constructed of corrugated iron, and will be fitted with all modern appliances. The company now employs about 50 men.

New Westminster, B.C.—The contract for the construction of the new ferry boat for the West Vancouver Ferry Company Limited has been awarded to Captain Wessel of Vancouver. The boat will be 80 feet in length, with a beam of 15½ feet, and will be equipped with the latest type Atlas engines, 80 h.p. The contract is dated April 2nd, and calls for the delivery of the boat on June 11th.

Winnipeg, Man.—Eighteen contracts have been awarded by the Canadian Pacific Railway, including that for

Handling Heavy Machines and Their Parts Under the Crane*

By John Riddell**

The importance of the subject here dealt with, is, we believe, fully realized by those responsible for the management and operation of machine and erecting shops, foundries, etc.; at the same time, all of us need to be reminded, if not re-informed, concerning our work and the manner of its production, and to those who are responsible for the lifting and transportation of machine parts from department to department of our factories, this descriptive article will be found of the highest value.

THE handling of heavy machines and parts of machines in a large electrical factory is a matter of the greatest importance. The apparatus used includes traveling cranes, jib cranes and other machinery; and, during the ordinary working day, has to deal with weights varying between very wide



30 DEGREE ANGLE SLING, WRONG WAY.

limits. The different cranes may vary in capacity from, say, 3 tons to 100 tons, and the weights of the pieces which have to be handled may be anything from 100 lbs. to 100 tons.

As a general rule, no particular trouble need be expected in handling the larger weights, since, owing to their importance, more care is exercised in making hitches and other preparations, and usually the foreman, or some other leading man, sees that all accident is guarded against. It is from pieces of medium and light weight, of which a great many are handled every day, that trouble more often results. The man handling so much of this class of work becomes thoughtless, the slings become chafed and worn, while the chains become crystallized by long use. The last is a frequent cause of trouble.

Ropes and Slings.

There is a great difference between ropes and slings used for hoisting. In ropes, the wear can always be seen by the strands becoming frayed, loose or

cut. A chain, on the other hand, outside of a few bruises, will not show any signs of weakness; although actually it may be full of small cracks, which cannot be detected by the naked eye, or it may be much crystallized by long use. A chain under these conditions rapidly becomes weaker with each lift, until it finally gives way, letting something fall on the man who used it, or, as is more frequently the case, on some innocent shopmate.

Care of Chains and Slings.

Whether anyone is hurt or not, there is always a loss to the factory. Sometimes it may only be a rough casting, but very often it is a piece of finished apparatus on which much time and labor have been spent; and, worst of all, there is usually urgent need for the apparatus at its destination, involving disappointment. Suitable racks should be provided for hanging chains and slings, and, when not in actual use, they should be kept there. When not employed attending to lifts, the followers should be inspecting these slings, in order to detect weakness and sort out those which are bad, so that they may be repaired. These racks also afford a ready means

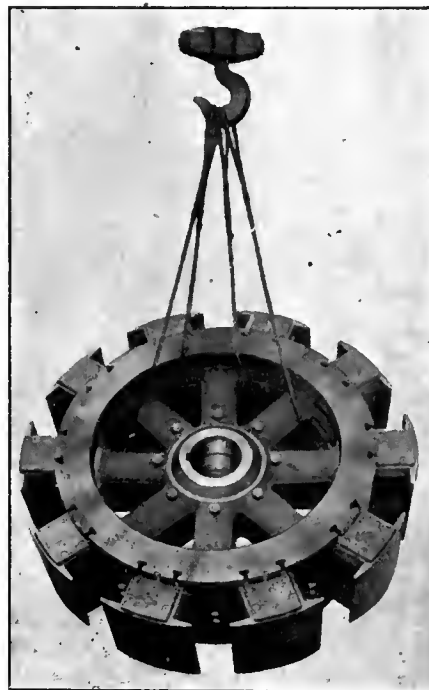

PROPER METHOD OF MAKING HITCH FOR TURNING REVOLVING FIELD. STRAIN BEING EQUALIZED.

for the head rigger's inspection, who is in charge of all such apparatus, and who should always be consulted when anything of a doubtful character in relation to hoisting comes up.

There are many varieties of hitches and many kinds of knots. Some are useful, others are ornamental; only the

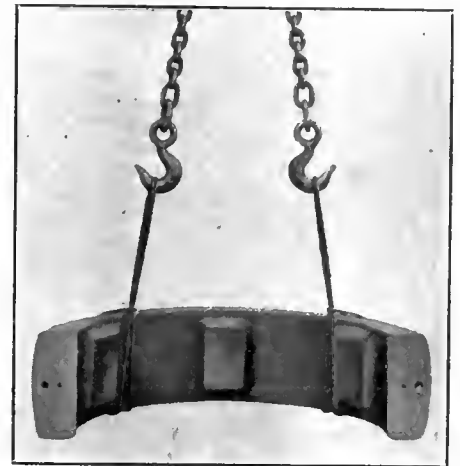

PROPER METHOD OF MAKING HITCH. THE FRICTION OF CABLE AROUND THE OBJECT GIVES APPROXIMATELY A TWO PART CABLE.

useful kind will be considered here. Some knots and hitches are shown for use in special cases only, not being intended for everyday service in machine shops. They are useful, however, for riggers, millwrights and others handling special machinery and materials, and should be used only by men competent in such work.

Wire Cable Slings.

Wire cable slings occupy a very important place in hoisting, and have been found very satisfactory when carefully used. A wire cable sling should never be used singly when hooked by a spliced eye. When the weight is sufficient the cable is likely to untwist, thus allowing the splices to open and slip. Such slings should always be used double, and where sharp corner or rough castings exist, the cable should be protected by pads, as shown in Fig. 2. Another method of protecting the cable is by two loose metal blocks that should be perfectly free to adjust themselves and afford ample protection for the slings so used.

In using slings of any kind, especially

*Abstracted from the "General Electric Review."

**Mechanical Superintendent, Schenectady Works, General Electric Co.

rope, care should be taken to see that they are properly laid: that is to see that one rope does not lie on top of the other, as this will prevent proper equalization, putting an undue strain on the outer rope. It very often happens, when a rope sling is used double, that the ends of the rope are passed through the

Sudden Stoppage of Load.

Before lifting heavy loads by means of a crane, the crane brakes should always be tested to see that they are in good condition, and that they will hold. Care must be used when lowering loads to limit the speed, which should not exceed the hoisting speed of the crane for

the load at such speeds within a distance of $\frac{1}{8}$ in. may double the stress on the slings and crane.

This point cannot be emphasized too strongly; as, in more than one instance, serious accidents have resulted from the sudden stopping of cranes while the load was being lowered.

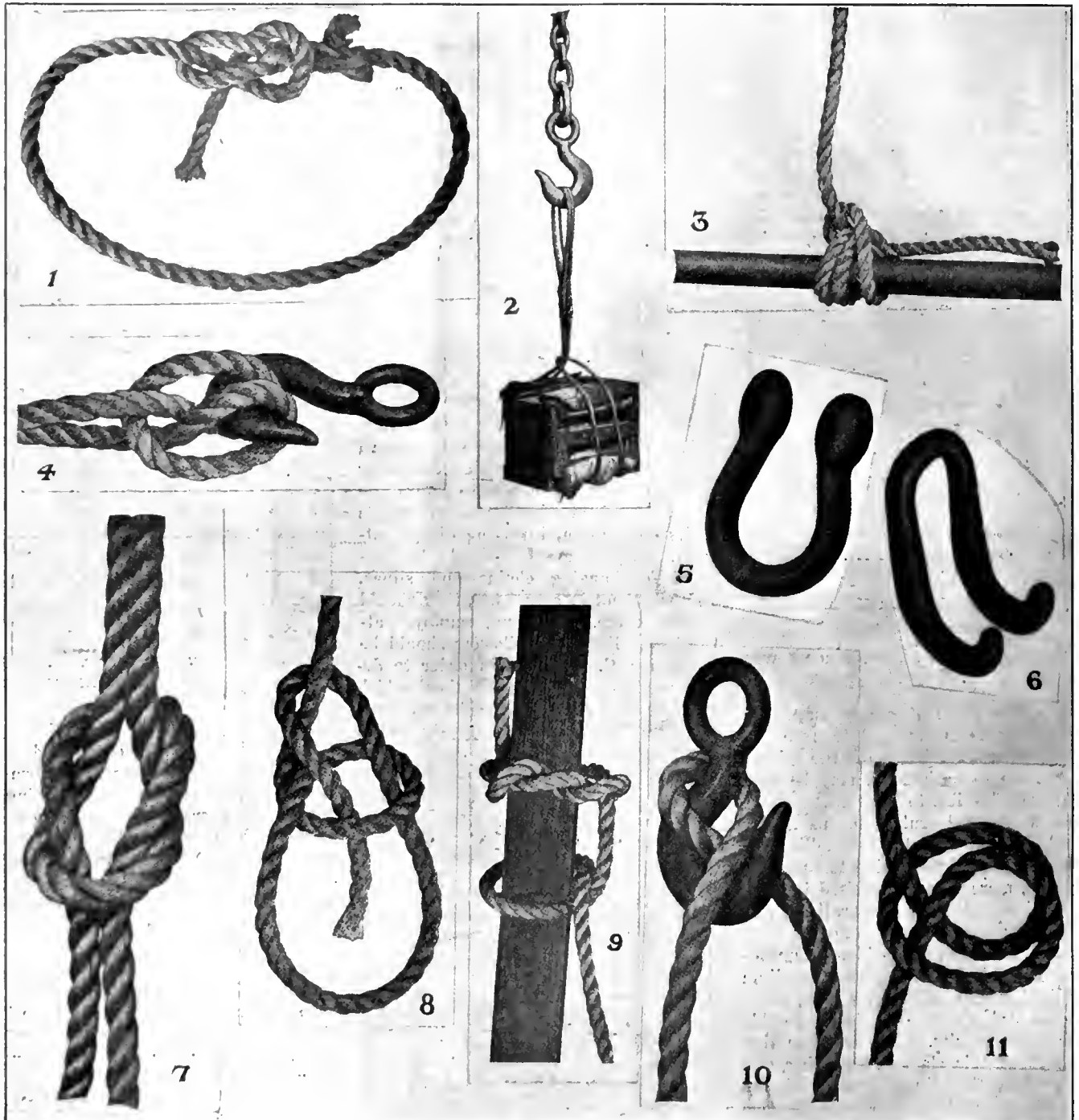

FIG. 1. SHEET BEND IN EYE. FIG. 2. DOUBLE CABLE SLING, RIGHT WAY TO LIFT LOAD. FIG. 3. STUDDING SAIL HITCH. FIG. 4. CLOVE OR DOUBLE HALF HITCH. FIG. 5. SHACKLE. FIG. 6. DOUBLE HOOK. FIG. 7. SQUARE OR REEF KNOT. FIG. 8. BOWLINE COMPLETE. FIG. 9. TIMBER HITCH AND HALF HITCH. FIG. 10. BLACKWALL HITCH. FIG. 11. CLOVE OR DOUBLE HALF HITCH.

doubled part, as when placed around a casting: and, unless this is done carefully, instead of having the strength of two parts of a rope, as supposed, it can be so slipped around the casting, or other piece being lifted, as to actually only have the strength of one part.

the same load, and particular care must be taken to apply the brakes gradually when bringing the load to rest. The ordinary hoisting speed for a 30-ton motor-operated crane is about 18 ft. per min., and for a 50-ton crane about 12 ft. per min. with the rated load. Stopping

When a weight is lifted by two or more slings connected to the crane hook and making an angle with each other, the increase in the stress of the individual slings must be considered. On account of this angle between the two sets of slings, the stress on each set is

greater than half the total load, and increases very rapidly as the angle between the sling and the work is decreased. An angle of 45 deg. between the sling and the work makes the stress in each sling three-fourths of the total weight, and the collapsing force be-

A spreader of sufficient stiffness should be used between these two points to resist this collapsing force. It will be seen that eye-bolts are not suitable for attaching the slings to the work unless a spreader is used to relieve them of this side pull, which would put a

small angle should never be used if avoidable.

Safe Loads for Eye-Bolts.

When it is necessary to use eye-bolts for lifting loads, no greater strain should be allowed than given in Table 1, which gives the safe load in pounds for

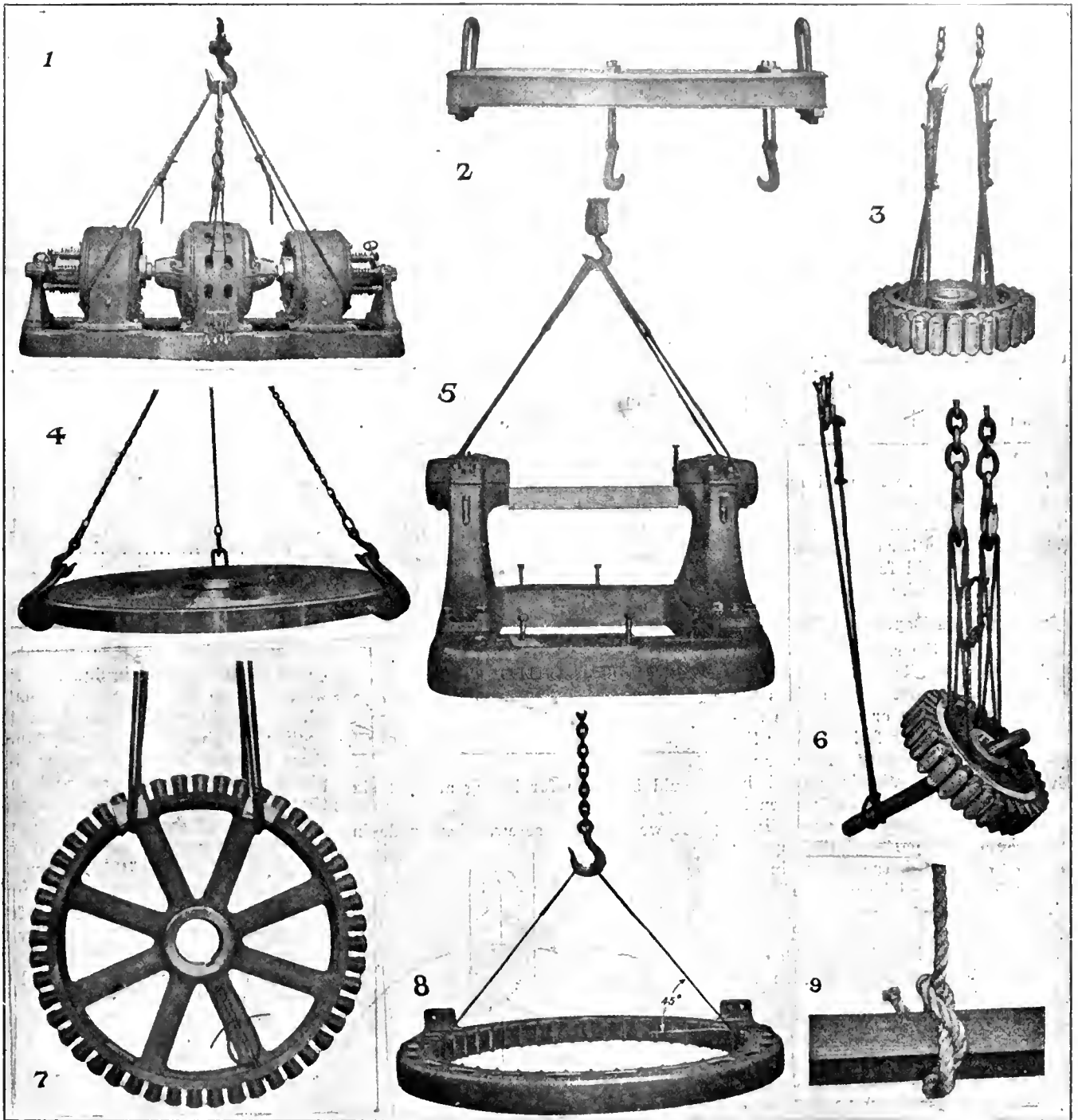

FIG. 1. PROPER WAY OF LIFTING THREE UNIT SET. FIG. 2. EQUALIZER USED WITH TWO CRANES. FIG. 3. METHOD OF LIFTING AND TURNING REVOLVING FIELDS, FIRST POSITION. FIG. 4. RIGHT WAY OF LIFTING PLATE WITH THREE HOOKS. FIG. 5. METHOD OF LIFTING BASE AND STANDARDS. FIG. 6. METHOD OF LIFTING AND TURNING REVOLVING FIELDS, SECOND POSITION. FIG. 7. RIGHT WAY TO LIFT REVOLVING FIELD. FIG. 8. 45 DEGREE ANGLE SLING, RIGHT WAY. FIG. 9. TIMBER HITCH.

tween the two points of attachment to the work is equal to half the weight. This collapsing force acts in a direct line between the two points of attachment. If the work is ring-shaped, it would tend to deform the ring.

heavy bending moment on the shank of the bolt. Reducing the angle between the sling and the work to 30 deg. makes the stress in each sling equal to the total weight, and the collapsing force is also equal to the total weight. Such a

bolts up to and including 2 1/4 in. diameter. It should be noted that the values given are correct only when the pull is in the lengthways direction, and when the bolt is in good condition.

It should further be understood that,

to obtain the greatest strength from an eye-bolt, it must fit reasonably tight in the hole into which it is screwed, and the pull applied in a line with the axis of the screw. Eyebolts should never be used if considered the least faulty. They should never be painted when used for miscellaneous lifting, as paint is very apt to cover up flaws. They should be tested occasionally by tapping gently with a hammer, but not sufficient to bend or to otherwise injure them. If they do not impart a good ring there are one or two good reasons—they may fit loosely in the hole, or there may be a flaw in the material.

table of the weights of the various materials is given in Table 3. The weights of cast-iron, steel, copper and lead are given in pounds per cubic foot. The weights of wood, concrete, stone, earth,

the form of an eye-bolt, should never be used on which to hang any hoisting tackle. Whenever possible, the safest way to hang such tackle is by passing the shank of an eye-bolt through a floor or beam, properly protecting the wood by a large plate washer and nut. It frequently happens that a chain or rope sling can be used by passing it over a properly secured timber. There are several good ways of doing things, and many wrong ways. Care should always be used to see that they are done in a good way.

Generalities.

Case after case might be enumerated; but enough has been said to enable any person entrusted with this work to be able to decide on a proper method, and

TABLE 1—EYE BOLTS.
—INCHES—

Drop forged steel	SAFE LOAD LB.		
	A	B	C
D.B.G. Iron E.L., 28,000 Lb. per sq. in. Welded	1/2	1 1/2	7-16
	9-16	1 9-16	17-32
	5/8	1 11-16	3/4
	3/4	1 13-16	3/4
	7/8	1 15-16	13-16
	1	2 1-16	15-16
	1 1/4	2 5-16	1 3-16
	1 1/2	2 9-16	1 3/8
	1 3/4	3 1-16	1 1/2
	2	3 1-16	1 5/8
1 3/4	3	1 1/2	
1 3/4	4	1 1/2	
2	5	1 3/4	
2 1/4	6	2	

Where a bolt is to be used for anything like its maximum load, it should be screwed in tight with a bar and given a gentle tap with a bar or hammer to see if it imparts a solid feeling; otherwise, it should not be used.

Safe Load on Ropes and Chains.

Table 2 gives the safe loads which may be put on manila rope, wire cables, and chains. The first column gives the diameter of the rope or chain, the second column gives the safe load which the rope or chain is to carry singly. In a sling, where the strain is carried by two ropes or chains, the loads given in the third column should be used. In a sling, where four parts of the rope or chain carry the load, the figures in the fourth column should be used. Figures are in tons of 2,000 lb. each. The loads for manila rope should be used only when the rope is in fairly good condition; when badly chafed or worn the load should be reduced.

As there are a great many different kinds of material to handle in the various parts of a factory, and in order to familiarize those engaged in the actual handling of these materials, a short

brick, mortar and marble are also given in pounds per cubic foot.

A great deal of shafting is also handled. The weight of shafts is given per lineal foot, or so many pounds per each foot in length. All that is then necessary in order to find the weight of any piece of shafting, knowing the weight per foot, is to multiply the weight by the number of feet in length, which will give the net result in pounds to be lifted. For instance, a piece of shafting 16 inches in diameter, and 1 foot long, weighs 676 lbs., and a piece of shafting of this same diameter and 16 ft. long would weigh 10,816 lbs. Provision in this case

TABLE 3—WEIGHTS OF VARIOUS MATERIALS.

Material—Metals.	Weight per	
	Cu. ft. in lbs.	Cu. in. in lbs.
Cast iron	450	0.28
Steel	480	0.28
Lead	700	0.41
Copper	552	0.32
Material—Wood.		
Asb	45	
Pine	38	
Material—Miscellaneous.		
Concrete	155	
Stone	180	
Earth	72 to 110	
Brick	100 to 150	
Mortar	100	
Marble	180	

SHAFTS.

Inches Diameter.	Weight in Lbs. per Lineal Ft.
6	95
8	169
10	264
12	368
14	517
16	676

TABLE 2.
WIRE CABLE—SAFE LOAD IN TONS.

Dia. of Cable in In.	Single	Two Part	Four Part
1/2	1	2	3 1/2
5/8	1 1/4	2 3/4	4 1/2
3/4	2 1/2	4 1/2	6 1/2
7/8	3 1/4	6	9
1	4	8	12
1 1/4	6	12	16
1 1/2	10	19	24
1 3/4	13	25	36
2	16	32	48
			60

should be made for lifting at least six tons.

A wood or lag screw, when made in

the proper slings or other apparatus to be used. Where he is in doubt as to the weights to be lifted or methods employed, he should seek advice from those qualified to give it. For the guidance of those engaged in handling or lifting pieces, it is also suggested and urged that all irregularly shaped castings, and in fact, all castings weighing over a ton, should have the gross weight marked in plain figures. It is always safer to overestimate a weight than to underestimate it; and it is always safer to use slings of ample lifting capacity than those about which one is in doubt.

Other defects besides those in lifting apparatus will occasionally be discovered, such as a cracked arm of a fly-wheel, or other similar piece. If this

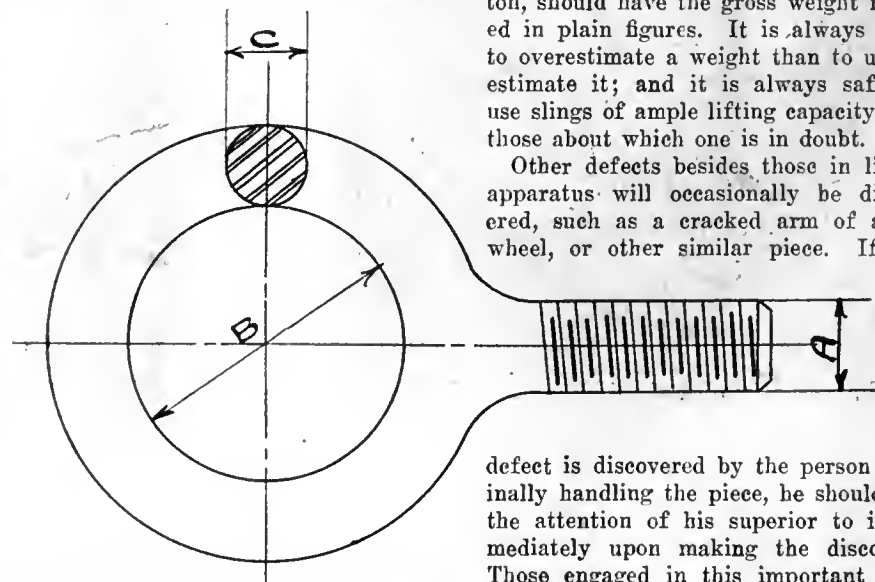

EYE-BOLT—PROPORTIONS PER TABLE 1. PULL SHOULD ALWAYS BE IN DIRECTION OF STEM AXIS.

defect is discovered by the person originally handling the piece, he should call the attention of his superior to it immediately upon making the discovery. Those engaged in this important work should also have some idea of the strength of materials.

TABLE 2.
MANILA ROPE—SAFE LOAD IN TONS.

Dia. of Rope in In.	Single Rope.	Two Part.	Four Part.
1/4	1/4	3/4	1 1/2
5/8	3/4	1 1/2	2 1/2
3/4	1	2	3 1/2
7/8	1 1/4	2 1/2	4 1/2
1	1 1/2	3	5 1/2
1 1/4	2	4	6 1/2
1 1/2	2 1/2	5	8 1/2
1 3/4	3 1/2	6 1/2	11 1/2
2	4 1/2	8	13 1/2
2 1/4			
2 1/2			

They should know how the strains will be set up in such materials, and also how to apply slings for lifting, as variously illustrated here. They should know that using too small an angle on the slings, as in the case of a field ring, would tend to pull the sides together; and that, in the case of a revolving field, where the sling is applied between a pair of arms instead of around adjacent arms, the tendency would be to break out a portion of the ring.

These things are all matters of judgment, and the importance of appointing proper persons to take charge of this work cannot be urged too strongly. A reduction in the number of crane accidents can only be effected by extreme vigilance. The loss of material in the past has been very great, and the suffering to humanity caused by thoughtlessness has been as great. If proper care is exercised, such accidents can be almost totally avoided.

the amount of deflection. It is necessary then to reduce the belt tensions as much as possible, and the only way to do this efficiently is to properly treat the belt.

Leather Belting Features.

Since leather belts are made up entirely of small fibers, it is the action

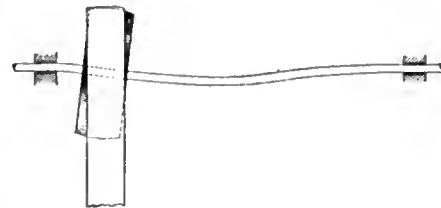

FIG. 2. EXAGGERATED EFFECT OF A TIGHT BELT.

Power Transmission Benefited by Belt Treatment

By C.T.R.

It cannot be too forcibly impressed on the minds of users of belting that proper treatment of and consideration for this drive medium, not only prolongs the life, and, therefore, reduces the upkeep cost, but at the same time reduces the operating expense by eliminating abnormal friction and reclaiming lost work.

PROF. Thurston, the great authority on friction and transmission, says in his book "Friction and Lost Work" that the power loss in mills and shops ranges from 5 to 70 per cent. Kent quotes a loss of 25 to 39 per cent. of the total power in the shafting alone. It is the duty, therefore, of the engineer and belt man to cut down these losses as much as possible by proper lubrication and adjustment of bearings, by proper alignment of shafting, and by proper care and maintenance of belts and pulleys. The most important item of them all is the belt, because, where wear in bearings is excessive, it is usually due to tight belts. Again, where shafting is unduly sprung, a belt is usually the

with ordinary bearings would transmit power a distance of 6,000 ft. with an efficiency of 80 per cent., when all forces are purely torsional. With belts, in which bending and torsion are necessarily combined, that distance drops to 400 ft.; still 400 ft. is a much greater distance than is accomplished by shafting under ordinary conditions with efficiency of 80 per cent.

Many belt drives are arranged as shown in Fig. 2, with only one hanger to give rigidity to the driven pulley. In

of the fibers that must be studied. As soon as understood they can be given intelligent protection. When anything is bent, internal friction is brought into play somewhere. This is proved by the increase in temperature of rods while bending. When a belt is bent, every fiber is forced to rub against its neighbor. It is the fibrous construction of a leather belt that makes it porous. These pores or spaces may be easily filled with any fluid substance, and unless first treated on the outside and well filled with some substance that resists moisture, the latter will easily get in and out. Alternate wetting and drying shortens the life of any kind of leather, as wearers of leather shoes or gloves well know. When proper treatment is ap-

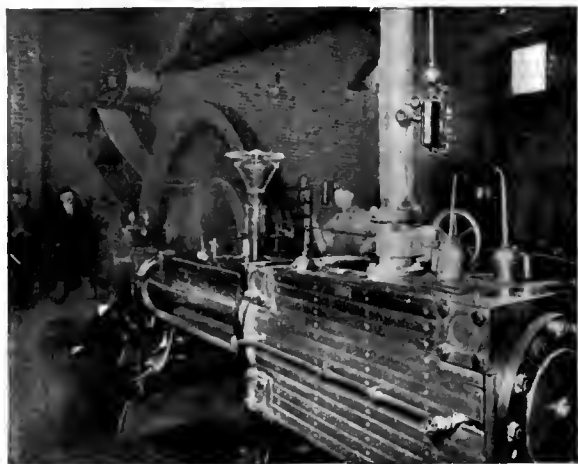

FIG. 3. TYPICAL EXAMPLE OF BELT DRIVE UNDER NON-SLIP TREATMENT.

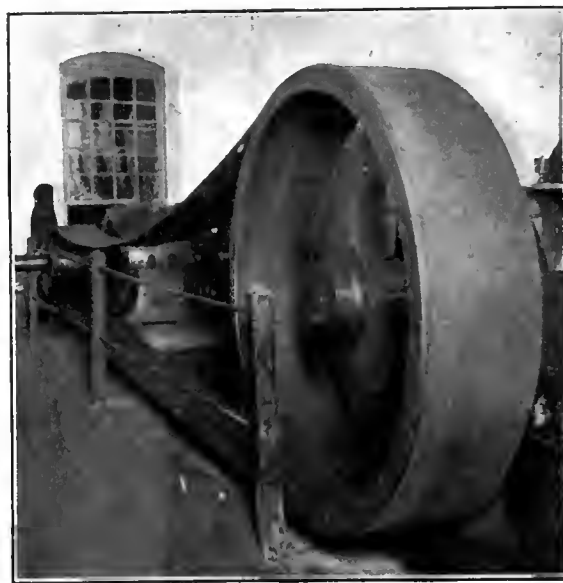

FIG. 1. TYPICAL EXAMPLE OF BELT DRIVE UNDER NON-SLIP TREATMENT.

cause, and where slipping and screeching occur, the belt is invariably to be blamed.

In Prof. Goodman's text "Mechanics Applied to Engineering" it is shown that if properly lined up, a solid shaft

practice, the deflection is not as marked as shown here, but the slightest deflection seriously affects the transmission efficiency as Prof. Goodman indicates. In operation, the shafting maintains that form, and the friction increases with

plied it serves more purposes than one. In occupying all the spaces in the belt, it surrounds every fiber and acts as a preservative lubricant for the fibers when one rubs against the other in bending. An untreated belt wears out more quick-

ly than a treated belt, because in bending the gradual grinding of the fibers hastens internal wear. Besides, selected treatment gives a leather belt the kind of flexibility needed to insure non-slipping—a modern feature clearly shown in the photographs.

Painted Cotton Belts.

When new, painted cotton belts are fairly waterproof owing to the filler that is in them, and the paint on the outside. After being used for a short time, however, this gummy filler on the inside soon dries and cracks. The paint outside also wears or falls off, while fissures appear at the edges, and the fabric becomes filled with minute cracks which alternately gape open and chafe together as the belt goes around the pulleys. It is then an easy matter for water to get in through the openings made, but not so easy for it to evaporate or get out; hence such a belt may rot in a short time. A waterproofing preservative will enter all of these openings, and easily make the belt as waterproof as it was when new, improving and rendering it more serviceable, and making it more waterproof every time an application of the preservative is made.

Unpainted Cotton Belts.

A more troublesome belt is found in the unpainted cotton belt. An unpainted cotton belt is like a clothes line; with every atmospheric change it expands or contracts. However, when these belts are properly treated they are made absolutely waterproof, because there are no glued laps, and because they are already filled with an impervious filler. The preservative readily penetrates between the fibers, mats them together, makes a heavier belt, more dense, with less stretch, with no possibility of cracking and absolutely waterproof. This is a good belt for many purposes and low-priced. The well stitched canvas belt made of piles of canvas is preferable to the woven webbing form of belt, as it stretches less and has more weight and density when waterproofed. A heavier belt is desirable because initial tensions can be readily reduced; if the initial tension is needed it is created by the weight of the belt itself.

Camel Hair Belts.

Camel hair belts when new and through life are much better than ordinary unpainted cotton belts, because they are denser, heavier, and tougher, yet they are similar in behavior to cotton belts either plain or painted, and can be made equally waterproof.

Rubber Belts.

When new, rubber belts are quite able to resist water, but after being used for a short time they develop pin holes through which moisture is admitted, and,

as in the case of the painted cotton belts, the water cannot get out, it rots the canvas. A preservative should be used in this case, also, to fill up these holes.

The photographs given herewith show belts in actual operation in two different plants, pulling loads that tax their full strength, yet they pull their loads with apparent ease. It is evident that a load pulled in this way reduces the shaft deflection to a minimum and thus increases the shaft's efficiency, the total pull being exercised in doing useful work. If the belt elongates, all the better, for the arc of contact is increased, thus maintaining high belt efficiency.

All of these advantages, and, not least, that due to waterproofing, are worthy of earnest study. There is much to be gained in improving boiler, engine, dynamo, and motor efficiencies, but unless belts are properly cared for, that gain is lost in the shafting and never gets to the machinery. Modern belt treatment is largely responsible for the high belt and shaft efficiencies found in the most carefully planned and managed shops of to-day.

We are indebted to the Cling-Surface Co., Buffalo, N.Y., for the illustrations accompanying this article.



THE STATUS OF ENGINEERS.

AT a meeting of the Society of Engineers (Incorporated), held on April 7th, Mr. William Ransom, A.M. Inst. C.E., read his essay on "How to Improve the Status of Engineers and Engineering, with Special Reference to Consulting Engineers," which was awarded the second prize in the Status Prize Competition last year, no first prize having been awarded.

The author pointed out that the civilization of to-day had become possible only because of the efforts of the engineer, but that the public did not sufficiently appreciate the advantages they had gained or the men whose work had secured those advantages. Engineers had many lessons to learn from the legal and medical professions, both of which excluded unqualified men and exercised a benevolent professional control over their members, and the State should recognize the engineering profession by giving it an official standing equal to that of other professions. The State should require engineering aspirants to pass a qualifying examination and should give facilities to pupils and assistants for inspecting large engineering works.

Admission to the profession required to be carefully guarded, and the number of pupils allowed to an engineer should be regulated by the extent of his prac-

tice, while the climax of the period of pupilage should be a State examination. Much more might be done to make examinations of practical value to those who prepared for them, but no other form of test was possible. When State recognition was obtained for engineers, the members of the profession would constitute one great society, amalgamating the existing societies into one body, which should have the control of professional matters and be the mouthpiece of the profession. Such a society would necessarily have sub-sections dealing with special branches of the profession. While the growth of specialization must be recognized, it was essential for those who were beginning their training for the profession to acquire a sound general scientific knowledge before they began to specialize.

The engineer should not be behind his brethren of the legal and medical professions in regard to professional conduct and etiquette, while the society that represents him should maintain a high standard of professional honor, and must have power to enforce its regulations. The State should fix a scale of minimum professional fees. Consulting engineers were comparatively few in number, and on that account the public placed a high value upon their services. They played an important part in forming public opinion on the profession and the ideals they now placed before themselves would make their impress on the younger generation of engineers.

The tone of the profession could not be set by the professional societies, but every individual must live up to a high code of professional conduct. The public estimate of the profession was based not on the conduct of the best members, but on that of the average member, hence the importance of every engineer setting an example of lofty ideals before his staff, his clients and the public.



BRITISH TRADE WITH CANADA.

IT is stated on good authority that, "with a view to preventing the development of Canada falling mainly into American hands, a representative of an influential group of British financiers has just sailed to the Dominion with the object of starting branches of several important British industries in the chief centres. The industries will be financed with British money, and the interests concerned have put up £5,000,000 sterling in order to carry out their enterprise. Several concessions have been obtained by those interested in this scheme, and others have been promised by the Canadian local authorities."

Discussion on Standard Cross-Sections and Symbols

In our February 13 issue, page 133, we published the report of the Committee appointed by the American Society of Mechanical Engineers to consider the question of Standard Cross Sections for Materials. The present article deals with the discussion of that report.

MR. A. A. Adler said that he felt there was no demand for standard cross-sections and saw no advantage in them. To show how cumbersome the system is, it will be observed that nickel, chrome and vanadium steels are marked in addition to their characteristic cross-sectioning. This is due to the limited number of combinations that may be formed by the variety of lines used. A much more serious objection is found in the burden that such a set of standards would impose upon the memory. In order to insure that the workman would use the intended materials, a legend would have to be employed to describe the meaning of the standards. This appears contrary to logical procedure. The present method of specifying the material in a "material list" is by far the most convenient method, as it also includes heat treatment and such other data as are necessary for accurate description. There is, however, one possible use for such standard cross-sections, as for instance, where a change of section indicates a change of material, but in this case no standards of any kind seem necessary.

Mr. J. H. Norris said that in his practice he had used about 12 different compositions of what is listed in the report, fig. 1, as "copper, brass or composition." He had for years sectionalized simply

with a plain line, then marking the materials, although this latter was not usually done, being indicated on the "material list" accompanying the drawings. Thus, if the material is changed, the drawing does not have to be corrected, but simply the list. The list of standards proposed seemed to him to be unnecessary.

Mr. A. E. Norton thought that Professor Adler had misinterpreted fig. 2 in respect to the use of printed labels to indicate chrome steel, nickel steel and other variations of chemical composition. Such labeling is entirely optional, the hatching lines being used only to indicate the process of manufacture, that is, whether the steel is a casting or a forging.

F. De R. Furman, speaking as a member of the committee, said that the putting out of these specifications for the representation of different materials had been induced by the fact that a number of different standards are in use in different drafting rooms. It seemed a desirable thing to secure co-operation between the drafting rooms, which already used a special kind of cross-section line, and have them adopt a uniform standard, to avoid confusion.

Mr. Spencer Miller regarded the plan as valuable since it allows of the adop-

tion of as many or as few of these standards as may be desired in any drawing room. If any plan is to be adopted at all by a drafting room, it would seem better to adopt one which others have agreed to.

Messrs. L. P. Alford and Arthur L. Ormay, the authors of this discussion are firm believers in the principle of engineering standardization and its application to engineering work. Thus, when the report of the Committee on Standard-Cross Sections and Symbols was published, they at once turned to it with the purpose of adopting the standards there recommended in their own work. Careful study, however, led to the conclusion that it was impractical to make use of the material thus presented, for a number of reasons, and further consideration led to the preparation of this discussion.

The most serious objection is incompleteness. There are no symbols for a large number of the materials frequently used in mechanical engineering and represented on drawings of members of the society. Other objections are, a failure to use lines of uniform direction, the sacrifice of individuality in the symbols to a uniform weight of line, and finally, an apparent failure to consider the practice and standardization work of others. Further, the general

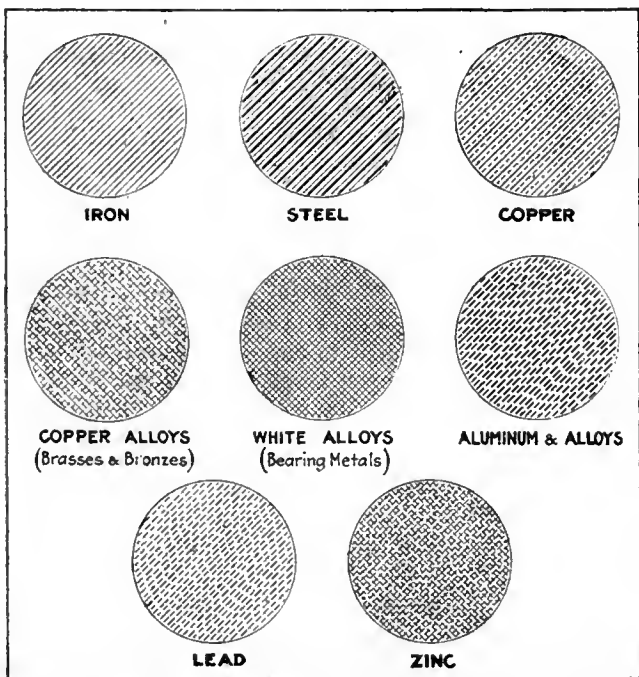

FIG. 3. CROSS-SECTIONS FOR METALS.

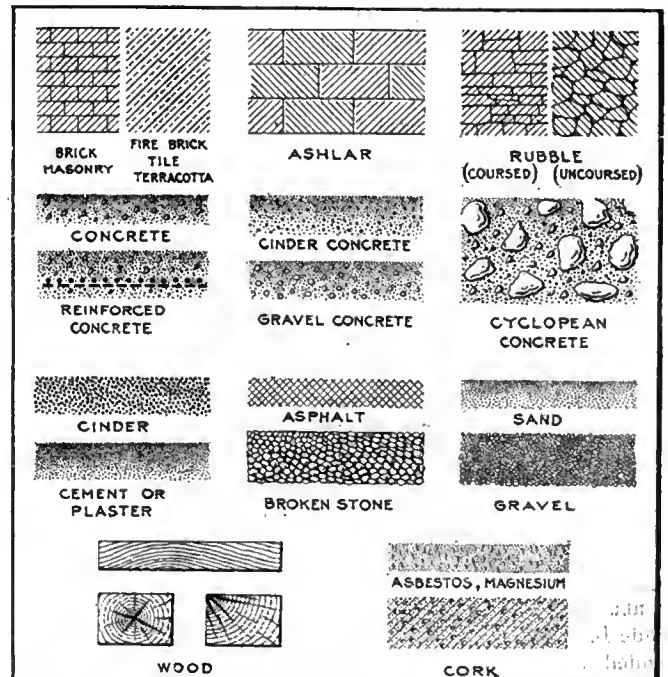

FIG. 4. SYMBOLS FOR BUILDING MATERIALS.

scheme of classification is open to a difference of opinion, for another viewpoint has been taken in the cross-sections and symbols accompanying the discussion.

Symbols Suggested.

The meaning of these objections can best be seen by turning to the symbols shown in figs. 3-6, which are offered by groups: Cross-sections for metals, fig. 3; symbols for building materials, fig. 4; symbols for geologic formations, fig. 5; and symbols for miscellaneous materials, fig. 6. In all of these cross-sections and symbols having ruled lines, the direction of the lines is standardized to

or used in engineering work; that is, the metal cross-sections are presented by a circular cross-hatched area which might represent the end of a bar, or rod. Earth and rock are shown by an irregular outline that might be part of a section of a bank or ledge. This same idea has been carried out in connection with some of the others.

The general scheme followed in developing this series has been to distinguish between families of materials by

It is believed that these cross-sections cover all the important families and ordinary engineering metals that are used unalloyed. In practice, the symbol for iron would ordinarily be applied to cast iron, and if any of the other kinds were to be specified its abbreviation or name would be printed across the section. Similarly, the steel cross-section would be taken to mean a low-carbon machinery steel, and the other grades indicated by abbreviations or names.

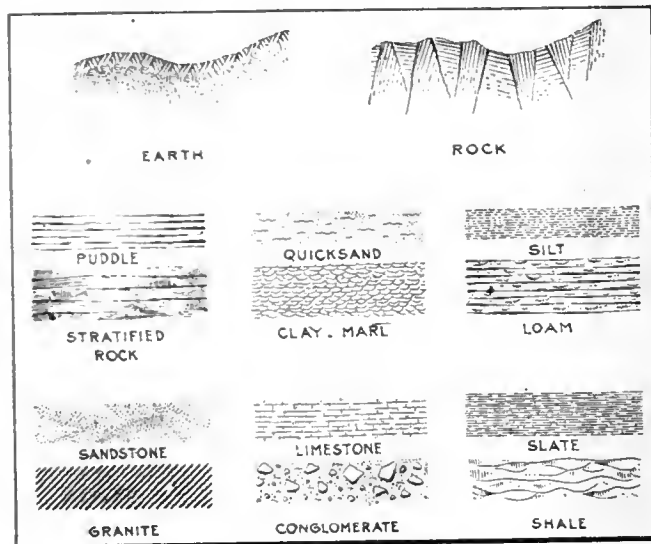

FIG. 5. SYMBOLS FOR GEOLOGICAL FORMATIONS.

two—horizontal and inclined at an angle of 45 deg. with the horizontal. In addition to these, the Committee's Report includes inclined lines, at an angle of 30 deg. with the horizontal, as seen in the symbol for babbit or white metal.

Four weights of line are used. The Committee's Report standardized this feature to a single one. This is a simplification of practice at the expense of result. To the authors' minds such a course is unjustifiable, and the quality of the results can be judged by referring to the cross-sections for wrought iron, cast steel and wrought steel in the Committee's Report. From the casual glance of a person familiar with reading drawings, there is but little difference between these cross-sections, not enough to individualize any one of them. In fact, they are so similar that it is doubtful if draftsmen would readily remember them and their differences.

As a detail in the method of presenting these suggested cross-sections and symbols, a difference in form has been made for different materials. This is intended to have some reference to the shape in which the material is met with

cross-sections and symbols easily remembered, and then make use of abbreviations or names to distinguish sub-divisions of these groups. This group system is best illustrated by the cross-sections for metals and the symbols for concrete.

Cross Sections for Metals.

The metals group has eight cross-sections, fig. 3; of these, five are family groups. The iron group includes cast iron, malleable iron, wrought iron, ingot iron and perhaps others. The steel group includes tool and cast steel, high-speed steel, crucible and high-carbon steel; alloy steels, as nickel, manganese, chrome nickel, vanadium, and the ordinary steels of machinery construction, such as Bessemer cold rolled, open hearth, machinery, cold drawn and low carbon. The copper alloys include brasses and bronzes in all their variety; white alloys include babbit and all kinds of white metals; and the aluminum group aluminum and its alloys. The other three symbols are for copper, lead and zinc, respectively. It should be noted that the copper alloy cross-section is a combination of the copper and lead rulings.

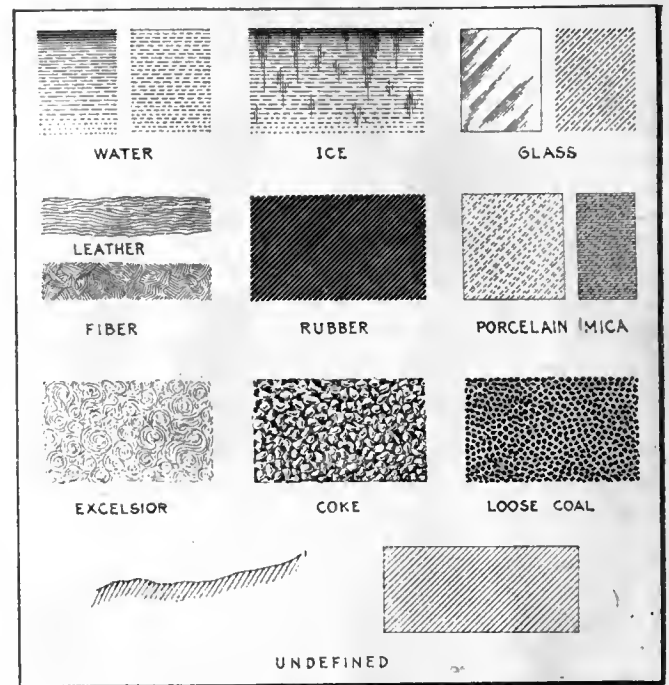

FIG. 6. SYMBOLS FOR MISCELLANEOUS MATERIALS.

This same method could be applied to the copper alloys.

Symbols for Building Materials.

Little comment need be given to the 19 symbols for building materials, fig. 4, except that those presented are believed to cover the ordinary materials met with in the work of members of this Society. Attention is called to the symbol for ashlar, which is believed to represent this important material better than the one shown in the Committee's Report.

Symbols for Geologic Formation.

Here are 14 symbols, fig. 5, which are believed to cover the formations ordinarily met by members of this Society in connection with foundations for buildings, dams, and other engineering structures. In general, they follow the symbols prepared and published by the United States Geological Survey, and thus have the advantage of being already in use.

Symbols for Miscellaneous Materials.

The symbols for miscellaneous materials, fig. 6, are 11 in number. Some of these may seem new, but all have found

use in the work of the authors. The reason for most of them is apparent. By way of explanation, excelsior, coke and coal are represented on power plant drawings, in cross-sections of boilers, coal pockets, gas producers and gas scrubbers, as the case may be. The final symbol on this chart is for undefined or unclassified material, and follows the suggestion contained in the Committee's Report.

In conclusion, the authors have written this discussion with a single motive, that of aiding in the constructive work of preparing a series of cross-sections and symbols adequate to the entire field of the work of the mechanical engineer and arranged in a form to be adopted and used. It is hoped that the Report which has been discussed will be considered merely as preliminary and that further consideration will be given to this important subject.

In connection with further work, two suggestions are in order. The first is the preparation of a series of abbreviations of the names of the materials forming the sub-divisions of the general groups. The second is much broader and is that of making a complete study of drawing-room conventions. The modern conception of mechanical drawing is that it is an engineering language. Though this characterization is true, it is a language without uniformity, without grammar, and filled with dialect and peculiarities of expression. A careful investigation of mechanical drawing conventions, with a report putting them in comprehensive form, would be of great value to the members of the Society and to our engineering colleges.

Mr. O. K. Harlan wrote that for the cross-sectioning for wrought iron he would prefer a light and heavy line in pairs, similar to that for cast steel, but having one of the two light lines made heavier. This has been used for many years and he believed to be now in quite general use. It gives a clearer distinction between wrought iron and steel than the sections shown in the Report, and can be made with the same number of strokes of the pen by retracing one of the two light lines and making it twice as heavy. The sections shown in the Report require a second glance to tell which is which, wrought iron or steel, since they are so nearly alike.

The sectioning for rubber did not seem to him to be the best obtainable. Insulation as used in electrical work often involves small pieces, and to use the sectioning shown would admit of confusion between the section lines and the actual lines of the mechanism. In some cases he had used solid black, as rivet holes are sometimes shown in structural steel work, and he had also used soft black pencil on the tracing, which gives an

effect on the print which is easily distinguishable. By lettering hard rubber, fiber, vulcanite, etc., in ink on the tracing, it shows clearly on the print and seems to cause less confusion than the light horizontal lines recommended by the committee. He was not disposed, however, to urge the use as standard of either the black pencil or solid black ink.

The Authors.

Referring to the suggestion of using lines of more than one thickness, the Committee have reached the conclusion, after careful consideration, that lines of uniform thickness will not only facilitate the drawing of cross-sections, but will save much time in waiting for heavy ink lines to dry. If draftsmen had always been in the habit of using lines of uniform thickness in cross-section work, the committee doubt very much if they would now adopt sections made of lines having variable weights.

The underlying principle of the standard sections recommended is the use of single lines for cast iron, then the wrought and forged irons are indicated by making every alternate line double. In a similar way, cast steel is shown by double lines in pairs and all the wrought and forged steels by adding an additional line to each alternate pair. The Committee have avoided the use of dotted lines in all cross-section work, except when such lines are used in combination with solid lines, thus preventing confusion with dotted lines which represent objects behind the plane of section.

It is true that frequently rubber and insulation materials are shown in solid black. When these sections are narrow there is no objection to this practice, when the sections are wide, heavy patches of ink tend to crumple the tracing cloth or paper, and in such cases the section recommended by the Committee would be clearer and not liable to confusion. In cross-sections showing babbit or white metal, which usually occur in narrow widths, the committee recommend the use of a 30-60 deg. line, because it facilitates the act of drawing by requiring a fewer number of lines.

The Committee believe it would not be wise to attempt to formulate a standard for every material. Symbols for various building materials, and symbols for geologic formations and symbols for miscellaneous materials, the Committee believe, are best worked out by subdividing one of the standard cross-sections as recommended, according to the scheme reported on by the Committee under typical sub-divisions. Such sub-divisions are chiefly used by specific trades or by those working along particular lines. The committee see no objection to the use of many of the sym-

bols submitted by M. L. P. Alford and Mr. Arthur L. Ormay, but believe that they should be classified under typical sub-divisions, rather than included as standard cross-sections or symbols.

GRAIN ELEVATORS.

ELEVATORS as a means of housing and handling grain did not make their appearance until the latter part of the last century. According to Concrete and Constructional Engineering, the first real elevator of which there is any record was the "cribbed" wood type, and there are still a good many of these houses in existence. This old type is interesting when it is considered that at one time an elevator of nearly four million bushels capacity was erected complete, and almost totally filled with grain, in a period of forty-four days. Of course, lumber was plentiful, and no expense was spared and no restrictions put on the builder except to gain time. The first fire-resisting elevators were built of steel, practically on the same plan as the old wooden structures, which were rectangular in plan and had cribbed bins elevated on posts and usually arranged to suit unloading conditions.

Up to this point, all storage and handling devices were carried under one roof, but it was then demonstrated that all machinery for unloading, handling, and shipping could be more economically installed in separate buildings called the working house. This was accomplished by having two or more parallel tracks alongside the house for unloading, thus shortening the house and necessarily making it more economical; a separate building for storage having larger compartments than in the working house being erected. At about this time, brick, tile and concrete came into common use in the construction of elevators.

DREDGE DIPPER TRIPS.

THE dipper dredges Minda and Chagres operating in the Atlantic entrance channel to the Panama Canal and on coral rock excavation for the new piers of the Panama Railroad Co. at Cristobal, have been equipped with steam dipper trips which a test of six months has shown to be successful. The trips were installed by the dredge crews under the direction of one of the cranesmen, Mr. Henry Cartier, who selected the most of the material from scrapped French machinery.

The dredges, mounting 5-yard dippers, are used entirely in rock, which when necessary, has been partly broken up by the operations of the drillboat Terrier.

They are cutting channels of a minimum depth of 42 feet at mean tide. This requires dipper handles of great length. **Cartier's Steam Trip for Dipper Lip.**

The procedure requires a quick-acting trip, to avoid spilling over the edge

and simple in construction, due to the arrangement of boom and dipper stick, and be so arranged that the tripping line would not have to be overhauled on a drum or otherwise. As will be seen by the accompanying sketch, the Cartier device consists of a steam ram (C), mounted on a foundation in an out-of-the-way position on the interior of the

on the supporting guide arms for the equalizing sheave. The cylinder valve is of simple design and operated through the operating lever (A) and the reach rod (B). The latch chain is led to the purchase lever (G), which is made fast to the dipper handle in the manner shown, and a $\frac{1}{2}$ -inch flexible steel cable (F) is made fast to the opposite end and led back over the small idler to keep the slack end of the line from becoming entangled. It is then led over one of the two idler sheaves (E) mounted on a stationary shaft parallel to each other, thence over the sheave (D) back over the other idler sheave (E), and up and dead-

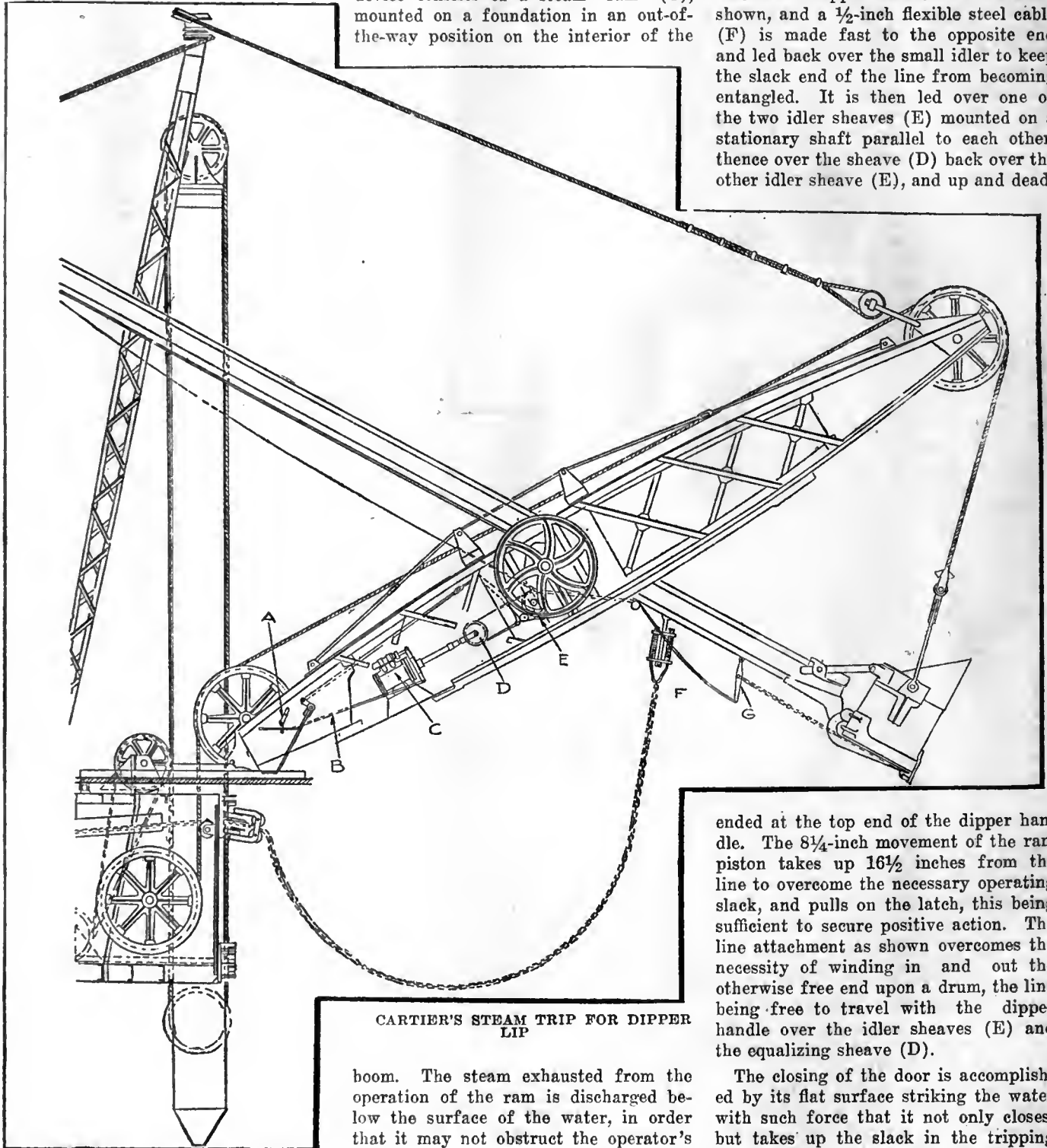

CARTIER'S STEAM TRIP FOR DIPPER LIP

boom. The steam exhausted from the operation of the ram is discharged below the surface of the water, in order that it may not obstruct the operator's view.

The cylinder is 5-inch bore and has a stroke of $8\frac{1}{4}$ inches. The piston rod carries the equalizing sheave (D), and the jamb movement of the ram piston is decreased by allowing the shock to be taken up in two heavy $\frac{1}{2}$ -inch by $\frac{1}{2}$ -inch springs, $3\frac{1}{2}$ inches long, mounted

ended at the top end of the dipper handle. The $8\frac{1}{4}$ -inch movement of the ram piston takes up $16\frac{1}{2}$ inches from the line to overcome the necessary operating slack, and pulls on the latch, this being sufficient to secure positive action. The line attachment as shown overcomes the necessity of winding in and out the otherwise free end upon a drum, the line being free to travel with the dipper handle over the idler sheaves (E) and the equalizing sheave (D).

The closing of the door is accomplished by its flat surface striking the water with such force that it not only closes, but takes up the slack in the tripping line (F) and pulls the piston into a starting position in the ram. The saving in time and the increase in yardage through use of this device cannot be arrived at, as no efficiency tests have been made, but it is known that a considerable increase in the yardage has been achieved.

of the barge on the return swing. Operation by hand was slow and uncertain, because of the weight and accumulated slack in so long a trip line, besides, requiring the use of both hands by the craneman. It was necessary that the tripping device be both positive in action

HIGH SPEED TRANSMISSION DYNAMOMETER.

By James A. Adie.*

IT is often of great importance to ascertain the amount of energy produced by some form of prime mover, or absorbed in the operation of any apparatus. Various kinds of dynamometers have been devised for this purpose, the best known being the Prony brake. This brake, while possessing all the advantages of cheapness and accuracy, is only suited to the measurement of small powers, due to the heating and burning of the blocks, to the difficulty of lubrication, and to the liability of the wood to seize on the pulley. It can, moreover, only be used to measure the output of prime movers, while it is often necessary to discover the input of a driven machine.

Torsion Dynamometer.

Another form which has come into extensive use is the torsion dynamometer, used to ascertain the power of turbines on the great Atlantic liners. For this purpose a long sleeve is placed on the tail shaft, attached to it at one end only. At the other end is a multiplying device, whereby the motion of the shaft relative to the sleeve is shown in exaggerated form on a card. The horsepower is computed from the torsion of the shaft in the length of the sleeve, in accordance with tests previously made on test shafts of similar material. This dynamometer, while simple and accurate, only gives the maximum horsepower developed during the trial.

Obtaining Instantaneous Readings.

It is often desirable to know the power at a given instant, so that it may be compared with the instantaneous readings of other instruments, as in the case of tests on motors and generators, centrifugal pumps, blowers, or other high-speed rotary machinery. For instance, in the test of a generator it may be desired to know the energy taken to drive it under various loads and speeds, so that by comparing these readings with those taken from the switch board instruments a curve of efficiency may be drawn.

For this purpose a transmission dynamometer of the form shown in the sketch has been used, by which the horse-power at any particular moment may be ascertained. It consists of a shaft about 6 feet long, to which an ordinary flanged coupling is keyed at each end. One of these couplings is bolted to the coupling on the driven machine, and the other to that on the prime mover or other source of power.

The disc (A) is of cast iron, and is

pinned through the hub to the shaft by a light pin, in order not to impair the stiffness of the shaft. Near the circumference a slot is cut through the disc and covered by two thin steel plates, so fastened by machine screws that the aperture may be regulated as desired. Usually the slit is set from 1-16in. to 1/8in. wide. To the hub on the back of this disc is attached a tube of wrought iron pipe about 4 feet long. This tube is pinned at the other end to the hub of disc (B), which is of the same diameter as (A). In disc (B) is cut a slot about 4 inches long at the same distance from the centre as that in disc (A). Disc (B) is bored to a running fit on the shaft. A small brass

How the Dynamometer is Calibrated.

This appliance must be calibrated before using. For this purpose it is set up and a lever is bolted to one coupling and counter-weighted, so as to cause no turning moment by its own weight. Weights are applied at the end of the arm sufficient to rotate disc (B) relative to disc (C), causing the brass pointer to move to new positions opposite the divisions on the scale (D). The loads corresponding to the various divisions are then noted.

In one test a shaft 1 1-16-inch in diameter 48 inches long twisted through an angle of 9 degrees with a load of 186 lbs. at 30 inches radius. This cor-

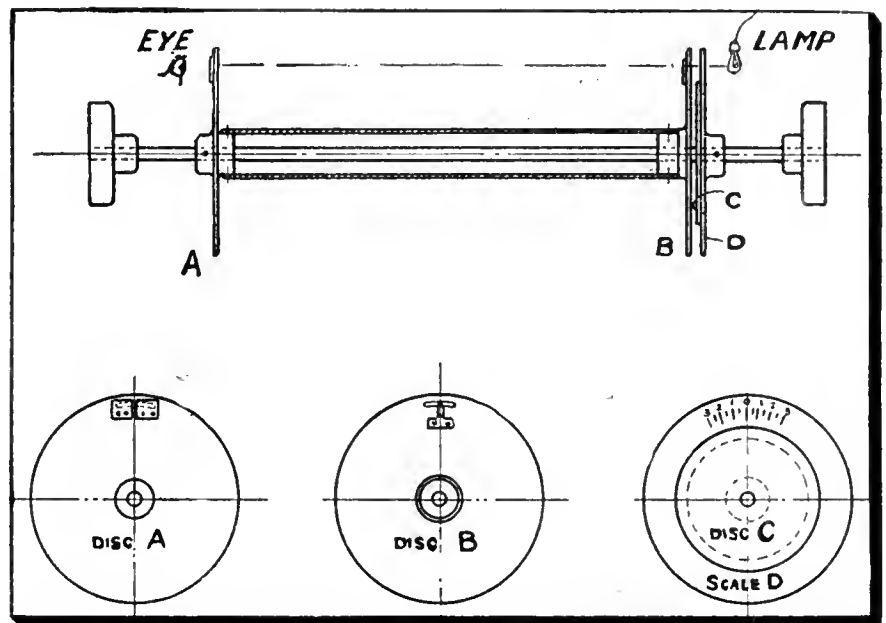

HIGH SPEED TRANSMISSION DYNAMOMETER.

pointer is fastened over the slot by screws, so as to be adjustable sideways for purposes of calibration.

Behind (B) a smaller disc (C) is pinned to the shaft, and attached to its periphery is an annular piece of transparent celluloid, marked off in equal divisions, about 3/8in. apart, each with a corresponding number, as shown. These numbers and marks are stamped in and blackened to render them clearly visible.

The pointer on (B) is set opposite the zero mark on the scale behind it, and the slit in (A) is placed in line with both. Now it is evident that if one coupling be held fast and a turning force be applied to the other, the disc (B) will follow the motion of disc (A), while disc (C) will remain stationary, and the motion of disc (B) relative to (C) will be through the same angle as the torsion of the shaft between (A) and (C).

responds very closely to the result of the formula:

$$a = \frac{Pr \times 583.6}{d^3 E}$$

- where a=angle of torsion in degrees.
- P=force in lbs. applied at end of lever arm.
- r=length of arm in inches.
- l=length of shaft in inches.
- d=diameter of shaft in inches.
- E=co-efficient of elasticity (about 12,000,000 for steel).

Application of the Dynamometer.

In operation the dynamometer is placed in the line between driver and driven so that it transmits the full power to be measured. The torsion causes the pointer on (B) to move from opposite the zero mark on the disc (D) to a new figure, depending on the power. A lamp is held behind the scale on (D) and on applying the eye opposite the

*With the Canadian Boving Co., Limited, Toronto.

slit in (A) and sighting past the pointer, the number indicated on (D) may be read as if it were standing still; for the slit (A) flashes past the eye so rapidly and the intervals between the impressions on the retina are so short that it causes the illusion of a stationary figure.

This dynamometer cannot be used successfully below 600 R.P.M., as a lower speed would not produce a clear image on the eye. It may be used for rotation in either direction.

The figure opposite the pointer having been read, it is known from the previous experiments that this represents a certain force in pounds at the end of the lever used in the experimental test. The speed may be ascertained by a revolution counter or the more modern direct reading tachometer of Dr. Horn's type.

This force exerted through the circumference of the circle described by the lever arm and multiplied by the number of R.P.M. gives the power in foot-lbs. per minute, which, divided by 33,000, is the horse-power transmitted. In other words:

$$HP = \frac{Pr \times 2 \times 3.1416 \times N}{33,000} = \frac{Pr \times N}{5,200}$$

where P=force in lbs. at end of lever arm.

r=length of lever in inches.
N=R.P.M.

In designing such a dynamometer care must be taken to select a size of shaft in which the stress will not exceed the elastic limit of the material. At the same time the angle of torsion should be as large as possible in order to give a good range on the scale. The elastic limit for steel, according to the manufacturers' specifications, should be not less than half the ultimate strength, and may be taken at 40,000 lbs. per square inch.

Examples Worked Out.

Supposing that a generator of 100 k.w., running at 1,500 R.P.M., is to be tested:—100 k.w. is equal to about 134 h.p., and the twisting moment (Pr) on the shaft is:

$$PR = \frac{63025 \times HP}{N} = \frac{63025 \times 134}{1500} = 5630 \text{ inch lbs.}$$

By the commonly accepted formula for shafting

$$d = \text{cube root of } \frac{16PR}{3.1416 \times S}$$

where Pr=twisting moment on shaft in inch lbs.

S=permissible fibre stress on shaft in lbs. per sq. inch.

d=diameter of shaft in inches.

It would not do to stress the shaft right up to its elastic limit, so we will allow a factor of safety of 2, which will give 20,000 lbs. as the value of S in the above formula.

In the example under consideration

$$d = \text{cube root of } \frac{16 \times 5630}{3.1416 \times 20000} = 1\frac{1}{8} \text{ inch}$$

Since the fibre stress has been kept low a dynamometer having a shaft of this size could be used for testing generators of larger size than the example given; but care must be taken that the elastic limit is never exceeded. The diameter of the discs should be such that the rim speed will not exceed 8,000 feet per minute.

The angle of torsion of such a shaft, 48 inches long, between discs (A) and (C) may be found from the formula given above, viz.:

$$\text{angle} = \frac{Pr \times l \times E}{12 \times d^4 \times S} = \frac{5630 \times 48 \times 583.6}{12 \times (1\frac{1}{8})^4 \times 12,000,000} = \text{ab. } 8 \text{ degs.}$$

WORLD'S OUTPUT OF ELECTRIC STEEL.

ACCORDING to the Comité des Forges de France, the world's output of electric steel was about 47,000 tons in 1909, 120,000 in 1910, and 126,000 tons in 1911. These figures are made up from returns from Germany, Austria, the United States, France, and Sweden, England is not included, although a small quantity of electric steel is produced, there being eight or ten electric furnaces at work there. Germany is the largest producer of electrically smelted or refined steel, her output for 1911 being 59,000 tons. Sweden although frequently mentioned for its work in this line, produced a bare 2,000 tons in preceding years.

According to the tables, the United States produced 51,000 tons in 1910, but only 28,500 tons in 1911. This drop is surprising, especially as the number of electric furnaces increased from seven in 1910 to nine in 1911. Austria and France, the latter with 13,500 tons and the former with 22,400 tons, also made very little progress in 1911, but no doubt when the figures for 1912 are available they will show large advances all round.

It appears probable that the world's output for 1912 was not far short of 200,000 tons. This is only a very small proportion of the world's total steel production, but, says the "Manchester Guardian," it is sufficient to prove that for some conditions the electric furnace is a live commercial instrument.

TEST OF AN AMERICAN DIESEL ENGINE.

SOME tests were recently carried out by Professor A. C. Scott on a 225-brake-horse-power Diesel engine at the Hugo (Okla) Ice and Light Co.'s works. The engine was built by the Busch-Sulzer Brothers Diesel Engine Co., of St. Louis, U.S.A. Six test runs were made, each at a different load, and as the engine was from time to time required to carry its plant load, the six tests had to be spread over a period of

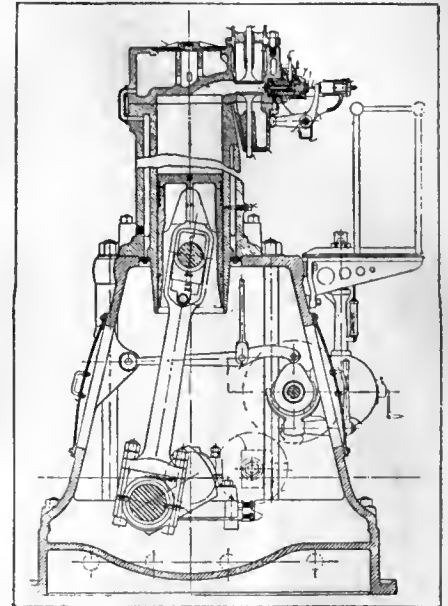

AN AMERICAN DIESEL ENGINE.

several days. The engine had been in service for about six months, and prior to the tests, no special tuning-up was attempted. The fuel used gave 18,986 B.T.U. per pound. The engine was coupled to a three-phase generator, and the load was adjusted by means of a water rheostat. The air compressor was driven from an outside source, but the power used by it has been allowed for in the test figures.

The consumptions of fuel oil were as follows:—10.8 gallons per 100 brake-horse-power hours at quarter load; 6.8 gallons at half load; and 6.2 gallons at full load. This latter figure corresponds to 0.441 lbs. of oil per brake-horse-power hour. The thermal efficiencies were 17.4 per cent. at quarter load, 27.8 per cent. at half load, 29.5 per cent. at three-quarter load, 30.3 per cent. at full load, and 20.2 per cent. at 10 per cent. overload. The Busch-Sulzer Brothers Diesel Engine Co., who built the engine, are erecting a large plant at St. Louis to be devoted wholly to building Diesel engines. The plant will be put into operation about the beginning of June.

MACHINE SHOP METHODS ^A_N^D DEVICES

Unique Ways of Doing Things in the Machine Shop. Readers' Opinions Concerning Shop Practice. Data for Machinists. Contributions paid for.

A CHEAP JIG.

By D. O. Barrett.

THIS method of quickly and cheaply producing a jig is, of course, not meant for manufacturing purposes, but for shop work, such as core boxes, dryers or other pieces in which there are a number of holes to be drilled, and in which interchangeability must be secured. In a shop of any size, it is well to have a number of standard bushings—the definition, "standard" having reference to holes of the proper size for dowel pins most generally used. Where it is necessary to drill two sizes of holes at the same location, slip bushings may be used.

Assume for instance, that some core boxes have to be drilled for dowel pins; that one of them has been laid out and drilled accordingly, and that the pins have been inserted in the holes and the bushings slipped over them. The core box should then be bedded in sand, and babbitt, lead or other soft metal poured both in the box and around the bushings. If the box be large, it need not be entirely filled with babbitt, but only at each end or at the two most important points; and should it be long, a steel piece may be laid in, and the babbitt poured around it at each end to fasten both rigidly together. Should the bushings draw-in on the pins, they may be loosened by peening the babbitt in the

centre, after which, the babbitt is scraped slightly for clearance, and the jig is ready for use. The foregoing procedure furnishes a ready means of producing interchangeability among a few pieces at a small cost, and will be found extremely useful many times around a shop of any size.



CHUCK FOR SMALL MILLING CUTTERS WITH SHANK.

By L. E. Gehman.

THE illustrations with dimensions show a chuck for small milling cutters with shank, and is used mostly for hand milling and profiling. The body (A) is made of machine steel, pack-hardened, and the shank in this case was made to fit a milling machine with a spindle bored for a No. 7, Brown and Sharpe taper. The grip bushing or jaws shown at (B) is made of tool steel spring tempered, and has three slots cut in each end which allow it to grip along the entire length of the bushing. One end of the bushing is tapered 15 degrees to the side and fits into the shank or body at (D); the other end being turned to an angle of 30 degrees to fit the nut (C). The nut (C) is made of machine steel, case-hardened and milled hexagon, so that a wrench can be used in tightening it to the body (A). Both (A) and (C) have 20 threads per inch.

In tightening nut (C) on the body (A) the 30-degree taper on the former is forced against a taper on an equal angle

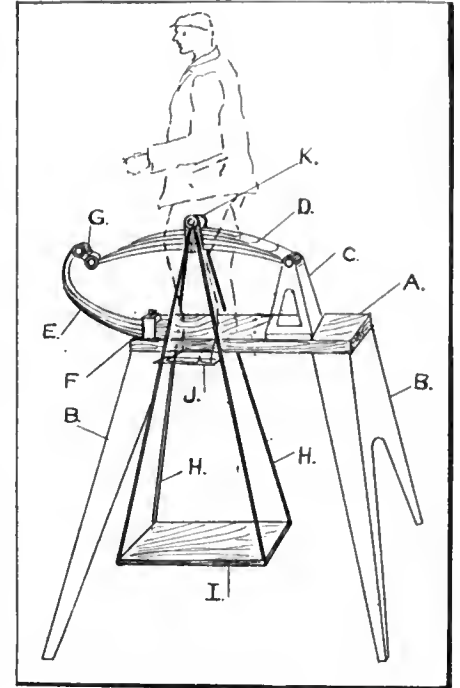

SPRING TESTING MACHINE.

of grip-bushing or jaw (C). This forces the grip bushing back against the 15-degree taper on the body, thereby compressing the bushing as shown in the assembly (E).

Chucks as described above have been in constant use in a typewriter factory for nearly two years and have proven in every way successful.



SPRING TESTING MACHINE.

By H. R.

THE rapid strides that have been made in the construction of automobiles is due to manufacturing concerns always experimenting, and the machine of to-day is the outcome of years of experimental failure and success. The sketch illustrates a means adopted for testing the resiliency of rear springs. This apparatus consists of a plank of wood (A) to which are fastened the legs (B) and onto this table structure are fixed the two brackets (C), between which one end of the spring (D) is held. The spring (E) is bolted to the table at (F), and springs (D) and (E) are fastened together by the shackle (G). It

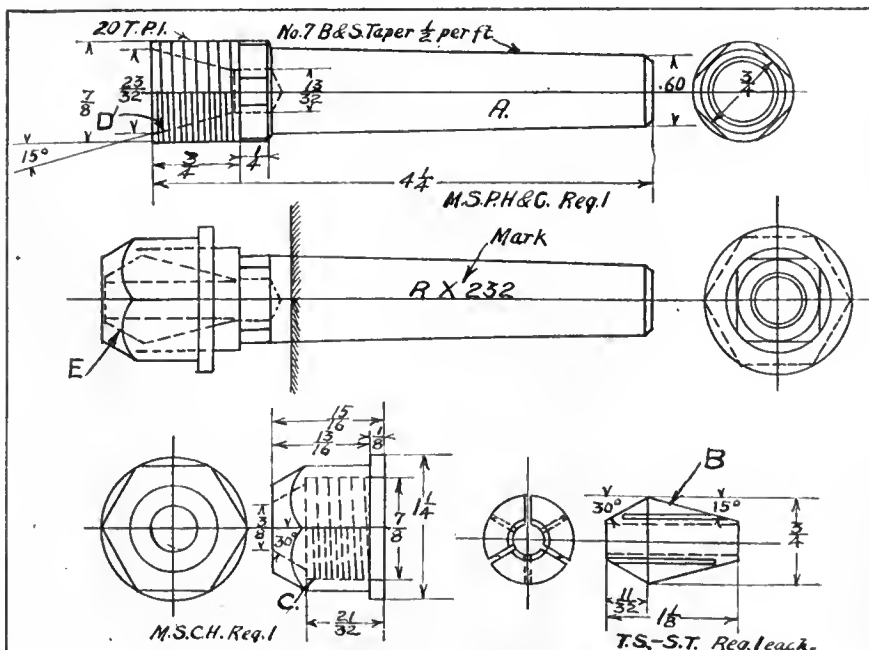

CHUCK FOR SMALL MILLING CUTTERS WITH SHANK.

will be readily seen that this forms one side of the rear suspension of a car. The specially constructed cradle which consists of four wrought iron bars (H), on to which is fitted the base (I) and the two platforms (J), and which swings by the fulcrum (K), is now put in similar relation to the centre of the spring (D) as that of the axle of the car.

To operate:—A weight corresponding to that which will eventually be on the one particular set of springs, is put into the cradle on the base. The operator then mounts the platforms (J) with his watch in hand, moves up and down on the springs. By this method, he is able to count how many times he can vibrate the springs up and down per minute. Each pair of springs, as a result, are assured of being of the same strength, and therefore, of the same resiliency.



BUOYS FOR THE PANAMA CANAL CHANNEL.

THE sides of the Panama Canal channel will be marked by gas buoys each consisting of a cylindrical floating steel body surmounted by a steel frame which supports a light and lens at a height of 15 feet above water level. The body is eight feet in diameter, made of 5-16 inch steel plate with dished heads, to the bottom of which is attached a steel tube and counterweight. The draught of the buoy will be twelve feet, and it will be moored on its station by a heavy chain and a concrete sinker.

The corroding action of the salt water and sea air in the tropics is such that extra precautions must be taken to protect the buoys, and, therefore, the entire inside of the buoy is given first a coat of bitumastic solution, applied cold, and second, one coat of enamel applied hot. The exteriors of the buoys which will be moored in salt water will be given one coat of boiled linseed oil applied hot and two successive coats of the best quality of red lead, after which they will be treated with an antifouling compound.

The entire bed of what will be Gatun Lake, when the water is allowed to rise to an elevation of 87 feet, is covered with a dense tropical growth which in the state of decomposition causes the water to scour all ordinary paints from any kind of metal. To overcome this chemical action, the exterior of the buoys will first be painted with red lead and linseed oil, after which they will be painted with anti-corrosive paint.

The lens and lantern at the top of the steel superstructure contains the source of light which in all buoys is a small acetylene flame of about 40 candle power. The rays of light of this flame when projected through the lens produce a light of about 450 candle power. The acety-

lene gas for each buoy is stored under about 150 lbs. pressure in four tanks technically known as accumulators; each accumulator being inserted in a pocket in the body of the buoy, from which it may be withdrawn when empty and replaced by a fully charged accumulator

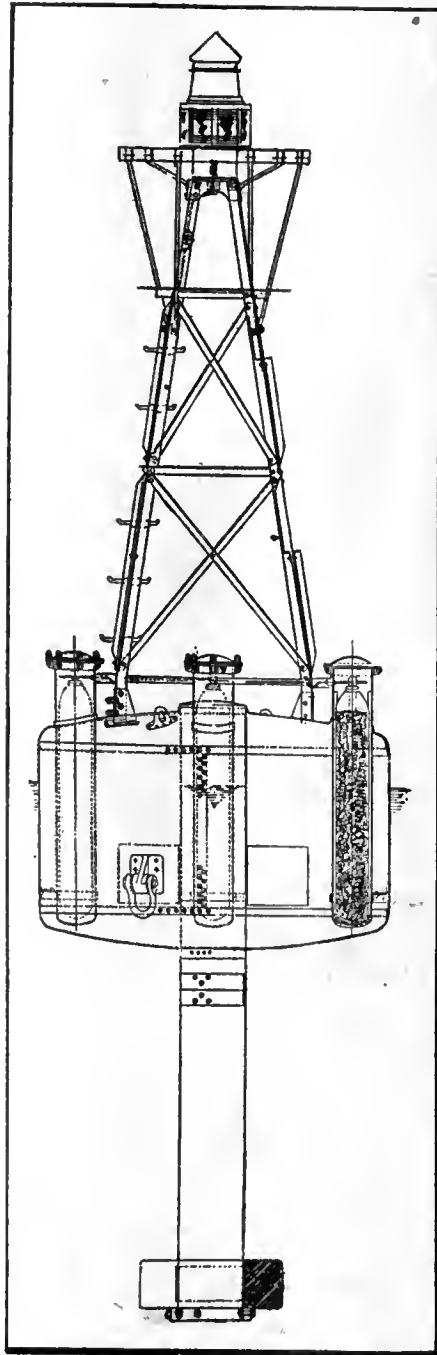

BUOYS FOR THE PANAMA CANAL. FOCAL PLANE 15 FEET ABOVE WATER LEVEL. EIGHT OF THESE BUOYS WILL BE PLACED IN THE ATLANTIC ENTRANCE, 6 IN THE PACIFIC ENTRANCE, AND 43 IN EASTERN LAKE.

without taking the buoy out of the water. The gas of the four accumulators is led through piping to a manifold, thence up one leg of the steel superstructure to a governor in the base of the lantern. This governor reduces the high pressure to the uniformly low pressure required at the burner.

Each accumulator is a steel cylinder nine inches diameter and 69 inches long, tested to 75 atmospheres and completely filled with a porous mass possessing a porosity of 80 per cent. Half of the porous space is occupied by acetone which is a peculiarly excellent solvent for acetylene. Acetylene dissolves as freely in it as sugar does in water, and the solubility increases with the pressure applied. Acetone dissolves 25 times its own bulk of the gas at ordinary temperature and for each additional atmosphere of pressure to which it is subjected a similar quantity will be dissolved. Compressing acetylene to more than two atmospheres at a temperature of 71 degrees F. makes it liable to explosion, but when the gas is forced into acetone, a mixture is secured which is free from danger of explosion, and therefore available for safe transportation and handling.

All the gas buoys will have flashing occulting lights, similar to those of the beacons for the Culebra Cut, and to obtain the flashes and occultations, the gas issuing from the governor at the base of the lantern passes into a small device known as the flasher through a valve which remains open during the whole dark interval. When a certain predetermined quantity of gas has passed into the flasher, so that a flexible leather diaphragm is at the top of its stroke, the inlet valve instantaneously closes, and simultaneously the outlet valve of the main burner opens, allowing the accumulated gas to pass to the main burner where it is ignited by a constantly burning pilot flame. The gas outlet remains open until the total gas quantity has been consumed in the main burner, whereupon the outlet closes and the inlet opens, remaining open until a similar quantity of gas accumulates in the flasher, when the cycle of operations is again repeated. Thus the light and dark intervals alternate automatically, and produce a flashing or occulting light.

The gas supply in each of the buoys will last from three to seven months depending upon the characteristic of the light, and will burn continuously day and night during that time. The acetylene gas will be made at the oxy-acetylene gas house at the Balboa Shops where it will be compressed and forced into the portable accumulators.



STEEL FOR POLSON DRY DOCK

THE steel for a floating dry dock to be built at the Polson shipyards has arrived, and it is expected that a start on the work will be made shortly. When the dock is completed it will accommodate the largest passenger or freight steamer on the lower lakes.

DEVELOPMENTS IN MACHINERY

A Record of New and Improved Machinery Tending Towards Higher Quality and Economical Production in the Machine Shop, Blacksmith Shop or Planing Mill.

DOUBLE CRANK, DOUBLE ACTION TOGGLE DRAWING PRESS.

THE illustration given herewith of the "Toledo" No. 268 $\frac{1}{4}$ Double Crank, Double Action Toggle Drawing Press shows a number of new and novel features for operating toggle drawing presses. The rocker shafts run through the solid arch of the press front to back, being therefore, much more rigidly supported and much shorter between the toggle joint supports or bearings, and eliminating to the greatest possible extent the torsional strain, especially on the wider patterns of double crank machines.

The mechanism for transmitting the power centrally to each of the two rocker shafts is of a new design, its aim being the reduction of any tendency to torsion between these shafts, the construction being so simplified that power need be transmitted from the crank

shaft on the one, or left hand side only, thereby eliminating an additional drive or mechanism for transmitting the power from each of the two sides. These new features, combined with the patented toggle movement adopted on the "Toledo" single crank presses secure the like advantages in the case of double crank machines, as those obtained in the single. The advantage is two-fold.

First, it permits more practical work in the drawing, especially on the thinner gauges of metal, where it is so very essential, and eliminates almost entirely the wasters so common in drawing work.

Second, the slight movement of the toggle arm and joint pin under the heavy pressure previously not only caused a variation in the pressure of the "dwell," but also tended to excessive wear on the pins. This, too, has been overcome in the new design.

The machine is built in a variety of

sizes and capacities, and of any required width between housings, by the Toledo Machine & Tool Co., Toledo, Ohio. The

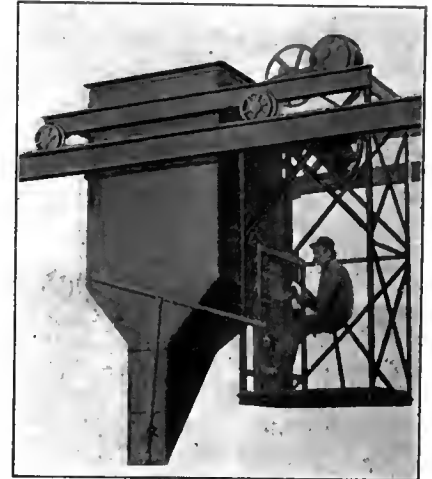

MOTOR DRIVEN COAL HOPPER.

dimensions of the press shown in the illustration are as follows:—

- Width between housings, 84 inches.
- Plunger stroke, 29 inches.
- Blank holder stroke, 18 inches.
- Weight complete, 135,000 pounds.



DELIVERING COAL TO BOILERS.

MOTOR-DRIVEN coal hoppers, which can take coal from bunkers located anywhere and deliver it to any boiler in a battery, are coming more and more into favor. Their use does away with the system of overhead bunkers and individual chutes for each boiler, and permits all the coal to be concentrated in one bunker instead of in a series of pockets. The bunkers can be placed at one end of the boiler room, or, for that matter, outside, if necessary, so that the boiler room can be designed and located with greater freedom, and plenty of space can be left above the boilers for light and air. This system is also frequently preferred to conveyors because it is cleaner, less liable to break down, cheaper in first cost, and does away with the difficulty of taking care of the surplus overflow which a conveyor will carry on to the end after the intermediate discharge gates are closed.

The hopper runs on a trackway parallel to the front of the boilers and is controlled by an operator in the same manner as an overhead crane. Accurate scales on the hopper make it possible to

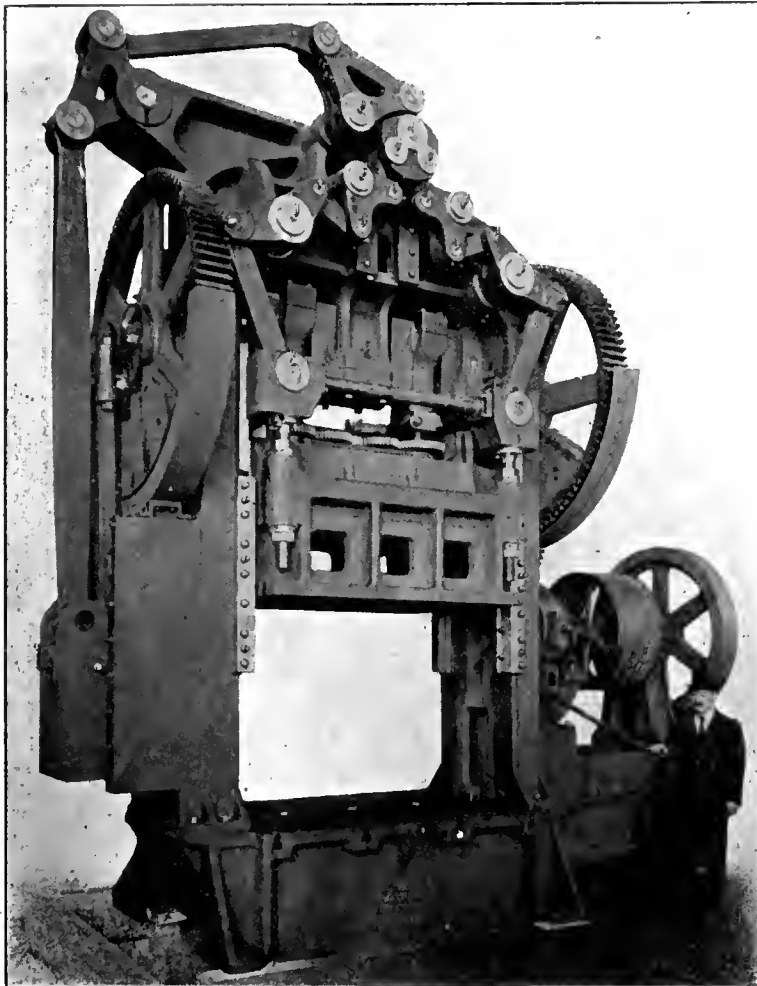

"TOLEDO" NO. 268 $\frac{1}{4}$ DOUBLE CRANK, DOUBLE ACTION TOGGLE DRAWING PRESS.

keep a precise record of the fuel burned by any boiler. If desired, a recording device can be installed so that a printed record of the weight of every discharge can be made by the operator. The hopper runs under the bunker and is filled by the operator, the scales indicating when the hopper is full. It is then run into the boiler room and delivers coal where wanted.

The hoppers are manufactured by the Bergen Point Iron Works, Bayonne, N.J., and Westinghouse motors are used to propel them.

NEW DUPLEX HORIZONTAL DRILLS.

THE illustrations show a new line of duplex horizontal drills recently brought out to thoroughly cover the benefits of machining work from opposite ends simultaneously, with suitable fixtures for drilling, counter-boring, turning or hollow-milling. Facing is not only done in practically one-half the time consumed in single spindle operations, but the alignment provided by the machine is a further advantage. Rapidity of operating the machine depends very largely upon the style of fixture used.

With a view to entirely avoiding chip troubles, the present design has large V style guides for the head, leaving an open bed free from the accumulation of chips. The No. 00 size of machine is made with both screws and rack feed, and of capacity for $\frac{7}{8}$ -in. and $\frac{3}{4}$ -in. drill respectively. The rack feed machine shown in figs. 1 and 2 is made in four distinct styles (A), (B), (C) and (D), with the head sliding on generous Vees, and taper gibbed underneath against the lifting strains and wear.

It will be noticed that centrally lo-

ated is a depressed surface, 12-in. x 12-in., with a centre (T) slot planed out of the solid square with the Vees, allowing provision for clamping fixtures and the quick interchange of same. The thrust of the spindle is taken on ball races. The heads of the No. 00-A duplex horizontal drill shown in fig. 1 are controlled independently by hand capstan wheels, suitable micrometer stops being provided for accurate facing work. The capstan wheels have two working positions for long or short pieces. On the (B) style the heads are moved simultaneously by hand through a centrally located capstan, operating through rack and pinion feed. By means of a friction clutch device, the left-hand head can be disengaged, allowing for a close adjustment to cover the variation in length of drills or turning tools. It also acts as an adjustment for wear of tools in sharpening. With this independent friction adjustment, various other uses, such as turning to exact shoulders or facing to exact lengths, are fully controlled.

The (C) style shown in fig. 2 is identical with the (B) style, having all the adjustments, but equipped with power feed, to feed both heads simultaneously. There are three changes of feed, automatic adjustable trip stops and micrometer stops. A specially noticeable feature is that on the tripping of the feed, the heads are returned immediately to their original position through the unwinding of an adjustable barrel spring. The spindles are hardened and ground and run in bronze boxes.

The (D) style is made to cover numerous special requirements in duplex drilling by replacing the sliding heads with sliding plates. On these sliding plates can be mounted various single or

multiple drilling heads, fed independently by hand, as in style (A), simultaneously by hand, as in style (B), or with automatic power feed, as in style (C).

These machines are a part of the line of duplex horizontal drills made by The Garvin Machine Co., Spring and Varieck Streets, New York City.

THE ROCKFORD HEAVY PATTERN PLANER.

THE Rockford heavy pattern planer has been designed to withstand the present up-to-date manufacturing requirements, and to a few of the more important features of the machine this description draws particular attention.

The beds are 1-2-3 longer than the table; the cross girders in the bed are of box section, 20-in. centre to centre, and the shaft bearings are bored to jig and bushed. The housings are also of box section, and extend down over the full depth of the bed; those for 32-in. and larger being finished to receive side heads, which can be furnished any time and attached without trouble. The saddles are of solid construction, eliminating the usual clamp, and are fitted with taper gibs for top and back of rail slide. They are right and left, allowing tools to be used close together, without reducing the width of the saddle bearing on the cross rail. The saddles are graduated around the entire circle, allowing heads to be adjusted from either side of the machine. The side heads have horizontal, vertical and angular power feeds, and aluminum drive pulleys eliminate shock at reverse and prevent shrieking of belts. The table has a dirt-proof feature, which

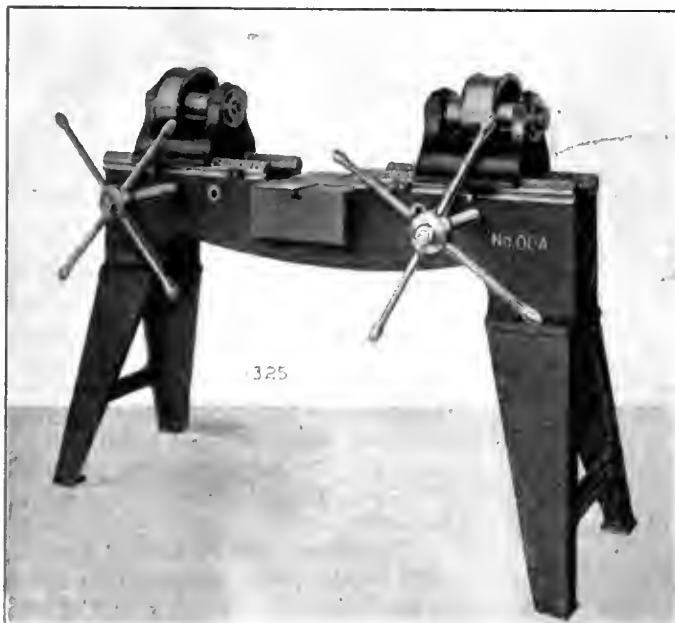

FIG. 1. GARVIN NO. 00-A DUPLEX HORIZONTAL DRILL LATHE.

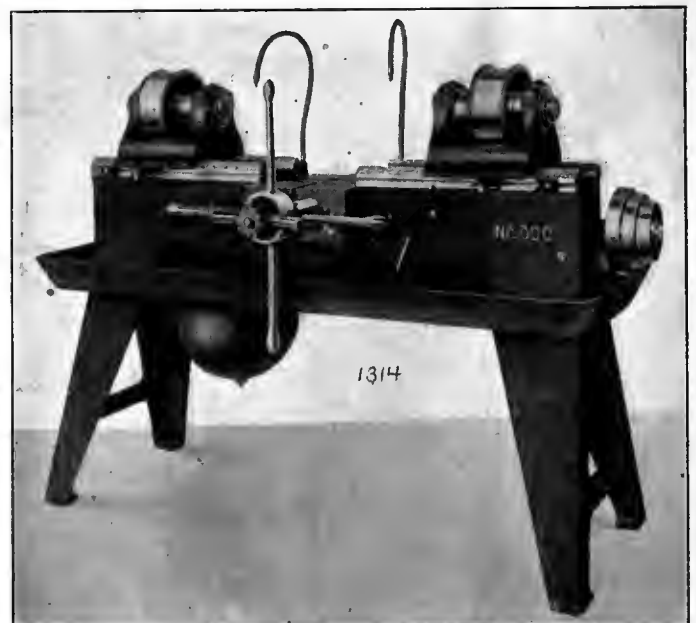
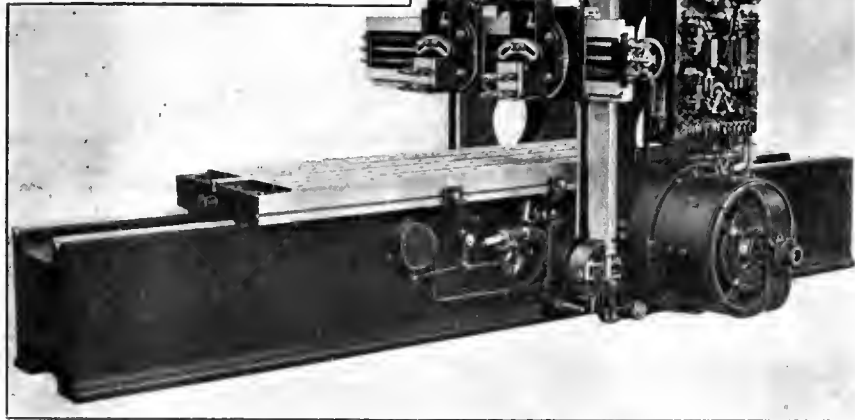

FIG. 2. GARVIN NO. 00-C DUPLEX HORIZONTAL DRILL LATHE.

prevents grit from entering the vees, and the drive gears are all inside of the bed and out of the way of falling chips. The feed friction is of the double releasing type, designed to run at high speed without heating. A safety lock on the operating lever prevents the planer starting, except at will of the operator.

Reversing Motor Drive.

The reversing motor drive has been arranged with a view to simplicity and the elimination of the features liable to



"ROCKFORD" 36 x 36 x 10 REVERSING MOTOR PLANER.

cause trouble. The motor with special frame is bolted direct to the pad provided on the housing, making the machine self-contained and overcoming the annoyance and trouble of keeping it and the motor in perfect alignment when each is placed on separate foundations. This adaptation also shortens the shaft, reduces the number of bearings, eliminates the coupling, avoids the dangers of an exposed shaft and coupling, and saves considerable floor space. When desired to dismantle the motor for repairs or examination, the armature is easily removed by driving out the gib head key and taper pin from the main drive pinion and set collar, and removing the outside head from the motor frame. This type of drive does away with all belts, belt shifters and countershafts. A separate motor is used for elevating the cross rail, and is operated from the left hand side of the machine.

The "Rockford" heavy duty planer is a product of the Rockford Machine Tool Co., Rockford, Illinois.



QUICK CHANGE GEAR ENGINE LATHE.

THE text and illustrations refer to the Quick Change Gear Engine Lathes built by the Cincinnati Lathe & Tool Co., Oakley, Cincinnati, Ohio.

Some months ago we published an illustrated descriptive article on the new plant of this firm at Oakley, where they,

together with some seven other firms, have formed a manufacturing colony, the heat, light and electric power supply for which is derived from a central plant. The advantages accruing from such an arrangement are too obvious to need further comment.

Each lathe is furnished with double wall apron, chasing dial, automatic stop, cabinet leg, plain or compound rest, centre rest, follow rest, large and small face plates, necessary wrenches, self-oiling friction countershaft, etc. Any length of bed as also the following attachments are supplied when called for:

Turrets on carriage or bed; oil pan and pump; taper attachment; relieving attachment; draw-in attachment; turret tool post; raising blocks; chucks; lathe tools, etc.

The headstock is made in three styles—three step cone with double gears, four and five step cone with single back gears. It is rigid and well proportioned to absorb all vibration due to heavy cutting. The spindle is of high carbon forged steel, ground and lapped cylindrically true, and with collar at nose end supplying a good stiff bearing when chucks and plates are on it. Boxes are of best quality bronze bearing metal.

The thrust bearing at rear end of spindle consists of a hardened tool steel collar for adjusting the wear. The end thrust is taken against the front end of back box. Lubrication of spindle bearings is provided for liberally by self-closing dust proof oilers on caps, through ample grooves in boxes insuring a continuous supply of clean oil. The apron is bolted rigidly to the carriage, and is of box type construction, which gives a double support to all shafts and studs mounted in it, providing for accuracy as well as long life of all the working parts. All gears are of ample pitch to withstand any cut the main driving belt will pull.

The rack pinion is made of steel, well supported and close to the rack on bed.

The Cincinnati lathes are designed with a view to the production of accurate work, and are therefore heavy of construction generally, and carefully proportioned with that end in view. All parts are machined in jigs, sliding surfaces are scraped to surface plates, and cylindrical parts are fitted by grinding and lapping. Castings are of hard close-grained iron. The beds are of semi-steel strongly braced internally by numerous

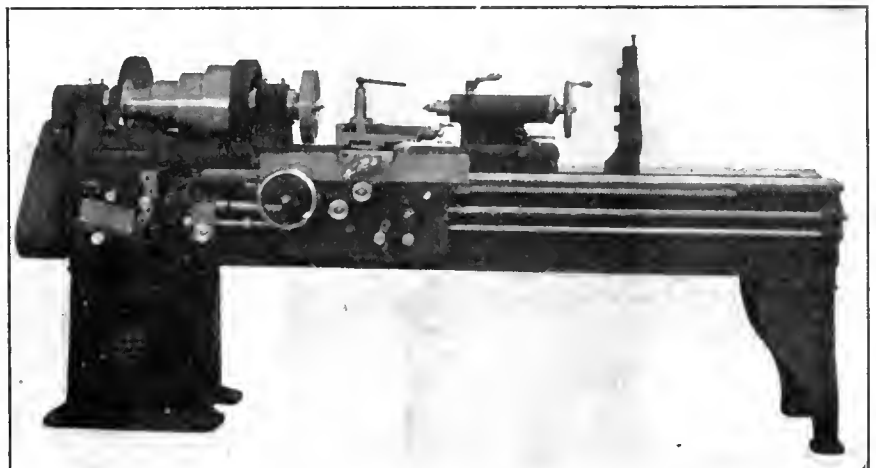

CINCINNATI QUICK CHANGE GEAR ENGINE LATHE WITH 3-STEP CONE AND DOUBLE BACK GEARS.

box section girths, of such depth and width as ensures rigidity under the heaviest cuts. Feed gears, pinions and gears subjected to the severest strains are made of steel.

Motion to it is transmitted by compound gearing. Longitudinal and cross friction feeds can be started, stopped or reversed while lathe is running but cannot be engaged when cutting screws; this

latter provision is an important safeguard especially when the lathe is in the hands of inexperienced operators. A thread chasing dial is provided which permits the half-nuts to be opened, the carriage to be run back by hand and the thread to be caught or picked up at any point without reversing lathe, so that a backing belt is unnecessary. There is also an automatic stop for throwing out the feeds. Carriages are gibbed both in the front and at the back, having a bearing the entire length on the V's of the bed.

The reverse plate for cutting right and left hand threads is on the outside of the head stock, and is used only for reversing lead screw when cutting threads, and not for reversing feed. These machines have feed reverse in apron.

The screw cutting and feed mechanism is characterized by its simplicity, compactness, ease of manipulation and strength. The device is complete in one unit, assembled in a box mounted on front of bed, allowing of easy access. Every gear in it is made of steel. Shafts are of liberal proportions eliminating all spring. The standard threads are made from one to another without duplicating or removing a gear by simply operating two levers conveniently placed a few inches apart. In addition to this, it

gives an unlimited range. The index plate is attached to box and placed so that the operator will know at a glance the correct setting for any thread or feed.

the driving belts, nor stop the countershaft when filling these bushes. Hangers are of pressed steel, heavy, of the double brace type and have ring oiling bearings.

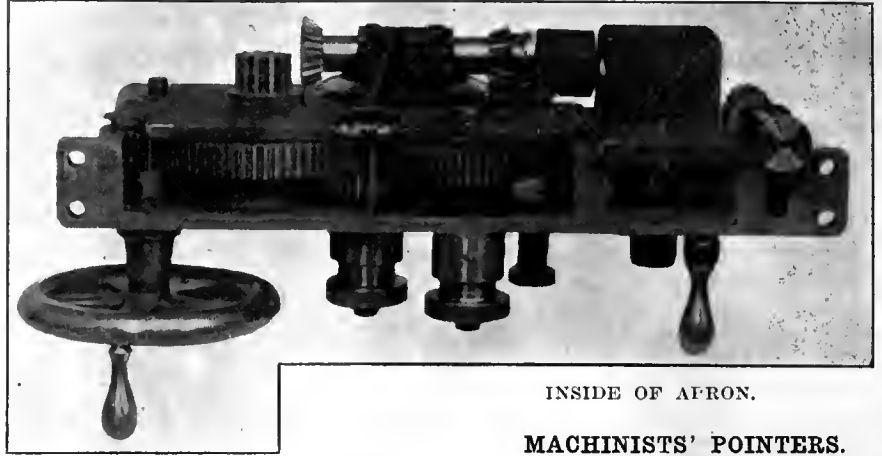

INSIDE OF APRON.

MACHINISTS' POINTERS.

By E. W. Tate.

The tailstock has a long bearing on the bed, and is massive and well ribbed. It is of the offset type, allowing the compound rest to be set in a plane parallel with the bed.

Countershafts are furnished with double friction self-oiling clutch pulleys, run on bushes that hold enough oil for a month. It is not necessary to throw off

It will be to the advantage of a machinist if he will remember the following:—

By the use of a knurling tool, a shaft which has been turned too small can be enlarged from 0.010-in. to 0.020-in., after which it can be re-turned or re-ground.

The size of the hole in a ring or similar piece may be reduced as much as 0.006-in. by heating to a cherry red and immersing about one-half the thickness of the wall in water, which, in cooling, will force the remaining stock of the wall toward the centre, thereby allowing the hole to be re-bored.

When filing a piece of wrought iron in the lathe, the clogging of the file may be obviated by bearing down slightly on the file on its return stroke.

In pouring a babbitt box, success will follow if the following rules are observed:—

- 1.—Always have plenty of vents.
- 2.—Have the babbitt as hot as possible.
- 3.—Pour as fast as the metal will run through the pouring hole.

All bearings for nuts and heads of cap screws should be spot faced.

A fair day's work well done, good habits and a good name keep pretty close company.



Welland, Ont.—Crowland Township recently carried unanimously the by-law fixing the assessment of the Metal Chemicals property and plant to be erected, at the sum of \$20,000 for a term of 20 years. Fred L. Blackinton is the trustee for the new company, and Raymond & Spencer are applying for a charter. The construction of the new plant will be commenced at once. It will employ from 200 to 300 men.

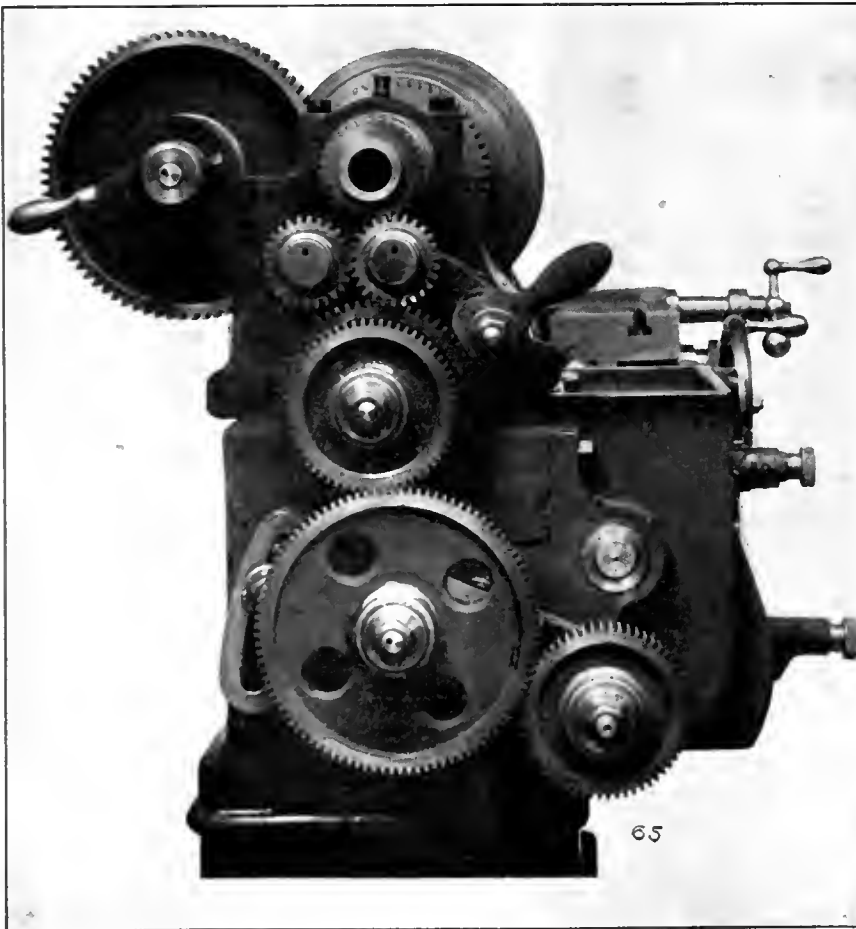

END OF LATHE WITH COVER REMOVED, SHOWING REVERSE PLATE AND SEGMENT.

N.T.R. TERMINALS AT QUEBEC.

WORD comes from Quebec City that Messrs. M. P. & J. T. Davis, contractors for the construction of the Nat. Transcontinental terminals in that city, have been order to proceed hastily with the work, in order to have them ready for the traffic which will ensue from the completion of the road from Winnipeg to Quebec next fall.

The contractors now have several hundred workmen engaged in finishing up the work of blasting and levelling the Transcontinental property on the heights of Cape Rouge surrounding the approaches to the bridge, besides many stonecutters and masons at the building of the bridge piers to get the structural work ready for the superstructure as soon as practicable.

The Harbor Commission will undertake the work of building the terminal docks for shipping and the necessary grain elevators along the river frontage parallel with Champlain street and in the coves west, but for the present a dock 4,000 feet in length, 2,000 feet on either side of the car ferry landing at Wolfe's Cove, running lengthwise with the river, will be built to accommodate ocean steamers handling traffic that will come from the west over the Transcontinental for export.

The first of these docks to be built will be gradually extended to meet the demands of shipping and the coves from Point au Pize to the Cap Blanc church, a distance of two and a half miles, will be filled in, thus giving considerable space for car yards.

The docks for shipping at Wolfe's Cove will necessitate the construction of a grain elevator in that vicinity.

The location for the Transcontinental workshops is not yet decided. Two sites are under consideration, one at Cape Rouge and the other at St. Malo.

**WANTS MORE BUSINESS—THE BUSY WEST.**

THE growing West seems still to dominate. Only yesterday Mr. Joseph Tracey, recently appointed industrial agent for Lethbridge, was in Montreal, and he told of their doings. He was accompanied by W. A. Buchanan, M.P. for that district, and they were both loaded with optimism regarding Canadian West. Mr. Tracey said he held a mandate from his Municipal Council to do all in his power to induce industrial concerns from Eastern Canada to locate in the West. Further, they were after British and American firms, and would send a long arm of publicity hot foot after them. He explained that Lethbridge is a great coal mining centre, and the pay roll there

ran often over three millions a year. He said they had two breweries, two flour mills and three extensive planing mills, and were brimming with anticipation of many industrial plants pitching their tents in the town at an early date.

Mr. Buchanan said that, although he was a Liberal, he was a moderate protectionist, and admitted that with four or five cities of a hundred thousand or more population, ranging from the Great Lakes to the Rocky Mountains, there would be no such thing as a free trade sentiment in the Western Provinces.

**THE LABOR SITUATION IN MONTREAL.**

WORK seems plentiful all over the Dominion, but, as Montreal is the natural gateway of the country, especially when the navigation season opens, it is interesting to record the situation from a "help wanted" standpoint. Old timers state that never has there been such demand for unskilled labor. The opening up of the wharves gives work to hundreds, but, aside from this, there are reasons paramount in the new work of building in the city.

Railway construction is particularly brisk. In addition to the construction work on the C. P. R. and the Transcontinental and the Western lines of the Canadian Northern, there will be actively pushed this year several new lines, including the Central Railways from Midland to Montreal, the North Railway from Montreal to James Bay, and the new entrance of the C. N. R. to Montreal, all of which are concentrated essentially in Montreal. In addition, large numbers of workmen will be employed at once on civic construction work, manifold improvements on sewers, water systems, conduits, tramways and public buildings.

The activity is evidenced by a glance at the lists of the large employment agencies. These are invariably filled with glowing demands for workers on railways and buildings, carpenters and bricklayers always receiving first choice.

Everything is in full swing at the wharves, where seven or eight ocean steamers have arrived, and longshoremen have been signed on. Other gangs are signed on for the summer, and the rush has started.

**LARGEST COMMERCIAL SWITCHBOARD IN THE DOMINION.**

THE C. P. R. Windsor Street Depot, Montreal, has the honor of having installed the largest telephone switchboard in the Dominion—that is, it is the largest commercial switchboard, having a capacity for twelve hundred lines.

The telephone room is situated in the old tower, and is well lighted and ventilated, and of such a size that if it is necessary at any future time to extend the switchboard, ample room for such extension is provided. In arranging this important department the company has had the comfort of the operators in mind and a special rest room has been prepared immediately above the operating room. This is being furnished with easy chairs, sofas and reading material, and everything has been done to make their quarters comfortable and home-like.

The new switchboard is what is known as the No. 4 Lamp Signal Multiple Board, and has a great many improvements which were lacking in the old one, such as lamp line signals, audible busy tests and lamp disconnect signals. At the present time it takes eight operators to handle the business, and has an ultimate capacity for ten positions. The board has been divided into two sections, the first four positions handling originating business and the other four the incoming business. Each position consists of two panels, making sixteen for the whole board.

At the moment the board is wired for 500 local lines and 100 trunk lines, the limit capacity as stated being 1,200 lines and 160 trunk lines. There are 225 local lines in use and 50 trunk lines, which will shortly be increased by 50 and 40 respectively. During one day a total of 7,180 calls were handled, an average of 900 calls per operator per day. On Saturday last one hour tallies showed that 1,028 calls were disposed of. This tremendous number of calls necessitates an exceedingly fine class of operators, and those at the C. P. R. under the jurisdiction of the Telephone Company have been specially and thoroughly trained in every phase of the business. The majority have had years of experience with the C. P. R. and its officials and employees.

The board is operated from 8 a.m. until 10 p.m., including Sunday, and in order to maintain these hours and make allowance for reliefs and days off when working on Sunday, a staff of twelve operators and one supervisor are needed all the time.



Montreal, Que.—The various changes which have recently taken place in the Allis-Chalmers organization have necessitated the removal of their city sales offices from the Canadian Express office building to 162 St. Antoine St.

The Zorra Telephone Co., Ltd., incorporated at Toronto, to carry on a telephone service within the townships of West Zorra, East Zorra and East Nisour. Capital, \$6,000.

The MacLean Pub. Co., Ltd.

(ESTABLISHED 1884.)

JOHN BAYNE MACLEAN - - - - - President
H. T. HUNTER - - - - - General Manager

PUBLISHERS OF

CANADIAN MACHINERY

AND MANUFACTURING NEWS

A weekly newspaper devoted to machinery and manufacturing interests, mechanical and electrical trades, the foundry, technical progress, construction and improvement.

H. V. TYRRELL - - - - - Business Manager

OFFICES:

CANADA

Montreal, Rooms 701-702 Eastern Townships Bank Bldg.

Toronto, 143-149 University Ave., Phone Main 7324

Winnipeg, 34 Royal Bank Bldg., Phone Garry 2313

Vancouver, H. Hodgson, 2640 Third Ave. West.

GREAT BRITAIN

London, 88 Fleet Street, E.C. Phone Central 12960
E. J. Dodd

UNITED STATES

New York, R. B. Huestis, 115 Broadway, New York, N. Y., Phone 2209 Rector

Chicago, A. H. Byrne Room 607, Marquette Bldg. 140 S. Dearborn St., Chicago

CABLE ADDRESS:

Macpubco, Toronto. Atabek, London, Eng.

SUBSCRIPTION RATE:

Canada, \$2.00; United States, \$2.50; Great Britain, Australia and other colonies, 8s. 6d. per year; other countries, \$3.00. Advertising rates on request.

Subscribers who are not receiving their paper regularly will confer a favor on us by letting us know. We should be notified at once of any change in address, giving both old and new.

Vol. IX. MAY 1, 1913 No. 15

PRINCIPAL CONTENTS.

Handling Heavy Machines and Their Parts Under the Crane	453-457
Power Transmission Benefited by Belt Treatment.....	457-458
General	458
The Status of Engineers....British Trade with Canada.	
Discussion on Standard Cross-Sections and Symbols.....	459-461
General	461-462
Grain Elevators—Dredge Dipper Trips.	
High Speed Transmission Dynamometer	463-464
General	464
World's Output of Electric Steel—Test of an American Diesel Engine.	
Machine Shop Methods and Devices	465-466
A Cheap Jig....Chuck for Small Milling Cutters with Shank....Spring Testing Machine.	
General	466
Buoys for the Panama Canal Channel....Steel for Polson Dry Dock.	
Developments in Machinery	467-470
Double Crank. Double Action Toggle Drawing Press.... Delivering Coal to Boilers....New Duplex Horizontal Drills....The Rockford Heavy Pattern Planer....Quick Change Gear Engine Lathe....Machinist's Pointers.	
General	471
N.T.R. Terminals at Quebec....Largest Commercial Switchboard in the Dominion....The Labor Situation in Montreal....Wants More Business....The Busy West.	
Editorial	472
Industrial and Construction News	473-477
Engineering Electrical Waterworks Municipal Railways Bridges General Industrial....Building Notes....Tenders....Trade Gossip.... Personal....Nova Scotia Steel & Coal Co.	
Selected Market Quotations	476-479
General Market Conditions and Tendencies	479-480

THE ART OF SLINGING MACHINERY.

THE illustrated descriptive article in this issue, on "slinging machinery for lifting and moving under the crane" should be read carefully by every employee of our machinery manufacturing concerns, large and small, showing and describing, as it does, that in addition to there being method in protecting the piece being handled, from

damage due to the sling itself, there is further method in placing or arranging the latter, so that mishap through breakage or slip of the sling may be avoided.

It is the duty of every mechanic to familiarize himself with the manner of making knots, arranging tackle and placing slings properly and advantageously. There is produced nowadays such a wide variety of shape and structure in machines and their parts that no hard and fast rules are applicable, yet by carefully studying arrangements of sling adopted in a number of instances for lifting and moving heavy or light pieces, it becomes no difficult matter to determine just what will be the safest and most tradesmanlike method to apply in any case that may arise.

The practice of slinging machinery, complete or in part, offers, we believe, an opportunity for display of sound judgment and reason not otherwise available and certainly not to be surpassed in the cultivation of high degree intelligence.

TO THE APPRENTICE—BE A NUISANCE.

WE noticed the other day that the Provincial Government of Quebec appointed a Conservative to fill an important and lucrative position. The administration in Quebec just now is Liberal. This was a man who made himself person grata with both parties by being a nuisance. Ten years ago he was a rough looking emigrant; to-day he is a smart business man, with his finger on the pulse of the money market. Still, he is a nuisance, and that very quality has put him where he is. He is not blessed with an unusual brain—just normal; yet he will let you feel the full force of it, and he carries his ideas into high places. It is a common thing to see him in the office of Sir Lomer Gouin, the Premier of Quebec, telling that worthy what he thinks, and even Mr. Borden will lend an ear to what he says. The point is that he says what he thinks, and you know it, though what he says does not amount to a row of pins.

That idea might be carried profitably into the machine shop and foundry. There is a warning in the Bible against putting a light under a bushel. That's the point; and it must be an old one when it is in the Good Book, but it applies to the apprentice in the twentieth century shop, serving his time to be a machinist. If he is content to take rough cuts off forgings for six months, his foreman will say he is a steady man, a reliable man. If it were not so outrageous, our advice would be to that apprentice, "Make yourself a nuisance!" So many men there are in this world who have become eminently successful by pushing themselves forward, it is evident that gall pays sometimes. Nine times out of ten the man who gets there is the one who is capable of infinite audacity.

The apprentice who has an idea should pass it on to his foreman. If it is useless, no harm is done, and he is, at least, on speaking terms with his superior. The day has gone by when the heads scorn the advice of inferiors. The progressive firm will pay its men who have ideas and who do not keep them to themselves. Thus the theory is put into practice that two heads are better than one. How many big concerns have been built up through an idea conceived by a workman who pushed himself forward?

The nuisance must have some brains, and if by chance he has a lot, his success will be quick and sure. There are lots of brainy men in the world who see improvements that might be made in their firm's methods; but they keep going in their old rut, never opening their mouths. Some day we hear the following murmur: "Why, I thought of that twenty years ago"—yes, but was not nuisance enough to draw it to the foreman's attention.

INDUSTRIAL ^A_N^D CONSTRUCTION NEWS

Establishment or Enlargement of Factories, Mills, Power Plants, Etc.; Construction of Railways, Bridges, Etc.; Municipal Undertakings; Mining News.

Engineering

Sutherland, Sask.—Mr. Graves is erecting a machine shop in Sutherland View.

Victoria, B.C.—The winding-up of the British Columbia Motor Truck Transportation Company is announced.

Levis, Que.—The Minister of Marine has stated it is not the intention of the Government to remove the Marine Department shops from Quebec to Levis.

St. John, N.B.—The Maritime Motor Car Co., of St. John, N.B., have joined forces with the Palmer-Singer Manufacturing Co., of New York.

Vancouver, B.C.—The roof and some valuable patterns were burned in a fire at the brass foundry of Wilson Bros., Dufferin Street E. The loss is covered by insurance.

Calgary, Alta.—The scheme for a municipal foundry has not been received with favor by the city commissioners. Mayor Ross has turned the matter over to the new Industrial Commissioner.

Bredenbury, Sask.—James Whipples, of Carlisle, Ind., the maker of the flexible steel harrow, is thinking of installing a plant here. He is negotiating with Secretary Kinney of the Board of Trade.

Bellville, Ont.—The Tivani Electric Company are making final preparations for beginning work early in May for the manufacture of steel directly from iron ore. The works will handle at the start two and a half tons of ore daily.

Brantford, Ont.—The core room of the Pratt & Letchworth Malleable Iron plant was destroyed by fire on April 23rd as well as considerable damage to the new molding shop. The loss amounts to \$25,000 and is fully covered by insurance.

Fort William, Ont.—Surveyors are laying out the property of the Maritime Nail Co. on estate No. 1. S. E. Elkin, of St. John, N.B., is on the ground and will remain there during the construction of the plant. The company will erect a plant for the manufacture of wire and wire nails, costing \$500,000, and will employ about 300 men.

Medicine Hat, Alta.—The International Supply Co. has let contracts for an addition 44x72 feet, to its foundry and a new factory building, 56x112 feet.

The large and fully equipped plant of the Maritime will be used to adapt the type, design and material of the Palmer-Singer Co. to the Canadian requirements, under the direction of experienced men from New York.

New Glasgow, N.S.—The Eastern Car Company, the subsidiary concern established and owned by the Nova Scotia Steel and Coal Company, is now engaged in manufacturing, and has orders on hand for over two thousand steel pressed cars. The company has promised delivery of these cars in August, and the plant will be worked at full capacity during the summer, with every prospect of further orders that will keep it running for the balance of the year.

Montreal, Que.—Grand Trunk Railway officials report that an order has recently been placed by that company with the Montreal Locomotive Works for 50 Mikado engines for use on their Canadian lines: also an order with the Baldwin Locomotive Works for 25 Mikado engines for their lines in the United States. The following are recent orders for box cars: 2,000 from the Canadian Car & Foundry Co.; 2,000 from the Eastern Car Co.; 3,000 from the Western Steel Car & Foundry Co.; 1,000 drop bottom special service cars from the Western Steel Car & Foundry Co.

Electrical

Ottawa, Ont.—The Government has glove factory for H. G. Smith will be built. General contractor, M. H. Hewitt.

Sarnia, Ont.—The Maekenzie Electric Company have completed the new refrigerating plant for the F. Kaupp meat market.

Stambridge East, Que.—The Board of Trade will ask the municipal council to pay for installing electric street lights in the village.

Calgary, Alta.—The building for the dry cleaning plant to cost \$8,000, 7th Ave. E., for the Empire Cleaning Co., are McDougal & Foster, Board of Trade Building.

Windsor Mills, Que.—It is reported that farmers in the vicinity of Hardwood Hill are trying to form a telephone company, for the purpose of connecting Hardwood Hill with Windsor.

Johnville, Que.—Another telephone company is expected here in the near future. The Eastern Township Telephone Co. have already a number of contracts signed and expect to build a party line from here to Martinville at once.

Govan, Sask.—The electric light plant was put in operation for the first time on Tuesday, April 15th. The equipment consists of a 20 H.P. Fairbanks engine and a dynamo capable of lighting 500 lamps. The work was done by Messrs. Henry and Sutherland.

Edmonton, Alta.—Ten miles of electric street railway lines in all will be built in Edmonton this year. They will be built by private interests, but the tracks, poles and wiring are to be turned over in two years. The cost will be between \$150,000 and \$200,000.

Montreal, Que.—At the annual meeting of the Maritime Coal, Railway and Power Company, Limited, held in Montreal, the president reported that the negotiations for the sale of a considerable block of the company's securities had been successful, and it was contemplated to carry out during the ensuing year large extensions to the power plant at Chignecto, and electrification of the colliery plant at Joggins' Mines, to cope with increasing demand for coal and electric power.

Regina, Sask.—The following contracts were passed by the Fire, Heat and Light Committee for approval of the council: Weather-proof Copper Wire—Northern Electric Company, 50,000 lbs.; H. W. Laird Co., 52,000 lbs.; Canadian Wire Cable Co., 25,000 lbs.; Deering Electric Co., 25,000 lbs. Cedar Poles—

C. W. Bacon, 1,510 poles, \$11,949. Cross Arms—Dawson & Co., 3,400 cross arms, \$1,073. Pins, Insulators, etc.—Dawson & Co.—\$2,565.45. Pole Line Hardware—Northern Electric Co., \$2,484.05. Transformers—Canadian General Electric Co., \$9,089. Meters—Chamberlain Hookham Meter Co., \$13,100. Chapman & Walker, \$7,490. Street Lighting Equipment—Three lighting equipments complete, Canadian Westinghouse Co., \$15,452. Series Cutout Mast Arms—Mainer Electric Co., \$2,325.75. Underground Material—Imperial Wire and Cable Co., \$549. H. W. Johns, Manville Co., \$664.58. Fire Alarm Equipment—Northern Electric Co., \$2,433. Mainer Electric Co., \$336.

Waterworks

Weston, Ont.—The town is borrowing \$40,000 to be spent on a sewage system and disposal plant.

Toronto, Ont.—The Ongiara, which used to be run by the R. and O. line between Queenston and Lewiston, is up for sale.

Cochrane, Ont.—A sewage extension to cost \$3,000 will be built. Engineer-in-charge, Suttcliffe & Neylands, New Liskeard, Ont.

Cochrane, Ont.—A watermain extension to cost \$6,500, is planned by the town council. Engineer in charge, Suttcliffe & Neylands, New Liskeard, Ont.

Vancouver, B.C.—The British Columbia Electric Railway will connect the North Vancouver ferry wharf with Dunderave, West Vancouver, with a car line.

Stratford, Ont.—The Council have passed a by-law providing for the construction of a trunk sewer across the southern portion of the city, tapping the Erie Street sewer, at an estimated cost of \$11,546.70.

Courtney, B.C.—Applications for licenses to take water from unnamed creeks in the Courtney district for municipal purposes are made by the Courtenay Waterworks Company. A storage reservoir of ten million gallons is proposed for conservation purposes.

New Hamburg, Ont.—Waterworks, to cost \$25,000, are planned. Three miles of pipe 10 in., 9 in., and 6 in., water tower of concrete, capacity 50,000 gals., 90 ft. high, turbine pump, electric motor, covered concrete reservoir, hydrants, meters, valves required. Town clerk, J. F. Katzenmuir.

Quebec, Que.—The work on the laying of a new 40-inch main from Corette to Quebec is being resumed. The work should be completed by December. Mr. Connolly who is superintending the work has purchased a new jointing machine and will probably buy another operating by compressed air.

Park Hill, Ont.—The contractors have the foundation for the new waterworks tower excavated. The foundation is 4½ feet deep, 6 ft. wide. The diameter from outside to outside is 29 ft. 4 inches. The tower is 107 ft., 4 inches high from bottom of base to top of dome. The tank on top of the tower will be 27 ft. in diameter inside and 29 ft. high, holding 100,000 gallons of water.

Testing Cast Iron Pipe.—Refusal by Messrs. Crane & Co., contractors for the supply of a large order of water pipe to

Vancouver, to sign the contract if tests of fitness had to be applied in Vancouver, led to a discussion at the civic water committee as to whether the pipes should be tested locally or at Pittsburg to ensure compliance with the specifications, the result being that the question was placed in the hands of the city engineer and purchasing agent to deal with. The opinion of the committee was that the pipe should be refused if it did not come up to specifications.

Miscellaneous

Hamilton, Ont.—The contract for building factory, costing \$14,000, for The Bell Thread Co., Ltd., 185 Yonge Street, has been let to H. Yeates, 24 Leeming Street.

North Bay, Ont.—The Government breakwater under construction in North Bay harbor, Lake Nipissing, was almost completely destroyed on April 22, by ice breaking up and shoving shoreward.

Toronto, Ont.—Prompt work by the fire brigade saved the John Street bridge from destruction last week. As it was the structure was seriously damaged. The iron girders underneath and the iron work along the side were twisted out of shape and part of the bridge was rendered unsafe.

Ottawa, Ont.—The Government has awarded to Albert Mackie, of Toronto, the contract for the construction of the Cape Tormentine pier in connection with the Prince Edward Island car ferry. The price is \$571,590. The pier at Carleton Point is to be built by the Halifax Dredging Company at a cost of \$799,495.

Brantford, Ont.—W. P. Kellett, chief engineer of the Lake Erie and Northern Railway, left for Ottawa on April 23 to interview Hon. Robert Rogers in connection with the dredging of Port Dover harbor. The Government is said to be favorably disposed towards the proposition and a line of freighters will be established between Erie, Pa., and Dover, whereby a big saving will be effected on the haul of coal and steel from the United States.

Municipal

Stanstead, Que.—The municipality commenced operations on its new road work on April 24th.

Sherbrooke, Que.—The road committee will purchase a steam ruck for hauling macadam at a cost of \$4,000.

Ottawa, Ont.—The Ottawa city council will engage an engineer to report on the cost of establishing a civic gas plant.

Welland, Ont.—L. W. McClellan, Toronto, is organizing a company for the purpose of erecting 100 workingmen's houses here.

Brandon, Man.—During the coming year the city will, if possible, construct 44,155 feet of sewers, at an estimated cost of \$104,155.

Calgary, Alta.—The ratepayers on April 24 voted in favor of spending \$643,200 on waterworks, \$25,000 on Bow River embankment, etc.

Russell, Man.—A by-law is to be submitted on the above date calling for the raising of \$18,000 to cover cost of installing an electric lighting system.

Richmond, Que.—The council will send a delegation to Montreal to watch operations of stone crushing plants and other machinery before purchasing their own.

Wingham, Ont.—The ratepayers on May 6th will vote on a by-law providing for a \$6,500 issue of debentures for the purchase of road machinery and a hose tower.

Walkerville, Ont.—The town council has completed plans for the erection of an incinerator for garbage disposal, steel construction, to have a daily capacity of 12 tons.

Calgary, Alta.—A modern factory building costing \$250,000, will be erected by the city and leased to manufacturers. Inspector Sylvester is going over the plans.

Hamilton, Ont.—The County of Wentworth is negotiating with the Buffalo-Pitts Co., of Buffalo, N.Y., for the purchase of a traction engine and wagons to cost \$4,200.

Unverton, Que.—The citizens are strongly in favor of borrowing \$50,000 from the provincial government to macadamize the highways. The town council will take the matter up.

Woodstock, Ont.—It is contemplated that a by-law will shortly be submitted to the ratepayers whereby \$12,000 will be raised in co-alliance with the recommendation of the water and light commission.

South Vancouver, B.C.—The result of a vote on the money by-laws recently submitted to the burgesses is as follows: To raise \$575,000 for roads; \$30,000 for sidewalks, and \$130,000 for waterworks were passed.

Peterboro', Ont.—Power was recently granted the city by the Provincial Legislature to issue debentures, payable within 20 years, and bearing interest at 5 per cent., to the extent of \$10,000, to cover cost of an incinerator.

Kingston, Ont.—The city has received word from the Marine Department at Ottawa, that it will have to bear the cost of lighting the new bridge which the Government is building to replace the old Catarauil bridge to Barrielfield.

London, Ont.—The Board of Works will build two new coke beds for sewage disposal, costing \$14,013. Other improvements to the sewage disposal plant are being made. Bridge and culverts will cost \$4,570 and temporary repairs to the West London breakwater will cost \$1,000.

Calgary, Alta.—The ratepayers ratified by-laws on April 23 providing funds for various public improvements as follows: Rehabilitation of water plants, \$643,200; publicity, \$12,000; smallpox hospital, \$12,000; embankment on Bow River, \$25,000; children's shelter, \$50,000.

Welland, Ont.—The city council is sending for information on a reduction or disposal plant for garbage which would pay a profit over the cost of operation. Town engineer Black and the Chairman of the Board of Health, with others, have the matter in hand.

Railways—Bridges

Orangeville, Ont.—The township of East Garafraxa will spend \$13,000 on bridges.

Burnaby, B.C.—The corporation will borrow money to build an electric railway system here.

Ottawa, Ont.—The City and Gloucester Township will each bear half the cost of repairing Billings' Bridge.

Swan River, Man.—A by-law will be submitted to the people to provide money for installing an electric lighting plant.

Ailsa Craig, Ont.—The Grand Trunk bridge gang is preparing cement work and girders for a new bridge over the Sauble here.

Montreal, Que.—The Montreal Tramways Co. have planned a new route, ordered 200 new cars, and contemplate ordering 200 more.

Brome, Que.—The town will build a new steel bridge 16 feet wide by 33 feet long with concrete abutments. Mayor Bullard is in charge.

London, Ont.—President E. J. Chamberlain, of the G. T. R. announced last week that a line from Port Burwell to London has been planned.

Toronto, Ont.—Reconstruction of the big steel bridge crossing the railway

mers-Bullock, 2 lidg. unloaders; from tracks at the foot of Strachan Avenue is contemplated by the city, and application for permission will be made.

Quebec, Que.—Messrs. M. P. and J. T. Davis, contractors for the building of the Transcontinental Railway Terminals at Quebec, are now under orders to proceed with the work at once and to hurry it to completion.

Montreal, Que.—Plans are being prepared for the city terminus of the C. N. R. and work on the station buildings will commence during the summer. Plans for the station are being prepared by Warren & Wetmore.

London, Ont.—The expenditure of \$25,000 in steel rails, etc., for the purpose of improvements in the city street railway system and the addition of six new "pay-as-you-enter" cars, now under construction, has been made by the London Street Railway Co.

Kenora, Ont.—Work has been started here on the six-stall addition to the C.P.R. round house, and a gang of men are engaged in excavating the foundations. The addition will be placed on the north side of the semi-circle building. The cost of the structure will be about \$30,000.

Brantford, Ont.—Work has already commenced on the Lake Erie and Northern Railway from Galt via Brantford and Port Dover. Efforts are being made to have the track completed between Brantford and Galt by October. The track to Port Dover will be completed by May, 1914.

Rolling Stock Output.—During the two weeks April 3rd to April 17th, the rolling stock output of the C.P.R. was as follows: From Canada Car & Foundry, 405 box cars, 125 flat cars; from Barney & Smith, 92 box cars; from Nat. Steel Car, 134 box cars; from Angus Shops, 6 baggage and express, 7 sleepers, 13 suburban, 5 tourist; from Mussens, Ltd., 3 steam shovels; from Allis-Chalmers & Co., one ballast spreader; from Angus Shops, 4 G-2 locomotives.

Welland, Ont.—The Street Railway Co. are laying new tracks for extensions which they hope to complete this summer. A new bridge will be built across the river. C. J. Laughlin, vice-president of the company states that extensions to Dain City and Port Colborne will be commenced shortly.

Electric locomotives, able to haul 1,000 tons of freight, will be used. The company will establish car shops in Brantford, and all the electric locomotives and cars will be repaired in that establishment. There will be an hourly service all over the line, and Galt will be

made in 60 minutes and Simcoe in 60 minutes.

The run to Port Dover will be 1 hour and 20 minutes. In the event of the Government making an appropriation to dredge Port Dover harbor, a ferry service will be at once established between that point and Erie, in New York. It is expected to carry coal and steel from there to Brantford, Paris, Galt, Berlin, Preston and so on, and very likely to Toronto over the C. P. R. tracks.

General Industrial

Armstrong, B. C.—The Okanagan Valley Clay Works will build a large plant here this year.

Melfort, Sask.—Dawson & McEwan, grain dealers, will build a grain elevator at Raleigh, Sask.

Peterboro', Ont.—By a majority of over 900 a by-law to aid the Vermont Marble Company was endorsed here on April 22.

Souris, P.E.I.—A roller flour mill will be built by H. H. Acorn, manager Klondike Lumber Co., in conjunction with his other plant.

Wallaceburg, Ont.—The Sydenham Glass Co. are in the market purchasing new machine tool equipment for their new plant at Redcliff, Alta.

Montreal, Que.—The Smart Bag Co. will, it is reported, establish two new factories soon, one at Saskatoon, Sask., and the other at Vancouver, B.C.

Tillsonburg, Ont.—The Snedcor-Hathaway Co., shoe manufacturers, of Detroit, will move their plant here, the town having promised to lend them \$25,000.

Hamilton, Ont.—A pattern storehouse and machine shop, cost \$10,000, will be built for Canada Steel Co., Sherman Ave. north. Architects, Prack & Perrine, 36 James St.

Lake Meganic, Que.—The burgesses have expressed themselves in favor of a by-law to raise \$7,000 as a loan to P. Cliche for the establishment of a broom and brush factory.

Port Arthur, Ont.—Messrs. Davidson & Smith, Fort William, will build a large flour mill here and an elevator. The city will guarantee their bonds to the extent of \$375,000.

Saskatoon, Sask.—The new winter fair building will be built on the site of the industrial building, and will be 320 feet long. Plans are being prepared for a building costing not more than \$150,000.

Edmonton, Alta.—With the idea of establishing a paper and straw board plant costing approximately \$250,000, at a location in this city, J. W. Simpson, of Worcester, Mass., is visiting Edmonton.

Peterboro', Ont.—The Bonner-Worth Co., Ltd., plan to erect an addition to its spinning plant at a cost of \$12,000. The building will be two storeys, 70x80 ft., of white brick construction, stone foundation.

Dundas, Ont.—The Cockburn Lumber & Concrete Co., Ltd., with \$100,000 capital, will build a plant here, on a site recently secured, and will manufacture cement bricks, posts, etc. J. W. Cockburn is president.

Owen Sound, Ont.—The Dorice Cement Company will begin active manufacturing in the course of the next week, and will turn out their full capacity of 30,000 barrels of rock cement each month for the full summer season.

St. Catharines, Ont.—The Canada Carbide Works at Merrittion were damaged to the extent of eight or ten thousand dollars on April 24 by a fire supposed to have started from a spark. The loss is principally to the electric machinery.

Cargill, Ont.—The planing mill, grist mill, foundry, stave mills, model farm industries promoted by the firm of H. Cargill & Son are to be extended and developed by a Joint Stock Co. known as Cargill's Limited, capitalized at one million dollars.

Saskatoon, Sask.—Cushing Bros. & Co. have commenced work upon an addition to their large planing mill and wood turning factory. The addition will be 90x110 feet, two storeys and basement. The building will be of brick, and will cost about \$18,000 or \$20,000.

Galt, Ont.—The failure of the Pledsted Construction Co. has brought together a large crowd of creditors and other interested parties. A committee has been named to consider forming a new company to keep the business up as a going concern. The liabilities are \$100,000.

Scotstown, Que.—The promoters and shareholders of the Scotstown Manufacturing Company held a largely attended meeting Monday last. Four thousand dollars' worth of stock was subscribed, and the provisional directors of the new company were chosen, and work planned.

Halifax, N.S.—The Rhodes Curry Co., Ltd., will build a large and modern warehouse to replace the one recently destroyed by fire. In the meantime the firm have acquired the DeWolf carriage factory as a temporary warehouse, where large quantities of stock are arriving daily.

Barrie, Ont.—The Underhills, Ltd., plan additions and improvements to their hoot and shoe factory, estimated to cost \$10,000. Two storeys will be added to the old building, and a new four-storey building, 48x40 feet, of brick construction with concrete foundation, will be erected.

Sydney Mines, N.S.—The discovery of a new coal seam on the property of the Nova Scotia Coal & Steel Company in this vicinity is reported. The officials are now seeking to secure 1,500 men and will take immediate steps to check the flow of emigration toward the West this summer.

London, Ont.—The erection of a modern gas plant costing \$150,000 is contemplated by the City Gas Company. The new buildings will be erected on the present site at the corner of Horton and Ridout Streets. Work on the buildings will not be commenced until the question of natural gas is settled.

North Bay, Ont.—The new power dam under construction at Abitibi Falls for the Iroquois Falls Pulp & Paper Company was carried away last Saturday morning and two workmen lost their lives. The accident was caused by high water, the Abitibi River being swollen to an extent never before known.

New Directors.—The International Engineering Works, Limited—the reorganization of Robb Engineering Company, Limited, with works at Amherst, N.S., and at South Farmingham, Mass., have elected these directors for the ensuing year: C. H. Cahan, H. A. Lovett, R. Brutinel, R. Garrett, D. W. Robb, and C. H. Cahan, jr.

Castlegar, B.C.—Fire wiped out the planing mills of the Edgewood Lumber Company's plant at Castlegar, B.C., with a loss of about \$14,000. Already a temporary planer and engine have been taken to Castlegar and are being worked in connection with the mill. As soon as the necessary arrangements can be made a new planer will be built.

Owen Sound, Ont.—On Monday the new plant of the Canadian Malleable Iron Company began to operate, and the first casts were made. Sixty molders have arrived, besides about 100 laborers. The number of workmen will be doubled in the course of the next month. An addition is contemplated that will double the present 5,000-ton capacity of the works.

Cobourg, Ont.—J. Cassidy, of Long & Burnham, New York, was in town recently, looking for a suitable place for a factory. His firm manufacture sectional iron frame commercial greenhouses and boilers. Their factories are at Irvington, New York, and Des Plaines, Illinois.

They wish to open up an establishment in Ontario.

Sarnia, Ont.—It is expected that in the near future the Imperial Oil Company will increase its plant here by eighty per cent., and the number of employees by several hundred. When the new pipe line to the Ohio oil fields has been completed, the company will have a steady supply of crude the year round, which means that the plant will be able to run to full capacity without the crude being stored in the tanks when it is brought in during the open season of navigation.

Toronto, Ont.—The British Canadian Cannery, Limited, which was organized a little over a year ago, and immediately constructed several plants in Ontario, has just completed arrangements for the construction of two additional factories at Port Dalhousie and Blenheim. Work will be commenced at once, so that they will be ready in time to handle the coming season's crop. On the completion of the factories the company will have seven of the most modern canning plants in Canada.

Saskatoon, Sask.—J. F. Tiefenbach, of Red Wing, Minn., will start at once to build a \$100,000 flour mill at Factoria, Sask., north of Saskatoon. Machinery has been ordered, and will be electrically driven. The milling machinery has been ordered from the Great West Mill Machinery Co., at Leavenworth, Kansas; the cleaning machinery from Silver Creek, N.Y.; the dust collector from Milwaukee, and all the shafting from the Strong, Scott Co., of Minneapolis and Winnipeg.

Building Notes

Ottawa, Ont.—Plans are being made by Blackburn Bros. for the erection of an 8-storey building on Rideau and Sussex Streets, measuring 65x86 feet. W. E. Noffke is the architect.

Toronto, Ont.—It is likely that the contractors on the construction of Toronto's new Technical School, will begin work in a few weeks. Solicitor Brown was instructed by the Board of Education at a special meeting last week to immediately draw up and execute the contracts.

Tenders

Welland, Ont.—Tenders will be received up to May 5 for Sewer Connections from Street Sewer to Street lines on West Main Street between Fraser Street and Catharine Street. Sealed tenders to be addressed to C. Webber, town clerk.

Strassburg, Sask.—Tenders will be received at the office of the secretary-treasurer for an electric light plant for the town, up to Tuesday, May 20th. Specifications can be had by applying to S. L. A. Smyth, secretary-treasurer of Strassburg, Sask.

Lytton, B.C.—Tenders for the manufacture and delivery of material for the steel superstructure of a bridge across the Thompson river will be received up to May 7. Plans and specifications may be had at the office of J. E. Griffith, engineer of public works, Victoria, B.C.

Hamilton, Ont.—Tenders will be received by John Allen, the Mayor, up to Tuesday, May 6th, for the construction of re-inforced concrete sewage tanks, conduits, sludge drying beds, pile foundations and other structures required for the complete erection of the West End sewage disposal plant. S. H. Kent, City Clerk.

Quebec, Que.—Tenders will be received until May 4th for two cement abutments to receive a steel bridge crossing the Missisquoi River near Mansonville, Que. Tenders to be opened at the council room in Potton, on May 5th. Plans and specifications prepared by the Quebec Government may be seen at the office at Mansonville of J. N. Labell, Secy.-Treas.

Simcoe, Ont.—Tenders addressed to Dominion Cannery, Ltd., Simcoe, Ont., will be received until May 6, 1913, for low pressure vacuum steam heating system (Webster Specialties) for building at Simcoe, 77 x 296 ft., basement and three storeys. Building now ready. Plans and specifications can be seen at Darling Bros., 77 York Street, Toronto, Ont., or in Simcoe.

Guelph, Ont.—Tenders will be received up to April 26th by board of works and sewer commissioners for: (1) steel foot bridge, consisting of two 97-ft. deck spans, one through truss at 100 ft. and 6 I-beam approach spans; (2) construction of concrete substructure for the above; (3) alternative tenders for a reinforced concrete bridge on same site. Plans, etc., from city engineer.

Montreal, Que.—Four tenders were received by the Board of Control Saturday for the construction of the underground conduits along St. Catherine Street. The tenderers are the Hickey Contracting Company, G. M. Gest, the Standard Construction Company and Quinlan and Robertson. Each of the contractors deposited a cheque for \$15,000. The estimated cost of the work is \$200,000.

Trade Gossip

James Eadie, a graduate of Glasgow University, has been appointed Clerk of

Works for the new Technical School, Toronto, which is being built, at a salary of \$1,800.

The Chicago Pneumatic Tool Co. advise us that the matter of erecting a plant in Canada is at present being held in abeyance pending the return of the president who is now abroad. Until his return, nothing will be done.

J. F. Whitson, who is in charge of the Ontario Road Construction Branch, left last week for Cochrane, Ont., where he will oversee the preliminary plans for the road-building that is to be done in that part of Northern Ontario during the coming summer.

Frank Murphy, of Hespeler, Ont., who has been a foreman in the Car and Coach Company's works at Preston for some years, severed his connection with that firm on Saturday, April 19. He will leave shortly for Tillsonburg, where he will enter the new car works firm which is being started in that town. Before leaving the works in Preston on Saturday, he was presented with a lengthy address, accompanied by a fine suit case and a gold watch fob.

W. D. Beath & Son, Toronto, recently supplied The Canadian Bag Co., of Montreal, with an electric hoist and trolley system. The capacity is one-ton and there will be five three-way switches, and five two-way switches, and over 1,000 feet of 8-inch I beams will be used. They have also received contracts for a two-ton electric runway, electric hoist trolley system for the Orphen Conduit Co., and are also installing a three-quarter ton runway system for Batts, Ltd., Pacific Ave., Toronto.

Personal

Charles Jones, superintendent of the St. Thomas Electric Railway, will in all probability succeed J. W. Young, as superintendent of the London line.

J. W. McDonald, son of the late Robt. McDonald, of Enderby, B.C., has taken over the blacksmith and machine-shop business of Wm. Hutehison.

W. J. E. Biker, has been transferred from Victoria, B.C., to Nelson, having been appointed engineer in the water branch of the provincial lands department.

W. Grant Morden, a member of the Richelieu and Ontario Navigation Co. Board, has been elected a director of the Collingwood Shipbuilding Company, of Collingwood, Ont.

City Engineer Ashplant, of London, Ont., has submitted a scheme to the council for the re-organization of the

Engineers' Department, suggesting that an outside man be engaged for the department of works. Mr. Ashplant is in favor of appointing a man for sewer maintenance, street cleaning, street oiling, sprinkling, garbage collecting, street repairs.

Burton Stewart, general manager for Norton Griffiths & Co., left last week for London, Eng., where he will confer with the officers of the company regarding Canadian plans. Work is going on quite satisfactorily on the St. John harbor scheme. He said it is probable that a Canadian board of directors will be appointed to handle the affairs of the company in this country.

Chief Engineer Bowden, of the Department of Railways and Canals, and Engineer Weller, who is in charge of the New Welland Canal construction, have returned from a trip to the Panama Canal zone. They went there for the purpose of studying the methods of construction followed in digging the Panama Canal with a view to the adoption of such features as they may consider useful in the building of the new Welland.

R. S. Hart, who has been promoted from the position of accountant at the Welland plant of the Canadian Steel Foundries to the chief accountant of the company, and who left on Wednesday, April 23, for Montreal, where he will be engaged, was banqueted at the Arlington on the previous Friday night by members of the office staff and foremen of the different parts of the foundry. Dr. McBride, A. H. M. Hay and T. Dillon were also present. After the supper had been partaken of W. R. Gilmore, works manager, on behalf of those assembled, presented Mr. Hart with a gold watch, chain and fob. He accompanied the presentation with a short address in which he expressed regret that Mr. Hart was leaving, and referred to the improved conditions which he had brought about at the plant, now one of the best paying that the company has.



NOVA SCOTIA STEEL & COAL CO.

A MARKED improvement has been noted of late in the United States iron market, according to Mr. Thomas Cantley, general manager of the Nova Scotia Steel and Coal Co., and the sales of iron ore will show a decided increase during the present year. In 1912 the company mined at Wabana, Newfoundland, no less than 555,000 tons. Current selling prices show a considerable improvement over last year, and the earnings will naturally be largely augmented as a result.

SELECTED MARKET QUOTATIONS

Being a record of prices current on raw and finished material entering into the manufacture of mechanical and general engineering products.

FIG IRON.

	Per Ton.	
Foundry No. 1 and 2, f.o.b., Midland	\$19 00	\$19 50
Gray Forge, Pittsburg	16	15
Lake Superior, charcoal, Chicago	18	00
	Mont'l.	Tor'to.
Canadian f'dry, No. 1..	\$21 00	\$20 00
Canadian f'dry, No. 2..	20 50	19 50
Middlesboro, No. 3....	23 50	23 50
Summerlee, No. 2	25 00	26 50
Carron, special	25 00
Carron, soft	25 00
Cleveland, No. 1	24 25	25 00
Clarence, No. 3	23 75	24 50
Jarrow	25	50
Glengarnock	26	00
Radnor, charcoal iron.	30 00	34 50
Ferro Nickel pig iron (Soo)	25	00

BILLETS.

	Per Gross Ton.	
Bessemer billets, Pittsburgh ...	\$28 50	
Open hearth billets, Pittsburgh.	29 00	
Forging billets, Pittsburgh.....	36 00	
Wire rods, Pittsburgh	30 00	

FINISHED IRON AND STEEL.

Per pound to large buyers:

	Cents.
Common bar iron, f.o.b., Toronto..	2.10
Steel bars, f.o.b., Toronto.....	2.20
Common bar iron, f.o.b., Montreal.	2.15
Steel bars, f.o.b., Montreal.....	2.25
Bessemer rails, heavy, at mill....	1.25
Iron bars, Pittsburgh	1.70
Steel bars, Pittsburgh, future	1.40
Tank plates, Pittsburgh, future...	1.45
Beams, Pittsburgh, future	1.45
Angles, Pittsburgh, future	1.45
Steel hoops, Pittsburgh	1.60

Toronto Warehouse f.o.b., Toronto.

	Cents.
Steel bars	2.30
Small shapes	2.40
Warehouse import, freight and duty to pay:	Cents
Steel bars	1.95
Structural shapes	2.05
Plates	2.05
Freight, Pittsburgh to Toronto:	
18 cents carload; 21 cents less carload.	

BOILER PLATES.

	Mont'l.	Tor'to.
Plates, ¼ to ½-in., 100 lbs.	\$2.35	\$2.35
Heads, per 100 lbs.....	2.65	2.95
Tank plates, 3-16 in.	2.60	2.60
Tubes, per 100 ft., 1 inch	9.00	8.50
" " 1¼ in.	9.00	8.50
" " 1½ "	9.00	9.00
" " 1¾ "	9.00	9.00
" " 2 "	8.75	8.75
" " 2½ "	11.50	11.50
" " 3 "	12.00	12.00
" " 3¼ "	13.75	13.75
" " 3½ "	15.00	15.00
" " 4 "	18.00	18.00

BOLTS, NUTS AND SOREWS.

	Per cent.
Stove bolts	80 & 7½
Machine bolts, ¾ and less	65 & 5
Machine bolts, 7-16.....	57½
Blank bolts	57½
Bolt ends	57½
Machine screws, iron, brass	35 p c
Nuts, square, all sizes.....	4c per lb off
Nuts, Hexagon, all sizes...	4¼ per lb off
Flat and round head.....	35 per cent.
Fillister head	25 per cent.
Iron rivets	60, 10, -0 off
Wood screws, flathead, bright	85, 10 p c off
Wood screws, flathead, brass	75, 10 p c off
Wood screws, flathead bronze	70, 10 p c off

National-Acme "Milled Products."

Sq. & Hex Head Cap Screws	65 & 10%
Sq. & Hex Head Cay Screws	65 & 10%
Rd. & Fil. Head Cap Screws	45-10-10%
Flat & But. Head Cap Screws	40-10-10%
Finished Nuts up to 1 in. ..	75%
Finished Nuts over 1 in. ..	72%
Semi-Fin. Nuts, up to 1 in...	75%
Semi-Fin. Nuts over 1 in....	72%
Studs.....	65%
Discounts f.o.b., Montreal.	

WROUGHT IRON PIPE.

The following are Toronto jobbers' discounts on pipe in effect from April 21, 1913:

	Standard	Buttweld Black	Gal.	Lapweld Black	Gal.
¼ ¾ in.	62	47	
½ in.	68	58	
¾ to 1½	71½	61½	68½	58½	
2 in.	71½	61½	68½	58½	
2½ to 4 in. ..	71½	61½	70½	60½	
4½ to 6 in.	71½	61½	
7, 8, 10 in.	66	54	

X Strong P. E.

¼, ¾, 1½ in. ..	56½	46½
¾ to 1½ in. ...	67½	57½
2 to 3 in.	68½	58½
2½ to 4 in.	65	55
4½ to 6 in.	64	56
7 to 8 in.	55	45

XX Strong P. E.

½ to 2 in.	43	33
2½ to 4 in.	43	33

PRICES OF WROUGHT IRON PIPE.

Standard. Nom. Diam.	Price. per ft.	Extra Strong. Sizes Ins.	Price per ft.	D. Ex. Strong. Size Ins.	Price per ft.
½ in	\$.05½	½ in	\$.12	½ in	\$.32
¾ in	.06	¾ in	.07½	¾ in	.35
1 in	.06	1 in	.07½	1 in	.37
1¼ in	.08½	1¼ in	.11	1¼ in	.52½
1½ in	.11½	1½ in	.15	1½ in	.65
2 in	.17½	2 in	.22	2 in	.91
2½ in	.23½	2½ in	.30	2½ in	1.37
3 in	.27½	3 in	.36½	3 in	1.86
3½ in	.37	3½ in	.50½	3½ in	2.30
4 in	.58½	4 in	.77	4 in	2.76
4½ in	.76½	4½ in	1.03	4½ in	3.26
5 in	.92	5 in	1.25	5 in	3.86
5½ in	1.09	5½ in	1.50	5½ in	5.32
6 in	1.27	6 in	1.80	6 in	6.35
6½ in	1.48	6½ in	2.08	6½ in	7.25
7 in	1.92	7 in	2.86	7 in
8 in	2.38	8 in	3.81	8 in
9 in	2.50	9 in	4.34	9 in
10 in	2.88	10 in	4.90	10 in
10 in	3.45	10 in	5.48	10 in
10 in	3.20
10 in	3.50
10 in	4.12

IRON PIPE FITTINGS.

Canadian malleable, 40 per cent.; cast iron, 65; standard bushings, 70; headers, 60; flanged unions, 65; malleable bushings, 65; nipples, 75; malleable, lipped unions, 65.

COKE AND COAL.

Solvay Furnace Coke	\$5.25
Solvay Foundry Coke	6.50
Connellsville Furnace Coke	5.25
Connellsville Foundry Coke	5.75
Yough, Steam Lump Coal	3.83
Penn. Steam Lump Coal	3.63
Best Slack	2.95
All net ton f.o.b. Toronto.	

OLD MATERIAL.

	Tor'to.	Mont'l.
Copper, light	\$12 05	\$11 00
Copper, crucible	15 00	13 50
Copper, unere'bled, heavy	13 05	12 50
Copper wire, unere'bled..	13 05	12 50
No. 1 machine compos'n..	12 00	11 00
No. 1 comps'n turnings..	10 00	10 00
New brass clippings	9 15	9 10
No. 1 brass turnings	8 30	7 75
Heavy lead	3 25	3 25
Tea lead	3 00	2 75
Scrap zinc	4 00	3 75
Dealers' purchasing prices.		

METALS.

Prices in cents per pound:

	Mont'l.	Tor'to.
Lake copper	16.25	16.25
Electrolytic copper	16.25	16.25
Spelter	6.00	6.10
Lead	4.70	5.50
Tin	52.00	52.00
Antimony	10.00	9.75
Aluminum	23.00	21.00

SMOOTH STEEL WIRE.

No. 6-9 gauge, \$2.35 base; No. 10 gauge, 6c extra; No. 11 gauge, 12 extra;

No. 12 gauge, 20c extra; No. 13 gauge, 30c extra; No. 14 gauge, 40c extra; No. 15 gauge, 55c extra; No. 16 gauge, 70c extra. Add 60c for coppering and \$2 for tinning.

Extra net per 100 lb.—Spring wire; bright soft drawn, 15c; charcoal (extra quality), \$1.25.

SHEETS.

	Mont'l.	Tor'to.
Sheets, black, No. 28....	\$2 85	\$3 00
Canada plates, ordinary,		
52 sheets	2 80	3 00
Canada plates, all bright.	3 70	4 15
Apollo brand, 10¾ oz.		
(American)	4 30	4 20
Queen's Head, 28 B.W.G..	4 50
Fleur-de-Lis, 28 B.W.G..	4 20
Gorbal's Best Best, No. 28	4 45
Viking Metal, No. 28....	4 40

NAILS AND SPIKES.

Standard steel wire nails,		
base	\$2 40	
Cut nails	\$2 60	2 65
Miscellaneous wire nails..	75 per cent.	
Pressed spikes, 5/8 diam.,		
100 lbs.	2 85

FINE STEEL WIRE.

Discount 25 per cent. List of extras. In 100-lb. lots: No. 17, \$5; No. 18, \$5.50; No. 19, \$6; No. 20, \$6.65; No. 21, \$7; No. 22, \$7.30; No. 23, \$7.65; No. 24, \$8; No. 25, \$9; No. 26, \$9.50; No. 27, \$10; No. 28, \$11; No. 29, \$12; No. 30, \$13; No. 31, \$14; No. 32, \$15; No. 33, \$16; No. 34, \$17. Extras net. Tinned wire, Nos. 17-25, \$2; Nos. 26-31, \$4; Nos. 30-34, \$6. Coppered, 75c; oiling, 10c.

MISCELLANEOUS.

	Cents
Putty, 100 lb drums	\$2.70
Red dry lead, 560 lb. casks, per	
cwt.	6.00
Glue, French medal, per lb	0.10
Glue, 100 flake	0.11
Tarred slaters' paper, per roll...	0.95
Motor gasoline, single bbls., gal..	24½
Benzine, per gal.	23½
Pure turpentine	64
Linseed oil, raw	58
Linseed oil, boiled	61
Plaster of Paris, per bbl.	2.10
Plumbers' Oakum, per 100 lbs....	3.25
Pure Manila rope	17

The General Market Conditions and Tendencies

This section sets forth the views and observations of men qualified to judge the outlook and with whom we are in close touch through provincial correspondents.

Montreal, April 28.—This is moving week and many firms have made it a blank because of "flitting." However, the tone of the machinery market has steadily stiffened and this week shows splendid sales according to the large machine tool brokers. The story of the equipment of the Transeona Shops and the C.P.R. Western lines is still hanging fire but most of the big jobbers are dissipating their minds of any concern regarding these railway sales and are settling down to normal competition. Everything points to bigger sales daily now. Navigation is open and shipping is in full swing so that orders will receive the benefit of immediate attention by lake and ocean.

"We are very busy" was the answer to "How are things?" all along the line and stepping over to manufacturers one finds that they are now feeling like buying new stuff when a month ago they hesitated. Money is loosening and that's the answer.

Pig Iron & Copper.

Pig iron prices have softened and the opening of navigation is the factor in that movement. From American points came reports of cuts, etc., especially

from Pittsburg. Dulness again characterized a featureless market. Producers are reported to be pessimistic at the prices prevailing and are threatening, among themselves, of course, to curtail output at existing prices. There is no apprehension on the part of either producers or brokers for the future.

The copper market remains quiet, but some reports say an advance and others say decline. Our prices remain the same though we were authorized to quote from one house twenty-five cents less or \$16 instead of \$16.25 last week. That Europe is overburdened with American shipments is the general view here, hence quietness.

The tin market is steady and the half cent advance of last week is well maintained. It is thought that much of the buying of last week's record was for speculative purposes, and because tin looked cheap when based on the prices of London, England.

In pig lead a report was current that a drop had taken place to-day of five cents. This was contradicted because in some markets the advance has been steady from day to day. Antimony and aluminum are both dull and uninterest-

ing. The hardware trade is unusually active and the shipping season always helps trade. River craft are laden with heavy cargoes of heavy and shelf hardware.

Bar iron is strong and active with no change in prices. There is a general stir all over the Eastern market and railway and builder's supplies are being ordered generally. Real estate is still active without any noise, but steadily improving under judicious curbing by the moneyed forces.

• • •

Toronto, Ont., April 30.—Reports regarding business and money this week are rather conflicting; some firms record an excellent week, while others find business rather slow. A prominent steel man in the city stated on Monday that he had not known such a quiet period for years as the last six days. Two very prominent features in the machinery market, however, give the situation a rather rosy appearance. The National Transcontinental Railway have made recommendations for machinery orders, which have not yet been made public; also, the Dominion Nickel Copper Co., of Sudbury, Ont., have placed a large order with at least one firm in the city for machine tool equipment to be used in their smelter. The bulk of the Nat. Trans. Rly. order for iron and wood-working machinery goes to Canadian manufacturers. These orders will be placed next week. The Michigan Cen-

tral Railway, as announced in Canadian Machinery some weeks ago, are building a machine shop at St. Thomas. They have let the order for the building to The Arnold Co., engineers, of Chicago, who will also purchase the machinery equipment for this railway. Sheldon's, Ltd., of Galt, Ont., have placed an order for several moulding machines with The A. R. Williams Machinery Co. to be used in their new plant. The directors of the Toronto Technical School are also in the market for machine tool equipment to be used in the new edifice they are erecting. The Sydenham Glass Co., of Wallaceburg, Ont., have been buying machine tools during the past week for their new plant at Redcliff, Alta. This order has gone to the Canada Machinery Corporation, Bertram's, Ltd., and the A. R. Williams Machinery Co. On the whole the machinery market looks well, although money is reported to be still a little slow.

Pig Iron and Steel.

The pig iron market is very quiet and prices remain the same. There has been no English pig iron sold in this part of the country this year, and conditions are unchanged. Constructional men are going ahead with their larger jobs, and the smaller ones will follow the lead. Jobs that have been held for over three months are now securing steel. Everybody is buying on specification and for immediate needs only. That is, a builder buys steel only when knowing where he is going to place it, not taking any chances about future developments. There has been quite a brisk business in waterworks supplies during the week, particularly in valves and hydrants. This is the time of the year when municipalities do considerable repair work in this line.

Coke and Coal.

The market is very firm, and during the summer, slack will be easier for spot delivery contracts. There are no changes in coke prices, and the market is in a healthy condition.

Metals.

There is very little to report in this market this week, as business is very quiet, and prices remain almost the same. Tin took a jump of half a cent a pound, and copper is stationary.



MUNICIPAL NEWS OF MONTREAL.

THE Board of Control have recently called tenders for the new underground conduits for electric wires on St. Catherine's Street, one of the leading thoroughfares of Montreal. The tenderers are: The Hickey Contracting Company, Mr. G. M. Gest, The Standard Construction Company, and Quinlan & Robertson. Each tender was accompanied by accepted cheque for \$15,000. The tenders were referred to the Electric Service Commission for a report. They will be then sent to the City Council. The work will cost about \$200,000.

POSITION WANTED

POSITION WANTED—SUPERINTENDENT or general foreman by master mechanic with high technical training and broad, practical experience in economical production methods; foundry, machine shop, press work, tool and die work; have originality and initiative ability; experience in handling men is varied and extensive. Box 130, Canadian Machinery. (15)

PATENTS
PIGEON, PIGEON & DAVIS

71A, ST. JAMES STREET, MONTREAL
Phone, Main 3025

TRADE MARKS, COPYRIGHTS & DESIGNS
PATENTS
LLOYD BLACKMORE & COMPANY
LUMSDEN BUILDING, TORONTO.
ALSO, HOPE BLDG. OTTAWA & WASHINGTON, D.C.
We have an interesting and valuable booklet "PATENT PROTECTION" which will be sent free upon request.

Classified Advertisements

¶ Those who wish to sell or buy a business, obtain competent help, connect with satisfactory positions, or secure aid in starting new enterprises should not fail to use the Waut Ad. Page of "CANADIAN MACHINERY."

¶ If you want to sell or buy a second-hand lathe, planer or any other shop equipment, let "CANADIAN MACHINERY" pick out a seller or buyer for you. How about that second-hand engine or boiler which you would like to dispose of?

¶ "CANADIAN MACHINERY" is the central market place of the machinery trades throughout Canada.

¶ There is always some one looking for just such proposition as you have to offer.

Rates (payable in advance):—2c per word first insertion, 1c per word subsequent insertion, 5c additional each insertion when Box Number is required. Each figure counts as one word.

MACHINERY FOR SALE

MACHINERY FOR SALE—NEW AND SECOND-HAND machinery, engines, boilers, wood and iron working machinery and supplies. Write, stating what you require. Prompt and careful attention to all inquiries. The Advance Machine Works Co., Montreal, Que.

FOR SALE—A JOHN BARNES NO. 4 1/2 FOOT power lathe; screw cutting; steady rest; full set of gears; two face plates; takes 25 in. between centres; in new condition. Suitable for amateurs or a small jobbing shop. Apply Box 125, Canadian Machinery, Toronto.

Morton Manufacturing Co.
Draw Cut Shapers, Special Draw Cut R. R. Shapers, Special Locomotive Cylinder Planers, Portable Planers, Stationary & Portable Key Way Cutters, Finished Machine Keys.
Office & Works, Muskegon Heights, U.S.A.

PATTERNS
WOOD AND METAL
Allow us to estimate. Satisfactory work guaranteed.
TAYLOR PATTERN WORKS WALKERVILLE, ONT.

STEEL CASTINGS
Of the Highest Prevalent Quality
We make perfect castings at a price that is right.
NEW PROCESS CONVERTER STEEL CASTINGS, annealed and unannealed.
We also make **CHROME-MANGANESE AND NICKEL STEEL CASTINGS.**
Any size from quarter lb. to 30,000 lbs., absolutely guaranteed.
GET OUR ESTIMATES.
JOLIETTE STEEL CASTING WORKS, Ltd.
Head Office and Foundry: **JOLIETTE, P.Q.**

Casting for a 10,500 H.P. Water Wheel

Description of Core Oven Equipment for a Large Foundry

By George Laidler

An illustrated article giving details in connection with the construction and operation of a set of core ovens, embodying some unusual features, which were recently installed at the plant of a large Ontario firm of engineers.

SOME time ago, one of our large Ontario engineering firms made an extension to its foundry building which greatly increased the productive capacity. As a result, new core ovens became necessary, the old ovens being no longer suitable either in size or location.

Figures 1, 2 and 3 show general views of this particular portion of the foundry. The large ovens are located against an outer wall near the centre of the building. Owing to lack of room outside, the firing pit is placed between the ovens and is arranged for firing either with coke or oil fuel. The roof of the oven is used as a floor. It bridges the firing pit and extends about 15 feet beyond the large oven, the outer end being supported by steel columns. This floor affords space for core storage racks and a long reel type oven for small cores; all within a convenient distance of the core-makers' benches. These benches stand on a light wooden floor, carried on wooden joists and posts, and running as a continuation of the storage floor to the end of the building. Communication with the ground floor of the foundry is had by a flight of iron stairs over the furnaces at the front of the firing pit, and also by a 6 ft. x 5 ft. hand power elevator of 1,000 pounds capacity situated near the furnace end of the core-maker's floor, and close by the doorway to the sand-mixing shed.

The oven tracks run out beyond the side columns into the centre bay of the building, giving room for two trucks outside each oven. This allows service from the cranes in the centre bay and also from a small jib crane which travels

on a runway attached to the side columns. With the help of a crane, the core oven trucks may be drawn into or out of the ovens by means of blocks anchored at the inner and outer ends of the tracks. The core trucks are made up of heavy steel framework mounted on axles with roller bearings. A removable super-structure of channel irons

terminates and rest on piers, one to each pair of tracks. The steel columns at the end of the core storage floor stand on a cantilever concrete beam, which is carried by a single pier at the point of balance. As the column loads are roughly in the ratio of 2 to 1, the point of support is about one-third the length from one end.

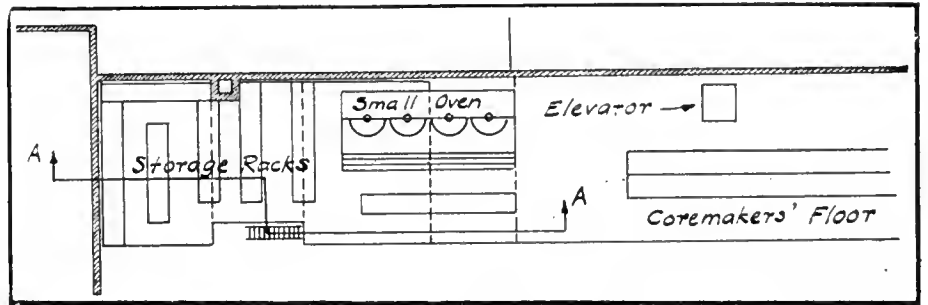

FIG. 1.—PLAN OF STORAGE FLOOR.

and old rails can be adapted to carry various sizes and shapes of cores.

Foundations.

Figures 4 and 5 show constructional details. The foundations are of special interest, as the whole of the foundry extension is over what was formerly an inlet from Lake Ontario. The walls of the building had been built of beams of reinforced concrete resting on simplex concrete piles 13 inches diameter and about 8 feet apart, as shown on the left of the figures; and the columns on a concrete capping of pyramid form on top of a cluster of four such piles. On commencing excavation for the ovens the subsoil of the old fill was found to be quite unsafe, so the original scheme of spread footings under the oven walls was abandoned in favor of a framework of concrete beams. These beams were constructed on top of piers which ran down about 18 feet to firm ground, and were suitably reinforced with twisted rods. Two piers of section 2 feet by 3 (the smallest size convenient for hand excavation) were put in under each long wall beam at about one-fifth the length from one end, the continuous beam being practically uniformly loaded. These piers were cheaply and quickly made, two laborers taking one day to excavate each. The body of the pier was made up of lumps of old concrete. The tracks outside the ovens lie on heavy concrete beams, which are bridged near the ex-

Core Storage.

The storage floor over ovens and firing pit is designed for a dead load of 200 pounds per square foot. It consists of a 5-inch concrete slab reinforced with deformed bars $\frac{5}{8}$ -inch diameter spaced at 12-inch centres, resting on concrete beams of suitable depths, and which are reinforced with Kahn bars. Slab and beams rest on walls of common red brick 13 inches thick. At the end near the coremakers' floor, the slab is reduced to a thickness of 3 inches, reinforced with expanded metal sheets and carried on a framework of steel beams. Where the storage racks occur,

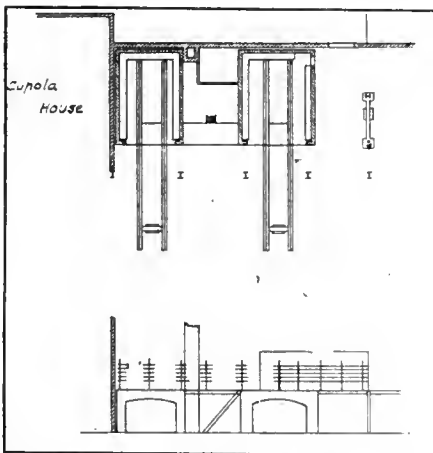

FIG. 2.—FLOOR PLAN OF OVENS.
FIG. 3.—ELEVATION OF OVENS.

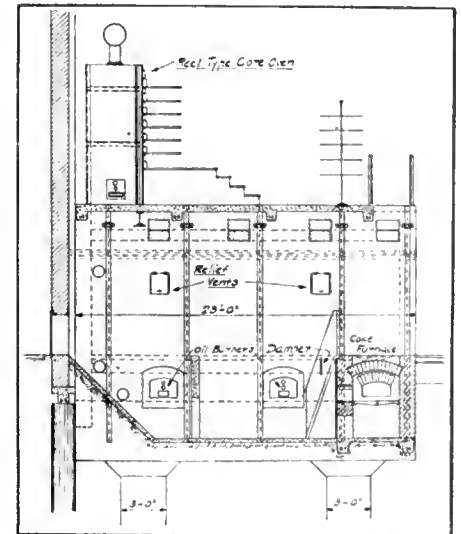

FIG. 4.—SECTION THROUGH FIRING PIT.

8-inch channels are embedded in the slabs for the full length of the ovens, over walls wherever possible. This distributes the load on the slab and enables easy connection to the flanges of the pipe standards to be made. Under the outer wall of the oven for small cores, the loading is very heavy, and additional steel beams are placed under the slabs. The racks for core storage consist of 1½-inch pipe uprights with flange bases, cast-iron arms clamped on, and sheet steel shelves stiffened with small angles.

Ovens.

The firm's experience in furnace construction having shown that, although concrete exposed to heat may stand well

walls at convenient intervals give access to the top of the arch should repairs ever be necessary.

Firing Arrangements.

At the front of the firing pit are located the furnaces intended for coke, one for each oven. The hot gases can pass directly from the furnace into the hot air trough under the core trucks, or they may be diverted by a damper to the smoke stack by way of a flue along by the side wall. This flue also carries a damper at some distance from the furnace. A small firebrick arch at the front of the hot air trough directs the heat towards the back of the oven through cast iron gratings which span the trough. At the back of the firing pit

side walls to relieve any explosion that might occur. Flues with dampers connect from top and bottom of the oven to the smoke stack and permit of some temperature regulation. Each oven has a recording thermometer mounted in the front wall. At the front of the ovens are folding doors of sheet metal braced with angle irons and lined with thick asbestos for better heat insulation. The larger oven has, in addition, a small side door near the rear. Racks are fitted along the oven walls to receive small cores.

Oven for Small Cores.

On the top of the main ovens stands the battery of reel type core ovens, in-

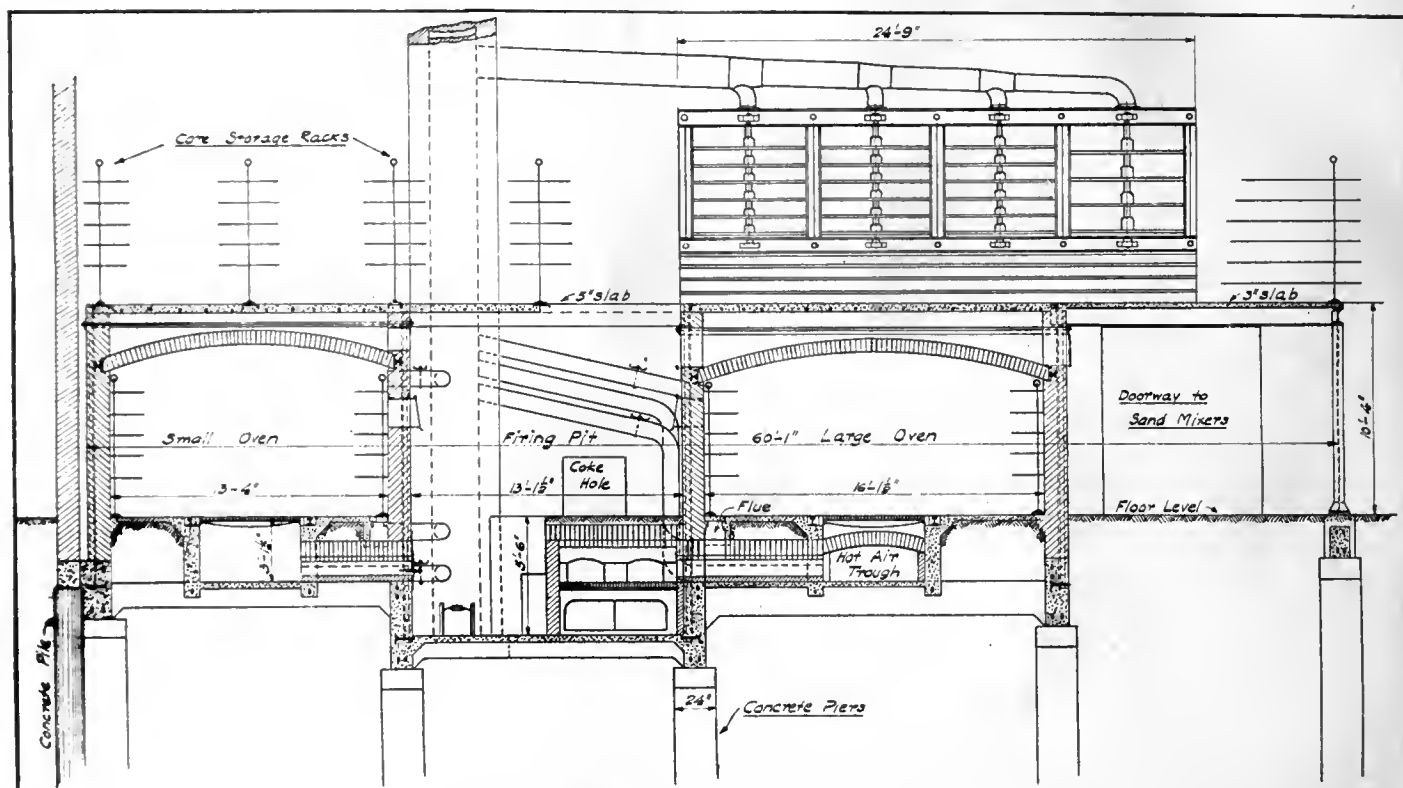

FIG. 5.—GENERAL SECTION ON AA OF FIG. 1.

for some time, it is liable in the long run to become cracked and disintegrated, decided them to protect the roof of the ovens by an arch of firebrick, one brick thick. This was carefully made and well luted with fireclay. As the temperature stresses are not excessive and the arch merely carries its own weight, it was given the small rise of about one inch per foot of span. The side thrust for so flat an arch becomes considerable, and is taken by steel beams embedded in the walls. These in turn bear against old rail brick stoves, which are firmly anchored to the concrete foundations at the lower ends and bound together above the crown of the arch by tie rods and bridge plates. Manholes in the side

a bin is provided to hold coke for this furnace.

The oil burners are fitted on iron plates at the mouths of two tunnels in the side wall, which open into the hot air trough. With steam at a pressure of 60 pounds per square inch an oil at 50 pounds, a temperature of 700 degs. Fahrenheit can be maintained, although the ordinary working temperature ranges between 400 degs. and 500 degs. Of the two methods of firing, that of oil fuel through the side wall burners is the one commonly used on account of its better efficiency, cleanliness and ease of regulation. The coke furnaces are intended as a standby. Automatic vents with sheet metal doors are fitted in the

tended solely for small cores. The oven has four reels, each revolving independently in its own ball bearings and permitting of any convenient length of baking time. As the reels are half in the oven and half out, with a sealing division between, they serve as racks, and continuous baking results without loss of time or heat. A self-supporting frame bound into the brickwork carries the cast iron reels, which are about five feet in diameter. This oven is fired from both ends with oil fuel. As the furnace stands above floor line, a platform is built in front of the ovens with a short flight of steps continuous along the outer edge.

The Production of Sound Steel Ingots by Compression

By Leslie E. Howard*

Some seven years ago, experiments were commenced by the Simonds Mfg. Co., Fitchburg, Mass., at their Chicago plant, with a view to developing a method for the production of sound ingots for saw manufacture especially, and the system and apparatus briefly described in the accompanying article is the outcome of this extended series of experiments.

THERE is probably no manufactured article made of steel in which the production of absolutely pipeless and sound ingots is of more importance than that of saws, and especially that line known as mill saws, which comprises not only the very large hand saws, but also the large circular and the auxiliary saws now in general use. When first suggested that the ingots commonly used in crucible steel mills be made sound by fluid compression, it was felt to be impracticable to develop a method and apparatus that would handle the very small ingots required, and it was found by investigation that practically no plants were in operation working on ingots of much less than a ton weight.

Having this in mind, the first experiments along the lines of method and pressing apparatus were on small experimental ingots weighing but 15 pounds each, and no difficulty whatever

heavier ingots, weighing around 110 pounds, and of rectangular cross section, $3\frac{1}{2}$ in. x $5\frac{1}{2}$ in. A pressing unit was then built capable of handling one 400 pound or two 200 pound ingots at each heat, and, with periodical modifications, this arrangement has been found very satisfactory, so much so that at the steel plant of the Simonds Mfg. Co., Lockport, N.Y., eight presses are now in continuous operation, making ingots ranging from 180 pounds up to and including 600 pounds in weight.

Deductions From Experiments.

It was found early in the series of experiments above referred to that it was quite out of the question to compress ingots in the same molds in which they had been poured, chiefly for the reason that the mold cost and up-keep was too great to make the proposition a commercial one. It was found that an in-

the process with a cross section of 4 in. x 8 in. and 8 in. x 12 in., and weighing respectively 350 and 600 pounds.

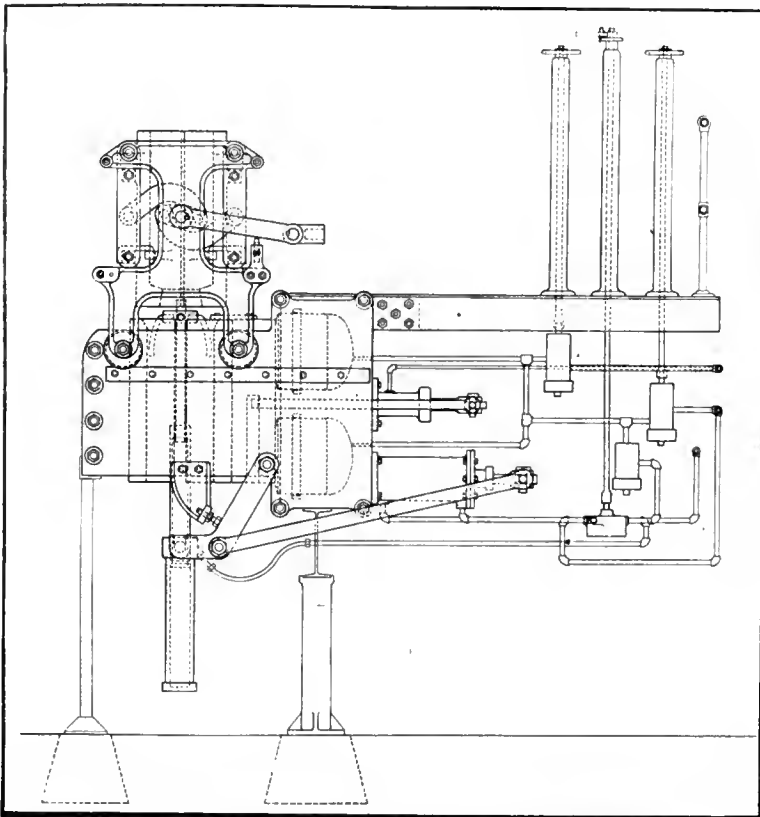

FIG. 1. GENERAL ARRANGEMENT OF MACHINE FOR COMPRESSING STEEL INGOTS.

was experienced in producing these absolutely sound, and without blowholes or pipes. The next step was on slightly

*Metallurgist, The Simonds Mfg. Co., Lockport, N.Y.

got of approximately square cross section could be operated on more satisfactorily than any other cross section (excepting round or octagon), although ingots have been made satisfactorily by

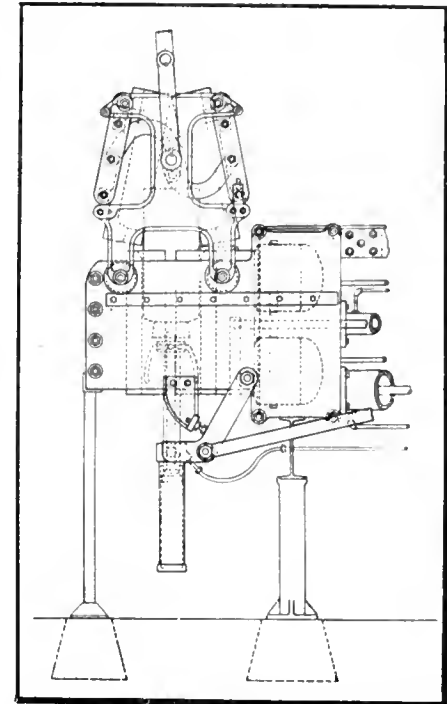

FIG. 2. VIEW OF PRESS SHOWING INGOT PARTLY LOWERED INTO THE DIES.

Another feature which the first investigations revealed was the fact that practically all attempts to compress ingots by lateral pressure previous to the method outlined here had been along the lines of placing a large number of molds "tandem" style in one pressing unit. A study of the effect of this arrangement showed conclusively that there is practically only one ingot in the series that could possibly receive proper treatment. Aside from this, most of the apparatus of this nature was rather cumbersome and expensive to operate, and the press had to be practically dismantled to get the ingots out after they had been operated on. It was, therefore, considered desirable to set to work on the lines of producing an apparatus possessing the following general features.

Features of the Apparatus.

First—To have the units small and extremely simple, so that if one unit was out of order for any reason it would not in any way affect the rest of the plant.

Second—To design these units so that the plant could be added to and the system extended at will, and, at the same

time, have each unit entirely separate and independent of the others, so that it could readily be lifted out of its place with a crane if out of order or damaged, and a spare unit put in its place. So far it has never been found necessary to do this, but it was considered desirable to have this in mind in developing the method.

Third—To be able to operate on the ingots in such a way that every individual ingot receives precisely the amount of pressure and time necessary to get the best results without reference to any of the other ingots being cast at the same time.

Fourth—To develop a system that would be so extremely simple and rugged that it would not require a different type of labor to operate than is commonly found in melting shops.

In addition to the above considerations, it is, of course, obvious that a plant of this nature to be commercially successful must not involve a large investment as compared with the returns, and that the operating costs must be extremely low.

Description of Process.

In a general way the method consists of casting the ingots in molds made of special cast iron, and, while the ingots are still internally fluid, but sufficiently set so that they will not burst by careful handling, they are transferred mechanically to steel compression dies, where they receive lateral or "side" compression of from $1\frac{1}{2}$ to 3 tons per square inch of greatest area of cross section operated on, this pressure depending largely on the composition of the steel, temperature of the steel when poured, etc. The line drawing, Fig. 1, shows the general arrangement of

presses for handling ingots up to $1\frac{1}{2}$ or 2 tons, and as small as may be desired, as many of these presses as are necessary for a given output being arranged side by side, supported in any suitable



FIGS. 5, 6. SECTIONS OF COMPRESSED AND UNCOMPRESSED STEEL INGOTS.

way, dependent on local conditions. An extension of the back end of the press serves as a support for a working platform, which is made continuous from press to press, this working platform on the small size presses being approximately 3 ft. wide; the length, of course, varying with the number of presses making up the installation. This is shown quite plainly in Fig. 3, which also gives

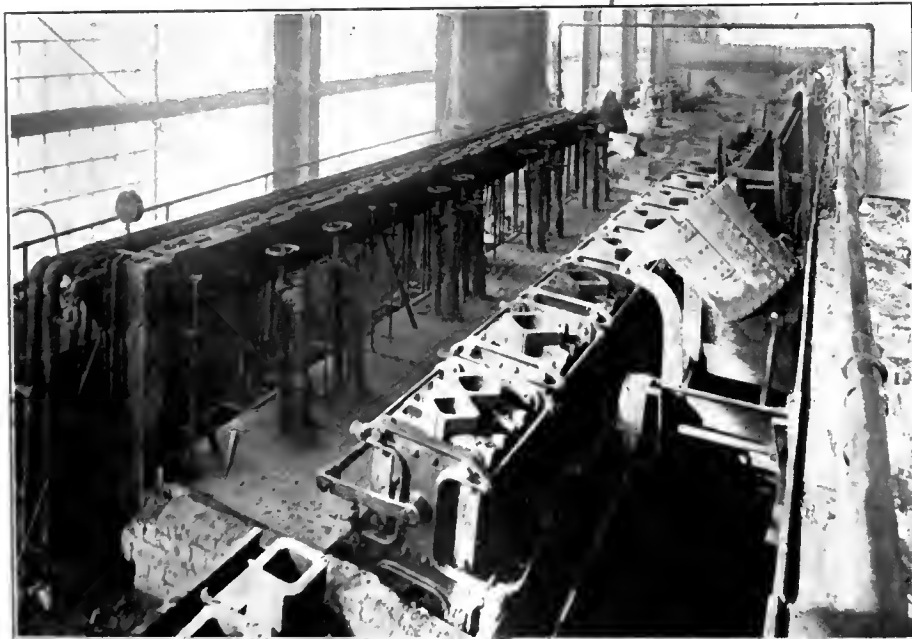

FIG. 3. PLATFORM FOR OPERATING MACHINES FOR COMPRESSING STEEL INGOTS IN THE PLANT OF THE SIMONDS MFG. CO., LOCKPORT, N.Y. THE RUNWAY FOR THE BUGGY LADLE IS SHOWN AT THE RIGHT.

a good idea of the valve control stands and the ingot racks.

It will be noticed in this view that press No. 1 in the foreground is equipped with one larger mold. A full equipment of both molds and dies are provided, however, for working all of the presses simultaneously on either size of ingots. Other odd sizes are provided for one or two presses, where the small tonnage does not warrant equipping eight presses with the special molds and dies. In ingots up to the sizes mentioned, and also up to and including 3,000 pounds, split molds are found satisfactory and desirable, as they greatly facilitate the stripping operation, and on account of the very short time which the ingots are in the molds, there is an entire absence of warping and distorting of the molds commonly met with in split molds, where the ingot is allowed to cool entirely in the molds to a point where it usually is stripped. Molds now in operation at Lockport, and which have been running eight months, night and day, are just beginning to show slight cracks in the side walls. They are, however, good for another six weeks or two months.

Press Features.

It will be noted by referring to Fig. 1 that the press proper is of a box-like form or design, this being found desirable on account of the great strength for the total weight of the completed press and for the low cost of machining, aside from making it very rugged and not easily damaged by rough handling. The hydraulic compressing cylinders form one end of the "box" and a heavy steel casting forms the other end, these two members being tied together by cast steel side stress members, interlocking joints being provided, so that the greater the strain between the back head and the rams the more closely do the side members pull in on the cylinders and back head. The tie rods holding all of the press members together have, therefore, only to keep the members in place when there is no load on the rams or when handling the units. A simple retracting arrangement for the cross head and hydraulic rams is provided, which, in the case of the smaller size units, is usually a spiral spring, and in the larger sizes is a hydraulic cylinder of very small cross section relative to the cross section of the pressing cylinders. It is piped to the high pressure supply without any provision being made for valves or control.

Ingot Lowering Mechanism.

The mechanism for lowering the partly cooled ingots from the molds into the compressing dies consists of a hydraulic cylinder and ram carried on two swinging arms (one on each side of the press), so that it may be brought out of vertical alignment with the dies when desired,

and leave the pit under the dies absolutely clear and unobstructed. The mechanism for accomplishing this result consists of a small low pressure cylinder usually mounted on the back end of the press, and provided with a simple cross arm and connecting rod arrangement controlling the movement of the swinging arms carrying the lowering ram

the cutting effect of the stream of molten steel when pouring, and they are practically the only parts that have to be renewed under seven or eight months. They ordinarily last when running night and day on one 30-pot furnace from two to three months. The regular procedure of operation on ingots with this apparatus is as follows:—

mined point. The molds are now poured by any approved pouring device, but at the plant described, a top-poured hydraulic operated ladle is used, as shown in the half-tone, Fig. 4. After pouring, the ingots are allowed to set a pre-determined length of time, depending on the size, composition of steel, etc., but in any event just as short a time as is necessary to form a light skin which will not burst open when the ingots are stripped. This time varies from one to five minutes on ingots, from 150 to 600 pounds in weight, and of various composition. The stripping mechanism is now operated, so that the molds occupy the position shown in Fig. 2 (which shows the ingot partly descended into the dies), leaving the ingot supported at the top end by the molds (which are not opened much, if any, at their top ends), and by the tapered block at the bottom end, which forms the bottom closure of the mold during the pouring.

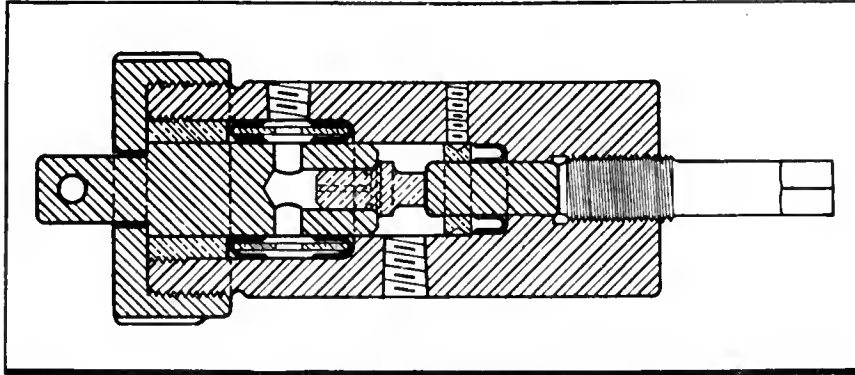

FIG. 7. CROSS SECTION OF HIGH PRESSURE HYDRAULIC VALVE.

cylinder noted above. The controlling valves and mechanism are extremely simple, all of the movements of the ingot after it leaves the mold being accomplished by one low pressure controlling valve, the handle of which being moved from notch to notch causes each of the parts to function properly and in their proper order. The high pressure cylinders are controlled by a simple form of stop valve and a simple one-way valve for discharge.

Mounted above the compressing dies is a mold carrying rack which needs very little explanation, as the drawing—Fig. 1 shows quite clearly the principle on which this works. The molds shown here are split. In the smaller sizes this mold-carrying rack is operated by hand, and in the larger sizes by a small hydraulic cylinder mounted on the side of the press frame; this is not shown on the drawing. Ingots of various cross sections have been operated on by the regular equipment, but the present molds and dies are designed and built for pressing the ingots corner-wise—that is, with one of their cross section diagonals at right angles and the other normal to the direction of compressing. Ingots of square cross section have been found to work out better, not only from the compression standpoint, but also for subsequent operations in the mills.

The bottom of the split mold referred to is formed partly by a removable round taper block carried on the lowering ram and so arranged that when the molds are “set up” this lowering ram is in its uppermost position and the taper block forms a “bottom closure” to prevent steel from running through the bottom of the mold. It is found that these blocks or mold bottoms take practically all the wear of the mold, such as

Procedure of Operation.

The molds (having been previously well smoked without removing from the racks) are locked together by the toggle arrangement shown in the drawings and the lowering plunger brought to its uppermost position, so that the bottom of the mold is closed by the taper block referred to. The controlling valve on the high pressure cylinder is, of course, closed and the discharge valve open, the dies being thus opened to a pre-deter-

Compressing Operation.

The low pressure controlling valve handle is now moved one notch, causing the ingot to descend into the compressing dies, the speed of this descent being controlled by a stop cock in the discharge line. The lowering cylinder is provided at its lower end with a spring, or in some cases with a hydraulic stop, so that the ingots are brought to rest very gently and in a position suitable for the pressing dies to operate on them. The high pressure release valve is now



FIG. 4. CASTING THE INGOTS FROM AN HYDRAULICALLY OPERATED TOP POUR LADLE.

closed, and the low pressure controlling valve handle moved on to the next notch; low pressure water is thus caused to flow from the low pressure supply through a high pressure check valve into the high pressure compressing cylinders, the compressing dies being thus rapidly moved up to and in contact with the ingots, while the cylinders are filled with water under low pressure, usually 100 to 125 pounds.

The high pressure controlling valve is next opened very slightly and compression is started. At this point the ingots are still fluid internally, and have not begun to show the slightest sign of pipe or "sinking" in the top end. The compressing cylinders are allowed to come up very slowly, so as to just keep the ingots from forming pipe, and this is continued until by experience it is known that the ingot is very near the point of setting or becoming solid throughout, when the pressure is increased slightly and a small amount of the last portion of the ingot to cool is squeezed out of the top, this, of course,

"rise"; in fact, after they have reached the point where they are considered solid, the pressure is quite materially increased. The ingots then receive what is virtually a hydraulic forging treatment, which tends to break up the coarse crystals formed in cooling into a fine crystalline structure, much resembling an ingot worked under a hammer or forging press.

The Ingot Product.

When the operation of compression is completed the high pressure control valve is closed and the discharge valve opened, after which the dies immediately retract and the ingots drop through into the pit. This latter may be provided either with a bottom of sand so that the ingots may be given a partial annealing before going to the stock piles, or the ingots may be dropped on to cars or a conveyor.

The resulting ingots have the appearance shown in Fig. 5, this being from a 400-pound ingot split longitudinally, while Fig. 6 is an ingot poured at the

unnecessary to change the molds and dies between the heats. The presses are amply provided with cooling facilities, so that the parts do not become overheated.

It is obvious that, with the hot ingots in contact with the mold walls, the latter do not get overheated, and no artificial cooling of any kind has been found necessary on the molds, the time being only 1-20 of that required when they are allowed to cool in the latter. The cross head and, on large presses, the compression dies are provided with water cooling, and the high pressure cylinders are also piped so that when they are not under actual load, low pressure cooling water may be circulated through them, thus keeping the rams and packing leathers at a reasonable temperature. No trouble whatever has been experienced with packing leathers, all of these having, on an average, run ten months night and day without renewal.

The pressure dies are of cast steel, and in the equipment described there are two grades—that is, one-half of the dies are .40 carbon, and the remainder .70 carbon steel castings, but up to the present time there is no appreciable difference in their performance, as neither of the dies show practically any signs of wear. They should last at least one year without replanning. The design has made allowance for at least seven or eight replanings, therefore 4 or 5 years should elapse before renewal.

Changing Moulds.

One point of special advantage in changing from one size ingot to another is the fact that there are absolutely no fastenings of any kind holding the molds or dies to the other mechanism, excepting that the molds are provided with loose links, which drop over one of the crossbars in the mold rack and can readily be lifted out by hand or by using a pair of tongs. The molds are usually lifted out of the rack with the crane in pairs, special hooks being provided for this, there being no more trouble to lift them out or in the mold racks than lifting them up from one position on the mill floor and setting them down in another. The compression dies are simply lifted in or out of the press frames, gravity alone keeping them in place. The retraction of the movable dies is accomplished by a loose fitting link, one end of which engages a pin in the top end of the movable die, the other end a pin in the top end of the cross head; this is readily lifted off and on with tongs or by hand.

The plant at Lockport is served by a single acting triplex, high pressure pump, with 1¼-in. rams of 8-in. stroke, driven by a 15 h.p. motor, and the low pressure supply is obtained by a 3½ x

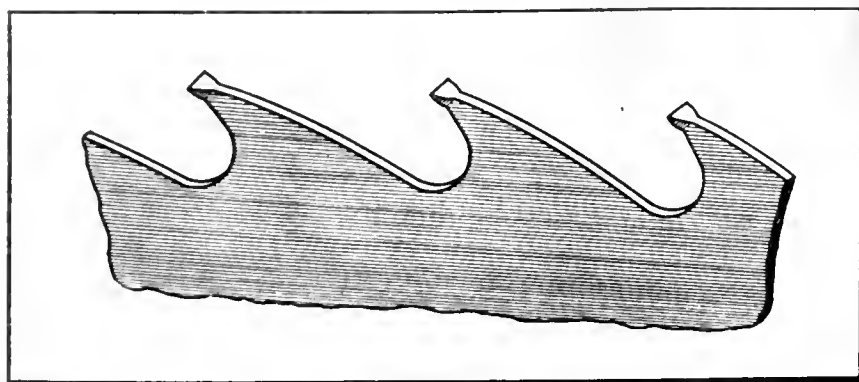

FIG. 8. SECTION OF A SHINGLE SAW.

being the liquated portion mentioned by A. Capron in his very able paper before the British Iron and Steel Institute of 1906. As pointed out by Mr. Capron and others, this liquated portion contains practically all the segregation and is decidedly higher in phosphorous, sulphur and other impurities. It forms a rough ball-like knob on the top end, and is practically the only portion of the ingot not suitable for finishing. Its weight varies from 2½ per cent. to 4 per cent. of the total weight of the ingot.

As soon as the compressing dies have a good grip on the ingots, so that there is no possible danger of their dropping through into the pit, the low pressure controlling valve handle is moved to the fourth notch, causing the low pressure cylinder to move the ingot lowering cylinder out of vertical alignment with the compressing dies, the controlling valve being then left in this position until compression is completed. The pressure is kept on the ingots for a considerable time after they have ceased to

same time, but weighing slightly less on account of its decreased length and not compressed. There is no dismantling of the presses to discharge the ingots, and the operation of setting up ready for another heat takes but a few minutes. In fact, the first of the presses to be poured are quite often set up—that is, the molds locked together and the low pressure valve handle moved to the first notch of its quadrant, thus causing the lowering ram to rise to its uppermost position and the taper block which it carries to close the bottom of the mold before the last of the series have dropped their ingots. The total operation of setting up eight presses occupies but 10 or 12 minutes, the greater part of which is used in smoking the molds. One man easily operates eight presses, and these are so designed that they may take care of from two to three furnaces (which in the plant described are 30-pot crucible furnaces), providing, of course, that all the furnaces are running on the same size of ingots, and it is, therefore,

4 triplex single acting pump running at 100 pounds pressure and driven by a 3 h.p. motor. As these pumps are only run about one half hour at each heat, it is obvious that the power consumption is extremely low. Both pumps have a common supply tank, and, of course, the discharge from the cylinders is piped back to this tank. This portion of the plant was so designed that, if found necessary during extremely cold weather, a solution of alcohol and water could be used to guard against freezing. So far this has not been found necessary, as the radiated heat from the adjacent furnaces has been sufficient to obviate any trouble in this direction.

All of the hydraulic valves on the high pressure side of this system are designed on the lines shown in Fig. 7, so that the valve and valve seats can be removed readily for repairs without breaking any pipe connections. The time for making a change on any of these valves practically never exceeds 30 seconds, and, on a test, has been done in 9 seconds. It has been found desirable to also equip the hydraulic pump, which operates at 4,500 pounds pressure, with valves of this general type, so that there is never any shut-down or stoppage on account of leaky valves.

Results Obtained.

Some of the results obtained from the use of this method are extremely interesting. Probably one of the most severe tests which could have been made was in the manufacture of shingle saws, which, as is well known, run in sizes from 36-in. to 42-in. diameter. They are from 9 to 7 gauge thick at the centre, and are ground "straight" for a collar or reinforcing plate, from which they taper to the rim until only of 14 or 16 gauge. These saws are left of just as high temper as possible to file them properly in fitting, and at the same time nearly all of them are "full swaged," as shown in Fig. 8, thus imposing a very severe test on the material even when the steel is absolutely sound and normal. While going through some tests on special steels, it was decided to determine how close these saws might be taken from the top of an ingot and still stand the severe swaging test. The results were very satisfactory, and several ingots were cut in such a way that one side of one saw from each ingot was only $\frac{3}{8}$ in. from the normal top line of the ingot. Every one went through perfectly sound, and were looked over by several inspectors, who could not by any test determine which saw came from the top of the ingot and which from the bottom. Later, field tests on these saws indicated that there was no difference whatever in the quality of the saw, whether made from the top or bottom portion of the ingot.

Another test which indicates the absolute soundness of the ingots made by this process was made on large band saws Fig. 9 shows what is known as a double cut band saw—that is, a band saw having teeth on both edges. These

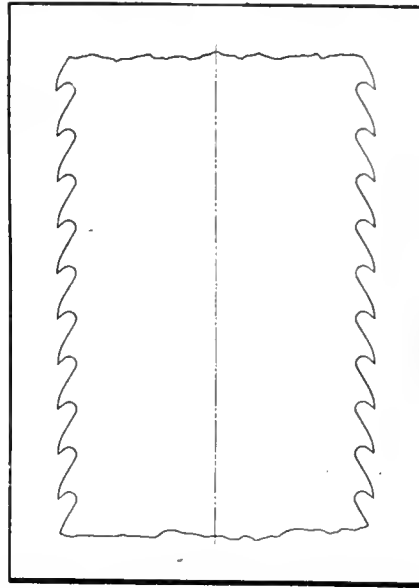

FIG. 9. SECTION OF A DOUBLE CUT BAND SAW.

also are full swaged, as shown in Fig. 8, and range in size from 6 in. x 16 gauge up to as large as 18 in. x 11 gauge thick. It is quite apparent that unsoundness of any kind would render the saw worthless. Several 12-in. saws were taken at random from our Chicago stock and on being split lengthwise from end to end and the "inside" edges toothed, they presented the appearance shown in Fig. 10. After being swaged, so that each tooth presented the appearance shown in Fig. 8, there was not a

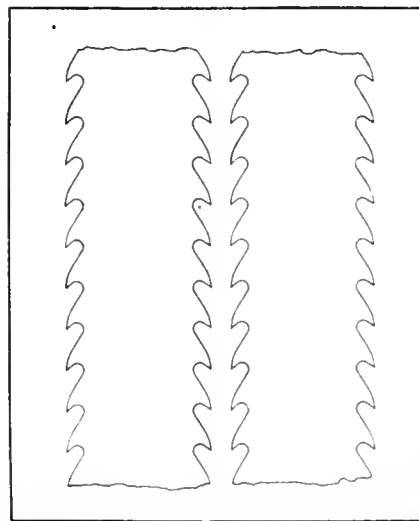

FIG. 10. DOUBLE CUT BAND SAW. SPLIT AND INSIDE EDGES TOOTHED.

single indication of split or pipe to be seen, proving conclusively that the steel must have been sound and free from pipes and blowholes from top to bottom of ingot, as these band saws are cut very

close to the top of the latter at the present time. Several ingots were cut longitudinally and the exposed surfaces planed and polished, after which a careful study of the structure was made. So far as these tests have gone, they show that the ingots were homogeneous and with an entire absence of segregation up to 600 pounds in weight, and that the structure of the steel as it leaves the compressing dies is absolutely uniform. Test pieces cut from these ingots without work of any kind being done on them have shown that steel taken from the top centre of the ingot, where the pipe usually forms, gives precisely the same physical tests as test pieces cut from other portions of the ingot, while in uncompressed ingots the centre of the ingot, even in the lower half and bottom end, does not test out nearly as well as pieces cut from the sides.

The Method Preventive.

In a general way the method is not intended to be a curative one, as tests made in the early experiments proved conclusively that if a pipe in an ingot had once developed, and sulphides and oxides formed on the surface of the cavity, it was practically impossible to weld it up or cure it in any way. The method is, however, preventive.

Various grades of steel have been operated on that may be made in a crucible or electric furnace, but practically all of the tonnage so far handled is tool steel used in the manufacture of saws and machine knives, this including straight carbon steels of the usual carbon content for the purpose noted, as well as low alloy steels. It has been found, however, that in the case of strictly high speed and semi-high speed steels, the apparatus must be handled very carefully, and the ingots at once annealed after pressing, this being owing to the increased density of the already very dense material due to compression. Great care must also be taken when re-heating ingots of this type that the heat is brought up slowly and uniformly to prevent the ingots bursting.

General.

The plant, as described, has been working night and day for something over a year, and at the present time all of the band saw and circular saw steel, excepting the very small circulars, is made from compressed material. Equipment is now in process of construction which will enable the Simonds Mfg. Co. to compress every pound of steel made in Loekport. It has been found that the total cost of running this plant is less than 3 per cent. of the value of the ingots operated on, and this will be reduced somewhat when the new equipment is completed, as a greater tonnage of ingots will be handled, with no in-

crease in labor cost and a decrease in capital charge, for the reason that interest and depreciation is now taken at 15 per cent. on not only the total cost of the plant as a going proposition, but also on all of the experimental work and expenses up to date.

Experiments are also under way for a modification of the device to be employed, especially on large ingots in which the split molds are replaced by the usual form of solid tapered mold handled by an ingot stripper of the standard design. The process and apparatus are covered by United States and foreign patents granted to Mr. L. E. Howard, of the Simonds Manufacturing Co.

CREOSOTE AND CROSS TIES.

By W. J. D.

ONE million, four hundred thousand gallons of creosote could have been produced in Western Canada in 1910 if the coal that was converted into coke had been coked in by-product ovens. With the exception of the creosote produced from the by-product ovens at Sydney, N.S. and at Sault Ste. Marie, Ont., no creosote is produced in Canada. This valuable wood preservative is imported from Britain and the United States, but the high cost of the imported article has restricted its use very materially. In view of the steady and even rapid rise in the price of almost all classes of wood products, the importance of creosote is readily seen.

For example, there is the problem confronting Canadian railways in obtaining timber for cross ties. There were 13,683,770 ties purchased in Canada in 1911, an increase of 48.5 per cent. over the figure for 1910. When it is considered that the annual replacement of ties on existing lines amounted to about 10,000,000, it is evident what enormous quantities of tie material are required in order to supply the demand. This demand will not remain stationary, but, on account of the increased mileage of railways being constructed in the Dominion, will increase each year.

Owing to the other demands for lumber and wood products, the price of cross-ties has been steadily increasing. The cost of tie maintenance is now a large item of expense, and the higher prices of the better grades of wood have forced the railway companies to use inferior wood. In 1908, cedar ties constituted 40 per cent, and jack pine (an inferior wood) 10 per cent. of the total used on Canadian railways. In 1911, the proportions were, cedar, 5.3 per cent. and jack pine 39.9 per cent.

In order that the lower grades of wood may be economically used for ties it will be necessary to creosote those species

that fail through decay. In order, also, to utilize ties of the softer woods, it is necessary to use tie-plates.

When it is remembered that the average life of an untreated tie is seven years, and the life of a treated tie is seventeen years, the importance and value of creosote is readily seen.

NOVA SCOTIA STEEL & COAL CO.

MR. Thomas Cantley, general manager of the Nova Scotia Steel and coal Co., in his annual report to the shareholders, gives a resume of the Company's operations:

During 1912, the coal tonnage mined totaled 841,000 tons, of which the company used 256,000 tons, sold in the Maritime Provinces 240,000 tons, and shipped to Montreal 330,000 tons. With the discovery of a new steam of high quality, the outlook was stated to be very favorable for a much larger tonnage in 1913. The average number of men on the payroll was 5,600, but this year's requirements will run largely in excess of this, as 1,500 men will be employed in the new mine. The wage bill last year was nearly \$3,250,000, the freight carried by the Sydney Mines Railway, the Company's road, was 1,600,000 tons; the amount paid to the Intercolonial Railway on freights was \$440,000, and the total tonnage carried by the Company's fleet exceeded one million tons, of which one-half was iron ore.

SAWMILL WRECKED.

AN explosion occurred at the sawmill at Stewarttown which completely wrecked the building. Four men were inside the mill at the time and Walter Lawson, the owner, had just left the boiler room less than a minute before the boiler exploded. William Bescohy was blown out of the building, but fortunately was uninjured. The saw operator was knocked down and slightly injured, and two other men were pinned down beneath some timbers, both, however, escaping practically unhurt. William Thompson, driving along the road, had pieces of the wreckage come perilously near to him, his rig being struck. A portion of the boiler, weighing half a ton, was carried three hundred yards. It is a miracle that no person was killed, as the building is a total wreck.

UNION OF GERMAN MACHINE TOOL MANUFACTURERS.

A REPORT just issued by the Union of German Machine Tool Manufacturers states that in view of the increasing productive capacity of German ma-

chine tool makers, larger foreign outlets are considered absolutely necessary, and every endeavor is to be made to induce the Government to frame the new commercial treaties on lines which will assist the machine tool industry in its attempts to extend its hold on the export trade. The total number of workpeople employed in the manufacture of machine tools in Germany is over 80,000, with 7,000 officials in addition, while the total annual output is given as 225,000 tons, valued at \$53,350,000.

CANADA IRON CORPORATION.

THE Canada Iron Corporation have had a considerably better ten-month period from June 1, 1912, to April 30, of this year, than the corresponding ten-month period a year before. The output of the mines and mills has been greater and prices have been better all round. It is expected that the year will show considerably better earnings. The outlook for 1913-14 is also good. Orders on the books of the company are greatly in excess of last year, and prices are also better.

THE QUEBEC BRIDGE.

THE revised design for the Quebec Bridge is so far advanced that details of the principal members are available. The main span is 1,800 ft. long. The top chord members of the cantilevers will consist of double lines of 16 in. I-bars. The bottom chords will be 7 ft. in height by 10 ft. wide. The length from panel point to panel point will be 86 ft., and each full panel of the bottom chord for one truss will weigh 200 tons. Each cast iron base for the towers will weigh 500 tons. The stringers reaching from panel point to panel point are massive plate girders 10 ft. in depth, each weighing about 60 tons.

INTERNATIONAL ENGINEERING WORKS.

THE following have been elected officers and directors of the International Engineering Works, Ltd., for the ensuing year: Messrs. C. H. Cahan, president; H. A. Lovett, vice-president; R. Garrett, general manager; D. W. Robb, G. F. Gyles, treasurer; G. W. Cole, R. Bruntinel, director. The International Engineering Works is the reorganization of Robb Engineering Co., with works at Amherst, N.S., and South Framingham, Mass.

A good salesman is like a good cook, he can create an appetite when the buyer isn't hungry.

PIPE MOULDING IN FRANCE 145 YEARS AGO.

By Joseph Horner.

PLATES I, II and III show the art of moulding different forms of pipes or tubes for the conveyance of water, as illustrated in the old 18th century French Encyclopaedia of Diderot and d'Alembert.

Plate I—Features.

Fig. 1, plate I, is a section through what is termed an "ancient pipe"—an old design (c) (h) being the box or socket for receiving another pipe, and (d) (e) a circular cushion applied to the socket of a pipe to be jointed to it. Fig. 2 represents the same pipe in perspective, and Fig. 3, two pipes of the preceding type assembled or united. Fig. 4 is the pattern in halves for one of these pipes (A) (B) being its core-prints. The socketed end (B) (B) is to be one or two lines larger than the diameter of the part (a) (a) the spigot—this having been written before the metric system was introduced. The English inch was then in use, and there were twelve "lines" to the inch. Fig. 5 shows the two parts together (f) (d) being the dowels.

The core for all these pipes was made in loam and applied in several layers. It was mixed with horse manure, or with hair to give the necessary consistency. Each bedding was dried before the application of the next. The number of layers ranged from six in large pipes to two in small ones. Faults were made good, and charcoal dust diluted and applied over the finished surface while the core was warm, the core not being put into the mould until perfectly dry.

The mould, of sand, was formed in two box-parts, one of these being taken and laid on a bottom-board with the joint face on the board, over the half-pattern which has the dowel holes. Coal dust was strewn over, and the half-box filled with sand in layers, laid all round and on the pattern. It was rammed and strickled off with a rule. On turning the box over on the board, the joint face came uppermost to receive the other box part, which was rammed similarly. Afterwards, four or five holes were pierced with a knife to serve for runners and risers. Two of these holes were set, one on the spigot, one on the socket end, and the others on the body. The parts having been separated, the core was inserted in its print impressions (A) (B), after which the mould was closed.

Fig. 6 shows other ancient pipes—even at that period, united with a muff or ferrule, which we should term a thimble. We are told that these sorts of pipes were to be abandoned, because

it was so difficult to replace one in the middle of a series, hence the reason of the invention of pipes with "ears" (flanged pipes), with two, three, four, six, or eight ears. Fig. 7 is a pipe with two ears, Fig. 8 one with three ears, and Fig. 9 one with four ears. Each ear had one hole to receive the screw that unites the pipes, as shown in Fig. 10. Leather washers were fitted in the joints. Fig. 11 has hexagonal "brides" or flanges, and Fig. 12 octagonal ones.

Plate II—Features.

Plate II gives examples of pipe moulding. Figs. 13 and 14 is a pump body,

additional. The diameter of the core is twelve inches, and the diameter of the outside, fourteen inches. The models of the half flanges are drawn at the ends.

The core having been prepared by sweeping up, the mould was made in the box shown. This was of wood, one and a half inches thick, dove-tailed at the corners and strengthened with corner angles of iron. Each of its longer sides was pierced with two mortises of three inches in width, Figs. 17, 18, and 20. To receive the tenons of the plates, Fig. 19. These mortises permitted of lateral movement of the plates to suit the

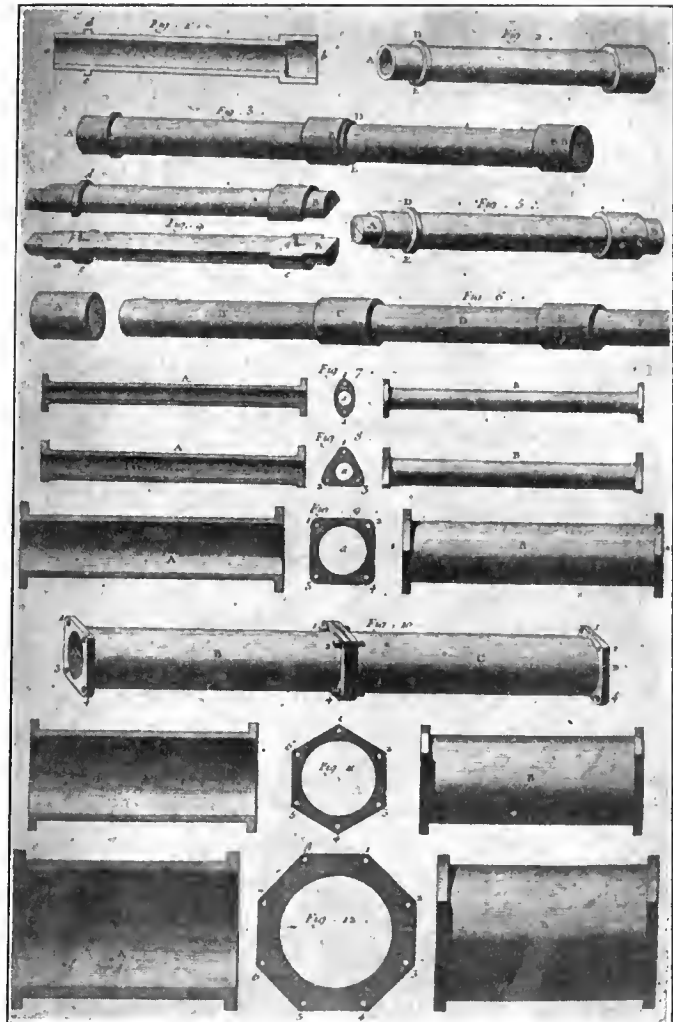

PLATE I. PIPE MOULDING IN FRANCE 145 YEARS AGO.

eight inches in diameter, and four feet long, with a foot (B), a branch (C) and an arm (D) for the lever. Fig. 15 is a section through another pump body, one of suspended type. The parts (B) (C) (D) carry the pump vertically in timber framing. The remaining figures relate to the methods of moulding. Fig. 16 and the following figures relate to the making of the pipe represented in Fig. 11, of the preceding plate I. Fig. 16 was the model or pattern. This was composed of two parts (A) and (B), three feet long, the prints (x) (y) being

lengths of cores. One of these box-parts was placed on the bottom-board over the half-pattern (A) in Fig. 16, the dowel holes being lowermost. The prints (x) (y) passed under the holes in the plates, Fig. 19, being adjusted to the length over the flanges. Next, the patterns of the two half-flanges were taken and set between the shoulders of the model and the plates. Having these parts thus set, charcoal dust or coal dust was strewn all over, and the sand rammed in detail.

This half of the mould was now turned

upside down on the bottom-board, and having fitted the second half of the box, and the second half of the model and its flanges and plates, this was rammed as represented in Fig. 18, but separated from the bottom part. Fig. 17, below. The holes (e) (f) (g) (h) (i) in Fig. 18 were cut with a knife to serve for runners and vent-holes. The two parts of the mould were separated to permit of the withdrawal of the model. Having loosened the plates, the moulder removed by the edges of these models (nothing about rapping or lifting holes), the body (A) and (B) Fig. 16, and after-

Figs. 17, 18 and 19. These little cores traversed all the space or thickness which the half-flanges occupy, and enter slightly into the sand opposite. Each core carried a point of iron to serve as an axis to enter the opposite sand. The end of the core being cut square, its security was well assured. Sand was heaped up lightly with the hands in the space between the plates and the ends of the box, so much so as to secure the pegs or cores of loam in their holes and prevent the metal from running in.

In Fig. 18, which is, as already mentioned, the box-part containing the sec-

actly the main core, and the six holes receive the bolt cores.

Fig. 20 is a plan of the bottom box-part in Fig. 17 resting on its mould board, where (a) (b) is the arbor, and (N) (N) the core; (c) (e) (e) is the space into which the metal runs. The plates (C) (D) (C) (D) carry the bolt cores through the flange thicknesses. Fig. 21 is a transverse section of the mould near the exterior of the plates (A) (B) (C) (D). The core arbor is shown at (e) (d) being its make-up box or "trousseau"; (e) the straw ropes; (f) the loam, and (1) (2) (3),

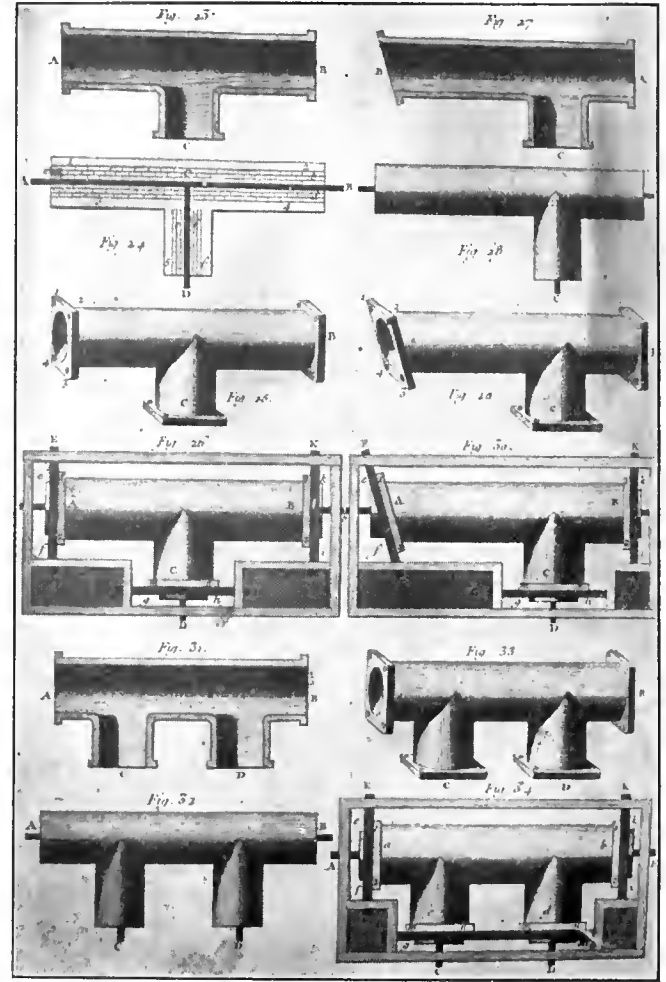
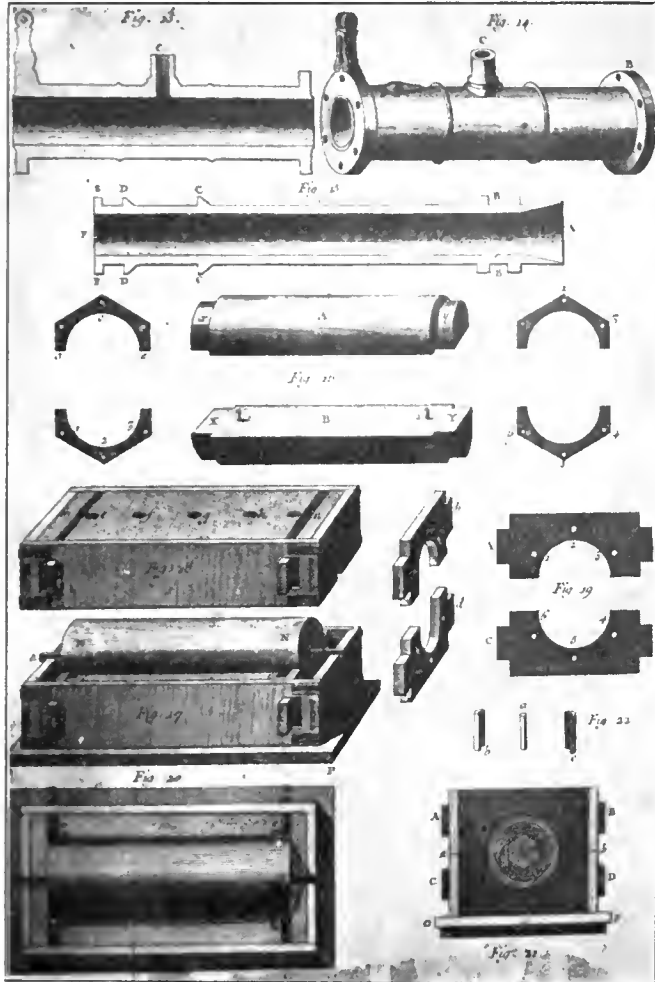

PLATE II. PIPE MOULDING IN FRANCE 145 YEARS AGO. PLATE III. PIPE MOULDING IN FRANCE 145 YEARS AGO.

wards the models of the half-flanges. Then the core (N) (N) Fig. 17 was laid in, that is, placed in the circular notches of the plates. The square ends of the arbor (a) (b) of the core engage into the notches that are cut in the box ends. There remained then in the space between the core (N) (N) the sand, (e) (c) and the plates, a space equal and similar to the thickness of the castings required, made and moulded as has been said. In order to core out the bolt holes in the flanges, six little pegs and plugs (cores) of loam (a) Fig. 22, made in the box (b) (c) were introduced into the three holes of each one of the plates,

and half of the mould in which the runners and risers have been made, the sand is seen filled in at the extremities (n) following the fitting in of the cores for the holes in the flanges just described. In this figure, and in Fig. 17, the wedges (which secure the joints of the plates (1) are omitted to show better the mortises in the sides of the box along which the plates are adjustable. Except for these wedges, Figs. 17 and 18 show the two moieties of the mould in the state in which they are completed ready to receive the iron. Fig. 19 illustrates the plates of iron in plan and in perspective. The semi-circles embrace and

etc., the cores for the bolt holes. Fig. 22 shows a core (a) made in a wooden box, the halves of which are at (b) (c). The halves were channeled in their length and dusted with coal or charcoal powder and closed. The loam was mixed with horse manure or hair, and rammed with a dabaton. The shells were separated, and the core (a) dried. These were made in large numbers and kept in stock.

Plate III—Features. Fig. 23 shows a pipe with a central core and six smaller cores. Plate III represents different kinds of pipes having branches of about eight inches diameter, moulded similarly to the preceding. Fig. 24 is a section of a

branch pipe with four eared flanges, and Fig. 24 is a section of the core for same. The formation of the core commences on the arbor of iron (A) (B), being pierced with a mortise at (C) to receive the arm (C) (D). The straw rope encircling the arbor is shown at (a) (b) (c) (d) and 1, 2, 3, 4, is the loam. After this had been swept up, the branch core similarly swept up was fitted and secured by the mortise. Fig. 25 shows externally the pipe and branch casting finished, and Fig. 26 shows externally the model in the box-part. The model is dowelled along the centre and fitted with half-flanges. The reference letters used need not be detailed, the plates (E) (F) (G) (H) (I) (K) being similar in shape and function to those shown in the previous plate, which carry the bolt cores for the several flanges. The spaces seen behind the plates, (e) (f) (g) (h) (i) (k), were the means by which the cores were introduced to their holes after having removed the models. Afterwards, these spaces were filled with sand. Seven runners and risers were cut, five on the pipe, two over the flanges, and two others on the branch. The chambers (F) (G) and (H) (I) in Figs. 26 and 30 were made to reduce the sand space, because their filling up with sand would be useless.

Fig. 27 is a section through a pipe with one flange set obliquely, and Fig. 28 is the core for the same. Fig. 29 is the same pipe in perspective, and Fig. 30 its model, which, excepting for the oblique setting of one flange, resembles Fig. 26. Fig. 31 is a section of a pipe with square flanges, and two branches, Fig. 32 being its core, Fig. 33 the casting in perspective, and Fig. 34 the model in its box.



MODERN SHOP GRINDING.

By J. D. Smith.

SINCE the introduction of grinding machines a far greater degree of accuracy has been obtained than under the old conditions and with the old method of using the file to smooth a job up in the lathe after it had been turned. In some cases the spring finishing tool was and is used. This was of necessity a slow method, as finishing could only be done at slow speeds. Then, again, there was always the chance of a "waster," due to the tool drawing in, it being necessary to present such a wide cutting tool nose to obtain the desired finish. Supposing we eliminated the question of greater accuracy from grinding, we should still have a factor of much importance to consider—time saved.

There is no hard and fast rule laid down as to the amount of material to be

left on by the turner for grinding—some shops making a practice of allowing one-hundredth part of an inch, while others leave one sixty-fourth; but from my own experience I think that the length of the job ought always to be taken into consideration when fixing the amount to be left on, as a long job will always be found to be oval in the centre on account of its only being rough turned, even although a steady rest has been used while turning.

What Can We Rough Turn?

When installing a grinding machine, the first thought is always: "What can we rough turn?" Now, when a man is given instructions by his foreman to rough turn an article he naturally does not take as much pains with it as when he had to finish it smooth, therefore the need of a set or sets of rough-turning standards. These are plug standards, turned to whatever limit is decided upon, say, one-sixty-fourth large, but not case-hardened, as they are only intended for the men to set their calipers to, and can be kept in a central position on a stand in the shop, instead of in the tool stores. The use of these standards will be found to repay their cost over and over again, especially if the men are working piece work, for in the case of the grinder reporting too much metal being left on, which he certainly will do if working on this plan, the question can always be settled by referring to the standards. This practice is also more conducive to regularity of sizes, it being far better to provide a standard for the men to work to than to allow them to take their own sizes by means of calipers from steel rules. Should a better method be desired a set of horseshoe standards can be made. As these are more liable to get knocked about than the short plugs, they should be kept in the tool stores and checked periodically, as they will wear more quickly owing to being used continually for rough work.

Case-Hardened Work.

A very great benefit has been derived from grinding machines in shops which have a quantity of case-hardened work to contend with, such as machine tool and locomotive works. It is the usual practice under the old methods to turn the articles as near to size as possible, with a high finish before case-hardening, then, providing there was no distortion after hardening, to polish them up with emery sticks in a polishing lathe. This was at best a poor way, but it had to serve, as there was no other, and many a poor case-hardener has had to listen to lengthy sermons from the foreman when articles have had to be replaced owing to distortion on account of their being machined to size before hardening. These

cases occurred as usual with articles which were most urgently needed.

Again, there was the question of handling, for the articles having been machined so near to size, had to be carefully dealt with so as to avoid marking, and it is no easy job lifting a white hot article out of a case-hardening box with a pair of tongs without marking it. Under the new conditions, articles can be left rough where they have to be ground, providing they are left in the hardening box sufficiently long to allow the hardening to penetrate the extra depth left on for grinding; also there is not so much time wasted in trying to straighten a distorted article; in fact, no time need be taken at all if the article is only distorted within the limits of the extra amount which has been left on.

Internal Grinding.

Up to this point the question of plain grinding has only been considered, but there are makers such as Landis and Browne & Sharpe, who make machines which can be used either for plain or for internal grinding. These machines are more adaptable for the small sized shops, which cannot afford to go to the expense of both a plain and an internal machine, or for a tool room where the work is of a more varied character, but the capacity of the machine must always be borne in mind, as it is not usual for these machines to have a gap; therefore, the capacity of the chuck is restricted to the diameter of the largest straight piece which can be ground internally.

The introduction of internal grinding has been most beneficial, especially in connection with case-hardened articles. It has been so far practically impossible to get a round straight hole after hardening, the only means which could be used being lead lapps. When a taper hole was wanted, such as a twist drill shank standard, it was a work of art to get anything approaching the sizes required, but with the advent of internal grinding all these troubles have vanished.

Grinding Wheels.

Naturally a great deal of intelligence must be brought to bear to get the best results; it would not do to install a machine and relying on the one or at the most two emery wheels supplied with it, expect to be able to put anything in the machine within its limits and get a first-class job, irrespective of the material of which the job is composed. Machine makers usually supply grinding wheels which are most suitable for ordinary mild steel, unless specially requested to the contrary. All makers of emery wheels not only supply various shapes to suit various jobs, but what is of more importance, various grades of hardness, signified by a letter; M being usually

used for medium, and all letters preceding, such as L, K, J, I, being softer in the order given, and all letters after, such as N, O, P, Q being harder.

The grade ordered depends entirely on the material to be ground the rule being the harder the material the softer the wheel; the general rule being F to K for brass or brouze, K to M for cast iron, L or M for soft steel, I to M for hardened steel, according to finish required, emery 40 to 100, according to amount of material to be removed and finish required, 60 being a good average for external grinding, and 50 for internal. This can only be found by experience, according to the character of the work being dealt with, notes being taken on the results of every grade used.

Grinding Machines Indispensable.

The grinding machine is indispensable in an up-to-date shop, articles being made commercially possible by its use which were previously out of the question, such as hardened spindles in lathes, milling and drilling machines, planing machine worm drives, crank pins, cross-head gudgeon pins, piston rods, etc. Such metals as nickel steel, tool steel, etc., can be ground from the bar without being turned in the lathe at all, thereby decreasing the cost considerably; in fact, many firms have adopted the practice of ordering their black mild steel bars to bare one-eighth limit and grinding from the rough, as the later and more up-to-date machines are capable of removing the metal far quicker than the lathe.

Another point worthy of consideration is that far simpler lathes can be used for the roughing process, which means less capital invested in machinery, or the same capital which would be required for one up-to-date gap, chucking, surfacing and screw-cutting lathe can be spread over two or three lathes of simpler form, thereby having a better feed for the grinding machines and less chance of them standing idle.—Machine Tool Engineer.

DESIGN AND ECONOMY OF DIESEL ENGINES.

A PAPER entitled "Some Notes on the Design and Economy of Diesel Oil Engines" was read by Captain H. Riall Sankey before the Association of Engineers-in-Charge, recently. Comparing the cost of running Diesel engines with other prime movers, the author pointed out that the condensing steam engine can for short periods give as much as 50 per cent. above the rated power, while non-condensing steam engines and the Diesel engine can give 10 per cent., but the gas engine can usually

only do its rated power for short periods, and about 85 per cent. continuously. Taking the case where an average load of 200 horse-power and a maximum of 300 horse-power for short periods is required, and the total running hours 3,000 per year, the following total annual costs were given:

Non-condensing steam plant, \$7,225; condensing steam plant, \$5,280; oil engine, \$5,275; gas engine suction producer, \$5,030; gas engine pressure producer, \$4,980; Diesel engine, \$4,660; overtype superheated condensing plant, \$4,395. In this connection, interest on capital was taken at 5 per cent., and stores, labor, maintenance, repairs, and depreciation and fuel cost were taken into account. The latter cost per ton were taken as: Oil, \$10; coal for pressure producers, \$4.50; coal for suction

ers and switch gear. Moisture is perhaps the most serious enemy. The author of the paper argues that, except during rain, the air is usually drier outdoors than in, because in the latter case, the air is warmer and fed with moisture from the respiration of people.

BUYS CANADIAN ORE.

THE Nova Scotia Steel & Coal Co., New Glasgow, N.S., has secured a contract to deliver a large quantity of high grade iron ore to the Krupp firm at Essen, Germany, for use in the armament works. The European as well as the American demand for this ore has been steadily increasing, the figures showing that, during the last 10 years, over 3,000,000 tons have been shipped to these markets. This year's shipments abroad are expected to amount to 500,000 tons.

Miscellaneous Data

Aluminium Shot.—Aluminium shot, so called, is simply irregular and rounded pieces of aluminium, some of the smaller of which resemble shot. The material is made by pouring melted aluminium into cold water. The best method is to make a flat-bottomed iron ladle and bore a number of small holes in the bottom. The aluminium is poured through this and the drops issuing from the holes form shot-like pieces when they strike the water. The higher the metal is poured from the water the more irregular the shot, as it flattens when striking the water under this condition.

Aluminium Solders.—Aluminium solders, states the Ironmonger, continue to engage the attention of inventors. A recent solder patented by an American is composed of the following:—Tin, 60 lb.; zinc, 15 lb.; lead, 10 lb.; antimony, 5 lb.; bismuth, 5 lb.; chromium, 5 lb. The metals are melted, and then treated with "35 grammes of salicylic acid and 10 grammes of calcium to each 5 lb. of the alloy, and for a like amount of material 2 grammes of sulphur." The inventor states that the sulphur acts as a "binding agent." The solder is used with the ordinary solder fluxes for soft solder and in the same manner. Another solder known in America as "Richards" aluminium solder, and said to have stood the test of time, is composed of the following:—Tin, 29 oz.; zinc, 11 oz.; aluminum, 1 oz.; 5 per cent. phosphor-tin, 1 oz. The first three ingredients may be melted together, after which the phosphor-tin is added.

DON'T ANTICIPATE FAILURE

Don't "try" advertising, expecting that you will only waste your money. Success is not won in that way. Buy advertising — choosing it carefully—just as you would buy any other staple product needed in the growth and management of your business. Use it as a tool which, rightly handled, cannot fail to produce the desired result. The attitude of some men towards advertising reminds one of the editor who wrote this item for his paper:—"Our esteemed fellow-citizen, William H. Jones, will be operated on to-morrow by Dr. Perkins. He will leave a wife and three children."

producers, \$7.00; coal for steam boilers, \$4.50. Only 120 tons of fuel are required for the Diesel engine, while 1,022 tons are required for the non-condensing steam plant.

ELECTRICAL APPARATUS OUT-OF-DOORS.

IN a paper read before the American Institute of Electrical Engineers, the question of using electrical apparatus out of doors is discussed. The advantage of such installations is mainly a reduction in first cost, but in a few cases, as where very high voltages are handled, fire and even personal risks are probably reduced. A large number of these out-door installations are in use in the States, but it is to be noted that, so far, most of them are in the more southerly States. Snow, it seems, would be more objectionable than rain for switchgear and moving appliances. Most of the out-door installations consist of transform-

MACHINE SHOP METHODS ^A_N^D DEVICES

Unique Ways of Doing Things in the Machine Shop. Readers' Opinions Concerning Shop Practice. Data for Machinists. Contributions paid for.

PISTON RING GRINDING MANDREL

By H. R.

THIS is a very accurate method of grinding up piston rings before being split. It comprises a steel body piece

to give strength. Mounted on this base are two steel pillars (B)-(B1) which are held in position by the nuts (C)-(C1). They are screwed at the opposite ends into the steel cross member (D), which is a solid steel casting forming the bear-

(F) on to the cast iron pressure plate (E), the latter being prevented from revolving by being guided by the steel pillars (B)-(B1). The screw is operated by the bevel wheel (G), which is keyed to the steel screwed bush (H) and runs in a phosphor bronze bush (I).

Power is transmitted from the line shaft to a countershaft, and from there to the flanged pulley (J) which is keyed on to the shaft (K). The gears (L)-(L1) are also keyed to this shaft (K). These gears operate the pinions (M)-(M1), keyed to the shafts (N)-(N1) and form the drive of the bevel pinions (O)-(O1). These pinions slide on the castelated ends of the shafts (N)-(N1). To operate the press, the pulley (J) is set in motion, and one bevel gear is engaged with the bevel wheel (G). This revolves the screw (F) in one direction and by the stops (P)-(P1) engaging with the levers (Q)-(Q1), one bevel pinion is forced out of action and one forced into action. This method makes its motion absolutely automatic and reverses the action of the screw (F). The springs (R)-(R1) give an instantaneous action to the levers (Q)-(Q1), and the bevel pinions (O)-(O1). With the plate on its upward or downward travel, as the case

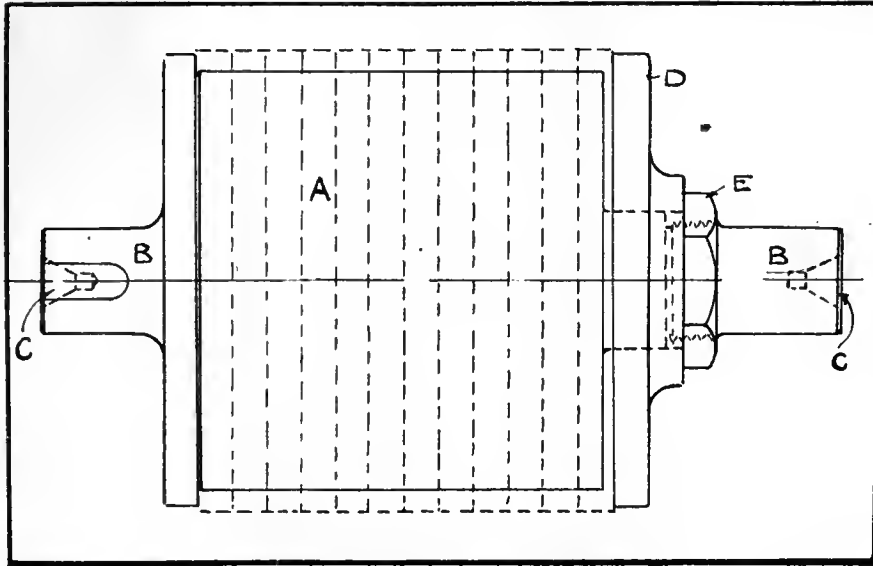

PISTON RING GRINDING MANDREL.

(A), out of which are turned the ends (B) and into which are drilled the centres (C). A flat milled upon it forms a driving end and out of the other end are formed a spigot and a screwed portion for the flange (D) and the nut (E). This is afterwards hardened and ground true in the centres (C). To operate, the piston rings are slipped on to the barrel portion of (A) then the flange plate (D) is located on the spigot, the whole being held securely by the nut (E). The barrel is ground true to the bore of the piston rings—0.01 in., and the outside flanges are the finished diameter of the outside of the rings. This eliminates the necessity of a grinding gauge.

ings for the necessary gearing. The pressure is applied through the screw



AN AUTOMATIC SCREW PRESS.

By H. R.

THIS machine was designed for the rapid production of pressed work where it had to be pressed to certain depths for baling purposes. It was essential that the work should be done at little cost, and in quick time. This has all been accomplished, and there are now several machines at work doing good service.

The construction consists of a cast iron base (A) of suitable section so as

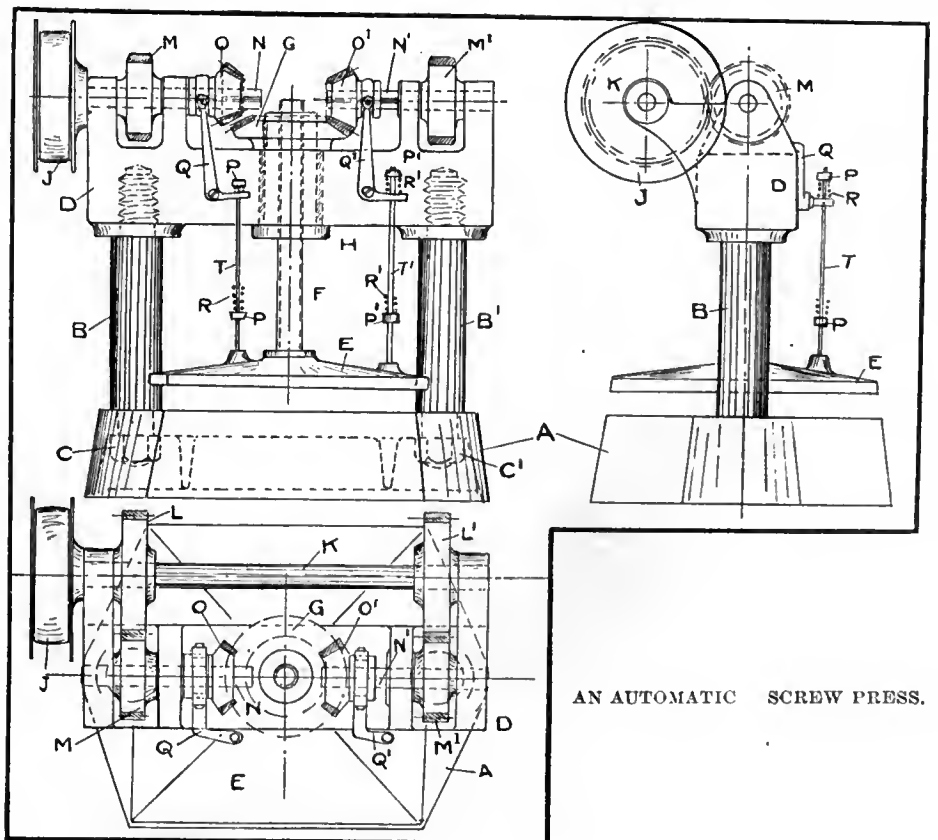

AN AUTOMATIC SCREW PRESS.

may be, before the stops take action the springs are in contact with the levers (Q)-(Q1). As soon as they become a solid mass the action of the springs free the bevel pinions instantaneously. The stops can be adjusted on the rods (T)-(T1) so that any distance of travel can be obtained. It is necessary to adjust the stops so that the one bevel pinion is clear of the bevel wheel (G) before the other one starts to slide.

LATHE ATTACHMENT.

By J. H. R.

THE accompanying sketch shows an attachment placed on a small lathe to increase the range whereby work of larger diameter can be accomplished. The head (A) is secured to the bed of the lathe as shown, so that the shaft (B) is in a parallel position to the lathe spindle, but somewhat above it. This shaft or auxiliary spindle is threaded on the end to take the ordinary face plates or chuck that goes with the lathe. Back of the bearing (E) and keyed to the spindle (B) is the large gear (C), which meshes with the small gear (F) keyed to the shaft (G). At the other end of the shaft (G) and keyed to it is the gear (H), which meshes with the gear (J). This gear (J) has a hexagon on the back, and is threaded to fit the lathe spindle. The end play of the auxiliary spindle (B) is adjusted by the lock nuts (D).

By this arrangement the feed gears on the lathe are not interfered with, which sometimes proves a difficulty when the head of the lathe is raised on parallels, as is necessary at times in the ordinary jobbing shop. The lathe is run in the usual way, the arrangement of the gears (J), (H), (F), (C) being such that a slower speed is given to the increased diameter.

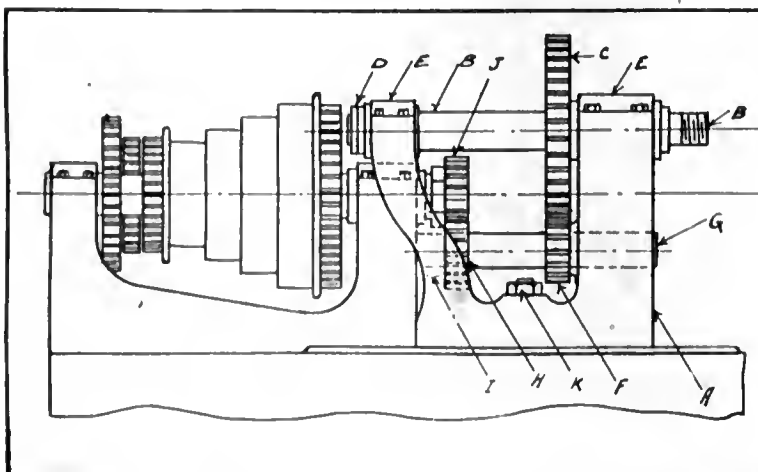

LATHE ATTACHMENT.

MILLING MACHINE TURRET.

By H. R.

THE illustration shows an indispensable milling machine attachment on which many jobs can be performed. It is especially adapted for repetition work. Jigs can be made up and bolted to the face at the various slots, and while the machine is engaged on one set of work, the operator can lead up another set and index it round to its proper position.

The construction consists of a cast iron base plate (A) which has provision

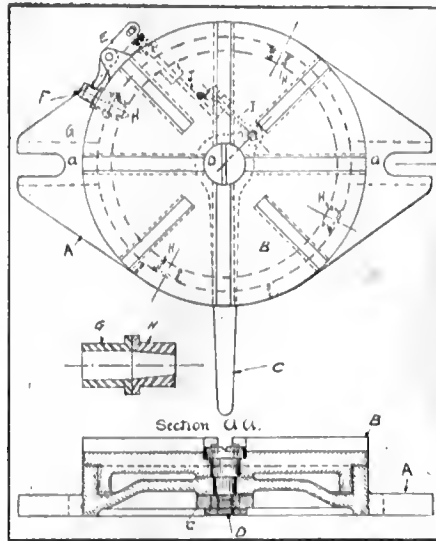

MILLING MACHINE TURRET.

made for bolting to the milling machine table, and out of the base (A) is formed the locating spigot on which revolves the top plate (B). The hand indexing lever (C) is held securely to the base-plate and top-plate by the centre pivot (D), and two lugs are cast on to the base, between which is pivoted the indexing lever (E), for operating the

plug (F). This plug is made on a slight taper and has a tendency to wedge itself into the steel bushing (G) (G). The bushing (H) is fixed into the base-plate (A) and there are four or more bushings as may be desired fixed into the top plate (B).

The whole machine or structure is easily and conveniently operated. By pushing the hand lever (C) to the left. The rods (I)-(J) are operated through to the index lever (E), which pulls out the plug (F) from the index bush (H). The table is then revolved to its next position when the plug (F) springs in place.

Storage of Chemicals. — In a paper read before the recent eighth International Congress of Applied Chemistry, attention was drawn by Dr. Julius Aeby to the numerous dangers which are likely to arise during the storage of various heavy chemicals owing to reasonable precautions not being taken to guard against their occurrence. Bleaching powder will occasionally decompose under elevation of temperature, though it is claimed by the manufacturers that this only occurs when the material is new; potassium permanganate if accidentally mixed with sawdust or fine sweepings will ignite by friction; arsenic acid may retain enough nitric acid to burst its drums during excessive heat, say, in the summer time; metallic sodium must be kept away from air and water; and cyanamide should be kept from water and naked lights, on account of the occasional presence of calcium carbide in it. An ample instance of the latter danger was furnished recently by the loss of a Norwegian vessel which was carrying a cargo of cyanamide.

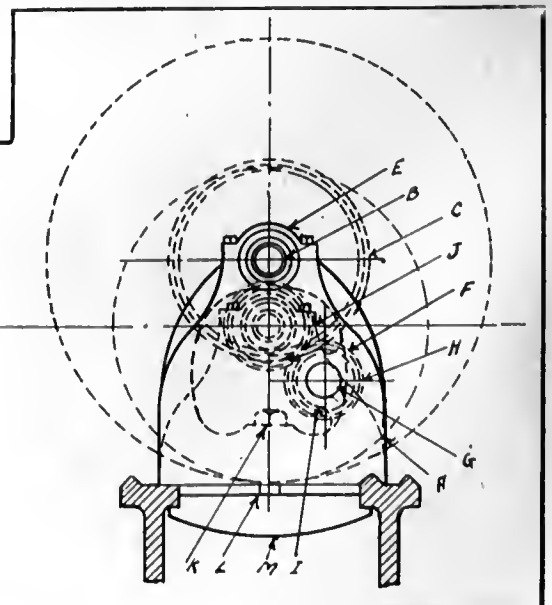

DEVELOPMENTS IN MACHINERY

A Record of New and Improved Machinery Tending Towards Higher Quality and Economical Production in the Machine Shop, Blacksmith Shop or Planing Mill.

A NEW PAPER MILL ENGINE.

THE fundamental requirements of a variable speed paper mill engine are a speed range equivalent to the desired speed range of the rolls, and, as nearly as possible, perfect regulation at all speeds. The usual type of paper mill engine has two horizontal cylinders with cranks at an angle of 90 deg. The range of speeds obtainable is, however, limited, because the unbalanced reciprocating forces prohibit operation at high speeds, and because, below a certain speed, the turning effort becomes uneven and the fly-wheel less effective in evening out the speed, thus setting a low limit below which regulation is seriously impaired. An engine of this type would have speeds from, say, 75 to 300 r.p.m., depending on the size and giving a range of 4 to 1.

Where a wider speed range is wanted, some form of speed change gear must be placed between engine and shafting. The simplest gear is a belt and pulley arrangement, and this in connection with two cylinder engines has proved a re-

liable paper mill drive. The drawbacks, however, are that the arrangement of pulleys and belts complicates the plant, consumes power, increases attendance and maintenance, and involves loss of time in changing speeds. Ordinarily, it requires from one to two hours to change over from one pulley to another, and, since it is necessary to shut down the plant while doing this, there is a loss of output amounting to one or two per cent., if the speed has to be changed, say, once a week.

Influence of Reciprocating Forces.

The secret of engine design for wide speed range on paper mill drives is to arrange the cylinders and design the reciprocating parts and counter-weights so that the reciprocating forces are neutralized. It is an erroneous impression that counter-weights attached to the heel of a crank will neutralize reciprocating forces. As a matter of fact, a counter-weight on a horizontal engine merely transfers the thrust from a horizontal to a vertical plane, thus causing a direct impact on the engine frame

and on the foundations, instead of a sideways or lateral push. In slow speed engines these unbalanced forces can be taken care of by heavy foundations and foundation bolts, and no serious trouble may occur; but since these forces increase as the square of the velocity of the reciprocating parts, a definite limit is soon reached, beyond which the speed of an improperly balanced engine cannot be increased.

Four-Cylinder Paper Mill Engine.

The American-ball four-cylinder paper mill engine, shown in Figs. 1, 2 and 3, is designed with four cylinders, arranged in pairs at right angles. The engine is thus built of two units, each of which has a vertical and horizontal cylinder. Each pair of vertical and horizontal pistons drives a common crank pin, and there are eight power strokes per revolution, evenly distributed 45 deg. apart. A counter-weight on each crank transfers the horizontal reciprocating forces from a horizontal to a vertical plane, in which they meet equal and opposite reciprocating forces from the vertical

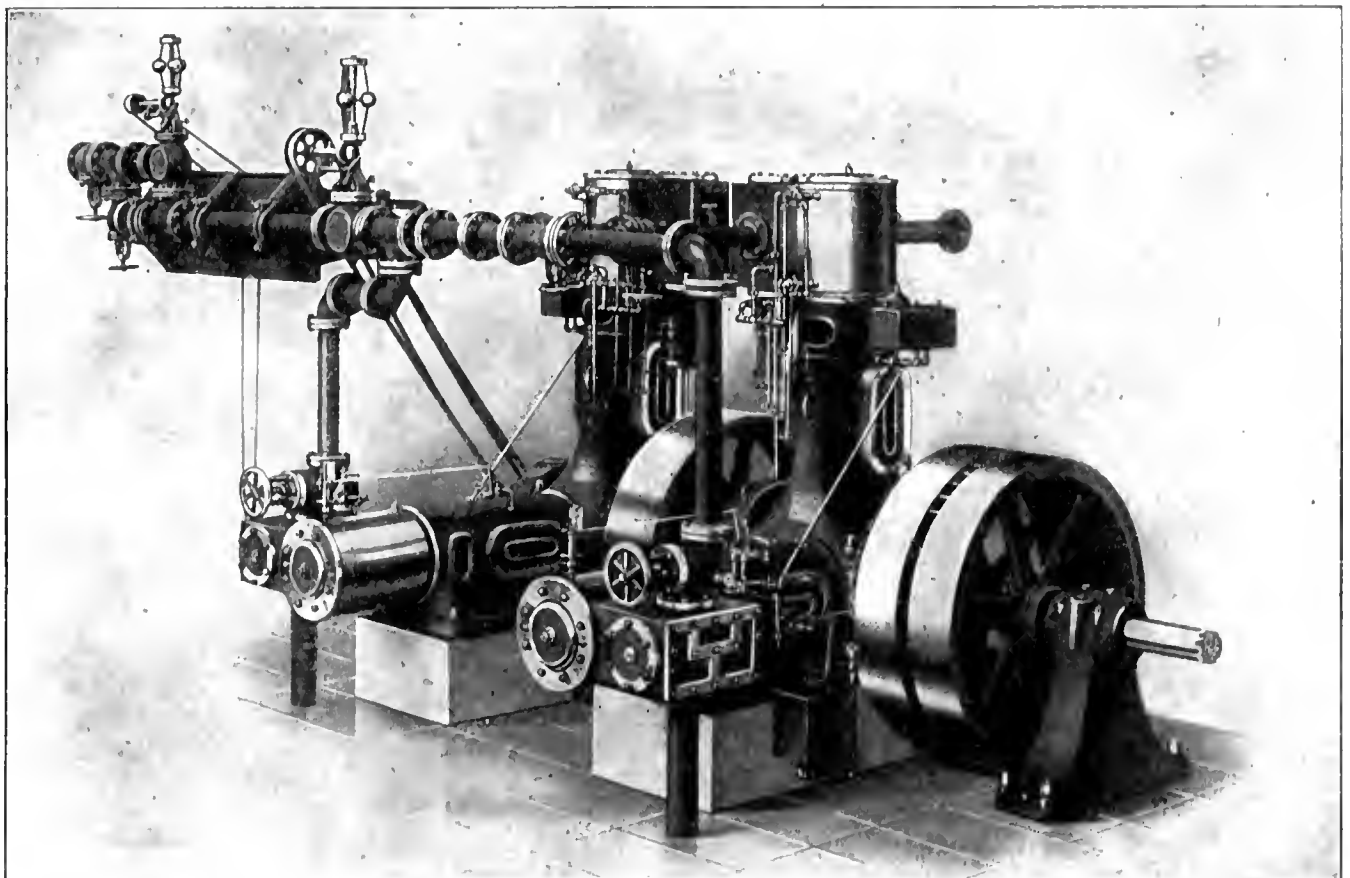

FIG. 1. AMERICAN-BALL FOUR CYLINDER VARIABLE SPEED PAPER MILL ENGINE.

reciprocating masses, which, therefore, neutralize unbalancing.

The balancing of this engine is claimed to be so perfect that it may be operated at speeds of 400 to 500 r.p.m. Furthermore, the engine may be operated at the low speed of 50 r.p.m. with

American-ball paper mill engines. The devices illustrated perform a number of important functions, and, in fact, are a most important part of the whole engine equipment. Two governors are used, each being of a standard type, specially improved and adapted to the particular

exceeds the predetermined limit, the mechanism is tripped and the weighted lever closes the valve. At all normal speeds this governor valve has no throttling effect, hence it cannot affect the engine speed. The second governor, which may be seen to the left in Fig. 3

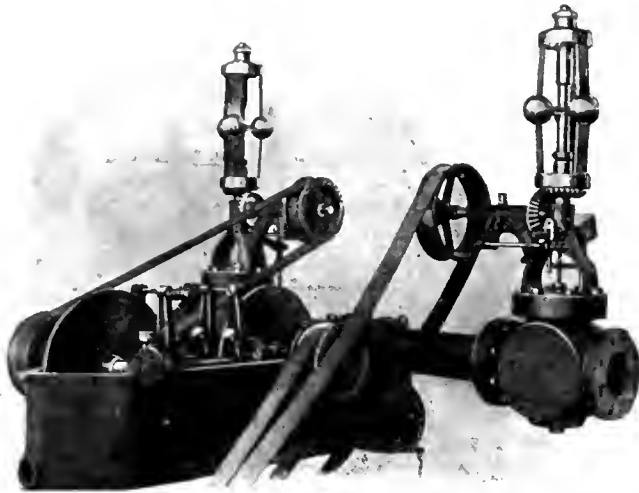

FIG. 7. BALL BEARING AND SPEED CHANGING MECHANISM.

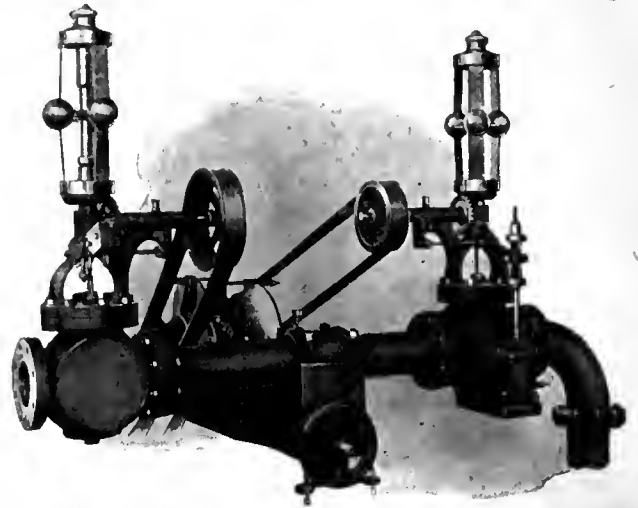

FIG. 8. BALL GOVERNING AND VARIABLE SPEED MECHANISM.

good regulation, so that a total speed range of 8 to 1 and even 10 to 1 may be obtained. The engine may be coupled directly to the line shafting, and delays, complications, space requirements, loss of power and other drawbacks of belt gearing between engine and shaft eliminated.

Speed Change Mechanism and Governors.

Figs. 3 and 4 show the speed changing and governing mechanism as used with

service. The first governor is the automatic engine safety stop, and is placed nearest the steam supply pipe, being shown at the right in Fig. 3.

As may be seen, this governor is driven by belt direct from the engine shaft and is fitted with an automatic tripping mechanism. The steam valve remains wide open throughout the whole normal range of speeds for which the engine is designed, but in case the speed

and to the right in Fig. 4, controls the engine speed, and is driven through the variable speed friction device, also shown.

Stabilizing Device.

The requirement of constant speed is a most difficult one to meet. When once the speed of the engine has been adjusted to give a certain grade of paper, the speed must stay constant, and must not be affected by variations in steam pres-

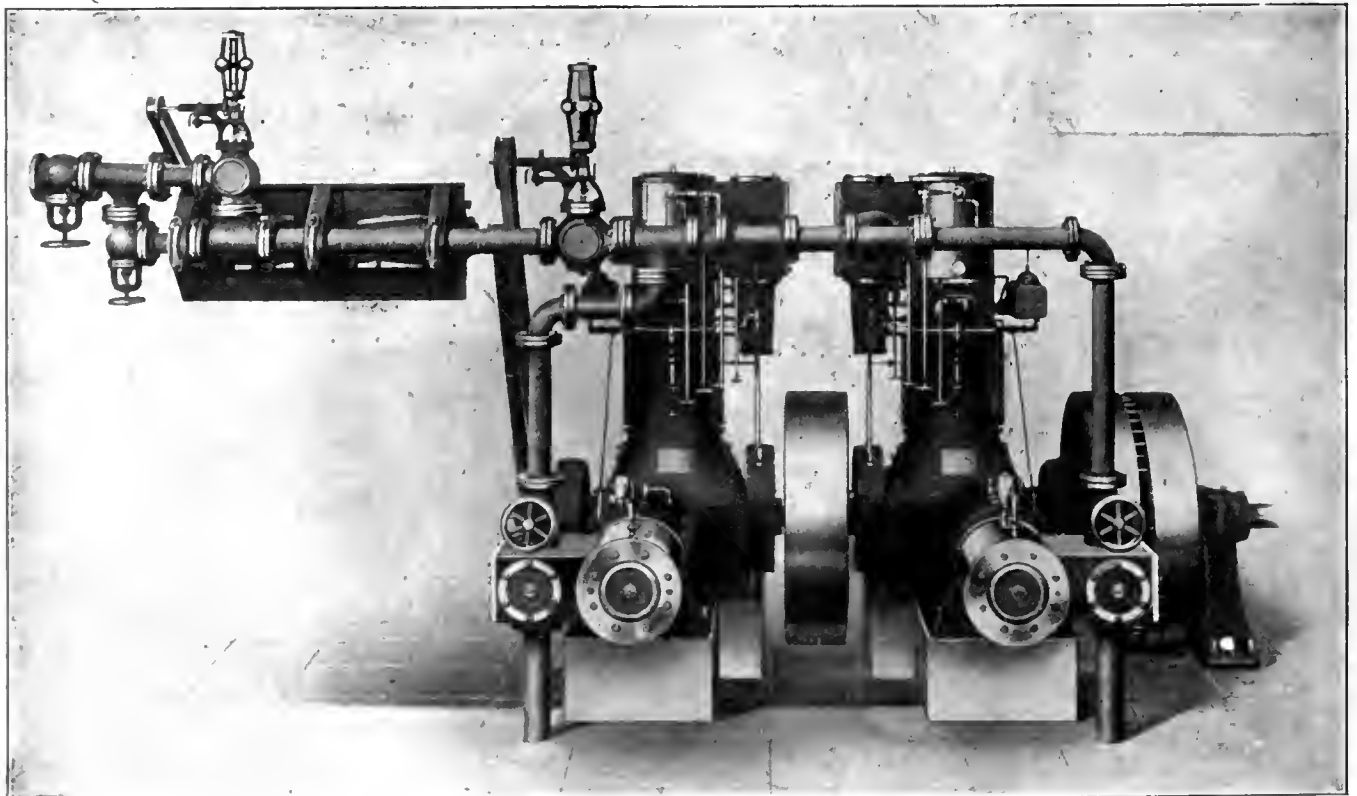

FIG. 2. ANOTHER VIEW OF THE AMERICAN-BALL FOUR CYLINDER PAPER MILL ENGINE.

sure or back-pressure, either of which, with an ordinary governor, will cause surges in speed or hunting and breaking of the paper. To prevent such speed surges a standard governor has been equipped with a mechanism comprising stabilizing springs and an oil pot, which may be seen in the photographs. The piston of the oil pot receives motion from the governor stem through the spring stabilizing device, which absorbs shocks induced by sudden changes in speed of the governor balls.

This stabilized governor is driven from the engine through a variable speed friction device, specially designed, and which may be seen in Figs. 3 and 4. A belt from a pulley on the engine shaft drives a pulley on the friction device, which drives a second pulley through two discs and two pairs of friction wheels. Any speed from minimum to maximum may be imparted to the second pulley, which in turn drives the governor. The two large iron wheels or discs are each keyed to a pulley shaft. Bearing on the surface of these discs are four small friction wheels, one on each side of each disc. The driving disc keyed to the shaft of the driving pulley rotates the two friction wheels held against it by springs, and the second pair of friction wheels drives the second disc and the pulley keyed to its shaft. The speed is changed by simply shifting the position of the friction wheels, which are carried by four rockers located in pairs, each pair being held to a shaft which passes through guides, and may be shifted as desired by a chain wheel and lead screw cut at one end. Each pair of rockers is held together by springs, thus keeping the friction wheels firmly against the discs. All bearings are of the ball bearing type. A patent flexible coupling is fitted to each engine.

The American-Ball Engine Co. are the manufacturers of the foregoing equipment.

CANADA NINTH IN WORLD SHIPPING.

IN the number of vessels and volume of tonnage, Canada's shipping last year showed a substantial increase. The total number on the register books was 8,380, measuring 836,278 tons; an increase of 292 vessels and 65,832 tons, compared with 1911. The number of steamers was 3,667, with a gross tonnage of 641,225. Assuming the average to be \$30 per ton, the value of the net registered tonnage of Canada at the end of 1912 was \$25,088,340. The number of new vessels built and registered during the year was 420, the tonnage 34,886, and the value \$1,569,870. During the year 241 vessels were removed from the register books. It is estimated that

42,490 men and boys were employed on ships registered in Canada during 1912.

Canada occupies now the ninth position in the shipping of all countries, Great Britain and her colonies being first with 12,580,488 tons, Germany second with 3,034,144, and the United States third with 2,617,791. In new shipping last year, Ontario led with 11,170 tons, British Columbia being second with 10,647, Nova Scotia third with 5,853, and Quebec fourth with 5,744. Wrecks numbered 19, strandings 10, and total losses 19.

U.S. EXPORTS CEMENT TO CANADA

AS a result of the temporary reduction of the Canadian duty on American cement, imports of that material into Canada have greatly increased. It is also interesting to note that a Quebec firm is reported to have stated that its American cement, coming in under the reduced tariff, costs 3 cents less per barrel than that furnished by the Canadian merger, and is also of greater strength. In view of this, it is considered not unlikely in some quarters, that when this matter of greater strength is more generally recognized, specifications for future buildings and works will require cement of a strength that will give the American manufacturer of the higher grades of cement a chance in competition with the Canadian product. It is said that the latter, because of the quality of stone available in Canada, cannot equal the quality of the American product.

ESTABLISHMENT OF DRYDOCKS.

THE Government has under consideration the establishment of drydocks at Esquimalt, Halifax and Levis. These drydocks will be primarily used for commercial purposes, but will ultimately, it is contemplated, be employed as naval bases when the Borden permanent naval policy has been worked out.

In answer to a Vancouver deputation which has been at the Capital asking that a drydock be established at Vancouver, the Prime Minister declined to make any promise. He pointed out that a drydock will be established at Esquimalt in view of the fact that it is considered to be the best site for a naval base on the Pacific, should this be determined upon. The Government, however, is willing to assist in the building of a commercial drydock at Vancouver.

Halifax and Levis, it is expected, will form the Atlantic bases.

F. J. Anderson, B.A.Sc., has been appointed city engineer of Niagara Falls.

WATER CONSERVATION IN QUEBEC.

By L. G. D.

GREAT credit should be given the Province of Quebec for the steps being taken for better conserving its waters. This policy was initiated about a year ago by the creation of the Running Waters Commission. This consists of three members, and its purpose is the making of regulations on the disposal, flow, storage and conservation of the running waters, and also to encourage and facilitate the utilization of water-powers in the Province. The Commission's first report which has lately been published, gives a summary of its studies and recommendations, and sets forth its views with regard to the necessity of controlling stream flow, the harmful effects of deforestation, and the possibilities of water storage.

Several hearings were held by the Commission in connection with its work, one regarding the L'Assomption river with a view to interesting the power owners in a water-storage project; and another regarding spring floods of the Chaudiere river. A delegation from the municipalities near Maddington fall was also heard regarding difficulties in connection with the prompt development of this water-power.

A very thorough study was made of a storage system for the St. Maurice river. Engineers were sent out to make the necessary surveys and the result of their investigations is of great interest. The present minimum flow of 0.38 second-feet per square mile could be raised to 1.11 second-feet by adopting the proposed regulation system; and, by the regulated flow and storage dams, the water-power available on the St. Maurice would be increased from 361,320 h.p. as it is at present, to 1,055,652 H.P., an increase of 694,332 H.P.

Under recommendations on the need of accurate data, the report deplores the lack of information available on steam flow, as, at present, such data exist only in a few instances. It urges the importance of establishing gauging stations at once on all the principal rivers. The Commission also recommends a complete inventory of all utilized water-powers, this to be supplemented by an accurate inventory of the water-powers not yet utilized.

The Department of Lands and Forests is also pursuing the investigation of the water-powers of the Province, and the recent issue of the annual report of this Department includes the results of surveys of the Mistassini and Muskosibi (Mistassibi) rivers, where discharges have been taken and heights of the different falls measured.

The MacLean Pub. Co., Ltd.

(ESTABLISHED 1888.)
JOHN BAYNE MACLEAN - - - - - President
H. T. HUNTER - - - - - General Manager
 PUBLISHERS OF

CANADIAN MACHINERY AND MANUFACTURING NEWS

A weekly newspaper devoted to machinery and manufacturing interests, mechanical and electrical trades, the foundry, technical progress, construction and improvement.

H. V. TYRELL - - - - - Business Manager

OFFICES:

CANADA

Montreal, Rooms 701-702 Eastern Townships Bank Bldg.

Toronto, 143-149 University Ave., Phone Main 7324

Winnipeg, 34 Royal Bank Bldg., Phone Garry 2313

Vancouver, H. Hodgson, 2640 Third Ave. West.

GREAT BRITAIN

London, 88 Fleet Street. E.C. Phone Central 12960
 E. J. Dodd

UNITED STATES

New York, R. B. Huestis, 115 Broadway, New York, N. Y., Phone 2209 Rector

Chicago, A. H. Byrne Room 607, Marquette Bldg. 140 S. Dearborn St., Chicago

CABLE ADDRESS:

Macpubco, Toronto. Atabek, London, Eng.

SUBSCRIPTION RATE:

Canada, \$2.00; United States, \$2.50; Great Britain, Australia and other colonies, 8s. 6d. per year; other countries, \$3.00. Advertising rates on request.

Subscribers who are not receiving their paper regularly will confer a favor on us by letting us know. We should be notified at once of any change in address, giving both old and new.

Vol. IX.

MAY 8, 1913

No. 16

PRINCIPAL CONTENTS.

Description of Core Oven Equipment for a Large Foundry	481-482
The Production of Sound Steel Ingots by Compression	483-485
General	488
Creosote and Cross Ties	Nova Scotia Steel and Coal Co.
Sawmill Wrecked	Union of German Machine Tool Manufacturers
Canada Iron Corporation	The Quebec Bridge
International Engineering Works	
Pipe Moulding in France 145 Years Ago	489-491
Modern Shop Grinding	491-492
General	492
Design and Economy of Diesel Engines—Electrical Apparatus Out-of-doors	Buyers Canadian Ore.
Miscellaneous Data	492
Aluminium Shot	Aluminium Solders.
Machine Shop Methods and Devices	493-494
Piston Ring Grinding Mandrel	An Automatic Screw Press
Lathe Attachment	Milling Machine Turret
Storage of Chemicals	
Developments in Machinery	495-497
A New Paper Mill Engine	
General	497
Canada Ninth in World Shipping	U.S. Exports Cement to Canada
Establishment of Drydocks	Water Conservation in Quebec.
Editorial	498
Industrial and Construction News	499-503
Engineering	Electrical
Water Works	Municipal
Wood Working	Building Notes
General Industrial	Railways
Bridges	Marine
Contracts Awarded	Trade Gossip
Personal	Obituary
New Incorporations	
Selected Market Quotations	504-505
The General Market Conditions and Tendencies	505

MAY DAY.

MAY DAY has passed, and the usual happened in that parades of socialists were quiet and uninteresting except for their orderliness. The day will, however, be remembered as forecasting satisfactory labor conditions, and this was verified by an interview with John Foster, president of the Montreal Trades & Labor Council.

"Contrasting the present time with the corresponding period of last year," Mr. Foster said, "a great difference is noticeable. There are at present no serious labor troubles, work is plentiful, conditions for the workers are good and there seems to be all round a better understanding between those who employ and those who work."

Another point in connection with the labor world which

Mr. Foster wished to particularly emphasize was the fact that May Day Socialist parades are neither organized nor supported by Trades and Labor Councils. These recognize the first Monday in September as the one day of the year dedicated to Labor.

Mr. J. E. Campeau, secretary and business agent of the Building Trade Council of Montreal declared that conditions for the various building trades were in excellent shape, and that with plenty of work ahead and no disputes pending regarding hours of work or of pay, he did not expect any trouble this season. Much had been done to improve labor conditions, Mr. Campeau said, by the friendly attitude of Builders' Exchanges, in acceding to the requests of cement finishers, stone cutters, electrical fitters and painters for better wages and improved working conditions.

Labor men generally believe that 1913 will be a banner one for them, and at present no strike of any moment darkens their horizon.

SHIPBUILDING AT MONTREAL.

THE Canadian Vickers Company have decided to go ahead with their Montreal plant at once. Located in Maisonneuve, their work will make the place alive with activity. They will begin almost immediately with the construction of their administrative offices and the establishment of a shipbuilding and repairing plant, according to a statement made by one of their officials recently. One big building has already been completed and equipped with machinery, and it is understood that several hundred thousand dollars will be spent on work to be undertaken.

The company has made application to the Montreal City authorities, regarding the homologated line of road on Notre Dame St. East, upon which their new offices will face.

The main works have been planned so that they will in no way interfere with the extension of the city streets down to the water front, and the general scheme involves machine shops, boiler and engine shops, storehouses, ship yards and a score or more of big structures necessary to the carrying out of their various enterprises. All the ground in the neighborhood of the floating dry dock has been cleared and leveled, and a member of the Vickers' organization states that they are only waiting now for the plans to reach them from England in order to proceed with construction.

The ship building slip will be started this summer, and while it is explained that the actual ship building plant will not be completed this year, every facility will be afforded and provision made for the repairing of vessels during the present season of navigation. The Harbor Commission are obliged to co-operate with the dry dock people by providing permanent improvement of their rail connection with the works, in addition to dredging the basin in which vessels will in future be launched.

From the foregoing it will be noted that despite the political feature, which is, of course, more or less relative to warship building, there is every evidence that the development of the shipbuilding and marine engineering industry towards the front rank of the manufacturing enterprises of Canada bids fair to make rapid progress. Machine tool builders are largely interested in this feature, opening up as it does, a new field for the disposal of their product, unsurpassed even by our railroad shops. As has been pointed out in these columns on previous occasions, there is both need and opportunity for the higher and larger achievement. that the shipbuilding industry will bring; we, therefore, express the hope that the near future will witness a like display of confidence in our country by others, as that exemplified by Vickers, Ltd.

INDUSTRIAL ^{AND} CONSTRUCTION NEWS

Establishment or Enlargement of Factories, Mills, Power Plants, Etc.; Construction of Railways, Bridges, Etc.; Municipal Undertakings; Mining News.

Engineering

Oshawa, Ont.—The Bowmanville Foundry Co. are looking for a location here for their plant. Mr. Redher is representing the company. The firm employ 150 men.

North Bay, Ont.—The contract for the new C. P. R. shops and terminals at this point, calling for an expenditure of \$350,000, will probably be awarded to Sherwood & Sherwood.

Brampton, Ont.—The Massey-Harris Co., Toronto, have purchased a farm of 185 acres here and plans will be prepared for the erection of a gasoline engine and separator works.

Eburne, B.C.—Letson & Burpee, machinists, 152 Alexander Street, will build new shops on Lulu Island, near here, at a cost of approximately \$20,000, and move entire plant to new location.

Brantford, Ont.—It has been denied here officially that the Keeton Motor Car Co. will be removed from Brantford. The company will, on the other hand, greatly increase the capacity of the plant.

Brantford, Ont.—The loss in the Pratt & Letchworth Co.'s fire recently was heavier than at first announced. It actually amounts to \$35,000, the greater part of which was due to loss of cores and patterns.

Toronto, Ont.—The Anthes Foundry Company have purchased five acres of land at Calgary, Alberta, on which to build a foundry. Plans have not been made yet, and we understand nothing will be done this year.

Brampton, Ont.—The Massey-Harris Co., manufacturers of farm implements, may establish a plant here to manufacture Deyo-Macey engines, made at present in Binghampton, N.Y., by a company which was bought out by the Massey-Harris Co.

Sault Ste. Marie, Ont.—The Algoma Steel Co. has completed plans for the erection of a cupola, 12 feet in diameter and 30 feet high. A contract for the steel plate work, house frame work, platform, bustle pipe and stacks was awarded the Riter-Conley Mfg. Co., Pittsburgh.

Victoria, B.C.—The C.P.R. is building large roundhouses and machine shops on

the old Songhees' Reserve. It is stated to be the intention of the Provincial Government to authorize almost immediately a commencement upon the comprehensive plan for the development of the terminal area, for which an appropriation of some \$350,000 has been made.

Calgary, Alta.—The Western Iron Manufacturers, Ltd., will soon commence operations. They will have an annual output of 200 well drilling machines, valued at \$150,000. This concern, which will employ about 35 men at the start, have a contract for three years with the Canadian Fairbanks-Morse Co. to manufacture all their well drilling machinery for Canada.

Fort William, Ont.—The Fort William plant of the Canadian Car and Foundry Co., Limited, will supply a good share of the \$85,000,000 worth of rolling stock required by the Canadian Northern and Grand Trunk Pacific Railways. According to the estimates of the two big railway systems, the Canadian Northern line will order cars, costing approximately \$50,000,000, and the Grand Trunk Pacific has made an appropriation for \$35,000,000 worth of rolling stock.

Port Arthur, Ont.—Port Arthur is rejoicing in the fact that Sir William Mackenzie has announced that financial negotiations are proceeding satisfactorily for the establishment of the huge steel plant here. Over a mile of waterfront has been set aside for the concern by the city. The cost of the undertaking has not been definitely announced, but a conservative estimate by men with expert knowledge places the amount in the vicinity of \$8,000,000.

Weyburn, Sask.—Representatives of the Cleveland Mfg. Co. were in Weyburn last week, and signified their intention of going ahead at once with the plant which that company proposes to erect here for the manufacture of stoves, gasoline engines and machine tools. The company claims that it will give employment to at least 200 men. The plant when all machinery is installed ready for operation will entail an expenditure of almost \$350,000.

Brantford, Ont.—A number of well-known Brantfordites are making application to the Ontario Legislature for a charter for \$50,000 to start an iron foundry here. The final selection for the site of the new factory has not yet been decided upon. Mr. Carl Smith,

who recently resigned from the position of purchasing agent of the Pratt & Letchworth Company, and Mr. Rowell, of the Auto-Cycle Company, are especially interesting themselves in the formation of the new company. The stock is being rapidly taken up.

Ottawa, Ont.—Details of the new \$500,000 gas plant which the Ottawa Gas Co. is building in Ottawa East this spring, show that the holder building will be 150 feet in diameter, and will have a capacity of 1,500,000 cubic feet of gas. The retort house, where the gas is manufactured, will be 50 x 150 feet and of three storeys. The coal sheds will be from 200 to 250 feet long by 61 feet wide, with steel conveyors and carriers extending to all parts of the yard. There will be a plant for the extraction and manipulation of tar and ammonia situated in half a dozen additional buildings, including a boiler house with a 120-foot chimney.

Calgary, Alta.—A steel frame building is being built by the Pioneer Tractor Co. It is 580 feet long, and will be used for assembling the various kinds of farm machinery which the firm will offer for sale in the three Prairie Provinces. The plant is located four miles east of Calgary close to the G.T.R. line.

The Pioneer Tractor Co. are employing 300 men during the first year of operation, and they expect to turn out the first tractor for the market some time this fall. Work on their plant is progressing rapidly, and in addition to the large assembly shops, there will be three others.

Electrical

London, Ont.—The London Electric Co. will shortly install new turbine machinery and will declare electric war on the Hydro-Electric Commission. It is reported that they will reduce their rates.

Toronto, Ont.—The City Hydro-Electric Commission and the works department have reached a settlement of the disputed account for power at the waterworks. This was for \$94,000, and the Commission has agreed to reduce it by one-third.

Sydney, N.S.—The Maritime Coal, Railway & Power Co. will make large extensions to the power plant at Chig-

necto, N.S., and will electrify the colliery plant at Joggins Mines, to meet the increased demand for coal and electric power.

New Westminster, B.C.—The C.P.R. have fixed their first division point to the North-west at Boston Bar, and are making provision for supplying light, water and power to the place. A generating station will be built and 500 H.P. developed for use in shops and terminals and for lighting the town.

South Vancouver.—The British Columbia Electric Railway Co. will erect a new \$90,000 sub-station in South Vancouver to be built of reinforced concrete, with a gallery for the switching apparatus. The equipment will include three motor generator sets of 1,000 kilowatts capacity each and a transforming equipment of 7,000 kilowatts capacity. The railway company has also promised to make considerable extensions to its trackage if the municipality agrees with its conditions.

North Bay, Ont.—A new organization known as the United Board of Trade of New Ontario, has been organized at Sudbury, to include the Boards of Trade of Sudbury, Sault Ste. Marie, North Bay, Sturgeon Falls, Callender, Blind River, and Thessalon. One of the first matters taken up by the new organization was the question of interesting the Ontario Hydro-Electric Commission in developing the water powers of the north, and the meeting endorsed a proposal to hold a conference with the commission on the subject at an early date.

Toronto, Ont.—It is understood from press reports that interests connected with the Canadian Northern Railway Co. have acquired \$400,000 of the bonds of the Chatham, Wallaceburg and Lake Erie Radial Railway, which gives them control of that road. Its equipment includes three electric locomotives and seven double track passenger cars, as well as about 20 freight cars. One of the locomotives is rated at 400 horsepower, and is capable of hauling a train of 25 cars. Each of the other locomotives is 200 horse-power.

The company's power house, where energy is generated by steam, has now been taken over by the Chatham Gas Co.

Water-Works

Cowansville, Que.—By-law No. 118 to authorize the Council to expend \$3,000 on a pumping station and filtration plant will be voted on by the ratepayers on May 10th.

Collingwood, Ont.—Chairman Caslake of the Water and Light Commission re-

cently informed the town council that the mountain water scheme would cost, including sand filter, pumps, pipes, laying of pipes, etc., \$150,000, or with heavy standard pipes throughout, \$223,150. A plan has also been prepared by Chipman & Power, engineers, Toronto, for extending the water system at a cost of \$75,000. No decision has yet been come to.

Municipal

Co. Salt, Ont.—Fire on May 1, destroyed the public incinerator. The loss is \$7,000, with no insurance.

Toronto, Ont.—The Ontario Government will spend \$100,000 on new roads around Hearst. Some of the roads cut last year will be graded this year.

Vernon, B.C.—The Kelowna Board of Trade have re-opened the matter of a road from Kelowna to Naramata with the local board, and are of the opinion the road could be built for \$75,000.

Salmon Arm, B.C.—The following by-laws were submitted to the burgesses on May 3:—To raise \$1,500 re grading school grounds; \$4,400 re debt incurred; \$22,000 re cost of waterworks; \$42,000 re construction of sewerage system; \$15,000 re macadamizing of streets; \$1,600 re transfer of land, and \$45,000 re waterworks.

Edmonton, Alta.—Active work has been begun here upon a construction programme, involving the expenditure of more than \$33,000,000, as follows: Public and private buildings, \$20,000,000; municipal work, \$8,000,000; railroad improvements and betterments, \$5,250,000. The first work undertaken for the city consists of 500,000 square yards of paving and several miles of sidewalks and sewers. In addition, \$200,000 will be expended by private interests in building ten miles of street railway extensions, to be turned over to the city.

Wood-Working

Rosedale, B.C.—The Fernridge Lumber Co. will install three shingle machines.

Golden, B.C.—The sawmill of the G. B. Ferguson Lumber Co. at Six Mile Creek will commence cutting in a few days. J. F. Coates is at present installing the steam plant.

Preston, Ont.—On April 30 fire broke out at the Gillies' planing mills, near the Grand Trunk station, and, before the firemen could get it under control, considerable damage had been done to the building and contents.

Building Notes

Fort William, Ont.—The construction of a warehouse, 5 storeys high, costing \$78,000, will be commenced in a week or two by Cameron & Heap.

London, Ont.—John Hayman & Sons, Limited, have commenced work on an apartment building costing \$60,000. They have also commenced work on the new Aberdeen School, costing \$75,000.

Toronto Ont.—The general contract for the new Technical School was signed up May 1st. The contractors are Norcross Bros., of Worcester, Mass., and the contract price is \$1,082,700.

Quebec, Que.—Work on the foundation of the new Quebec Arena, at Victoria Park, has been started, and the erection of steel work will begin in July. The contract for latter has been awarded to the Dominion Bridge Co.

Saskatoon, Sask.—The Standard Securities Co., with a capital of \$300,000 have been incorporated to contract for local construction work in Saskatoon instead of having it go to outside contractors. Mayor F. E. Harrison is one of the directors.

Victoria, B.C.—One of Victoria's finest commercial buildings, the Belmont Block, which represents an investment of at least \$700,000, is practically completed. The Norton Griffiths Steel Construction Co. are engaged now in administering the finishing touches.

Toronto, Ont.—It is stated on reliable authority that the Statler Hotel Co., of Buffalo, will build a hotel, having eight hundred rooms on a site at the north-eastern corner of Front and Bay Streets. It is understood that G. B. Posts & Sons, architects, New York, are preparing the plans for the new structure.

General Industrial

Fort William, Ont.—The Superior Brick and Tile Co., of Rosslyn, have commenced to turn out brick and tile.

Weston, Ont.—An addition consisting of a three-storey moulding shop and a nickel plating shop will be erected by the Moffatt Stove Co., at a cost of \$250,000.

St. Catherines, Ont.—J. Melvin Gayman & Co. are promoting a canning and preserve factory at Dunnville, Ont. An option on a 55-acre site has been secured.

Dundas, Ont.—The Cockburn Lumber and Concrete Co., Ltd., with a capital of \$100,000, are preparing plans for a new plant. A new style of cement brick will be made, also sewer pipes. J. W. Cockburn is president.

Toronto, Ont.—The W. J. Hewitson Co., Ltd., manufacturers of children's and misses' shoes, will move their entire plant to Montreal within a short time.

Winnipeg, Man.—Fire destroyed the warehouse and contents of the Continental Oil Co., Elmwood, on Sunday, April 27th. The loss of \$30,000 is covered by insurance.

Niagara Falls, Ont.—The Goodrich Rubber Co., manufacturers of automobile tires and rubber goods, with a large plant at Akron, Ohio, has decided to build its Canadian plant in this city.

New Lowell, Ont.—The grain elevator of Mr. J. A. Bell was destroyed by fire on Friday, April 25th. The loss of \$6,000 is partly covered by insurance. He will replace it by a 30,000 bushel elevator.

Fort William, Ont.—The Fort William Elevator Co. have applied for tax exemption on an elevator which they propose to erect costing \$700,000, and with a capacity of 750,000 bushels. David Horne represents the company.

Prince Albert, Sask.—Owing to a disagreement between the city and the Great West Iron and Chain Co., of which D. B. Hanna and F. H. Phipper of the C.N.R. are directors, the latter Co. will close down their factory. The trouble is over a bond guarantee.

Toronto, Ont.—According to Mr. Stanley Thompson, real estate agent, one of the largest news print manufacturing concerns in the United States is looking for a factory site in Toronto as a result of their product being placed on the free list by the Wilson Government.

Peterborough, Ont.—Representatives of the Vermont Marble Co. have been in the city arranging for the construction of their new factory in East City. Mr. Davies, engineer for the company was with the party. It is understood that building operations will be commenced within the next few months.

Railways—Bridges

Hamilton, Ont.—The Imperial Construction Co. have given the right to build a new line between Hamilton and Toronto.

Medicine Hat, Alta.—By a unanimous vote, the city council has decided to submit to a vote of the people an agreement with the Montreal Engineering Co. for the installation of a street railway in Medicine Hat on May 22.

New Westminster, B.C.—The B.C. Electric Railway are anxious to build

a line to Port Moody, but cannot do it now, owing to the condition of the money market and the difficulty of securing equipment for extensions already built.

New Westminster, B.C.—About 68 cars loaded with steel which will be used on the different bridges between here and Kamloops are lying at the Company's yards at Port Mann. These cars keep arriving every day from Eastern points.

Montreal, Que.—It is stated that in anticipation of the completion of the Canadian Northern line to Montreal within a year, the company is planning the immediate erection of six new large grain elevators between Port Arthur and Winnipeg, and another series of elevators between Edmonton and Winnipeg.

Edmonton, Alta.—Arrangements were made at a meeting of the directors of the Edmonton, Stony Plain and Wabamun Electric Railway Co., headed by George P. Dobson to clear and grade five miles of right-of-way from the western city limits. It is announced that cars will be in operation at the end of the summer.

Winnipeg, Man.—A deputation of St. Boniface aldermen will approach Public Utilities Commissioner Robson with regard to the new Provencher bridge, plans of which will be submitted for approval. It has been decided to pay \$10,000 to contractors McGoogal and McDonald, as the first payment on the construction work done for the new bridge.

Thorold, Ont.—At a meeting of the Thorold township council held at Allsburg recently, the N.S. & T. Railway Co. applied for a franchise to lay more track in the township. The proposed new route will be from Thorold to Lock 25, then south along the stone road to Allsburg. That part of the work as far as Lock 25 will be commenced immediately, further extensions being made later.

Dunville, Ont.—Jas. A. Ross of Wellandport, representing the Dunville, Wellandport and Beamsville Electric Railway, appeared before the Dunville Town Council last week, and asked for another extension of one year's time for the completion of the road, which was granted. He stated that there is every prospect of having the line completed and in full operation this fall. Late last fall, the remaining \$200,000 of the bonds were sold to Toronto brokers, thus enabling the Company to complete the railway between Dunville and St. Anns.

Marine

Halifax, N.S.—The city will seek legislation to extend Oaklands Road west to the shore of the North West Arm.

Kingston, Ont.—The sale of the Hepburn line of steamers, plying from Charlottetown and the Bay of Quinte to Quebec, to a Toronto company headed by Aemilius Jarvis, is reported, with J. A. Goodearle, of Toronto, formerly of Kingston, as manager.

Fort Erie, Ont.—Frank Fix, of the firm of Fix Bros., who are operating ferries being used by the Fort Erie and Buffalo Ferry Co., is desirous of purchasing or chartering a suitable ferry for the summer traffic. He recently purchased the steamer Favorite, capable of handling 15 automobiles and 500 passengers.

Montreal, Que.—The Harbor Commissioners have decided to construct a new wall on Mackay pier at a cost of \$100,000, and will extend the King Edward and the Jacques Cartier piers by 250 feet. The Racine pier will also be raised to high level. The reconstruction of the superstructure in concrete of the Alexandra, King Edward and Jacques Cartier piers will be commenced this year.

St. John, N.B.—The tug G. S. Mayes, built by the Beaver Bridge Co. was launched on Monday, April 25th. She is 92 ft. long, 22 ft. beam and 11 ft. deep. The new tug will use the engines and machinery of the Dirigo which are now being rebuilt by Messrs. James Fleming & Sons at the Phoenix Foundry. A modern winch for handling the hawsers, steam steering gear and other modern devices will be installed.

Toronto, Ont.—Work was commenced last week on the construction of the floating dry dock which is to be situated near the Polson Iron Works. Excavating teams were removing earth and cutting the slip. The work should be finished by October. The dock has been designed to carry a vessel weighing 5,400 tons. Following are the dimensions of the dock: Length over all, 330 feet; total width, 100 feet; length of deck, 300 feet; total weight, 2,000 pounds. When the new contrivance is ready for service, local vessels will not have to go to Kingston for repairs.

Contracts Awarded

Fort William, Ont.—The city have awarded a contract for a 500 K.W. generator costing \$11,000, to the Can. General Electric Co.

Ottawa, Ont.—Contract for building work shops, costing \$4,000, for Trudel & McAdam, 309 Sparks Street, has been let to Geo. Crain, Clemow Ave.

Montreal, Que.—The contract for the Toronto Stratford line of the C.N.R. has

been awarded to Mr. William Mackenzie, a cousin of Sir William Mackenzie.

Edmonton, Alta.—Contracts amounting to \$1,000,000 have been awarded to H. C. Ulen of Chicago, for sewer construction in Edmonton this season. Work is to begin at once.

Winnipeg Man.—The Winnipeg city authorities have awarded contracts in connection with the new reservoir on Logan Avenue as follows: Reinforced steel, Steel Co. of Canada, \$27,116.65; cement, the Canada Cement Co.

Fort William, Ont.—Upon recommendation of the Board of Works, the tender of the United States Steel Products Company to supply bolts and spikes for the street railway extension at a cost of \$30,000, was accepted.

Fort William, Ont.—The city has awarded the contract for 7,000 feet 18-inch pipe to the Canada Iron Corporation. The price tendered was \$25,167. The company has a plant in Fort William, employing altogether 400 men.

Montreal, Que.—With the approval of the Electric Service Commission, the Board of Control will accept the tender of G. M. Gest, contractor, Montreal, for the construction of the underground conduits along St. Catherine Street, from Papineau Avenue to Guy Street. The contract price of the work is \$217,000, and, the time specified is six months.

Ottawa, Ont.—A \$130,000 contract for lumber required in connection with the Hudson Bay Railway was let by the Government, on May 3. The following firms shared in the contract:—The Atlantic Lumber Co., Toronto; the Musgrave Lumber Co., Halifax; and the Long, Bell Lumber Co., Philadelphia; the contract with the latter Company being for southern pine.

Trade Gossip

The Norwood Garage, cor. of Horace and St. Joseph Streets, Norwood, Man. is erecting a new machine shop, 62 x 55 feet, for general repairs.

The Dominion Iron and Steel Co., Ltd., have opened a warehouse near the merchants' Mutual Dock, at the foot of York St., Toronto. Mr. Max Morell is in charge.

Nova Scotia Steel & Coal Co.—The April output of the Nova Scotia Steel & Coal Co. is the best since the beginning of the year. Ore mined, 55,000 tons; coal mined, 68,300 tons; pig iron made, 7,580 tons; steel made, 7,300 tons.

The Dominion Nickel Copper Co., Sudbury, Ont., have just bought from

the A. R. Williams Machinery Co., for their smelter: One Cleveland 36 x 36-in. x 6-ft. planer, 1 28-in. W. F. & John Barnes drilling machine, 1 42-in. x 22-ft. engine lathe, 1 20-in. x 20-ft. engine lathe, 1 48 x 200-in. No. 7 Caldwell hydraulic wheel press, 1 Thos. W. Ward plate bending rolls, 2 Williams pipe machines, 1 26-in. throat punch and shear, 1 5-ft. Dresses Machine Tool Co. radial drill, 1 Hilles & Jones flanging clamp, 1 Landis Machine Co. bolt cutter.

Personal

Geo. Smith, engineer, of Lindsay, Ont., has been appointed town engineer of Midland, Ont.

City Engineer J. H. Kilmer has moved his family and effects from Vancouver and intends making Port Coquitlam his permanent residence.

J. C. Nash has been appointed assistant engineer to Engineer Sifton of the Hydro-Electric system. He was recently employed by the Westinghouse Co.

L. D. Shafner of the Coquitlam Shipbuilding and Marine Railway Co. will present to the Board of Trade the original model of the first ship ever built on the Fraser River.

T. P. Howard, managing director of the Phoenix Bridge and Iron Works, has been nominated for the vice-presidency of the Canadian Manufacturers' Association.

B. W. Pharis, formerly superintendent of the Canada Foundry Co., Toronto, Ont., has been appointed foundry superintendent of the Erie Engine Works, Erie, Pa.

F. R. Elbert has resigned as superintendent of Bowes, Jamieson, Ltd., iron founders, Hamilton, Ont., and has accepted a position with the Ohio Foundry & Mfg. Co., Stenbenville, O.

E. B. Rouse, formerly foundry superintendent of the casting shop operated by the Canadian Fairbanks Co., Sherbrooke, Que., has been appointed superintendent of the Lawrence Foundry Co., Montreal.

B. G. Slaughter, Jr., has resigned as chief engineer and superintendent of construction, the Tennessee Copper Co., Copperhill, Tenn., in order to become mechanical superintendent of the Canadian Copper Co., Copper Cliff, Ont.

T. P. Marshall, the retiring superintendent of stations of the Toronto Electric Light Co., was waited on at his home, 225 Booth Avenue, on Thursday last, by a deputation from the operating

department, who presented Mr. and Mrs. Marshall with a beautiful leather couch.

S. Fortner, a foreman at the London Bolt and Hinge Works, received a club bag and gold-headed cane from the employees on April 30. Mr. Fortner has been in the employ of the works for a number of years, and was highly esteemed by all who knew him. He is leaving for the West.

W. L. Richardson, B.A., superintendent of manual training in the Toronto Public schools was presented at the City Hall, on April 29th, with a handsome club-bag on the eve of his departure to take up the position of Director of Industrial Education in the City of Edmonton.

Frank Reid, who has had charge of the foundry department of the Northern Engineering Company, Fort William, Ont., left May 2 for St. Catharines, Ont., where he will engage in business for himself. Mr. Reid before joining the Northern Engineering Company was employed by the Copp's foundry.

F. P. Gutelius has been appointed Commissioner of the Intercolonial Railway, the Government having decided to dissolve the present board of management and put the direction of the road in the hands of a single commissioner. Mr. Gutelius was formerly with the C. P. R. at Montreal. His headquarters will be at Moncton, N. B.

Miss Cecelia MacMillan, for the past two years on the staff of stenographers in the engineering department of the Dominion Iron and Steel Company, Sydney, N.S., has resigned from the staff. Miss MacMillan before leaving was presented with a handsome gold bracelet set with diamonds by the ladies and gentlemen of the engineering department.

W. R. Sweaney, until recently acting general manager of the Toronto Hydro-Electric commission, has been engaged by the Toronto Electric Light Co. The appointment was made a few days ago by General Manager Fleming of the Toronto Railway and Electric Light systems. Mr. Sweaney will be sales manager, and succeeds Parker Kemble, who recently went Cincinnati.

H. H. Couzens, general manager and electrical engineer of the Corporation of Hampstead, London, England, has been appointed general manager of the Toronto Hydro-Electric system. Mr. Couzens has had a wide experience in construction work, in the complete installation of electrical plants, having held important positions with the Corporations of Taunton, Bristol, West

Ham and Hampstead. He is due here in a few weeks.

R. A. Ross, acting manager of the Toronto Hydro-Electric System, has made the following appointments on the Hydro staff:—Percy E. Hart, as electrical engineer; J. Orr, general superintendent; George Stevenson, general inspector; Geo. Schwanger, as engineer of distribution; J. M. McNeilly, superintendent of meter department; R. J. Lee, contract agent; J. B. Kitchen, engineer of operation department, and G. Devlin, as head salesman.

Obituary

David Reid, superintendent of J. B. Prescott and Sons' foundries, Webster, Mass., died at his home on May 1, aged 42 years. He came to Webster three years ago from Toronto.

H. Moulsworth Price died at Mont Morency Falls, Que., on April 29th at the age of 66. For some time he was in the banking business but about 25 years ago went into the pulp and lumber business.

Isaac Sargent, who for 40 years has conducted a contracting business and lumber mill in London, Ont., died at his home recently. He was 72 years of age. Mr. Sargent was born in Devonshire, England, and came to Canada over 40 years ago. He commenced business as a contractor and afterwards established a planing mill, a horse on a treadmill being his first source of power. Since that time he had developed an extensive business, and operated a large plant in London.

Alexander Sangster, senior member of the firm of Larkin & Sangster, who have held large Government contracts in the United States and Canada, died at his home in St. Catharines on Thursday, April 25, after being an invalid for a year following a stroke of paralysis. The firm is now carrying on a contract on the Erie Canal, involving the expenditure of several million dollars. Mr. Sangster was born in Scotland residing in Thorold for several years before removing to this city.

E. B. Wingate C.E., died at the City Hospital Hamilton, Tuesday, April 22, in his fifty-seventh year. He had been ill for a long time and about a week ago was taken to the hospital. The deceased was recognized as a civil engineer of exceptional ability. He came to Hamilton about twenty years ago to do engineering work on the T. H. & B. Railway, and had to surmount great difficulties in the task. Following this, he was appointed city engineer, which position he held for a few years. Latterly he has

been taking private commissions. He was a native of the United States. He is survived by his wife and one daughter, and one brother residing in Philadelphia.

New Incorporations

Chicago Bridge & Iron Co., incorporated Toronto, to contract for and build bridges, roads, etc. Capital \$35,000.

Southern Ontario Gas Company, Ltd., incorporated at Toronto. Capital \$15,000,000. Incorporators: J. Harley, E. Sweet, A. M. Harley, O. M. Hall and J. Graham, all of Brantford, Ont.

MacDonald-Meerbeck, Ltd., incorporated at Toronto, as manufacturers of bodies for automobiles. Capital \$40,000. Incorporators: A. Meerbeck, F. E. MacDonald, F. H. C. MacDonald, T. A. Woods and W. J. Boland, all of Toronto,

The Toronto Clay Products Co., Ltd., incorporated at Toronto to manufacture and deal in bricks, sewer pipes, etc. Capital \$300,000. Incorporators: J. B. Ferguson, C. J. Quarrington, G. F. DeWitt, V. Delawarr and G. G. Plaxton, all of Toronto, Ont.

Mississauga Pulp and Paper Co., Ltd., incorporated at Ottawa, with a capital of \$2,500,000 to manufacture pulp and paper. Incorporators: John F. MacGregor, William H. Walter, Joseph Edward Riley, Harry Riley, Everett Bristol, all of Toronto.

Pembroke Transportation Co., Ltd., incorporated at Ottawa, with a capital of \$40,000, to construct steamboats. Incorporators: William L. Hunter, James C. Hunter, John W. Smith, William H. Bromley, Edward A. Dunlop, Pembroke, Ont.; Christopher L. McCool.

Lavoie Motor, Ltd., incorporated at Ottawa to manufacture and deal in all kinds of motors and engines, automobiles, trucks, etc. Capital, \$1,000,000. Incorporators—A. J. Lavoie, H. S. Ross, O. F. Shearer, E. M. Leet and F. Salmon, all of Montreal, Que.

The Consolidated Building and Supply Co., Ltd., incorporated at Toronto to carry on the general business of a land and building company. Capital \$250,000. Incorporators: A. J. Bailey, R. E. McCuaig, T. F. McFarlane, Henry Roade and J. A. Cameron, of Toronto.

The Electric Repair & Contracting Co., Ltd., incorporated at Ottawa, with a capital of \$50,000, to manufacture electrical goods. Incorporators: George Matthews, of Westmount, Robert Urquhart, Ulric A. Leduc, Ralph F. Stockwell, Edson G. Place, of Montreal.

The Neustadt Furniture Company, Ltd., incorporated at Toronto, to manu-

facture and deal in chairs and furniture. Capital \$20,000. Incorporators: J. Wells, J. Weber, C. Derbecker, A. Weinert, A. J. Dunemann, D. Lippert, and J. Molitor, all of Neustadt, Ont.

The Hamilton Cadollac Motor Co., Ltd., incorporated at Toronto as manufacturers and dealers in automobiles and automobile accessories. Capital \$40,000. Incorporators: J. Dixon, F. R. Newberry, J. A. Sauriol, J. Crooks, and F. F. Dalley, all of Hamilton, Ont.

The Phoenix Bridge and Iron Works, Ltd., incorporated at Ottawa, as buyers and sellers of iron and steel and other structural materials. Capital, \$1,500,000. Incorporators—E. Languedoe, E. R. Parkins, A. C. Calder, Wm. Taylor and J. M. Montle, all of Montreal, Que.

London Pressed Brick and Tile Co., Ltd., incorporated at Ottawa to manufacture and deal in building material of all kinds. Capital, \$100,000. Incorporators—C. S. Parker, J. M. McEvoy, E. Scateherd, H. E. Anderson and A. E. Dufton, all of London, Ont.

Malone Moulding and Framing Co., Ltd., incorporated at Ottawa to manufacture and deal in mouldings, frames, cabinets, etc. Capital, \$50,000. Incorporators—F. J. Laverty, C. A. Hale, J. Dunlop and J. Trudel, all of Montreal, Que, and J. W. Blair, of Westmount, Que.

Canadian Allis-Chalmers, Ltd., incorporated at Ottawa, to take over the business of the Allis-Chalmers-Bullock Co. Capital, \$500,000. Incorporators—B. Haddy, Wm. H. Nesbitt, G. Logan, J. Murrode, J. A. Bremner, A. E. Guest and Wm. McKennedy, all of Toronto, Ont.

Motor Traction of Canada, Ltd., incorporated at Ottawa, to manufacture and deal in all kinds of motor trucks and vehicles at Calgary. Capital, \$250,000. Incorporators—Col. J. Walker, R. C. Jackson, T. Henderson, G. Zimmerman, and Capt. H. R. Pease, all of Calgary, Alta.

Montreal-Valleyfield and Soulanges Navigation Co., Ltd., incorporated at Ottawa to build and deal in ships and barges of all kinds. Capital, \$20,000. Incorporators—A. E. de Lorimier, E. H. Godin, H. E. Morier and E. Charette, all of Montreal, Que, and J. L. Girouard, of Outremont, Que.

Kelsey Wheel Co., Ltd., incorporated at Toronto, to manufacture and sell automobile wheels and other motor accessories. Capital, \$150,000. Incorporators: John Kelsey, W. H. Ducharme, and B. J. Fox, all of Detroit, Mich., and Malcolm G. Campbell, and O. E. Fleming, both of Windsor, Ont.

SELECTED MARKET QUOTATIONS

Being a record of prices current on raw and finished material entering into the manufacture of mechanical and general engineering products.

PIG IRON.

	Per Ton.	
Foundry No. 1 and 2, f.o.b., Midland	\$19 00	\$19 50
Gray Forge, Pittsburg	16 15	
Lake Superior, charcoal, Chicago	18 00	
	Mont'l. Tor'to.	
Canadian f'dry, No. 1..	\$21 00	\$20 00
Canadian f'dry, No. 2..	20 50	19 50
Middlesboro, No. 3....	23 50	23 50
Summerlee, No. 2	25 00	26 50
Carron, special	25 00
Carron, soft	25 00
Cleveland, No. 1	24 25	25 00
Clarence, No. 3	23 75	24 50
Jarrow	25 50	
Glegarnock	26 00	
Radnor, charcoal iron.	30 00	34 50
Ferro Nickel pig iron (Soo)	25 00	

BILLETS.

	Per Gross Ton.	
Bessemer billets, Pittsburgh ...	\$28 50	
Open hearth billets, Pittsburgh.	29 00	
Forging billets, Pittsburgh.....	36 00	
Wire rods, Pittsburgh	30 00	

FINISHED IRON AND STEEL.

Per pound to large buyers:

	Cents.
Common bar iron, f.o.b., Toronto..	2.10
Steel bars, f.o.b., Toronto.....	2.20
Common bar iron, f.o.b., Montreal.	2.15
Steel bars, f.o.b., Montreal.....	2.25
Bessemer rails, heavy, at mill....	1.25
Iron bars, Pittsburgh	1.70
Steel bars, Pittsburgh, future	1.40
Tank plates, Pittsburgh, future...	1.45
Beams, Pittsburgh, future	1.45
Angles, Pittsburgh, future	1.45
Steel hoops, Pittsburgh	1.60

Toronto Warehouse f.o.b., Toronto.

	Cents.
Steel bars	2.30
Small shapes	2.40
Warehouse import, freight and duty to pay:	Cents
Steel bars	1.95
Structural shapes	2.05
Plates	2.05
Freight, Pittsburgh to Toronto:	
18 cents carload; 21 cents less carload.	

BOILER PLATES.

	Mont'l. Tor'to.	
Plates, ¼ to ½-in., 100 lbs.	\$2.35	\$2.35
Heads, per 100 lbs.....	2.65	2.95
Tank plates, 3-16 in.	2.60	2.60
Tubes, per 100 ft., 1 inch	9.00	8.50
" " 1¼ in.	9.00	8.50
" " 1½ "	9.00	9.00
" " 1¾ "	9.00	9.00
" " 2 "	8.75	8.75
" " 2½ "	11.50	11.50
" " 3 "	12.00	12.00
" " 3¼ "	13.75	13.75
" " 3½ "	15.00	15.00
" " 4 "	18.00	18.00

BOLTS, NUTS AND SCREWS.

	Per cent.
Stove bolts	80 & 7½
Machine bolts, ¾ and less	65 & 5
Machine bolts, 7-16.....	57½
Blank bolts	57½
Bolt ends	57½
Machine screws, iron, brass	35 p c.
Nuts, square, all sizes.....	4c per lb off
Nuts, Hexagon, all sizes..	4¼ per lb off
Flat and round head....	35 per cent.
Fillister head	25 per cent.
Iron rivets	60, 10, -0 off
Wood screws, flathead, bright	85, 10 p c off
Wood screws, flathead, brass	75, 10 p c off
Wood screws, flathead bronze	70, 10 p c off

National-Acme "Milled Products."

Sq. & Hex Head Cap Screws	65 & 10%
Sq. & Hex Head Cay Screws	65 & 10%
Rd. & Fil. Head Cap Screws	45-10-10%
Flat & But. Head Cap Screws	40-10-10%
Finished Nuts up to 1 in. ..	75%
Finished Nuts over 1 in. ..	72%
Semi-Fin. Nuts, up to 1 in....	75%
Semi-Fin. Nuts over 1 in....	72%
Studs....	65%
Discounts f.o.b., Montreal.	

WROUGHT IRON PIPE.

The following are Toronto jobbers' discounts on pipe in effect from April 21, 1913:

	Standard	Buttweld Black Gal.	Lapweld Black Gal.
¼ ¾ in.	62	47
½ in.	68	58
¾ to 1½ ...	71½	61½	68½ 58½
2 in.	71½	61½	68½ 58½
2½ to 4 in. ..	71½	61½	70½ 60½
4½ to 6 in.	71½ 61½
7, 8, 10 in.	66 54

X Strong P. E.

¼, ⅜, ½ in. ...	56½	46½
¾ to 1½ in. ...	67½	57½
2 to 3 in.	68½	58½
2½ to 4 in.	65	55
4½ to 6 in.	64	56
7 to 8 in.	55	45

XX Strong P. E.

½ to 2 in.	43	33
2½ to 4 in.	43	33

PRICES OF WROUGHT IRON PIPE.

Standard. Nom. Diam.	Price per ft.	Extra Strong. Sizes Ins.	Price per ft.	D. Ex. Strong. Size Ins.	Price per ft.
½ in	\$.05½	½ in	\$.12	½ in	\$.32
¾ in	.06	¾ in	.07½	¾ in	.35
⅝ in	.06	⅝ in	.07½	1 in	.37
½ in	.08½	½ in	.11	1¼ in	.52½
¾ in	.11½	¾ in	.15	1½ in	.65
1 in	.17½	1 in	.22	2 in	.91
1¼ in	.23½	1¼ in	.30	2½ in	1.37
1½ in	.27½	1½ in	.36½	3 in	1.86
2 in	.37	2 in	.50½	3½ in	2.30
2½ in	.58½	2½ in	.77	4 in	2.76
3 in	.76½	3 in	1.03	4½ in	3.26
3½ in	.92	3½ in	1.25	5 in	3.86
4 in	1.09	4 in	1.50	6 in	5.32
4½ in	1.27	4½ in	1.80	7 in	6.35
5 in	1.48	5 in	2.08	8 in	7.25
6 in	1.92	6 in	2.86
7 in	2.38	7 in	3.81
8 in	2.50	8 in	4.34
8 in	2.88	9 in	4.90
9 in	3.45	10 in	5.48
10 in	3.20
10 in	3.50
10 in	4.12

IRON PIPE FITTINGS.

Canadian malleable, 40 per cent.; cast iron, 65; standard bushings, 70; headers, 60; flanged unions, 65; malleable bushings, 65; nipples, 75; malleable, lipped unions, 65.

COKE AND COAL.

Solvay Furnace Coke	\$5.25
Solvay Foundry Coke	6.50
Connellsville Furnace Coke	5.25
Connellsville Foundry Coke	5.75
Yough, Steam Lump Coal	3.83
Penn. Steam Lump Coal	3.63
Best Slack	2.95
All net ton f.o.b. Toronto.	

OLD MATERIAL.

	Tor'to.	Mont'l.
Copper, light	\$12 05	\$11 00
Copper, crucible	15 00	13 50
Copper, uncre'bled, heavy	13 05	12 50
Copper wire, uncre'bled..	13 05	12 50
No. 1 machine compos'n..	12 00	11 00
No. 1 comps'n turnings..	10 00	10 00
New brass clippings	9 15	9 10
No. 1 brass turnings	8 30	7 75
Heavy lead	3 25	3 25
Tea lead	3 00	2 75
Scrap zinc	4 00	3 75

Dealers' purchasing prices.

METALS.

Prices in cents per pound:

	Mont'l.	Tor'to.
Lake copper	16.25	16.25
Electrolytic copper	16.25	16.25
Spelter	6.00	6.10
Lead	4.70	5.50
Tin	52.00	52.00
Antimony	10.00	9.75
Aluminum	23.00	21.00

SMOOTH STEEL WIRE.

No. 6-9 gauge, \$2.35 base; No. 10 gauge, 6c extra; No. 11 gauge, 12 extra;

No. 12 gauge, 20c extra; No. 13 gauge, 30c extra; No. 14 gauge, 40c extra; No. 15 gauge, 55c extra; No. 16 gauge, 70c extra. Add 60c for coppering and \$2 for tinning.

Extra net per 100 lb.—Spring wire; bright soft drawn, 15c; charcoal (extra quality), \$1.25.

SHEETS.

	Mont'l.	Tor'to.
Sheets, black, No. 28....	\$2 85	\$3 00
Canada plates, ordinary, 52 sheets	2 80	3 00
Canada plates, all bright.	3 70	4 15
Apollo brand, 10¾ oz. (American)	4 30	4 20
Queen's Head, 28 B.W.G..	4 50
Fleur-de-Lis, 28 B.W.G..	4 20
Gorbal's Best Best, No. 28	4 45
Viking Metal, No. 28....	4 40

NAILS AND SPIKES.

Standard steel wire nails, base	\$2 40
Cut nails	\$2 60	2 65
Miscellaneous wire nails..	75 per cent.	
Pressed spikes, 5/8 diam., 100 lbs.	2 85

FINE STEEL WIRE.

Discount 25 per cent. List of extras. In 100-lb. lots: No. 17, \$5; No. 18, \$5.50; No. 19, \$6; No. 20, \$6.65; No. 21, \$7; No. 22, \$7.30; No. 23, \$7.65; No. 24, \$8; No. 25, \$9; No. 26, \$9.50; No. 27, \$10; No. 28, \$11; No. 29, \$12; No. 30, \$13; No. 31, \$14; No. 32, \$15; No. 33, \$16; No. 34, \$17. Extras net. Tinned wire, Nos. 17-25, \$2; Nos. 26-31, \$4; Nos. 30-34, \$6. Coppered, 75c; oiling, 10c.

MISCELLANEOUS.

	Cents
Putty, 100 lb drums	\$2.70
Red dry lead, 560 lb. caaks, per cwt.	6.00
Glue, French medal, per lb	0.10
Glue, 100 flake	0.11
Tarred slaters' paper, per roll...	0.95
Motor gasoline, single bbls., gal..	24½
Benzine, per gal.	23½
Pure turpentine	64
Linseed oil, raw	58
Linseed oil, boiled	61
Plaster of Paris, per bbl.	2.10
Plumbers' Oakum, per 100 lbs....	3.25
Pure Manila rope	17

The General Market Conditions and Tendencies

This section sets forth the views and observations of men qualified to judge the outlook and with whom we are in close touch through provincial correspondents.

Montreal, May 5, 1913.—After May Day has passed and labor has had its fling normal conditions again rule. The quietude of the past week was only disturbed by the voice of the Socialist in the parades, and the echoes of it are evidenced in the dullness of business. Moving and disruption amongst many business houses and those who are employees caused a break of no small proportions in the fabric for the week. However, from the machinery brokers comes the good news that, while not over busy at the moment, they have some big railway business coming forward. No one likes to confess inactivity and nobody will.

Pig Iron-Copper.

In pig iron the consensus of opinion agrees that there is no market. Reports of heavy sales at low figures are unconfirmed, and the lull continues. The decline in pig iron has not stimulated the market, nor do consumers seem to be worried about getting all the iron they need. There is not enough business reported to warrant any change in prices. Copper was reported higher, especially in the London market. The advance is presumably based on the statistical reduction of stocks in the Old Country. Trade sentiment is always affected by

these reports, even although there may be nothing to them. It is a factor in the market, however, and must be reckoned with. On the whole a favorable effect is to be noted on the copper market. Tin is featureless, although some reports were higher. Spot and nearby deliveries were lower, and the demand was not as good as last week. The London market reported an advance on futures, but nothing new. Lead and spelter markets are reported weak and neglected. Antimony and aluminum are dull and uninteresting. Old metals remain quiet and unchanged, a steady business being, however, reported. Hardware on shelf and in heavy lines is moving rapidly, and good prices are being maintained everywhere. Lake and river craft are laden daily with heavy shipments of builders' hardware. Bar iron is strong and active, and double refined bars are selling at a good advance.

* * *

Toronto, Ont., May 7.—The machinery market is like the waves of the ocean; one minute it is up, the next it is down. It is down this week, and quietness pervades the atmosphere. There are two new specifications issued by the C.P.R. for machine tools in their new shops at

McAdam Junction, N.B., and for those to be built at North Bay. The railways are far behind with their equipment, and that accounts for the large buying of late. Apart from these, however, little business is recorded. The Stratford Brass Co., Stratford, Ont., recently organized in connection with the Stratford Mill Building Co., have bought lathes, shapers, drills, shears, saws and grinder, from the Canadian Fairbanks-Morse Co., Ltd., at a cost of \$3,000. The Ottawa Car Co., of Ottawa, are completing a new machine shop, and have not yet purchased the equipment required. Business in the contractor's line is not very brisk, the chief business being done among railway contractors, and bridge builders.

Pig Iron, Etc.

Things are as quiet in the steel market as in the machinery. The business being done in pig iron is negligible. No contracts are being made, and lots purchased are small. Manufacturers seem to be busy in their respective lines, but they are not purchasing steel. It is believed they are holding off until prices lower, but steel men think they will be fooled. Warehouse business, however, is brisk. Bars are firm, and there are quite a number of inquiries at mill for reinforcing steel from structural men.

Metals.

Prices of metals are the same this week as last, and business is reported good.

Classified Advertisements

Those who wish to sell or buy a business, obtain competent help, connect with satisfactory positions, or secure aid in starting new enterprises should not fail to use the "Want Ad. Page of "CANADIAN MACHINERY."

If you want to sell or buy a second-hand lathe, planer or any other shop equipment, let "CANADIAN MACHINERY" pick out a seller or buyer for you. How about that second-hand engine or boiler which you would like to dispose of?

"CANADIAN MACHINERY" is the central market place of the machinery trades throughout Canada.

There is always some one looking for just such proposition as you have to offer.

Rates (payable in advance):—2c per word first insertion, 1c per word subsequent insertion, 5c additional each insertion when Box Number is required. Each figure counts as one word.

SITUATION WANTED.

SUPERINTENDENT OR ASSISTANT superintendent position desired by young man with 13 years machine shop, drawing room and executive experience, practical machinist, draftsman and tool designer; experienced on premium, bonus and day work systems. Address Box 431, Canadian Machinery, Toronto. (16)

POSITION WANTED

POSITION WANTED—SUPERINTENDENT or general foreman by master mechanic with high technical training and broad, practical experience in economical production methods; foundry, machine shop, press work, tool and die work; have originality and initiative ability; experience in handling men is varied and extensive. Box 130, Canadian Machinery. (16)

MACHINERY FOR SALE

FOR SALE—A JOHN BARNES NO. 4½ FOOT power lathe; screw cutting; steady rest; full set of gears; two face plates; takes 25 in. between centres; in new condition. Suitable for amateurs or a small jobbing shop. Apply Box 125, Canadian Machinery, Toronto.

**FOR SALE
CORLISS ENGINE**

MADE BY JOHN INGLIS CO.

200 horsepower; 18 in. x 36 in. cylinder; 30 in. x 17 ft. flywheel.

This Engine is in Excellent Condition.

APPLY

**THE STEEL COMPANY OF CANADA
ROLLING MILLS Limited**

Indian Rd. and Lake Shore Rd.,
TORONTO, ONT. (17)

New Incorporations

Colwell Lead Co., incorporated at Toronto, to manufacture and deal in tinned lead pipe. Capital, \$40,000.

Stone & Webster Construction Co., incorporated at Toronto, to do engineering and construction work of every description. Capital, \$40,000.

The Pink McVeity, Blackburn Co., Ltd., incorporated at Toronto, to manufacture motor cars, etc. Incorporators: John F. Orde, Montagu Powell, Norman W. Lyle, Mary Pigott, Sarah L. Farrell, all of Ottawa.

Reid, Macgregor Co., Ltd., incorporated at Ottawa as general contractors and engineers. Capital, \$125,000. Incorporators—W. R. L. Shanks, F. G. Bush, G. R. Drennan, H. W. Jackson and M. J. O'Brien, all of Montreal, Que.

Sangamo Electric Co., of Canada, Ltd., incorporated at Ottawa, to do business in Montreal. Capital, \$50,000. Incorporators—L. MacFarlane, Charles A. Pope, G. Barclay, Wm. B. Scott, and J. G. Cartwright, all of Montreal, Que.

Victor Saw Works, Ltd., incorporated at Toronto, to manufacture and deal in all kinds of saws and small tools. Capital, \$40,000. Incorporators: J. W. Nesbitt, J. G. Gould, C. V. Langs, L. H. Grey, and N. Moore, all of Hamilton, Ont.

The Metropolitan Engineering Co., of Canada, Ltd., incorporated at Toronto, to manufacture electrical apparatus; incorporators:—Joseph S. Lundy, Charles G. O'Connor, Jean McGillicuddy, Alice Dwyer, all of Toronto; Mabel Anderson, of Streetsville.

The Teck-Hughes Gold Mines, Ltd., incorporated at Toronto, to develop and work mines, with \$2,000,000 capital. Incorporators:—William L. Amiraux, Ida H. Harrison, John A. Campbell, Elsie

PATENTS

PIGEON, PIGEON & DAVIS

71A, ST. JAMES STREET, MONTREAL

Phone, Main 3025

TRADE MARKS, COPYRIGHTS & DESIGNS
PATENTS
LLOYD BLACKMORE & COMPANY
LUMSDEN BUILDING, TORONTO.
ALSO, HOPE BLDG. OTTAWA, & WASHINGTON, D.C.
We have an interesting and valuable booklet "Patent Protection" which will be sent free upon request.

99%
OF ALL METAL BREAKS CURED
BY OUR OXY ACETYLENE
WELDING
EXPERTS
RUSH WORK OUR SPECIALTY
THE FRANCO-CANADIAN WELDING CO., 331 Yonge St. TORONTO

HARKER & KEMBLEY
Machinists
And Brass
Finishers
Brass and Aluminum Castings
Fire Department Supplies
All kinds of Special and Experimental Work
81 PETER ST.
TORONTO
PHONE ADELAIDE 1031

Morton Manufacturing Co.
Draw Cut Shapers, Special Draw Cut R. R. Shapers, Special Locomotive Cylinder Planers, Portable Planers, Stationary & Portable Key Way Cutters, Finished Machine Keys.
Office & Works, Muskegon Heights, U.S.A.

PATTERNS
WOOD AND METAL
Allow us to estimate. Satisfactory work guaranteed.
TAYLOR PATTERN WORKS WALKERVILLE, ONT.

Chemical Control for { FOUNDRY CORE ROOM AND POWER PLANT
"Chemists to the Manufacturer"

THE TORONTO TESTING LABORATORY, LIMITED

160 Bay Street, Toronto

Special Rates on Contract Work.

UNEQUALLED SERVICE

Tests on Metals, Fuels, Oils, Water, Etc.

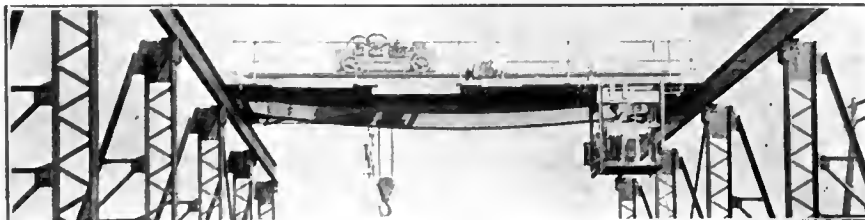

CRANES

All kinds and sizes for all purposes. Detailed specifications and prices upon request.

John T. Hepburn, Crane Builder, Iron Founader and Machinist
18-40 Van Horne St., Toronto, Can.

New Plant of the Pease Foundry Co. Ltd., at Brampton, Ont.

By Chas. W. Byers

There is something romantic in the rise of the Pease Foundry Co., Ltd., from a simple selling agency to the size which this concern has assumed within the space of three decades. They have recently commenced operations at their new Brampton plant and, judging from the rate at which they are going ahead, the names of Pease and Brampton will one day be synonymous.

THE Pease Foundry Co., Ltd., of Toronto, started operations in 1885 as selling agents for J. F. Pease Furnace Co., of Syracuse, N.Y. Shortly after this, the company was organized on a manufacturing basis, still with American shareholders, operating a foundry out at New Toronto, and assembling the eastings in the city on Shaw Street. The product was originally made from the American patents of furnaces made by the Syracuse company. As time went on, individual lines of warm air furnaces, expansion furnaces, large steam heaters and ventilators were evolved. This, at the present time, forms the basis of the casting business, although certain other lines of hot water boilers and radiators are handled on a jobbing basis.

Some 15 years ago the American shareholders sold out their interests to Canadians, and since then it has been run purely as a Canadian enterprise. The foundry was retained at North Toronto and the machine shops, assembling rooms, etc., in Toronto. About a year ago the firm sold their two plants in North Toronto and Toronto, and consolidated their works in a large plant at Brampton, Ont., only warerooms being kept in Toronto at 118 King Street East. An immense building has been constructed in the above town. Brampton is an ideal town from a manufactur-

er's point of view; recently there has been considerable talk of another large Toronto foundry being established there. The town is situated on both main railway lines, and is quite close to Tor-

ers; the Williams Shoe Co., and there is also within its limits the largest greenhouse in the world.

The president of the Pease Foundry Co., Ltd. is D. J. McKinnon; vice-president, J. W. Beynon, K.C.; treasurer, J. L. Ross; sales manager, R. B. McKinnon; manager of the Brampton plant, J. G. McKinnon; superintendent of foundry, J. R. Phillips, and mechanical engineer, E. C. Bettendorf. Others holding important positions at the Brampton plant are D. Lindsay, machine shop foreman; Chester Beswick, foundry clerk; G. Cooper, foundry foreman; and W. S. Hallett, electrician.

Lay-out of the Plant.

The work of designing the new plant at Brampton was given to Messrs. Ellis & Connery, architects, Manning Chambers, Queen Street West, Toronto. The foundations were started in September, last year, and in March, 1913, the Pease Foundry Co. started operations, although the building, even now, is not quite complete. This early move was necessitated by the sale of the old plant at New Toronto, which took place early in the year. The new plant is a one-storey factory building with concrete foundations, pressed brick walls, metal sashes throughout, of steel construction, and with a plank, felt and gravel roofing.

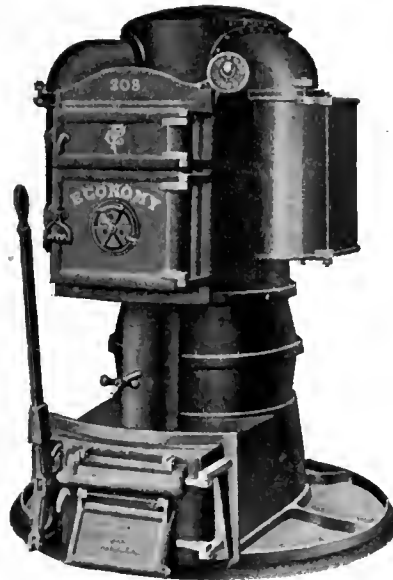
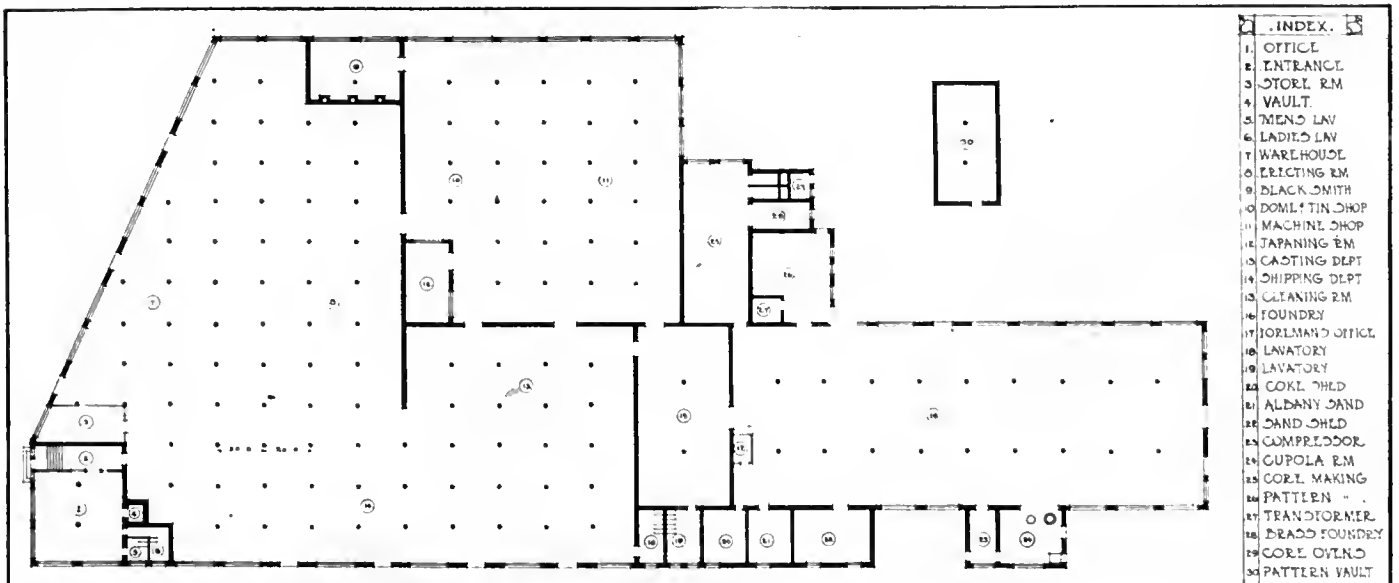

FIG. 2. PEASE ECONOMY HEATER.

onto. It is a local option town, and labor is much easier to get than was expected. Among other plants in this thriving municipality are the Copeland-Chatterson Co., loose leaf manufactur-



PLANT LAYOUT, ELLIS & CONNERY, ARCHITECTS, TORONTO.

A glance at Fig. 1 will readily give an idea of the lay-out of the foundry. Roughly speaking, it is divided into three large buildings, the moulding shop on the right, the warehouse on the left and the machine shop in between. Other important departments of smaller size are the cleaner room (No. 15) the pattern shop (No. 26) the core room (No. 25) and the cupola room (No. 24). These are all

10 and 11, we find adjacent to this, the japanning room and the blacksmith's shop (Nos. 12 and 9). Number 30 is the pattern vault which is isolated from the rest of the building, reference to which is made later on.

In the Moulding Shop.

The moulding shop measures 200 by 80 feet, and is composed of three bays.

est features in building construction. At one end, facing northwards, is the superintendent's office. This is a room of light construction, with plenty of window glass in it so as to afford the foreman, while sitting at his desk, every opportunity of seeing all that is going on in this section of the building. Most of the moulding in this plant is done on the floor.

On the right and left of the moulding shop, several smaller buildings are connected. Proceeding from the superintendent's office on the right, we first come to the foundry supply room, in which are kept riddles, bellows, etc. The next room on the right is a smaller one, and is used for storing fine sand specially prepared for register work. This is imported by the firm from Albany, N.Y. There is another room for machinery sand.

The Cupola Room.

We next come to the compressor room, containing a Canadian Rand air compressor, measuring 14x9x12, run by a 75 h.p. Westinghouse motor, hydro-electric power being used. This supplies power for the hoists over the floor. A door from this room leads into another of similar area, but of about twice the height. Here is installed a cupola, with a 72-inch shell, bricked up to 47 inches. This is a Newten Cupola, made by the Northern Engineering Works, Detroit, Mich. At present there is just one in this room, but accommodation has been made for another, which lies outside in the yard, and will be placed in position as soon as required. When both are installed, they will be used alternately.



FIG. 3. PART OF MACHINE SHOP USED FOR TINSMITHING.

adjacent to the moulding shop. Then, looking at the warehouse, we find that it is also made use of as an erecting room, shipping room, and a place for storing castings. Adjacent to the warehouse is the manager's office, which is quite near to the main entrance. Then, looking at the machine shop indicated by numbers

It is served by two jib cranes and a trolley system. The latter runs around the entire middle bay. This, together with the two jib cranes and their hoists were supplied by the W. D. Beath Co., of Toronto. Each crane has a three-ton capacity. It is a large, airy, well-lighted building, embodying all the lat-



FIG. 4. GENERAL VIEW OF MOULDING SHOP.

The other eupola has a 60-inch shell, and did good work in the old Pease Foundry at New Toronto. It is a Whiting eupola, made by the Whiting Foundry Equipment Co., of Chicago, Ill.

Pig iron and eoke are brought into the eupola room by a side entrance from the

by a 30 h.p. Westinghouse motor, and is geared to it by a rawhide pinion. There is an 18-inch discharge. The eupola is in a position suitable for expeditious work, being right in the heart of the floor where most of the large eastings are made. In the far right hand corner are

most up-to-date in the Province of Ontario. Three ovens are being built: a very large one which will be equipped with a tramway; a smaller one; and a smaller one still, running parallel. These are equipped so that the heat can be changed readily from one oven to an-

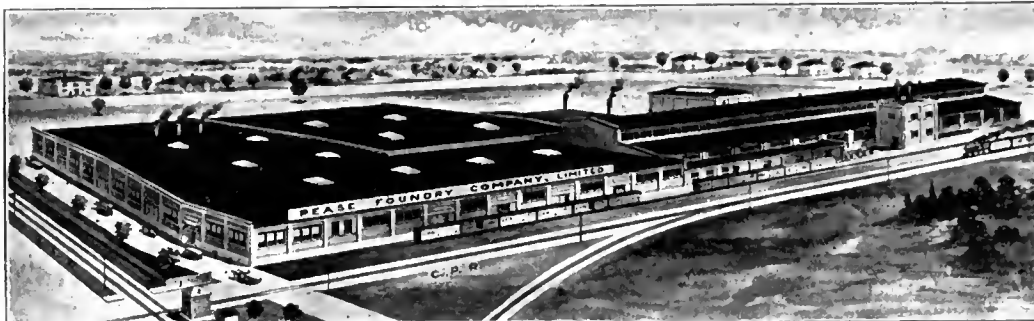

FIG. 5. BIRD'S EYE VIEW OF THE PLANT.

yard. It is weighed on a Fairbanks' scale, specially adapted to this work. From the scale it is wheeled on to a hoist, and carried up to the charging floor. The

situated bench molders, of which there are four. There are three others distributed around the building. These are occupied mainly with register work, us-

other. In the largest core room, until put into operation, the firm intend to install a small furnace for brass and aluminum work. Leading from the core



FIG. 6. CLEANING ROOM, SHOWING TUMBLERS.

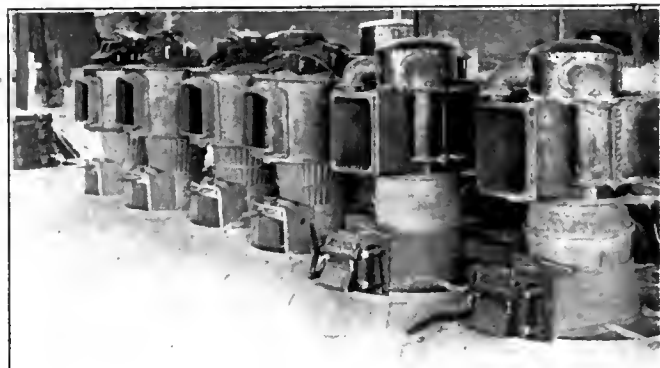

FIG. 7. FURNACES IN COURSE OF ERECTION.

latter has an area equal to the area of the eupola room. The hoist was made by the Otis-Fensom Co., of Hamilton, Ont. It is operated by a Westinghouse

ing brass patterns, and very fine Albany sand.

Now, proceeding from the manager's office on the left, we first come to the

room, there is a smaller room in which are installed transformers used for stepping down the Hydro-Electric power to suit the firm's requirements.



BOARDING HOUSE AND COTTAGES FOR THE WORKMEN.

motor, attached under the floor of the charging room.

On the charging floor there is a Root rotary pressure blower, Size 5, made by the B. H. & F. M. Root Co. This is run

core room. At present this is under construction, a temporary core room having been erected on the floor of the moulding shop. The core room, when completed, will be one of the

Proceeding on the left, we come to what will be used by the firm as a pattern-makers' room. Here they will install or band and cross cut saws, run by a 5 h.p. Westinghouse motor. When this

is in full operation, there will be three or four men employed on metal work, including aluminum match plate, and three or more on wood.

The Pattern Vault.

Situated in the yard, isolated from all other buildings, is a fireproof pattern vault, used for storing the valuable patterns used by the firm in their furnace work. This is a square building without any windows, built of brick, steel and concrete, and lighted by electricity. It has steel shelves to carry the patterns, and the floor is of concrete.

The yards to the north of the moulding shop are served by switches, both from the Grand Trunk and Canadian Pacific Railways. Here are stored the flasks used in the foundry, and large

cope since it moved its plant from New Toronto to Brampton. One of the chief drawbacks in the eyes of the men was that Brampton was a "dry" town which, while it no doubt tends to keep a man straight when once settled down, tends to keep him away after being used to the freedom of the neighboring city. So far, the firm have nowhere near the number of men they would like to have in their moulding shop. They have vacancies for a number of first-class moulders, for pattern makers and a few laborers.

Cleaner Room.

The cleaner room is of the same type and construction as the moulding shop, being really a continuation of that building. As is necessary in a building

tumblers, and as they revolve, they carry away the sand and dust into an adjacent room, where it is received in a large chamber, and wheeled away as it accumulates.

The cleaner room is immediately to the south of the moulding shop, and laborers are continually wheeling castings from the latter to the former. These castings include such parts as pipes, large furnace sections, registers, dampers, grids, etc. They are packed into the tumblers according to their size, and cleaned: afterwards they are chipped, ground and drilled. The foundry clerk superintends the counting and weighing of these sections, whereupon they are moved into the machine shop and assembling room.

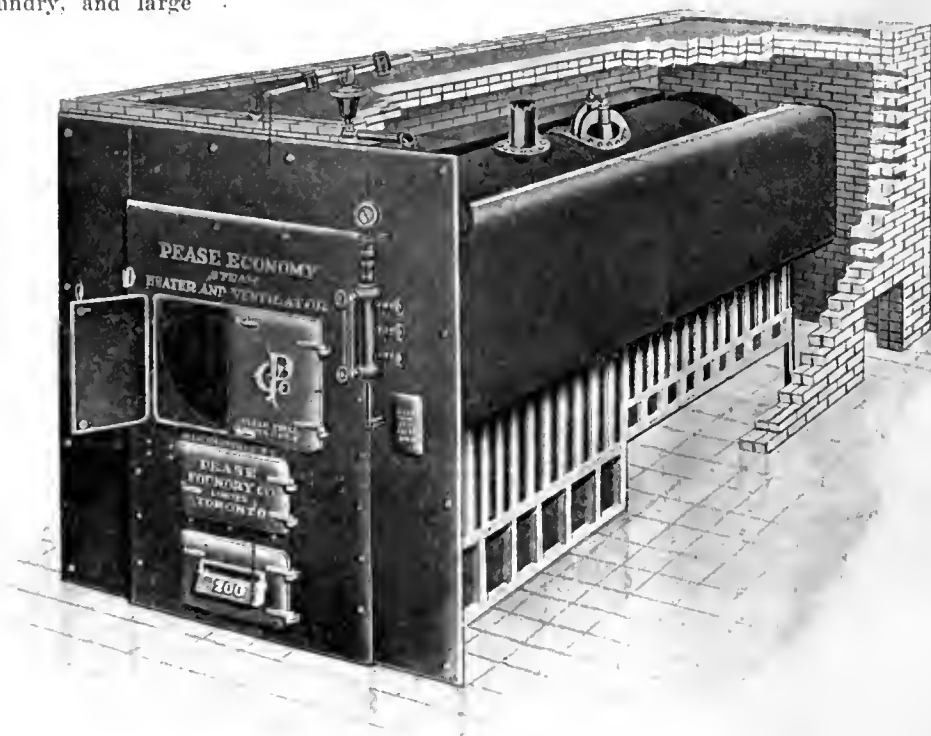

FIG. 9. "PEASE" ECONOMY STEAM HEATER AND VENTILATOR.

quantities of coke and iron and other supplies. In the distance can be seen several houses which are being built by the Pease Foundry Co., for their workmen. Particularly interesting among these, is a large boarding house built to accommodate Polanders, who form a considerable portion of the men employed in the moulding shop. Some of these have been brought up by the firm from their old plant in Toronto, having spent years training them to be first-class moulders. The boarding house referred to consists of 6 or 7 houses in one block, and is sufficient to house quite a number of these men. There are also several semi-detached residences built for the foremen employed in the works.

The labor problem has been one of the chief with which this firm has had to

where the air quickly becomes laden with deadly dust, sufficient ventilation is provided, a system of sheet iron pipes connected with the tumblers carrying away the bulk of the dust before it reaches the outside air. This dust is later used as parting sand. Thus the health of the men in this room is safeguarded, which is required in all foundries according to the law of the Province.

There are six tumblers in the cleaner room of various sizes, according to the size of the castings to be cleaned. These are driven from a single line of shafting, supplied by power from a 30 h.p. Westinghouse motor. In this room there are also several grinders and drills to which the castings are carried after leaving the tumblers. As stated before, a system of pipes connects with the

Making Hinge Holes.

One of the features of the doors of the Pease furnaces is that the holes do not require drilling after leaving the moulding shop. Because of a device invented and patented by Mr. James R. Phillips, foundry superintendent, these cast doors leave the moulding shop with their holes in perfect alignment. Formerly, the firm employed hinge tubes which consist of a core inside a tin structure. This was so designed as to allow the tin to unite with the iron when casting took place. In the system invented by Mr. Phillips, instead of a hinge tube, he uses chilled bars which are put in place by an ingenious device, and left there when the pattern is withdrawn. Thus the chilled bar takes the place of the sand core, and is easily removed

when the casting is made, leaving behind an excellent hole. It is claimed by the firm that since this method was adopted they have been able to put three sets of doors into position in an hour, whereas when using the old method, it took an hour to do one. The firm make about 100,000 holes every year, using this device. This is only one of several inventions brought out by the superintendent during his long connection with this firm, which enable them to turn out such splendid work.

To the east of this room is one of those annexes which are to be found on both sides of the moulding shop. This particular one is to be used by the firm as a wash house and lavatory.

The Machine Shop.

When the castings leave the cleaner room, some of them are ready for immediate assembling, while others require to be machined. The machine shop is of enormous size with plenty of room for extension, which is taking place every day. In the one large room, castings are machined, and a large part of the floor space is taken up by tinsmithing work. The machine tools, such as grinders, saws, pipe-threading machines, lathes, shears, etc., are driven from one line of shafting connected with a 10 h.p. Westinghouse motor. On the other side of the room there is another line of shafting driven by a motor of the same capacity, which supplies power to the rollers, punches and shears used by the tinsmiths. There are several smaller rooms, offshoots from the machine shop, such as a blacksmith's shop which has three forges of the firm's own design; the electrician's room, which is only temporary, and the dipping room, where the registers are japanned. The blacksmith's shop will be used for general work, such as for making tools required, dome heads, etc.

Machine Tool Equipment.

Among the machine tool equipment are several rollers, both large and small, made by the Badger State Machine Co., Janesville, Wis., power punches, power shears, lathes, the product of the firm of John Bertram & Sons, Dundas, Ont., a shaper by the Cincinnati Shaper Co., Cincinnati, Ohio, several grinders made by the H. W. Petrie Co., of Toronto; several drills by the same firm, a power back-saw manufactured by The Robertson Manufacturing Co., Buffalo, N.Y., and a threading machine by D. Saunders' Sons, Yonkers, N.Y. This is only a small portion of the machine tool equipment which will be required by this large and enterprising firm.

The machine shop is the most central of all the rooms in the foundry and, as

will be seen from Fig. 1, has connection from three points with the warehouse, erecting and shipping departments. The latter is the largest room in the building. A trolley system connects the machine shop with the warehouse, so that furnaces ready for assembling can be moved expeditiously.

In the warehouse, all kinds of furnaces manufactured by the Pease Foundry are put together, including a steam heater and ventilator, a patent which, as the name applies, performs two operations, that of heating the building and ventilating it. The principle is that cold air enters the building from the outside and proceeds to the boiler, where it is heated, and after performing its function, is let out through a foul air flume. The boilers for this furnace are at present being made in Toronto by another firm.

Electrical Equipment.

An expert electrician is employed to look after the electrical equipment which plays such a large part in this building. Before long they will be using electric motors aggregating 600 h.p. In the transformer room there are three 50 k.w. transformers, stepping the power down from 2200 to 550 volts. There are also two 10 k.w. lighting transformers with a range of 2200 to 110 volts. These were made by the Crocker-Wheeler Co., of St. Catharines, Ont. The switchboard, which was made by the Westinghouse Co., of Hamilton, consists of three panels, and is supplied with two automatic oil switches. The power is distributed at 550 volts from four circuits of the panel. The A. B. Olite reflector is used throughout the building, the lamps being Tungstens, those in the moulding shop having a capacity of 250 watts.

The latter building is lighted at night along three bays. It is also well ventilated with vanes, and with windows which can be opened wide to keep the place cool in summer time. Owing to the large number of foundries which have fallen victims to fire of late, special precaution has been taken in this direction. Stand pipes are to be found in every room, coupled to suitable lengths of hose.

The machine shop has three connections with the warehouse. The latter building has just been completed, whereas the moulding shop has been in full swing for several months. The warehouse is of irregular shape, and measures roughly 174 by 225 feet. The floor consists of four coats, tar, felt, gravel, and on the top, maple. This type of floor is to be found in all the rooms with the exception of the moulding shop. In one corner of this warehouse is the office of Mr. J. G. McKinnon, the manager of

the plant, which measures 40 x 40 feet.

Foundry Superintendent.

Mr. J. R. Phillips, foundry superintendent, has had a lifelong experience in foundry work. He was apprenticed for four years with the John Abell Engine and Machine Co.; he was also with the Canadian Runley Co., the John Doty Marine Engine Works, the Gurney Foundry, Massey-Harris Co., and the Toronto Radiator Co. He accepted the position as superintendent of the Pease foundry at New Toronto in 1890. Some time ago the firm presented Mr. Phillips with an illuminated address, the occasion being the 22nd anniversary of the works at New Toronto. From New Toronto he went to Brampton to superintend the operations of the new foundry above described, and took off the first cast on March 26th of this year.

Mr. Phillips is a familiar figure at foundrymen's conventions, and is well known in this line on both sides of the border.



VANADIUM IN LOCOMOTIVE SPRINGS.

THE Illinois Central Railroad has completed some comparative tests on carbon and vanadium steel driving and engine truck springs. Sets of each kind of springs were applied to two 10-wheel locomotives of the same class, operated under the same conditions. The springs were of the same design. The following table will show the results:

	Carbon miles.	Chrome vanadium, miles.	% in favor of latter.
Driving springs . . .	42,145	146,587	248
Engine truck springs	34,635	79,567	129

The records show that because of their longer service the chrome-vanadium springs cost from 31 per cent. less in the case of engine truck springs to 54 per cent. less for driving springs. The complete records cover a period of over 2½ years of service. The increased requirements resulting from heavier equipment are causing increased spring failures, one road reporting as high as 1,000 per month.



W. S. Beath & Son, Ltd., engineers and manufacturers, Toronto, have just issued catalogue C, dealing with mechanical coolers and overhead runways for canners. It gives an illustrated description of the installation supplied to the British Canadian Canners, at Bowmanville, Ont. and four other plants.

The Proposed Workmen's Compensation Act for Ontario

By Chas. W. Byers

An article on this subject could not be more apropos than at the present time, when this remarkable measure is about to be discussed and introduced by the Ontario Legislature. For three years Sir William Meredith, the chief justice of that province, has been studying the matter, and his recommendations are now before the House. As it stands, manufacturers are opposed to it; the workmen are delighted with it. The writer has outlined the Bill as clearly as possible in its present incomplete state.

WHEN any advanced legislature is passed there is always somebody ready to throw up their hands in horror. When Mr Lloyd-George introduced his national insurance scheme two years ago he was assailed both by the employers and employees alike as a tyrant, not to mention the parting tussle he had with the doctors. The legislation was good, and it passed. Someday, British workmen will wonder how the wheels ever kept running in the olden days. When Mr. Rodolphe Lemieux introduced his measure for the prevention of strikes in the Canadian House, it was the employee who objected, and he has not been reconciled yet, though the country is much freer from industrial strife than it was prior to the enactment. The Act is such a boon it is being copied by Great Britain.

Thus, when Sir William Meredith was appointed by the Ontario Government in 1910 to study the operation of workmen's compensation legislation in other countries and to receive the opinions of employers and employees on the subject, there were those who threw up their hands in horror—particularly employers—and wave them wildly now that the Workmen's Compensation Act of Ontario is nearing completion. As for the workmen themselves, they are just delighted with the Bill, and their only trouble is that it is a long time in receiving sanction.

No Measure This Year.

On April 2, Sir James Whitney, the premier, presented to the House an interim report from Sir Wm. Meredith, and a draft bill, which has not met with much objection. In a letter, the Commissioner stated that he had not yet arrived at a point where he was able to make a final recommendation to the Government, but he hoped to do so very soon. Thus it seems that the measure will not pass this year.

The Bill is based both on the individual and collective liability principles, and it is the former that is calling forth much hot criticism from employers of labor. Under the individual system, the employer pays out of his own pocket damages suffered by his employee; under the collective system, the dam-

ages are paid out of a fund into which all employers pay, according to the riskiness of the work their men perform, or the safety of their machinery.

Provision is made for the appointment of a board of three, which shall administer the Act. These three commissioners will be vested with wide powers, and none may be interested directly or indirectly, in any industry, employment or business to which the Act applies. They will be independent of the courts, and their decision will be final, and not open to review in any court. Their proceedings may not be restrained in any way. The commissioners will fix the compensation to be paid by an employer who is individually liable.

No Contributory Negligence.

There is one outstanding feature in this Bill which, if it has not been adopted in other countries, would make even the workman himself gasp. The Bill teems with nice points and interesting innovations, but the fact that negligence is eliminated from consideration, eclipses them all. The only exception is in the case of a workman whose injury is due to deliberate negligence or disobedience, but, if this workman dies or is permanently disabled, compensation is paid to his dependents.

The industries of the province will be placed in several groups. Little indication is given yet as to how this grouping will be arranged; hazard will be taken into consideration. The State of Washington Workmen's Compensation scheme, it is said, will be copied in this respect. There, "extra hazardous" industries are divided into forty-eight classes, in which premiums are fixed on the wage roll according to the risks taken. Thus each class bears its own burden of compensation. In the case of fatal accidents, compensation is paid out of a reserve fund; in case of temporary injuries, compensation is paid periodically. Lump sum payments are permitted for the loss of an arm or leg, or other partial disablement.

The Railways Considered.

To the draft of the Bill as submitted to the House on April 3, two schedules

are attached; one gives the group into which industries are to be divided, and the other deals with exceptions. These include steam, street and incline railways; machine shops, steam and power plants and other works used for railway purposes; construction operations, telephone and telegraph lines, and the construction and operation of steam vessels. Farmers, retail merchants, etc., may also be eliminated, but the disposition of these is left to the Legislature. In the case of the exceptions just noted, the employers will be individually liable for compensation, on a basis to be determined by the board.

All other industries then, will be subjected to an assessment, based upon the annual-pay roll. Clauses are inserted in the Bill, penalizing the careless or negligent employer. In cases where an undue number of accidents have occurred due to proper precautions not being taken, or where machinery is defective or insufficient, the board may increase the assessment, or leave the employer individually liable for compensation. It may conduct an examination of any plant, and if an employer does not supply a statement of his pay-roll, their assessment will be fixed on an estimated pay-roll. The books of the concern must be available for inspection.

Payment of Compensation.

Now as to the awards: in the case of an accident which terminates fatally, a sum not exceeding \$75 is allowed for burial expenses. Where the dependents are a widow or an invalid husband, a monthly payment of \$20 is provided; where there are one or more children, an additional \$5 per month is allowed for each child under 16, the total not exceeding \$40 a month. A father or mother may collect \$20 a month for the death of a child under 21, until the time the son or daughter would have become of age. In no case can the compensation exceed \$40 a month. Where a workman is totally disabled, he will be able to collect 55 per cent. of his average weekly wage during the last year of employment.

The last of these is intended to benefit the man whose wages exceed the level where the general scale would be too low. In case of death, the pay-

ments will probably be of the same percentage.

The board will have power to compel employers to put up a guarantee for the payment of a reasonable amount of death compensation, or to insure against bankruptcy with a liability insurance concern, in cases where the employer is individually liable. The schedule of benefits beyond this has not been completed.

Interesting Points.

There are one or two points incidental to benefits which are interesting. For instance, if a dependent widow marries, her claim ceases, but she is entitled to a lump sum equal to the monthly payments for two years. When the dependents of the deceased are non-residents of Ontario, the dependents will only be entitled to compensation if the country in which they live would do the same were the conditions reversed, and the dependents living in Ontario.

When a man who is killed has no dependents, the compensation will amount only to medical and funeral expenses. Thus will the homeless man without relatives become a popular employe.

The principal contractor is responsible for accidents occurring under sub-contractors, but may carry the case to the common courts.

The expectancy of life will be considered in paying compensation to dependents of old men who have been killed.

The compensation paid to an invalid wife will exceed that paid to one who is not ill, and women with families will get more than those without a family.

The workman who accepts compensation under this Act, relinquishes all right to private action to recover further compensation.

Not only are accidents covered by the Act; where a man dies from one of several industrial diseases, his dependents will secure compensation. Five are diseases are mentioned in the Act. These are: Lead poisoning, mercury poisoning, phosphorous poisoning, arsenic poisoning, and anthrax. Where a workman suffers from one of these, compensation will be paid unless it is proved that he suffered from it before employment.

The lawyers will feel the introduction of this legislation bitterly. This Act will do away with an immense amount of litigation. Witnesses may be necessary and lawyers too, but the expense and the time lost due to trials and appeals will be reduced enormously, and the cost of keeping up the courts will be reduced.

Opponents of the Bill.

Let us look at the arguments made against the Act. These came mainly

from the Canadian Manufacturers' Association, representing 85 per cent. of the pay-roll of the province. They do not advocate, and will make every effort to oppose a collective system, if it is not conducted on the current cost plan. If there is to be a capitalized plan, then the manufacturers want a provision for the formation of private mutual insurance associations which will, by selection of risks and accident prevention, reduce the rates.

The plan recommended by Sir Wm. Meredith is one in which a capital sum or reserve is set aside to provide for death or total disability claims. The manufacturers advocate the current cost system, with provision for a surcharge. They claim that the capitalized cost system would place an undue burden upon industries at the inception of the system.

Manufacturers vs. Railways.

The Canadian Manufacturers' Association claim that the issue is not with the workingmen, but with the employers' liability interests, supported by the C.

P. R. and other railway companies, and that the Bill was drafted to meet their views, and render it unjust and oppressive to other classes of employers. The manufacturers also urge that the workman contribute to the fund in some form.

Another great objection of the manufacturers is in cases of disability where it is proposed to give the workman the choice of taking the flat rate pension or half his weekly earnings during the 12 months. They claim that beyond the maximum amount fixed in the schedule of benefits there is a super-maximum of an indefinite amount, which might conceivably reach \$20,000, or \$25,000, or even \$50,000. No period of years is named.

The workingmen have objected to the grouping of the railways, etc., under the individual liability scheme. They are also opposed to a system of contribution by the men themselves.

However, all these matters will be settled in the Legislature when the bill is brought forward.

Methods Adopted for Avoiding Fire in a Factory

Manufacturers who have a boiler house in connection with their plant, must be shocked every time they read in the daily newspaper that another firm has been burned out through a fire originating near the boilers. By reading this article, and acting on it, the owner of property may live in greater security.

TWENTY years ago, when the automatic sprinkler was less known and manufacturers were skeptical about its efficiency, fire protective engineers were often called on to make a practical test to prove that the sprinkler would extinguish a fire. For this purpose a shack was built and installed with a make-shift sprinkler system; then, a fire of shavings and oil and pitch was made in the room. Inside of a minute, it was out. Sometimes a manufacturer was daring enough to permit a test to be made on his plant, which generally resulted in him having all his property fitted out with sprinklers.

That is twenty years ago. To-day, the fact that insurance companies are willing to reduce their rates to a minimum where sprinklers are installed, is sufficient test for the average man. The sprinkler has proved itself efficient. And yet, almost every day, one hears of a plant being demolished by a fire which originated in the boiler house.

The writer had a conversation recently with the chief expert of the General Fire Equipment Co., Ltd., of 72 Queen St. E., Toronto—a man who spent his whole life in a study of the automatic sprinkler system. Referring

to the frequency of fires occurring in boiler rooms, he said it was the most natural thing in the world, as it was there that fire was used, and probably the only place in the building where smoking was permitted. To permit the sprinkler system to operate in buildings where the temperature is higher than normal, the fusible heads are made for four temperatures:—165 deg., which is normal; 212 deg., which is used around low pressure boilers; 312 deg., and the highest 360 deg. The three last are painted different colors, so that an inspector can distinguish them at a glance. Engineers always place a 212 deg. head in sky lights, where there is a danger of the sun focussing on it.

Dangerous Basements.

A boiler house should be fitted with the system for another reason: It is a basement, and a dangerous place for a fire. In New York City, all basements are supplied with sprinklers where possible, and particularly where power is used. Smoke and fire coming from a basement are difficult things for a fireman to tackle.

To those who are not familiar with the system, and who have not considered it worth their while to go into the matter,

it might be well to give a short description of the apparatus supplied by the General Fire Equipment Ltd. It consists of an installation of automatic sprinkler heads, valves, pipes, and other appliances. The pipes carry water under pressure to all the sprinkler heads, from two acceptable supplies. The heads are attached to the pipes near the ceilings usually 8 to 10 feet apart. The head is a device consisting of a valve held in place by fusible solder, which is released by heat when a fire occurs.

The head when opened is rid of all encumbrances, and free to force a good supply on the burning area. On the head is a deflector for giving a uniform distribution. This used to be rotary, but because of the noise made by a number of these in a plant where there was much vibration, it was decided to make them stationary.

Two Sprinkler Systems.

There are two types of sprinkler equipment: the wet system, and the dry. In the later case, the pipes are filled

sprinkler heads over windows and under eaves, so that a fire in a neighboring building will not damage the plant. These give a sheet of water through which fire will not penetrate.

Large Plants Use It.

Some of the largest plants in Ontario have recently been fitted with this system, including plants of the Canada Foundry Company and the Canadian General Electric at Peterborough and Davenport. In the latter cases care had to be observed where so much electrical machinery is used, that the pipes did not become charged. The General Fire Equipment Co. are now preparing plans of an installation for the Western Canada Flour Mills, Ltd., in their mill at Goderich, Ont. In this instance an extra supply of heads become necessary in the elevator, where the hoppers would lend help to any fire breaking out. Water supplies are obtained from the city and from the lake.

In buildings where the ceilings are low, or where there is a danger of anything hitting the sprinkler head, a protecting frame is used. In coal holes

able: public water works, underwriter duplex steam fire pump, air pressure tank, elevated gravity tank, rotary fire pump. In addition to and independent of these, a steamer connection with swing check valve should be placed on the outside of building, to which the public fire department may connect and



FIG. 2. A SPRINKLER HEAD.

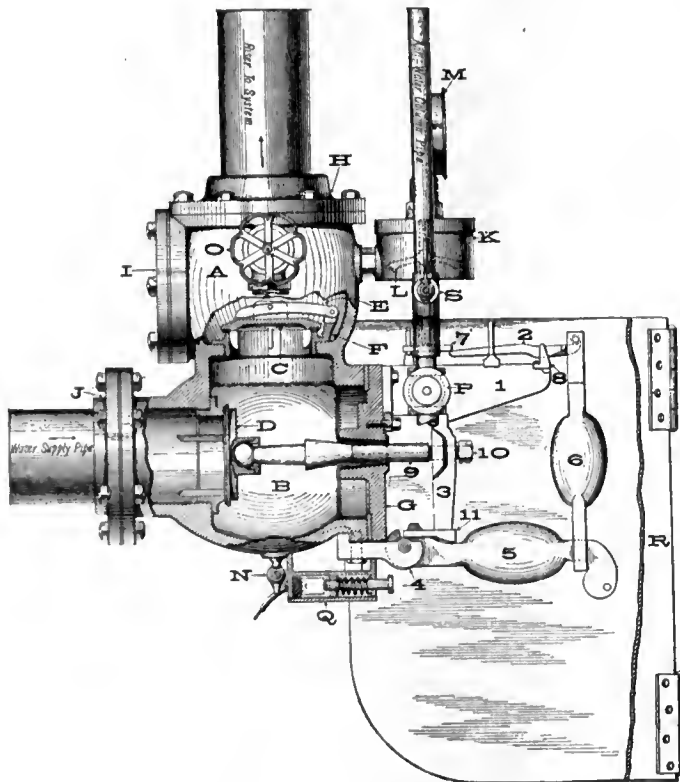

FIG. 1. A DRY PIPE VALVE.

with compressed air as far back as a controlling valve, which holds the water in check, and is released automatically in case of fire, by the air being exhausted. This system is installed in buildings not protected in winter against freezing. The valve used in this connection is shown in Fig. 1.

Further protection can be given a building by running a pipe line with

where pieces will fly up occasionally, this protection is used.

Water Supplies.

Two independent water supplies, one of which should be automatic and capable of delivering water under heavy pressure, are essential to secure the best protection and minimum rate of insurance. The following are accept-

pump direct into the sprinkler system. The gravity tank should be elevated so that the bottom of it is not less than 20 feet above the highest line of sprinklers. It may be erected upon an elevated structure on the roof of the building, or upon a steel sub-structure from the ground.

Before installing either a steam or rotary pump, due care should be exercised to furnish an ample supply of water, sufficient to run the pump at its rated capacity for at least one hour. The capacity of pumps must in all cases be determined by the underwriters having jurisdiction. None will be approved with a capacity of less than five hundred gallons per minute.

In the case of gravity tanks, the total capacity should be determined by the underwriters. These tanks should be located in an upper storey of the building, must be kept two-thirds full of water, with an air pressure never less than seventy-five pounds, that will give not less than fifteen pounds pressure on the highest line of sprinklers, when all the water has been discharged from the tank. To maintain this air pressure, various devices may be utilized, depending upon the power available.

Letters of Appreciation.

That these systems are appreciated by manufacturers in Canada is shown by the letters received by the makers. While the writer was in the office of the General Fire Equipment Co., Ltd., a letter arrived in the mail from a Toronto firm who said that, although they had had no fire, their insurance premium had been reduced so much, in a few years

they had saved in insurance sufficient to pay for the complete equipment.

General Advice.

A word or two might be said generally regarding fire protection. The heating or power plant should be in an enclosure of brick or concrete and steel, preferably located outside the building walls, with fire doors on connecting openings. Stairways should be closed in brick walls with fire doors where practicable, and if not practicable, at least enclose the stairways, and have doors top and bottom at each floor. Enclose with fire resistive materials all elevator shafts, providing fire doors at each floor.

These features as to stairs and elevator shafts are of more importance than most people realize; an open stairway acting as a flue will create a draft should a fire start in the lower floors, inducing it to sweep the whole height of the building. An elevator shaft being vertical, if not enclosed, has even a greater tendency to spread fire from floor to floor, and no openings of any kind ought to be allowed between floors

where they are not provided with automatic shut-offs.

Although it is advisable, it is not by any means necessary that these fire doors be always kept shut, except when the building is unoccupied, as they should be arranged to close automatically in case of fire.

Concealed spaces under stairs, under roofs, and in old corners such as blind attics, and closets, are always a menace, as they are generally used to store odds and ends indiscriminately, unless constantly watched. The attics should be closed up, so that there is no entrance into them, if they are not used; if they are used, particular care should be taken in the inspection of them, to avoid having inflammable material stored there, and to have suitable appliances for extinguishing fire ready at hand. Small built-in closets would be much better eliminated, and metal closets substituted for them. This is particularly the case as regards clothes closets, on account of matches in pockets.

Chemical Extinguishers.

As to extinguishing devices for this

class of building; in addition to the hose standpipes, generally installed, an adequate number of fire bucket tanks and chemical extinguishers should be provided. The best rule for an adequate number of these is to abide by the recommendations of the fire underwriters. If there are any particular hazardous places in basements or attics where it is necessary to store material that burns easily and quickly, it would be advisable to install an equipment of automatic sprinklers for these places at least.

Only one thing can be said against the automatic sprinkler system: it is unsightly. No effort on the part of fire protective engineers can make the lines of pipe and heads, beautiful. In a factory that does not matter so much as safety. In a departmental store, in a show room, or in offices, the pipes may be put in mouldings, or between the joists, or a false ornamental girder may be built for them. The pipes may be carried inside the walls. Nothing shows but the sprinkler heads, and these may be covered by a neat plate.

The Growing Plant of a Canadian Clutch and Pulley Firm

By Chas. W. Byers

Here is a young firm who have started out with two good products—a split pulley, and a combined jaw and friction clutch, of their own design. These, together with several subsidiary lines, they are pushing, and are advancing right along the line. They expect to extend their plant at Aurora, shortly.

NO one would suggest on passing through Aurora, Ont., that it figured much as a manufacturing town. Its proximity to Toronto, however, gives it an enviable situation. On reaching the

just branching out, and others are really in embryo. Among them is the plant of The Positive Clutch & Pulley Works, Ltd., whose head office is on Jarvis St., Toronto, who, until a year ago, manu-

and the wood-working department. These are two entirely separate branches. In one building the firm's split pulley is built up, turned to size and finished ready for use. In the other



WHERE THE CLUTCHES ARE MADE.

MAKING SPLIT PULLEYS.

centre of the town on Yonge Street, a five minute walk to the right will bring one to a district that is sprouting with young industries, some of which are

factured their product entirely in the Ontario metropolis.

The plant at present consists of two one-storey buildings—the machine shop,

building, the combined jaw and friction clutches are put together. These two lines are well-known patents of this firm, and their production forms the

bulk of the business. Incidentally, they manufacture the ordinary friction clutch, hangers, marine reverse gears, etc.

To Build a Foundry.

These two buildings are situated on a site of three acres, with plenty of room for expansion. The foundations have been laid parallel with the other

Aurora, made an agreement with the town whereby they were loaned a sum of \$10,000, \$6,000 of which has already been paid, and a fixed assessment.

The two buildings run north and south. The north end of the machine shop is used for the general manager's office and the shipping department. The wood-working shop includes also a pat-

are then put under a press and the arm is formed as shown in the accompanying illustrations. The purpose of this form is to give additional strength, and to reduce wind resistance to a minimum. One of the strong claims is the absence of wind resistance.

Enormous Strength.

The hubs of the pulley are made of malleable iron. The advantage of this is that it is unbreakable, and enormous compression can be got on the shafts by means of this material. The arms are forced into drilled and reamed holes in the hubs under pressure, and with the same operation, the arm on both ends of the hub is upset, so that there is no possibility of it loosening. This is a patented feature, and, the makers claim, is an improvement on the threaded or any other known method of connecting the arm to the rim. Connection is so perfect, if an error is made in pressing, it is more economical to scrap the piece than attempt to move the arms. The forming machine was specially made for the firm by the Brown Boggs Co., Ltd., Hamilton, Ont.

Putting a Pulley Together.

The other ends of the arms are flattened, and a cast iron saddle is fitted on. Then the whole centre is built into a wood rim. The arms and saddle are kept in position by hardened steel pins, which are driven through the segments and the saddle. There are two pins in each saddle.

The whole pulley is turned inside and outside on a lathe, after which the rim is treated with a water-proofing preparation.

The building is fitted with up-to-date saws and lathes suitable for this work. The lumber for the pulleys is kept sort-



LONG AND SHORT OF IT IN PULLEYS.

buildings for a foundry, which will be built as soon as the business warrants it. Nearby is the plant of The Collis Leather Co., makers of shoe leather, employing seventy-five men, and that of the Collie-Cockerill Co., manufacturers of office furniture. This is nearing completion, and will employ 50 men. The Positive Clutch & Pulley Works employ 30 or 40 men.

The woodworking shop measures 125x45 ft., and is also of reinforced concrete throughout, with curtain walls. The machine shop measures 120 x 45 ft., and is also of reinforced concrete. Both buildings are served bountifully with sunlight. When the foundry is erected, the works will be served by a spur line from the G.T.R. tracks, which run parallel with the plant. It is also served by the Toronto and York Radial line, which runs from Toronto to Aurora and further north.

Were Loaned \$10,000.

Power is supplied by the latter company, and the town has practically completed arrangements for a continuous supply. Labor is accessible owing to the nearness of Toronto. Arrangements are also being made to construct a hundred houses here, which will be necessary if all these plants are to be supplied. The Positive Clutch Co., when they came to

tern shop, in which are made the patterns for the transmission appliances; a press room, where the steel arms of the pulleys are formed, and the finishing room, where the pulleys get their last touching up.

The feature of this firm's pulley is the arms. These are made from cold drawn

seamless steel tubing, specially imported from Germany. These are in four sizes, according to the size of the pulley. The arms are cut in lengths by means of an automatic cutting-off machine. They

ed in racks at one end of the building. It is cut into lengths, and from these, segments are cut on a bandsaw with the aid of templates. The segments are then taken over to the building tables, and the

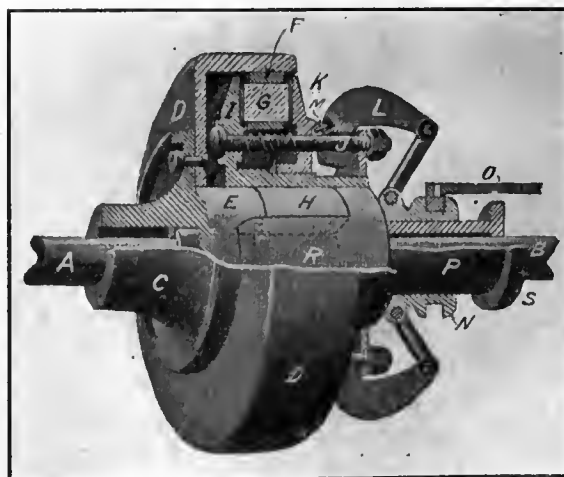

VIEW OF POSITIVE CLUTCH.

pulley built up on a centre, from which it is not moved until finished. All the segments are glued and nailed.

Thus, the arms and hub travel along the building on one side, and the segments on the other. They are then put together, and pass to the lathes, where they are turned to the size required. Bushings for these split pulleys are of cast iron, and are interchangeable for whatever size of shaft is required.

The Machine Shop.

The other specialty of this firm is put together in the machine shop. It is the combination jaw and friction clutch. The expression "put together" is used because there is much about this clutch that cannot be made at Aurora until the foundry is built. The patterns, however, are made here, the pattern shop being situated at the north end of the woodworking department.

The friction mechanism is used only for the purpose of picking up the load, the driving being done by the steel jaws. By moving the lever forward, the friction gradually picks up the load, and as soon as the speeds of the two shafts to be coupled, or pulley to be driven, are approximately the same, the friction releases, and the positive jaw engages. In releasing the clutch, the load is transferred to the friction mechanism before the jaws are released.

Friction of Fibre.

The clutch is governed by a single lever. The friction blocks are made of specially prepared fibre, which will outlive wood many times over, and has a further advantage that it will neither burn nor char.

One of the features of this clutch is the use of a sleeve filled with an interchangeable self-oiling phosphor bronze bushing. Cast steel and malleable iron are used very largely for the manufacture of this clutch, and all parts are interchangeable, being machined from jigs. In addition to a combination clutch, this firm manufactures a line of friction clutches adopted for line shafts, and for gasoline engines. In fact, they specialize on clutches for any known purpose.

Testing Clutches.

A device has been arranged in the machine shop by means of which the clutches, after being made, are put through a test, so that every clutch before being shipped may be tested, as nearly as possible under conditions like those under which it will operate in service.

The machine shop of the Positive Clutch & Pulley Co., Ltd., is, as stated above, a very up-to-date construction, and equipped with machine tools of a type that will allow them to turn out the high-class work which they do.

There are three lathes by the R. McDougall Co., of Galt, and one by the American Tool Works Co., Cincinnati, Ohio; a shaper by the Rockford Machine Tool Co., of Rockford, Ill., and various other equipment.

Fig. 1 shows a corner in the above machine shop with a few parts of clutches on the floor in course of construction.



BALL BEARING LINE SHAFTS.

EXPERIMENTS have recently been carried out in order to ascertain the exact saving in power effected in textile factories where the line shafts have been equipped with ball bearings throughout. These bearings were of a well-known make with two rows of balls in each, arranged to swivel bodily in their race. Electric power readings were taken under exactly similar conditions before and after the ordinary bearings had been replaced by ball bearings, and the result showed a saving of 30 horse-power at the engine in a weaving shed containing 900 looms. Had it been possible to eliminate the belt and rope friction, the actual percentage of saving of friction indicated in the bearings themselves would doubtless have been very considerable.

A test carried out on an edge-trimming machine shaft in a boot factory, the ordinary bearings in which had been replaced by an equal number of ball bearings, showed a saving of 80 per cent. in the power required to drive the shafting. It may be added that the speed of rotation does not affect the efficiency of ball bearings, and that the friction at starting is practically the same as when running. This is an important consideration in large factories where a fraction of a minute saved in running the machines up to speed after each stoppage will result in an appreciable increase in the total output from the machines.



SAWDUST A FIRE EXTINGUISHER.

FROM the account of some experiments made by Mr. E. A. Barrier, a Boston engineer, and embodied in a report made under the direction of the Associated Factory Mutual Fire Insurance Companies, it would appear that sawdust possesses some special merits as a fire extinguisher when dealing with small outbreaks of liquid combustibles, such as lacquer and petrol, which are usually difficult to extinguish by ordinary means. Sand is generally looked upon as the best substance to use in such cases when it can be applied promptly, but the tests showed sawdust to be superior.

LIGHTING UP LOCOMOTIVES.

OIL has come to the help of steam in the case of the invention of Messrs. J. Armstrong and W. Rogers, of the Great Western Railway locomotive department. It is claimed that by its use much of the time occupied and all the smoke nuisance of the present practice of lighting up locomotives may be avoided. According to the Journal of the Royal Society of Arts, the apparatus is mounted on wheels, to stand at the foot of the cab, and consists of two cylinders, the upper one for oil, and the other, immediately underneath it, for compressed air. A tube connects the latter with the top of the former, a cock being fitted to admit enough air to force the latter through a flexible hose fitted with a non-return valve leading from the bottom of the oil cylinder to the nozzle of a small sprayer, which is inserted through the fire door.

The injector has a small central nozzle with an annular jet of compressed air surrounding it. The sprayer is also provided with an atomizer formed by two circular discs, one of which has a boss formed on it, so that when the other disc is attached an annular space is left. This space allows the vaporized fuel to whirl round the nozzle when the injector is working. Each disc has a number of small holes drilled at such an angle that the jets converge on the central axis and thoroughly atomize the oil. The oil readily ignites and covers the dead coal on the fire-grate with flame. The cheapest crude oil, oil gas tar, coal tar or other residuals may be used.



THE DIESEL ENGINE.

THE increasing demand for semi-Diesel engines during the past 12 months has had the effect of bringing more hot-bulb engines on to the market, and has given manufacturers confidence to turn out solid injection sets of much higher power. It is, indeed, safe to assume that the air injection semi-Diesel will go out, and that only the solid injection model will be built. Time was when it was considered imprudent to build a solid injection hot-bulb engine of over 100 b.h.p., but it has now been conclusively proved that proper combustion for powers up to 500 b.h.p. and over can be obtained without the use of air blast, and that the power of the semi-Diesel is not really restricted by the system of fuel injection, but really by such details as the cooling of the pistons, etc.



"I say try, for if we never try we never succeed."—Abraham Lincoln.

Where and Where Not to Use a Continuous Oil System

By Chas. W. Byers

In these days when every cent saved in the operation of a plant is looked upon as an attainment of greater efficiency, manufacturers are beginning to catch the drops of oil which hitherto, after performing their work of lubrication, were allowed to flow away to waste. Every drop is being caught, put through a cleansing process, and sent back to go through the work of lubrication again. This article deals with the practicability of this system.

ALMOST every manufacturing concern uses lubricating oil. A power plant will use more than a laundry. Both use engines and machinery, and if the plants are of any size, they should use oil all the time. There should be a constant supply of oil passing between parts that cause friction. To have this, there must also be a circulating system, and to give greater economy the oil must be filtered before being used a second time.

Manufacturing plants are striving to eliminate production losses, and the greater their success in this direction, the better are they able to meet competition. No company can long subsist which tolerates factory wastes. As friction in the case of steam fed lubrication is only a sixth of that in the case of hand-fed lubrication, it can easily be seen what economy is effected by the installation of an oil filtration and circulating system.

To cleanse and purify oil, several systems are in use. Later on an attempt will be made in this article to describe an apparatus made and used in this country, which, because of its perfectness, will be in great demand by manufacturers before long. We refer to the oil filtration and circulating system made by S. F. Bowser & Co., 66-68 Fraser Avenue, Toronto, Ont.

To make use of precipitation to the fullest extent, would require too much time to be practicable. The oil would need to be in a state of perfect rest. In the case of filtration, time is a secondary matter. Perfection is not reached by either method. In the case of precipitation, the oil might be relieved of its impurities if allowed to stand perfectly still for ten years or more. Perfection is not required. If the oil after going through the process is good enough to use, and lubricates the surfaces satisfactorily, then that process is good enough so long as it is quick and convenient.

The Intermittent System

In what is known as the "intermittent" system, the oil is allowed to stand perfectly still to allow precipitation to occur. Finer impurities will be eliminated by this method than by the circulating systems. The oil is not agitated, and arrangements for draw-

ing off the clean oil must not interfere with precipitation.

Precipitation will remove impurities that cannot be removed by a filter. In fact, if it were not so slow, precipita-

tion restored to expedite the work.

What are the impurities to be contemplated with? Frictional heat darkens oil, but the loss of its color does not

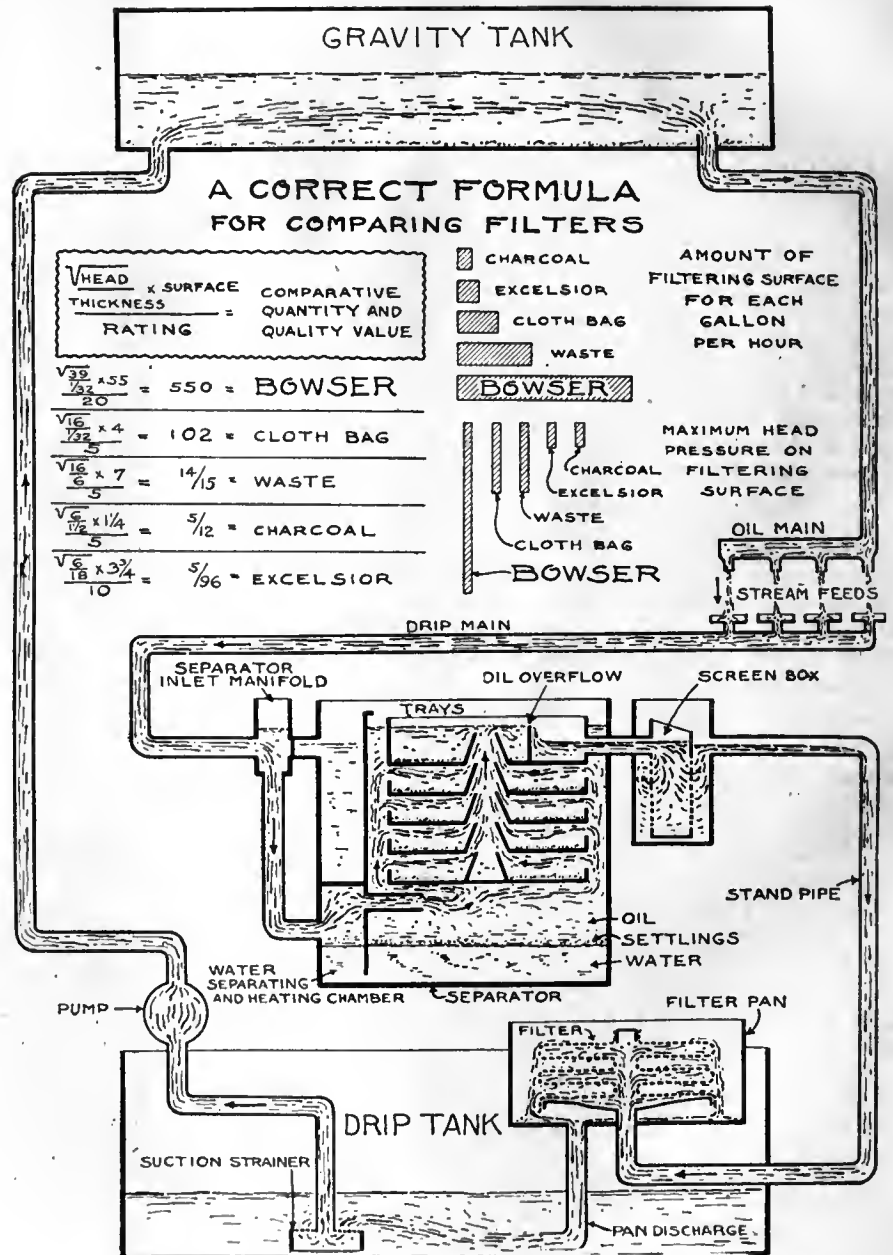

FIG. 1. THE BOWSER OIL FILTRATION AND CIRCULATING SYSTEM.

tion as a means of cleaning oil would be far superior to the other. Then as much of the impurities as possible should be removed in this manner in a

affect the oil's lubricating properties. The oil carries infinitely small dark particles in suspension, which stay in suspension for a long period. This is not

a gritty substance, and does not injure a journal. It is a sort of lamp black, and the only objection to it is that it blocks the oil passages. It is therefore necessary to remove it. Fine surface filters are necessary, and the amount of lamp black removed from the

provided to allow the oil-coated drops to descend.

Right and Wrong Methods.

Let us consider several methods adopted for purifying and clarifying oil. In plants with drip pans at the machines

the drips. In the morning, run the top oil into the filter, allowing an hour to pass through. Nine hours will be taken up in emptying drips into settling tanks at different times, and fourteen hours are allowed for precipitation. Thus a semi-continuous filter is obtained, instead of an intermittent filter.

Lubricating Horizontal Turbines.

Now we will consider machines that contain within their own base considerable quantity of oil, which they recirculate over the bearings for a period of time, and then discharge the entire quantity of long used oil and obtain a like quantity of clean oil, the dirty oil to be clarified and later used again. This is a class of service to be found in the lubrication of horizontal steam turbines. It is also suited for engines which contain a large quantity of oil in the base, and distribute the oil to the bearings by the "Splash system." It also applies, in possibly a smaller way, to ring oiled bearings as used on electric motors, generators, and sometimes line shafting.

The actual condition as found in practice is that where a high grade in-

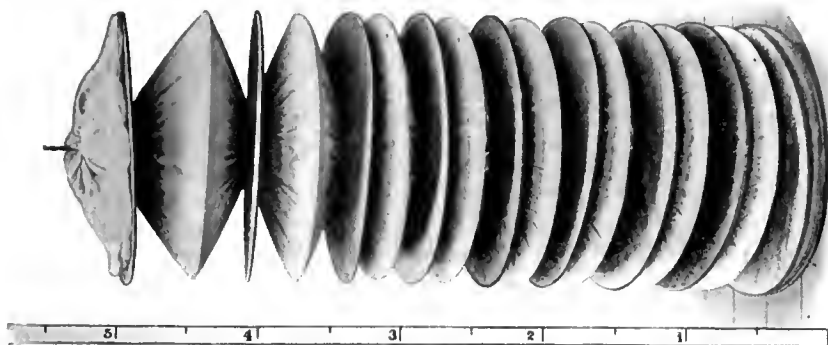

FIG. 3. THE FILTER EXTENDED.

oil depends on the amount of filtering surface.

Getting Rid of Grease.

To eliminate grease, parafin and animal fats from oil, a low temperature filter is absolutely necessary. To remove these substances, they must be cooled before passing through the five interstices of the filter. Then grease is slimy, and necessitates a large filtering surface, so that considerable oil may be run without the filters requiring to be cleaned.

Water is an impurity in oil. It is of two varieties: free water, which precipitates, and water broken into drops which are coated with oil. The more water is kept away from flowing oil, the

which are emptied once a week, a filter is used, the oil flowing into the clean oil compartment. Impurities are precipitated in this compartment, because time was not given them to precipitate anywhere else. The filters do the rough work, and while the oil is standing, precipitation takes place.

This might be improved on by using

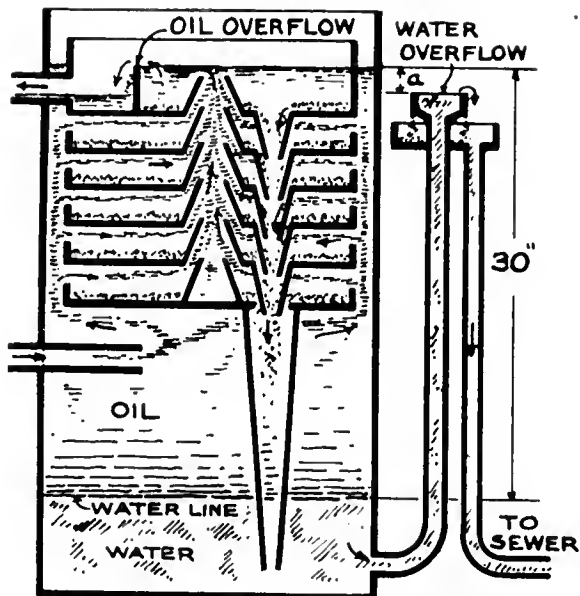

FIG. 2. HOW THE OIL PASSES OVER THE TRAYS.

less will be the amount to be eliminated. Wherever water exists as an impurity, agitation should be avoided, and means

the precipitation tank as a receptacle to receive the drips at any time during the day. Before shutting down, heat

intermittent precipitation and filtering system is used, the oil is vastly cleaner after it is clarified than is possible with

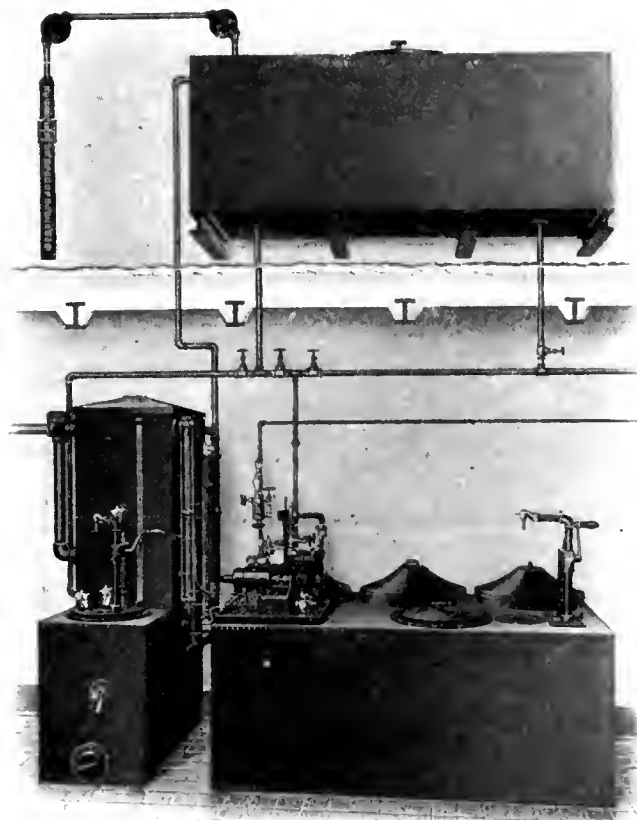

FIG. 4. BOWSER SYSTEM, WITH THREE FILTER SECTIONS.

a continuous system; and when the oil is delivered back to the intermittent system to be reclarified, it is even then in better shape than the best quality obtainable from a continuous system.

In regard to filtration while the turbine is out of service; this requires a small continuous system which will start filtering soon after oil is received. It requires only a filter and an oil storage for the filtered oil. The entire duty is imposed upon the filter, and only

ring oiled bearings; if the oil is to be removed and filtered, the intermittent filter may be used, as there is no reason why oil from the various receptacles cannot all be handled at regular intervals, say, once a week, and secure excellent precipitation.

Engines that are enclosed and depend upon splashing or throwing the oil to a higher elevation where it can flow back to the journals are compelled to re-use dirty oil. Not only does the dirty oil

say that if it were possible to feed positively an excessive amount of clean oil to all bearings of an automobile engine, it would prolong the life of the engine from two to three times what it is with the present system of re-using dirty oil. Many of the engine builders who formerly employed the splash or "self-oiled" system upon their engines, have abandoned this haphazard method, and are using the definite and far more efficient method of delivering filtered oil to each journal through a sight, which permits separate regulation for each feed. This is a class of service where the continuous return drip filtering system is vastly superior to any hand methods that can be employed, regardless of whether the oil is quite as clean as would be obtained from an intermittent clarifying system. In reducing friction and wear, quantity is the big factor and the quality is second in importance. A stream feed of very dirty oil will cause less friction than to feed new oil in small quantities as is usual with hand feeding.

It may seem to a reader that because an intermittent filtering system is recommended for the horizontal turbine, that it should serve equally as well for a splash system engine. The great disparity in the requirements for these two machines does not prove that the engine cannot be more profitably lubricated with a continuous system, for it is recommended by some engineers to use continuous filtration on turbines, and if any semblance of saving can be made by using it upon a turbine surely there would be no question as to economy on an engine which requires but about 1-20 as much filtering surface, and will be called upon to do so much more active work.

Pumping Oil to Sights.

Engines that are supplied with a pump to circulate a body of oil at the engine, but not having the oil clarifying arrangements, are compelled to be re-users of dirty oil. There are quite a few engines of this type which have a pump driven by the engine, in which the oil is delivered to separate sights for each journal. This is a more expensive construction for the engine builder, but it is well justified over the indefinite splash system. This system is provided with a small drip box containing a small wire screen, but no adequate provision is made for keeping the oil in a condition that is profitable to use.

There are two ways of clarifying the oil for such systems, the more common one being a small hand operated filter arranged to take the entire contents of the drip box. The fact that the filter is always found necessary to make this

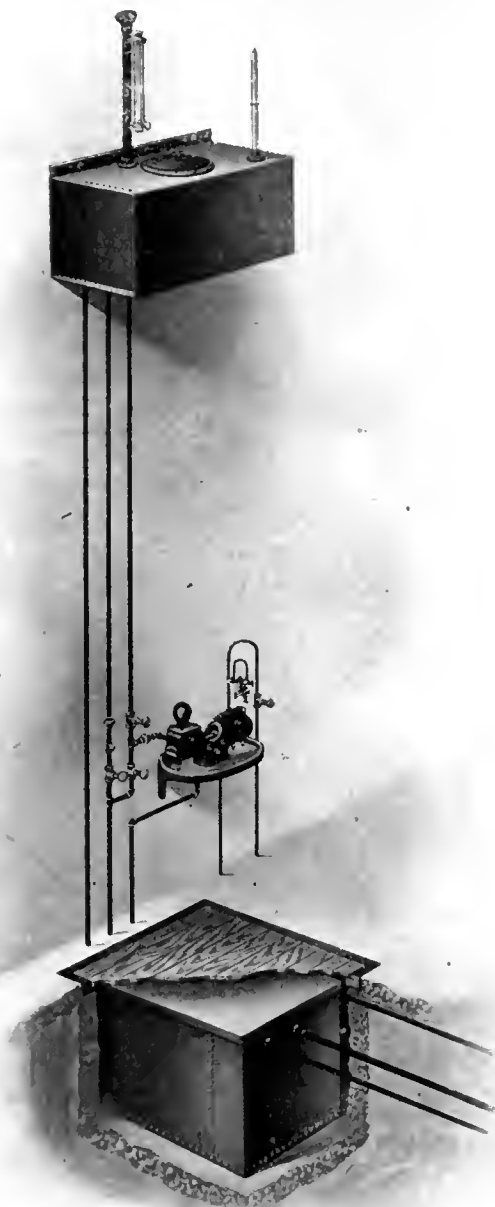

FIG. 5. A SMALL TYPE OF FILTER.

partial clarification is possible. The small amount of additional equipment necessary to make this an intermittent system—one which would have a dirty oil setting tank preceding the filtration—is too slight to tolerate the losses occasioned by improperly clarified oil.

Splash Lubrication.

In regard to clarifying the oil from engines using splash lubrication, also

cause serious wear, but it carries impurities that may close the feed to some bearing, and cause serious injury. Whether this oil be occasionally filtered or not, this method of feeding oil to the bearings is a very bad method, its only merit being its simplicity and cheapness. The automobile engine is possibly one of the best examples of this system of lubrication, and it is safe to

system operative is sufficient proof that it should have been a complete filtering and circulating system at the start. The small pump attached to the engine is never accessible when the engine is in service, and there is no reserve capacity whatever. The moment the pump goes out of service, the oil supply ceases.

To equip with an adequate filtering and circulating system, if there is but one engine, it may be sufficient to instal only the larger dripp receiving tank, gravity tank and filter, using the plunger pump and all the piping on the engine. If there are two or more engines, each having its own pump, it should be possible to place a three-way valve in the pump discharge, and provide a complete return drip filtering and circulating system.

Ring Oiled Bearings .

Ring oiled bearings necessitate the re-use of dirty oil. There are many such bearings that should be connected

in no case does the system of ring oiling serve the purpose of a continuous system.

For rolling mill engines and engines in dirty localities, subject to extreme temperature variations and sometimes incompetent help an oiling system was until recently looked upon as too much of a refinement for such rough service. As a rule, however, they now realize that where the service is so severe, the best aids procurable for keeping the engines in service is what they should have. They have learned that stream oil feed is an extremely important factor, and their present problem is to find what is the best to be obtained to maintain this highly desirable condition.

crease until the entire mass is the smoothest kind of a grease "dope," as difficult a material to filter out as can well be conceived. An intermittent filter must be extremely fine to remove an appreciable amount of the pigment. If the filtering surface is so fine as to completely remove the discoloration, the labor and renewals become so costly that little profit is derived from its reclaiming.

In deciding upon whether the gas engine shall receive oil from cups fed by hand or from a stream feed supplied from a continuous system, there is no question that the latter is vastly the more economical and satisfactory in more ways than one. Where it comes

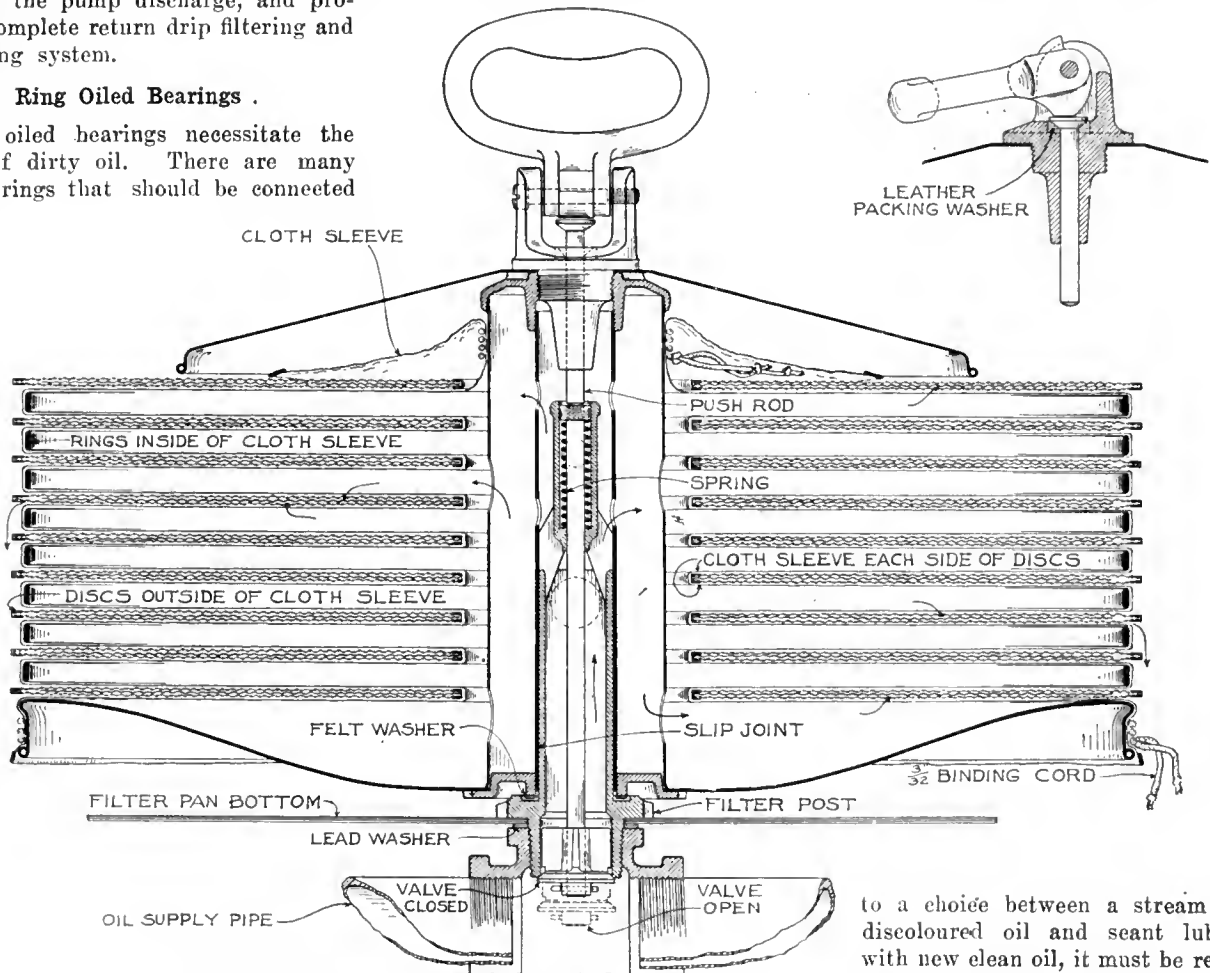

FIG. 6. CROSS SECTION THROUGH A "BOWSER" FILTER.

to a continuous filtering and stream feed system. Ring oiling can be applied to almost any journal, and the mere fact that the rings are on does not alter the duty imposed upon the journal under consideration. For ring oiled bearings that show excessive heat and wear due to extremely heavy duties or much dust and dirt, there is but one alternative, and that is to feed an abundance of clean cool oil. Ring oiling is vastly superior to oiling from a hand oil cup, for in such cases the machine is liable to get no oil of any kind. But

Oil for Gas Engines.

The oil from the crank case of gas engines is difficult to clarify in a manner that is profitable to maintain. The intermittent filter which allows a considerable time for settling is the most effective filter, but by the use of this filter, the oil is much more difficult to clarify. When oil is retained in the crank case and continuously re-used, the impurities are ground down into such a fine pigment, that there is virtually nothing left but color. The impurities, however fine they may be, in-

to a choice between a stream feed of discoloured oil and scant lubrication with new clean oil, it must be remembered that quantity has more to do with elimination of friction than quality, as long as no abrasive substances are present.

Bowser Circulating Systems.

S. F. Bowser & Co., of Toronto, make oil filtration and circulating systems in various types. The 2F type is a straight gravity feed system. The oil flows straight from the tank to the journals, with a gravity drip return from the journals down through the oil clarifying devices to the storage or drip tank, in which the several filter sections are placed.

Roughly the course is as follows, which can be seen by reference to the diagram of the system: from the feeds, the oil passes by gravity to the separator. As it enters this apparatus, it is heated and allowed to settle. The top oil is drawn up over a series of trays, and overflows at the top into a screen box. The velocity over these trays is low increasing as the oil reaches the upwardly projecting cones. The sediment in the oil is collected on these trays.

On leaving the trays, the oil goes to the filters, of which there may be two, three, four, five, six, eight, or ten. These are in filter pans, the oil being forced upwards through them, flowing over into the pan discharge and to the drip tank, whence it is pumped through a strainer back to gravity tank, and supplied again to the journals.

A feature of the Bowser filter is the large surface it contains, there being three square feet of surface for each gallon of oil filtered per hour. Our illustration shows the filter section extended, which gives an idea of the amount of filtering surface. Each section is a complete filter. The cloth sleeve has a circumference of 60 inches, and is 12 feet 10 $\frac{3}{4}$ in. long. It is gathered together like an accordion. The cloth is of very loose woven material, but on account of the system having such a large filter surface, and great head pressure, it will retain the capacity for four months. The muslin does not require cleaning often, but when it does, it can be removed with ease.

The 3F type is the lowest priced gravity drip return gravity supply system. The drip and gravity tanks are each fitted with float gauges, which show the amount of oil in the tanks. It lacks some of the advantages of the 2F type, but affords an opportunity to equip with the latest oiling system..

A Smaller Type.

Sometimes the construction and arrangement of power plants cannot be accommodated to either the 2F or 3F type systems illustrated and described above. There are plants having no basement and without means of draining such a pit as would be required for the 2F and 3F types. In order to meet such conditions the firm have designed a 4F type.

The engine may be so located that a sufficient amount of "fall" cannot be obtained to permit drips to flow by gravity through the clarifying arrangements; consequently, a drip tank is sunk through the floor, which receives the dirty oil. It is equipped with a steam pump, which elevates the oil to the separator and filter sections contained

in the overhead tank, and provides the necessary head pressure and storage.

The chief difference between the system and the 3F type is the reverse position of the tanks, and a consequent reversion in operation. So far as the work is concerned, this system will be found quite as satisfactory as the other. It is capable of filtering the same amount of oil, and furnishes a proper supply of oil to the oil mains. It has been designed as a last resort where no basement or pit is possible, and shows conclusively the flexibility of these systems. This type is not quite so convenient in getting to the filter sections as the one just explained, but for quality of work will be found entirely satisfactory.

This type has shown its adaptability in such plants as those of the Steel Co. of Canada who recently installed one of these in the rod mill and billet mill at Hamilton, Ont. The City of Saskatoon is at present having a 2F apparatus installed in their power house.



ECONOMIC CONDITIONS FOR LIQUID FUEL.

CONCERNING economic conditions of using liquid fuel, many of these are worn almost threadbare, but it may be well to enumerate a few, because coal under any condition is admitted to be a dirty, wasteful and variable means of raising steam and providing power, and, therefore, although the oil costs more initially, there are many compensations to be gained by its use.

Primarily, coal is costly to handle compared with oil fuel. The consumption of oil is perfect, provided due care in the design of the apparatus is taken. There is neither smoke nor smell; no ashes; no waste in starting up or shutting down; its calorific value may be taken as 50 per cent. better than coal, perfect and instant control of the fires may be obtained, they can be started off or shut down at a moment's notice, and, unlike all coal fires, no fuel is expended and no heat is lost when the oil fuel supply has stopped.

All boilers of whatever types are available for the use of liquid fuel without any modification of the arrangement of the furnace as used for coal, except in some special cases. In the case of industrial process furnaces, oil fuel will sometimes do three times the work of coal. Much depends upon the design of the furnace, and too much attention cannot be given to this important matter.

The important improvements which have been effected in the fire brigades of some of the leading cities are owing to the adoption of liquid fuel. So infinite are the uses to which liquid fuel can be

put, and in many instances the economies which can be effected are so striking when every aspect of the question is studied, that the relative value of oil fuel versus coal cannot be decided hastily by a mere comparison of the relative cost of the two fuels. The relative cost of the fuel alone is the chief consideration of most business men, who overlook the important factor of cheaper production and more of it and time saved.

In Foundry Practice.

In foundry practice the use of oil fuel will reduce the time taken to dry large cores to one-third of the time which it takes to do the same work with coal or coke. Thus, there is not merely the time saved on the operation to be considered, but the all-important factors of the speed with which moulds can be ready, castings completed and goods dispatched, far outweigh every consideration of the cost of fuel. On the assumption that a foundry floor is available 1 $\frac{1}{2}$ times as often owing to the employment of liquid fuel for the purpose mentioned, the cost of the fuel hardly counts, as it is over-shadowed by the many advantages gained. There is not a process where heat is required where the operation of heating cannot be more rapidly accomplished with oil fuel than with coal, and the absolute control over the temperature, the absence of smoke, smell, soot, and clinker, are all points in favor of liquid fuel, and for the healthier conditions of working which its employment makes for.

In many of the metal trades, such as the bedstead and bicycle tube factories, the number of sheets of metal spoiled in the rolls owing to the plates being imperfectly heated are considerable. Coal fires are ever-irregular, despite careful attention, but the automatic oil fires would ensure that every unit was uniform, and the percentage of wasters would be reduced to a trifling amount. In the reduction of certain ores, absolute control of temperature is the great factor, and oil fuel could be used here with advantage. From what has been said, therefore, it will be patent that the economic advantages of oil fuel are not entirely dependent upon the difference of price between this source of power and coal, and there is little doubt that when transport facilities are available, the present price of residuum oil will readily decline, as it is only natural to expect that the producers are only shipping the better paying products, that is to say, the motor spirit and kerosene distillates, whilst there must necessarily be large quantities of residuum stocked at the wells pending arrangements being made for its transport.

MACHINE SHOP METHODS ^A_N^D DEVICES

Unique Ways of Doing Things in the Machine Shop. Readers' Opinions Concerning Shop Practice. Data for Machinists. Contributions paid for.

UTILITY OF STANDARD JIG DESIGN.

THE adoption of a system of standard designs is of much advantage in the drawing office, because many hours may be wasted in this department while finding how some particular job has been made. Again, when a draftsman starts work in a new place many days sometimes weeks are spent, unprofitably for the firm, because it is necessary that he become familiar with the practice of the latter. Recourse must necessarily be had to the chief each time uncertainty arises and due to his other duties, the latter is not always available. Further, the checker whose duty it is to see that everything is correct, often

contain an index, preferably a sectional one.

Drilling Jigs.

The drilling jig is one of the earliest methods in the line of appliances for the manufacture of duplicate parts. In its simplest form it is merely a plate with hardened steel bushings corresponding with the holes to be drilled. Other types are known as box jigs, these being used where holes are drilled in all or nearly all sides of the work. The one important factor of jig design is to make sure that they will be absolutely rigid, otherwise they will become distorted when clamping the piece, or when under the thrust of the drill. On the other hand they should be as light as possible,

that all the drills will be well lubricated. Where large pieces have to be drilled,

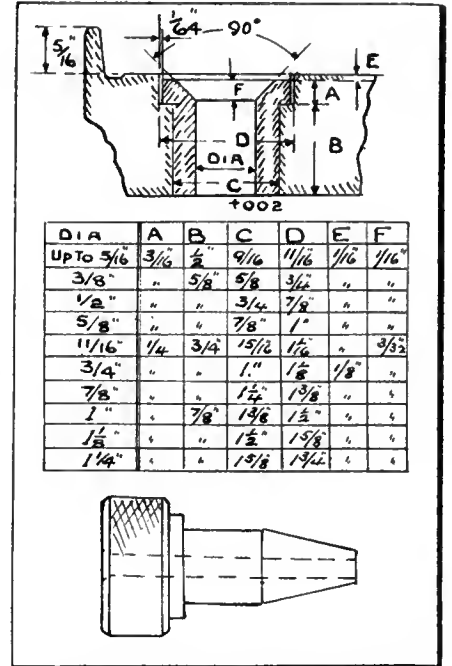

FIG. 2. BEST TYPE OF BUSH FOR MULTIPLE SPINDLE WORK.

such as crank-cases for engines, etc., which contain many holes on all sides, a large and heavy jig then becomes necessary, and were it convenient to mount

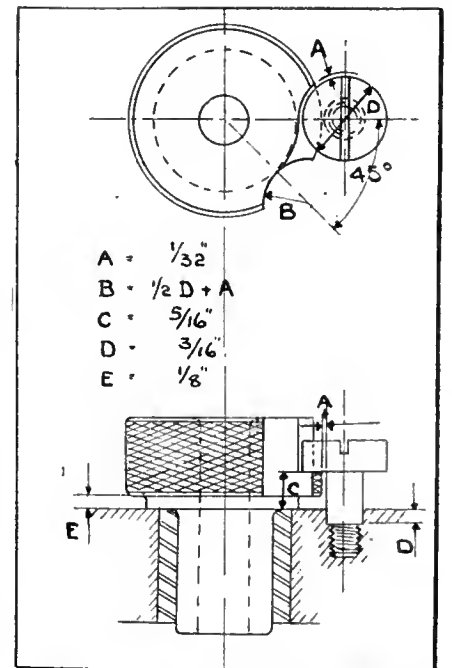

FIG. 3. DESIGN OF SLIP BUSH.

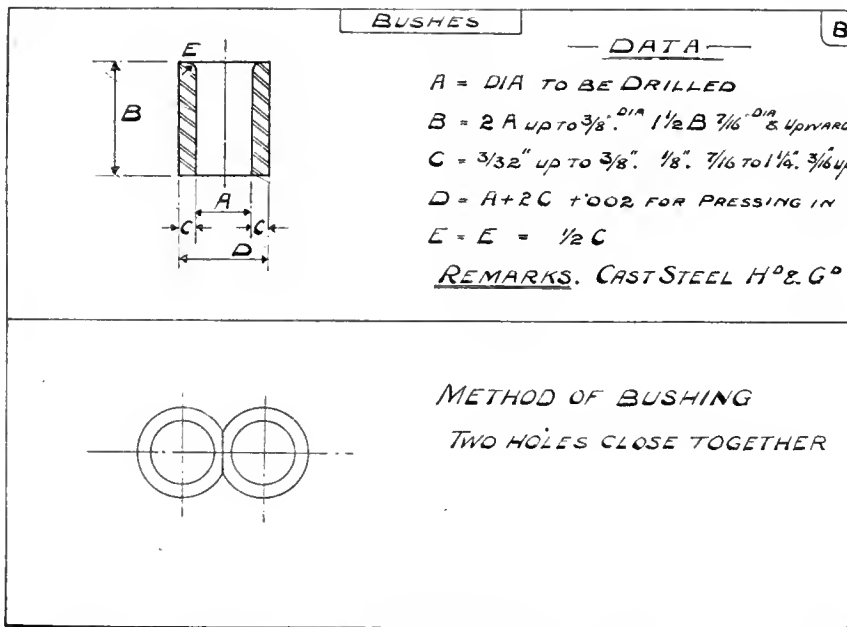

FIG. 1. COMMON FORM OF DRILL BUSH.

spends hour after hour, needlessly, altering drawings, much or all of which might be saved by some standard data available and which could be placed in the hands of each newcomer immediately he starts. Were a book of standard designs prepared, its usefulness would not end with the drafting room, but would become of the greatest service in the tool room and other sections of the factory.

A convenient size for a standard book would be 11 x 8 1/2 inches. It should be constructed of fairly good, smooth paper, so that drawings and data may be inked in. A good binding would be necessary, otherwise, it would get damaged by constant use. It should

so that they can be easily handled by the operator.

Very rapid advancement has been made in the development of the multiple spindle drilling machine, it being possible to drill the full number of holes in one operation, of which the number of spindles on the machine is capable. These machines are used to advantage on work where holes have to be drilled and afterwards reamed. A 12-spindle machine is set up with six drills and six reamers; it is thereby possible to drill a piece and ream the holes by simply sliding the jig along the table. By this means much time is saved. In designing jigs for these machines, the one important point is to make provision so

such a jig on trunnions, it could be revolved readily to either side.

Illustrated in Fig. (1) is the common form of drill bush with a useful standard and a method of bushing two holes close together. It also shows how to use the standard book already mentioned. In Fig. 2 is shown the best type of bush for multiple spindle work, there it will be noticed that same is sunk below the surface level. By this plan the drill gets its full share of lubricant. Where possible, it is best to cast a bead around the top of the jig, thus forming a trough which can always be kept full. Referring again to the bush, it can be used to advantage in other jig designs. Fig. 2 illustrates a very common arrangement of slip bush, but for high speed work it gradually pulls out and causes constant trouble.

A much better, although more expensive design of slip bush is shown in Fig. 3. This ensures absolute accuracy, for the bush will maintain its full bearing until the hole is drilled. It is also very easily operated. Careful note should be made of the holding down screw and the method of sinking below the face, for it cannot be broken off at the screw by rough usage as would be the case if it were not sunk in. Where two holes are together, one screw can be made to suit two bushes.

Sometimes it is necessary for bushes to hold down the work in which case, there is a right and wrong way of designing them. In Fig. 4 is shown the best method, with the ground portion nearest the work and the screw at the top; the bottom of the threads being of a greater diameter than that of the location, which enables the grinding wheel to pass clear. Only three threads should be intact, more being unnecessary. The other bush shown in Fig. 4 is to accommodate the pilot of the reamer, although this is not always necessary. Wherever possible, provision should always be made at the bottom of the bushes to allow chips to fall clear. This will save many drills.

The most important consideration in jig design is the selection of the locating points. These must be determined with due reference to any tendency to distort the work, and with particular reference to the locating points for the same piece in the fixtures of milling machines, etc. If this element is not properly considered, the relationship between the drilled holes and other machine cuts will not be accurate.

ELECTRIC LOCOMOTIVES.

WITHIN the next few years hundreds of miles of railway in the north-western United States will be operated by means of electric locomotives.

Already arrangements have been completed for electrifying some 450 miles of the Chicago, St. Paul and Puget Sound Railway, and it is stated that the company has appropriated \$7,500,000 for this work.

The electric locomotive has already shown marked efficiency on the mountain railways. As a matter of fact, the limit of capacity of a number of American lines has long been determined in large measure by their ability to get trains over some of the excessive grades on their mountain sections. From two to five steam locomotives of the heaviest type are required to haul trains over these grades, and a speed of seven or eight miles an hour is seldom exceeded. Where such grades pass through tun-

ing together a pair of these 90-ton electrics, both under the control of one man, the engineer has under control 3,500 horse-power, or a maximum tractive force of 90,000 pounds. One of the huge Mallet steam locomotives weighs 239 tons, but of this weight only 167 tons is on the drivers and the engine is, therefore, capable of only 71,000 pounds tractive effort.

The electric locomotive has undoubtedly proved its worth, and a few years will see them largely used not only on the mountain roads of the United States, but of Canada as well. This constitutes still another reason for the people retaining control of hydro-electric development.

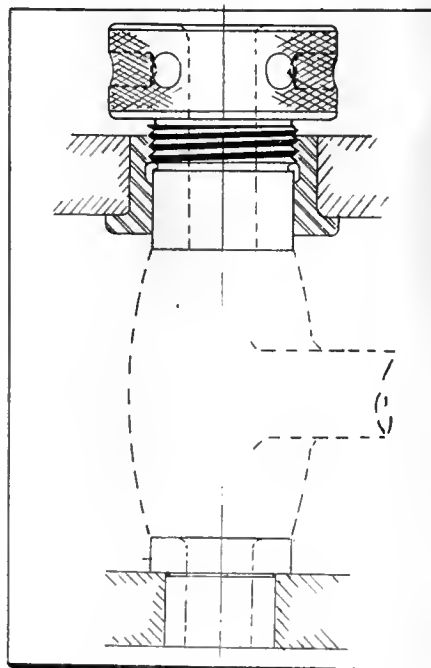

FIG. 4. BUSHES TO HOLD DOWN THE WORK.

nels the difficulty is increased, for the steam and smoke from the locomotives coats the rails with a greasy soot, which makes the wheels slip, and the heavy fumes from the coal or oil fuel make operation a matter of real danger to the train crews.

With the installation of electric locomotives all the difficulties and dangers arising from soot have been overcome, and trains are hauled over these portions of the road at double the best speed possible for steam. The 100-ton electric locomotive is suitable for the heaviest railway traffic, and one of them will "back" the heaviest steam locomotive.

For the handling of freight trains there are electric locomotives that weigh 180 tons, and which have a traction power of 80,000 pounds starting. The motors are built in two sections, each of which weighs 90 tons. By plac-

HOW TO PREVENT NEEDLESS FIRE WASTE.

PASS ordinances making the fire department a department for the prevention of fires as well as the extinguishment of fires.

Give the police department authority to prevent fires, and make each man responsible for the proper enforcement of preventive measures.

Institute in the public schools a course of regular weekly instruction in the economic significance of fire waste.

Investigate the cause of every fire, and punish the person or persons responsible for the conditions causing the fire, whether the fire was incendiary or from carelessness or indifference.

Popularize individual responsibility.

Educate the public; have a "Fire Prevention" day.

By carrying out these recommendations, a material reduction in Canada's \$2,000,000 a month fire waste would be brought about.—The Bulletin.

STEEL CONCERN WOUND UP.

UPON the petition of Mr. Robert Heath, of Stafford, Eng., the owner of 1,945 shares in the Provincial Steel Company, Limited, of Cobourg, an order for the winding up of that concern was made by Mr. Justice Latchford at Osgoode Hall April 6. Mr. G. T. Clarkson was appointed interim liquidator, and a reference was made to the Master in Ordinary. The company was incorporated in 1908, with a nominal capital of \$250,000, of which \$230,000 is said to be paid up. Although the liabilities are said to be \$227,674.85, it is claimed the assets exceed this by over \$125,558. The Standard Bank was said to be a creditor to the extent of \$132,032, on an overdraft, but to hold notes of the nominal value of \$70,000 as collateral. The Provincial Steel Co. have a rolling mill at Cobourg.

DEVELOPMENTS IN MACHINERY

A Record of New and Improved Machinery Tending Towards Higher Quality and Economical Production in the Machine Shop, Blacksmith Shop or Planing Mill.

AUTOMATIC TOP AND BOTTOM DOUBLE SEAMER FOR IRREGULAR SHAPES.

SHOWN in the accompanying illustration is a new double seamer recently put on the market by the E. W. Bliss Co., Brooklyn, N.Y. The machine is for double seaming in one operation both ends of square, oblong or oval cans. It has a capacity for cans up to 8 inches square and 15 inches high. The speed of operation depends to some extent on the shape of the work. Oblong cans, about 3 in. by 8 in., may be produced at the rate of 12 per minute; square or oval shapes can be double seamed at considerably increased speed.

The closing movements of the chucks and the operation of the clutch and brake are performed by power under control of a single foot treadle, which requires but a slight pressure, and allows the operator to work while sitting down. This arrangement constitutes a valuable improvement in that the operator is relieved of the work of moving heavy parts requiring considerable force in spite of whatever counterweighting may be employed. The chucks are bolted directly to face plate gears on the ends of spindles. This allows of a short connecting or driving shaft,

which in connection with the very liberal proportions employed throughout and steady action of the machine has

sure account being kept of all stamps used, the latter being automatically recorded by the counter which is inset in the machine. No skilful manipulation is needed to operate the apparatus. A coil of stamps is put into place and locked, then, by depressing the knob, a small quantity of water is sprayed from three jets on to the envelope. The stamp is fed into position by the perforations, and is cut off, recorded, and pressed on to the envelope on the downstroke of the handle, after which it springs back into the normal position ready for the next operation. When not in use, the mechanism may be locked so that it cannot in any way be tampered with.

The whole machine is a thoroughly practical mechanical device of first-class finish throughout and is manufactured by W. H. Banfield & Sons, die and press makers, Toronto.

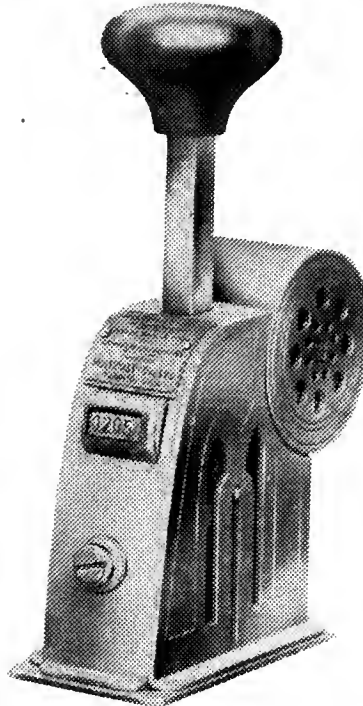

STAMP AFFIXING MACHINE.

effectually eliminated the not uncommon defect of twisted cans. The feed cams are driven by spiral gears from the spindles. The rocker shafts and arms are in one piece, thus giving a strong and positive action. The drive is by bevel gear through a friction clutch and brake.

Adjustment for different height cans is made by the hand wheel on the upper head, which operates a lifting screw. In adjusting for different cans, it is often necessary to turn the machine slowly. This has usually been done by having an extra man to turn the driving pulley at the back of the machine. To do this in the machine shown a hand wheel is provided in convenient position for use by the operator. The hand wheel is geared to the driving shaft, a tumbler gear being provided and interlocked with the main clutch to prevent the gears coming in mesh when using power. The weight of the machine is 3,100 pounds.

STAMP AFFIXING MACHINE.

THE stamp affixing machine here illustrated makes possible not only the rapid handling of mail, but also en-

AN IMPROVED GATE VALVE.

THE extensive use of the valve here with illustrated has demonstrated that its durability and efficiency are fully appreciated by steam users. It can be had entirely of brass, of iron body brass mounted, of "puddled" semi-steel, or of cast steel.

As seen by the illustrations, the valves are made in two forms—one with stationary stem and the other

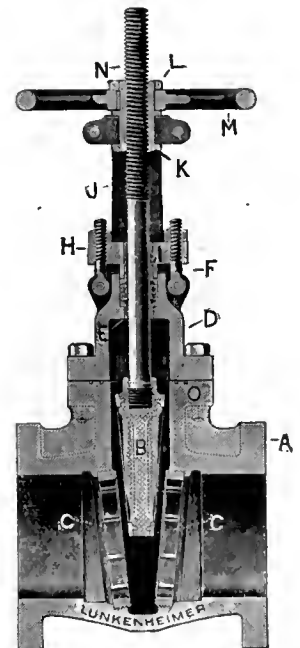

IMPROVED GATE VALVE WITH OUTSIDE SCREW AND YOKE.

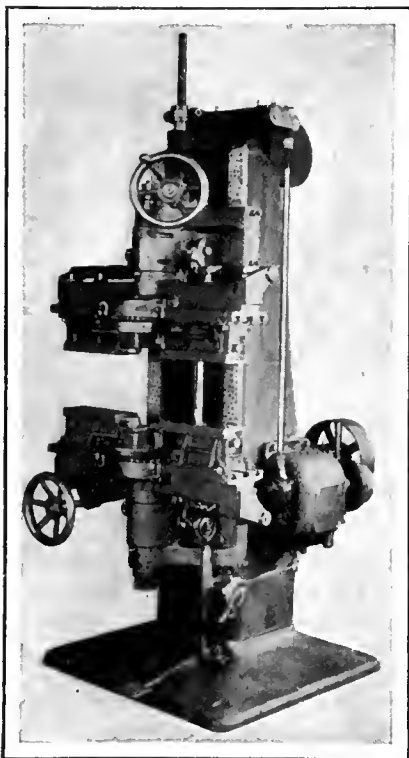

NEW DOUBLE SEAMER.

with outside screw and yoke. The seat rings, as well as the wedge disc, can be renewed when worn, thus making the valve as good as new. A desirable feature in the construction of the valves is the fact that when finishing the interior of the valve body, that portion which receives the seat rings is threaded to the correct angle of the tapers of the valve disc. The seat rings are threaded and faced off straight, and when screwed in place, they fit accurately to the tapers of the disc. This consequently makes it possible to easily renew the seat rings, should they become worn or broken.

The discs in both forms of valves are made entirely of bronze up to and including the 6-inch size on the medium, heavy and extra heavy patterns, and up to the 3½-inch size in the standard pattern. Above this they are made of iron with bronze face rings. As the valves are double seated, they will take pressure from either end. Either pattern of the gate valves can be packed under pressure when wide open. The stuffing box in the valve with stationary stem is made of bronze, and is tightly screwed into the hub.

The joint between the body and hub is worthy of attention, being practically indestructible. It consists of grooves cut in the top surface of the valve body, in which are placed seamless copper gaskets. The yokes and hubs are rigidly held to the body by large steel bolts, both the heads and nuts of which seat on spot-faced surfaces. The valve can also be had with exterior by-pass, a detailed view of which is shown.

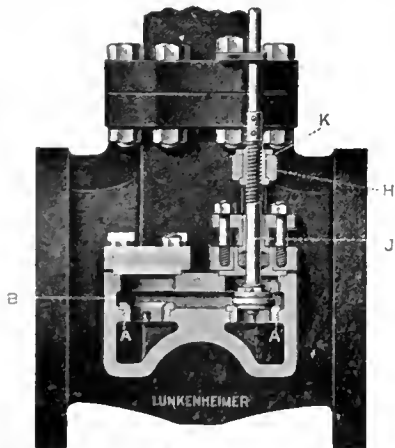

IMPROVED GATE VALVE—DETAIL OF BY-PASS.

The by-pass used is not separate from the valve proper, but is cast integral with the body, as will be seen by the illustration, and this method has many points of excellence. The additional metal required for the by-pass tends to strengthen the valve body, and, being self-contained, it is not affected by extremes of expansion and contraction.

The Lunkenheimer Company, of Cincinnati, Ohio, are the manufacturers of this valve, and the patentees of the im-

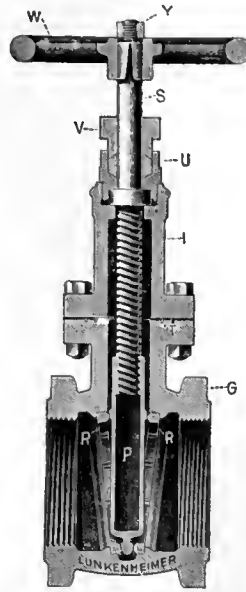

IMPROVED GATE VALVE WITH STATIONARY STEM.

proved form of by-pass used. They have given the valve the trade name of "Victor."



Trade Gossip

The Joseph Dixon Crucible Co., Jersey City, N.J., have just published a new booklet entitled "Graphite for the Boiler." It, of course, deals with no new discovery, for graphite has been sold for scale removal purposes from boilers for many years; simply, stating in as few words as possible the salient features of this product. No startling claims are made, for the subject is too old to be longer sensational.

Information for Investors.—Pigeon, Pigeon & Davis, Patent Solicitors, 71a St. James St., Montreal, report that 167 Canadian Patents were issued for the week ending April 23, 1913, of which 104 were granted to Americans, 29 to Canadians, 23 to residents of Great Britain, and 11 to residents of foreign countries. Of the Canadians who received Patents, 9 were residents of Ontario, 5 of New Brunswick, 4 of Quebec, 4 of British Columbia, 3 of Saskatchewan, 2 of Manitoba, 1 of Alberta, and 1 of Nova Scotia. In the United States, for the same week, 529 Patents were issued, 12 of which were granted to Canadian Inventors.

The Federal Graphite Mills, Cleveland, Ohio, have issued a booklet entitled "Actual Experiences of Engineers with Boiler Graphite." Inserted in the booklet are to be found leaflets containing instructions and suggestions

for operating and cleaning steam boilers with "Federal Graphite"—the name by which the firm's product is known, and also information relative to the daily costs of treatment. All operating engineers are interested in the subject of boiler scale prevention, and such data as is made available through the medium of the above-mentioned literature may be acquired and practised by all who care to avail themselves of it.

The Platt Iron Works Co., Dayton, O., manufacturers of pumps, feed water heaters, water wheels, etc., whose plant suffered some damage from the recent flood at Dayton, is now prepared to accept and fill all orders promptly. The company's buildings were practically uninjured, and the second day after the water subsided, steam was got up, the service and fire pumps put in operation, and the work of removing the mud and debris was started. The entire organization responded most loyally towards getting the plant going again, irrespective of the fact that many of them suffered personal loss due to the flood. A small portion of the plant was put in operation on April 7, but because a large number of the machine tools are equipped with individual motor drives, it was necessary to bake and clean these motors, therefore, the company did not start up in all departments until April 21.

Graton & Knight Mfg. Co.—In accordance with its policy adopted a number of years ago the Graton & Knight Manufacturing Co., of Worcester, Mass., well-known oak leather tanner and belt makers, recently held a salesmen's convention at its main factory in Worcester. This convention was attended by the company's salesmen from all parts of the country, and the various sessions were devoted to an inspection of the factory, to a study of methods of manufacture, as well as to the sale and application of the company's products. At the conclusion of the convention a banquet was served at which more than 100 officers, salesmen and other employees were present. A feature of this year's meeting which was especially inspiring to those in attendance was the presence of Henry C. Graton, founder of the business. To a very large extent, the phenomenal growth of the business, from a small belt shop in 1851 to a plant that is one of the largest of its kind in the world, is to be attributed to the sagacity and wisdom of Mr. Graton and his early associates, and to the persistent adherence of the firm to the policy early adopted of endeavoring to meet the steadily increasing demands for the most serviceable leather belting.

The MacLean Pub. Co., Ltd.

(ESTABLISHED 1838.)
 JOHN BAYNE MACLEAN - - - - - President
 H. T. HUNTER - - - - - General Manager
 PUBLISHERS OF

CANADIAN MACHINERY
 AND MANUFACTURING NEWS

A weekly newspaper devoted to machinery and manufacturing interests, mechanical and electrical trades, the foundry, technical progress, construction and improvement.

H. V. TYRRELL - - - - - Business Manager

OFFICES:

- | | |
|---|---|
| CANADA | GREAT BRITAIN |
| Montreal, Rooms 701-702 East-ern Townships Bank Bldg. | London, 88 Fleet Street, E.C. |
| Toronto, 143-149 University Ave., Phone Mala 7324 | Phone Central 12960
E. J. Dodd |
| Winnipeg, 34 Royal Bank Bldg., Phone Garry 2313 | UNITED STATES |
| Vancouver, H. Hodgson, 2640 Third Ave. West. | New York, R. B. Huestis, 115 Broadway, New York, N. Y., Phone 2209 Rector |
| | Chicago, A. H. Byrne Room 607, Marquette Bldg. 140 S. Dearborn St., Chicago |

CABLE ADDRESS:
 Macpubco, Toronto. Atabek, London, Eng.

SUBSCRIPTION RATE:

Canada, \$2.00; United States, \$2.50; Great Britain, Australia and other colonies, 8s. 6d. per year; other countries, \$3.00. Advertising rates on request.

Subscribers who are not receiving their paper regularly will confer a favor on us by letting us know. We should be notified at once of any change in address, giving both old and new.

Vol. IX. MAY 14, 1913 No. 17

PRINCIPAL CONTENTS.

New Plant of the Pease Foundry Co., Ltd., Brampton, Ont.	507-511
Vanadium in Locomotive Springs	511
The Proposed Workmen's Compensation Act	512-513
Methods Adopted for Avoiding Fire in a Factory.....	513-515
The Growing Plant of a Canadian Clotch and Pulley Firm.....	515-517
General	517
Ball Bearing Line Shafts....Sawdust a Fire Extinguisher Lighting-up Locomotives The Diesel Engine.	
Where and Where Not to Use a Continuous Oil System.....	518-522
Economic Conditions for Liquid Fuel	522
Machine Shop Methods and Devices	523-521
Utility of Standard Jig Design....Electric LocomotivesHow to Prevent Needless Fire Waste....Steel Concern Wound Up.	
Developments in Machinery	525-526
Automatic Top and Bottom Double Seamer for Irregular Shapes....Stamp Affixing Machine....An Improved Gate Valve.	
Trade Gossip	526
Editorial	527
Industrial and Construction News	528-530
Engineering Electrical Waterworks Municipal....Woodworking....Building Notes General Industrial.... Railways, Bridges.... Marine....Contracts Awarded....Tenders....Trade Gossip Personal Obituary....Catalogues.	
Selected Market Quotations	531-532
The General Market Conditions and Tendencies	532

BE READY FOR THE FLOOD WHICH IS COMING.

THERE is a tide in the life of every nation which, if taken at the flood, leads on to fortune. This paragraph of Shakespeare's famous dictum is applicable to us. It is as true of the nation as of the individual. There are many who recall the coming of the tide in Germany and, strange to say, it came with a bloody war. Following the struggle between France and Germany there was a tide of unheard-of prosperity, which was taken at the flood and landed Germany among the great manufacturing countries of the world. The United States has witnessed many a tide and many a flood, the waves of which carried

her farther and farther ahead. There came times of depression, it is true, when the waters receded, but they never went back. The same might be related of Japan.

Opportunities come to all nations, and careful observers will see a tide in Canada, and the flood is not far distant. We seem to have reached a point, in spite of clouds which overhang, where a mighty effort is required from men within our boundaries; the chance is here, now, to make Canada a mighty nation. When opportunity occurs, if those on the ground do not realize it, others from afar will rush in to pull the plums.

So far we seem to have been concerned with preliminaries; doing things on a small scale; making our requirements in a make-shift fashion. If we put a thing together it was by having the parts brought to us, and thus, instead of having big manufacturing concerns, we have assembling rooms. A tremendous market has been growing, and firms across the line have been erecting assembling rooms here with incredible rapidity. Look around and see the hundreds of plants in this Dominion which are merely erecting shops, whose real manufacturing is done elsewhere.

A departure from this state of things is becoming urgent, and that's the flood which will one day sweep this northern continent. The first marked indication of it is in the turning of sod for the gigantic steel plant which the United States Steel Corporation is erecting at Sandwich. We had occasion the other day to inspect a large engineering plant on the Niagara Peninsula, where enormous steel plates were required as well as small ones. "Where do you purchase these?" we inquired. "The large ones come across the line," was the reply, "but the smaller shapes are rolled in Canada. But when the big plant is erected at Sandwich, we shall purchase all our steel within the Dominion."

Up to the present there has been no demand for these large plates in Canada, sufficient to warrant the erection of mills capable of turning out big stuff, but the necessity has arisen, and one American concern has thought it worth while to lay out the money. It is up to Canadian capitalists to see that they are not left behind in this matter, and that when the flood does come, they will have the necessary equipment to supply the goods.

In view of this, the responsibility which rests on the Government is a heavy one. For political and patriotic reasons they have seen fit of late to belittle Canadian ability and possibilities. In other words, they are trying to stem the tide which is coming this way. Their duty is to pave the way for it by fostering the industries that have struggled here for years against great odds, and now require some help to prepare for the great trade which is bound to come.

There is a tendency to slacken down in an effort to secure more and more emigrants. The cry of 'Canada for the Canadians' is rank foolishness, when manufacturing concerns all around us are planning to expand, and fear to do it because skilled mechanics are wanted and are not available. We have heard of several large manufacturing concerns this week who are far behind with deliveries through scarcity of help. And if there is to be any slackening on the part of the Immigration Department, it should be in the direction of agriculture, to allow a greater effort to be made to bring out Britain's expert mechanics, instead of so many undesirable 'handy men.'

A Montreal plant was shut down recently for a week because a wheel broke. In Canada the facilities for supplying parts are wretched. We are merely a bundle of erecting shops, without foundries and the wherewithal to make parts. It is here where the change will be effected; it is here where the flood will pass.

INDUSTRIAL ^A_N^D CONSTRUCTION NEWS

Establishment or Enlargement of Factories, Mills, Power Plants, Etc.; Construction of Railways, Bridges, Etc.; Municipal Undertakings; Mining News.

Engineering

Hamilton, Ont.—The Canadian Drawn Steel Co., are preparing plans for considerable additions to their plant.

Welland, Ont.—Robt. Turnbull has purchased ten acres of land including a brick yard from D. D. Hooker, and intends to locate a steel industry on it.

North Sydney, N.S.—The machine shop of R. Musgrave was destroyed in a big fire on May 4. Kirk & Cook, contractors, lost all office effects and plans.

Montreal, Que.—Plans are being prepared for the erection of a warehouse at a cost of \$10,000 for the Phoenix Bridge & Iron Works, 83 Colborne Street.

Factoria, Sask.—The Saska Mfg. Company, an implement manufacturing company, with a capital stock of \$200,000, will locate here, and will be operated by P. S. Houghton.

Brantford, Ont.—Mr. Charles Brown and others have secured an option on the Farmers Binder Twine Co., and will manufacture hay-presses and other machinery on a big scale. A company is being floated now.

Sarnia, Ont.—The Harrower Machine Works has been absorbed by the Lough-eed Co. Considerable extensions will be carried out between now and the fall. The firm will specialize in marine work.

Winnipeg, Man.—The Manitoba Bridge & Iron Works advises a foundry building, 60 x 178 feet, has been completed, equipped with electric cranes and all other necessary machinery, to be used as a jobbing shop.

Ogden, Alta.—The C. P. R. shops were recently inspected by Geo. Bury, vice-president, who stated that the shops will be used only for repairing engines and rolling stock, and not for construction of new locomotives or cars.

Saskatoon, Sask.—The factory of Stameo, Ltd., commenced manufacturing iron beds last week. The side rails and posts are received from other points, so that very little manufacturing is done. E. V. Hives is the manager.

Goderich, Ont.—The by-law authorizing authorities to guarantee bonds of the Rice-Knight Co. for \$20,000 was carried last week. The firm manufacture brass fittings in Toronto at present. Electrical fittings will be manufactured at Goderich.

Grimsby, Ont.—A by-law will shortly be submitted to the ratepayers asking for permission to lend money to the Canadian Steel Specialty Co., to aid them in establishing a factory for the manufacture of bent steel furniture in Grimsby.

Stratford, Ont.—The ratepayers have authorized the city to guarantee the bonds of the Stratford Mill Building Co. for \$30,000, and grant other concessions. The company manufacture flour mill machinery, and will build a \$60,000 plant.

Gravenhurst, Ont.—The Canadian Steel Specialty Company, manufacturers of steel furniture here, will locate at Grimsby, Ont. The company is a going concern and the only one of its kind in Canada. It asks the town for a loan of \$10,000.

Quebec, Que.—The Dominion government are looking for a site on which to erect the eastern shops of the Trans-continental Railway, and it is reported that the Quebec city council has made an offer of exemption of taxes for 20 years or more if the shops are erected at St. Malo.

Newcastle, N.B.—The Canadian Gear Works, Ltd., recently incorporated have taken the Lamont factory on McCullum St., which will be renovated and some additions made. Wagon gears and bodies will be the principle product. There will also be a planing mill. Joseph Ander, accountant of Newcastle, is one of the directors.

PLANT SITE BEING STUDIED

Geo. A. Edgin, purchasing agent and Asst. Supt. of the Duff Mfg. Co., Pittsburgh, Pa., was in Toronto early this week looking for a site on which to erect a Canadian branch factory. The Duff Mfg. Co. make Barrett lifting jacks, and recently built a plant in Pittsburgh which covers two acres. They are, however, a firm with thirty-five year's experience in Pittsburgh.

Their business in this country amounts to nearly \$100,000, and is so considerable they have been contemplating coming here for two or three years. Mr. Edgin informed us that he would locate in some town between Montreal and Windsor, and would require about two acres of ground, of which he would use from 10,000

to 15,000 square feet. He would also prefer to be somewhere near a malleable iron plant, and for that reason has paid considerable attention to Brantford.

The firm intend to build a plant giving employment to about fifty men to start, consisting of a machine shop and erecting shop. If suited they would commence operations some time this year. They are not looking for bonuses, and do not expect anything for nothing. If available they will be quite willing to lease a ready made factory, as temporary premises. Mr. Edgin has already traveled over the road from Windsor to Toronto, and is proceeding to Montreal, calling at the towns en route.

Electrical

Saskatoon, Sask.—The city will run a power line to Factoria, principally to supply 250 h.p. to the Northland Milling Co., who are building there.

Victoria, B.C.—The British Columbia Electric Co. will build a big wharf at Brentwood Bay. It will be 250 feet in length. A new sub-station will also be erected on Richmond Hill to cost \$74,000.

Calgary, Alta.—Work now under way on the Calgary street railway system will give the city 77 miles of track and 90 street cars. The system will satisfy the city's requirements until it has a population of over 100,000.

Dawson City, Yukon.—The power house of the Dawson Electric Light

Power Co., was burned to the ground on Saturday, May 3rd with a loss of \$200,000. A temporary electric service was established later.

Dryden, Ont.—By-laws have been passed authorizing the expenditure of \$2,500 for a telephone system; \$2,500 for water power development and \$6,000 for acquiring an electric light system from the Dryden Lumber & Power Co., Ltd.

Montreal, Que.—The Montreal Board of Control has decided to widen and deepen the water works aqueduct to generate additional power for pumping and lighting purposes to supply the city. Ten thousand horsepower will be developed, of which 6,000 will be utilized for pumping and the rest for lighting the city. The present pumping station will be remodelled. The scheme will cost about \$5,000,000. Plans for the electrical equipment will be prepared later.

Water-Works

Victoria, B.C.—The city intends to extend the plant of the Sooke Waterworks.

Woodstock, Ont.—The ratepayers have voted in favor of a proposition to provide \$12,000 for extensions of water mains.

Port Coquitlam, B. C.—The citizens were asked on May 14th for permission to spend \$10,000 for the purpose of constructing a waterworks.

Newmarket, Ont.—At a recent meeting of the town council, Reeve Pierson announced that he would shortly introduce a by-law dealing with waterworks.

Brandon, Man.—By-laws will be submitted to the ratepayers shortly authorizing the expenditure of \$10,000 for water meters, and \$7,000 for bridge purposes.

St. Rose, Que.—An action has been taken to prevent the Standard Construction Co. from accepting a contract to perform construction work on an aqueduct and on sewers.

Fredericton, N.B.—The Fredericton Gas Co. will erect a pumping station on the bank of the St. John River. They will install pumping machinery, and a steam turbine. Luke S. Morrison is manager of the company.

Municipal

Strassburg, Sask.—The British Canadian Engineering & Supply Co., Winnipeg, are endeavoring to secure the town's order for an electric light plant.

Regina, Sask.—The city is building an industrial building for small new industries.

Ottawa, Ont.—The city is building a new gas plant on Lees Ave. The foundations are just being erected.

Ottawa, Ont.—John Coates, a consulting engineer of London, Eng., will report on the establishment of a municipal gas plant, he is now in British Columbia reporting on a similar matter there.

Calgary, Alta.—The city will immediately spend \$320,000 on a 5,000 kilowatt generator and boilers, and a building capable of housing a 15,000 kilowatt plant costing \$100,000. R. A. Ross, engineer, Montreal, is being consulted.

Quebec, Que.—Three hundred and nine municipalities have made application for improved highway, seventy-four of which have been ratified. The sum required for this work will exceed \$3,000,000, and will amount to about 400 miles of Macadamized highway.

Berlin, Ont.—A meeting of the municipal representatives of Berlin, Waterloo, Preston and Hespeler has been called to discuss joint action in securing an extension of the present natural gas mains from Galt. The meeting was called by D. B. Detweiler, of Berlin.

Wood-Working

Neustadt, Ont.—The ratepayers will shortly vote on a proposition to loan money to the Neustadt Furniture Co.

Quebec, Que.—The Quebec Harbor Commission have decided to erect an up-to-date saw mill at Indian Cove.

Winnipeg, Man.—The J. Arbuthnot sash and door factory was burned to the ground on May 12, the loss amounting to \$20,000.

Nolalu, Ont.—The sawmill owned by Jaeke Jones, was destroyed by fire recently. He intends to rebuild on the old site at once.

Vancouver, B.C.—The Red Cliff Lumber Company's sawmill on Roebuck Point has been purchased by the Vancouver Lumber Company and work will be resumed immediately.

Preston, Ont.—Plans are being prepared for an addition to the Canadian Buffalo Sled Company's factory at Preston, Ont. The building will be 60 x 60 ft., two stories of concrete construction.

Sarnia, Ont.—Hector McFee has purchased from Geo. A. Proctor a carpenter's shop and other property, which he will remodel and equip with modern

machinery for carriage factory. He will also erect a new brick factory on the vacant property.

Quebec, Que.—The Labrador Pulp & Lumber Co., is extending its operations at Hamilton Inlet, Que. The company have now in operation two large saw mills, and have started on the construction of a pulp mill with a capacity of 60,000 tons a year, they will also erect a mill at Sandwich Bay with a capacity of 50,000 tons.

Building Notes

Weyburn, Sask.—The Provincial Government will build a court house here costing \$80,000. The architects are preparing plans.

Montreal, Que.—Building permits issued at the City Hall for the first nine days of May totalled \$612,455. The largest amounts were made up of the permit for the Montreal Light, Heat & Power Building on St. Urbain Street, for \$220,000; the building for the Commission Scholaire de Gaspé for \$95,000, with about half a dozen other permits for sums ranging from \$10,000 to \$15,000. The remainder were for smaller sums.

General Industrial

Windsor Mills, Que.—On May 4th the wheel mill of the Canadian Explosives Co. was blown up, one man being killed.

Nelson, B.C.—Wallace Craven & Herbert Craven have placed orders for machinery to be used in a cement brick plant.

St. Catharines, Ont.—The B. F. Goodrich Rubber Co., of Akron, Ohio, advise that they have not definitely decided to locate at Chippawa.

Delhi, Ont.—The Delhi Mitt & Glove plant was totally destroyed by fire April 29. The loss is \$25,000 to \$30,000, partly covered by insurance.

Lake Megantic, Que.—The ratepayers have authorized the granting of bonuses to a broom factory, and the owners of the proposed Asseline Woollen Mill.

Goderich, Ont.—A by-law providing for loan of \$4,000 to Dietrich & Sons was defeated last week. The company propose to erect an \$8,000 wood woollen factory.

Montreal, Que.—The Atlas Glass Works, Ltd., will start operation about June 15th at St. Pierre, Blue Bonnets, employing 700 skilled men. It will have a yearly capacity of about \$1,000,000 worth of glass ware. Mr. David Pugh is the managing director.

Welland, Ont.—The Welland Electro Plating Co., opened up last week on 78 Patterson Ave., a general jobbing business being done. H. Hopwood is manager and H. D. Hesch, Secy-Treasurer.

New Hamburg, Ont.—Mr. Schnefer, brick and tile manufacturer of Breslau, Ont., has formed a joint stock company here to purchase sixty-five acres of land. They will erect a \$75,000 plant.

Renfrew, Ont.—The Renfrew Electrical Co. have started to build a factory measuring 110x40 feet, with a side addition of 20 x 40, two storeys high. They will manufacture electrical irons, toasters, heaters, radiators, etc.

Rosthern, Sask.—The Rosthern Brick Co. are installing new machinery in order to double their output. It is now 20,000 bricks a day. The new machinery ordered includes an engine, boiler, truckmill conveyor, and a 200 gal. pump. O. A. Welk is the yard manager.

Thorold, Ont.—The Ontario Paper Co.'s plant will be in operation in July, and immediately preparations will be made for additions. At first the mill was to have a capacity of 125 tons of paper a day. Of this the Chicago "Tribune" consumes 80 tons alone.

London, Ont.—The London Pressed Brick & Tile Co., Ltd., with a capacity of \$100,000 have acquired clay deposits near London, and have let contracts for machinery with the Berg Machinery Co., of Toronto to be installed early in July. This plant will have a capacity of 22,000 bricks per day.

Belleville, Ont.—The Eastern Rubber Co., Ltd., are negotiating with this town regarding the establishment of their plant here. They will employ 150 hands to start, to be increased to 500 later. John J. Main is managing director and A. G. Gamble and Thomas W. R. Blowers are other officers.

Vancouver, B.C.—The assets and good-will of the Brackman Ker Milling Co., in Alberta and British Columbia, have been acquired by the Western Canada Flour Mills, Ltd. The deal involves about \$1,000,000. It is proposed to enlarge the Calgary mill immediately to a capacity of 1,500 barrels daily.

Trenton, Ont.—The large canning factory of Miller & Co., a branch of the Dominion Cannery was burned to the ground on the night of May 11th, while the Barr Register Co., manufacturers of cash registers, was also burned out. It is estimated that \$100,000 will be the loss to both plants. Both were insured. The former company employed about 150 men and the latter 30.

Winnipeg, Man.—The local elevator and milling firm of Davidson and Smith announce that they will build at Port Coquitlam a duplicate of the cleaning elevator and flour mill, that they will construct in Port Arthur. Each elevator will have a cleaning capacity of sixty thousand bushels a day, and a drying capacity of ten thousand bushels. The mills will have a capacity of 2,500 barrels of flour a day. Each plant will cost \$650,000.

Ingersoll, Ont.—On May 28th the rate-payers will vote on a by-law authorizing the town to grant a loan of \$20,000, and other concessions to the Standish Mfg. Co., of Toronto, makers of washing compounds. The company is to erect a two-storey brick and cement building at least 40 x 100 feet, which, together with the equipment is to be worth at least \$30,000. They are also to employ from 40 to 50 hands and are to begin to repay the loan after the first year.

Trade Gossip

Calgary, Alta.—The city have awarded a contract for a new municipal laboratory to Johnstone & Johnstone for \$2,075.

The New Hamburg Manufacturing Co. works are contracting with Wettlaufer Bros., of Stratford, to make 50 cement mixers.

Montreal, Que.—The C.P.R. is in the market for 20 more electric motors, from 5 to 50 h.p. Engineer. Mr. Baer, Angus shops.

Montreal, Que., the Canadian metropolis, is falling into line with other cities, and is about to engage a publicity commissioner.

St. Mary's Ont.—The St. Mary's Cement Product Company, Water St., contemplate purchasing additional cement machinery at a cost of \$25,000.

Toronto, Ont.—The capital stock of the Walkerville Light & Power Co., Ltd., has been increased from twenty-five thousand dollars, to one hundred thousand dollars.

The Consumer's Gas Co., of Toronto, has been authorized to extend its works and pipes and exercise its powers within the townships adjoining the limits of the city of Toronto and the limits of the Township of York.

Vancouver, B.C.—The city has awarded a contract for 300 fire hydrants to the Robertson-Godson Co., agents for the Kerr Engineering Co. The price was \$39.25 for plain hydrants and \$67 with crane attachments.

Personal

Geo. B. Wilson has been appointed street commissioner in Toronto.

J. H. Moffat, for the past twelve and a half years head designer at the MeLagan Furniture Factory, Stratford, Ont., has accepted the position as superintendent of the Gibbard Factory at Napanee.

E. C. Jenkins, for years associated with the Aylmer Iron Works and later with the present company, the Aylmer Pump and Seale Co., has received appointment as office manager of the Fleury works in Aurora, Ont.

J. A. Leishman has been appointed to the post of engineer in charge of the Western division of public works for the city of Montreal, and Westmount loses one of her most able officials. Mr. Leishman, who far over a year has been assistant engineer in Westmount, taking charge of construction work on paving, sewer laying, etc., has had wide experience in the engineering world. For twelve years he was with Messrs. Thomas Nesbitt & Co., of Glasgow, Scotland, specializing in road paving. He came to Canada three years ago.

Obituary

Hugh Reid, sen., member of the firm of Reid & Brown, structural steel and ironworkers, Esplanade, Toronto, died May 11, at his home, 55 Chestnut Park road, after a brief illness. Born in Glasgow, Mr. Reid had lived in Toronto 45 years, and had been in business as Reid & Brown for thirty years. He had a large business connection.

Daniel Simonds, president of the Simonds Canada Saw Mills Co., Ltd., St. Remi Street, St. Henry, died at his summer residence, near New York, May 5. He was 66 years of age, and had been in indifferent health for the past few months; but the news of his death came unexpectedly. Mr. Simonds is survived by his widow and three sons, all members of the Simonds Manufacturing Company: Gifford K. Simonds, Fitchburg, Mass.; Alvan T. Simonds, Lockport, New York; and Haklan K. Simonds, Fitchburg, Mass. The Simonds Manufacturing Co. opened up their works at St. Henry in 1906, together with other works at Vancouver and St. John, N.B. Mr. Simonds took a keen interest in the welfare of the employes of the company, by whom he was held in high esteem, and did much to improve their surroundings. He converted the whole top floor of the Fitchburg works into a recreation club, suitably furnished and fitted up.

SELECTED MARKET QUOTATIONS

Being a record of prices current on raw and finished material entering into the manufacture of mechanical and general engineering products.

FIG IRON.

	Per Ton.	
Foundry No. 1 and 2, f.o.b., Midland	\$19 00	\$19 50
Gray Forge, Pittsburgh	16 15	
Lake Superior, charcoal, Chicago	18 00	
	Mont'l. Tor'to.	
Canadian f'dry, No. 1..	\$21 00	\$20 00
Canadian f'dry, No. 2..	20 50	19 50
Middlesboro, No. 3....	23 50	23 50
Summerlee, No. 2	25 00	26 50
Carron, special	25 00
Carron, soft	25 00
Cleveland, No. 1	24 25	25 00
Clarence, No. 3	23 75	24 50
Jarrow	25 50
Glengarnock	26 00
Radnor, charcoal iron.	30 00	34 50
Ferro Nickel pig iron (Soo)	25 00

BILLETS.

	Per Gross Ton.	
Bessemer billets, Pittsburgh ...	\$28 50	
Open hearth billets, Pittsburgh.	29 00	
Forging billets, Pittsburgh.....	36 00	
Wire rods, Pittsburgh	30 00	

FINISHED IRON AND STEEL.

Per pound to large buyers:

	Cents.
Common bar iron, f.o.b., Toronto..	2.10
Steel bars, f.o.b., Toronto.....	2.20
Common bar iron, f.o.b., Montreal.	2.15
Steel bars, f.o.b., Montreal.....	2.25
Bessemer rails, heavy, at mill....	1.25
Iron bars, Pittsburgh	1.70
Steel bars, Pittsburgh, future	1.40
Tank plates, Pittsburgh, future...	1.45
Beams, Pittsburgh, future	1.45
Angles, Pittsburgh, future	1.45
Steel hoops, Pittsburgh	1.60

Toronto Warehouse f.o.b., Toronto.

	Cents.
Steel bars	2.30
Small shapes	2.40
Warehouse import, freight and duty to pay:	Cents
Steel bars	1.95
Structural shapes	2.05
Plates	2.05

Freight, Pittsburgh to Toronto:

18 cents carload; 21 cents less carload.

BOILER PLATES.

	Mont'l. Tor'to.	
Plates, ¼ to ½-in., 100 lbs.	\$2.35	\$2.35
Heads, per 100 lbs.....	2.65	2.95
Tank plates, 3-16 in.	2.60	2.60
Tubes, per 100 ft., 1 inch	9.00	8.50
“ “ 1¼ in.	9.00	8.50
“ “ 1½ “	9.00	9.00
“ “ 1¾ “	9.00	9.00
“ “ 2 “	8.75	8.75
“ “ 2½ “	11.50	11.50
“ “ 3 “	12.00	12.00
“ “ 3¼ “	13.75	13.75
“ “ 3½ “	14.50	14.50
“ “ 4 “	18.00	18.00

BOLTS, NUTS AND SCREWS.

	Per cent.
Stove bolts	80 & 7½
Machine bolts, ¾ and less	65 & 5
Machine bolts, 7-16.....	57½
Blank bolts	57½
Bolt ends	57½
Machine screws, iron, brass	35 p c
Nuts, square, all sizes.....	4c per lb off
Nuts, Hexagon, all sizes..	4¼ per lb off
Flat and round head.....	35 per cent.
Fillister head	25 per cent.
Iron rivets	60, 10, -0 off
Wood screws, flathead, bright	85, 10 p c off
Wood screws, flathead, brass	75, 10 p c off
Wood screws, flathead bronze	70, 10 p c off

National-Acme "Milled Products."

Sq. & Hex Head Cap Screws	65 & 10%
Sq. & Hex Head Cay Screws	65 & 10%
Rd. & Fil. Head Cap Screws	45-10-10%
Flat & But. Head Cap Screws	40-10-10%
Finished Nuts up to 1 in. ..	75%
Finished Nuts over 1 in. ..	72%
Semi-Fin. Nuts, up to 1 in..	75%
Semi-Fin. Nuts over 1 in....	72%
Studs.....	65%
Discounts f.o.b., Montreal.	

WROUGHT IRON PIPE.

The following are Toronto jobbers' discounts on pipe in effect from April 21, 1913:

	Buttweld		Lapweld	
	Black	Gal.	Black	Gal.
¼ ¾ in.	62	47
½ in.	68	58
¾ to 1½	71½	61½	68½	58½
2 in.	71½	61½	68½	58½
2½ to 4 in. ..	71½	61½	70½	60½
4½ to 6 in.	71½	61½
7, 8, 10 in.	66	54

X Strong P. E.

¼, ⅜, ½ in. ..	56½	46½
¾ to 1½ in. ..	67½	57½
2 to 3 in.	68½	58½
2½ to 4 in.	65	55
4½ to 6 in.	64	56
7 to 8 in.	55	45

XX Strong P. E.

½ to 2 in.	43	33
2½ to 4 in.	43	33

PRICES OF WROUGHT IRON PIPE.

Standard.	Extra Strong.	D. Ex. Strong.
Nom. Price.	Size Price	Size Price
Diam. per ft.	Ins. per ft.	Ins. per ft.
⅛ in \$.05½	⅛ in \$.12	½ \$.32
¼ in .06	¼ in .07½	¾ .35
⅜ in .06	⅜ in .07½	1 .37
½ in .08½	½ in .11	1¼ .52½
¾ in .11½	¾ in .15	1½ .65
1 in .17½	1 in .22	2 .91
1¼ in .23½	1¼ in .30	2½ 1.37
1½ in .27½	1½ in .36½	3 1.86
2 in .37	2 in .50½	3½ 2.30
2½ in .58½	2½ in .77	4 2.76
3 in .76½	3 in 1.03	4½ 3.26
3½ in .92	3½ in 1.25	5 3.86
4 in 1.09	4 in 1.50	6 5.32
4½ in 1.27	4½ in 1.80	7 6.35
5 in 1.48	5 in 2.08	8 7.25
6 in 1.92	6 in 2.86
7 in 2.38	7 in 3.81
8 in 2.50	8 in 4.34
8 in 2.88	9 in 4.90
9 in 3.45	10 in 5.48
10 in 3.20
10 in 3.50
10 in 4.12

IRON PIPE FITTINGS.

Canadian malleable, 40 per cent.; cast iron, 65; standard bushings, 70; headers, 60; flanged unions, 65; malleable bushings, 65; nipples, 75; malleable, lipped unions, 65.

COKE AND COAL.

Solvay Foundry Coke	5.95
Connellsville Foundry Coke	5.45
Yough, Steam Lump Coal	3.83
Penn. Steam Lump Coal	3.63
Best Slack	2.95
All net ton f.o.b. Toronto.	

OLD MATERIAL.

	Tor'to.	Mont'l.
Copper, light	\$12 05	\$11 00
Copper, crucible	15 00	13 50
Copper, unrec'bled, heavy	13 05	12 50
Copper wire, unrec'bled..	13 05	12 50
No. 1 machine compos'n..	12 00	11 00
No. 1 comps'n turnings..	10 00	10 00
New brass clippings	9 15	9 10
No. 1 brass turnings	8 30	7 75
Heavy lead	3 25	3 25
Tea lead	3 00	2 75
Scrap zinc	4 00	3 75
Dealers' purchasing prices.		

METALS.

Prices in cents per pound:

	Mont'l.	Tor'to.
Lake copper	16.25	16.25
Electrolytic copper	16.25	16.25
Spelter	6.00	6.00
Lead	4.70	4.85
Tin	52.00	52.00
Antimony	10.00	9.75
Aluminum	23.00	21.00

SMOOTH STEEL WIRE.

No. 6-9 gauge, \$2.35 base; No. 10 gauge, 6c extra; No. 11 gauge, 12 extra;

No. 12 gauge, 20c extra; No. 13 gauge, 30c extra; No. 14 gauge, 40c extra; No. 15 gauge, 55c extra; No. 16 gauge, 70c extra. Add 60c for coppering and \$2 for tinning.

Extra net per 100 lb.—Spring wire; bright soft drawn, 15c; charcoal (extra quality), \$1.25.

SHEETS.

	Mont'l.	Tor'to.
Sheets, black, No. 28....	\$2 85	\$3 00
Canada plates, ordinary, 52 sheets	2 80	3 00
Canada plates, all bright.	3 70	4 15
Apollo brand, 10¾ oz. (American)	4 30	4 20
Queen's Head, 28 B.W.G..	4 50
Fleur-de-Lis, 28 B.W.G..	4 20
Gorbal's Best Best, No. 28	4 45
Viking Metal, No. 28....	4 40

NAILS AND SPIKES.

Standard steel wire nails, base	\$2 40
Cut nails	\$2 60	2 65
Miscellaneous wire nails..	75 per cent.	
Pressed spikes, ½ diam., 100 lbs.	2 85

FINE STEEL WIRE.

Discount 25 per cent. List of extras. In 100-lb. lots: No. 17, \$5; No. 18, \$5.50; No. 19, \$6; No. 20, \$6.65; No. 21, \$7; No. 22, \$7.30; No. 23, \$7.65; No. 24, \$8; No. 25, \$9; No. 26, \$9.50; No. 27, \$10; No. 28, \$11; No. 29, \$12; No. 30, \$13; No. 31, \$14; No. 32, \$15; No. 33, \$16; No. 34, \$17. Extras net. Tinned wire, Nos. 17-25, \$2; Nos. 26-31, \$4; Nos. 30-34, \$6. Coppered, 75c; oiling, 10c.

MISCELLANEOUS.

	Cents
Putty, 100 lb drums	\$2.70
Red dry lead, 560 lb. caska, per cwt.	6.00
Glue, French medal, per lb	0.10
Glue, 100 flake	0.11
Tarred alaters' paper, per roll...	0.95
Motor gasoline, single bbls., gal..	24½
Benzine, per gal.	23½
Pure turpentine	64
Linseed oil, raw	58
Linseed oil, boiled	61
Plaster of Paris, per bbl.	2.10
Plumbers' Oakum, per 100 lbs....	3.25
Pure Manila rope	17

The General Market Conditions and Tendencies

This section sets forth the views and observations of men qualified to judge the outlook and with whom we are in close touch through provincial correspondents.

Montreal, May 12, 1913.—Deadly dullness again rules, although born of optimism, the machinery brokers and supply houses state that good things are in sight. Where are they is often asked and why so invisible? Nevertheless, there are barometers, and perhaps none better than the attitude of manufacturers such as comprise the Association Membership. At their banquet last week there was no discordant note, and some of the big men stated that they were going ahead to make improvements in facilities because they believed in the future of Canada, the future of the great unpeopled sections and the industries incident thereto. This means that they are not afraid to junk some of their old-fashioned machinery—and by the way some of them have plenty—and go in for new and better plant equipment. A large American machine tool maker told the writer that it was a comfort to their house and others who were trying to sell tools to know of the Canadian prosperity. The tightness of money did not worry them for they knew the resources of the buyers everywhere.

Pig Iron and Copper.

This was Whit-Monday holiday in London to-day, and many of the big dealers here had no market news. Still it was quite understood that if there was anything doing they would have known. The report of Producer's returns for April is being quoted in American papers as being primary indicative of no undue excitement in the copper market. Reduction in surplus stocks is variously accounted for, and none is more frequently used than that of the heavy buying some time ago when prices were low, coupled with abnormal exports. This cannot be expected to continue and especially if there is any truth in the Old Land reports that they are overburdened with shipments from this continent. The market is firm and there is every possibility of an advance according to sound opinion. Any permanency to this strength is problematical and it would be unwise to put too much credence in it. Copper sheets were reported steady in large lots. Seamless copper tubes unchanged. Pig iron passed through another week of dullness. Consumers show keen activity in

the situation and are watching every turn. It is understood that heavy buying on the part of consumers which took place early in the year will tide them over for another month, or maybe more, at least. From foundry quarters it is reported that they have none too heavy stocks and are wondering at the market. Take for instance coke. It has not declined like pig iron, and there is a certain amount of significance in that too. While pig iron does not follow coke, coke often follows pig iron in price declines, and it is said by big operators that curtailment sometimes follows coke when uncertainty lives in pig iron. The latter condition being pronounced one is left to draw conclusions accordingly. Bar iron is strong and active and a fair market is reported. Antimony, spelter, aluminum are reported dull and nominal in every case. In old material, the market is not new in any way, the demand being small and offerings heavy.

• • •

Toronto, May 14, 1913.—There is very little change this week in the condition of the machinery market. Interest was centred in the liquidation sale of the Canadian Gas, Power & Launches, Ltd., at their premises on Dufferin St., early this week. As this was a very large concern and as the whole business including real estate, machinery, material, parts, and eighty-four engines were for sale, all the local dealers were on hand

Plant of the St. Lawrence Bridge Co. Ltd., Rockfield, Que.

By J. H. Williams

The completion of the huge cantilever bridge over the River St. Lawrence at Quebec will perhaps be the greatest engineering undertaking ever accomplished in Canada, and one which will arouse widespread interest. The St. Lawrence Bridge Co., who secured the contract for the superstructure, have erected near Montreal one of the finest and best equipped bridge building plants on this continent, and have now commenced fabrication of the various component parts of the immense structure.

THOUGH most people know in a general way that the Quebec Bridge is a big undertaking, the average man has but a vague idea of the weight and dimensions of the structure. It requires a considerable effort of imagination to realize what an enormous span is represented by 1,800 feet,—more than one-third of a mile. There will be approximately 60,000 tons of steel in the bridge, work on the component parts of which is now going busily forward.

The plant of the St. Lawrence Bridge Co., Ltd., at Rockfield, near Montreal,

moved to the shop on narrow gauge (36-in.) tracks. The storage yard is served by a two-trolley Northern crane of 15 tons capacity. The crane runway is 500 feet long by 90 feet wide.

The Main Building.

The main building is 660 feet long, with an average width of 160 feet and has two elevations. For 400 feet at the west end of the shop the height to the underside of the roof trusses is 21 ft., while over the remainder of the floor the head room is 38 ft. 6 in.

angle milling machine, 7-ft. plate shear, 36-in. single rotary planer, double head angle shear, and 36-in. punch with spacer. There are also two 45-ft. and one 20-ft. plate edge planers fitted with pneumatic clamps.

The second 100-ft. panel is devoted to drilling and punching, the centre columns dividing the two operations. The punching equipment already mentioned presents no unusual features, being of a standard character. But the arrangements for drilling are of considerable interest. There are forty heavy radial

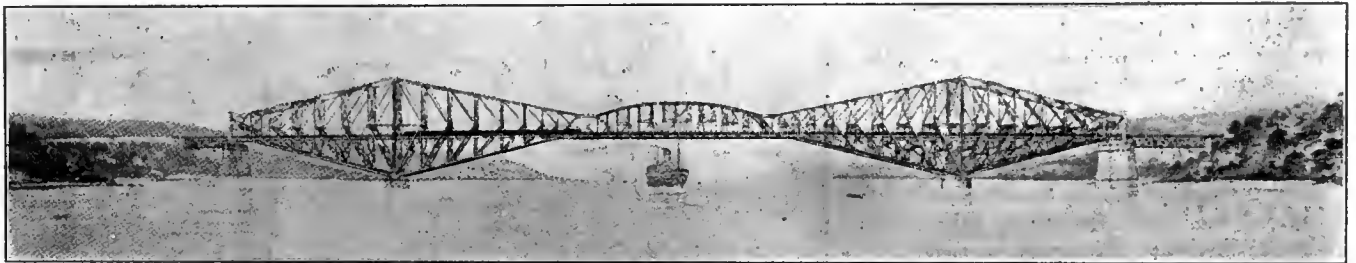

SOUTH END.

QUEBEC BRIDGE.

NORTH END.

is now completed and, as stated, manufacturing has already commenced. As may be seen from the plan on page the plant is of the "straight-away" type the material entering at one end and passing straight through without change of direction. The finished members thus leave the shop at the opposite end to that by which the material entered.

The Stock Yard.

The storage space for rolled material is located at the west end of the plant. Material is delivered to the yard by two standard gauge tracks and is later re-

The first mentioned space is divided into four 100-ft. panels by central columns which support the centre trusses carrying the roof and the crane runways. The first panel of 100 ft.—starting from the west end — is devoted to laying out, straightening, shearing and edge planing operations. Stiffener angles are also crimped and milled here, the floor being served by two 10-ton cranes.

To overcome winter weather conditions, plates are rolled and sheared inside the shop. The equipment here includes 20 ft. rolls, 18-in. punch and shear,

drills, sixteen of which are stationary and mounted on one long foundation, while the remaining twenty-four are of the portable type, each being mounted on an individual truck. These trucks run on portable tracks which can be clamped to the concrete floor at any point. The radial drills all have 6-ft. arms and are driven by variable speed motors.

There are also twenty-four drills of the horizontal type mounted on trucks. These will work in conjunction with the radial drills, and will later be used for drilling the field splices in the main

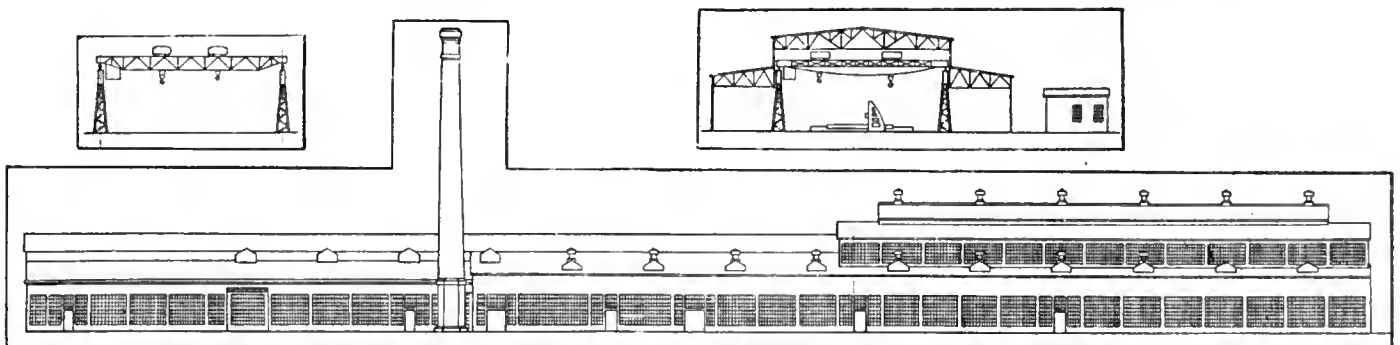

SOUTHWEST AND END SECTIONAL ELEVATIONS.

material in this panel of the shop members. Two 10-ton cranes handle the There are also two 40-ton cranes as it is the intention to drill the material en masse after being temporarily assembled, which will result in having forty-ton sections to handle.

The third 100-ft. panel is used for the storage of drilled and punched material, except for the space occupied by the two manhole boring machines on the south side of the shop. These two machines were built by the John Bertram and Sons Co., Ltd., Dundas, Ont., and will be used to rough-out the large pin holes in the plates previous to assembling. The largest pin hole is 45 inches in diameter, and the smallest 10 inches. This panel is served by two 10-ton cranes.

The fourth and last 100-ft. panel is used for the assembling of members up to 80 tons each and is also provided with portage reaming facilities. Two 10-ton and two 40-ton cranes serve this panel.

Commencing at this point the head room under the roof trusses increases to 38 ft. 6 in., as previously stated, and is divided into two bays of a width of 75 ft. and 85 ft. respectively. The length of this higher portion of the shop is 260 feet and sections weighing over seventy tons will be fabricated in the 85-ft. bay, which is equipped with two 70-ton cranes and one 35-ton. At this end of the shop is a very large floor boring machine, which will be used for boring the large shoes and main members. This machine is motor-driven and has a capacity for boring 45-inch holes through a thickness of 11 feet. The saddle has a vertical movement of 12 ft. 6 in., while the main column has a horizontal traverse of 23 feet, the intention being to drill the several holes in the shoes, etc., at one setting and not disturb the section being bored.

There is a large duplex vertical and horizontal slotting machine for finishing the ends of the large compression members, since the specifications forbid rotary planing. One end of this machine is stationary while the other has power traverse along the bed for the various lengths of material to be finished. The heads cut in either a vertical or horizontal direction for a distance of 10 feet and are equipped with patent tool holders for cutting on all four strokes. The end centre sections of the bottom chords of the bridge, which are to be finished feet high, 42 feet long and weigh 140 tons each. After being finished they will be transferred across to the boring machine by the two 70-ton cranes. Riveting is done in the centre of each bay, the heavy pneumatic riveters being suspended from special traveling wall jib cranes.

Heavy concrete skids all over the

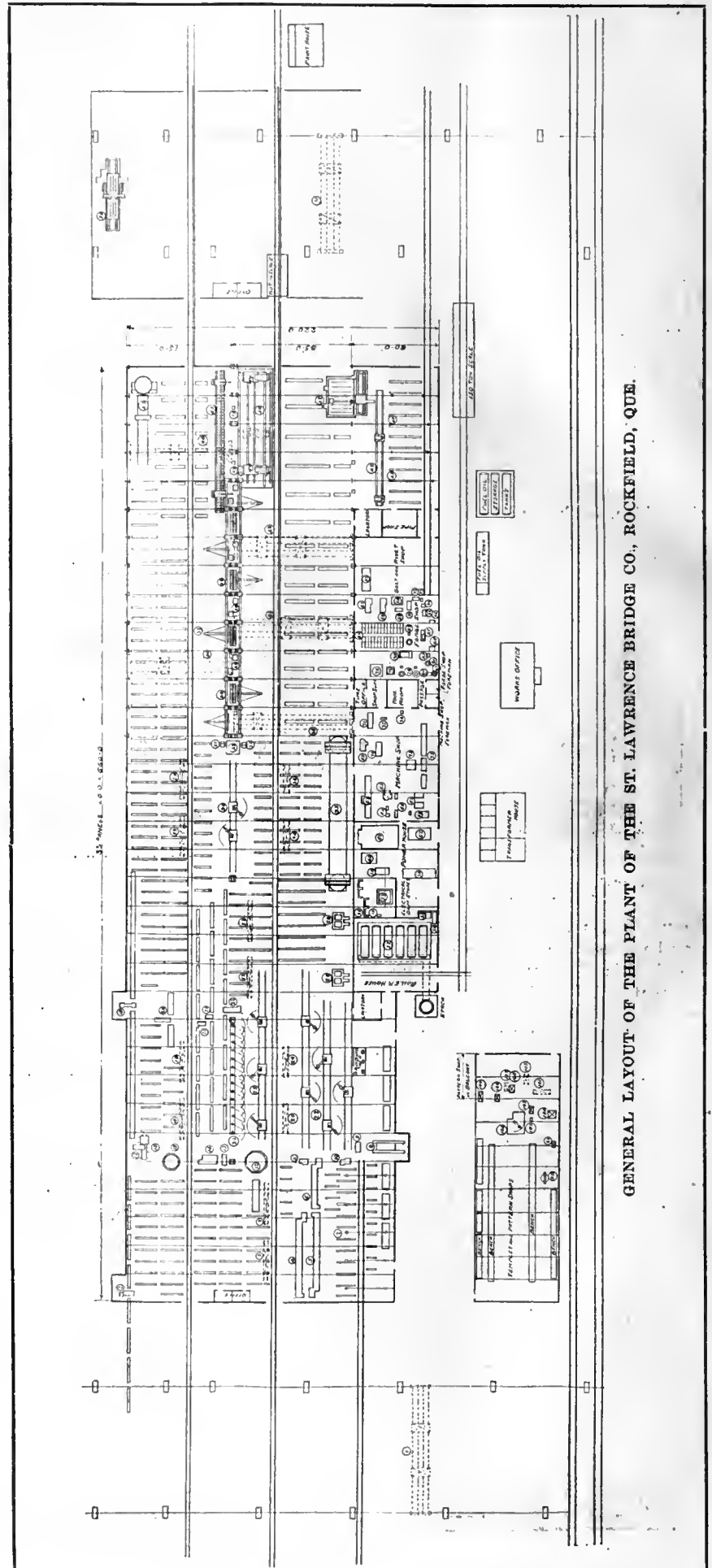

GENERAL LAYOUT OF THE PLANT OF THE ST. LAWRENCE BRIDGE CO., ROCKFIELD, QUE.

shop serve to carry finished members.

The 75-ft. bay is intended for members under 70 tons in weight and is equipped with two 35-ton cranes, duplex chord boring machine and riveting equipment. On the south side of this bay there is a 60-ft. lean-to, which is de-

signed by a double trolley 70-ton crane, the runway being 500 feet long by 80 feet wide. A part of this is covered in to form a paint shop, in which is located, for want of room elsewhere, a large 10 ft. x 10 ft. x 30 ft. surface planer. This machine will be used for surfacing the

heating purposes. In summer electrical energy is purchased from outside sources, and of course, is available at any time; so that all possibility of a break down is practically eliminated.

Steam is generated in six return tubular boilers, 72 in. diameter by 20 ft.

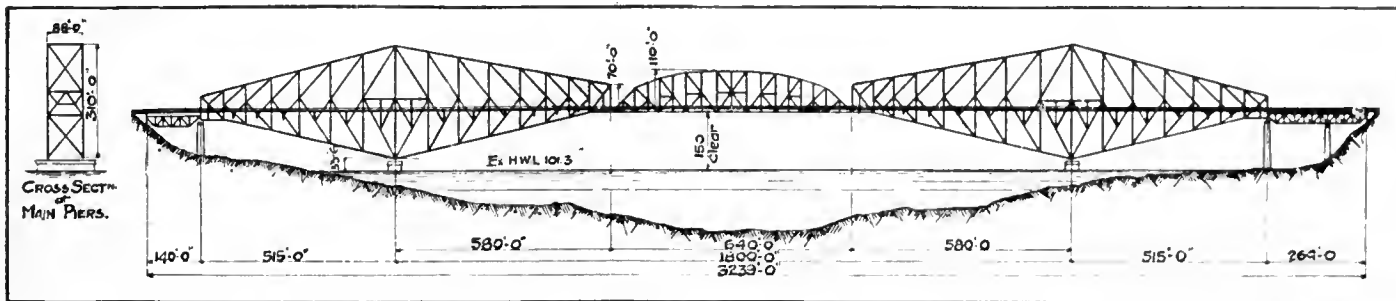

SOUTH END.

QUEBEC BRIDGE.

NORTH END.

voted to eye-bar boring and also contains the forging and rivet-making departments, machine shop and power house, which will be dealt with later.

The main building is of fire-proof construction with a very heavy steel frame, steel sash, concrete roof and steel skylight frames glazed with wired

large sections comprising the shoes of the bridge.

Finished members are weighed on a Fairbanks registering beam track scale of 150 tons capacity.

The Templet Shop is 60 feet by 176 feet, of brick and steel construction and has the usual equipment. A balcony at

long. These work at a pressure of 150 lbs. per square inch and are hand fired.

The engine room contains a Belliss & Morecom engine direct connected to a 400 K.W. direct current generator. Compressed air is supplied by a Rand horizontal cross compound steam-driven compressor with a capacity of 2,000

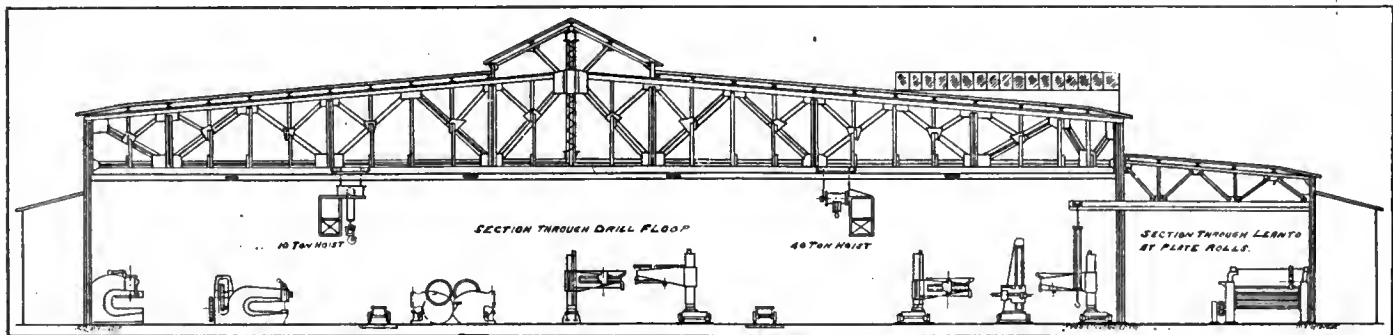

SECTIONS THROUGH DRILL FLOOR AND LEAN-TO AT PLATE ROLLS.

glass. The natural lighting is excellent in every part of the shop and a comfortable temperature is maintained in winter by a fan blast system which distributes air heated by exhaust steam.

The storage and loading of finished material is under a crane runway at the east end of the plant. This is served

one end accommodates a few pattern makers. The building is well heated and lighted and is conveniently located close to the main shop.

The Power House.

In winter the plant generates its own power, the exhaust steam being used for

cubic feet of free air per minute. The place of a fly wheel is taken by a 370 H.P. synchronous motor, which in summer will be used to drive the compressor, the pistons of the steam cylinders being then disconnected.

Preparations at the Site of the Bridge.
The St. Lawrence Bridge Co. are es-

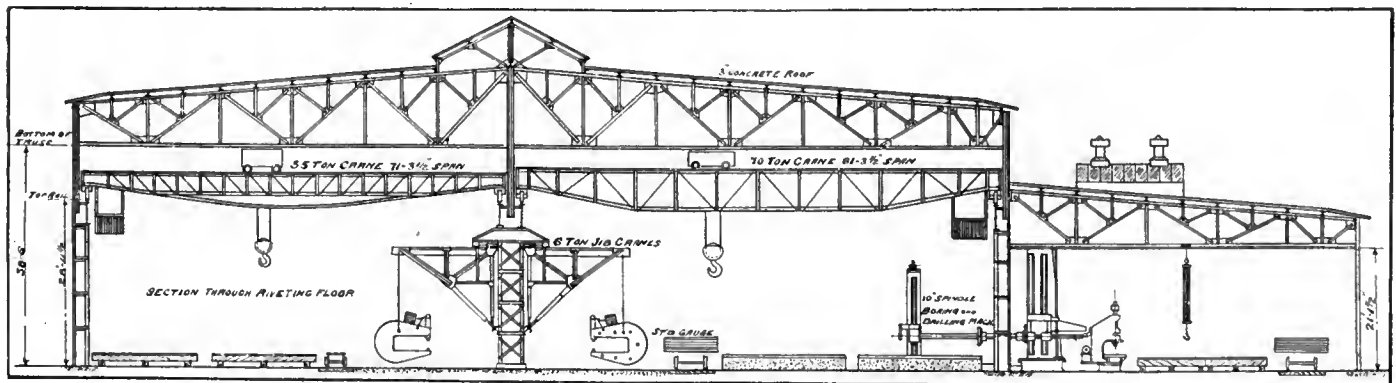

SECTION THROUGH RIVETING FLOOR, LOOKING EAST.

establishing an extensive and elaborate camp at the site of the bridge, on the north shore of the river. Its present capacity is for 300 men and every effort is being made to have things comfortable and up-to-date, with a view to keeping the men in good health and contented with their surroundings.

There will eventually be more than fifteen separate buildings of substantial frame construction, heated by steam and lighted by electricity supplied from transformer stations on the site. On the north shore current is received at 22,000 volts A.C., while on the south shore it is purchased from another company at 11,000 volts A.C. On each side of the river there will be two 250 K.W. motor generator sets delivering direct current at 250 volts. The two stations will be connected by a cable across the river

with hot and cold water laid on. Sixty men can be accommodated here at one time.

Every man in camp will sleep on a spring mattress provided with sheets and blankets,—a vast improvement over the bunking arrangements to be found in most camps. A 300-ft. artesian well has been sunk and provides all the water used. The water has been tested and found particularly pure.

The camp will be policed by a staff of special constables in the company's employ, and there will be a man whose sole

One of the most difficult problems of erection to be overcome will be the raising of the centre suspended span. This

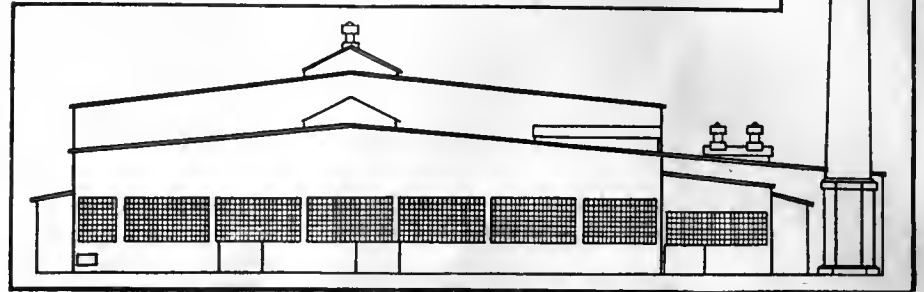

NORTHWEST ELEVATION OF MAIN SHOP.

duty it will be to see that the camp is kept in a clean and orderly state.

A regular sewage system has been installed and also hydrants for fire protec-

weighs about 3,000 tons. It will be assembled on shore, floated out on scows and then raised into position by jacks and blocking. This difficult operation will not be facilitated by the 8 or 9-mile current that runs at this spot during flood tides!

Machine Tool Equipment.

- 1—15-ton crane.
- 2—Small str. and bending machine.
- 3—10-ton assembling hoists.
- 4—45-ft. edge planer.
- 5—45-ft. edge planer.
- 6—20-ft. edge planer.
- 7—Air hoists.
- 8—Plate rolls.
- 9—Furnace.
- 10—18 inch Punch and shear
- 11—Angle milling Machine.
- 12—7-ft. plate shear.
- 13—36 inch punch.
- 14—36 inch single rotary planer.
- 15—Double head angle shear.
- 16—Spacer.
- 17—36 inch punch.
- 18—10-ton assembling hoists.
- 19—48 inch multiple punch.
- 20—60 inch punch.
- 21—16 3-4 inch punches.
- 22—Heavy bend and straightening machine.
- 23—10-ton assembling hoists.
- 24—Stationary drills.
- 25—Portable drills and tracks.
- 26—40-ton assembling hoists.
- 27—Portable drills and tracks.
- 28—Manhole boring machines.
- 29—10 ton assembling hoists.
- 30—Portable drills and tracks.
- 31—Grinder.

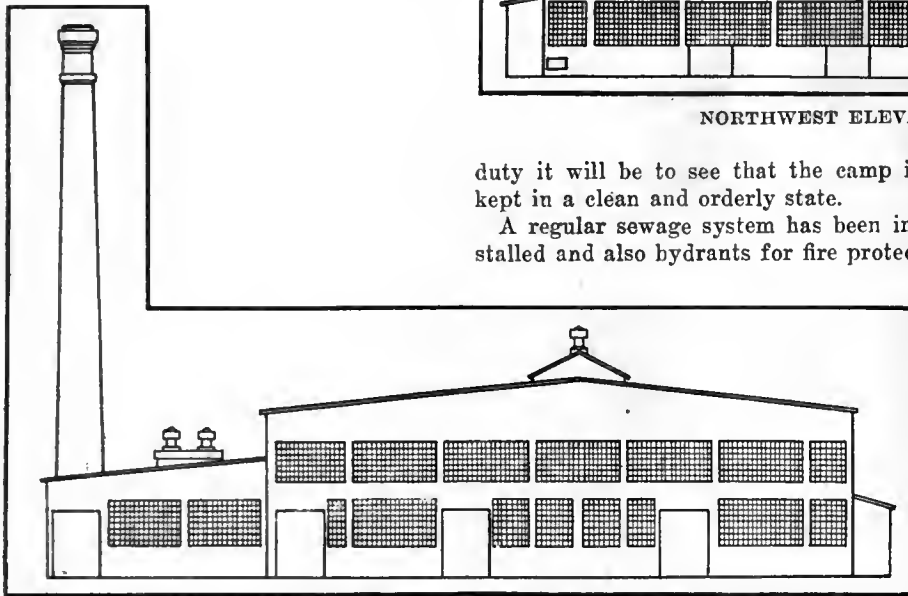

SOUTHEAST ELEVATION OF MAIN SHOP.

bed, to avoid any possibility of failure of the supply.

A special feature of the camp is a finely equipped dining room which will seat 300 men at once. The cooking facilities are as good as are found in most hotels.

There is a central wash house equipped with wash basins and shower baths,

tion purposes; a water tower supplying the pressure.

About 600 men will eventually be employed on the erection of the bridge, and to transport those working on the south cantilever to and from the camp, the company are building a gasoline launch capable of ferrying 100 men at each trip.

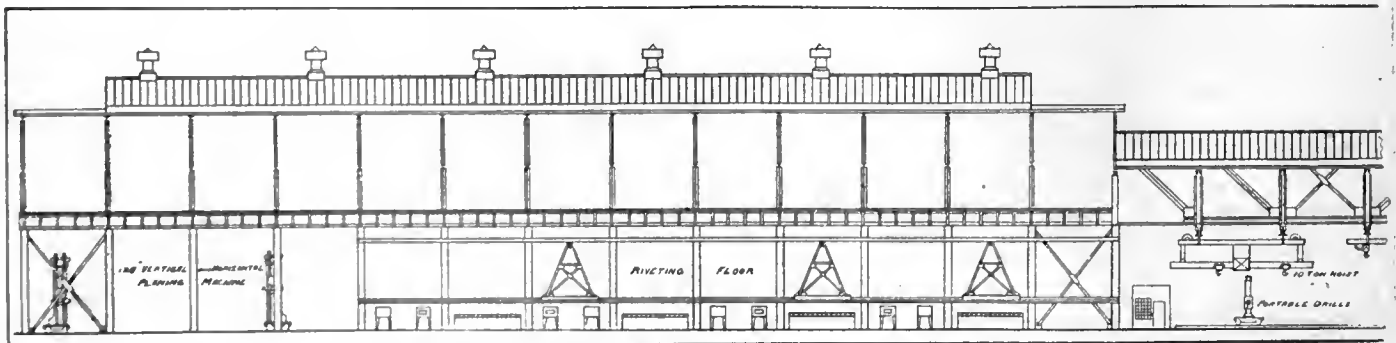

LONGITUDINAL SECTION THROUGH CENTRE OF SHOP.

STEEL PASSENGER CAR CONSTRUCTION.*

By H. H. Vaughan.**

THE advent of the steel passenger car has brought with it many new problems and an opportunity for more diverse opinions than any other change that has taken place in car equipment. The construction of the wooden passenger car developed along fairly uniform lines. The varieties of framing were few and the differences unimportant, while the introduction of steel platforms, wide and narrow vestibules, reinforced end and sill construction and similar improvements occurred gradually, and with practically similar designs on all railroads. The change from wood to steel in freight car construction resulted in the abandonment of designs that had almost standardized, and in the introduction of many new types, but in this case the principal problem, other than that of obtaining satisfactory designs, has been the extent to which it was advisable to use composite or all-steel construction.

Considerations to be Accounted.

In the case of the passenger car, the types to be employed will probably not be changed by the substitution of steel for wood. The increase in capacity that has taken place in freight equipment cannot be duplicated in passenger cars, and there appears to be no tendency at present toward any increase in length or carrying capacity. The questions that now confront us relate rather to the design and construction of cars of the present type and of the materials that may be advantageously employed in place of the wood which has been used for so long. They are complicated by the necessity of providing for greater safety for the passengers than was secured in the wooden car, with an equal degree of comfort and the difficulty of anticipating the behavior of this new equipment in the case of accident.

Certain difficulties such as the best

*From a recent discussion, American Society of Mechanical Engineers.
**Asst. to Vice-President, C.P.R., Montreal.

systems for heating, lighting and ventilation, are common to both steel and wood construction, and improvements in these matters pertain to general progress rather than the use of steel construction. The following list, while probably incomplete, outlines in a brief way the important variations that must be considered in deciding on the preferable construction of steel passenger equipment:

- Framing—Steel underframe; all-steel frame, centre girder, side girder.
- Outside finish—Plated, sheathed.
- Roof construction—Clearstory, circular.
- Inside finish—Steel, wood.
- End construction—Design and strength.
- Floor—Design and Material.
- Insulation—Material.

No doubt questions of equal importance have been omitted, and in many cases those mentioned require careful consideration with regard to degree, as, for instance, the strength of the framing or the thickness of the insulation. The list illustrates, however, the diversity of possible solutions of the preferable steel passenger car, and the following personal opinions are presented for the purpose of opening the discussion:

Personal Views.

The steel underframe does not appear to be a satisfactory or permanent development. There is but little saving either in weight or cost over the all-steel construction, and it is difficult to see how the same strength in case of accident can be obtained. Experience will show whether the wood superstructure can be secured in such a way as to prevent working as the car gets old, but as it cannot be arranged to carry any weight this appears questionable. It can hardly be regarded except as an intermediate step between all-wood and all-steel construction.

In all-steel construction, the side-girder car presents advantages, but as in freight construction, both types will probably persist. The side-girder construction obtains greater strength in the side framing without superfluous

- 32—Grinder.
- 33—Fitters office.
- 34—40-ton assembling bolsts.
- 35—60 inch duplex rotary planer.
- 36—35-ton crane.
- 37—6-ton jib cranes.
- 38—Rivet bins.
- 39—Furnaces.
- 40—35-ton crane.
- 41—70-ton crane.
- 42—70-ton crane.
- 43—60 inch single rotary planer.
- 44—35-ton crane.
- 45—Horizontal chord borers.
- 46—26 inch vertical and horizontal planing machine.
- 47—10 inch spindle, drilling and boring machine.
- 48—Eye bar boring machine.
- 49—Air Hoists.
- 50—120 inch surface planer.
- 51—70-ton crane.
- 52—Bollers.
- 53—Heater.
- 54—Pump.
- 55—Heating coils.
- 56—Trap.
- 57—Ventilating fan.
- 58—Fan engine.
- 59—Switchboard.
- 60—Motor generator set.
- 61—Air compressor.
- 62—Belliss engine and generator.
- 63—Planer.
- 64—Grinders.
- 65—Boring Mill.
- 66—Drills.
- 67—Shapers.
- 68—Grinder.
- 69—Radial drill.
- 70—Turret lathe.
- 71—Turret lathe.
- 72—Metal saw.
- 73—Milling machine.
- 74—Grinder.
- 75—Lathes.
- 76—Plate furnace.
- 77—Swage block.
- 78—Forge and anvil.
- 79—3 cwt. air hammer.
- 80—Furnaces.
- 81—Crucible.
- 82—Lead pot.
- 83—Forge and anvil.
- 84—Rivet bins.
- 85—125 lb. hammer.
- 86—Bolt cutter.
- 87—Cont. feed rivet machine.
- 88—Hand feed rivet machine.
- 89—Furnace.
- 90—Rivet rod furnace.
- 91—Bolt header.
- 92—Nut tapper.
- 93—Nut hurring machine.
- 94—Bolt pointer.
- 95—Triple bolt cutter.
- 96—Bar shear.
- 97—Cont. feed rivet furnace.
- 98—Portable wood trimmer.
- 99—Drill.
- 100—Tenoning machine.
- 101—Lathe.
- 102—Grindstone.
- 103—Band saw.
- 104—Radial drill and table.
- 105—Buzz planer and jointer.
- 106—Rip and cross cut saw.
- 107—Band saw.
- 108—Pony planer.
- 109—Buzz planer and jointer.

R. Hunter, assistant engineer at the Beach pumping station, Hamilton, Ont., has resigned. He was receiving \$1,050, and has secured a position at \$2,000 at Welland.

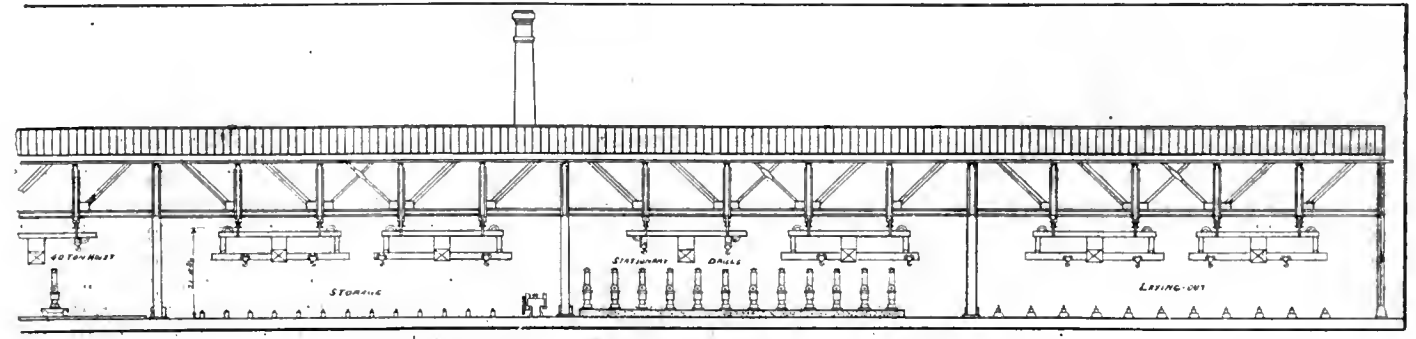

LONGITUDINAL SECTION THROUGH CENTRE OF SHOP.

weight, and it is possible that greater framing strength may prove necessary. With equal strength of side framing, the side-girder car may be made lighter than the centre-girder type, and the weight of steel passenger cars is one of the most serious problems to be faced by any railroad not having a level line. American passenger equipment was already excessively heavy per passenger carried with wood construction, and the use of steel has increased this weight from 10 per cent. to 20 per cent., which is a most serious matter. Apparently side-girder cars as so far constructed have a decided advantage over the centre-girder type in their light weight and greater strength in case of accident tending to crush in the side of the car. This will probably lead to the use of this type on roads on which weight is of importance.

In spite of the many advantages of the sheathed car in cases of construction and maintenance, it appears that the cost and weight of the additional metal will prevent its extensive use. This question is chiefly one of appearance and convenience, and is of minor importance.

Roof and Interior Finish.

The circular roof has been extensively introduced on steel passenger cars on account of its lightness and simplicity of construction. It has the objection that deck sash ventilation cannot be employed. The Pullman Company, while using the clearstorey roof, have, however, discontinued the use of deck sash ventilation, so that evidently in their opinion this objection is not important. The deck sash is, however, of value in a standing car, and when properly screened is certainly advisable in hot weather, especially when the road is dusty. The Canadian Pacific Railway have compromised on this question, and are using a roof of approximately circular form with deck sash. The strength and simplicity of the circular roof is retained with the ventilating qualities of the clearstorey type.

The preferable material for inside finish is a matter for future decision. With the ample protection afforded by a steel car against accident, there does not appear to be any objection to wood inside finish on the ground of safety. It is more ornamental than steel and a better insulator. Probably on no question in passenger car design is opinion so divided amongst both railroad and car-builders. There is to-day very little difference in cost, and it certainly appears probable that in the future the tendency will be to adopt steel interior finish if not entirely, at any rate to a great extent.

The construction of the ends of the

cars has received considerable attention, and the strength now usually employed is enormously greater than anything attempted in wood construction. Several excellent designs have been devised.

Floor and Insulation.

The floor construction in steel cars is entirely different from that in wooden cars, and is usually of metal covered with a flexible cement. In constructing a sample car for the Canadian Pacific Railway, the writer used in addition an underfloor covered with insulating material, and covered the cement with $\frac{1}{2}$ in. of cork. This car was also exceptionally well insulated at the sides, 2 in. of cork being used next the outside plating. Tests during the past winter have shown that this car is actually warmer than the ordinary wooden car, the same amount of heating surface being used in both types. The floor was tested by taking the temperature of water standing in cans on the floor, there being no practical difference between the results in the wood and steel cars. The question of insulation is an important one, both in hot and cold weather, and while other insulation might no doubt be equally effective, it is interesting to be able to advise that with proper insulation there is no question of the steel car being satisfactory.



LINING UP THE PLANER BED.

By J. K.

IN lining up the planer bed, particularly if it be a long one, it is almost impossible to ensure accuracy, by reason of the limitations in the tackle employed. The usual method consists in laying in the vees (if the bed is of the vee'd variety) cylindrical rods, placing on these straight edges, and then raising or lowering as the case may be the bed until it shows approximately level by a spirit level placed on the straight edge. This test is made in all directions, and is fairly reliable for comparatively short beds; but in the case of long beds, errors may arise through the lack of sensitiveness in the spirit level, through the impossibility there exists in reading the position of the bubble sufficiently accurately, and through the shortness of the spirit level as compared with the bed. Errors may also exist in the straight edge and cylindrical bars, and may be cumulative.

Hydrostatic Method.

It is not generally known that there is a method of lining up by which almost absolute accuracy may be attained, and for lack of a better term this will be called the hydrostatic method. It is applicable to other levelling processes, and is extremely simple in application.

In the case of the planer bed having inverted vees, the two vees are connected by pipes and stopped up at the ends by plates screwed on or fixed in any other convenient manner. These plates may have holes by which a pipe may be carried from one vee to the other. A fluid-tight joint must be made at the plates. The vees are now filled with some liquid; water will do, but paraffin is preferable, as it does not tend to formation of rust. An ordinary micrometer or the barrel portion of a micrometer (these are to be bought separately) is attached to a light angle-plate in such a way that the measuring end of the screw points downward. The angle-plate is preferably made from sheet steel, which will displace as little fluid as possible, and the micrometer must be located in such a manner that the screw may touch the surface of the liquid.

Operation.

The first operation consists in placing the angle plate in the vees at intervals, then screwing down the screw until it just touches the surface of the fluid. This should be done very carefully, the movement being, say, by half-thousandths of an inch. Just before contact is made, the fluid rushes up to meet the micrometer, and careful test has shown that this occurs always at the same position. The micrometer readings at various positions along the vees is registered, so as to enable the bed to be vertically adjusted by exact amounts. One point can, of course, be considered correct, the others being raised or depressed to correspond with it.

In order to ease the difficulty in raising or lowering the bed to secure levelness, the packing blocks should be of the vertically adjustable form, and, moreover, should be fitted with a screw adjustment of such a nature that the amount of the vertical adjustment can be controlled and known through the angle of rotation of the screw. The angular surfaces of the packing blocks might be, say, tapered one in ten, and the lead of the screw, which is used for the sliding motion, be made ten threads per inch, so that one turn of the screw results in a vertical adjustment of one-hundredth of an inch. The head of the screw, if divided into ten, would enable adjustments of one-thousandth of an inch, or even less, by reading between the lines to be readily made.

In the case of beds having a flat top, the writer suggests that an oil channel might be formed by bending and welding up a piece of square or rectangular iron or steel bar and making a point with some kind of plastic material, as putty, white lead, etc.—Page's Weekly.

Some Features of Modern Foundry Roof Construction

By Joseph Homer

The roof is a portion of a foundry building which, in the olden days at least, received little attention. Roof light was often not available at all, and roof ventilation was insufficient or wholly absent. Principals were usually of heavy timber, affording lodgments for dust. Leakages between slates or tiles, especially in snowy weather, damaged moulds, or rendered prompt migrations to more favored areas necessary.

THE ideal roof of the modern foundry building is one which admits enough light to the shop without absolute necessity for putting windows in walls. In saying this, we do not mean to convey the impression that windows so located should not be used. They are unnecessary, however, and from some points of view are undesirable, because they admit the glare of direct sunlight and cast shadows; they render shops

roof. In the ideal roof, the principals are of steel bars, which neither hold much dust, nor obscure light, nor catch fire. The selection of type is not very important. In England the ridge roof with a louvre is the predominant pattern, a variation on this being the ridge roof with louvre ventilation (termed a monitor roof on this continent), in which the glazing is on the north slope only. The louvre or monitor must,

sign divides favor with the monitor roof and with a ridge roof of extremely flat pitch.

In the ordinary ridge roof the skylights should be arranged continuously along each side—an uninterrupted length of glass extending throughout nearly the whole distance, and occupying roughly one-fifth or sixth of the width of each side. This is better than dividing the glazed portion up into little

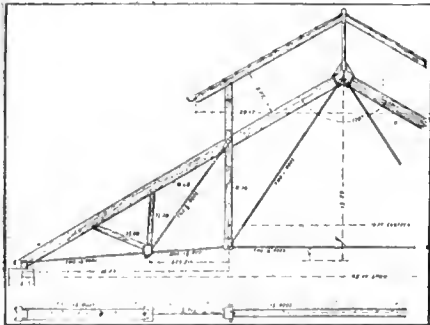

FIG. 1. A METHOD OF FRAMING TIMBER PRINCIPALS.

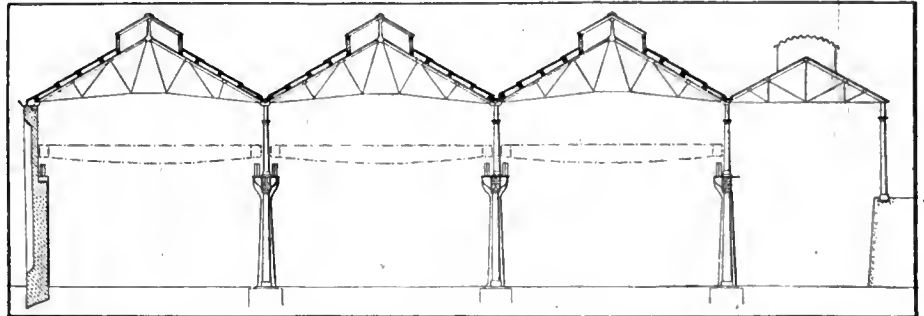

FIG. 2. SECTION THROUGH STEEL FOUNDRY, LANCASHIRE & YORKSHIRE RY., HORWICH.

cold in winter and hot in summer; they occupy space which might often be better utilized for hanging plated patterns and tackle; and they require frequent cleaning. For these reasons some foundries are either without them or have only small window areas in walls.

Roof Lighting.

Ample light is a cheap investment, and it can be obtained wholly from the

therefore, be high enough to protect the glass from the direct rays of the sun.

Latterly, the saw-tooth design has grown much in favor. This is based on the practice of the weaving sheds, and its advantage lies in the arrangement of all the glass on the steeper side which faces towards the north, so that although there is ample light, there is never any direct sunlight. Here this de-

areas—oases of light, separated by deserts of slates or tiles, which fulfil no useful object and increase risk of leakage.

In all modern foundry buildings, unless the space available is insufficient or of irregular or inconvenient shape, the bays and their roofs run parallel. It is always desirable, also, to arrange buildings with extra yard length at the end

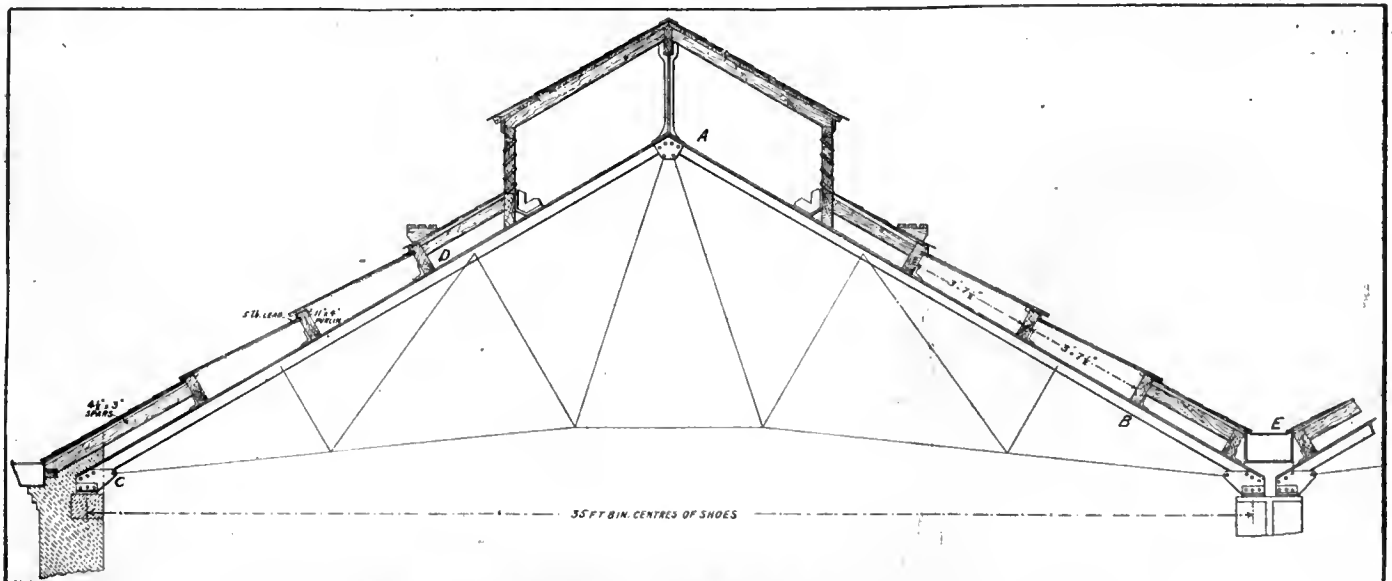

FIG. 3. ROOF FOR STEEL FOUNDRY, LANCASHIRE & YORKSHIRE RY., HORWICH.

for possible future extensions, should these be required. The extensions take the form of a repetition of parts of the existing roof and its supporting columns, so that a building 200 feet long, can be increased in length indefinitely.

Span Feature.

It is also desirable to have the spans as uniform in width as possible, and if not in width, then in pattern. A foundry where light, heavy, and moderately

longer spans than light ones, so that, while a light traveler will have a span of, say, 30 feet, a heavy one may be of 50 ft., 60 ft., or 70 ft. The additional span is necessary to permit of free movement of the heavier and larger work dealt with.

Roof Types.

The selection of roof types which illustrate this article is sufficient to emphasize the great diversity which exists in design. These are examples from

steel-framed roof is now held in greater favor.

Fig. 2 gives a transverse section through the iron and steel foundries of the Lancashire and Yorkshire Railway at Horwich, England. Fig. 3 is one single roof principal of Fig. 2 complete, of which Figs. 4, 5, 6 and 7 are enlarged details. Fig. 8 is a side elevation of a length of the shop, to show the roof lighting and the windows in the walls. The three bays of equal width, Fig. 2, and cover one area, which is unobstructed save by the columns which support the roofs. The lighter roof, to

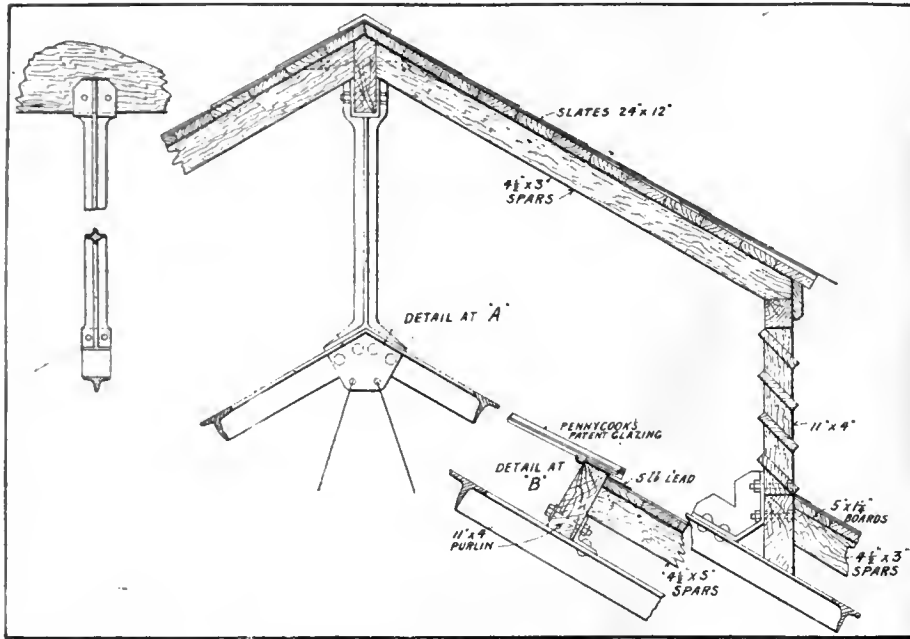

FIG. 4. DETAIL OF LOUVRE AT "A," FIG. 3. SMALL FIG. AT "B."

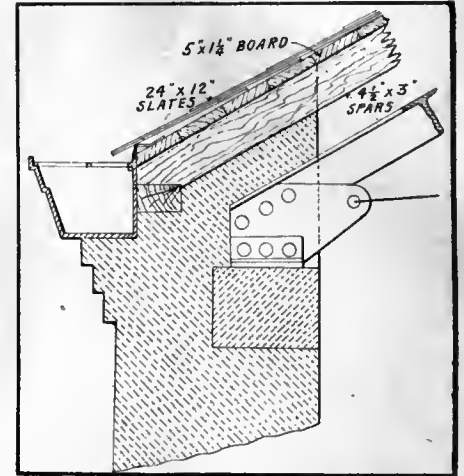

FIG. 5. DETAIL AT "C," FIG. 3.

heavy work is done need not, and should not, have its corresponding areas separated by walls. The roof-supporting columns only need indicate the divisions. If there is not much difference in the weight of work turned out, the roof principals should all be of equal span, but if some work is very heavy, and some very light, a difference in span is entailed by the differences in the power of the overhead traveling cranes required. Heavy cranes usually have

British foundries. An illustration of a timber roof principal only, of 45 ft. span, covering the bays of a foundry, is shown by Fig. 1. The timbers are of read deal, socketed into shoe castings. The ties are round rods of wrought iron arranged as indicated. The tie-beam seen in plan below is formed of various rods passing through holes bored in the shoes. There is no objection to the employment of such principals, notwithstanding that the light

the extreme right of Fig 2, covers the cupola room only, and, therefore, does not extend far longitudinally. The roof louvres and the continuous glazing are seen in the elevation, Fig. 8, and the columns which carry the roof sustain also the gantries for the overhead traveling cranes. The detail of the roof of one of the bays is given in the group of Figs. 3 to 7. It represents one of the side bays of Fig. 2. The middle bay, the commencement of which is seen to the right of Fig. 3, only differs from the side bays in having no terminating outer edges.

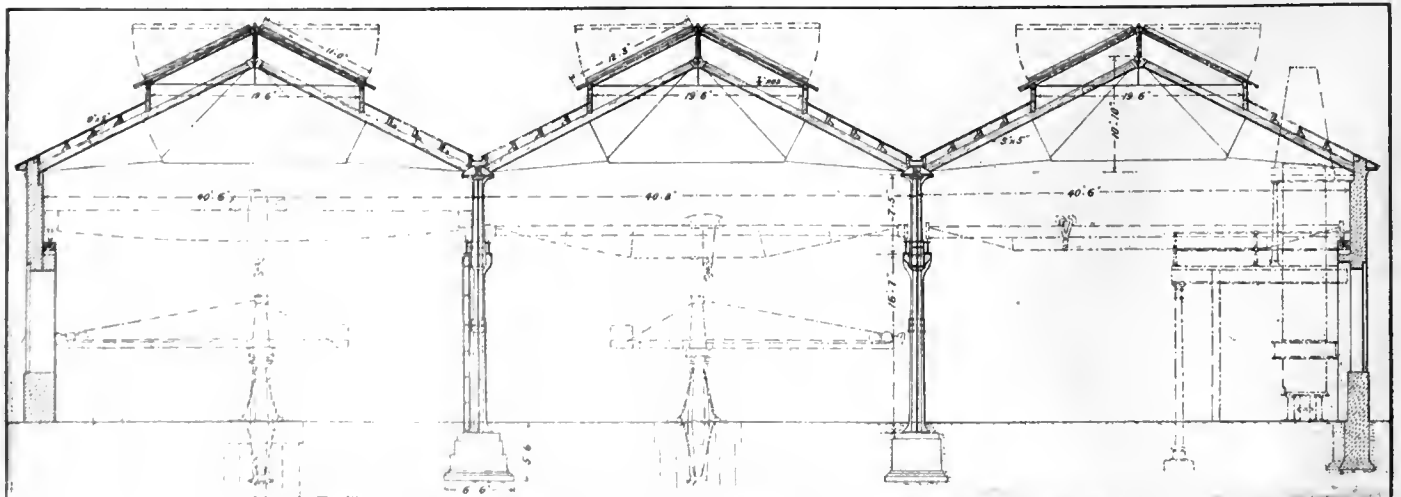

FIG. 9. ROOF OF IRON FOUNDRY, LOND ON & NORTH WESTERN RY. CREWELL

The principals are of T-section, spaced at 15 ft. centres, each forming with the tie-rods a self-contained truss. Timber purlins running longitudinally on the sections and secured with angle irons receive lead protectors to prevent entry of rain. The tiled portion of the roof is supported on timber spars, 4½ in. by 3 in., spaced at 2 ft. 6 in. centres, covered with narrow boards 5 in. wide by 1¼ in. thick, on which the slates, 24 in. by 12 in., are laid. The glazed portion occupies the middle space between the tiling. In this case there are two thicknesses, comprising a ¼ in. rough plate glass, covered with Pennycook's patent glazing.

The louvre over the ridge is shown in detail in Fig. 4, its ridge pole being car-

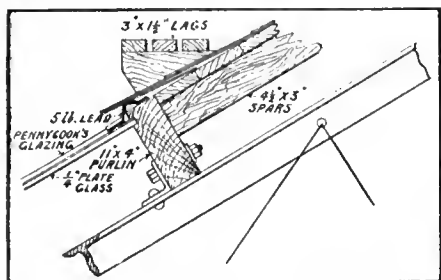

FIG. 6. DETAIL AT "D," FIG. 3.

ried on central castings. The diagonals are carried by the central cast iron ridge member at one end, and, at the other, on timber uprights measuring 11 in. by 4 in., secured to the roof principals by steel angles. They are spaced at 2 ft. 6 in. centres, and are traversed by narrow boards which carry the slates. The timber uprights receive the louvre boards, 1¼ in. thick. The connection between the slated and the glazed portion is seen in detail at (B) in Fig. 4.

The details of the abutment of the principals and the outside guttering are shown in Fig. 5, and those of the jointing of the glazing with the timber again in Fig. 6.

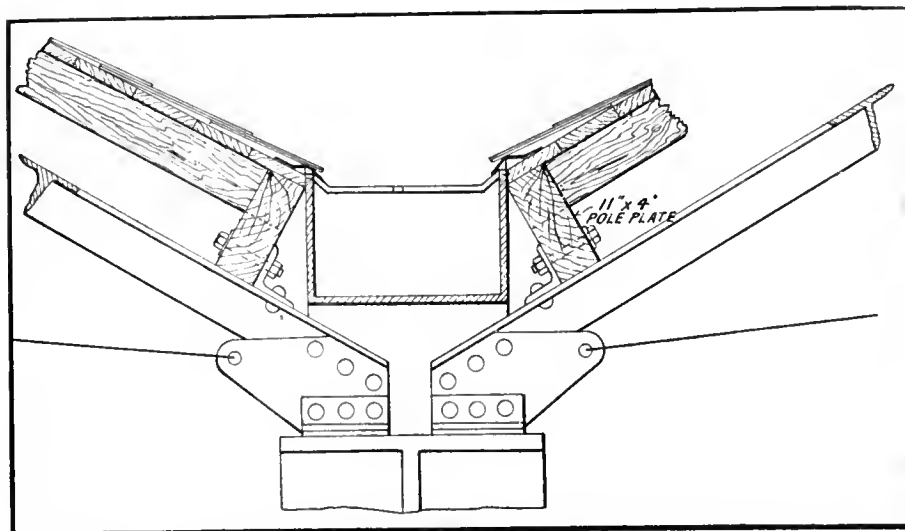

FIG. 7. DETAIL AT "E," FIG. 3.

Fig. 9 illustrates the roof of another English railway foundry, that of the London and North-Western, at Crewe. This is of timber. The supporting columns leave a broad unobstructed floor area, which is covered by electric

tooth roof. The right-hand slope carries glass only, the left, slates or timber only. The amount of slope varies greatly in different examples.

A favorite type of American roof is the monitor, one which somewhat re-

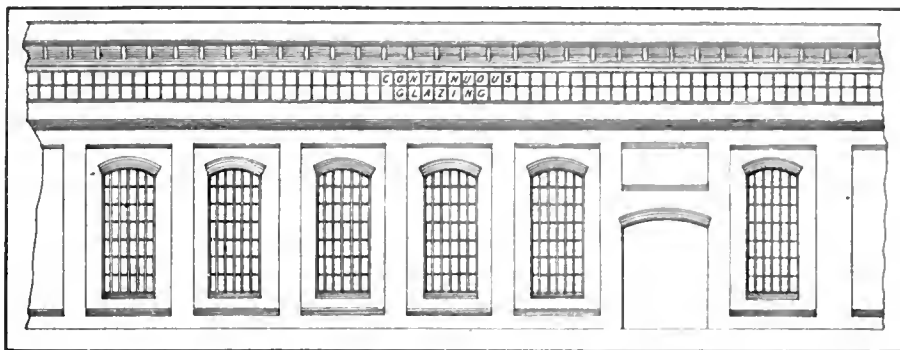

FIG. 8. ELEVATION OF STEEL FOUNDRY, LANCASHIRE & YORKSHIRE RAILWAY, HORWICH.

traveling cranes, there being independent hydraulic cranes to serve certain areas.

A frequent foundry design is that of a ridge roof covering a high main central bay, flanked by lean-to roofs covering the side bays. It is economical

sembles the louvre roof, but in which the place of the slats is occupied with continuous glazing, besides which this portion is very much wider than in the ordinary louvre roof. There is no roof light besides, but the walls are nearly "all windows."

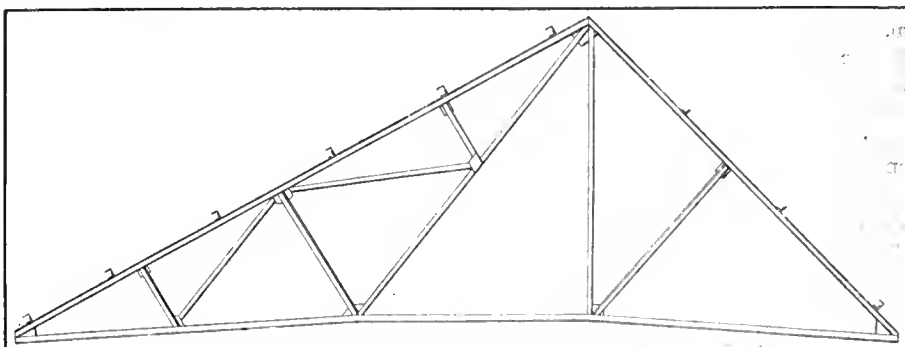

FIG. 11. PRINCIPAL OF SAW TOOTH ROOF.

in material. Fig. 10 is an outline sketch of such a roof over the steel foundries of the British Westinghouse Co., at Trafford Park.

Fig. 11 shows one principal for a saw-

Objections to Roof Lighting.

Objections to roof lighting are the risk of injury to men in consequence of fractured and falling glass, the difficulty of keeping the skylights watertight, and of cleaning windows. The risk of fracture has frequently been provided against by covering the glass with wire netting of fine mesh, which, however, interferes with cleaning. Leakage is avoided by using special jointing instead of putty. Risk of damage by fracture is absolutely prevented by casting woven wire in the middle of the glass, so that should the glass break the wire retains the pieces in place. This has been demonstrated again and again in fires where the glass, though traversed with many cracks, has held together.

Glass Feature.

The wired glass, Fig. 12, is either rough-cast, rolled or clear polished. The first is obtainable in thicknesses of

7-16 in. and $\frac{1}{2}$ in., the last two in $\frac{1}{4}$ in. thickness. Two thicknesses may be used—a rough-cast sheet within and a rolled sheet outside, as in Fig. 6. The light-giving effects of glass are increased by the use of a prismatic or saw-tooth section, Fig. 12, which faces within the building, and which gives a larger area for the refraction of the light. This "refrax" glass is made with and without inserted wire. The sheets are in large dimensions, the rolled to 36 in. wide and 120 in. long, and the cast to 80 in. long by about 28 in. wide. Pennycook's patent method of glazing avoids the use of putty, using lead instead, as seen in Figs. 3, 4 and 6. The

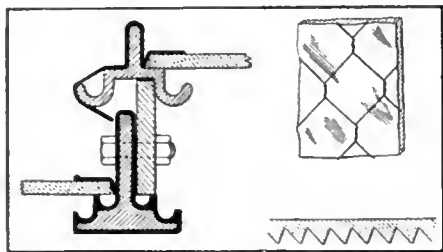

FIG. 12. SECTION THROUGH JOINTING OF SKYLIGHT WITH MAIN SASH FRAME. PENNYCOOK'S PATENT GLAZING.

FIG. 13. "REFRAX" WIRED GLASS.

lead confines the glass, and is shaped like a miniature guttering to retain any moisture which may condense within.

Fig. 13 shows a section through an opening skylight with an adjoining section of the main sash frame as used in this system. The gutters in the sash bars and the disposition of the lead prevent leakage-in of rain. The lead in the skylight sash is bent over to conduct the rain down the sides.

CANADIAN-RAND PRESENTATION.

An interesting gathering took place at the Canadian-Rand foundry, Sherbrooke, Que., on Saturday, May 10, when Mr. Chivers, on behalf of 100 em-

ployees, presented Mr. Smith foundry foreman, with a diamond ring and a pair of cuff links on the occasion of his departure to New York to assume a more responsible position in the company's service. An address accompanied the presentation.

Mr. Smith feelingly replied, thanking the men for their kindness, and assured them that he would always cherish very happy recollections of his association with them.

AMERICAN FOUNDRYMEN'S CONVENTION.

PREPARATIONS for the conventions of foundrymen at Chicago in the week of October 13 and for the associated exhibition under the direction of the Foundry and Machine Exhibition Co. have already taken such form as to promise an exceptional success for this annual gathering. The choice of Charles A. Plamondon, president A. Plamondon Mfg. Company, as chairman of the Chicago committee on arrangements and his acceptance are especially happy, because of Mr. Plamondon's connection with the formation of the Western Foundrymen's Association at Chicago in May, 1893, just 20 years ago. Mr. Plamondon was the first president of that organization.

The importance attached to the American Foundrymen's Association Convention and the Foundry Exhibition is evidenced by a movement to bring to Chicago at the same time the meeting of the National Founders' Association, held annually at New York City in November, and also by a proposal to inaugurate the holding of fall meetings by the National Metal Trades Association on the same occasion.

It is reported regarding the exhibition to be held at the International Am-

phitheatre beginning Friday, Oct. 10, that within one month following the preliminary notice regarding the exhibit space applications were received exceeding the entire amount used at Buffalo in 1912. By the first week in March, six months before the date of the exhibition, reservations made by 45 firms which had a total of 18,656 sq. ft. in 1912, aggregated 23,859 sq. ft., an increase of 33 1-3 per cent. The interest displayed by builders of machine tools this year is especially noteworthy, and assurance is given that at least 25 machine tool builders will be represented by motion display and other exhibits.

FACTORY INSPECTORS IN CONVENTION.

THE annual convention of the International Association of Factory Inspectors convened in Chicago on May 6, at the Hotel Sherman, where many rooms had been transformed into model factories by the installation of modern machinery, with every possible safeguard to life, used in various lines of manufacture. In other rooms were displayed machinery used in the same lines of manufacture, but without the safety precautions. These exhibits were used to illustrate the most prominent question under discussion during the three days' session, namely: How can accidents to operatives be prevented?

Another question discussed was that of occupational disease. Many prominent physicians were in attendance and gave their views on this subject.

Prominent among the delegates and guests at the convention were Samuel Gompers, president of the American Federation of Labor; Fred C. Schiedtam, of St. Louis, president of the National Manufacturers' Association; John Mitchell, formerly president of the United Mine Workers of America; Gov. Edward F. Dunne, of Illinois; Mary Drier and Henry Morgenthau, of New York City; John J. Whalen, of Albany, N.Y., and Perry F. Powers, of Lansing, Mich.

A. Wischam, of the Illinois Department of Factory Inspection, had charge of the local arrangements for the convention, including the exhibits in the Hotel Sherman.

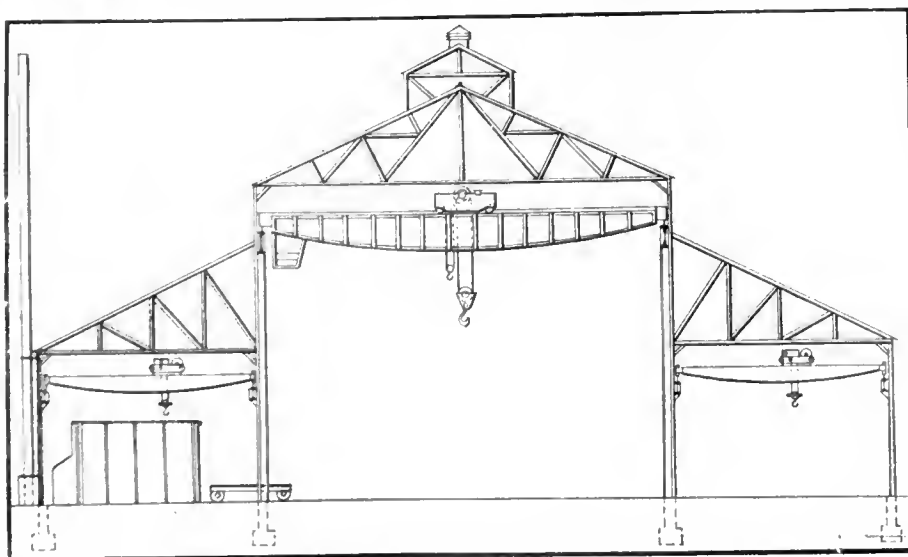

FIG. 10. RIDGE ROOF FLANKED BY LEAN-TO ROOFS.

Sherbrooke, Que.—The committee, composed of Mayor Herbert, Ald. Thompson and Ald. Jencks, have been appointed to negotiate with a syndicate for a site, on which they propose to build a car wheel foundry, employing one hundred men. The new plant will cost \$50,000.

Observations on Modern Methods of Artificial Lighting*

By Albert L. Pearson**

Lighting of our workshops and factories continues to exercise the expert mind and gives scope for the application of ideas there formulated—One of the reasons contributing to this condition is due to the fact that most every plant or department therewith connected, has to be individually heated.

THIS paper is not intended to go into details, but simply to call attention to some of the underlying principles, and as electric light has become the standard illuminant, it is the only one which will be considered.

There the two principal forms of electric lamps—are and incandescent. Several types of each are as follows:

Arc.	Incandescent.
Open carbon.	Carbon.
Enclosed carbon.	Tantalum.
Intensified carbon	Tungsten.
Flame.	
Mercury.	
Luminous or Magnetite.	

Systems of Arc Lighting.

There are a great many systems of arc lighting in use to-day, and some of them are quite satisfactory. The open carbon arc used with high voltage constant direct current generators has been displaced generally by the enclosed carbon arc operated in multiple on low voltage direct or alternating current circuits. The intensified carbon arc is doubtless the best of this series, and due to its design, the principal objections to the other types of arcs are practically overcome—that is, the "traveling" of the arc around the crater causing varying shadows, and the change in position of the arc relative to reflectors, thus interfering with the working of any well planned scheme.

Flame arcs are not generally used indoors except in foundries and machine shops, with very high roofs or similar places. The light is very penetrating, thus making the lamp an excellent one for smoky places.

The mercury arc is finding a place in machine shops and textile plants, and is meeting with great favor in the silk industry. The principal objection to this lamp is the color of the light—a cold green. It possesses, however, two distinct advantages—great diffusion of the light, due in a large measure to the fact that it emanates from a line rather than a point, and the line distinction or clearness with which threads or lines may be distinguished. I believe it has been proven that this light does not produce injurious effects upon the eye.

The following statement is taken from a report on tests made by C. H.

Williams, M.D., and Dr. Louis Bell upon a number of persons who have worked in the light of this lamp:

"In comparing all the cases examined, the fact which stands out most distinctly is that in no case does a careful ophthalmoscopic examination show signs of trouble with the optic nerve or retina, which cannot be more properly attributed to other causes. In no case was pathological change found in the crystalline lens or the transparent media of the eye, not even where there have been years of work under the most trying conditions possible, and where the men were day after day facing the glare of scores of lighted mercury-vapor tubes on the racks of the testing room. Immediately after leaving work under the mercury lamp, color fatigue was clearly observable, as was to be expected. The fatigue is merely temporary, and was least noticeable in some of those who had worked longest under the light, as if the eye had acquired a certain degree of immunity to the unusual stimulus."

A fluorescent reflector is being developed, which is intended to supply the missing red rays to a certain extent, and thus make the light more natural. A new form of this lamp is also being developed.

The luminous, or magnetite arc, is not used indoors. This is replacing carbon arcs for street lighting, and is used only on constant direct current systems.

Incandescent Lamps.

Of the incandescent class, the Tungsten lamp is the most efficient, 1.25 watts per candle power, as against 3.6 watts for the carbon lamp. The Tantalum lamp falls about midway between these two for efficiency; 2.0 watts per candle power. In its present high state of development the Tungsten lamp is practically free from early defects, and works equally well on alternating or direct current, while the Tantalum lamp gives best service on direct current. Alternating current produces the effect of repeated blows and the filament breaks in a short time, higher frequencies having worse effect than low. This lamp, therefore, should not be used on alternating systems.

In addition to its efficiency, the quality of light from the Tungsten lamp is superior to that of other illuminants of

this class, most nearly approaching the ideal. This lamp is the greatest competitor of the mercury arc, or Cooper-Hewitt lamp, is being adopted as the standard of best practice for incandescent systems.

Fundamental Principles.

It is only during the past few years that attention and careful study have been given to the proper arrangement of lighting systems, and there are a number of fundamental principles which should always be followed out in making a lay-out.

As the operative is the one for whom the light is provided, he should be given every consideration.

Lamps hung low down which can be adjusted by the operative should be avoided wherever possible. Not only is he liable to experiment with the lamp and waste time, but may interfere with the work of other operatives.

Lamps should be arranged to give uniform illumination at the working plane, avoiding shadows as far as possible; particular attention should be given to the requirements of each machine.

White walls and ceilings are advantageous and add to the effectiveness of the lighting systems. With individual driving of machines, it is possible to keep the rooms cleaner than with mechanical or group driving, thus benefiting the lighting system.

On account of the glare low exposed units should be avoided. In places where it is necessary to have the lamps low down, reflectors which will entirely conceal the filaments should be used. In such cases, it is usually necessary to provide lamps close to the ceiling for lighting shafting, etc., and to overcome the effect of light and darkness.

The position of lamps should be carefully determined, both as to spacing and mounting height. In general, the height of the lamp above the floor should be such that with the spacing available, the lines representing the angles of maximum illumination with a given type of reflector will cross at the working plane.

Each problem must be considered by itself. A system of illumination which works out well in one case may be anything but what is best suited for another.

*Abstract of a paper read before the A.S.M.E. at the Boston Engineer's Club.

**Electrical Engineer, Lockwood, Greene & Co., Boston.

Points in Favor of Good Lighting.

There are a number of points in favor of good lighting.

(1)—Safety; (2)—Better sanitary conditions; (3)—Better quality of work and increased production.

In places where very good light is not required, or where it is used for comparatively short periods of time, it obviously does not pay to invest as much for this part of the equipment as in places where it is required for long periods or is depended upon for quality of work.

Lighting systems cannot be worked out as formerly—so many watts or candle power per square foot—but a study must be made of conditions so as to produce a layout which will prove economical and bring forth results.

Distributing Systems.

The distributing systems should be carefully worked out in order to secure good voltage regulation. Circuits and switching should be arranged with respect to different processes in such a way as to eliminate the use of power for lighting in sections not in use. On low frequency alternating current systems, small incandescent lamps should be avoided as much as possible on account of flicker. The latter is more troublesome with higher efficiency lamps.

DRIVING BELTS.

DRIVING belts, states a contemporary, often undergo improper treatment. If they fail in their work by slipping over the pulley without driving it, resin is usually resorted to, and while certainly a good help for the time being, it is sure to spoil the belt, making it rough and brittle. In a dusty room, an emery-like mixture is formed by the dust and the resin, which rubs away the belt. Moreover, the adhesion preparations, sold to prevent belt slip, are not always to be recommended, and often contain harmful acids. Care must be taken to avoid putting an unreasonable overload on the shafting, and to see that the pulleys are properly arranged in respect to diameter and distance apart.

In the case of a new wet-stretched belt, it is advisable to make a careful examination of its structure, especially in respect to flaws, etc. The outer surface should then be thoroughly greased with a mixture of melted tallow and train oil, which should be rubbed in so that it saturates the leather. This imparts, first of all, lasting elasticity and a very high degree of durability, and afterwards keeps the belt pulley in good condition, as the grease permeating the leather is carried over it, leaving a coating which is of such a nature as to en-

sure almost perfect adhesion to the pulley. When this coating has vanished, which will ordinarily happen in three to four months, the greasing of the belt should be repeated, after it has been well rubbed beforehand with sand paper.

Where the temperature is comparatively high, this fresh treatment becomes necessary more frequently. The use of resin or any strong adhesive substance should be resorted to only in exceptional circumstances.

BLAST FURNACE AT PORT COLBORNE, ONT.

WORK is well under way on the blast furnace which the Canadian Furnace Co. is building at Port Colborne, Ont. The company is controlled by the Buffalo Union Furnace Co., Buffalo. It is expected that the furnace will be in operation late in July or early in August. It will produce the Victoria brand of pig iron in foundry, malleable and Bessemer grades, and will have a capacity of 300 to 350 tons a day. It is the intention to instal a pig-casting machine in connection with the manufacture of basic iron for the Canadian trade. At the start the iron will be handled by a Brown pig breaker.

The furnace is 80 ft. x 19 ft. 6 in., and is equipped with three two-pass stoves, 85 x 20 ft. The boiler equipment consists of 2,400 h.p. Wickes boilers, and the blast will be furnished by high and low pressure Allis-Chalmers vertical long crosshead engines of 84 in. diameter of blowing tub by 60-in. stroke. Electric power will be furnished by two 300-k.w. General Electric turbines. Two 6-ton McMyler ore bridges will be operated on an adjoining dock of 600 ft. frontage on the Welland Canal, in which there is 23 ft. depth of water. It is the intention to add another stove and a high-pressure blowing engine at an early date. The product of the furnace will be sold by M. A. Hanna & Co., Cleveland.

CLEANING GAUGE GLASSES.

CLOSE the upper and lower valves and open the pet cock to empty the gauge glass of water. Hold a cup or other suitable receptacle containing muriatic acid of ordinary strength under the pet cock. Open the lower valve sufficiently to cause the acid to be drawn to the top of the glass. The alternate opening of the lower and upper valve causes the acid to be drawn up and repelled. Two or three applications will clean a dirty glass thoroughly.—Exchange.

WOOD PRESERVATION.

A NEW method of wood preservation has been used in Hungary with the aim of meeting the requirements of impregnating the inner layers of the poles without wasting too much of the impregnating fluid. The process uses some of the creosoting oil on the section above ground and a greater quantity on the rest of the pole. All that is required for preservation is to inject enough of the creosote into the pole to kill off any fungi germs that might try to enter or have entered from the outside. For this purpose the pole is perforated at the lower end for a distance of about 10ft., so that the creosote can penetrate deeper into the pole than would be possible otherwise. A special machine is used to drive sharp and strong needles of about 1 in. length into the poles. Through this treatment, the wood fibre and texture is not torn apart, but the wood is merely opened to admit the creosote oil deeper into the pores.

NEW BRUNSWICK ORE.

THE 52nd annual report of the Crown Land Department of the Province of New Brunswick, covering the year ending October 31, 1912, shows that the Canada Iron Corporation, Ltd., has added to its iron mining plant, at a cost of \$600,000, a large concentrator with a capacity of 700 tons per day of 10 hours, and that in the summer of 1912 about 30,500 tons of ore were treated in this mill. Only 5,000 tons of ore were mined, which, with 60,000 or more left over from the previous year, was shipped to Philadelphia. A contract for the delivery of 200,000 tons for the current year has been made.

ELECTRIC FURNACES IN ENGLAND.

ANOTHER 10-ton Héroult electric furnace was started recently by Vickers, Ltd., at their works at Sheffield, England. It is said to be capable of melting and refining 40 tons of cold scrap per day. This firm has now been producing electric steel for two years. England, as the Iron and Coal Trades Review shows, is not keeping pace with Germany or the United States in the increase in the number of electric furnaces. Germany is continually applying this process to the refining of basic Bessemer steel, and the United States to the manufacture of small castings. Germany has one plant where Héroult furnaces of 28-ton capacity are thus employed and several others of 6 or 7 tons. Tube steel in Italy has been manufactured for several years in furnaces of 6 to 7-ton capacity, and it has been recently decided to erect two more of 15 tons capacity for the same pur-

A Pension Plan for Employees in the Machinery Trades*

By William Lodge**

The author of this paper makes abundantly clear his conviction that provision made for a firm's employees is conducive to high degree loyal service. The various considerations to be accounted in the establishment of a pension plan are worthy the earnest attention of both parties to the scheme—master and servant.

IN my opinion, the establishing of a life pension for such of our employees as have filled all the conditions to be set forth is of vastly more importance to our working people as a whole than is the question of workmen's compensation. It is also of more importance to our members in general, as it will help to solve some of our problems regarding the keeping of good men in our employ. Those of us who do business know the restless and floating tendency of men, and the advantage of being able to keep the same set of men whom we have educated with great care and often at considerable cost. This is such a real advantage that it will pay us to adopt any reasonable plan which will secure such results. It would also tend to steady the population in our industrial centres.

Many cases may be cited where pension plans are working out successfully, imparting a comfortable feeling to the minds of the men, and, when they know that to leave their employers means the abandonment of that pension, any change is apt to be considered very seriously. In such a case, the matter would not always be decided by the men alone, as wives and children are likely to add their influence towards having the man remain in a steady position; in fact the benefits to both parties seem almost incalculable, and any reasonable plan should have our very careful consideration.

Pension System Basis.

Any pension system should be based upon some plan that will pay the beneficiary not less than one-half the usual wage. The Government pension to common soldiers and sailors is open to many criticisms on this account. The establishment of a pension system necessitates the setting aside of a fund that will form a nucleus and finally the capital on which the pensions may be based. If, for instance, a concern employing only 100 men should decide to set apart two cents per hour for every operator in its employ, this would mean approximately \$6,000 per annum on the basis of a 10-hour day. If any concern using the premium plan would put aside a like amount per hour out of the

hours saved, it would double this fund, which would soon reach the point of sustaining any pension payments that need be made. With the growing tendency toward some system of award to be paid the men, in addition to their daily rate, a portion of the savings might be placed in the fund, which would grow more rapidly than might be imagined.

Change of Conditions.

Any employer who has maintained an efficient system of knowing the cost of manufacturing realizes the tremendous change in the art of machine making which has taken place in the last 10 years. The decreased cost of production has been largely due to the advent of high speed steel and the designing of machine tools which could use that to the best advantage. This has been hastened by the advent of the automobile, as the demand for these has made possible the development of special machinery and the lowering of cost of production. As an example, take the four-throw crank of an automobile. A comparatively few years ago this required 10 hours' time to machine the pins, while with the new and special machinery, they can be turned ready for grinding in 15 minutes each.

Many other cases might be cited, but I wish to point out that, owing to the improved methods which have so materially reduced costs, we are in a position to lay aside a small portion of this saving over former costs as a basis for the pension fund. In other words, we should adopt some system that will permit the taking of a portion of the profits which have come through the adoption of more modern systems of doing business, whether these savings come from the machine shop, from the method of buying material, from the maintaining of prices against unfair competition, or in any of the many ways which are proving economical in modern business.

Sources of Savings.

I might enumerate a few of these, such as a little closer attention to designing and to the drawings as they go into the shop; the establishing of a routing department where none is in use; the economical handling of incoming and outgoing materials; a careful tabulation of results from different de-

partments; a good system of inspection; and a clear understanding of the methods adopted by the Metal Trades Association in the handling of labor problems. An astonishing amount of saving may often be made in this way, by preventing time and money losses, also hard feelings caused by avoidable strikes. In many cases, the amount saved in a single instance of this kind would make a very respectable foundation for a pension fund.

These are only a few of the many things to be considered, my main object being to call your attention to the desirability of making a start so that a fund may be accumulated from which pensions may eventually be paid. In case any member may decide to adopt such a plan, there are a few points connected with it which it may be well to bear in mind.

The Retiring Age.

My suggestion would be 65 years. But this should not be arbitrarily fixed. It should be at the discretion of the trustees handling the pension fund, as there may be cases where it is desirable to extend the limit and others where a man should be retired before reaching this age. The Pennsylvania Railroad pension plan allows retirements earlier, but not later than the age limit fixed.

Period of Service.

This should probably be at least 25 years before a man becomes eligible to receive the pension, but might also be left to the discretion of the trustees.

The Pension Fund.

This should not be handled by the firm or company, but by a board of trustees. Such an arrangement is on the advice of an eminent lawyer, because of its being an obligation on the firm or company if so handled.

Apprentices.

The need of a retiring age is clearly shown, as an apprentice entering the shop at 15 would be only 40 at the end of 25 years' service.

Number of Pensioners.

By going over your books you can readily see how many employees have been with you 25 years. This will give you a line on the possible number of pensioners and form a basis for the probable demand on the pension fund in

*Presented at the annual convention of the National Metal Trades Association, New York, April 10.

**President Lodge & Shipley Machine Tool Company, Cincinnati, Ohio.

the next 50 years. It must be remembered, however, that a larger percentage of employees will serve the required number of years with a pension plan in existence.

Adding to the Pension Fund.

There should be a thorough threshing out of all methods of adding to the pension fund, and these should be decided upon and put in writing, with a request for suggestions from the various people interested. The question as to who should contribute to the fund should be carefully considered. My own idea is that this should be established entirely by the firm and that the men should have no part in its maintenance.

Amount of Pension.

This varies widely. Some large corporations, including railroads, both in this country and abroad pay two per cent. of the average wage earned during the 10 years preceding retirement. Others pay one per cent. for every year of service, based on the preceding 10 years as above. This is hardly sufficient, as it necessitates a man's serving fifty years to secure half pay.

Special Retirement.

This should be provided for in cases where the man has become incapacitated through ill-health before his 25 years of service has elapsed. A certificate from a physician approved by the trustees should be required in such cases.

Other Considerations.

Other cases to be considered are:

The continuance of the pension to the family after the death of the beneficiary.

Whether the fund shall be invested in municipal, State, national or railroad bonds, or otherwise.

Whether the beneficiary may engage in business on his own account after retirement, if said business would not be objectionable to the trustees.

Investing the trustees with power to suspend the pension in case of gross misconduct. Should a clause of this kind be adopted, it should be very carefully worded, so that it would be impossible for any trustee to debar a man on account of any personal differences, political or otherwise. Failure to do this is sure to be construed by the men as a club which may be used to infringe personal liberty and is sure to be resented.

Ample provision to prevent any beneficiary having a sum set aside for his own pension.

A discussion as to the plan of operation of the work, in which the co-operation of the employees may be had, such as the adoption of straight piecework, premium plan, or a combination of premium and bonus plans; but, regardless of the plan adopted, some portion of it

should be used for the establishment of a pension fund.

The possible discontinuance of the business either through death, ill health, lack of profit, or in any other way, and the disposition to be made of the pension fund in such cases. This is a question which must receive careful attention and on which your speaker will be very glad to receive the suggestions of the membership.

It should be thoroughly understood that the successful carrying out of such a plan rests with the employers alone. The whole subject is presented as a business proposition and not as a philanthropy in any way. Any company having a reliable pension system will be better able to retain its men for long periods of time. It will, I am sure, be a marked step in the advance of human progress, if pension systems can be made more general.

The general adoption of some such system, taking care to point out its advantages to the men, will lessen the restlessness and decrease the floating population, will retain the men we have taken the pains to educate, will increase the value of the business itself, and cannot help but tend to make better citizens.

835 NEW COMPANIES.

THE Department of State figures for the last fiscal year show a remarkable increase in the aggregate capital of the companies incorporated. There were 835 of these during 1912-13, with a total capitalization of \$625,212,199, while supplementary letters patent to 53 existing concerns increased their capitalization by \$55,249,900. There were only five decreases of capital authorized.

The total number of charters of all kinds issued was 938 and the total capitalization \$680,462,199. This is an increase over the previous year of \$189,896,200.

PORT COLBORNE BUILDING BOOM.

"ITS on the boom surely," said J. J. Pickman, Industrial Commissioner of Port Colborne, Ont., who visited Montreal last week. He was there on the hunt for building contractors. Think of that! Contractors! Mr. Pickman said that Port Colborne needs at once over three hundred new dwelling houses, and a number of Montreal contractors are figuring on the work. Behind his overture, the commissioner has the backing of the Union Furnace Co., of Buffalo, who promise him that they will lease the houses for a period of ten years and return fifty per cent. on the investment. Some idea may be gathered of the situation at Port Colborne when Mr. Pick-

man states that over 200 employees are now living under canvas and it is impossible to rent a house, apartment or room in the town. This mushroom-like growth of Port Colborne was occasioned by the Dominion Government having decided to spend \$50,000,000 on the improvement of the Welland Canal at the Lake Erie entrance, just where Port Colborne is located.

Mr. Pickman stated that natural gas sold in Port Colborne at 27 cents per thousand feet and can be tapped almost anywhere, while the nearness to Niagara makes the hydro power easy and cheap as well. The Buffalo Union Furnace Co. is bringing 400 men, he said, on Aug. 1. These, with their families, will make a marked increase in population, so that houses, and houses again, will be the slogan.

PROTECTION OF EMIGRANTS SEEKING EMPLOYMENT.

HIS Excellency the Administrator in Council, under the authority of Section 66 of the Immigration Act of Canada, is pleased to make the following Regulations for the protection of immigrants seeking employment from companies, firms, or persons carrying on the business of intelligence offices, or employment or labor agencies in Canada, and the same are hereby made and established accordingly:—

1.—Every person, firm or company engaged in the business of an intelligence office, or employment or labor agency, and having business dealings with immigrants, shall first obtain a license for this purpose from the Superintendent of Immigration, Ottawa, which license shall be issued without fee upon the Superintendent being satisfied that the applicant is duly complying with the requirements of the Immigration Act and orders in council or regulations passed thereunder; the license, unless otherwise cancelled, shall remain in force for the calendar year during which it is issued, and shall be posted in a conspicuous place on the holder's premises.

2.—Such license shall not be transferable, and shall be revocable on the written order of the Superintendent of Immigration, where the latter had been satisfied that the holder is not complying with the requirements of the Immigration Act, or of any orders in council or regulations passed thereunder.

3.—The Superintendent of Immigration shall keep a register of all license holders hereunder.

4.—No person, firm or company engaged in an intelligence office, or employment or labor agency business shall by advertisement, letter, poster, verbal communication or otherwise make false

representations to any immigrant seeking employment as to opportunities, or conditions of employment, with any employer in Canada.

5.—Every holder of a license under these regulations shall in books provided for that purpose keep the following records of his business, viz., the full name and address in Canada, and home address, if any elsewhere, of every immigrant with whom the holder has dealings; the port and date of the immigrant's arrival in Canada; the name of the steamship or railway by which the immigrant has come to Canada; the name and address of the immigrant's next of kin; together with the name and address of the employer for whom the immigrant is engaged; the nature of the work to be performed; the rate of wages to be paid, the rate of board, all deductions from wages, and other terms of engagement.



PIG IRON FROM INDIA.

CONSIDERABLE interest has been aroused in the steel trade by the news that a sailing vessel laden with about 2,500 tons of pig iron, shipped by the Tata Iron & Steel Company, of Sinaï, India, is now on the high seas bound for the Pacific Coast. The iron is consigned to one of the mills along the coast. Several shipments of Chinese pig iron have been made to this country within the past few years, but this is the first shipment from India reported.



TIDAL WATERS AS A SOURCE OF POWER.

AT a meeting of the Society of Engineers, Incorporated, held on Monday, May 5th, a paper on "Tidal Waters as a Source of Power," was read by Mr. C. A. Battiscombe, the object of the paper being to draw attention generally to the commercial possibilities of hydro-electric installations, more particularly with regard to the use of the tides. After some introductory remarks in reference to tidal intervals and the range of neap tides, the author points out that in this connection the head of water available for actuating turbines cannot exceed one-third of the range of minimum tides. The form of installation required for a continuous output of power is then discussed, the chief objections to twin installations, so placed that the tidal interval at the one will not synchronise with the tidal interval at the other, being pointed out. An outline is given of the arrangements proposed for the constant maintenance of a working head, by means of a chamber for the turbines, connected by valves to the tidal way and to three reservoirs in which the

tidal water may be impounded; and to this is added a description of the proposal of sequence of flow between the tidal way and the reservoirs.

It is claimed that the utilization of the tides for power purposes presents few engineering difficulties as far as principles are concerned, but that the real difficulty lies in the question of cost, and therefore in the choice of the site and in the design of the structural details.

The expenditure on commercial works that an engineer is justified in recommending is suggested, and some explanatory remarks are offered in respect to various items given in the rough estimate and to the principles governing the economical capacity of a proposed installation for any range of tide. The rough estimate follows next and the cost of the Board of Trade unit, obtained from the proposed installation, is considered from the point of view of supply and demand, both from a commercial and a municipal standpoint, on the basis of annual expenditure over a period of fifty years.

The paper concludes by insisting on the importance of regarding the supply of fuel as a matter that concerns the whole nation; that the demand for combustible fuel is continually increasing, and that coal being practically the principal fuel, it would be mere folly to neglect any other available source of energy whereby the present rate of consumption of coal may be sensibly reduced. It is submitted that not only can the tides be utilized as a constant source of power, but that, taken in conjunction with the power that could be derived from fresh water rivers, their utilization would be a great gain to the commercial and industrial interests.



ECONOMY HINTS FOR POWER USERS.

By F. R. Parsons.

THERE are many economies permissible in the power house which, insignificant individually, are worth considerable attention in the aggregate.

A pulley with a face burnished smooth as glass and polished like silver denotes slip. The discrepancy in the speed may not be proclaimed by a creaking belt, but it is there; a continual waste. The pulley may be undersized for the work or the belt slack or too frail, or its face glazed and dry, or a bad type of fastener is in use—any one of which may cause the trouble.

Inconvenience may be caused by the heating of a line-shaft bearing, which has cut badly, necessitating the removal of the top cap to re-channel the oil ways, and perhaps letting the top brass down a trifle to compensate for bottom

wear. If so, the shafting may have dropped a little at this point and need aligning and a little packing. Neglect of this creates a point of unnecessary friction and is a source of direct loss.

Packing Gland Leaks.

One of the most fruitful sources of waste, where steam is the motive power, is at packed glands. When compelled by very shame to do something to subside the hissing, the attendant may screw up the gland as tight as it will go. If that affords but temporary relief he removes perhaps the first ring, or two of packing and replaces with new. The old at the back of the box is too troublesome to remove, so it remains there, providing unnecessary friction and hastening the day, when a new rod will be required. The engine room attendant should be afforded a practical demonstration of how to pack a gland, the principles involved, and the advantages of using the kinds of packing best suited to the various requirements.

Generally a packing box is filled with ordinary fibrous packing, with or without a cushion core, and the gland nuts set up to ensure a steam-tight joint. As there can be no possible running adjustment with such a packing, sufficient pressure must be exerted on it and against the rod the whole of the time, to prevent leakage against the maximum pressure. As this maximum is only exerted momentarily during a fraction of the stroke, it follows that the pressure on the rod during the remainder of the stroke is excessive, and unnecessary power is expended by the engine in overcoming friction which should not exist. This represents wasted coal, reduces the life of the packing and unduly wears the rod, and can be avoided by selecting a packing which will automatically adjust itself to the varying conditions.

A perfect packing will only exert the pressure limit on the rod when needed at the moment the maximum pressure is upon it, as in the case of an engine at the point when the stroke commences. Directly the point of cut-off is reached, the pressure on the cylinder drops, and the pressure on the rod due to the packing should decrease in a like ratio. The packing most likely to fulfil these requirements in practice automatically expands and tightens itself against the rod under the varying pressures in the cylinder. Its steam-tight properties in the stuffing box are not, as in the fibrous type, governed by the pressure put on by the gland nuts, but is controlled by the direct action of the pressure in the cylinder acting on the automatically adjusting sections.

A series of tests taken on a 100 h.p. engine running at 235 r.p.m., with a

piston speed of 733 feet per minute, in order to determine the relative values of packings, proved that it took 33 1-3 per cent. more power to drive the engine with ordinary fibrous packing which had become hard and charred, and required considerably more pressure on the gland nuts to keep the joint steam-tight, than to drive the engine at the same speed with the glands filled with packing of an improved type with the gland nuts but very slightly over finger-tight.

Oil and Lubricants.

Amongst other economies is that of oil and other lubricants. Over anxiety to keep a troublesome bearing cool often results in going to the other extreme, viz., flooding. It is an old saying and true that a spoonful of oil at the right moment saves a gallon at the wrong. And this, if divided into drops, is worth far more than the whole dose given at once.

Then, what is done with waste oil? Does it run through the bearings and on to the floor? Oil, unless burnt, has lost none of its lubricating qualities in passing through a bearing. Oil filters are cheap, convenient, automatic in use, and will save their initial cost in a few months. The dirtiest of oil will come through them clear and fresh as when first drawn from the cask, and with none of its lubricating qualities impaired. On installing one of these, have all your bearings provided with suitable drip tins to catch the superfluous oil; also make provision on your engines for draining away all that has dripped from beds and splasher plates. Thick and black oil will clarify in the filter, but first let it settle in a vessel for a few days before putting into the filter, so that as much of the impurities as possible may fall to the bottom.

Economy in Belting.

Economy in belting is practiced by preserving as far as possible the natural state of the leather. When new it is pliable because of the natural oils contained therein; but when these become absorbed through atmospheric conditions or prolonged working, the material becomes brittle, surface cracks develop and the end of the belt is in sight; especially in belts working under abnormal conditions, such as over boilers, exposed to weather, chemical or acid fumes, or when anything of an abrasive nature is always present in the air. Under any conditions, belting requires a periodical dressing of a nourishing nature. If leather, a good dressing of equal parts of neats-foot and cod oil, mixed and applied with a stiff brush, is as good as anything; if cotton or canvas, crude castor oil will keep a belt in good working order and reduce to a minimum all tendency to slip.

There is a double economy effected in taking care of belts, as they not only wear better and longer, but a well-preserved, pliable belt will transmit more power than a dry, neglected one.

The Boiler Room.

I have indicated a few points as they occurred to me; but there are others—perhaps scores—which will catch an observant eye. Yet some men will never notice the boiler attendant sweeping away coal with the clinkers, firing the boiler or adjusting the feed water irregularly, or not appreciating to the full the proper use of the dampers, with the result that a dozen times a day golden sovereigns are being blown through the safety valve. If the armature brushes on the dynamo are sparking, there is another source of waste: not only the brushes are burning down and will soon require renewing, but the commutator is being unduly worn.

The eye of a trained man notices these things and he demands an alteration. Attention to these details means, in the aggregate, a lot to a power user when his profit and loss account is made up at the end of the year.—Machine Tool Engineer.



PORT NELSON.

FOLLOWING the decision of the Hon. Frank Cochrane, Canadian Minister of Railways and Canals, that Port Nelson, on the south-westerly shore of Hudson's Bay, near York Roads, is to be the tidewater terminus of the Hudson Bay Railway, work upon the \$25,000,000 project will be resumed this spring, so soon as the ice and snow have passed. The railway is designed to bring the vast grain areas of the Canadian North-West within a hauling distance of Liverpool of 3,500 miles, or about 1,800 miles less than the existing rail-and-lake routes through the ports of Montreal, St. John, N.B., and New York. Of the total length of 410 miles from Le Pas, a Canadian Northern Railway station on the Manitoba-Saskatchewan border, to Port Nelson, 75 miles already have been laid with track-
age and a bridge spanning the Saskatchewan River is all but completed.

Objection to Panama Route.

An objection to the Panama route for grain shipments exported through Prince Rupert and Vancouver is cited by J. B. Hunter, Deputy-Minister of Public Works, in the annual report of that Ministry, who avers that "in the warm, humid climate (of Panama) there is danger of grain heating." It therefore becomes apparent that the Hudson Bay route will enter sharply

into competition with the Panama Canal. In an article in the May issue of the National Waterways Magazine, by the National Rivers and Harbors Congress, Harry Chapin Plummer pays a tribute to the foresight and courage of the present administration of the Dominion in advancing to a state of early realization the magnificent undertaking, which he likens to "some epic stroke of daring by heroes of Norse or Nibelung mythology."

The writer observes that, unlike railways operating in more temperate latitudes the Hudson Bay Railway can be worked to its capacity for only two months in the year, and to a lessening extent for little more than another month, but that during this interval, the volume and importance of its dependable traffic dictate that it be literally overworked.

He quotes the chief engineer of the Hudson Bay Railway, John Armstrong, as pointing to the markedly increased difficulty a hostile fleet would have in attempting to blockade the Atlantic coast of Canada when the Hudson's Bay route is opened, due to the fact that ships can enter and leave Port Nelson all the year round.

"The likelihood of Port Nelson becoming an objective strategic point in the calculations of land or naval forces invading the Dominion occurs as not altogether a supposition," he observes, "when the picturesquely dramatic events of the long period of warfare between the English and the French, which was terminated by the Treaty of Utrecht, in 1713, are reviewed. The old Fort Nelson or Fort Bourbon as it was alternately called by its British and Gallic besiegers, became the scene of repeated conflicts, and the stubbornness of the resistance offered on each occasion of attack, and the decisiveness which marked its fall, proves how important a stronghold it was regarded."

Optimistic View of the Scheme.

An optimistic view is taken as to the probable effect of the development of the railway and steamship route upon the Hudson's Bay country, and the mineral wealth of the region is pointed to as promising the future exploitation of marble, iron, mica and limestone, especially in the territories known, until recently, as Ungava and the North-West Territory, but now included within the provinces of Quebec and Saskatchewan, respectively.

"A glance at the geological formation of the cliffs on both sides of Hudson Strait and the rocky highlands suffices to promise that, as the waterway comes to be frequented as a route of navigation, mining and quarrying industries will result in extending the

zone of operations of tramp steamers in the North Atlantic trade to the Strait proper.

"Bedded iron ore, similar to the iron-bearing rocks of Lake Superior, and credited as being of the same age as those famous deposits, have been the subject of investigation and analysis by corporate interests of the Dominion for several years past all along the eastern shore of Hudson's Bay, and marble of an exceedingly high grade is quarried on Marble Island, off the western shore of the bay on the mainland, near Fort Churchill.

"It is in the well-nigh inexhaustible motive power provided by the streams and waterways that the country to be crossed by the railway has its fundamental asset for future industrial exploitation. An approximate estimate of the discharge of the Nelson River alone gives indication of 156,869 cubic feet per second."



Toronto, Ont.—Thos. Kettle, a steel worker employed by the Toronto Structural Steel Co., was given judgment for \$800 damages against James Dempster by Chief Justice Falconbridge in the non-jury Assize Court, recently. Kettle was working on the construction of a building in Dufferin Street last July, when a steel girder fell on him and injured his leg. The accident was caused by the collision of one of Dempster's bread wagons with the truck on which the girder was resting, Kettle sued for \$1,500.

Montreal, Que.—To prevent the ratification of a contract between the Corporation of the village of St. Rose and the Standard Construction Company is the object of a petition presented to Mr. Justice Guerin, recently by Honore Ouimet, a ratepayer of the municipality. The corporation obtained power to expend \$70,000 on the construction of an aqueduct, and \$45,000 on the construction of sewers, and awarded a contract to the Standard Construction Co., who are named as mis-en-cause in the suit, to the amount of \$90,000. Mr. Ouimet now claims that the portion of the work to be executed by the Standard Co. is less than half of the total for which the expenditure was authorized, and that the remaining \$25,000 would not be sufficient to carry out the balance of the work. He therefore asks that the courts declare the transaction inconsistent with the powers and privileges of the municipality.

Sherbrooke, Que.—In the case of Demers vs. Goold, Shapley & Minn Co. the plaintiff bought from the defendant company a 12 h.p. engine for his moving picture outfit at Roxton Falls, for which he paid \$150 in cash and different notes to be paid at later dates. This was at the beginning of May, 1912. The engine was delivered at the end of the month, and during the course of the month of June he began to make complaints to the company that the engine did not develop enough power, and there were other defects, such as looseness of the piston attachment, the heating of the exhaust pipe, etc. The company's expert came to the spot, but no better results came from it. Hence the action to set aside the contract, to recover the cash and notes and for \$350 damages. The defendant company pleaded that it was too late for an action, and that the engine had not and was not tendered back. The court decided against the company on all points, and commanded it to repay the plaintiff the sum of \$232.50 as damages, as well as to refund the notes and the sum of \$150, and ordered the company to take back its engine.

EXPORT OF CANADIAN ENGINEERING PRODUCTS.

AS will be noted from the following details, a considerable trade is being developed in the export of Canadian engineering products to the Commonwealth of Australia:

Corundum Wheels.

A steadily increasing business is being transacted in the Australian market by Canadian makers of corundum wheels and the line is giving complete satisfaction to users. The shipments are promptly made and the goods are carefully packed.

Wrought Iron Tubing.

Probably the trade returns for 1912 will show that the Australian importations of butt-welded tubing doubled over the previous year. The tubing is giving every satisfaction and importers state the Canadian line is equal in quality to the best American.

Nail Wire and Wire Gauze.

Canadian nail wire has been in demand at regular intervals, but manufacturers, owing to the domestic demand, have frequently been unable to quote for export business, although small shipments have arrived in Australia in recent months. Prices being equal, Australian nail makers prefer Canadian to United States wire. For some time a fair quantity of wire gauze (fly wire) 12 mesh came to Australia from Canada, but recently no business has been done owing to United States quotations being lower.

Wringers.

The importation of Canadian wringers into Australia is steadily growing, and the 1912 figures show considerable expansion. Despite strong opposition from other sources of supply, the "made-in-Canada" line is gradually being introduced and is meeting with the approval of importers and users. The slowness in which orders from Australia are executed has caused justifiable complaints from importers who found their season half over before the goods arrived.

Lawn Mowers.

Comparatively small trade is being done by Canadian manufacturers of lawn mowers with Australia, whereas the exports from the United States show considerable increase. It is claimed that the Canadian mowers are too heavy in construction, and the patterns are not quite suitable for the Australian trade, which is well catered for by American makers. A large market awaits the Canadian mower made along the right lines at a competitive price. Possibly some manufacturer may specialize in this particular line, and will make an effort, through direct selling agents, to obtain a portion of this large trade. Orders from one Melbourne firm show that in 1912 over 500 lawn mowers were imported, this being by no means an exceptional example of the trade being done.

MASTER MECHANICS MEET.

THE C.P.R. railway master mechanics from all over the system east and west have been in semi-annual session at Winnipeg, at the local offices of the company. Matters were discussed including all conditions appertaining to motive power and rolling stock. Mr. H. H. Vaughan, assistant to the vice-president, at Montreal, attended the meeting, and others present included Messrs. Temple, superintendent of motive power, Winnipeg; H. Osborne, assistant superintendent of motive power, Montreal; C. Kyle, general master mechanic, eastern lines, Montreal, etc.

Plessisville, Que.—On Saturday, May 17, fire destroyed the plant of the Plessisville Foundry Co., at Plessisville, Que., entailing a loss of \$150,000. Great excitement reigned in this little place, and the whole village was on hand to help fight the flames. Everything, however, was lost, including patterns, matrices, drawings, moulds and cores. Eighty-seven men were employed in the foundry. It was announced by the directors that the premises would be rebuilt at once.

The MacLean Publishing Company

LIMITED

(ESTABLISHED 1888.)

JOHN BAYNE MACLEAN - - - - - President
H. T. HUNTER - - - - - General Manager

PUBLISHERS OF

CANADIAN MACHINERY AND MANUFACTURING NEWS

A weekly newspaper devoted to machinery and manufacturing interests, mechanical and electrical trades, the foundry, technical progress, construction and improvement.

H. V. TYRRELL - - - - - Business Manager
PETER BAIN, M.E. - - - - - Editor.

OFFICES:

CANADA
Montreal, Rooms 701-702 Eastern Townships Bank Bldg.
Toronto, 143-149 University Ave., Phone Main 7324
Winnipeg, 34 Royal Bank Bldg., Phone Garry 2313
Vancouver, H. Hodgson, 2640 Third Ave. West.

GREAT BRITAIN
London, 88 Fleet Street, E.C. Phone Central 12960
E. J. Dodd

UNITED STATES
New York, R. B. Huestis, 115 Broadway, New York, N. Y., Phone 2209 Rector
Chicago, A. H. Byrne Room 607, Marquette Bldg. 140 S. Dearborn St., Chicago

CABLE ADDRESS:
Macpubco, Toronto. Atabek, London, Eng.

SUBSCRIPTION RATE:

Canada, \$2.00; United States, \$2.50; Great Britain, Australia and other colonies, 8s. 6d. per year; other countries, \$3.00. Advertising rates on request.

Subscribers who are not receiving their paper regularly will confer a favor on us by letting us know. We should be notified at once of any change in address, giving both old and new.

Vol. IX. MAY 22, 1913 No. 18

PRINCIPAL CONTENTS.

Plant of the St. Lawrence Bridge Co., Ltd., Rockfield, Que.	533-537
Steel Passenger Car Construction	537-538
Lining-up the Planer Bed	538
Some Features of Modern Foundry Roof Construction	539-542
General	542
Canadian Rand Presentation...American Foundrymen's Convention....Factory Inspectors' Convention.	
Observations on Modern Methods of Artificial Lighting	543-544
General	544
Driving Belts...Blast Furnace at Port Colborne, Ont.	
Cleaning Gauge Glasses...Wood Preservation...New Brunswick Ore...Electric Furnaces in England.	
A Pension Plan for Employees in the Machinery Trade	545-546
General	546-549
835 New Companies...Port Colborne Building Boom...Protection of Emigrants Seeking Employment...Pig Iron from India...Tidal Waters as a Source of Power...Economy Hints for Power Users...Port Nelson.	
Recent Judicial Decisions	549
Export of Canadian Engineering Products	549
Master Mechanics Meet	549
Editorial	550
Industrial and Construction News	551-554
The General Market Conditions and Tendencies	555
Selected Market Quotations	556-557

COMPRESSED AIR IN THE FOUNDRY.

COMPRESSED air and electricity are two factors in the development and achievement of the foundry as we find it to-day, and each fills, as it were, a distinct place as the motive power for the operation of the machinery equipment installed. Electricity, it must however be admitted, is the motive power applied to the larger and heavier tools and appliances, and on this account should not be overlooked in its proportional contributory effect towards the recent rapid progress which the foundry has

made, and which has brought it into line with the kindred and dependent trades, at least so far as the newer and larger plants are concerned.

Compressed air on the other hand, has done much both for the foundry and foundryman, and in the latter feature, perhaps more than electricity. When account is taken of the miscellaneous assortment of light tools and appliances for the cleaning of castings, of the operation of ramming and moulding machines, and of the utility and dependability of the air hoist, we are inclined to think that the pneumatic feature has been most prominent.

Whatever tends to reduce physical exertion, while at the same time keeping or adding to a previous standard of achievement, produces on the mind and habit of the operator a higher sense of dignity, and who shall say that the foundryman of to-day is not the indisputable evidence of this new order of things? Machinery of any kind is after all an auxiliary to the personal element, through which it derives direction, and by which it is controlled. Compressed air by its very convenience and simplicity of adaptation to the purposes of the operator, has increased the quantity of output, improved the quality, has lightened the foundryman's labor and aided the cultivation of a higher degree of intelligence. Previous to the introduction of manual labor saving devices, bodily effort was necessarily supreme and all-absorbing, therefore, the mental was kept in the background undeveloped. The machine, however, replaces the physical effort, and gives scope for the co-operation of the brain, eye and hand.

Foundrymen appreciate the new conditions under which work is now performed, and in the matter of what has contributed most largely to their improved status, a consensus of opinion favors compressed air.

MUNICIPAL FOUNDRIES.

A REPORT comes from Calgary, Alberta, that on account of the high price of castings required for municipal purposes, a proposition is on foot to establish a municipal foundry. This is certainly a development we had not anticipated, even in this progressive Dominion of Canada, but, after all, in matters relating to civic government, there is nothing impossible of projection. It might also be added in the same breath, that there is seldom successful fulfilment.

We have not the facts concerning the prices charged, neither have we definite data concerning the local conditions, but it is safe guessing that the foundrymen of Alberta, and more particularly the city of Calgary, in that province, are not in any sense daylight robbers. There is a foundryman's side to the conditions from which has arisen this raw proposal, and when the facts become known, civic government in the persons of those responsible will have again made itself ridiculous.

There is no need to speculate on the possibility of the civic foundry project ever having being, for it is quite apparent that its sponsors are entirely ignorant of what is involved. Our civic rulers have an unfortunate knack of getting mixed up in affairs that do not in the least concern them, and of which they possess not the slightest degree of knowledge. Calgary, in this respect, is not a whit worse than our other Canadian cities—perhaps they felt they were not quite so advanced in the art of blundering as the Eastern and older municipalities. However, its experience in trying to propagate a municipal foundry may have a deterrent effect on others in the like or equally stupid directions.

INDUSTRIAL ^A_ND CONSTRUCTION NEWS

Establishment or Enlargement of Factories, Mills, Power Plants, Etc.; Construction of Railways, Bridges, Etc.; Municipal Undertakings; Mining News.

Engineering

Peterborough, Ont.—The machine shop recently run by P. H. Spies has been taken by O. A. White and L. Ackford.

St. John, N.B.—Messrs. McAvity & Sons have engaged Messrs. Lockwood & Green, Boston, Mass., to make preliminary plans for their foundry.

Merrickville, Ont.—The Percival Plow & Stove Co., will increase the size of their plant. The municipality will be asked for \$7,000 to enable them to do this.

London, Ont.—The Dennis Wire and Iron Co., will extend their present plant at a cost of \$20,000. Special new machinery and new heating system will be installed.

North Bay, Ont.—The carriage, bolt and blacksmiths shop of Pearl & Sherwin on Foren St., was burned to the ground last week, together with much machinery.

Toronto, Ont.—The Lumen Bearing Co., West Toronto, have broken ground for a substantial addition to their plant, which will afford them facilities for greatly improved service.

Sarnia, Ont.—The first heat of brass to be run off at the H. Mueller Brass Company's factory was poured last week. The company expects to be ready to start manufacturing its products about May 20.

Sudbury, Ont.—The Mond Nickel Co. sustained a loss estimated at \$50,000 to \$100,000 when its building at Victoria Mines, containing electrical machinery, dynamos, etc., was totally destroyed by fire.

Lindsay, Ont.—The ratepayers have passed the by-law granting \$10,000 to the Canadian Boving Co., Toronto, who have assumed the property and plant of the Madison-Williams Co. manufacturers of hydraulic and other machinery.

Estevan, Sask.—The Dominion Odie Company, Ltd., has signed a contract for the town to erect a factory to manufacture electric motors. The plant will cost about \$50,000, and the company is said to have a capital stock of \$1,000,000.

Brantford, Ont.—The Brantford Machinery & Foundries, Ltd., recently organized, will build a plant consisting of a foundry and machine shop for the manufacture of machine tools. H. B. Rowell of the Brantford Autocycles, Ltd., is interested.

Brantford, Ont.—Following an offer of a free site, etc., made by Industrial Commissioner Emerson, it is likely that the Coniagas Mines, Ltd., smelting plant will be moved to this city from Thorold, Ont. It is necessary for the present plant at Thorold to be enlarged. The directors will consider the removal at their next meeting.

Electrical

Port Dover, Ont.—The ratepayers will shortly vote on a by-law authorizing the installation of a complete new hydro-electric system. Reeve Vyes is in charge.

Windsor Mills, Que.—The Canadian Paper Co., have purchased water power in the vicinity, for over 1,000 h.p., from which they will generate power for their mills.

Medicine Hat, Alta.—The ratepayers will decide on Thursday, May 22nd, whether the franchise for a street railway shall be awarded to the Montreal Engineering Co.

Berlin, Ont.—The Dominion Tire Company, which is completing a new \$300,000 industry in the west ward, has decided to erect a power house to cost \$50,000. Work will commence immediately.

Berlin, Ont.—The Berlin Steam Heating Co. has offered to sell its plant to the City Light Commission. Owing to the company not being permitted to sell electricity in the city the enterprise is not proving a financial success. The commission has asked the company to place a figure on the plant, and if satisfactory, it is probable steps may be taken to acquire this utility.

Water-Works

Port Edward, B.C.—A waterworks system to cost \$30,000 is being planned for Port Edward.

St. Alexis, Que.—On May 20th the ratepayers voted on a scheme to spend \$33,000 on a waterworks and sewerage system.

Bedford, Que.—The town is considering the construction of a waterworks system and has engaged the services of a consulting engineer.

Ottawa, Ont.—The Private Bills Committee has passed a bill which authorized the city of Ottawa to go to the Gatineau Lake for its new water supply.

South Vancouver, B.C.—The Water and Light Committee have decided to purchase a 1,000,000 gallon capacity pump and construct a 100,000 gallon wood tank, and a 750,000 gallon steel standpipe.

Edmonton, Alta.—The city council have decided that the Rabbit Hills will be the source of the city's water supply. The pumping station will be located nine miles up the river, where the water will be pumped and filtered, and then brought by gravity seven and a half miles. The estimated cost is \$3,140,000.

Wood-Working

Scotstown, Que.—Work on a new chair factory has been begun here. Mr. Couillard is the manager.

Athabasca, Alta.—E. C. Groves, of Edmonton is here arranging for the erection of a sash and door factory, which will be equipped with the best machinery.

Southampton, Ont.—The Goderich Lumber Co.'s sawmill at Southampton was destroyed by fire May 16. Repairs had just been completed after Good Friday's storm, and work was about to be resumed.

Municipal

Galt, Ont.—The ratepayers will be asked to vote \$60,000 to carry out the proposal for a new trunk water main.

Berlin, Ont.—A by-law to raise \$30,000 for the purpose of laying a mile of double track and paving King Street, was carried last week by a majority of 66.

Vancouver, B.C.—The city is in the market for two city service trucks and one combination hose wagon and chemical, each motor driven. Tenders received up to June 12th.

Scotstown, Que.—The town council have placed a contract with Charles A. Paquette & Co., Quebec, for a road machinery plant to be used in macadamizing the roads of the municipality.

Building Notes

Edmonton, Alta.—A large machinery warehouse will be erected here by the Rumely Products Co., Ltd.

Toronto, Ont.—The Methodist Church will erect a six storey building of steel and terra cotta, costing \$1,000,000. Tenders will be called for shortly by the Book and Publishing Committee.

Toronto, Ont.—A permit has been granted to Samuel Benjamin & Co., dealers in metals, to build a six storey addition to their building at King St. and Spadina Avenue. The structure will be brick, steel and reinforced concrete, and will cost \$65,000.

General Industrial

Lennoxville, Que.—The Lennoxville Creamery was burned to the ground last week.

Port Dover, Ont.—Carpenter Bros., of Winona, Ont., will build a cannery here at a cost of \$15,000.

Port Dalhousie, Ont.—The Port Dalhousie Canning Co., have awarded the contract for building their new factory here to Newman Bros., St. Catharines, Ont., at a cost of \$50,000.

Lindsay, Ont.—The Fitzsimmons Automobile Body Works Co., are building an addition to their automobile factory on Wellington Street. Mr. J. A. Fitzsimmons is the manager.

Saskatoon, Sask.—Crushed Stone & Gravel, Ltd., will establish a branch at Moose Jaw, where they have 150 acres of gravel land. Machinery has already been shipped. H. C. Struchen is the head of the company.

Sherbrooke, Que.—The Connecticut Cotton Mills Co., Ltd., will build a plant here, and have already disposed of their products for five years to four principal tire manufacturers. John Lowe of Valleyfield, Que., is general manager.

Sherbrooke, Que.—The Elwell Rubber Co., a branch of the company in Stoughton, Mass., will locate their plant

here. They will purchase the old Sherbrooke Iron Works from the Sherbrooke Railway and Power Co., and will spend \$50,000 for machinery and repairs. They will employ 50 hands.

Brantford, Ont.—The announcement has been made by the Brantford Roofing Company that it has purchased the Canadian rights of an American roof paint, and will manufacture it at Brantford. A building is now being erected, and within three weeks a plant will be in operation for the manufacture of such paint.

Patent Sold.—P. J. Edmunds of London, Ont. registered attorney and solicitor of patents, has just put through a big deal with some Eastern capitalists for Frederick J. Watkinson, of Strathroy, Ontario, for his invention for "window sash, pulleys and weather strip." The papers have just been signed and Mr. Edmunds has been instructed to apply for patents in 12 of the principal foreign countries.

St. John, N.B.—The Mollassine Mfg. Co., will be organized here with a capital of \$250,000, and will build a factory employing several hundred men. They are buying out the L.C. Prime Co. of this city. The board of directors will consist of Messrs. Benjamin Horton, L. B. Knight, L. C. Prime, F. R. Taylor and Mr. John Prosser. Mr. Taylor will be the legal adviser of the company; Mr. Knight will be president; Mr. Prime, general manager, and Mr. W. J. McAuley, secretary-treasurer.

Railways—Bridges

Prince Rupert, B.C.—The city will build a steel bridge at a cost of \$35,000 over Morse River. Engineer, W. G. Mason.

Truro, N.S.—The C.P.R. are rapidly rebuilding the Dominion Atlantic line recently acquired. Several new bridges are being built.

Calgary, Alta.—The city engineer, G. W. Craig is preparing plans to bridge over the Bow and Elbow Rivers, for a special committee of the council.

Fort William, Ont.—The new C. P. R. bascule bridge across the Kaministiquia River, is practically finished. It is a combination bridge for both railway and highway traffic.

Sutton, Que.—The town council have awarded a contract for material on the Shepard Bridge across the Mississquoi River to Mackinnon, Holmes & Co., of Sherbrooke, Que.

Winnipeg, Man.—A train of forty cars loaded with locomotives, steam

shovels, boarding cars, flat cars, ballast plows and innumerable other necessary articles for use in a construction camp, left the C. N. R. yards April 30 for the J. D. MacArthur Co., Ltd., in its work on the Hudson Bay railway between Lepas and Port Nelson.

Galt, Ont.—According to W. J. Coleman, manager of the Dominion Power and Transmission Co., of Hamilton, Ont., construction work will start soon on a radial electric line from Hamilton to Galt. The route will be that already surveyed by the company, via Lynden and Troy, to a point west of Sheffield, and then parallel to the Stone Road, entering Galt by way of East Main Street, with the idea of making a union station at the terminal of the Lake Erie and Northern Railway.

Contracts Awarded

Calgary, Alta.—A contract for building schools has been let to R. A. Brooklebank for \$163,000.

Regina, Sask.—The G.T.P. will start at once to build a \$1,000,000 hotel here. The Lyall-Mitchell Co. have the contract.

Peterboro, Ont.—A contract for the foundations of the new Vermont Marble Co.'s plant has been let to F. F. Mahood, of Downer's Corners, Ont.

Kingston, Ont.—Fallon Bros., of Cornwall, Ont., have been awarded a contract to construct the Kingston harbor breakwater, at a cost of \$212,000.

Toronto, Ont.—The Canada Foundry Co. have been awarded the contract for supplying the structural steel for the new Loew Theatre on Victoria Street.

Edmonton, Alta.—The city commissioners have awarded the W. H. Allen, Son & Co., Bedford, England, the contract for supplying an 18,000,000 gallon low lift pump.

Winnipeg, Man.—The Canadian Steel Pipe Co., Winnipeg, have been awarded the contract for supplying the city of Minneapolis with 10,000 feet of 48 inch lock bar steel pipe.

Ottawa, Ont.—The Canadian Government has awarded the contract for the machinery for dredges at the Hudson Bay terminal to F. H. Hopkins & Co., Montreal, for \$13,500.

Quebec, Que.—A contract for the Chateau d'Eau in connection with the new Quebec Water Works has been awarded to the Lauzon Engineering Co., of Levis, Que., for \$21,300.

Vancouver, B.C.—The Canadian Northern Railway have awarded the

Carnegie Company, of Pittsburg, Pa., the contract for the erection of the car-building works at Port Mann.

Brantford, Ont.—The Pratt & Letchworth Co., whose plant was recently burned have awarded a contract to B. H. Secord & Sons for a new building, costing \$20,000; work to start immediately.

Quebec, Que.—The work on the Quebec-Montreal highway will commence in a few days. Mr. Henri Beauregard of Montreal being the contractor. The contract calls for its completion by November 1915.

Vancouver, B.C.—The British Columbia Railway Co., have awarded a contract for their new \$40,000 club house for employes to George Snider & Brethour. Kydd Bros. will install the heating apparatus.

Hamilton, Ont.—The contract for building a factory extension to cost \$250,000, Terra Cotta Avenue, for Fowler's Canadian Co., Wentworth Street north, has been let to R. S. Bloom Company, Chicago, Ill.

Moncton, N.B.—The city has awarded Babcock and Wilcox, Limited, Montreal the contract for supplying a strainer, and the John McDougall Canadian Iron Works Co., Montreal, the contract for supplying a Venturi water meter.

Vancouver, B.C.—Contracts for the construction of five bridges on the Kettle Valley line between the Coldwater loop and the summit have been awarded to McEachren & Clark, by Twohy Bros., general contractors for a part of the line.

Leamington, Ont.—The contract for the new factory of the German-Eckert Company of London, for handling vegetables, making tomato sauces and preserving and canning fruit, has been let to Link & Roche, who will push the work rapidly.

Aylmer, Que.—A special meeting of the town council was held May 12, and the tenders for the new roads to be built through the town were considered. The tender of Secord & Son, of Brantford, was accepted, and the contract awarded this firm.

Fort William, Ont.—The Burrell Engineering & Construction Co., of Chicago, have been awarded the contract for erecting a Western Terminal Elevator in Fort William, and work on the foundation has already commenced. John E. Todd is General Superintendent of the company.

St. Thomas, Ont.—The DesMoines Bridge and Iron Company of Pitts-

burgh, Pa., has received the contract for a new steel standpipe to be erected in the city by the water board. The contract for the new boilers was not awarded, it being decided to go into the figures more fully.

Blenheim, Ont.—The first sod was turned Tuesday in the construction of the new factory at Blenheim of the British-Canadian Cannery, Ltd., of Hamilton. The contractor, A. E. Ponsford, of St. Thomas, went to Blenheim, and after consulting with the head officers of the company, who were also present from Hamilton, it was decided to alter the plans so that the building will be constructed entirely of brick.

Montreal, Que.—The Western Power Company, Limited, have awarded the contract to the Escher, Wyss & Company of Zurich, Switzerland, for supplying two additional 13,000 h.p. double Francis turbines. The Canadian General Electric Company the contract for two additional generators of corresponding capacity. The Canadian Westinghouse Company, Limited, for switchboards and accessories to complete the power house extension.

Quebec, Que.—The contract for the construction of the new Provincial Forestry School, to be erected on Hebert Street, joined with Laval University have been awarded as follows:—Masonry, Chas. N. Paradis, of St. Saneur; woodwork, L. H. Peters; roofing, Eug. Falardeau; plumbing, Jobin & Paquet; steel work, Eastern Canada Steel and Iron Co.; glass and windows, Gauthier Co.; fire-proof floors, Art Laurent. The cost of the entire construction will be \$106,000.

Swift Current, Sask.—The city will discard its gas producer plant and will install a steam plant. The old power house will be used as a pumping station. Contracts have been let for 300 h.p. Babcock and Wilcox watertube boilers, for \$15,460; for a 300 h.p. and a 500 h.p. high-speed reciprocating engine to Messrs. Goldie & McCulloch, of Galt, Ont., for \$16,195; and for a 200 h.p. and 400 h.p. a.e. generators for the Allis-Chalmer-Bullock Co., of Montreal, for \$11,500. The engineers in charge of the work are John Maddin, Winnipeg, and the city engineer, Geo. D. Mackie.

Tenders

Montreal, Que.—The Board of Control will receive tenders until June 12th for a 1,000,000 gallon electric pump. Engineer, T. W. Lesage.

St. Vital, Man.—Tenders will be received up till the 12th of May, 1913, for the erection of a steel tower water tank.

Plans may be obtained from G. R. Caldwell, acting minister of public works.

Lachine, Que.—Tenders will be received up till the 12th of May for the installing electric light system and construction of drainage and waterworks system. Hector Charette, City Clerk.

Moose Jaw, Sask.—Tenders will be received up till the 11th of May, 1913, for the construction of a street railway. Plans and specifications may be obtained from Robt. A. Grant, Winnipeg, Man.

Montreal, Que.—The Canada Brick Company, Transportation Building, contemplate purchasing brick-making plant, sand lime presses, etc., motor truck 5 to 7 tons, gasoline or electric. Mr. Henriels in charge.

Medicine Hat, Alta.—Fraser & Chalmers were unable to instal machinery at the waterworks according to contract, for May 1, but will have temporary machinery in place by July 15. The city has agreed to this.

Winnipeg, Man.—The C. P. R. have called for tenders for the construction of a tunnel through the Selkirk mountains, and for part of the double tracking scheme for the coast. The tunnel will be five and two-thirds miles in length.

Kamloops, B.C.—Tenders will be received up till June 12th by J. J. Carment, city clerk, Kamloops, on three water wheels, generators, exciters, transformers and switching equipment for the proposed hydro-electric power plant. Plans at the office of DuCane, Dutcher & Co., consulting engineers, Vancouver, B.C.

South Edmonton, Alta.—An electric lighting plant, outside the city limits is contemplated by a syndicate of which the president is A. C. Todd; vice-president, J. M. Douglas, 155 Saskatchewan Ave.; secretary-treasurer, A. L. Marks, 648 6th Ave north-east. Will instal independent plant to provide light and power for factory.

Calgary, Alta.—The Bowness Investment Co., of Calgary, will receive tenders up to May 31st, 5 p.m., for the following machinery and equipment: "A" 2 alternating current generators. "B" 2 direct connected exciters; one motor-driven exciter set. "C" 1 six panel switchboard. "D" 1 series tungsten lighting system. "E" transmission lines and underground cable. "F" 2 vertical multi-cylinder internal combustion engines.

Marine

Collingwood, Ont.—The James Carruthers, a big freighter on the stocks

here, will be launched in about two weeks.

Ottawa, Ont.—The Government will ratify and confirm an agreement with the Western Dry Dock and Shipbuilding Co., Ltd., respecting the construction of a dry dock at Port Arthur, Ont., paying the company a subsidy of 3 per cent. per annum for 20 years on the sum of \$1,250,000—the cost of constructing the dock.

Montreal, Que.—A contract for the construction of a large freighter was closed by the American Shipbuilding Co., with Canadian interests in this city, last week. The boat will be built in Port Arthur, and will be 625 feet over all, and will have a capacity of 450,000 bushels. She will be fitted with Scotch boilers and triple expansion engines.

Port Stanley, Ont.—Work will soon be commenced by the Government on improvements to Port Stanley Harbor. The original plans are for a breakwater along the east side, 100 feet long. The harbor is to be deepened sufficient to admit boats with a draught 18 ft. 7 ins. Major H. J. Lamb, Windsor, is the Government representative in Western Ontario.

Trade Gossip

The Toronto Pattern Works are moving from 87 Jarvis Street to much larger quarters at 65 Jarvis Street.

The Detroit Sheet Metal Works, are removing their plant from 136 John St., to 592-598 Yonge St., Toronto. They are manufacturers of automobile sheet metal parts, and do high grade brass and bronze work and coppersmithing. This is a new concern, having been in operation only about two or three months. Mr. I. R. Schonitzer is manager.

The Smart Turner Machine Co., Hamilton, Ont., have recently booked the following orders:—J. B. Laberge & Sons, Sudbury, Ont., one automatic feed pump and receiver equipment; E. D. Smith, Winona, Ont., duplex pump; The Riordon Pulp and Paper Co., Merriton, Ont., centrifugal pump; Price Bros. & Co., Kenogami, Que., centrifugal pump; the Dominion Abattoir Co., London, Ont., triplex power pump; the Thunder Bay Contracting Co., Port Arthur, Ont., steam engine driven centrifugal pump; the Steel Co. of Canada, centrifugal pump.

Salesmen Banqueted.—The traveling salesmen of the Fairbanks-Morse Co., who were in Saskatoon attending the company's convention, were banqueted at the Saskatoon club by S. H. Crane, manager of the local branch. A

pleasing incident of the occasion was the presentation of an appropriate gift to P. E. Floyd, manager of the electrical department by his fellow employees because of his recent marriage. After the banquet, the heads of the departments held a meeting and discussed conditions. The prospects for the coming year are excellent and collections are getting better.

The P. L. Robertson Mfg. Co., Ltd., Milton, Ont., have purchased the plant, assets and business of the Toronto Wire Nail and Tack Co., West Toronto (Edwin Ave. and C.P.R. tracks), which up to the present has been privately owned, and did a local business in wire and wire nails. The Robertson Co. will build warehouses on the property, and will carry a full line of screws, rivets of all kinds, nails and wire, and will be in an excellent position to serve the markets of Toronto and vicinity from these works. The company propose to manufacture bolts and nuts very shortly, and plans for large additions to the screw end of the business are well in hand. The history of this company has been one of gradual progress. In 1912, a wire drawing nail plant was added to the works at Milton, Ont., in which the firm had for some time been manufacturing their well known socket head wood screw. Following the erection of this plant the manufacture and sale of wire, wire nails, rivets and screws was pushed vigorously, so that the shareholders recently found the company in a very prosperous condition. Other additions have been made recently to the Milton works in the matter of buildings and machinery.

Personal

C. R. Murdock, of the firm of Chipman & Powers, engineers, Toronto, has been in Watrous, Sask, superintending work on water works, and sewerages, but has returned to High River, where he is engaged on a similar class of work. He stopped en route at Kerrobert which town is spending \$865,000 on water works system.

Archibald Currie, C.E., at present city engineer of westmount, has been chosen by the Board of Control of Ottawa to fill the position of city engineer in that city. Mr. Currie has already signified his intention of accepting the post, and will take up his new duties on June 20. His salary will be \$5,000 per year, to be increased to \$6,000 after the first year, if the civic authorities are satisfied.

D. MacD. Campbell, city engineer of Sydney, N.S., tendered his resignation to the Board of Works last week, and

it was accepted. Poor health is given as the cause, and Mr. Campbell will not enter the services of any other corporation, but will engage in private work. Mr. Campbell entered the service of the city as a member of the city engineer's department in 1900. For several years he was assistant to Mr. Yorston, and on the latter's resigning in 1908, succeeded to the position.

Obituary

W. H. Weber, manager of the Electric Meter and Stamping Works, New Hamburg, Ont., fell from a gangway and was instantly killed on May 13.

J. Walter Martin, president and manager of the Gurney-Tilden Co., of Winnipeg, and vice-president of the Stove & Heater Co. of this city, died suddenly in Chicago on Saturday, May 10th.

Catalogues

H. W. Johns-Manville Co., with offices practically everywhere, make asbestos, magnesia and electrical products. They make so many lines. For the benefit of the consumer they have issued a folder containing a list of goods made in their plant, with a postcard attached, handy to mail for particulars.

The United States Electrical Tool Co., Cincinnati, Ohio, have favored us with copy of catalogue "H". It deals with electrical hand or breast drills, electrically driven grinders, etc. These are machines which may be taken to the work, and the lamp socket is the only power house required. Space cannot be given here to tell of the excellent photographs in this catalogue showing how these tools may be used as time-savers. At the end are several instructions on how to take care of electric tools. The uses to which electric tools may be put are so many, that no one should be without this booklet.

The Hissey Wolf Machine Co., Cincinnati, Ohio, makers of portable electric machine tools, issue a challenge in a folder just received to the effect that it is better than a ten-to-one bet that those who send for a "Hissey" portable electric tool on the trial plan, will prefer to keep it than to keep shop without it. They make tool post grinders. For external, internal and parallel grinding, bench, pedestal and aerial grinders, as well as hand, breast, screw fed, radial and sensitive drills, all operated by self contained motors. Reader's are invited to send for this firm's catalogue, which describes all types.

The General Market Conditions and Tendencies

This section sets forth the views and observations of men qualified to judge the outlook and with whom we are in close touch through provincial correspondents.

Montreal, May 19.—In the machine tool market generally there is marked quietness, and while the optimism is being taxed severely, dealers hope that within a couple of weeks they will have more to do than they can handle. One of the largest supply houses of railway and contract material said that they had enough business in sight to warrant every hope of remarkable activity in the near future. The story of the country's prosperity is indexed best in the Government budget just issued, showing the enormous increase of imports and markedly so from our neighbors in the South. The activities of the steel mills in the United States have not diminished, and while orders are reported small, specifications are heavy.

Pig Iron and Copper.

No changes have been reported in pig iron except that in some quarters there has been an improvement noted in the demand for foundry grades. Steel making iron is said to be easier in the big markets, but no pronounced changes have taken place here. Scattered strikes at ore mines, blast furnaces, and at certain foundries have been given as reasons for falling off of shipments in the States. Iron has receded some all around, but most likely will resume its strength by another week, and we have been instructed not to change the prices. In copper there have been little flutters, but no vital change. There was a slight easing in price for June and July shipment in the States. The European demand has been again stimulated, and interest has been awakened by the big shipments to the Old Land. Whatever is on the water is not included in the statistics, and, judging from the figures, there must be a large amount of copper in storage in the Old Country. The most striking feature reported is that melting goes on apace in European countries as well as on this continent, while there has been a notable falling off in the volume of new business. There were slight decline in New York and London, but our price is normal and needs no change.

Metals and Old Material.

Tin suffered a severe break last week, and is down a couple of cents, but at the rate it has been fluctuating it is likely to go up or down at any time. Futures in the big markets went down in sympathy with London, and the net decline would average about a cent and a half all round. This was, of course,

after the recovery which took place on Saturday. Immense shipments took place from the Straits to this continent and to Europe. Standard contracts from London were reported irregular, unsettled and lower. Antimony and spelter are unchanged and uninteresting. From some of the big American markets it was heard that spelter was easier and dull, and much the same market was obtaining for lead. In old material, the market is described as dull, heavy and lower.

Toronto, May 21, 1913.—The sensation in local machinery circles for the last two or three days has been the purchase by the A. R. Williams Co., of the entire stock of the Canadian Gas Power & Launches, Ltd., which was sold out by a liquidator last week. The attendance at the sale was very meagre, and as A. R. Williams were making bids for most of the machinery they were asked to make an offer for the whole of it, which they did. The Canadian Gas Power and Launches, Ltd., went into liquidation three or four years ago, and the machinery has been lying idle ever since. A. R. Williams have already sold much of the equipment. The De Laval Dairy Supply Co., of Peterboro, Ont., purchased two cart loads; Goold, Shapley & Muir, Brantford, Ont., bought quite a large quantity of machine tools; the Dominion Cannery, Simcoe, Ont., bought several lathes, and a couple of boring mills went to Meyer Bros., Toronto, makers of laundry machinery. This secondhand material was therefore disposed of very rapidly, and has eclipsed all other sales of machine tools during the week. Small orders for equipment continue to come in, but there is little improvement over last week.

Pig, Iron and Steel.

There was a report in one of the Toronto newspapers this week to the effect that the United States Steel Corporation had decided to delay construction work on their new mills at Sandwich, Ont., for two years. The local representatives of the Steel Corporation was questioned on the matter, and declared that he had no reason to believe it. The rumor, he stated, had reached his ears, but he had heard nothing of it officially. He seemed very pessimistic about the present condition of business, but remarked that it was keeping up well, and that there was still lots offer-

ing. He added that deliveries were not up to the mark. There has been no change in prices in American steel offered in Canada. A prominent Canadian dealer in steel reported that business was no better this week than last, and that prices were unchanged. He, however, expressed the belief that things would pick up again by June 1. The month of May, he reported, was always an off month, business being also very bad this time last year. The city representative of another large steel concern was quite frank in the matter (which he generally is not), admitting that business was very very poor, that manufacturers were not buying either pig iron or steel, and that the tightness of money was suspending building operations and consequently curtailing the sale of reinforcing steel. Some time ago there was a note in "CANADIAN MACHINERY" to the effect that the Dominion Steel and Iron Co., of Sydney, N.S., had opened an office at the bottom of York St. It seems that Mr. Max Morrell took ill last week, and was unable to open the office as expected, but will do so this week. He will be found at 18 Wellington St., E. The Merchants Mutual Line shed is being used for storage purposes. We understand that nails will be carried at first, to be followed later, possibly by wire and steel bars.

Metals.

There is practically no change in the metal market. It will be noted, however, that tin 50½ cents in Montreal, and 51 cents in Toronto; being a slight reduction on last week's price. There is no scarcity, and little demand. Business is decidedly quiet. Aluminum is 2 cents higher this week in Toronto, being now 23 cents.

Coke.

This market is the same as last week, the price remaining at the low levels assumed when the drop took place in the United States. Business is reported good by Toronto dealers.



Cities Play tug-of-war.—Kingston is putting up a fight to get an industry that has been promised to Trenton, and the chances that Kingston will beat Trenton are very slight, on account of their having only one main line of railway, which is some distance from the town. The company is capitalized around a million dollars, and has assured the Industrial Commissioner that Trenton is the place. —Trenton Courier.

Why can't a compromise be arranged by locating it between the two towns—at Belleville? Suppose Belleville gets busy.

SELECTED MARKET QUOTATIONS

Being a record of prices current on raw and finished material entering into the manufacture of mechanical and general engineering products.

PIG IRON.

	Per Ton.	
Foundry No. 1 and 2, f.o.b., Midland	\$19 00	\$19 50
Gray Forge, Pittsburgh	16 15	
Lake Superior, charcoal, Chicago	18 00	
	Mont'l. Tor'to.	
Canadian f'dry, No. 1..	\$21 00	\$20 00
Canadian f'dry, No. 2..	20 50	19 50
Middlesboro, No. 3....	23 50	23 50
Summerlee, No. 2	25 00	26 50
Carron, special	25 00
Carron, soft	25 00
Cleveland, No. 1	24 25	25 00
Clarence, No. 3	23 75	24 50
Jarrow	25 50	
Glengarnock	26 00	
Radnor, charcoal iron.	30 00	34 50
Ferro Nickel pig iron (Soo)	25 00	

BILLETS.

	Per Gross Ton.	
Bessemer billets, Pittsburgh	\$28 50	
Open hearth billets, Pittsburgh.	29 00	
Forging billets, Pittsburgh.....	36 00	
Wire rods, Pittsburgh	30 00	

FINISHED IRON AND STEEL.

Per pound to large buyers:

	Cents.
Common bar iron, f.o.b., Toronto..	2.10
Steel bars, f.o.b., Toronto.....	2.20
Common bar iron, f.o.b., Montreal.	2.15
Steel bars, f.o.b., Montreal.....	2.25
Bessemer rails, heavy, at mill....	1.25
Iron bars, Pittsburgh	1.70
Steel bars, Pittsburgh, future	1.40
Tank plates, Pittsburgh, future...	1.45
Beams, Pittsburgh, future	1.45
Angles, Pittsburgh, future	1.45
Steel hoops, Pittsburgh	1.60

Toronto Warehouse f.o.b., Toronto.

	Cents.
Steel bars	2.30
Small shapes	2.40
Warehouse import, freight and duty to pay:	Cents
Steel bars	1.95
Structural shapes	2.05
Plates	2.05
Freight, Pittsburgh to Toronto:	
18 cents carload; 21 cents less carload.	

BOILER PLATES.

	Mont'l. Tor'to.	
Plates, ¼ to ½-in., 100 lbs.	\$2.35	\$2.35
Heads, per 100 lbs.....	2.65	2.95
Tank plates, 3-16 in.	2.60	2.60
Tubes, per 100 ft., 1 inch	9.00	8.50
" " 1¼ in.	9.00	8.50
" " 1½ "	9.00	9.00
" " 1¾ "	9.00	9.00
" " 2 "	8.75	8.75
" " 2½ "	11.50	11.50
" " 3 "	12.00	12.00
" " 3¼ "	13.75	13.75
" " 3½ "	14.50	14.50
" " 4 "	18.00	18.00

BOLTS, NUTS AND SCREWS.

	Per cent.
Stove bolts	80 & 7½
Machine bolts, ¾ and less	65 & 5
Machine bolts, 7-16.....	57½
Blank bolts	57½
Bolt ends	57½
Machine screws, iron, brass	35 p c.
Nuts, square, all sizes.....	4c per lb off
Nuts, Hexagon, all sizes..	4¼ per lb off
Flat and round head.....	35 per cent.
Fillister head	25 per cent.
Iron rivets	60, 10, -0 off
Wood screws, flathead, bright	85, 10 p c off
Wood screws, flathead, brass	75, 10 p c off
Wood screws, flathead bronze	70, 10 p c off

National-Acme "Milled Products."

Sq. & Hex Head Cap Screws	65 & 10%
Sq. & Hex Head Cay Screws	65 & 10%
Rd. & Fil. Head Cap Screws	45-10-10%
Flat & But. Head Cap Screws	40-10-10%
Finished Nuts up to 1 in. ..	75%
Finished Nuts over 1 in. ..	72%
Semi-Fin. Nuts, up to 1 in....	75%
Semi-Fin. Nuts over 1 in.....	72%
Studs.....	65%
Discounts f.o.b., Montreal.	

WROUGHT IRON PIPE.

The following are Toronto jobbers' discounts on pipe in effect from April 21, 1913:

Standard	Buttweld		Lapweld	
	Black	Gal.	Black	Gal.
¼ ¾ in.	62	47
½ in.	68	58
¾ to 1½	71½	61½	68½	58½
2 in.	71½	61½	68½	58½
2½ to 4 in. ..	71½	61½	70½	60½
4½ to 6 in.	71½	61½
7, 8, 10 in.	66	54

X Strong P. E.

¼, ⅜, ½ in. ..	56½	46½
¾ to 1½ in. ..	67½	57½
2 to 3 in.	68½	58½
2½ to 4 in.	65	55
4½ to 6 in.	64	56
7 to 8 in.	55	45

XX Strong P. E.

½ to 2 in.	43	33
2½ to 4 in.	43	33

PRICES OF WROUGHT IRON PIPE.

Standard.	Extra Strong.	D. Ex. Strong.
Nom. Price.	Size Price	Size Price
Diam. per ft.	Ins. per ft.	Ins. per ft.
1/8 in \$.05½	1/8 in \$.12	1/2 \$.32
1/4 in .06	1/4 in .07½	3/4 .35
3/8 in .06	3/8 in .07½	1 .37
1/2 in .08½	1/2 in .11	1¼ .52½
3/4 in .11½	3/4 in .15	1½ .65
1 in .17½	1 in .22	2 .91
1¼ in .23½	1¼ in .30	2½ 1.37
1½ in .27½	1½ in .36½	3 1.86
2 in .37	2 in .50½	3½ 2.30
2½ in .58½	2½ in .77	4 2.76
3 in .76½	3 in 1.03	4½ 3.26
3½ in .92	3½ in 1.25	5 3.86
4 in 1.09	4 in 1.50	6 5.32
4½ in 1.27	4½ in 1.80	7 6.35
5 in 1.48	5 in 2.08	8 7.25
6 in 1.92	6 in 2.86
7 in 2.38	7 in 3.81
8 in 2.50	8 in 4.34
8 in 2.88	9 in 4.90
9 in 3.45	10 in 5.48
10 in 3.20
10 in 3.50
10 in 4.12

IRON PIPE FITTINGS.

Canadian malleable, 40 per cent.; cast iron, 65; standard bushings, 70; headers, 60; flanged unions, 65; malleable bushings, 65; nipples, 75; malleable, lipped unions, 65.

COKE AND COAL.

Solvay Foundry Coke	5.95
Connellsville Foundry Coke	5.45
Yough, Steam Lump Coal	3.83
Penn. Steam Lump Coal	3.63
Best Slack	2.95
All net ton f.o.b. Toronto.	

Description of New C.P.R. Shops, Ogden, near Calgary, Alta.

By C.T.D.

About a year ago we published a comprehensive article dealing with the New Shops of the National Transcontinental Railway, located at Transcona, near Winnipeg. The present article, dealing with the enterprise of the C. P. R. in Western Canada, although less elaborate, gives in concise form the main features of the complete provision made by a great railroad, to maintain its rolling stock in perfect service condition at a point far removed from and inconvenient of handling at its eastern headquarters.

THE Canadian Pacific Railway Co. has recently put in operation, at Ogden, near Calgary, Alberta, a large shop plant of more than ordinary interest by reason of its size, its complete and modern character and the speed with which it was created. The work was designed and built in entirety by Westinghouse Church Kerr Co., consulting and constructing engineers, of Montreal and New York, working under the direction of Mr. J. C. Sullivan, Chief Engineer of the Western lines of the Canadian Pacific Railway, and Mr. J. E. Brooks, Divisional Engineer.

Problems Due to Location.

The shop location at Ogden (named in honor of the vice-president of the railway), and 4½ miles from Calgary and about 2,250 miles from Montreal. Its distance from these sections of the country where the greater part of the construction materials, machinery and equipment were produced, constituted the first and one of the most important problems. A second important problem arose on account of the construction season being extremely short, owing to the high latitude, frost remaining in the ground until about April 1st, and returning with snow as early as October first. A third very important problem was the comparative scarcity of labor in the Canadian North-west, this condition being greatly aggravated during the late summer months when harvesting begins and all labor markets are practically drained of men. Plans had, therefore, to be drawn, materials ordered, deliveries made and complete field organization perfected so that the shops could be closed in between April 1st and Dec. 1st, and sufficiently heated so that inside work could be continued after cold weather had set in. How this was done will be seen from the accompanying progress diagrams.

The plant consists in general of main locomotive shop, including erecting, machine, blacksmith and boiler shops; tender and wheel shop; pattern shop and pattern storage; foundry; storehouse and office buildings; material platforms and scrap dock; oil house; coach repair and paint shop; freight car repair shop; planing mill; boiler and compressor house, and a 1,260 ft. yard crane.

Miscellaneous structures, include transfer table and pit for coach shop, mess hall, driven wells and water tower, all service system, such as drainage, sewage, fire protection, water supply, etc.

Main Locomotive Shop.

This building is designed to contain

the erecting shop, machine shop, blacksmith shop, and boiler shop.

The erecting shop is of the traverse lift-over type; it contains 35 bays, each 22 feet between centres, and is 778 ft. long by 75 ft. wide. The entire area is served by two traveling cranes, carried

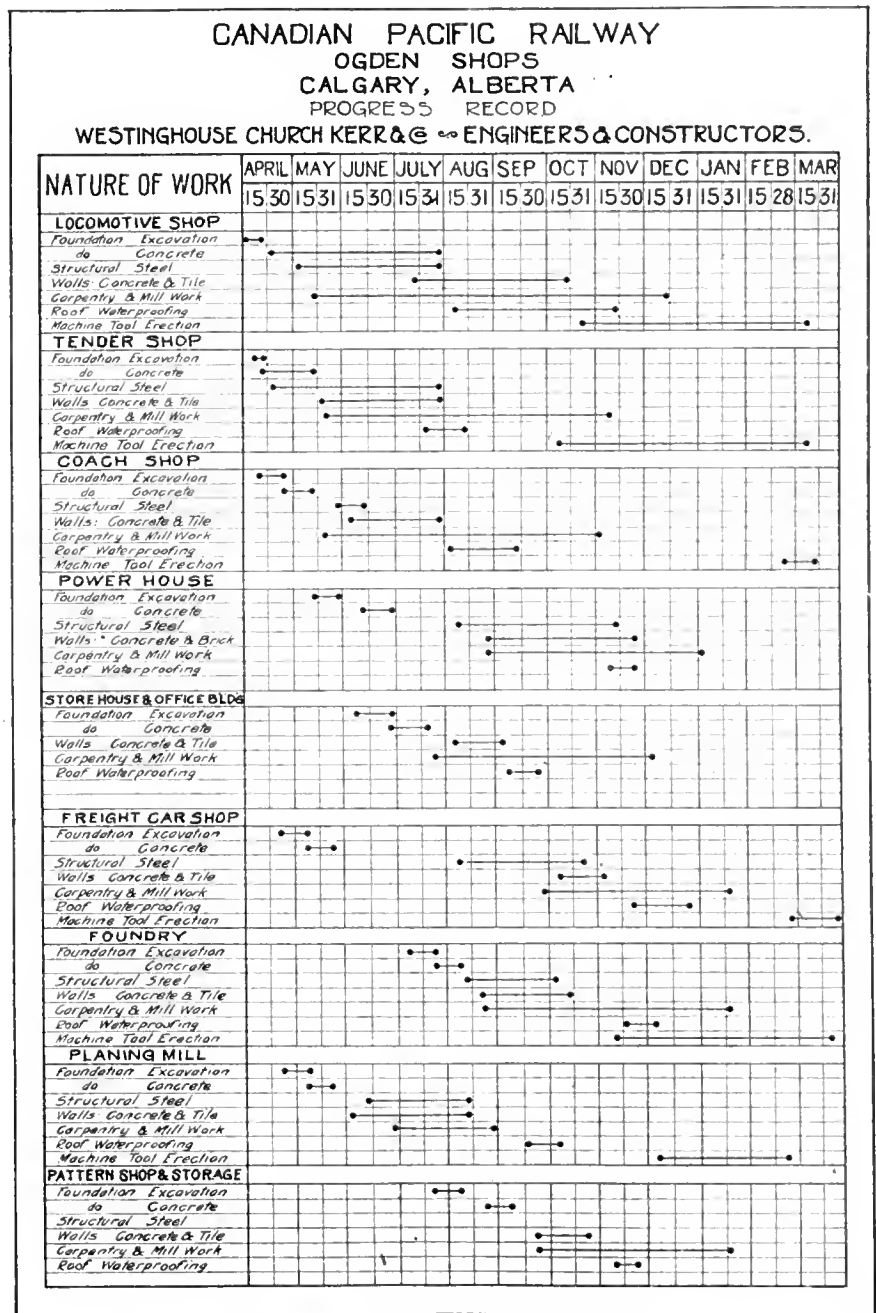

CONSTRUCTION PROGRESS RECORD.

on two levels. A 120 ton crane furnished with two 60-ton trolleys is carried on the upper level and is used for transferring, wheeling and unwheeling locomotives and handling parts. One of the trolleys on this crane is equipped with a ten-ton auxiliary hoist for handling light material at a high hoisting speed. Another ten-ton traveling electric crane operates at high speed and serves the entire area of the erecting shop, for

traveling crane of 10-ton capacity covers the entire area of this shop. Material can be brought in through a door provided in the end of the building, it being brought up to the end of the machine shop by the traveling electric yard crane which travels across the end and outside of the locomotive shop.

Space for the lighter machine tools is provided in a shop 60 ft. 9 inches wide, parallel with and alongside of the

Blacksmith and Boiler Shops.

The blacksmith shop is located alongside of and parallel to the erecting shop on the opposite side of the machine shop. This building consists of two bays each 332 feet long, and 60 feet 9 inches and 50 feet wide, respectively. Space is provided for heavy forging work, steam hammers, etc., in the building immediately adjoining the erecting shop. The blacksmith shop will not be served by a traveling crane, but provision has been made for jib cranes to handle the material from steam hammers, forgings, etc. In a building of lower cross-section alongside, are located the furnaces, bolt headers and other blacksmith shop machinery. This portion is served by a trolley throughout its full length, to facilitate the longitudinal movement of the material.

The space for the boiler shop is provided in a two-bay building, alongside of and parallel with the erecting shop at the end of the blacksmith shop. It is 352 ft. long, and of the same width as the latter. That part of the boiler shop immediately adjoining the erecting shop is provided with a 40-ton traveling electric crane, equipped with two 20-ton trolleys serving the entire area, for handling boilers and other material. The riveting tower is located between two of the roof trusses in the end of the boiler shop, with a 25-ton crane for serving the hydraulic riveter.

In the outer of the two bays of the boiler shop, space is provided for a flue shop and boiler shop tools. The entire length of this space is served by a 3-ton overhead traveling trolley. Space for a flue rattler is provided immediately outside of and adjacent to the low bay of the boiler shop. An entrance track is provided through the outside wall of the



MAIN BUILDING FROM WEST, SHOWING BLACKSMITH AND BOILER SHOP BAYS.

handling material in that shop and transferring same to the blacksmith and machine shop. The machine shop and boiler shop are located in adjacent bays on either side of the erecting shop.

Provision is made on the crane columns in the erecting shop for attaching portable jib cranes for use in dismantling and erecting material on the front ends of locomotives. These cranes are placed where desired by means of the overhead traveling electric cranes. Entrance for locomotives to the erecting shop is provided through four doors, located on the west side, two of these doors being located at either end. For providing additional means for entrance of locomotives, six door openings are provided in the east wall of the machine shop, two of these being at the north and four at the south end. All of these entrance tracks are connected up with the erecting pits of the several stalls where they enter the building, so as to permit of the locomotives moving into and out of the shop through these entrances should this movement become desirable or necessary.

Machine Shops.

The machine shop for heavy machine tools is located parallel with the adjoining erecting shop on one side, and is 60 ft. 9 inches wide and of the same length as the erecting shop. A high speed

heavy machine shop and of the same length as that shop. An overhead trolley beam is also provided on the bottom chord of the roof truss to permit of using a travelling electric trolley for handling material longitudinally. Provision has been made for a foreman's office elevated above the floor and having liberal glass surface in the walls so as to give the best possible view of the shop.



INTERIOR OF PLANING MILL.

boiler shop on which boilers or other equipment going to this department can be delivered on cars under the traveling crane, for unloading, or may be loaded out for shipment in the same way. This facilitates the handling of boilers from steam shovels, pile drivers, Lidgerwoods, etc. Jib cranes are provided for serving the individual machines in the boiler shop where such service may be necessary.

Heating, Light & Power, etc.

The heating throughout is done by indirect fan system, and for distributing the heated air, underground concrete and tile ducts are used.

The general illumination consists of Cooper-Hewitt lamps with circuit and plug boxes for extension loop cords to provide lighting for the interior of the locomotive boilers on the erecting floor.

Toilets, lavatories, and metal lockers are provided in the various departments of this shop.

A suitable system of piping is provided for distributing live steam, compressed air and fuel oil, also water for fire protection, drinking and hydraulic pressure.

Outlets for compressed air are provided in duplicate in the sides of the engine pits to supply operating pneumatic tools.

In the main locomotive shop, the electrical feeders from the power company transmission lines are carried in underground ducts, bringing the current at the voltage delivered by the power company, namely, 2,200 volts, to a sub-station located adjacent to and immediately outside of the low machine bay, the transformers for stepping down to 440 volts being located in this sub-station. In this sub-station, two motor generator sets for supplying direct current are also located. The switchboard is also located in this sub-station for controlling the power and lighting circuits in the machine shop and for the tender shop and foundry. As far as possible, distributing feeders are carried in conduits beneath the shop floor, thereby minimizing the amount of exposed wiring in the shops.

The building containing all of the above departments of the locomotive shop is constructed of structural steel frame carried on concrete foundations. The exterior walls up to the window-sill line are of concrete; above the window sills they are of hollow-tile plastered. Ample window area is provided in the side walls and in roof monitors and skylights so as to give sufficient natural lighting. Good ventilation is obtained through ventilators in the monitors and skylights, and by the use of swinging sashes in the vertical walls.

With the exception of the blacksmith shop and a portion of the boiler shop, the

floor throughout is constructed with a 1½ inch asphalt mastic wearing surface which is underlaid with a rough concrete slab about 6 in. thick. In the blacksmith shop and a portion of the boiler shop, the floor is of cinders. The roof sheathing is constructed of 2 x 4's, surfaced on one side and one edge, and spiked together on edge, thus affording good fire resistance qualities and materially reducing the heat losses. The roof water-proofing is four-ply tarred felt, pitch and gravel, with copper flashing. Suitable drain leaders are provided and connected into underground tiled drains to carry off the water from the roof. The large skylight on the erecting shop bay

In the L portion of the building, of lower cross section, space is provided for steel tire wheel lathes, wheel and axle machinery and such other tools as are required. A depressed tank, carried along the ends of the wheel storage tracks outside, facilitates unloading and loading of wheels and axles. The heating, lighting and service equipment is similar to that described for the main locomotive shop.

Pattern Shop and Pattern Storage.

Space for the pattern shop and pattern storage is provided in a separate building located adjacent to the foundry, a fire wall separating the pattern shop

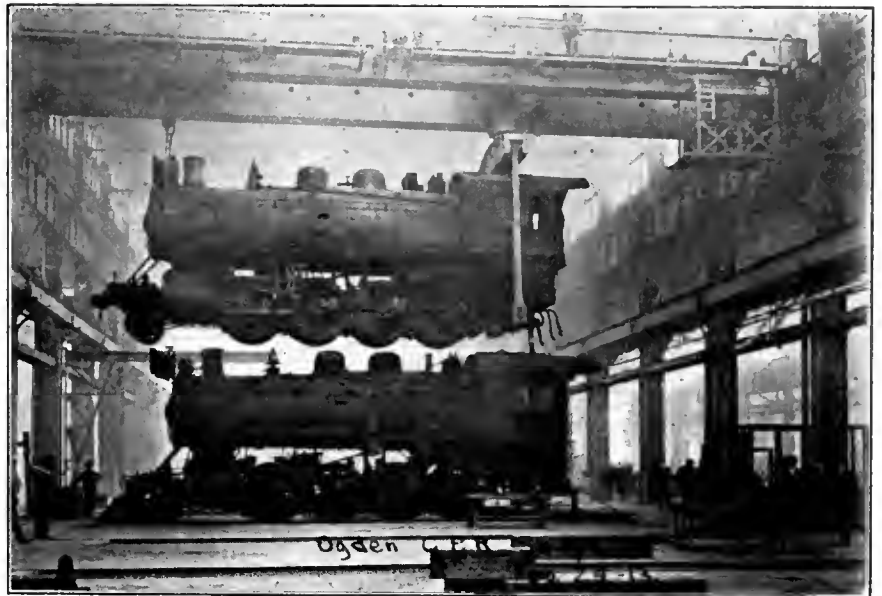

INTERIOR OF LOCOMOTIVE SHOPS, SHOWING 120 TON LOCOMOTIVE CRANE.

is of steel bars, lead covered with ribbed wire glass.

Tender and Wheel Shop.

This building is constructed of structural steel frame and with steel roof trusses, otherwise the general construction of this building is similar to that described for the main locomotive shop. It is an L-shaped structure, 263 ft. x 80 ft., wide, with L-180 ft. long by 80 ft. wide, and affords space for making repairs to locomotive tenders, steam-shovels and other maintenance-of-way equipment. That portion of the shop intended to receive the equipment to be repaired is spanned over its entire area by a 20-ton high-speed traveling electric crane equipped with two 10-ton trolleys. Longitudinal tracks on 20 foot centres extend to the doors in the building wall, and a car puller is installed for moving the equipment into and out of the shop. A sufficient number of tracks extend through the rear wall of the building to facilitate the movement of material into the shop.

from the pattern storage. The general construction of the building is the same as that of the other buildings, the roof being of slow burning mill construction. The structure is 162 ft. long by 31 ft. wide and is heated by direct system and lighted with keyless socket marine type incandescent lamps. A sprinkler system is provided for fire protection.

Foundry.

The grey iron foundry building is 203 ft. long by 80 ft. wide, constructed with two bays. The frame is of structural steel carried on concrete footings. The general construction is the same as that described for the other buildings except that the floor is of the usual clay type used in foundries; the roof over the cupola room is of corrugated asbestos.

The bay of higher cross-section is served over its entire length by a 10-ton high-speed travelling electric crane. Jib cranes, attached to building columns are provided, and are so arranged that they may be removed from one location to another if desired, being handled by the

traveling electric crane. In the side bay of lower cross-section space is provided entire length by a 10-ton high-speed traveling electric crane. In the side bay of lower cross-section space is provided for core making and shop moulding floor. The charging floor for the cupola is located in the centre of the lower bay.

Heating is by the indirect fan system with underground tile and concrete hot-air ducts. For general illumination, flaming arcs are used in the high bay and ordinary arcs in the low bay, with outlet boxes for extension lamp cords. Toilets, lavatories, and conveniences for the men are provided; also steam, air, and water service, for fire protection and drinking purposes.

The location of this building alongside of and parallel to the travelling electric yard crane enables the unloading of scrap and pig-iron to be taken care of

The offices are heated by direct radiation the remainder of the building being heated by the indirect system. The lighting is by incandescent lamps and fire protection is by automatic sprinklers. The ground floor of the storehouse has $\frac{1}{2}$ in. asphalt mastic surface, while the other floors throughout the building are of wood. The window arrangement is such as to best accommodate the material bins and shelves without interference with good lighting.

The storehouse is located parallel with the main locomotive shop, the space between these two buildings being spanned by a high speed travelling crane which can be utilized to handle all heavy material to and from the cars from the storage space provided between the storehouse and the erecting shop. The use of this crane practically eliminates manual handling of heavy material, and permits of handling numerous small

distribution. The roof is of reinforced concrete slab, as is also the floor of the pump room over the basement. That part of the building used for storing oil in barrels has a cinder floor. The pump room is partitioned off with a brick wall carried up to make a fire wall.

Ten oil tanks with measuring pumps are installed and provision is made for conveniently emptying the oil from barrels into tanks in the basement. The oil house basement is heated by the direct system, to the high temperature necessary to render the oil fluid during extremely cold weather. The direct system being also used to heat the rest of the building. The lighting of the building is by keyless socket marine type incandescent lamps. Fire protection, including sprinklers, is installed.

Coach Repair and Paint Shop.

The building containing these departments is 362 feet long by 146 feet wide, having 15 tracks on 24 ft. centres. It is constructed with hollow building tile carried on concrete foundations. Heavy timber posts support the roof which is of slow burning mill construction. Otherwise, the construction is the same as that described for the main shop building. Space is provided along one side of the building for varnish room, upholstering, office, sub-store, paint storage, heating plant and air brake repairs. When necessity arises for increased shop capacity in this department, it is proposed to obtain such increase by the erection of another shop on the opposite side of the transfer table.

Heating is by the indirect fan system with underground concrete and tile ducts while lighting is by incandescent lamps, Compressed air, steam and water services, including fire protection and automatic sprinklers are provided. Toilets, lavatories, and conveniences for men are also fitted in this shop.

Freight Car Repair Shop.

The freight car repair shop is 231 ft. wide by 303 ft. long, and contains 8 repair tracks, spaced in pairs with industrial track between each pair of repair tracks. A tile wall partitions off the shop, 50 feet wide along one side, which will contain the blacksmiths forges, tools, heating plant, foreman's office, toilets and lavatories.

The building is of structural steel frame with tile walls, plastered on the outside, and of sawtooth roof construction. The general construction, otherwise, is the same as that of the other shop buildings. An overhead trolley beam is provided to permit of handling timbers with a trolley into the shop. Compressed air, steam and water service piping, and fire protection, including automatic sprinklers, are supplied.



NORTH-WEST VIEW SHOWING ROOF ARRANGEMENTS WITH REFERENCE TO LIGHTING OF ERECTING AND MACHINE SHOPS.

by the yard crane also reduces to a minimum the handling of the castings from the foundry to storage, to the main shop, or in loading for shipment.

Storehouse and Office Building.

This building is 252 ft. 6 in. long by 60 ft. wide. One end of the building for a length of 40 feet is carried up three stories, and contains offices on the second and third floors, and a fire-proof vault. The remainder of the building, for storehouse purposes, is two stories high, and contains electric elevator, platform scales, material bins and shelving. The walls are constructed of hollow-tile blocks on concrete foundations; the framing being of heavy timbers, with roof sheathing of two by four's surfaced on one side and one edge, and spiked together on edge. The foundations are carried up to bring the floor of the storeroom to ear door height. The necessary toilet and lavatory facilities are provided.

parts in quantities, when contained in suitable receptacles.

Material Platforms and Scrap Dock.

A material platform 90 ft. wide and about 350 ft. long, abuts one end of the storehouse. This platform is also carried along either side of the storehouse where it is 15 feet wide. It is constructed of concrete retaining walls filled in with earth, and a top dressing of cinders covers the fill except along-side of the storehouse, where plank covering is laid. The platform extends to and along the sides of the oil house.

Oil House.

For storing and distributing oil, a separate building is provided convenient to, but located far enough away from the storehouse and other buildings to eliminate the fire risk. It is constructed with tile walls (plastered on the exterior), on concrete foundations, with a concrete basement at one end for the tanks which contain the oil for local

Heating is by the indirect fan system with underground concrete and tile ducts while lighting is by 100-watt tungsten lamps. The location of this building alongside of the lumber yard permits of handling lumber so that it can be passed through into the shop without rehandling.

Planing Mill.

This building is 303 ft. long by 80 ft. wide, and contains the wood-working machinery. The frame is of structural steel carried on concrete footings. The general construction of the building is the same as that of the other shop buildings. A track extends through the building longitudinally to permit of movement of material inward at one end to the various machines, and out through the opposite end with the minimum amount of handling. The building is located so as to be convenient to the

The overhead coal bunker for each boiler is divided by a reinforced concrete partition into two compartments, to provide for storing and burning two kinds of coal. An overhead storage bin for ashes is provided, from which the cinders can be discharged by gravity into cars alongside the building. A concrete dumping hopper is provided outside for dumping coal from cars. A pivot steel elevator raises and discharges the coal into the overhead bunker. A skip-bucket with electric hoist handles the ashes into the ash bin.

The boiler units are of 350 horsepower rating, and are set in three batteries of two each. Five of the boilers are equipped with chain grate stokers. The sixth boiler has shaking grates for burning shavings and other planing mill refuse.

Space is also provided for three elec-

motives shop and carries a 10-ton high-speed traveling electric crane with 80 foot span, serving the material yard and a portion of the store house platform and scrap dock. One of the storehouse tracks extends through under this crane resulting in ample space being given for the storage of material alongside of the storehouse, foundry and locomotive shop. By this arrangement, heavy material can be unloaded, stored, and rehandled to the shop or loaded out again by the crane for shipment, practically eliminating manual labor in the handling of all heavy materials.

Miscellaneous Structures.

The transfer table for serving the coach shop is 75 feet long, and of 150 tons capacity. It is equipped with electric motor, and with concrete transfer table pit 400 feet long, extending out far enough at either end of the building to provide entrance and egress at both ends.

The mess building, 269 feet 6 inches long by 31 feet 10 inches wide, is of wooden frame construction, covered outside with sheathing, building paper and siding, and sealed on the inside with metal sheathing. It has a concrete floor, and contains a dining room for the officials, together with kitchen and pantry. Sixty feet of the length of the building is carried up two stories to provide an apprentice school-room and quarters for the help. Heating is by the direct system, and lighting by incandescent lamps. There are also two small buildings located near the freight repair tracks for blacksmith shops and workmen's tools, and in one of them is a small toilet and office. Dry kiln, material bins, plate and iron racks, coal and coke sheds are also provided.

For obtaining water for shop purposes, there have been put down two 8 inch wells, equipped with electrically operated pumps. To supplement this supply, and to provide a main source of supply for fire protection, the City of Calgary has brought down into the shop site, to a point midway the length of the main shop building on the west side, a 10 inch cast iron water main. The shop service and fire lines are connected on to this main, and into a steel tank of 125,000 gallons capacity, which is erected on a 70 ft. steel tower, principally for use in connection with automatic sprinklers in the various buildings where these are installed. A complete fire protection system has been put in with hydrants distributed about the shop yard.

The sewage system in the shop yard may be divided into the sanitary and storm sewers. The City of Calgary is furnishing the main sanitary sewer, beginning at the east line of the freight car shop and extending to the eastern bound-



COACH REPAIR SHOP.

passenger and freight car shops. The lumber yard is located back of, and at one end of the planing mill.

Suitable piping has been provided for distributing compressed air and water, and the fire protection system includes automatic sprinklers. Provision is made for toilets, lavatories, and metal lockers for the men employed in this department, while heating is by the indirect fan system with galvanized iron heating ducts. Lighting is by mercury vapor lamps.

Power House.

The power house contains sufficient space for 2,100 horse-power water tube boilers required to provide steam for heating the shops and for other purposes for which steam is required. The building is constructed with brick walls carried on concrete foundations, with steel roof trusses and supports for coal bunkers. The chimney is of reinforced concrete, 200 ft. high, with a minimum diameter of 9 feet.

Electrically driven air compressors each of a capacity of 1,500 cubic feet of free air per minute, only two of these being meantime installed. Transformers and distributing panel are located in this building for transforming and distributing light and power current to the shop yard, freight car shop, planing mill, and coach repair shop. There is no direct current apparatus in this station. Provision has been made for two incoming 2,200-volt lines, one of 2,000 k.w. and the other of 1,000 k.w. capacity for breakdown service.

The steam required for the steam hammers and other shop purposes during the summer time can be supplied by one boiler. The boiler capacity provided will afford one spare boiler during extreme weather conditions when the maximum steam demand occurs.

Yard Crane.

A yard crane runway, 1260 feet long, extends from the west line of the loco-

dary of the shop property. All the sanitary sewage lines from the various buildings are connected into this sewer. Storm sewers are provided where necessary to carry off the roof water from the buildings where the roof construction is such that this cannot be discharged on to the ground.

The Work of Construction.

The location of the shops is about four and one-half miles east of Calgary, practically on the open prairie, and at the beginning of construction, arrangements had to be made to house and board on the shop property a considerable quantity of labor. To this end, frame bunk houses were built with two tiers of bunks on each side of the building, eight bunks long, each house having a capacity of 32 men. Stoves were placed in the centre aisle and benches along the sides of the lower tier of bunks. On the coming of summer, and as the labor forces were increased, some of the men were housed in standard 12 x 14 wall tents which accommodated four men each. A large mess room and kitchen and storeroom space were also fitted up with a capacity for feeding about 400 men at one time.

Great care was exercised in keeping the camp in a sanitary condition. This work was largely under the direction of doctors who visited each day to take care of possible sickness, and an arrangement was also made, whereby those who were employed on the work voluntarily contributed a small amount from their wages for the services of these doctors. This amount also included hospital service when necessary. Due to this care, there was very little sickness on the job.

As there was no accommodation for men with families near the shops, the Railroad Co. put into temporary service a train to carry the men back and forth from Calgary, and several hundred men went back and forth on this train each day. This arrangement helped the situation considerably, especially as the season advanced, and all kinds of skilled and unskilled labor became more difficult to obtain. A standing order was placed through several labor agencies in Calgary to send men daily to the job. As the work neared completion, the bunk houses and mess house previously mentioned were turned over to the railroad to take care of their own men, who were at that time living on cars on the property. This, of course, released the cars and permitted their use at other points.

The progress schedule will show the prosecution of the work, but it should be again pointed out that it was not possible to break ground until April 1st, 1912, and by March 17th, 1913, the loco-

motive shop was in full operation. When the magnitude of the work is considered as also its distance from the larger centres, it will be appreciated that a record for prompt performance has been established.



WELDING: ELECTRIC AND OXY-ACETYLENE.

THE Marine Department of the Board of Trade has now, after trial, approved the electric and oxy-acetylene processes for repairs to boilers of passenger steamships. The recent instructions to surveyors state that, provided the work is carried out to their satisfaction by experienced workmen, these processes may be employed, within limits, for repairing cracks in furnaces, combustion chambers and end plates, and in the same parts for reinforcing the landing edges of leaky riveted seams which have become reduced by repeated chipping and caulking. Repairs to any parts of boilers which are wholly in tension under working conditions, such as cylindrical shell plates and stays, are not, however, allowed by these processes.

It is noted that in some old furnaces repaired by the above processes it has been found that, after a few months' working, cracks again developed at parts near to those welded, probably owing to the material of the furnace having become fatigued and worn by long and severe usage. When dealing with old furnaces this fact should be considered. In proposed repairs of an uncommon or unusually extensive character the particulars should be submitted for the Board's approval.

After repairs by welding have been completed, the parts at or near the welds should be hammer-tested, and a hydraulic test of not less than one and a half times the working pressure should, as a rule, be applied to the boiler after the hammer-testing.



STANDARDIZATION OF ELECTRICAL MACHINERY.

WRITING in the columns of Vulcan on "The Standardization of Electrical Machinery," Mr. G. W. Worrall points out that when an individual drive of each machine in a shop is required it is sometimes necessary to install some motors of a greater power than is actually required in order to keep the variety of motor sizes within the required limits. When, however, an individual drive is not necessary, the driven machines may frequently be so grouped as to take a given power. One of the best examples of an individual drive is a carpenter's shop, where each

machine requires a motor of only a few horse-power. Some sacrifice must in such a case be made for the sake of standardization.

A case of such a shop came recently before the notice of the writer, when at a little extra cost, excellent standardization might have been effected, but where for the sake of cheapness motors had been installed of the exact power required. There were nine motors in all, two 20 horse-power at 900 revolutions, one 6½ horse-power at 875 revolutions, one 5 horse-power at 1,150 revolutions, three 3½ horse-power at 1,400 revolutions, one 2½ horse-power at 1,150 revolutions, three 3½ horse-power at 1,400 revolutions, one 2½ horse-power at 1,150 revolutions, and one 2 horse-power at 1,200 revolutions. The motors should have been divided into three groups; two 20 horse-power at 900 revolutions, two 6½ horse-power at 1,000 revolutions, and five 3½ horse-power at 1,200 revolutions. One spare armature for each group would have rendered the shop practically immune from any serious stoppage.



U.S. STEEL CORPORATION IN CANADA.

JAMES A. Farrell, president of the United States Steel Corporation in testifying as to the corporation's export trade in the United States Government suit, referred to the Canadian business in part as follows:—

"Through Montreal we sell in Canada about 60,000 tons of wire product a year, sheet iron, mine rails, and sometimes standard rails, when they cannot be supplied by their own corporations. We are now supplying the Canadian Northern Railway with 25,000 tons of rails shipped by boat from Chicago and thence by rail to Calgary, where they cost \$47.13, delivered.

"At Vancouver we supply much material, but the freight rate from Pittsburgh there is \$18 a ton. Material from Liverpool or Antwerp may be shipped for \$6 or \$8 a ton. After we established our office there we found it necessary to run a steamship service. Our ships leave about every two months, making stops all along the line. On the return journey, we go into a general merchandising business."



Sault Ste. Marie, Ont.—Dr. Casoratty, the financier who controls the dry dock and shipping franchise was in the city recently, and held a conference with members of the firm who will build the plant. It is believed that work will go ahead in the near future.

The Layout, Design and Equipment of Industrial Works*

By A. Home Morton, M. Inst. C.E.

The author of this paper directs attention to the want of thought which has, in the past, been given to the true and proper design of industrial works in Great Britain, and cites Germany and the United States as countries where due regard is paid this feature. There is much in the paper to claim perusal, and careful study by readers of Canadian Machinery.

INDUSTRIAL works design is a special branch of applied engineering. It is not merely the design of the structure, of the power plant, or of the works equipment; it is all of these and more. It is the correct co-relation of the human mechanical, and final equipment of an industrial undertaking, and involves consideration of every problem which may arise from the conception to the realisation of the scheme. No one is better fitted to study these than the engineer. A sound technical training combined with a keen insight into international industrial movements and the faculty of observation, are his basis qualifications.

The Industrial Engineer.

Industrial engineers may be either professional designers, serving directly the interests of their clients, the principals in the scheme, or manufacturing designers selling their experience and manufactures to those principals. In either case the energies of the engineer-designer are essential to the birth of every industry, and his services to its continued progress. It is but reasonable, then, to expect that the creation of a new industry, or the re-organization of one already existing, ought to be first of all committed to the experience of an engineer-designer, either professional or manufacturing, and certain that command of this experience, when available prior to the inauguration of the industry, is of value infinitely beyond its cost. It is beyond doubt, also, that these services must be paid for whether obtained from a manufacturing designer, or from a professional designer.

Present Day in England.

The blunder which is perpetrated on all hands in England to-day, is the creation of industrial works, and the birth of industries without adequate time having been spent upon their real design. Buildings are erected by competent designers of buildings per se without sufficient consideration of the purpose for which they are to be used, and an industry is launched and housed in these unsuitable buildings, amid less suitable surroundings, only to find, when too late, the enormous handicap under which it must labor. In Germany this

*From a paper read recently before the Liverpool Engineering Society.

state of affairs has long since ceased to be. In both these countries, industries are being truly designed, not works merely built and started. Fortunately a similar attitude to industrial design is gradually being adopted in Great Britain, but things are still a long way from the ideal.

Division of the Subject.

The subject may be divided into six sections, and it will be obvious that it is only possible in a paper of reasonable length to consider these sections in a special and limited manner.

- (1)—General and financial considerations.
- (2)—Labor and labor conditions.
- (3)—General arrangements.
- (4)—Generation and transmission of energy.
- (5)—Design and consideration of the works structure.
- (6)—Reconstruction.

1—General Considerations.

The stress of competition in modern industry demands efficiency with economy in every department. Industrial engineer-designers are, in consequence, frequently called upon to supplement estimates of the capital cost of a projected undertaking with estimates of the working costs, maintenance, and even of profits.

These demands in proprietors' interests, are, under certain conditions, legitimate and desirable, and the engineer-designer must be able to satisfy the proprietor with such estimates, accurate to within a moderate percentage. Careless estimating ought to be inconsistent with professional honour.

No practice is more to be condemned than that of encouraging proprietors to launch a scheme upon ill-considered and illusive estimates. This is only one degree more reprehensible than the policy of launching schemes under the auspices of some financial house without reference to works design, capacity, or success, and with a large share of the capital set aside to cover some vending company, suitable or unsuitable land or buildings, doubtful patent rights, and similar tangible and intangible assets. An industrial undertaking is essentially an investment in which it is proposed to sink capital, perhaps the savings of private individuals, or, it may be, public moneys. Nothing then, ought to be

permitted, either in the initial financial arrangements, or in the design of the scheme, which may, in the slightest degree, handicap its future chances of success.

A leading designer has said that, in industrial design, "fads and frills" are alike intolerable. Certainly, an industrial undertaking is not meant to exploit the foibles of its designer, nor to enrich a vending company at the expense of the public.

Marketing a Profitable Outfit.

The first consideration should not be what capital can be secured, but what immediate output can be profitably marketed. This question ought to be the subject of much careful consideration on the part of those into whose hands the future working and success of the business is to be entrusted. The initial output required having been determined, the data ought to pass into the Engineer-designer's hands to be worked up, and, in due course, be presented as a completely designed scheme for consideration by proprietors and their managers. From this design, embodying the works buildings, the works equipment, the power plant, and the area of site necessary, the several sectional costs and the probable total capital cost, can be determined to within a small percentage of probable error.

From these preliminary figures, the capital sum to be set aside for the works site can be estimated and available sites considered. It is desirable that these sites should be examined, surveyed and opened up, if need be, to ascertain the character of the sub-soil, and to determine their outstanding peculiarities. Rough block plans of the works should also be laid down upon the plans of the likely sites, and their merits and demerits should form the subject of a preliminary report, with special reference in each case as to:—

- (1)—Advisability of labor, of raw material, and accessibility to markets.
- (2)—Water, fuel, and other works supplies.
- (3)—Areas for storage, refuse dumping, and particularly extension.
- (4)—Probable ground charges, rates and taxes.

To overlook any of these factors may prove a serious handicap to the future of the industry.

From these considerations, it should be possible to fix upon the most convenient site, and immediately thereafter to form a close estimate of all costs, and draw down a complete general arrangement plan of the future works. This general arrangement may later be modified in detail, but it ought to be so complete and so carefully prepared that proprietors and their officials will be clear as to their liabilities and the works arrangement before a penny has been spent on permanent works.

II—Labor and Labor Conditions.

Due consideration of and for the worker is now being accepted as a sound business policy rather than as a mere economic idea or fad. The law of the land is becoming more stringent in its demands for the health and convenience of the workers. There is a tendency towards improved labor conditions and the reduction of physical drudgery by the introduction of aids to labor. A certain school of economics does contend that the increase of mechanical appliances tends to lower the standard of excellence and skill in handiwork, and, consequently, the intelligence of the craftsman. This may be, in part, admitted, but it is equally true that the greater perfection of result, increased rate of production, and usually greater reward which result from mechanically aided labor, do tend to improve labor conditions, and to uplift, rather than to degrade, the worker.

It must be clear that in order to secure not only quantity, but quality of output, the interest and skill of the worker and the perfection of equipment must be alike maintained unimpaired. In engineering works, where modern methods hold, experts are employed who devote their energies to the regulation of the feed and speed of the high-class tools now generally in use, yet there is far too frequently in parallel with these efforts a marked lack of attention to the conditions of labor. Apathy among a body of workers, whether due to physical or mental depression, in consequence of unsatisfactory conditions, or discontent from any cause, may easily prove a far more serious loss to the management than even inefficient mechanism. Industrial efficiency cannot be expected unless the human and mechanical factors in the works equipment have both their maximum value. It is most important, therefore, that the labor conditions should receive attention equal at least to that bestowed upon plant and equipment.

There are very few ideal works in existence in Great Britain, but where these have been established, the economy and soundness of the investment has been almost universally demonstrated. Industries, established under ideal con-

ditions, have come to grief, it is true, but not owing to the ideal conditions.

Consideration for the workers does not involve extravagance either in design or equipment, and, when judiciously carried out, yields a fair return.

Site and Environment.

The site and environment of the works have also a marked effect upon the workers. Physical fitness can be more easily secured and maintained amid congenial surroundings. Thus with the means of internal communication available to-day, the transference of great industries to suburban or country sites has very much to commend it.

Legitimate conclusions would therefore be that, if an industrial undertaking is to take its proper place in the international competition of to-day, it must be the subject of careful preliminary consideration, so that it may finally take shape as a well designed and well equipped works, complete with all necessary plant and fittings, properly situated in regard to its raw material and market, having a sound commercial organization and management, and provision for the health, comfort, content, and even education of its workers. Under these conditions it may be expected that there will be willing co-operation between employer and employee, and, if the existence of the industry can be justified at all, financial success.

III—General Arrangement.

It is necessary next to consider more directly the works themselves. Successful general arrangement of industrial works pre-supposes practical acquaintance with the manufacturing process, and with the works plant. This essential knowledge, if lacking, may readily be secured by the engineer-designer by careful study of similar works, or through the technical press. With this knowledge and his own special training, the engineer-designer should be able to build the works on paper and to see them in his mind's eye with every stage of the process in operation before the ground is broken.

It is also essential that the design of the buildings, the steel structure, the power plant and transmission, and the arrangement of the process plant should proceed simultaneously. Indeed, in the case of the two latter sections, it is essential that they should be considered in parallel. It is quite a common practice to have these separate sections designed by separate people and assembled under the supervision of the principals and their officials, but it seems almost needless to urge the advantage which must accrue if these can all be carried through under the direct supervision of one individual.

When the general arrangement of

works departments is approached in the abstract, it is somewhat difficult to treat it profitably. There are factors which have a direct influence upon all works arrangements, and are almost axioms, but nothing can be so satisfactory as a concrete example. With such an example, the arrangements could be considered with direct reference to all the factors bearing upon them. It will probably be more profitable, then, as a compromise, to refer briefly to the general influences affecting the works' general arrangement, and later to show some plans of actual works.

Influences Affecting Works General Arrangement.

A works' general arrangement must be considered, first, with reference to the character and quantity of the output, and the limitations and disabilities of the site. Actual works designed to produce the same commodity on sites of varying form are found on examination to have similar essential areas, even although they may differ somewhat in arrangement. This suggests a relationship between floor area and output, which, theoretically ought to hold, and which, on investigation, will be found to hold even in works which have grown from humble beginnings. Such a ratio of floor area to output will vary with the magnitude of the output, although it will probably hold for average conditions over a considerable range in magnitude.

To illustrate what is meant, the average percentage floor space in each department of four engineering works producing a similar commodity and in approximately equal quantities was noted to vary between $\frac{1}{4}$ per cent. and 3 per cent. as between the maximum and minimum percentages for each department. This gives to the designer what may be called an approximate formula for departmental areas in such works. In a similar manner, areas for yards, storage and refuse, can each be reduced to fairly correct relative values. These areas should, of course, be ratios of the total site, although only that portion of these areas required for the immediate output should form the works proper initially, the remaining area being left for extension. Works are meant to succeed. Success demands extension, therefore a well arranged scheme of extension should form part of every original design.

The development of the general arrangement can now be entered upon. The first essential to a general arrangement design is the "process diagram" and the second the "routine diagram."

The Process Diagram.

To those who may not have come in contact with these diagrams, a brief ex-

planation may be of service. The "process diagram" is simply the enumeration in tabular form, or the graphical presentment of the several works process. For example, in paper mills, the several processes are—sorting and cutting, dusting, washing, breaking, bleaching, beating, coloring, paper making, drying, sizing, and glazing; in the manufacture of cotton—bale-opening, mixing, cotton-opening, scutching, carding, drawing, lapping, combing, slubbing, roving, mule and ring spinning, doubling, twisting, winding, gasing, reeling, bundling, tying, pirn winding, warping, and weaving. When to a graphical diagram of a process of manufacture is added a complete schedule of the areas required to house the machines necessary to produce a given output, then a complete "process diagram" is the result.

From the process diagram and the basis areas already mentioned, the engineer-designer, with an intimate knowledge of the whole process of manufacture, and of the machines necessary to accomplish the process in each particular section, may proceed to prepare the "routine diagram."

The Routine Diagram.

The routine diagram represents graphically the flow of work in process. In preparing this, the following axioms should be kept clearly in view. Works should be so arranged that the material dealt with and manufactured shall flow through them in an orderly manner, in one direction, as far as may be, and without waste of time, energy or material.

The routine diagram is probably the most difficult part of works design. It involves the sequential arrangement of the machines within each department, and thereafter the laying out of the departments relative to each other. To carry this out successfully requires great skill and care, and probably much tactful discussion with the proprietors, managers, and foremen of the proposed works. From the detail data available, however, suitable approximate linear dimensions and heights for buildings may be fixed, and thereafter the manipulation of these blocks may proceed until the most satisfactory relative positions of departments are secured.

The routine diagram is complete when the several departments are arranged on paper, and the flow of work in progress through the departments is as nearly as possible perfect. The first design is rarely final. A large number of block plans, each having advantages, may require to be prepared before even a measure of satisfaction is reached, and the final plan is usually an amalgam of the leading features of several of the draft plans.

It may be said that this work could be done by the works proprietors or managers. Experience shows, however, that a good manager is not necessarily a good designer of works, even for his own trade. Every man works most efficiently when on the work for which he has been trained. Better then for the manager to take time from his own work only to point out briefly his requirements and the peculiarities of the trade or process to the engineer, leaving him to meet the requirements and solve the problems. There can be no doubt that an engineer-designer, skilled in this particular class of design, can, with very beneficial results, bring a fresh mind to problems, the solution of which may have become stereotyped, and import useful ideas from other trades which have come under his wider range of practice. It must also be borne in mind that the problem of the works power plant and power transmission can best be considered closely in parallel with the works design.

Power Transmission Feature.

It cannot be too well remembered that the works building should accommodate the plant, that the process of manufacture should not require to accommodate itself to the buildings, and that the transmission of power, like a great arterial system, conveying life to every department, is an integral part of the scheme, and must be considered from that standpoint. If this be not done, then it may be that, instead of being so compactly arranged as to permit of direct driving by means of a single steam or gas engine, the works arrangement may be such that only electrical transmission (frequently misused to cover bad design), can be satisfactorily applied. The requirements of the power transmission system may sometimes modify the general arrangement, but in most cases, the method of power transmission will be fixed by the requirements of the general arrangement.

Other Important Factors.

Other important factors bearing upon the general arrangement of a works or factory are railway communication lines, internal transport of materials, and general auxiliary equipment. The railway communication lines should be simple and economical in arrangement and at the same time adequately serve each department, provide suitable sidings, package, and storage lines, and yet maintain adequate through communication to all departments.

Entrance siding lines should, wherever possible, permit of the passage of a main line goods locomotive to the more important section of the works, and where this is impracticable, ordin-

ary waggon sidings, served by a pug engine, having a short wheel base may be accepted. The means of internal transport may be by traveling cranes, power runways, hand runways, or bogie trucks, with or without tracks. All have their particular spheres of usefulness, and care bestowed upon their selection and installation is of value, since they are among the more important labor-saving appliances within a works. External transport, other than by railway lines, may be by overhead traveling cranes upon gantries, by traveling gantry cranes upon railway tracks, by loco jib cranes, by power runways or by cableways.

Auxiliary Equipment.

In addition, there is a large assortment of what may be termed "auxiliary equipment" in a large works, which falls to be considered in parallel with the works' arrangement, such as water supply from bore well, river or local system, with probable treatment plant and filtration for works and boiler service and for drinking purposes; fire service, usually an independent ring water service, probably inter-connected with some fire appliance of the sprinkler type; drainage divided into two sections, foul drainage direct to the local sewage system or to an independent treatment plant, and surface water, if pure, directly connected with the condensing plant and cooling pond; lighting, by electricity, high-pressure gas or oil gas; repair shops and tool rooms, stores, offices, and men's rooms, and many other minor departments.

IV.—Power Generation and Transmission.

The subject of power generation and transmission in industrial works has been frequently and exhaustively treated in recent years. The proceedings of the several technical institutions contain data to which ready access may be obtained. On the other hand, the mass of information there available is so technical, so varying, and so conflicting in its conclusions as to be, in great measure, beyond the grasp of most power users.

Tests have been made and comparisons drawn to prove the superior economy of practically every type of power plant and every transmission system, and it is true that after a full and impartial consideration of the relative merits of the three more important transmission systems, with reference to a particular works, it may be necessary to admit that each of them has some superior merits.

An interesting side issue bearing directly upon this question may be noted. The shop costs in a number of manufacturing establishments in the engineering and allied industries have been analyzed, with the result that the cost

for power is shown to be only from 2 per cent. to 5 per cent. of the total cost of manufacture. This is a most important point. In other industries the ratio of the cost of power may be much greater or even less, but, in certain manufacturing establishments, a quite legitimate conclusion may be that the influence of power costs upon manufacturing costs is so trifling as to be nearly negligible. The narrow margin may on the other hand mean all that there is between profit and loss to the manufacturer. These facts lend weight to the statement so frequently made, that reliability, flexibility, and adaptability to the needs of the worker are more to be sought after in a transmission system than simply economy of operation. It is certainly true that a very modest reduction in the labor costs in most works, due to increased manufacturing facilities may represent a handsome percentage, if not the whole, of the cost for power. The expansion which has taken place in the applications of electricity in industrial works has further proved that this aspect of the case exercises an important influence on the minds of manufacturers. There are many electrical installations which could hardly be justified on any other grounds.

Power From Waste Products.

Certain manufacturing processes have features which have a direct bearing upon the question of power generation and transmission. Iron and steel works have so-called "waste gas" and "waste heat" from which power may be obtained: collieries large quantities of low grade fuel and filtered washery liquor or coke oven gas; saw-mills, carriage and wagon works, a certain quantity of timber refuse; exhaust steam from smithy hammers; while in other classes of factories, bleach and dye works, chemical works, sugar works, etc., the demand for steam for the manufacturing process may exceed the demand for steam for power. A decision, therefore, on this question of power generation and transmission demands the consideration of all the several forms of generator and motor before any conclusion can be come to, as well as of all the features and possibilities of the works themselves, and further, this consideration of the question must be impartial.

To compare an antiquated steam-driven shafting system, which has just been superseded, with a high-class gas-driven system, which has just been installed, is only of value in that it indicates the saving effected by the introduction of modern power plant. A few years ago there was a boom in gas engine plants, and gas engines were placed in scores of works after only the minimum of consideration of the works' re-

quirements. To-day, the traveler for gas engines has given place to the traveler for electric motors, and there is a boom in the installation of electric motors, in many cases with as little consideration as in the case of the gas engine.

The author ventures to say that nothing could be more prejudicial to the best interests of the electrical industry, an industry in which all are intensely interested, than the thoughtless manner in which electricity is often adopted for industries where even brief impartial consideration would raise doubt as to its entire suitability. Partisan figures and statements are presented to probable purchasers, and they are thereby led to adopt plants through having been unable to discriminate between what was reliable and what was misleading.

Each System Has Its Advantages.

The following general statements may not be new, but they form an essential part of the subject and cannot be ignored. Like all generalisations, they are subject to modification under particular circumstances.

The first conclusion, and that to which it is difficult to reconcile the partisan mind, is that each system of power generation and transmission has its particular advantages and superior economy, and that maximum economy in works driving in a particular case may be obtained by a combination of two or more systems. The difficulty is usually not so much the selection of the system as the determination of the extent to which it should be utilized.

Dealing first with transmission systems. Where the plant is compact and conveniently arranged within a radius of, say, 100 or 150 ft. from the central power plant, mechanical transmission is most economical, while, with an increased radius, gas or electrical transmission has advantages, the former being the most enticing system from the point of view of thermal efficiency, but meantime having a more limited application. From this it follows that, in small works and factories, the most careful thought ought to be given to the works design in order to ensure a compact arrangement and efficient mechanical transmission.

Where tools are set widely apart, electrical transmission with independent motors is economical, although where it is possible to have a group of tools in a works, an independent gas engine or electric motor driving these through gearing is more economical than independent motors.

Where the amount of power required for individual machines is small, it is almost always advisable to group them. That this conclusion is borne out in practice will be seen by examining the

published descriptions of the electrification of several large engineering and shipbuilding establishments. From these descriptions it will be found that the average size of motor is steadily rising.

The question of reliability and consequent need for stand-by plant is also important. Practically any one of the systems, if properly installed, can be regarded as reliable, but the subdivision secured by the use of motors or small gas engines has advantages.

The chief advantages of the electrical transmission system are its adaptability and the ease with which it can be extended, and its chief drawback is its cost, a part of which, at least, is due to the refinements which have been introduced into electrical controlling and operating mechanism.

Merits of Electrical Transmission Systems.

Before passing from the question of the transmission system, a word or two might be interesting upon the merits of the rival electrical transmission systems. It is probably largely a matter of opinion whether a direct current or a three-phase alternating current transmission system is more desirable.

The question of power generation, like the question of transmission, depends for its solution upon the conditions of service. Where the power demand is very intermittent, purchased electrical energy has advantages over all other systems, although for dock pumping, slipway haulage, and other heavy intermittent loads, gas engines, using town's gas, are very economical in use. For a moderately steady demand up to about 100 to 150 b.h.p., the suction gas engine has no rival. Above this load it is possible to purchase steam plants using highly superheated steam, which can generate one i.h.p. per hour, at a fuel cost of little over 1 lb., and a steam cost of approximately 8½ lbs. Such a plant is, however, uncommon, and until it becomes more general, the range of usefulness of the suction gas engine may be said to rise 150 to 200 b.h.p. Above this limit a steam plant using low grade fuel has advantages which have been greatly enhanced by the recent advance in the price of anthracite. Indeed, the position of the steam engine or turbine of single unit plants of over 200 b.h.p. is not even today seriously assailed, except where the main question is complicated by side issues, or where the cost of coal is well above the average, the advent of the geared turbine being a most interesting and pregnant development.

Where an electrical transmission system has been decided upon, the purchase of current demands first and most careful consideration. If a private plant

is decided upon, then the generators may be either steam or gas engine driven. The units, in the case of gas engine driven generators, may be of practically any size desired, while steam engine driven units may be reciprocating engines up to 750 kilowatts, and steam turbines thereafter. Interesting results can be got from the combination of reciprocating engines with steam turbines, a combination of this character giving a wide range of economical load at a modest capital cost, this advantage being obtained by cutting out the turbine from the lower loads and exhausting direct from the reciprocating sets to the condensers.

The sphere of usefulness of the large power gas engine is confined mainly to situations where so-called waste gas can be obtained, as at coke ovens and blast furnaces, or where chemical plant already is installed. Ironmasters are unfortunately even now by no means unanimous in their desires for these generators. There cannot be any doubt, however, that where waste gas is available, the large power gas engine is in many ways desirable.

The side issues in works power plant also require consideration. The utilization of exhaust steam in turbines, from blast furnaces, and coke oven gas in large power gas engines, and the development of the storage battery in connection with the fluctuating loads in large works, are all problems of remarkable interest, but time does not permit of anything like consideration of these, nor does the title of this paper seek to cover them.

V.—Design and Construction of the Works Structure.

It might be argued that the design of the works structure—that is, of the buildings and sheds, should be left in the hands of an architect. "Architect" as here has its modern and limited meaning. There is, however, nothing in either simple brick filling, in the steel structures which are usual in industrial works, or even in simple factory buildings, by means of which the artistic temperament of the architect can find adequate expression, and his efforts would of necessity be hampered by being subject to the limitations imposed by the engineer-designer in respect of the works plant and arrangement, assuming, of course, that the works are really being designed to house a manufacturing process, and not that a manufacturing process is later and somehow to be housed in certain buildings.

Works buildings are designed in the first place to withstand the special stresses to which they will be subjected in service, and effectively and economically house the machinery and power transmission plant. Detail consideration

of these matters does not enter into the architect's training. For this reason the design of industrial works and factories, in all its details, ought to be left to the engineer-designer with the proviso that he is not at liberty to perpetuate an offence to the public eye.

The essential feature of all industrial design should be simplicity, utility, and efficiency, combined with low first cost and durability. These features should be apparent, whether in the design of the power plant, of the electrical installation, or of the structure. The simplest manufactured details readily procurable from stock ought to be used for all details, unless these are quite unsuited to the purpose of the designer. Steel structural work, even more than builders' work, ought to be characterized by simplicity and well-placed material. Artistic or eye-pleasing effect can always be obtained by correct design, carried out in suitable materials on well balanced and simple lines, carefully arranged and well-proportioned, without useless and meaningless ornamentation. Nothing can be truly artistic or eye-pleasing which violates the principles of design, or misuses material.

Character of Industrial Structures Changed.

The whole character of industrial structures has changed to a marked degree in recent years. Formerly, works had massive stone walls and timber roofs. To-day the steel structure has displaced the older materials almost completely. In factory construction, reinforced concrete is coming more into use, and some very beautiful structures have been erected in reinforced concrete with brick filling, this class of construction, especially where brickwork is also reinforced, is particularly satisfactory.

The question of economy in first cost may have greater influence on the class of construction than is warranted, and may lead to the adoption of timber. The cost of maintenance and the fire risk with the ordinary form of timber construction, combined with the relatively shorter life, are strong influences against its adoption. Granting, however, that an all-timber, or brick and timber structure is lowest in first cost, then an all-steel construction, with corrugated iron sheeting, is next in order of economy, while brick and steel construction is usually rather more expensive.

For a permanent factory or works, however, where a manufacturing process is to be carried on under shelter, a steel structure with brick walls, either built or filled, is almost universally used. A metal covered steel construction is again almost universally adopted where the manufacturing process is of

such a nature that absolute protection from wind and weather is not of first importance.

Influences Tending to Remodelling of Buildings.

The first important influence operating towards the remodelling of industrial buildings can quite safely be said to have been the introduction of electricity. The ease with which electricity can be generated and distributed has influenced the erection of works with less consideration for concentration of the driving arrangements, and with greater consideration for suitability to the manufacturing process.

Again, the development of the traveling crane has had a marked effect in altering the character of engineering, and other works establishments. With traveling cranes and shafting, the consideration of internal stresses is important, because any excessive movement in the structure will bring about shafting troubles, and any lack of rigidity may quite easily have a serious effect upon the operation of traveling cranes. The stresses due to the stopping, starting, and running of high speed traveling cranes are very considerable. A point frequently neglected, in designing sheds where cranes are in use, is effective diagonal bracing of the structure to prevent racking, through end traveling on the one hand and cross traveling on the other.

Weather Influences.

The external forces to which an industrial structure may be subjected are wind and snow loading. Generally speaking, if a structure is designed to resist the side and roof stresses from wind loading, and to have a fair margin of safety, any snow loading which may arise can be neglected. Among civil engineers it would be quite easy to raise a heated debate upon the question of the wind loading on structures. A very great deal of work is being put up, even to-day, which can only be said to withstand the wind stresses to which it is subjected by courtesy of an indulgent Providence, and, on the other hand, there is a large amount of work being made of an unduly extravagant character.

To advocate the abolition of wind bracing would be foolishness, but it is the ease that wind bracing is being carried by many designers to an extent which is extravagant and difficult to excuse. A well designed roof truss, having its ends thoroughly connected to the roof girders, having good spreading plates, moderate purlins, and a corrugated sheet roof well and properly laid, must by itself, by virtue of the continuity of the roofing, be a reasonably well braced structure. The value of a roof, whether of timber or corrugated

iron, as what might be termed wind bracing, is considerable, and given sound end connections, it is somewhat difficult to see the reason for the adoption of an elaborate system of longitudinal or diagonal wind ties across the lower members of the roof frames.

Crane Influences.

In buildings in which there are cranes, the area between the main pillars and under the crane beams may be left quite clear, since if the pillars are stiff enough, and their strength is carried through to the top of the crane beams, and if, in addition, a moderate amount of diagonal bracing is introduced above the crane rail level, then the upper part of the structure between the crane and roof girders virtually becomes a deep lattice, having the crane girder as its lower member, the roof girder as its upper member, and the continuation of the pillars carried up to take the roof as its end members, the lattice bracing filling the intervening space. With such a structure, the resistance to the heavy stresses set up by the traveling cranes is usually well provided for.

In general with long spans, if bracing is carried down in a vertical plane from the lower member of the roof tie to the roof pillar, and sideways in a horizontal plane from the same lower member to the roof girder, these diagonal connections tune up the whole structure in a reliable manner.

Detail Design.

The detail design of industrial buildings is as interesting as the design of power plant, and contains as great an amount of detail. One or two notes on the principal characteristics, however, may be interesting.

Pillars are as varied in design almost, as are ideas of designers. Simplicity of construction and continuity of strength ought to be kept clearly in view in designing a pillar. It is always advisable to remember that shafting brackets are required in works, and that a flat surface to the outside of the pillar is very frequently of considerable value. There is quite a strong tendency among designers to carry shafting through pillars by placing neat plate platforms in between the vertical members. This arrangement makes it difficult to remove the shafting, but it gives a much more rigid arrangement than any form of bracket can give.

Pillars.

A most satisfactory pillar design has three I beams, the two outer carried up to the cranes, and the centre one carried to the roof valley girder. This design might almost be regarded as standard in its several modifications. It se-

cures continuity in the pillar section, continuity in the girders, and a sufficient side support for each. A modification of this design carries up two I beams to the crane beams with a short length spliced between them at the top to carry the roof valley. For simple pillars, broad flanged joists make most useful designs, but plated joists, lattice channels, latticed angles, and many other simple forms are in use.

For heavy cranes, on special spans, box girders have been used for many years. These are, as a rule, cambered on the underside for the longer spans, and have a bridge section rail riveted on top. Built girders are, however, now becoming very common for longer spans.

Generally speaking, well designed lattice girders compare very favorably in cost with any other form of construction for spans over 25 feet.

Roof Principals.

As with pillars, so with roof principals. In designing a roof, where the structure is of steel, it should be borne in mind that the roof principal is but a continuation of the side frames to carry the overhead covering, and serves to resist its share of the wind load on the side of the structure. For this reason, then, the fixing at the ends of the principals must be sound and well spread. Good broad roof shoes, with well formed knee plates at the pillar heads, and diagonal struts both vertical and horizontal, greatly assist to maintain rigidity. The lower member of the roof truss ought also always to have a moderate camber, in order to take away the appearance of sagging which follows upon a straight line construction.

The standard type of construction in England is a roof having a pitch of approximately 30 degrees. In America, very much flatter pitches are in general use, and on the Continent designs having two pitches are common. This latter type of roof makes a very desirable design. In America, shafting, and even motors, are frequently suspended from the roofs, the principals of which are usually much heavier than in British practice. No doubt this practice will develop with the spread of electrical driving in Britain.

A small point which ought to be borne in mind is that, while a little license may be dangerous, it is always quite desirable for a roof to have a sufficient margin of strength to permit workmen, under certain circumstances, to take a light lift from a plank put across the roof principals, and that where cranes are not provided, the roof may be locally and permanently stiff-

ened to take special recurring, but infrequent lifts. Beyond these details, there are a vast number of interesting items arising in connection with works buildings. Roof glazing, and side and end covering where the whole structure is of steel, the design of the brickwork for gables, and in steel structures for filling, details of purlins, lattice purlins, ventilators, gutters and down pipes, of floors, tool rooms, stores, lavatories, men's rooms and offices, of heating, lighting and ventilation, and many others, all of these present opportunity for neat and tasteful design. Enough has, however, been said to indicate how interesting to the mechanical engineer-designer the retail design of an industrial works may become.

VI.—Works Reconstruction.

The reconstruction of existing works is as important as the building of new works. The problems are usually of similar character, but the development difficulties are greater, because it is generally necessary to keep a works running while the reconstruction scheme is being developed.

Conclusion.

In conclusion, under the industrial conditions which hold to-day and are becoming increasingly stringent, no manufacturer building or reconstructing works or mills can afford to neglect the technical skill which is at his disposal, quite irrespective of cost. It may be argued that a works manager or proprietor knows most about his business and its needs. This point has already been mentioned, but it can quite legitimately be urged that the proprietor's business may be the mining of coal, the manufacturer of iron or steel, of ships, of chemicals or of textiles. In that sphere he works at his best, his efficiency is a maximum. In the design of buildings, the selection of power plant, or even the economical arrangement and correlation of these, he is at a disadvantage.

Whether this disadvantage is serious or may only involve a permanent tax upon his business, when accepted, must be left to his own judgment. The author merely calls attention to the fact that those industries which hold a world-wide reputation in America, in Germany, and even in Great Britain, have in every instance had the advantage of being originally designed or reconstructed at some point in their recent history by experts in collaboration with engineering skill either manufacturing or professional. As already pointed out, the skill and energies of the engineer are essential to the birth and growth of every modern manufacturing industry.

DEVELOPMENTS IN MACHINERY

A Record of New and Improved Machinery Tending Towards Higher Quality and Economical Production in the Machine Shop, Blacksmith Shop or Planing Mill.

DUPLEX HORIZONTAL DRILL.

THIS new design of drill embraces improvements; first, in the matter of design to escape all troubles from chips interfering with the free sliding of heads on their ways, and second, in giving an adjustment to each head, which will allow of using a short worn drill in one head, and a long new drill in the opposite head. This adjustment is used in a number of ways for a number of benefits. Where work is to be faced to shoulders, working from fixed points, either head can be adjusted for the necessities of snap gauge work, and as the tool wears or is ground, this adjustment will allow of resetting for the maintenance of the over all facing length. The details are shown in the accompanying cuts.

The ball handle, through spiral gears, rotates a nut, which is unclamped by the eccentric binder, and reclamped after the proper adjustments are made. The heads are kept to their bearings by taper gibs, gibbing from below the Vees on both sides. The heads are fed forward by a hardened screw—cut right-hand on one end and left-hand on the other end, by means of intermediate bevel gears from the power feed box. This worm gear shaft is extended to receive the capstan shown in illustration, with handle for quick return.

The spindle is of special construction, being hardened and ground all over.

Both front and rear bearings are of the taper variety, and in adjusting this spindle, it is necessary to slack off the nut lock (A), back off the thrust screw

(D), and slack off nut (E), until, by turning the driving pulley, free rotation of the spindle is secured, after which the thrust screw (B) is brought to touch

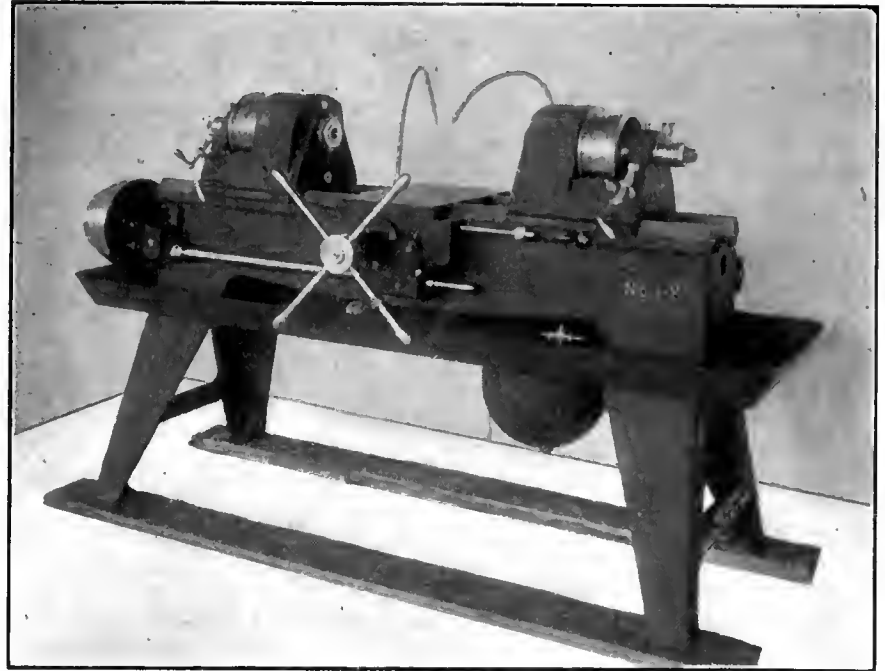

DUPLEX HORIZONTAL DRILL.

(B), also nut (D) on the front box, and tighten up on nut (E), drawing front box and the spindle back into the rear bearing. After doing this, tighten nut

the nut (C) jammed, and nut lock (A) is entered into notched recess in nut (E).

As noticed in the illustration, the

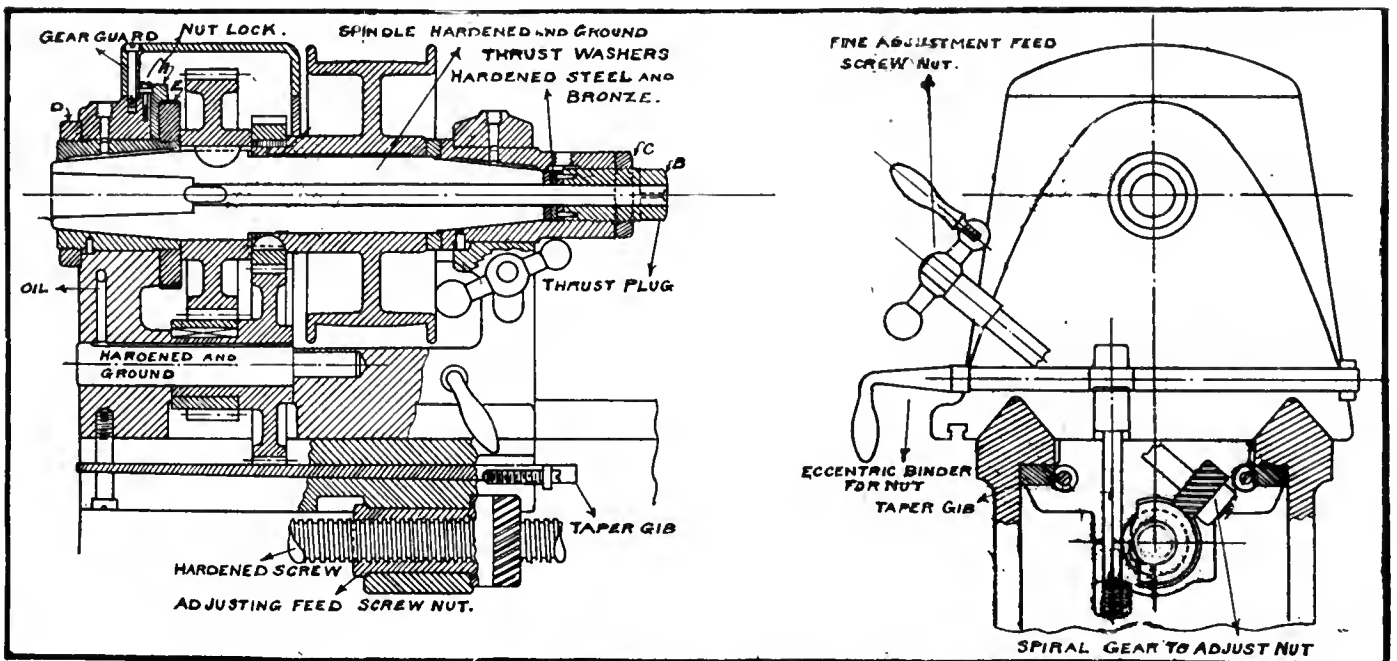

DETAILS OF DUPLEX HORIZONTAL DRILL.

backgearing, which is 3 to 1, is well housed, giving protection to the operator, as well as protection from injury to the gears themselves. The makers are The Garvin Machine Co., Spring & Varick Sts., N.Y. city, and the weight, including countershaft, is about 2,000 lbs.



LARGE PRESS FOR FORMING AUTOMOBILE SIDE FRAMES.

THE accompanying illustrations give a clear idea of the construction of a side frame press recently designed and built by the E. W. Bliss Co., of Brooklyn, N.Y., for one of the largest manufacturers of automobile parts in France. This, the largest machine of its type yet built, shows a new design of press recently developed and exclusively built by the above firm. The moving table has an area of 18 feet in length by 3 feet in width, and the machine is capable of forming side frames of $\frac{1}{4}$ -in. chrome nickel steel up to 18 feet in length.

It will be seen that the moving table is raised by four solid connecting rods which are fitted to the crank shaft, the connecting rods being equally spaced over the entire length. Lubrication of the connection is by a high pressure oil pump mounted on the back of the moving table, as illustrated. Adjustment for depth of drawing is provided by the nuts holding the upper head. The dis-

tance between the moving table, when up, to the bottom of upper head, with adjustment all up, is 32 inches, while the upper head has an adjustment of 22 inches.

solid. It will be seen that the machine is twin-driven, being provided with a gear on each end of the crank shaft. These gears are driven through treble reduction gearing, the driving gear which

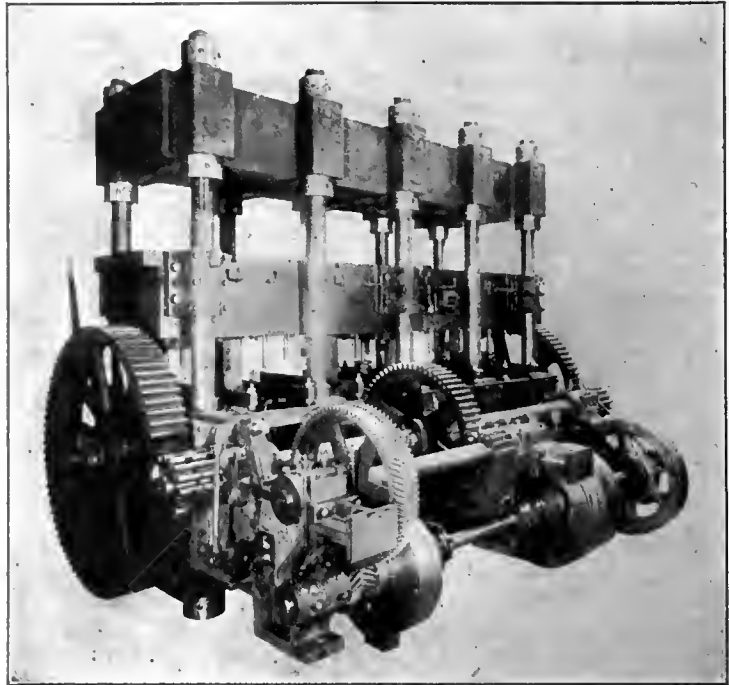

REAR VIEW OF AUTOMOBILE SIDE FRAME PRESS.

Owing to the stress to which the upper head, moving table and gearing are subjected, these parts are steel casting and the gearing is machine cut from the

imparts power to the main gears being placed centrally, thereby overcoming all torsional strain on the main back shaft. Control of the machine is secured by a powerful double grip friction clutch, operated by hand, thus giving the operator complete control of the moving parts at any point of the upward or downward movement. The driving pulley as well as the flywheel is provided with a shearing pin, which operates to prevent injury to the press, when through carelessness or otherwise, a wrench, bar, or some foreign article is left on the top of the die, or when the pin is not adjusted properly as regards the shut height of dies.

Provision is made for ejecting the formed work from the sunk die on the lower table by knockout bars mounted inside, and a series of holes in the moving table permits the knockout pins to be placed in the proper position to eject the formed work. The total weight of machine is 300,000 lbs., and the power required to operate it at maximum capacity is 75 horse-power.

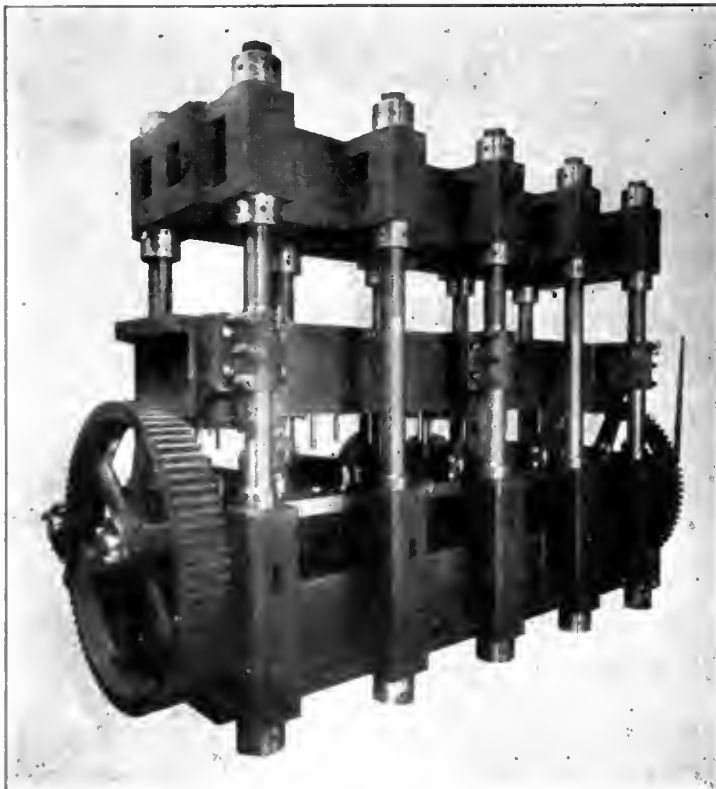

FRONT VIEW OF AUTOMOBILE SIDE FRAME PRESS.

Orangeville, Ont.—The Dadds Knitting Factory of Alton are seeking a loan of \$30,000 to assist in building and fitting a \$50,000 factory in Orangeville. The company will employ 60 hands and have a pay roll of \$20,000 per year. Voting on by-law takes place in June.

CANADIAN CAR & FOUNDRY CO:

The Canadian Car & Foundry Co., Ltd., Montreal, Que., is proceeding with its new plant at Fort William, Ont. This will be one of the largest car plants in the Dominion, being modernly built and equipped in every respect, also practically fireproof, and will have capacity for all kinds and classes of both wood and steel freight car equipment. It will also have its own foundries, spring shop, etc.

The Turot and Dominion plants in Montreal have been enlarged considerably to meet the growing requirements of business; the capacity of both plants having been practically doubled within the last three years. The company's plant at Amherst has also been enlarged, all new construction work being of a permanent character. At present the company is putting up a plant for the manufacture of steel car equipment, including bolsters and brake beams, as well as a spring shop. The malleable foundry at Amherst has been enlarged to nearly three times its original capacity.

Considerable improvements have been made on the Welland plant of the Canadian Steel Foundry Co., Ltd., the stock of which is entirely owned by the Canadian Car & Foundry Co., Ltd. The latter also recently purchased by stock ownership the malleable fireproof plant of the Pratt & Letelworth Co., at Brantford, Ont.

The company has orders on its books at the present time sufficient to keep its plants going for the remainder of the year.

SAVINGS BANK FOR FACTORY.

BESIDES having a welfare association and other benefits for their employees, the McClary Manufacturing Co., London, Ont., inaugurated a savings bank for their workers which paid interest at the rate of 4 per cent. on all money deposited. This was done because it was not convenient for the men to go to the banks during banking hours, and for other reasons. It was believed that money sometimes burned a hole in a man's pocket.

Since it was started some five years ago, the plan has worked splendidly. The first year some \$5,000 was received from the employees. There has been a large advance every succeeding year as the plan became understood, and last year between \$30,000 and \$40,000 was deposited.

One of the provisions of this scheme is that money can only be drawn out at the end of the year. One instance showing that this is a good rule can be related. An employee suddenly took to drinking, and, after spending the money he had saved outside the firm's bank,

pawned his tools. When the money he received from these was gone, he demanded the \$150 he had on deposit in his employers' bank. His demands being turned down, he took his ease to a lawyer. The latter had a conference with Col. Gartshore, the head of the McClary firm, who explained the circumstances. The lawyer thereupon informed the man that his employers had a perfect right to keep his money. The result was that the man went back to work, and is now adding regularly to his nest egg of \$150.

A RIVET HEATER WITH FORCED DRAUGHT.

AN improvement over the ordinary gas rivet heater is shown in the accompanying illustration. The air, instead of

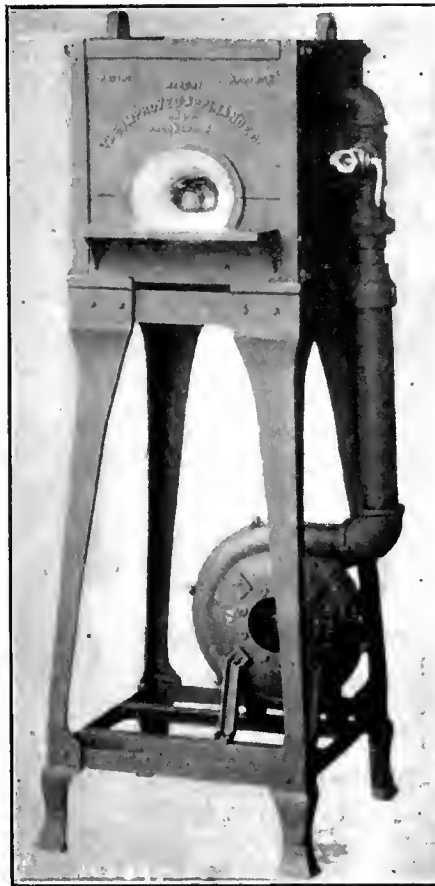

A RIVET HEATER WITH FORCED DRAUGHT.

being supplied without pressure through valves, is forced in by means of a small motor-driven blower, thereby producing more intense heat and utilizing the gas more efficiently. The action of the furnace is therefore very rapid and economical. The rivets are fed in at the top and drawn out at a port in front. Special arrangements are provided to prevent oxidation of the rivets and to protect the operator from excessive heat. The furnace uses any kind of gas, and the motor is operated from the electric

light circuit. The Improved Appliance Company, Brooklyn, N.Y., are makers of the furnace, and Westinghouse small motors are used for driving the blowers.

RAILWAY TRAGEDIES OF U.S.

EFFECTIVE railroad equipment and tracks were responsible for 68 per cent. of all derailments in the United States during July, August and September, 1912, when there were 934 more train accidents, including 901 more collisions and derailments, than there were during the same months of 1911. All train accidents on steam roads during that time killed 288 and injured 4,598.

Accidents of other kinds, including those sustained by employees while at work, make the number of casualties —2,995 killed and 22,447 injured; a total increase of 237 killed and 3,340 injured. The damage to equipment and roadway by the accidents aggregated \$3,366,401, a large increase.

NEW STEEL PROCESS.

GREAT interest has been aroused in Sheffield in the method of producing superior high-speed steel by the introduction of cobalt. The process is patented throughout the world by a continental firm, but there are indications that at Sheffield, the centre of the British high-speed steel industry, the manufacturers will fight for the privilege of making the new steel without having to pay royalties under the foreign patent. The new material, they claim, will mark a great advance on the best qualities of steel at present obtainable for boring and cutting tools.

F. N. Gardner, President of the Gardner Machine Co., Beloit, Wis., and a prominent figure in the machine tool industry, died on May 11, after a brief illness. Mr. Gardner was born in Ashfield, Mass., 63 years ago, and began his Western career in 1888. In 1890 he became superintendent and general manager of the C. H. Besly Co., in which position he continued until 1905 when he established the Gardner Machine Co. The deceased gentleman was the possessor of a keen and ingenious mechanical vision, and his lifework as a mechanic was replete with illustrations of mechanical skill. He took a vital interest in furthering industrial education movements of his section, and had won a reputation as a public-spirited citizen of Beloit. He is survived by his wife, two daughters and five sons.

MACHINE SHOP METHODS ^A_ND DEVICES

Unique Ways of Doing Things in the Machine Shop. Readers' Opinions Concerning Shop Practice. Data for Machinists. Contributions paid for.

HELPING THE TOOLMAKER.

By Albert A. Dowd.

THE tool designer's work depends largely for its success or failure upon the skill and accuracy of the toolmaker, who carries out in metal the ideas presented to him on paper. It is necessary, then, for the most intelligent development of these ideas that the harmony between the two men should be as nearly perfect as possible, in order that the best results be obtained. There are many ways in which the work of the toolmaker may be materially lightened and simplified by a little care on the part of the designer in making his drawings, principally by making each one as complete as possible, and not leaving certain important data "to be looked up later."

Working Drawings of Jigs and Fixtures.

Properly made, a working drawing should "tell the whole story" of exactly what is wanted without leaving anything whatever to be "guessed at," and should furthermore carefully emphasize the important points. It should give limits of permissible error, espe-

cially on jig and fixture work, and if jig must "tie up" with some other, it should be so stated that no mistake can be made. If "fit to gauge," the piece number and department where it may be found should be plainly noted on the drawing. Dimensions should be given from conveniently accessible surfaces and not from some imaginary centre line, which may be convenient for the designer, but which is somewhat difficult for the toolmaker to locate on a rough piece of cast iron.

Take the dimensions of a jig drawing, as an instance. It not infrequently happens that these dimensions are so given that it may be extremely awkward to attempt to work from them, and for the sake of greater ease and convenience in working, the toolmaker is obliged to re-dimension the drawing to suit the conditions under which he is working, possibly using entirely different "working points" from those given. This involves more or less figuring and obviously requires time, and there is also the additional chance for errors to creep in and cause trouble.

Now it is a small matter for the draftsman to consult with the foreman regarding the most convenient surfaces

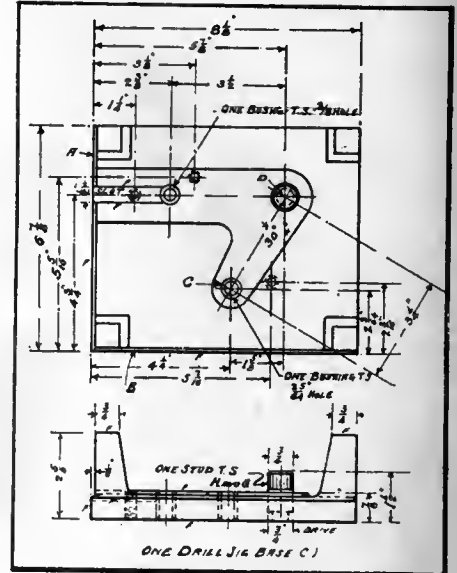
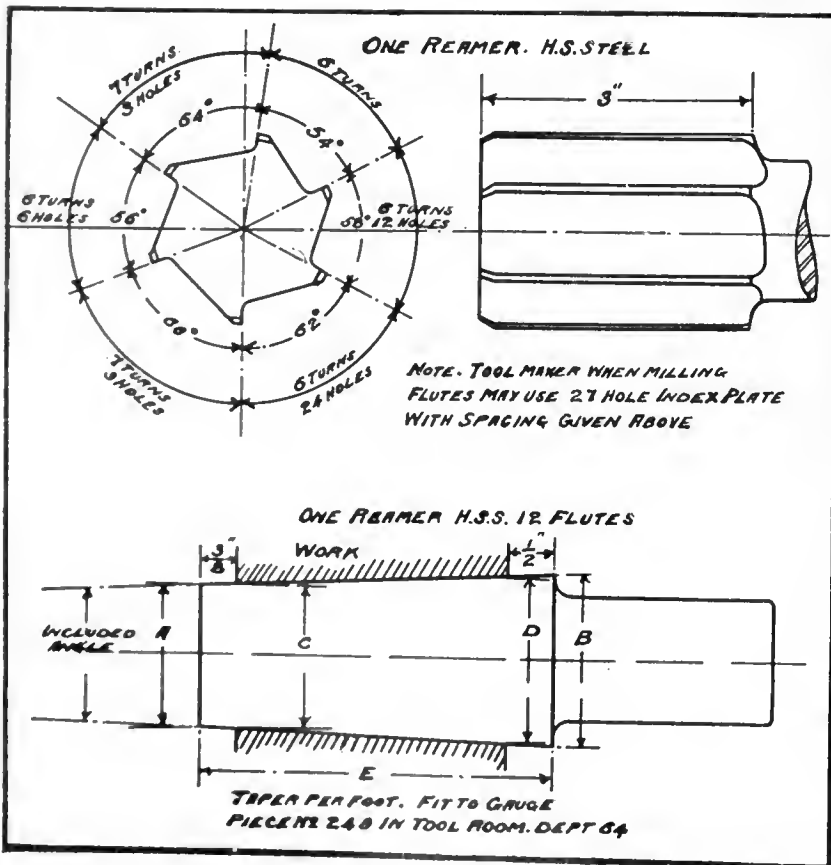

FIG. 1. DRAWING OF DRILL JIG BASE.

from which to work, and then, when the drawing is completed and in the shop, if there should be any question, the toolmaker will naturally take it to his foreman. Having decided exactly how the work is to be done (in his previous conversation with the draftsman), he is prepared to recommend the proper method of handling.

Figure 1 shows a drawing of a drill jig base, on which all the important dimensions are given either from the "base lines" (A) and (B), or from the centres of bushing or stud holes. In this instance, it is a very easy matter for the toolmaker to obtain his measurements without recourse to any figuring at all, as all locations are so readily found that no trouble should be experienced. It will be also noted that the bushing hole (C) is located both from the base lines (A) and (B), and from the centre of the stud (D), thus giving a "cheeking measurement" for calipering. Whenever possible, a bushing location should be "tied up" with some other for calipering purposes. This is especially desirable in cases where great accuracy is required, for this saves the toolmaker a considerable amount of figuring, which would otherwise be necessary, in order to prove his work.

When drawings of forged tools are made, it is always well to state the ma-



FIGS. 2, AND 3. DRAWING SHOWING REAMER DATA.

terial upon which the tool is to be used, viz., "for cast iron," "for brass," "for steel," etc., in order that the tool may be given the correct amount of "hook" or "lip." On reamer drawings the number of flutes should be specified, and, if spiral, give the "lead" and angle of the spiral, together with the correct angle to which the milling machine table must be "set over" in order to produce it. If "staggered tooth" reamers are designed, it is a great convenience to the toolmaker if, in addition to the angular tooth-spacing, the drawing also gives the "index plate" needed, together with the number of turns required for each "flute"; see Fig. 2. This makes it unnecessary for the mechanic to do any figuring at all, as he has all the information needed to proceed at once with the work.

On taper reamers, which are usually made longer than the work to be reamed, both the "taper per foot" and the "included angle" of the taper should be given, so that there may be no possible chance for an error. In connection with this matter, the writer very recently was obliged to hold up an order for some taper reamers just because drawing dimensions were incomplete, "taper per foot" being given and the diameter at the large end, but no angle or dimension at the small end appearing on the drawing. In addition to this, the taper shown was about double that called for, which obviously left the matter somewhat in doubt, necessitating a

delay of nearly two weeks on an important order.

It will be thus seen how much trouble may be avoided by making sure that all important dimensions are on the drawing before it is sent out into the shop. Make sure that the diameters at (A)

is easier to make, although it does not look so well, is shown by Fig. 5. Here the washer is bevelled off, the bevels on each face being made at right angles. The hole in the collar is drilled large, as is also that illustrated in Fig. 4. This permits of a correct clamping action.

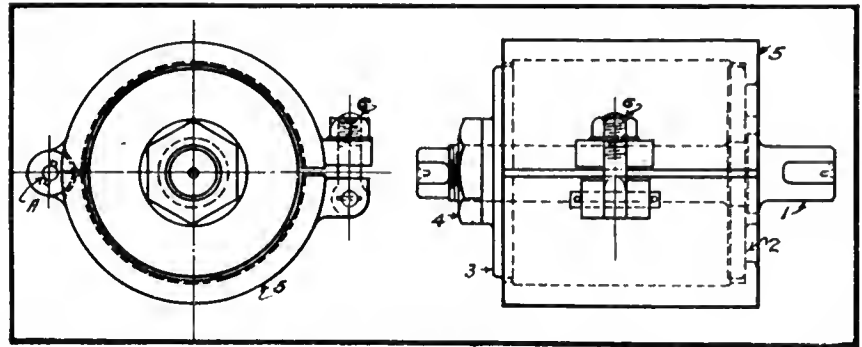

A PISTON RING MANDREL.

A PISTON RING MANDREL.

By W. A. P.

and (B) are carefully noted and the length (E). If the reamer is to be made to ream work for which a gauge has been provided, measure the plug and figure the taper from that, making such suitable allowances at each end as may be required by the conditions, also noting on the drawing "fit to gauge," specifying where the gauge is to be found; see figure 3.

The toolmaker will appreciate this wealth of information, as it saves him considerable trouble, and the draftsman also will find the work in process in the shop moving along with fewer requests to "step down into the toolroom for a few minutes." The result is a gain for both parties.

THIS mandrel and jig has given good service in finishing small piston rings after they have been cut, and perhaps it will be of some help to others engaged on similar work. Figure 1 shows the mandrel with the clamping flanges tight, figure 2, and with the flanges loose, figure 3. A clamping nut on the threaded portion of the mandrel is shown by figure 4. A cast-iron casing split and hinged at (A) is indicated by figure 6, and for the purpose of closing the halves of the casing together, the eye-bolt, figure 6, is fitted. The ends of this casing are bored slightly larger than the mandrel flanges. It is also recessed as shown.

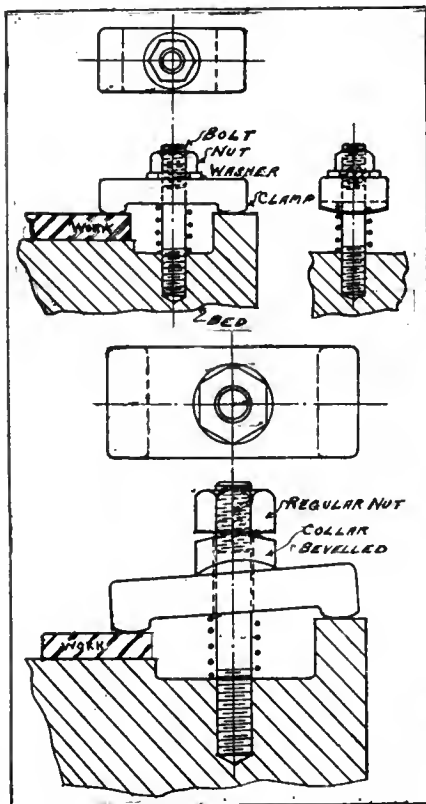

CLAMPING WORK, FIGS. 1 AND 5.

CLAMPING WORK, THE CORRECT WASHER TO USE.

By F. M.

WHEN holding rough work in a machine with a clamp such as is shown by Fig. 1, if the nut is serewed tight against the clamp with a plain washer, Fig. 2, between the nut and clamp, the threads of the nut and bolt will be sprung out of true or strained, owing to one side being higher than the other, which causes the nut to bind on one (shown much exaggerated by Fig. 3) corner, and any further clamping to spring the bolt into correct alignment or until the face of the nut and washer come together. To correct this faulty binding action it is desirable to use a cupped nut and washer, Fig. 4, one (shown much exaggerated by clamped without springing the bolt, as the washer will float to correct alignment.

Another type of nut and washer which will answer the same purpose and

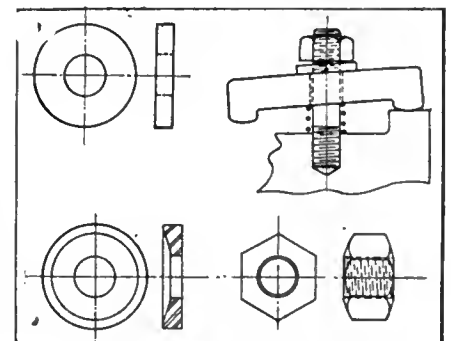

CLAMPING WORK, FIGS. 2, 3, 4.

To operate:—Remove the nut, figure 4, and the flange, figure 3, and place the end of the mandrel, figure 1, through a hole so that the jig will rest steady on the bench. Open the casing slightly and place the rings one above the other, taking care not to have two cuts coming together. Replace the flange and nut, close the casing with eye-bolt (6) and clamp the rings tightly with nut (4). Next remove the casing, and the rings are in position to finish.

The MacLean Publishing Company

LIMITED

(ESTABLISHED 1888.)

JOHN BAYNE MACLEAN - - - - - President
H. T. HUNTER - - - - - General Manager

PUBLISHERS OF

CANADIAN MACHINERY AND MANUFACTURING NEWS

A weekly newspaper devoted to machinery and manufacturing interests, mechanical and electrical trades, the foundry, technical progress, construction and improvement.

H. V. TYRRELL - - - - - Business Manager
PETER BAIN, M.E. - - - - - Editor.

OFFICES:

CANADA

Montreal, Rooms 701-702 East-
ern Townships Bank Bldg.
Toronto, 143-149 University
Ave., Phone Main 7324
Winnipeg, 34 Royal Bank
Bldg., Phone Garry 2313
Vancouver, H. Hodgson, 2640
Third Ave. West.

GREAT BRITAIN

London, 88 Fleet Street, E.C.
Phone Central 12960
E. J. Dodd

UNITED STATES

New York, R. B. Huestis, 115
Broadway, New York, N.
Y., Phone 2209 Rector
Chicago, A. H. Byrne
Room 607, Marquette Bldg.
140 S. Dearborn St., Chicago

CABLE ADDRESS:

Macpubco, Toronto. Atabek, London, Eng.

SUBSCRIPTION RATE:

Canada, \$2.00; United States, \$2.50; Great Britain, Australia
and other colonies, 8s. 6d. per year; other countries, \$3.00. Adver-
tising rates on request.

Subscribers who are not receiving their paper regularly will
confer a favor on us by letting us know. We should be notified at
once of any change in address, giving both old and new.

Vol. IX.

MAY 29, 1913

No. 19

PRINCIPAL CONTENTS.

Description of New C.P.R. Shops, Ogden, near Calgary, Alta.	557-562
General	562
Welding, Electric and Oxy-Acetylene—Standardization of Electrical Machinery—U.S. Steel Corporation in Canada.	
The Layout, Design and Equipment of Industrial Works	563-568
Developments in Machinery	569-571
Duplex Horizontal Drill—Large Press for Forming Auto- mobile Side Frames—A Rivet Heater With Forced Draft.	
General	571
Canadian Car & Foundry Co.—Savings Bank for Factory —Railway Tragedies of U.S.—New Steel Process.	
Machine Shop Methods and Devices	572-574
Helping the Toolmaker—A Piston Ring Mandrel— Clamping Work, the Correct Washer to Use.	
Editorial	574
Selected Market Quotations	575-576
The General Market Conditions and Tendencies	576-577
General	577
Kootenay Lake Vessel Contract—Wm. Kennedy & Sons Owen Sound—New Merger, Steel Products of Canada— Graphite Cupola Stoppers—Manufacturers Going East.	
Industrial and Construction News	578-582
Engineering—Electrical—Waterworks—Woodworking— Municipal—Building Notes—General Industrial—Contracts Awarded—Railways, Bridges—Trade Gossip—Tenders Personal—Obituary—New Incorporations—Catalogues— Book Reviews.	

A HIGHLY CREDITABLE PERFORMANCE.

OUR leading article, descriptive of the new C.P.R. shops at Ogden, near Calgary, Alberta, indicates in an unmistakable manner, the capacity for compassing big undertakings possessed by the Westinghouse Church, Kerr

Co. of Montreal and New York. Not only has a thoroughly well-found and well-equipped plant been placed at the disposal of our premier railroad, for rolling stock, but possession has been given, and the work for which it was planned has now been in progress for some considerable time.

No more encouraging sign of the continued and growing prosperity of the Dominion can be forthcoming, than that evidenced in the desire of our great railroads to provide for the upkeep of their rolling stock at points more or less remote from headquarters, and the requirement, once a decision has been arrived at to locate a plant, that the work be performed within a stated and brief space of time. The latter circumstance makes clear that business demands are pressing, and, therefore, are indicative of a healthy and prosperous condition existing.

INDUSTRIAL ENGINEERS.

CONSIDERABLE space has been devoted in the present issue of Canadian Machinery to an article on the Layout, Design and Equipment of Industrial Works, and not the least outstanding feature among the many interesting points raised is that of the existence of the industrial engineer and the necessity for his recognition in the matter of expert advice and service, in order that a plant suitable for a given manufactured product may be raised.

The author of the paper takes occasion to pay manufacturers on this continent the compliment of having long ago recognized the place of and necessity for the industrial engineer both when locating a completely new plant and when extending and adding to existing layouts. However, we are still open to secure pointers in respect of the employment of such specialists, and to progress still further towards perfection, even should it follow the results of comparisons drawn between factories on this continent and those in Great Britain. While generally speaking, we are well ahead in the matter of recognition of the place and part of the industrial engineer, there are instances, yes, of quite common occurrence, in which we find the manufacturer's staff performing, or at least attempting to perform the work. Where this condition of things prevails, the reason is usually attributed to some comparatively highly placed official of the concern pluming himself on his capabilities.

As time goes on, however, and as training and experience become more developed in the profession of industrial engineering, there is bound to disappear all tendency on the part of responsible manufacturers to muddle along with a staff engaged for the production of some specialty, and who for the time being turn plant designers. The fact that the factory must be laid out and equipped to suit the product in its every phase, must not be lost sight of, and in most cases, be it noted here, there exists the constitutional difference between the work of the expert and that of the factory staff. The former as has been said operates with an eye to the products, all the time, while the latter, in the last analysis, generally have to trim the product to suit their handiwork.

Reverting back to the contents of the paper generally and the principles by which those about to embark on factory installation or extension should be guided, it is not in any way giving the author over credit when we say that his discussion of the subject is masterly, and that he exercises an entire familiarity with its many sides. Readers of every rank and position in our factories will find the data interesting and instructive.

SELECTED MARKET QUOTATIONS

Being a record of prices current on raw and finished material entering into the manufacture of mechanical and general engineering products.

PIG IRON.

	Per Ton.	
Foundry No. 1 and 2, f.o.b., Midland	\$19 00	\$19 50
Gray Forge, Pittsburg	16 15	
Lake Superior, charcoal, Chicago	18 00	
	Mont'l. Tor'to.	
Canadian f'dry, No. 1..	\$21 00	\$20 00
Canadian f'dry, No. 2..	20 50	19 50
Middlesboro, No. 3....	23 50	23 50
Summerlee, No. 2	25 00	26 50
Carron, special	25 00	
Carron, soft	25 00	
Cleveland, No. 1	24 25	25 00
Clarence, No. 3	23 75	24 50
Jarrow	25 50	
Glengarnock	26 00	
Radnor, charcoal iron.	30 00	34 50
Ferro Nickel pig iron (Soo)	25 00	

BILLETS.

	Per Gross Ton.	
Bessemer billets, Pittsburgh	\$28 50	
Open hearth billets, Pittsburgh.	29 00	
Forging billets, Pittsburgh.....	36 00	
Wire rods, Pittsburgh	30 00	

FINISHED IRON AND STEEL.

Per pound to large buyers:

Cents.

Common bar iron, f.o.b., Toronto..	2.10
Steel bars, f.o.b., Toronto.....	2.20
Common bar iron, f.o.b., Montreal.	2.15
Steel bars, f.o.b., Montreal.....	2.25
Bessemer rails, heavy, at mill....	1.25
Iron bars, Pittsburgh	1.70
Steel bars, Pittsburgh, future	1.40
Tank plates, Pittsburgh, future...	1.45
Beams, Pittsburgh, future	1.45
Angles, Pittsburgh, future	1.45
Steel hoops, Pittsburgh	1.60

Toronto Warehouse f.o.b., Toronto.

Cents.

Steel bars	2.30
Small shapes	2.40

Warehouse import, freight and duty to pay:

Cents

Steel bars	1.95
Structural shapes	2.05
Plates	2.05

Freight, Pittsburgh to Toronto:

18 cents carload; 21 cents less carload.

BOILER PLATES.

	Mont'l. Tor'to.	
Plates, ¼ to ½-in., 100 lbs.	\$2.35	\$2.35
Heads, per 100 lbs.....	2.65	2.95
Tank plates, 3-16 in.	2.60	2.60
Tubes, per 100 ft., 1 inch	9.00	8.50
" " 1¼ in.	9.00	8.50
" " 1½ "	9.00	9.00
" " 1¾ "	9.00	9.00
" " 2 "	8.75	8.75
" " 2½ "	11.50	11.50
" " 3 "	12.00	12.00
" " 3¼ "	13.75	13.75
" " 3½ "	14.50	14.50
" " 4 "	18.00	18.00

BOLTS, NUTS AND SOREWS.

	Per cent.
Stove bolts	80 & 7½
Machine bolts, ¾ and less	65 & 5
Machine bolts, 7-16.....	57½
Blank bolts	57½
Bolt ends	57½
Machine screws, iron, brass	35 p c.
Nuts, square, all sizes.....	4c per lb off
Nuts, Hexagon, all sizes..	4¼ per lb off
Flat and round head.....	35 per cent.
Fillister head	25 per cent.
Iron rivets	60, 10, -0 off
Wood screws, flathead, bright	85, 10 p c off
Wood screws, flathead, brass	75, 10 p c off
Wood screws, flathead bronze	70, 10 p c off

"National-Acme "Milled Products."

Sq. & Hex Head Cap Screws	65 & 10%
Sq. & Hex Head Cay Screws	65 & 10%
Rd. & Fil. Head Cap Screws	45-10-10%
Flat & But. Head Cap Screws	40-10-10%
Finished Nuts up to 1 in. . .	75%
Finished Nuts over 1 in. . .	72%
Semi-Fin. Nuts, up to 1 in..	75%
Semi-Fin. Nuts over 1 in....	72%
Studs.....	65%
Discounts f.o.b., Montreal.	

WROUGHT IRON PIPE.

The following are Toronto jobbers' discounts on pipe in effect from April 21, 1913:

	Butt-weld		Lap-weld	
	Black	Gal.	Black	Gal.
¼ ¾ in.	62	47
½ in.	68	58
¾ to 1½ ...	71½	61½	68½	58½
2 in.	71½	61½	68½	58½
2½ to 4 in. . .	71½	61½	70½	60½
4½ to 6 in.	71½	61½
7, 8, 10 in.	66	54

X Strong P. E.

¼, ⅜, ½ in. . .	56½	46½
¾ to 1½ in. . .	67½	57½
2 to 3 in.	68½	58½
2½ to 4 in.	65	55
4½ to 6 in.	64	56
7 to 8 in.	55	45

XX Strong P. E.

½ to 2 in.	43	33
2½ to 4 in.	43	33

PRICES OF WROUGHT IRON PIPE.

Standard. Nom. Diam.	Price. per ft.	Extra Strong.		D. Ex. Strong.	
		Sizes Ins.	Price per ft.	Sizes Ins.	Price per ft.
⅛ in	\$.05½	⅛ in	\$.12	½ in	\$.32
¼ in	.06	¼ in	.07½	¾ in	.35
⅜ in	.06	⅜ in	.07½	1	.37
½ in	.08½	½ in	.11	1¼	.52½
¾ in	.11½	¾ in	.15	1½	.65
1 in	.17½	1 in	.22	2	.91
1¼ in	.23½	1¼ in	.30	2½	1.37
1½ in	.27½	1½ in	.36½	3	1.86
2 in	.37	2 in	.50½	3½	2.30
2½ in	.58½	2½ in	.77	4	2.76
3 in	.76½	3 in	1.03	4½	3.26
3½ in	.92	3½ in	1.25	5	3.86
4 in	1.09	4 in	1.50	6	5.32
4½ in	1.27	4½ in	1.80	7	6.35
5 in	1.48	5 in	2.08	8	7.25
6 in	1.92	6 in	2.86
7 in	2.38	7 in	3.81
8 in	2.50	8 in	4.34
8 in	2.88	9 in	4.90
9 in	3.45	10 in	5.48
10 in	3.20
10 in	3.50
10 in	4.12

IRON PIPE FITTINGS.

Canadian malleable, 40 per cent.; cast iron, 65; standard bushings, 70; headers, 60; flanged unions, 65; malleable bushings, 65; nipples, 75; malleable, lipped unions, 65.

COKE AND COAL.

Solvay Foundry Coke	5.95
Connellsville Foundry Coke	5.45
Yough, Steam Lump Coal	3.83
Penn. Steam Lump Coal	3.63
Best Slack	2.95
All net ton f.o.b. Toronto.	

OLD MATERIAL.

	Tor'to.	Mont'l
Copper, light	\$12 05	\$11 00
Copper, crucible	15 00	13 50
Copper, unrec'bled, heavy	13 05	12 50
Copper wire, unrec'bled..	13 05	12 50
No. 1 machine compos'n..	12 00	11 00
No. 1 comps'n turnings..	10 00	10 00
New brass clippings	9 15	9 10
No. 1 brass turnings	8 30	7 75
Heavy lead	3 25	3 25
Tea lead	3 00	2 75
Scrap zinc	4 00	3 75

Dealers' purchasing prices.

METALS.

Prices in cents per pound:

	Mont'l.	Tor'to.
Lake copper	16.25	16.25
Electrolytic copper	16.25	16.25
Spelter	6.00	6.00
Lead	4.70	5.15
Tin	50.00	51.00
Antimony	10.00	9.75
Aluminum	23.00	23.00

SMOOTH STEEL WIRE.

No. 6-9 gauge, \$2.35 base; No. 10 gauge, 6c extra; No. 11 gauge, 12 extra;

No. 12 gauge, 20c extra; No. 13 gauge, 30c extra; No. 14 gauge, 40c extra; No. 15 gauge, 55c extra; No. 16 gauge, 70c extra. Add 60c for coppering and \$2 for tinning.

Extra net per 100 lb.—Spring wire; bright soft drawn, 15c; charcoal (extra quality), \$1.25.

SHEETS.

	Mont'l.	Tor'to.
Sheets, black, No. 28....	\$2 85	\$3 00
Canada plates, ordinary, 52 sheets	2 80	3 00
Canada plates, all bright.	3 70	4 15
Apollo brand, 10¾ oz. (American)	4 30	4 20
Queen's Head, 28 B.W.G..	4 50
Fleur-de-Lis, 28 B.W.G..	4 20
Gorbal's Best Best, No. 28	4 45
Viking Metal, No. 28....	4 40

NAILS AND SPIKES.

Standard steel wire nails, base	\$2 40
Cut nails	\$2 60	2 65
Miscellaneous wire nails..	75 per cent.	
Pressed apikes, 5/8 diam., 100 lbs.	2 85

FINE STEEL WIRE.

Discount 25 per cent. List of extras. In 100-lb. lots: No. 17, \$5; No. 18, \$5.50; No. 19, \$6; No. 20, \$6.65; No. 21, \$7; No. 22, \$7.30; No. 23, \$7.65; No. 24, \$8; No. 25, \$9; No. 26, \$9.50; No. 27, \$10; No. 28, \$11; No. 29, \$12; No. 30, \$13; No. 31, \$14; No. 32, \$15; No. 33, \$16; No. 34, \$17. Extras net. Tinned wire, Nos. 17-25, \$2; Nos. 26-31, \$4; Nos. 30-34, \$6. Coppered, 75c; oiling, 10c.

MISCELLANEOUS.

	Cents
Putty, 100 lb drums	\$2.70
Red dry lead, 560 lb. caska, per cwt.	6.00
Glue, French medal, per lb	0.10
Glue, 100 flake	0.11
Tarred slaters' paper, per roll...	0.95
Motor gasoline, single bbla., gal..	24½
Benzine, per gal.	23½
Pure turpentine	64
Linseed oil, raw	58
Linseed oil, boiled	61
Plaster of Paris, per bbl.	2.10
Plumbers' Oakum, per 100 lbs....	3.25
Pure Manila rope	17

The General Market Conditions and Tendencies

This section sets forth the views and observations of men qualified to judge the outlook and with whom we are in close touch through provincial correspondents.

Montreal, May 27, 1913.—Things are looking brighter on the machine tool horizon. Optimistic handlers of big tools tell us that they are looking forward to great big business shortly. This is not dreamy stuff, but it is backed by the resolute determination of buyers to better their plants, so this special man said, and he is head of a large agency. He stated, further, that in sight were some large railway orders. This concern represents a number of the very best American firms, and when they say business is good, while all around, others are starving for some slight modicum of activity, there is a reason. Their agencies are in most cases exclusive. They represent a large punching machine company; also a planer and shaper firm and these lines are made in Canada, yet nevertheless they are selling largely and are not faking at all.

Pig Iron and Copper.

A sharp decline in pig iron has tended to check buying, but there is still some hopeful sign of activity. From the Pittsburgh district comes news of big enquiry being made by the Westinghouse Company. Low prices on steel-making iron seemed to have induced buyers to hold off for a further decline. In the

foundry trade, it is understood that consumers are anticipating a further drop in the market. The activity in cast iron pipe is occasioned by the building and municipal undertakings now going on everywhere. The output of coke has decreased, although there is some call in big centres. Copper continues irregular and dull. The early firmness of last week was replaced by a weaker tone, and small business has ensued. There has been some enquiry for electrolytic copper for June, July and August delivery; holders sticking to the higher prices because of the sympathy with the advance in London. To-day there was a break reported, and no large buying was in evidence. Exports of copper from this continent have been heavy the past week and most of the copper seems to be going to Europe, while quite goodly supplies have gone to Britain. Standard copper was less active everywhere, according to latest reports, and there was a net decline on spot. Copper sheets remain quiet.

Metals and Old Material.

The enormous activity in the steel trade has produced a great deal of scrap. There has been a slight run on old contracts and consumers are using all that

they agreed with a slight demand extra. The prices have weakened slightly as might be expected. It will be seen that big firms are using the scrap material and keeping out of the pig iron market for a longer time than usual. Tin again broke sharply this week. The trade is again unsettled, owing to freer offerings and lower prices abroad. The chances are all in favor of a further decline no change is recorded in our lists. Pig lead has steadily advanced and it quoted at five cents. Antimony is easy and unchanged. Aluminum and spelter are unchanged and uninteresting.

Toronto, May 27.—The local demand for machinery still continues firm and is indicative of gradual development in industrial circles, which augurs well for future business. From outside points the market reports show a small demand for equipment. Among implement manufactures, a number of large factories running at reduced capacities. This condition should not, however, be taken as an indication of any lack of faith in future developments, but to the ordinary conditions of local supply and demand which govern their output. There is a growing demand for electrically operated tools and motors of small size, and developments along this line will be quite a feature of the local machinery business for some time.

The Canadian Fairbanks Morse Co., Ltd., report the sale of a planer to the Polson Iron Works, Toronto, and the

following equipment to the McEnany Mines Schumacher, Ont.: One 18 x 36 x 18 lathe; one each, drill press, 6 inch pipe machine, power hack saw, and grinding machine.

Pig Iron and Steel.

The steel market, if anything, is quieter this week than last, owing of course to the state of the money market at present. This applies to all lines, practically no business being done. A prominent manufacturer of bolts and nuts in Ontario informed us to-day that business was inclined to be quiet, especially in light lines. There was a report current this week that nails would take a drop in price following a tendency that way across the border, but this was denied by a local house. In spite of poor business, prices in most lines seem to be holding up. Some structural men are giving contracts for small amounts, but on the whole this business is seriously affected by the present condition of the market. Owners who planned to go ahead, on coming up against the money proposition, do not find it so easy to do so.

Metals.

Samuel Benjamin & Co. reported no changes in prices, and add that business is low, and that on top of this, customers are asking for deferred deliveries. The Canada Metal Co. reports things quiet generally, but add that their three factories in town are kept fairly busy. Lead is strong. Copper is controlled by the money market. Aluminum is strong, but very few firms are carrying it.

MANUFACTURERS GOING EAST.

A VISIT of Ontario and Quebec manufacturers is planned to St. John and other cities in the Maritime Provinces this summer.

Mr. H. P. Timmerman, the industrial commissioner of the C. P. R., has brought the matter to the attention of the Board of Trade at St. John, and it has been decided to issue an invitation to members of Boards of Trades in a large number of cities of Ontario and Quebec, and to make arrangements to entertain them and show them round the city. The Boards of Trade at Moncton and Fredericton have expressed their willingness to co-operate.

Mr. Timmerman states that the plan is to bring the party over the C. P. R. as far as Fredericton. After a short stay in the capital, they will be taken down the St. John River, and spend a day or two in St. John. Arrangements will be made to take them to Moncton, and from there into Nova Scotia, and some of the men who have signified their willingness to take the trip will

take advantage of the opportunity to go on to Sydney and look over the developments in progress there.

NEW MERGER—STEEL PRODUCTS CANADA.

RICHARDSON & CO., brokers, Montreal, announce the purchase of the Gananoque Spring and Axle Co., Ltd., the D. F. Jones Manufacturing Co., Ltd., of Gananoque, and the Dowsley Spring and Axle Co., of Chatham, Ont.

The new merger will be operated under the name of the Steel Products of Canada, Limited, and will have a capitalization of \$2,100,000, divided as follows:—Six per cent. bonds, \$600,000; 7 per cent. preferred stock, \$750,000, and the common stock, \$750,000. It is understood that 75 per cent. of the securities in the new company has been taken in lieu of cash by the holders of stock in the amalgamated companies, and that the rest will shortly be offered to the public for subscription by Richardson & Co.

GRAPHITE CUPOLA STOPPERS.

HOW many foundrymen realize that human life and the safe flow of many tons of metal may depend upon the material and construction of the small stopper in the bottom of the steel ladle? The Joseph Dixon Crucible Co., Jersey City, N.J., have just published an attractive booklet of 30 pages devoted to a description and illustrations of plum-



bago stoppers, nozzles and sleeves. Although many illustrations of stoppers appear in this booklet they do not by any means comprise the many styles and sizes of which there are hundreds. The Dixon Company claim that owing to the grain in their plumbago stoppers which runs lengthwise and never crosswise, the stoppers are less liable to pull loose when the stopper-head freezes to the nozzle, and that the bolt holes and contour of Dixon's Stoppers are absolutely true. This booklet is well worth the reading to those who are at present using clay instead of graphite stoppers.

It should be worth much to foundrymen to know that they have lessened the danger to life and limb of their employees by providing inexpensive and more efficient safety such as the use of these graphite stoppers afford.

KOOTENAY LAKE VESSEL CONTRACTS.

Announcement that contracts had been let for a new steel car barge for Kootenay Lake, the second to be built this year, and also for a \$200,000 steel steamer and steel tug for the Okanagan Lake service, was made May 10, in Nelson, B.C., by George J. Bury, Vice-President Canadian Pacific Railway. Mr. Bury afterwards left for the east on board the recently completed steel steamer Nasookin.

WM. KENNEDY & SONS, OWEN SOUND.

WM. KENNEDY & SONS, makers of hydraulic turbines, water power plant machinery, etc., Owen Sound, Ont., have planned extensive additions to their iron and steel foundries. They are putting up a building, measuring 40 ft. by 80 ft., between the iron and steel foundries, which is to be the new iron moulding shop. Building operations will start later in the summer. The firm have already placed an order with Sheldons, Ltd., Galt, Ont., for a cupola, and will shortly be in the market for a 10-ton electric crane and two smaller cranes of 18 ft. span. Besides the above, they are putting up a new erecting shop adjacent to the present machine shop, measuring 40 ft. by 80 ft. For this they will require a 10-ton electric crane, of 38 ft. span and 21 ft. lift. Among other equipment required will be a large boring mill. They expect to increase their staff by 25 to 30 men.

A new cupola room is being erected with coke and pig iron storage, together with a hoist. In the yard it is their intention to instal a mono-rail system for moving castings and molding boxes to and fro. The Grand Trunk are putting a new siding across the road and alongside the plant. Extensions to the steel foundry are also contemplated, including a cleaner room, but nothing definite has been arrived at yet. Recently a mono-rail system inside the works was installed by W. D. Beath & Sons, Toronto.

John Saxby, of Saxby and Farmer, inventor of the system of interlocking railway points and signals, died recently at Hassocks, near Haywards Heath, England, at the age of ninety-one.

INDUSTRIAL ^A_N^D CONSTRUCTION NEWS

Establishment or Enlargement of Factories, Mills, Power Plants, Etc.; Construction of Railways, Bridges, Etc.; Municipal Undertakings; Mining News.

Engineering

Wallaceburg, Ont.—The Wallaceburg Brass & Iron Works are to make extensive additions to their plant.

Lethbridge, Alta.—The town purpose spending \$2,419 on a blacksmith shop.

Winnipeg, Man.—C. Shilling & Son, of St. Paul, Minn., have purchased a site in Elmwood, and are to erect a plant for the manufacture of stoves.

Preston, Ont.—The Dominion Bronze Mfg. Co. is to erect a new foundry here. J. W. Patterson, formerly of Newcastle, Pa., is to be superintendent.

Sydney, N.S.—The Dominion Steel & Iron Co. blast furnace No. 7 was blown in on May 22nd. This marks the completion of the program of extension undertaken three years ago.

Fort William, Ont.—The capital stock of the Maritime Nail Co., Ltd., will be increased from \$250,000 to \$3,250,000. Part of this will be used to erect a \$600,000 plant at Island No. 1, the work to be completed in August, 1914.

Saskatoon, Sask.—A company, in which Dr. F. G. Sparling and Fred Engen are interested, and which will establish a plant for manufacturing engines for plowing, harrowing and sowing at one time, has applied to the city for concessions.

Toronto, Ont.—The National Cash Register Co. have applied for permit to build a factory on Christie St., costing \$250,000, which will be two storeys high, 320 feet long and 60 feet wide. Page & Warrington are the architects, and Jackson, Lewis Co., Ltd., are the contractors.

Welland, Ont.—Arrangements are being made with the Michigan Central Railway to carry the street car lines over their tracks to convenience the Deere Co., makers of farming implements, of Dain City, who are making additions necessitating the employment of 600 more men.

Moose Jaw, Sask.—The Federal Engineering Co., Toronto, makers of milling supplies, electrical appliances, electrical stoves, etc., have had their representatives here looking for a site on which to build a distributing house for

the West. J. K. MacKeen is representing the firm.

Sapperton, B.C.—The British Columbia Brass Works have been purchased by T. W. Hartley and John Dobson, who will increase the capacity. Besides the present product, the new company will manufacture steel casements and steel sashes on the two upper storeys. Their new name will be the H. & D. Mfg. Co.

Sydney, N.S.—George Hugher, representative of the Anglo-Canadian Industrial Trust Co., of London, says with reference to putting up a plant in Sydney for steel shipbuilding: "My people are willing to organize a company with a capital of \$2,000,000 and erect a plant capable of building ships up to 10,000 tons, provided the city council or board of trade give a free site with water frontage and guarantee the interest on \$2,000,000 six per cent. preference shares. If you cannot see your way clear to do this please make a counter proposition and I will see that the same gets consideration."

Electrical

Russell, Ont.—The ratepayers recently voted in favor of the town erecting an electric light and power plant which will be gone ahead with at once.

Tillsonburg, Ont.—The Tillsonburg Electric Car Co., Ltd., have been granted a bonus by the town and will proceed to build their factory here at once.

Kindersley, Sask.—On May 29th the ratepayers will decide whether to borrow \$35,000 for the purpose of completing waterworks and electric light systems.

Rockwood, Ont.—The Township of Eramosa, Ont., has issued debentures to be applied to secure electric power from the Hydro-Electric Power Commission of Ontario.

Orillia, Ont.—The Water, Light and Power Commission are considering the purchase of 48 cluster lights at a cost of \$13,000. Engineer Greenwood is making estimates.

Medicine Hat, Alta.—By a vote of 974 to 181 the burgesses of Medicine Hat decided to grant a street railway franchise to Sir Max Aitken. The vote was the largest ever cast on a local by-law.

McAdam Junction, N.B.—Work is begun on the foundations of the new C. P. R. shops here. The shops are to be run by electric power and a large plant is to be established at McAdam Junction for that purpose.

Drumbo, Ont.—The villages of Drumbo, Plattsville, Princeton and Brighton, have voted in favor of taking power from the Hydro-Electric Commission, and the final vote of the residents will be taken on July 21st.

Kamloops, B.C.—The ratepayers have voted favorably on a proposition to spend \$100,000 to extend waterworks, \$120,000 to extend electric light system, and the balance of \$480,000 for an electric light power plant on the Barrier River.

Estevan, Sask.—The town has contracted with the Dominion Odie Electrical Co., Minneapolis, for the transfer of five acres in the industrial section, upon which the Company must erect within ninety days a completely equipped plant to manufacture their goods and employ 50 hands.

Ladysmith, B.C.—Fifty miles of new electric tramway will be built on Vancouver Island this year, with Ladysmith as the hub of the new system, according to Capt. Montague Yates, of Victoria, general manager of the new Vancouver Island Hydro-Electric and Tramway Co., which is to start active operations this month. Extensions are planned to Chemainus, Duncan, Nanoose and Nanaimo.

Water-Works

Sudbury, Ont.—The town has passed a by-law authorizing the expenditure of \$17,325 for waterworks extension.

Port Coquitlam, B.C.—On May 15th the ratepayers passed by-laws authorizing the expenditure of \$100,000 on the water works.

Brighton, Ont.—A large force of men are employed installing a waterworks system here. The first sod was turned by the Reeve.

New Westminster, B.C.—A by-law will be submitted to the ratepayers shortly, providing for the expenditure of \$45,000 on water works.

Uxbridge, Ont.—On June 19th the ratepayers will vote on a proposition to

spend \$2,000 on extending water mains and providing a pumping station.

Westmount, Que.—Residents are urging the City Council to construct a reservoir on the mountain, owing to the danger from fires caused by an inadequate water supply.

Sarnia, Ont.—Work on the new waterworks will be delayed, as to sell the town's debentures just now would mean a loss of \$20,000, owing to the stringency of the money market.

Winnipeg, Man.—Capt. Cairns, representing the Anglo-Canadian Fertilizer Co., has been given permission to erect a plant at the outlet of Clifton St. sewer to demonstrate his method.

Cardston, Alta.—The A. Cazier Construction Co., of this town, have completed arrangements and started work on a large contract for the United States reclamation service at Babb, Montana.

Bedford, Que.—The council have secured the services of a competent engineer, who has decided that the town has only one practical source of water supply, namely, Pike River. A dam and pumping station will be built.

Calgary, Alta.—Waterworks Engineer A. Ellsler Fawkes, has warned the council after a consultation with T. Aird Murray, Toronto, that it is inadvisable to establish a filtration plant on a large scale, until the question of water supply is settled.

Wood-Working

Bradford, Ont.—Mickle, Dymont & Son, a lumber firm, have decided to move their plant somewhere near Toronto.

Port Moody, B.C.—The Vancouver Timber and Trading Co. will build a lumber mill with a capacity of 200,000 ft. a day.

Centre Blissville, N.B.—A sawmill owned by Luther B. Smith was burned recently, at a loss of \$13,000. Insurance, \$12,000.

Municipal

Wingham, Ont.—The ratepayers have passed the by-law allowing \$6,500 to be spent on a stone crusher and road roller, and \$5,000 on the water works.

Richmond, Que.—The Provincial Government has informed the town council that it does not approve of the road machinery that the town propose to purchase, and has recommended several other makes.

Chesterville, Ont.—On May 31st the ratepayers in the township of Winchester will vote on a scheme to give a bonus of \$8,000 to the Ottawa and St. Lawrence Electric Railway to construct its line through the township.

Regina, Sask.—A power house and laundry at a cost of \$10,000 are planned by the city council. It will be of structural steel, reinforced concrete and brick construction. M. R. Darrack, Western Trust building, is the architect.

Saskatoon, Sask.—By-laws have been voted favorably upon by the ratepayers as follows: \$185,000 for a hospital; \$100,000 for extending street railway; \$150,000 for extending electric light and power system and \$100,000 for new traffic bridge.

Toronto, Ont.—The city has engaged experienced men to value the Toronto Street Railway and the Toronto Electric Light Co., so that the citizens will be able to vote on the proposed purchase of these utilities when the matter comes before them.

Ottawa, Ont.—The city will this year issue \$1,000,000 worth of debentures to provide for, among other things the new bacteriological laboratory, costing \$10,000; boring artesian well, \$15,000; completion of the high pressure water plant, \$35,000; changing two-phase system of electric light distribution to three-phase system, \$150,000; and to provide flush valves on water mains, \$4,000.

Kamsack, Sask.—By-laws will be submitted to the ratepayers on May 30th to authorize the expenditure of \$25,000 for installing a light and power plant; \$63,000 for a system of water works, and \$15,000 for the construction and installation of a system of sewers.

Watrous, Sask.—On June 3rd the ratepayers will vote on a scheme for spending \$35,000 on a waterworks system.

Medicine Hat, Alta.—The ratepayers have voted favorably on a proposition to spend \$223,000, on a gas system and extensions; \$85,000 on water works plant extension; \$17,000 on fire apparatus; \$170,000 on electric plants; \$116,000 for sewers; \$225,000 on water works system. They also guaranteed the bonds of the Felix Frank Co., manufacturers of car wheels, who will spend \$1,000,000 on their plant; also the Saskatchewan Bridge and Iron Co., and Leigh Hunt who will spend \$1,000,000 on a cement plant, etc. On a later date, the franchise was granted to Sir Max. Aitken, of Montreal, for a street railway system.

Windsor, Ont.—By-laws will be submitted to the people on May 31st for the purpose of obtaining permission to

loan money and make other concessions to Kemp Pittman, of Detroit, to form a company to manufacture auto springs, steel windows, friction gears and other steel products; Mels L. Olson, of Detroit, to form the Swedish Crucible Casting Co., of Canada, Ltd., to manufacture steel and other castings; to John Kelsey, Detroit, to form a company to manufacture wheels and auto parts, and to James E. Campbell, of Hepworth, Ont., to form the Vincent Steel Process Co., Ltd., to manufacture emery wheel cutters.

Hamilton, Ont.—Representatives of the Ontario Pipe Line Company waited upon Mayor Allan recently, and announced that the company was completing arrangements through which it hoped to be able to build about eighty coke ovens here on a site twenty-eight acres in extent. From these could be obtained seven and a half million feet of gas per day, and should the plan go through, and Mayor Allan says the prospects are bright, the gas problem will be solved. The company will agree to sell this gas at not more than 40 cents per thousand, and to sell all the natural gas it can get at the same figure. It is estimated that such a plant would cost about \$1,500,000.

Building Notes

Montreal, Que.—N. B. Stark & Co. are purchasing the St. George Church property for New York men, who will build a \$4,000,000 hotel, with 600 rooms, on the style of the Hotel Belmont, New York.

General Industrial

Toronto, Ont.—The Clark Mattress Co. have purchased land here on which they will build a factory.

Oakville, Ont.—The Langmuir Paint Co are considering moving their plant here, and are asking for inducements.

Calgary, Alta.—James Stewart & Co., of Chicago, will build a 5,000,000 bushel elevator here for the Canadian Malting Co.

Vienna, Ont.—The Dominion Natural Gas Co. will shortly undertake extensive development work in Vienna district, including laying of new lines.

Trenton, Ont.—The Dominion Cannery, Ltd., will operate the Lake Port Cannery Co. works this season, and erect a new plant on their old site in the Fall.

Toronto, Ont.—The Dominion Fireless Cooker Co. has been incorporated in Toronto, with a capital stock of \$40,000

and will manufacture fireless cookers and aluminum ware.

Steveston, B.C.—A plant for the manufacture of stamped metal goods is to be started here, and nickel plating is also to be carried on. Samuel Cory is organizer of the Company.

Harcourt, Ont.—The New York Graphite Co. are to erect a plant for the refining of graphite at Harcourt. It is reported that the plant will have a capacity of 50 tons of ore per day.

Bromptonville, Que.—Messrs. E. Bonrasso & Gedeon Hains are installing machinery in their brick plant. They will use steam power at present, for which electric will be substituted later.

Hamilton, Ont.—Excavation work for the \$60,000 plant to be erected by the Dunlop-Magee Co., Ltd., on East Barton Street, started last week. James Dunlop is president of the company.

Brampton, Ont.—The J. W. Hewetson Co., Ltd., Toronto, manufacturers of children's shoes, will build a plant here, costing \$40,000, employing 100 hands if the town will guarantee their bonds.

Toronto, Ont.—Industrial Buildings, Ltd., are about to erect a plant on Broadview Ave., just south of Queen Street, for the United Drug Co., Ltd., costing \$60,000, and having 85,000 square feet of floor space.

Port Coquitlam, B.C.—An ice plant with a capacity of four tons per day has just been erected east of the Coquitlam Electric Co., to cater to the ice trade during the summer. Power will be furnished by electric motors.

Estevan, Sask.—J. R. Reiman, of Chicago, has purchased eighty acres here for the purpose of installing another large brick plant. He will employ 200 men and ship 10,000,000 pressed and wire cut bricks annually.

North Vancouver, B.C.—The mayor and aldermen recently went to New Westminster to study the municipal gas plant there. They came away convinced that a municipal gas plant should be installed in North Vancouver.

Sherbrooke, Que.—The city council have passed a by-law providing a site and extensions for the Canadian Connecticut Cotton Mills Co., Ltd. This company will now build a plant costing \$200,000, including machinery.

Summerland, B.C.—The Dominion Cannery, Ltd., have voted in favor of establishing a plant here, and will operate the small cannery on the wharf this season, putting in additional machinery, and build a new plant next year.

Montreal, Que.—The Mount Royal Brick Co. are erecting a large brick plant

at Varennes, to be completed in six weeks. The company is capitalized at \$1,500,000, and among the board of directors is Robert Bickerdike, M.P.

Tofield, Alta.—Messrs. T. Heathfield, D. Hammond and W. Thomas, all of Toronto, have ordered immediate shipment of necessary machinery for a brick works here. Orders for castings required has been placed with the Tofield Foundry & Machine Shop.

Peterboro, Ont.—Extensive alterations and improvements are being made to the gas plant of the Peterboro Light and Power Co. Gas lighting will be made the main business of the company. A gas purifier house, new boilers, stacks, air fans and gas blowing machinery will be duplicated throughout the plant.

Fort William, Ont.—Arrangements have been completed by a local company and contracts signed for the erection of a 100,000 bushel elevator equipped with drying and cleaning machinery on Island No. 2. I. De Lamater is managing director, and D. L. Bole and D. A. Gordon, of Fort William, will serve on the board of directors.

Railways—Bridges

Moose Jaw, Sask.—The Moose Jaw Street Railway Co., will build this year eight miles of new track, and have placed an order for ten new cars with the Ottawa Car Co.

Battleford, Sask.—An engineer from the Department of Public Works, Regina, has inspected the sub-structure for the new Battle River track bridge. The steel is on the ground ready for erection.

Newcastle, N. B.—Foundations, Ltd., who contracted for the new bridge being built here for the Provincial Department of Public Works, have sixty men employed on the approaches to the structure.

Vancouver, B.C.—Contracts for construction of the Kettle Valley (C.P.R.) over the Hope Mountain will be awarded by July 1st. The line provides a short route to Kootenay, and is to be used by the C.P.R. and G.N.R.

Goderich, Ont.—The town council is considering the installation of a municipally owned electric railway. It is expected that storage battery cars will be used, as the projectors of the scheme do not want to erect poles and wires.

Ottawa, Ont.—It is reported that the Government will purchase the Halifax and South Western Railway, which is owned by the Canadian Northern, to give the Government a through communication from Yarmouth to Sydney, N. S.

The mileage is 375, with a main line of 245 miles.

St. Catharines, Ont.—The C.N.R. has signified its readiness to put this city on the main line of its proposed road between Toronto and Buffalo. The company will build a high level bridge across the old canal and erect a station in the centre of the city on condition that \$100,000 bonus is given.

Contracts Awarded

Bowmanville, Ont.—The Canada Foundry Co., Ltd., Toronto, will supply machinery for the pump house at a cost of \$4,680.

Fort William, Ont.—A contract for building a ear shop extension has been awarded by the C. P. R. to J. H. Simons, Winnipeg, for \$9,000.

Edmonton, Alta.—W. H. Allen, Son & Co. of Bedford, Eng., have been awarded the contract for supplying an 18,000,000-gallon low lift pump.

Stratford, Ont.—The Board of Works have awarded the contract for constructing the south end main sewer to Jacob Yundst, of Gadshill, for \$12,270.

Arnrior, Ont.—The town has awarded a contract to the Victoria Foundry Co. for a new intake pipe at \$1,475, to be delivered within two months.

Newcastle, N.B.—The Canadian Gear Works, Ltd., have let the contract for alterations and additions to their plant to E. A. Forsyth, Newcastle, N.B.

Peterboro, Ont.—The Hamilton Bridge Co. have secured the contract for steel work at the new plant of Henry Hope & Son. This firm will manufacture steel sashes.

Saskatoon, Sask.—The contract for the supply of steel for the street railway extension work was awarded to the Canadian Steel Foundries Ltd., the price being \$12,500.

Winnipeg, Man.—The Canadian Steel Pipe Co., of Winnipeg, has been awarded the contract for supplying the city of Minneapolis with 10,000 feet of 48-inch lock bar steel pipe.

Regina, Sask.—The Decarie Incinerator Co., Minneapolis, Minn., have secured the contract for an incinerator at the cost of \$64,000, the price to include the removal of the old one.

Brandon, Man.—The contract for erecting the Gordon McKay Co.'s building has been awarded to the Shepley Construction Co., Winnipeg, whose tender of \$120,000 was the lowest.

Winnipeg, Man.—The National Meter Co., Chicago, have been awarded the contract for water meters by the Board of Control. The price is \$11.75 each for half-inch meters, and \$29.25 for one inch meters.

St. Hyacinthe, Que. — Galbraith & Cote, engineering contractors, of Montreal have been awarded the contract for the construction of two steel and concrete bridges over the Yamaska River. The contract price is \$48,840.

Vancouver, B.C.—The Pacific Great Eastern Railway, which is building a line from Vancouver to Fort George has awarded a contract to Evans, Colman and Evans, of Vancouver, for fifteen thousand tons of steel rails to be delivered here between October of this year and July of next year.

Winnipeg, Man.—The C.P.R. have let contracts for the construction of three portions of the double-tracking on the main line between Revelstoke, B.C., and Taft, Alta; Watmore, and Kamloops, and Kamloops and Tranquille. The contracts were let to the Grant, Smith, and McDonnell Co., of Spokane and Vancouver.

Gananoque, Ont.—The Folding Bath Tub Co., Ltd., which was established in Gananoque several months ago, has been successful in securing a contract from the Canadian Government to supply their tubs to all stations of the North West mounted Police. This contract will mean that several thousand tubs will be supplied them during the coming summer months.

Regina, Sask.—The city has awarded the following contracts for waterworks supplies:—Contract B—Canadian Iron Corporation, 1000 Talbot Street East, St. Thomas, Ont. Contract C—Jas. Robertson & Co., 176 Pacific Avenue, Winnipeg. Contract C—Pig lead, J. A. Ashdowne Co., Bannatyne Avenue East, Winnipeg. Contract D—Drummond McCall Co., Ltd., 23 Victoria Square, Montreal.

Cayuga, Ont.—The county council have purchased a Mitchell crusher, costing \$1,000 and an elevator costing \$295, from W. H. Petrie Co., Toronto; a two-ton Scotch derrick from J. T. Hepburn, costing \$240; a steam drill, made by the Napanee Co., costing \$215; a steam hoist and boiler at \$675; a 10-ton Watrous steam roller at \$2,750 and a 40 h.p. boiler and engine at \$400. These will be used for the purpose of improving the roads in this country.

Saskatoon, Sask.—At the adjourned meeting of the City Council, last week, the Standard Construction Co., was awarded the contracts for construction of the sewer and water connection for sections 3 and 4, and Harry Welch that

for section 5. For section 3, the amount of the contract was \$91,671.89, providing the soil in which the work is to be done is ordinary soil or quicksand. For section 4, the amount was \$35,998.71 for both ordinary soil and quicksand.

Lytton, B.C.—Contracts for building the steel bridge across the Thompson River have been awarded by the Provincial Department of Public Works to the Canadian Bridge Co., Ltd., of Walkerville, Ont., for the supply of superstructure material, and to the Graff Construction Co., of Vancouver, for the sub-construction and erection of the super-structure. The steel super-structure includes one span of 250 ft. highway, two 70-ft. spans and one 50-ft. deck plate girder span. The cost of the bridge will be \$80,000. Owing to the present state of the steel market, it is not thought that the steel can be obtained before March, 1914.

Tenders

Calgary, Alta.—Tenders will be received until May 31 by the Bowness Improvement Co. for the following machinery and equipment: Two alternating current generators, two direct connected exciters, one motor driven exciter set, one six-panel switchboard, one series tungsten lighting system, transmission lines and underground cable, two vertical multi-cylinder internal combustion engines. Specifications may be obtained from T. L. Turnbull, consulting engineer, Calgary.

Montreal, Que.—Tenders have been received by the Board of Control for widening the aqueduct, both with and without boulevards. The lowest tender is that of the Cook Construction Co., Sudbury, Ont., for \$2,322,652 with boulevard, and \$2,416,562 without boulevard. The tenders opened gave the following unrevised results:

	With Boule'ds.	Without Boule'ds.
J. P. Mullarky . . .	\$2,750,952	\$2,750,952
Sir John Jackson Canada, Ltd. . . .	4,225,593	4,290,040
Oscar Daniels Co. . .	2,792,606	2,954,869
Laurin Leitch Co., Ltd.	3,268,255	3,407,564
M. P. & I. P. Davis . . .	3,260,366	3,191,557
Quinlan & Robert- son	2,621,180	2,666,487
Cook Construction Co., Ltd.	2,322,562	2,416,562
O'Brien & Doheny . . .	2,772,557	2,889,057

Marine

Windsor, Ont.—The Detroit, Ojibway, Ecorse Ferry Co. started its service be-

tween Ecorse and Sandwich last week. A new 100 ft. launch is now under construction for the company.

Quebec, Que.—On May 20th the Canadian Government hopper barge No. 1, built for the St. Lawrence, was launched from the works of Geo. T. Davis & Son, Levis, Que. It is the first of a large fleet to be built for dredging operations in the river.

Hamilton, Ont.—The Dominion Government has declined to put through a bill this session making a loan of \$3,000,000 to the city for harbor improvements. They say that the bill was not prepared in time. The Harbor Commissioners say that if it is put through next session no great injury will be done.

New Line to Montreal.—La Touraine, of the French line, reached here on May 22. This boat inaugurates a new service on the St. Lawrence, and a new connection between Canada and France. The French line expects to do a big business between Havre and Montreal, and is putting a number of fine new ships on the route. La Touraine is 550 feet in length, with a displacement of 12,368 tons, and is of 12,000 horse-power.

Trade Gossip

The Canadian Fairbanks-Morse Co., Ltd., have opened a branch office and show room at 325 Simpson Street, Fort William, Ont., with H. R. Wilkes and W. R. Vollett as representatives.

The Lumen Co., West Toronto, have broken ground for a substantial addition to their plant. The purpose of this addition is for the manufacture of Ideal Trolley Wheels, and Die Castings. The other available space will be used for the increased manufacture of brass and bronze castings.

Hillcrest Collieries Output.—Directors of the Hillcrest Collieries, at a meeting held this week, ratified a contract for the sale of the entire output of the mines for a period of five years. The contract was entered into with the Canadian Pacific Railway, which has been taking about a third of the output for some time back, and was made at a satisfactory advance in selling price.

The Browning Engineering Co., Cleveland, Ohio, has received an order from the Canadian Pacific Railroad for a 100-ton wrecking crane and an order from the Pennsylvania Steel Co. for a 75-ton wrecking crane. The Browning Co. has commenced the erection of wrecking cranes for stock, so that buyers will be able to secure prompt deliveries in-

stead of waiting three or four months until a crane can be built.

Personal

Clyde L. Huff has been engaged by the town of Athabasca, Alta., as town engineer, at a salary of \$2,000 a year.

Colin MacPhail, C.E., who has been on the engineering staff of the Dominion Iron and Steel Co. for the past three years, left Sydney recently for the West.

W. D. Murrin, of London, Eng., formerly with the London United Railway, has been appointed mechanical superintendent of the entire system of the British Columbia Electric Railway Co., succeeding Mr. S. P. Thompson, of New York, who resigned.

Wm. Raymond Smith, C.E., of Edmonton, was married on Wednesday, May 21, at London, Ont., to Margaret Laura, the eldest daughter of the Right Rev. Bishop of Huron and Mrs. Williams. The ceremony was performed by the bride's father.

George H. Tod, Manning Chambers, Toronto, who is the Canadian representative for Ashworth-Parker engines, Bennis mechanical stokers and Broadbent's cranes, capstans, etc., is making a six weeks' tour of Western Canada. Mr. Tod recently opened a Western office at 601 Union Bank Building, Winnipeg.

A. T. Enlow, has resigned his position as manager of sales of the Stark Rolling Mills Co., to become partner with the Pedlar People, Oshawa. While with the Stark Rolling Mills Co., Mr. Enlow devoted considerable time to the exploiting of Toncean Metal, an anti-corrosive sheet metal product, through the medium of the Pedlar People in the Canadian field.

C. M. Waterman, manager of the Eugene Dietzgen Co., Ltd., Toronto, is making a month's trip through Western Canada. Mr. Waterman will call on his return at his firm's Chicago factory, which is making every effort to fulfil all the requirements of the Canadian field. Mr. Dietzgen, a brother of the founder of the firm, and one of the present heads of the business, will make an extensive trip through Canada later in the season.

Henry J. Fuller, president of the Canadian Fairbanks-Morse Co., has been elected vice-president of Fairbanks-Morse & Co., whose head office is in Chicago, Ill. Mr. Fuller will have charge of the Eastern business of the Company, with headquarters in New York, but will continue as president of the Canadian Company, giving it his first

consideration and spending a large portion of his time in Canada. He will leave shortly on a trip of inspection of the branches in the West.

W. F. Graves, formerly superintendent of tracks of the Chicago City Railway Co., took up his duties last week as chief engineer of the Montreal Tramways Co. Mr. Graves began his civil engineering work with the Chicago, Rock Island and Pacific Railway in 1885. He remained with this company for five years, working in various capacities and finally gaining the title of engineer of maintenance of way of the Southwestern district for the Company. Later he went with the Missouri Pacific Railway as assistant engineer of maintenance of way, which position he held for three years. He then became connected with the South Side Elevated Railroad, of Chicago, as engineer of construction, remaining with this Company for four years. He then took up his present position as superintendent of track of the Chicago City Railway Co., and has been thus engaged the last six years. Mr. Graves is a member of the American Society of Civil Engineers, the Traffic Club of Chicago, and the Chicago Engineers' Club.

New Incorporations

The **McKee Furnace Co., Ltd.**, of St. John, N.B., have acquired the Canadian rights to the "McKee Fuel Saver;" operations to be carried on under the above name, with a capital stock of \$100,000.

Hagersville Furniture Co., Ltd., incorporated at Toronto, with \$40,000 capital, to manufacture furniture; incorporators, Athol G. Robertson, Alice Lawrie, Marie Powers, James J. Kew, Morris R. Edgar, Toronto.

Dominion Mechanic Works, Ltd., incorporated at Ottawa, with capital of \$20,000 to manufacture machinery, etc. Incorporators: Zephirin Monte, Ernest Charette, Eugene H. Godin, Joseph E. Morier, Montreal, Joseph DeLorimier, Westmount.

Macbeth-Evans Glass Co., Ltd., incorporated at Toronto, with \$40,000 capital, to manufacture glass and electric fittings; incorporators, William M. Teeter, Hugh J. Macdonald, Albert Tuckey, Henry M. Thompson, Kathleen Ryan, Toronto.

The **Dominion Clay Products Co., Ltd.**, incorporated at Toronto, with \$150,000 capital, to manufacture bricks, tiles, etc.; incorporators, Cecil W. Garthwaite, James A. Courtice, James H. Hallett, James H. Donald, Thomas E. McCracken, Toronto.

Dyer Fence & Supply Co., Ltd., incorporated at Toronto, with \$40,000 capital, to manufacture and deal in wire and iron fence posts, gates, etc.; incorporators, Edward L. Dyer, William Huth, Charles P. Huth, Maude M. Huth, Edgar Armstrong, Toronto.

Brantford Machine and Foundries, Ltd., incorporated at Toronto, with \$40,000 capital, to manufacture iron and wood-working machinery, etc.; incorporators, Herbert B. Rowell, Frederick D. Green, Carl B. Smith, William A. Hawkins, William A. Hollinrake, Brantford.

Obituary

Wm. H. Raymond, foreman of the Milton Iron Foundry, fell dead on May 21st while conversing with Charles Bain in front of the latter's blacksmith shop at Yarmouth, N.S. He was 69 years of age.

John Taylor, founder of the J. & J. Taylor Safe Works, Toronto, died at the residence of his son on May 26th. He was born in Perthshire, Scotland, in 1827, and came to Toronto when he was ten years of age.

William Irvine, assistant waterworks engineer, Parry Sound, Ont., fell dead at work on May 25th, while in temporary charge of the pump house during the absence of Mr. Murray. He was about 60 years of age.

Catalogues

The **General Fire Extinguisher Co.** of Boston have published an attractive bulletin for April in connection with the Grinnell Automatic Sprinkler.

"**Metal Statistics**" (Edition published by the American Metal Market) contains a number of new tables. Some of the old tables have been rearranged in a more comprehensive form.

"**Ozonair, Ltd., London, Eng.**, have recently published a catalogue description of their system of Pure Air Ventilation. A full description is given of the properties of ozone as a medium for purifying air and method of application of the system to buildings. Several views are shown of buildings where the Ozonair System has been installed.

"**McLain's Semi-Steel**" is the title of a pamphlet which we have received describing the McLain System for making Semi-Steel Castings. It is claimed that by this system a much closer grained casting can be obtained and foundry losses considerably reduced. Full particulars can be obtained by writing Me-

Electrically-Driven, Two High Reversing Rolling Mill*

By Andrew Lamberton

The author of this paper refers to the attention given in recent years to the economical driving of rolling-mills, and introduces in this connection particulars of a new type mill which is likely to be effective in securing highly satisfactory results. Incidentally, he draws comparisons between the advanced positions held by the United States and Germany in rolling mill practice, giving prominence to the specialization feature adopted by them, as distinct from British practice.

DURING the past few years, the attention of engineers and steel-works owners has been closely directed to the problem of the economical driving of rolling-mills, which have in the past in the majority of cases been far from satisfactory in this respect, and, although the subject is surrounded with many difficulties, very satisfactory progress has been made and the way cleared for further advance.

As was to be expected, electricity has been much in evidence, and great credit is due to those who have been pioneers in this direction, for the ingenuity they have displayed, and the large measure of success which has attended their efforts. The day, however, has not yet arrived when it can be claimed, that, by the universal adoption of electricity as the motive power for driving rolling-mills in iron and steelworks, the highest economy in running costs can be attained; and every proposed installation of such machinery would require to be most carefully considered in relation to the existing conditions, and decided upon its true merits.

Speaking generally, where steelworks are associated with blast-furnaces, and

the economical design of such plant, both as regards first cost of installation, and economical performance. The greatest difficulty is met with in dealing with the reversing mills of the two-high type, where the rolls have to be reversed at each pass, and when these mills are of a large size, the electrical plant is extremely costly, the reversing mill motors necessary being from 10,000 to 15,000 brake horse-power, due to their having to start from rest under full load at each reversal.

Considerations Arising From Adoption of Electricity.

All engineers may be said to be agreed that where rolling-mills can be driven by a constant-running motor associated with a heavy flywheel to take the peak loads of rolling, electrical driving is to be preferred, provided of course that the cost of current be low enough. Look for a moment at some of the main considerations that arise in connection with the adoption of electricity for driving bar, rail, and section rolling-mills.

For small mills, rolling light sections and bars, which can be fed to the mills by hand the three-high continuous run-

lators are therefore necessary, the three-high type of mill is not so popular, although it must be admitted that on the Continent of Europe and in America this type of mill is quite commonly used even for heavier sections. The main objections, however, are the complicated live roller tables which require to rise and fall at each pass, and the increased difficulty of manipulating the bars on these rising and falling tables. There is also the further difficulty of the exact setting of three rollers to give accurate sections, together with the manipulation of the guides and guards required in this system. These considerations have caused many steel-makers to prefer the high type of reversing mill for such heavy bars and sections, even although the driving of such mills by reversing steam-engines is less economical.

This being so, it occurred to the author that if two-high section rolling-mills could be designed so as to be capable of being driven by a continuous running electric motor, and at the same time give the necessary reversals to the bar at each pass, this would go a long way to meet the difficulties referred to,

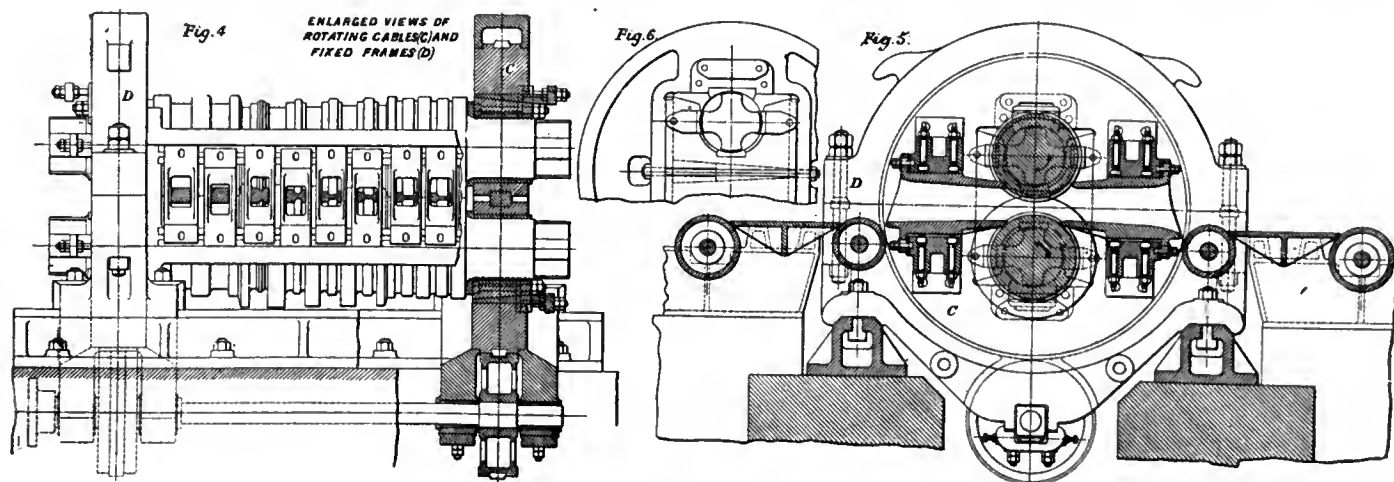

FIG. 4. ENLARGED VIEW OF ROTATING CABLES (C) AND FIXED FRAMES (D).

perhaps also cooking ovens, and an abundant supply of surplus gas is available for producing electric current at a low cost, electrical driving of such mills is clearly indicated; and the question before the engineer then becomes one of

ning mill is practically universally adopted, and in such cases the driving of these mills by a continuous-running electric motor leaves nothing to be desired. For larger mills, rolling bars and sections of heavier type which cannot be fed by hand, and where live roller feeding-tables and mechanical manipu-

as the ease of setting the rolls in the two-high mill, and the simplicity of the roller tables being fixed instead of moving, would be conserved, and the large and very costly reversing motor rendered unnecessary. The following is a short description of the method by which this is accomplished:—

*From a paper presented at the spring meeting of the Iron and Steel Institute.

Root Idea of New System.

The root idea of the new system is that, if in a mill with two rolls, arrangements can be adopted to make the bottom roll the top roll, and vice versa, then, at each reversal of the position of these rolls, there will be a pass in the opposite direction. It, then, a pair of rolls be mounted in circular gables, which are free to rotate in fixed frames

driving spindles (J), conveying the power from the mill pinions (K) to the rolls (A), are disposed in the manner shown on the drawing, and the weight of these spindles is borne up in the centre by a balanced carrying gear, the weight of the descending spindle balancing that of the ascending spindle at each reversal. It will be noted that the mill pinions are placed side by side, and

ing load, the highest economy in operation results. Fig. 4, the revolving gables with the fixed frames are shown to a larger scale, and the guides and guards for rail rolling are also shown in position.

An interesting point to observe is, that in rolling rails and sections in the ordinary type of two-high mill, it is necessary to turn the bar upside down

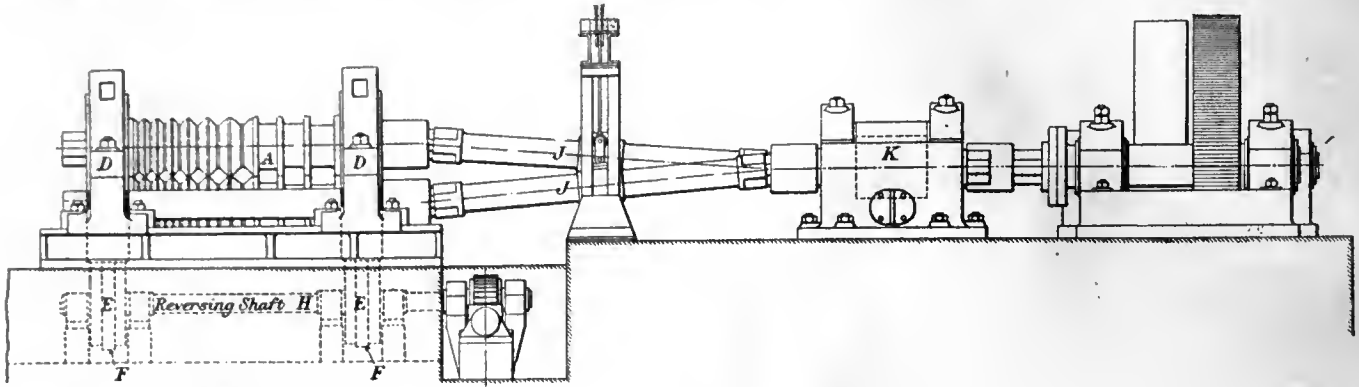

or housings, this will afford a continuous-running two-high mill, which gives reversals at each pass, on the gables being rotated through an angle of 180 deg.—Half a revolution.

Referring to Fig. 1-2-3, the rolls (A) are mounted in the usual form of chocks (B) contained in the circular gables (C), which gables are free to rotate in

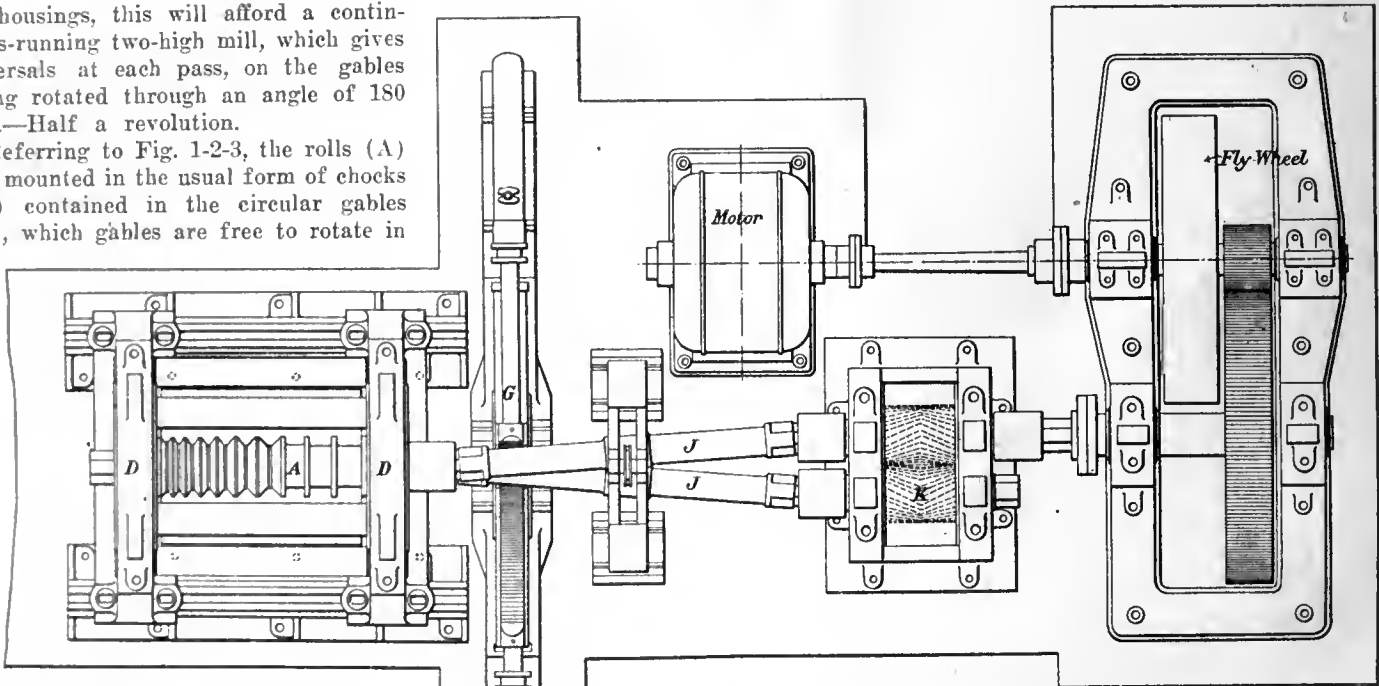

the fixed frames or housings (D). In order to make the turning of the gables easy, these are carried on broad revolving anti-friction rollers (E) placed immediately under the gables, and carrying the weight of same. These anti-friction rollers have part of their breadth formed into a spur pinion (F) which gears with corresponding teeth in the rotating gables. By means of a hydraulically-operated rack (G) gearing into pinion on the bottom roller shaft (H), the rotation of the gables is quickly effected, the time taken being only three to five seconds, while the stroke of the hydraulic rams is just sufficient to bring the rolls to their exact position at each reversal. To provide for the alternate change in the position of the top and bottom roll, the

not superposed as is usual, as this side-by-side arrangement reduces the angle on the spindles during reversals.

With regard to the motor, driving gear, and flywheel, these are so well understood as to require no description, except to observe that, by the employment of a high-speed continuous-running motor, the size and cost of such motor is reduced to a minimum, and, as the flywheel takes the peaks of the roll-

to prevent the formation of fins, but this is entirely obviated in this new design of mill, because the rolls take alternately top and bottom position, and finning is thereby corrected, so that the turning of the bar upside down is rendered unnecessary, and the operations of rolling simplified.

New System—General Layout.

In Fig. 5 is shown the general lay-out of a rail-rolling mill plant on this new system, capable of an output of 5,000 tons per week. It will be observed that three distinct mills are shown:—

- (1)—A cogging-mill taking the ingot and reducing it to a bloom.

FIGS. 1 AND 2. GENERAL ARRANGEMENT OF ELECTRICALLY DRIVEN, TWO HIGH REVERSING MILL.

- (2)—A roughing-mill to reduce this bloom to a roughly formed rail.
- (3)—A finishing-mill to finish the rail to the required section.

These mills are all of the same continuous-running reversing type, the rolls have fixed drafts, so that there is no screwing-down gear required. The live roller tables are all fixed tables of the simplest form, and the manipulation of the ingots at the cogging-mill, the blooms at the roughing-mill, and the rails at the finishing-mill, is of the simplest character. High-speed continuous-running electric motors with suitable flywheels are used to drive each of these mills, and these motors are of the most reliable type and highest efficiency: The author ventures to think that in such an installation, a very high efficiency would be obtained, with the minimum initial cost. The first mill of this new type is now in course of construction, and will be put to work in a large steelworks in England in the early summer, when the result in every-day operation will be available; and the author will be glad to give these results in a subsequent communication.

Question of Maximum Capacity.

There is, however, another side to this problem of the economical rolling of steel products, which, although it concerns the engineer less than the one just considered, is of the utmost importance to the steelworks owner, and cannot therefore be overlooked.

It is well known that to obtain the highest economy from any rolling plant, the maximum capacity of such plant must be realized, for if, in a plant of 5,000 tons capacity per week, only an average of 3,000 tons is actually obtained, the cost per ton of production on this reduced quantity would be much

the constant fluctuations in trade, in sympathy with which the demand rises and falls; and second, the fact that the total capacity of existing plants is much greater than the average demand for their products, with the result that the total quantity of the work placed is split up into numerous small orders, that rarely ever afford an opportunity for a lengthened run on the same sec-

ly outside the pale of politics that no apology is necessary in referring to it—this is "Specialization."

We are all familiar with the saying, "It is a wise farmer who looks over his neighbor's fence," and those of us who have seen the steelworks of the U. S. and Germany, could not fail to have been impressed with the constant endeavor put forth to carry out this

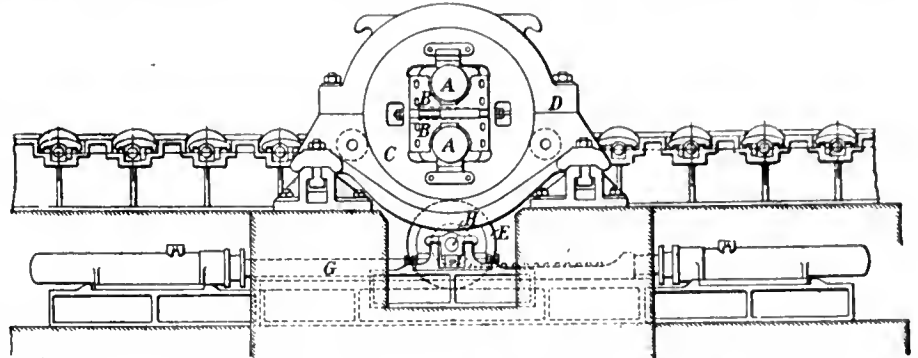

FIG. 3. END ELEVATION OF TWO HIGH REVERSING MILL.

tion, by which alone a maximum output is possible. This also results in constant changing of rolls for the different sections required, incurring large expense and very great loss of time.

Under such conditions as these, the out-put capacity of mills cannot possibly be even approximately reached, and the cost of production is thereby chronically excessive, and reacts upon, and checks, demand; so it would appear that our steel-makers seem to be within a vicious circle, where limited demand results in high cost of production, and where high cost of production again causes limited demand. This is a situation sufficiently serious to claim the earnest attention of all those directly interested. Not much comfort or satisfaction is to be got from those who will tell us that this is clearly a case of the survival of the fittest and the with-

principle of specialization to the fullest extent in all their operations; and this for the sole purpose of enabling them to produce cheaply, and consequently to keep their plant running to its fullest capacity, in the knowledge that the more they produce the cheaper they produce.

Hence, we see continuous billet rolling-mills working all the time on billets alone, and producing these in quantity far above, and at a cost far below, what can be done in Great Britain. The same principal is carried through in all their rolling operations, the orders received at headquarters being carefully classified and sent to the mills specially designed for producing the sections required, and large economies being thereby effected. In Germany, the Verband, controlling a number of the largest works, carries out this same method, and

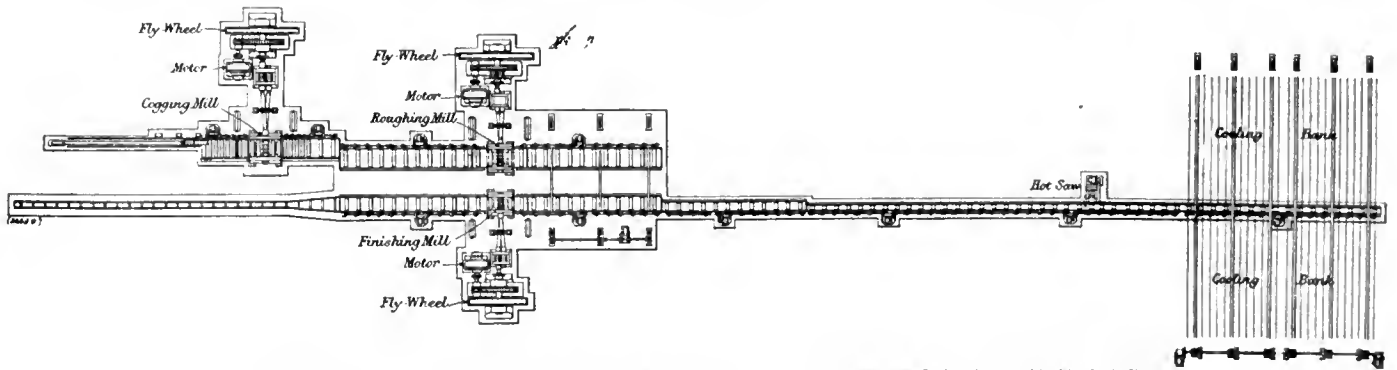

FIG. 5. GENERAL ARRANGEMENT OF ELECTRICALLY DRIVEN TWO HIGH REVERSING MILL.

higher than would have been the case had the maximum output been secured; and it is to be feared that this condition of thing is all too characteristic of the rolling-mills in this country. Let us look at some of the causes which go to explain this shortage in output.

First, and probably the greatest, are

drawal of the vanquished from the field. Is there, however, no remedy at all for such a state of matters?

Specialization of Output.

Remedies have been proposed, to which the author dare not allude in this place, but there is one which is so safe-

years of experience have now proved the great value of the system.

At the present time the steelworks all over the world are practically full of work, so that the British steel-maker is not seriously affected by American and German competition, but the inevitable ebb in the tide of prosperity is sure

to set in, and then the struggle for the share of the business of the world will certainly be keener than we have ever yet experienced. To meet this, our steelmakers will have a very serious and difficult problem to face, as the conditions in this country are admitted widely different to those in America and German.

In whatever way the matter may be dealt with, the value of this system of specialization in design of mills, and classification and selection in the work rolled in these mills, which have proved beyond doubt so beneficial wherever they have been systematically followed, cannot be ignored, and every improvement that can be devised, tending to increase efficiency and simplicity in operation of such mill plants, must constantly engage the attention of the engineer, if we are to hold our own against the very formidable opponents who so strenuously assail our position, and who enjoy advantages in regard to our markets here which are unfortunately denied us by them.

Should this new method described in this short paper prove in some degree instrumental in attaining higher economy in rolling-mill practice, or be assistant to others who may be working on this important problem, the author will feel amply compensated for any little trouble he has undertaken in this modest effort towards improvement on existing methods.

NEW N.T.R. SHOPS AT ST. MALO, P.Q.

At a meeting of the Civic Road Committee, Quebec City, on May 29, a letter was read from R. M. Leonard, Chairman of the Transcontinental Commission, which seems to determine that the site of the Transcontinental workshops will be St. Malo. The letter from Mr. Leonard to Mayor Dronin was as follows:—

"I beg to acknowledge receipt of yours of May 23, enclosing copies of resolutions passed by the City Council regarding union terminals between the Canadian Pacific and the Transcontinental Railway on the Palais site, and the construction of shops at St. Malo, and I may inform you that terms of agreement have been reached between the C.P.R. and this Commission, and approved of verbally by Mr. Chamberlain, of the G.T.R. The agreement is now being prepared, and I trust there will be no further difficulty in this matter.

"With regard to the shops, surveys and borings are now being made on the proposed site at St. Malo, and unless these borings show unsuspected difficulties, there will be no further question

regarding the location of the shops or the early construction of them. I congratulate the city on its assistance in carrying out these most difficult negotiations, as I am satisfied it will be one of the greatest benefits which your city has secured in recent years.

"The formal acceptance of these resolutions will be forwarded as soon as all questions regarding foundations, etc., have been settled, and within the date mentioned."

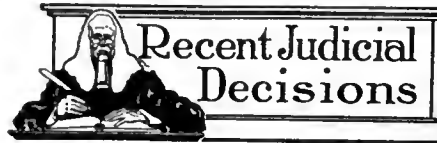

Hamilton, Ont.—Justice Middleton recently heard the action of Dick v. Standard Underground Cable Company and Hamilton Bridge Works Company for \$100,000 damages for breach of contract. The action had been pending more than a year. The plaintiff firm was engaged to erect the Standard Underground Cable Co.'s factory on North Sherman Avenue in 1910, and plaintiff claimed that the Cable Company agreed to supply the steel work and was to secure it from the Hamilton Bridge Works Co. The steel work, so it is claimed, did not arrive at the specified time, and as a result the defendant Cable Company cancelled the contract because the work was not being done according to contract. David Dick, junior president and managing director of the plaintiff company, was the first witness and was on the stand the greater part of the day. He stated that the agreement with his company and the Underground Cable Company was that the steel should be ready by July. It was not ready, and as a result the work was held up and his firm suffered great loss. He stated that the late delivery of the steel cost his firm \$10,000, because the workmen were kept on the job without producing any results. He also stated that the only money paid to his firm under the contract was a sum which had been drawn to pay the men's wages on a few occasions. He claimed that the onus was on the Cable Company to force the Bridge Company to live up to its agreement to have the steel girders ready in July. If the steel had been on the job the contract would have been fulfilled. The Bridge Company is added as a third party, in an effort to show that failure on its part to fulfil its contract with the Cable Company was responsible for the plaintiff's failure to complete the work within the specified time. R. M. Roy, manager of the Hamilton Bridge Works Company, stated on several occasions David Dick, jun., had

called on him. "He urged me to complete the contract for the Page-Hersey job at Welland, and allow the Standard Underground work to be a secondary consideration. He told me he wanted to use some of the men working at the Page-Hersey job on the Standard Underground Cable work, and it was useless to ship or fill the latter contract in preference to the Page-Hersey order. We rushed the Page-Hersey order. At one time we received a complaint from the plaintiff company that all of the steel had not been delivered, and we sent our inspector to the Standard Underground Cable plant and found it had. In some manner a column had been placed in wrong, and by turning it around our inspector showed that the shipment was O.K. Mr. Dick also told me that he could not afford to neglect the Page-Hersey job, as he had made a mistake in the Standard Underground Cable tender. Under cross-examination by J. J. Counsell, the witness said that the Bridge Company's contract was with the Standard Underground Cable Company, and not with plaintiff. He also admitted that during the summer of 1911 the shops had been closed owing to the intense heat, and also that other conditions had delayed work. He also said in answer to D. L. McCarthy, K.C., that he had no orders from the Standard Underground Cable Company to sacrifice its work and give preference to the Page-Hersey work. Witness said that if Mr. Dick had not asked for the favor he did the company would have endeavored to fill the contract with the Cable Company, which it did not do. At this point Justice Middleton stated: "I cannot understand, because a man urges to have one order completed, that he destroys his chance for suing for breach of another." A member of the drafting department of the Bridge Company stated that on one occasion Mr. Dick had offered him a bonus to rush the Page-Hersey work in preference to the Standard Underground Cable job. The case was taken en delibere.

NEW GRAIN ELEVATOR.

THE W. H. Dwyer Co., Ltd., hay and grain exporters, Montreal and Ottawa, have just completed arrangements and signed contracts for the erection of a 100,000 bushel elevator, fully equipped with drying and cleaning machinery, on the property recently purchased from Graham and Horne on Island No. 2, Fort William. Work will be pushed right ahead and the elevator should be completed in about 90 days. They are also erecting on the property a hay storage warehouse capable of storing 1,000 tons, with a dock frontage on the Kam River of 250 feet.

The Joint Feature in Foundry Pattern Construction

By Wm. J. Horner

The writer of this article is a practical patternmaker, and, as will be gathered from a study of what he has to say on the subject of Joints in Pattern Construction, it will be admitted that he has, in addition, the art of making his topic interesting and instructive. Young patternmakers, particularly, will find the article valuable.

THE patternmaker's methods of jointing differ considerably from those of the carpenter, cabinetmaker and other woodworkers. In patterns, the joints are nearly always simple, depending on screws, nails, or glue to hold them together. The mortise and tenon joint which constantly occurs in other

considered unsightly, are avoided in parts which are visible. Mitred and other joints, held together mainly or entirely by blocks glued into interior angles where they will not show, are very common in carpentry and cabinet work, but are unsuitable for patterns. Plain joints which in a pattern would be left visible are generally concealed by a moulding or a bead with a quirk or narrow groove at the side, coinciding with the joint, a thing never done in pattern construction. In heavy carpentry, bolts are often used instead of screws, but there are not many instances in pattern work where this can be done with advantage. In carpentry also there is a great deal of diagonal bracing, which even in the largest patterns is seldom possible or necessary.

There is always more than one way of jointing a pattern. The patternmaker has to decide how it shall be moulded and the best way to make it. Considerations of moulding and of pattern construction nearly always make it either desirable or essential to make the pattern of a shape not precisely like that of the casting required, the necessary modifications being made in the mould by inserting cores after the pattern is withdrawn. The shape of the pattern may thus be simplified and its strength increased.

Castings seldom have very great thicknesses of metal anywhere, and are never made in the form of open structures consisting of vertical posts and horizontal rails braeed by diagonal members in the style very common in carpentry. The patternmaker uses a large proportion of thick material, and often has to

glue up to obtain the thickness required, but this does not represent metal in the castings. It is either cored out or cut out in the wood to outlines with comparatively thin metal. If a really large bulk of solid metal were wanted in a casting, the pattern itself would seldom be made of solid wood, but material would be economized and weight saved and shrinkage avoided by boxing it up. This often has to be done when the east-

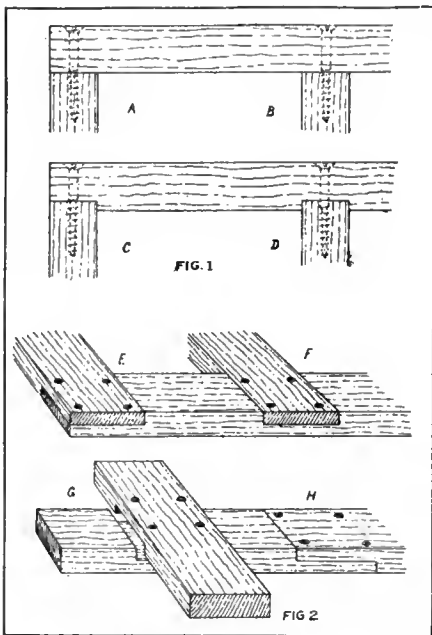

FIG. 1. EXAMPLES OF PLAIN AND REBATED JOINTS. FIG. 2. HALF LAP OR HALVED JOINT.

trades is very unusual in patterns. The half lap or halved joint is preferred. Plain butt joints held together by screws almost invariably take the place of dovetailed joints. Edge joints are seldom tongued or doweled, but are simply glued or even left slightly open to allow for swelling and shrinkage without affecting the overall dimensions of the pattern, and the pieces so joined are kept in position and prevented from warping by the attachment of other parts with grain at right angles.

Pattern Features.

Appearance is of no importance in a pattern, but accuracy in dimensions and in form, and permanence of these by building up in a way which makes warping and shrinking impossible, are the main considerations. Elaborate joints are employed in carpentry and cabinet work chiefly for appearance. The heads of screws and nails, and end grain flush, with side grain, being con-

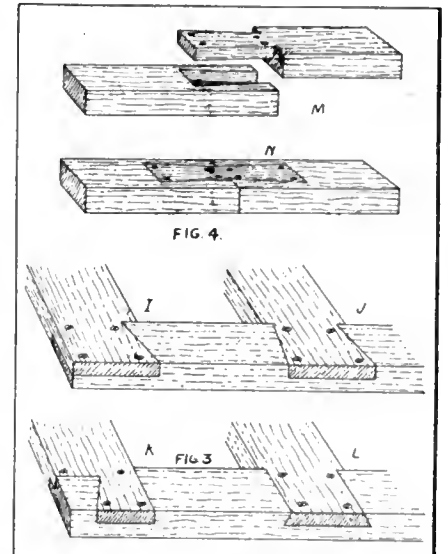
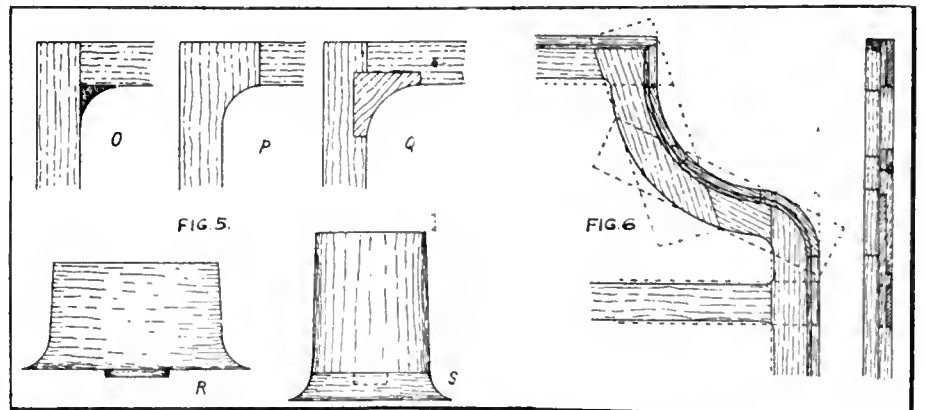

FIG. 3. DOVETAILED HALF LAPS. FIG. 4. PIECES JOINED END TO END WITH A DOVETAILED.

ing itself is hollow, but the pattern, for convenience of moulding, is equivalent to a solid one, its interior being cored. In such cases the thickness of wood in the pattern is whatever happens to be suitable, and has nothing to do with the thickness of metal in the casting.



EXAMPLES OF FILLETS OR HOLLOW.

METHOD OF BUILDING-UP FRAME WORK WHICH VARIES IN CONTOUR.

Joint Features.

The simplest and most commonly used joints in pattern work are plain butt joints held together by screws, nails or glue. Examples of these are given at (A) and (B) in Fig. 1, being joints at right angles. They may occur at any angle, however, and the surfaces joined may be large. An improvement is the rebate joint shown at (C) and (D) in the same figure, which is the joint generally used in boxing up.

Fig. 2 shows half lap joints, such as are used in the comparatively thin framework required in patterns, (E) being an ordinary corner half lap, (F) an intermediate, (G) an instance where the members cross each other, and (H) for joining pieces end to end. Sometimes half laps are made in dovetail form, as in Fig. 3 (I), being a corner joint with the dovetail inwards, which is not really of much advantage; (J) is an intermediate joint which is considerably improved by being dovetailed, and (K) is a corner joint with the dovetail outwards. This leaves a bit of rather short grain at the corner, but the joint is more secure than the example at (I). As nearly or quite half the width of the member has to be cut away in forming the dovetail, its strength has to be maintained as far as possible by forming a stepped or rebated portion as seen at the left end. This is done also in the examples at (I) and (J) when more substantial work is demanded. A dovetail in the other direction is shown at (L). It is not so often used as the other examples, but occasionally there may be circumstances which make it preferable. In all these examples 4 screws are shown, but the number may be less or more, depending on the size of the joint. Such

joints are hardly ever nailed, while glue is often used in addition to screws.

Fig. 4 shows end grain joints united by a dovetail. This is seldom employed in joining pieces of rectangular sections, because a plain half lap would generally be preferable, but it is the usual method of joining pieces of semi-circular section, either end to end or at right angles. Such joints often occur because most cylindrical work is made in halves in the pattern. At (M) the dovetail is solid on one of the pieces, and at (N) it is made separately, and the pieces to be joined are both recessed to fit.

Filletts.

Fig. 5 shows examples of filletts or hollows. These constantly occur in patterns. Most of them are made separately, going into the angle as at (O), and being generally secured by fine nails or brads. Where extra durability is required, they may be worked in the solid as at (P), either with the grain as shown, or more frequently with it running in the same direction as the fillet. When the fillet is of large radius and short in its longitudinal direction, as

the boss in place on the pattern. The boss at (R) shows a stud for this purpose. If the other part of the pattern is turned in the lathe, the hole to fit the stud would be turned also, otherwise it

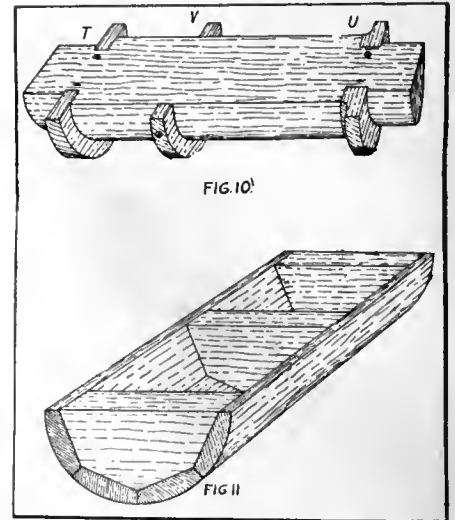

FIG. 10. METHOD OF FITTING FLANGES TO PIPES AND COLUMNS. FIG. 11. METHOD OF LAGGING-UP PIPE AND COLUMN BODIES.

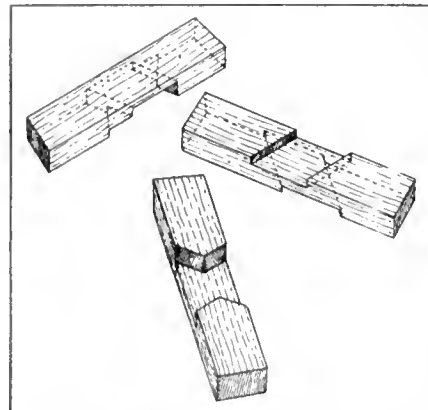

FIG. 9. METHOD OF CROSSING THE PIECES TO FORM 6 ARMS.

would be bored with a centre bit. Round prints, when more than about 1 in. diameter, are fitted to patterns similarly. Generally the stud of a print is a little longer, and is a sufficiently tight fit to hold the print without other means of attachment.

Curved Framework.

Fig. 6 shows half lap joints used in the construction of curved framework. It also shows ribs built up in segments and straight lengths. The filletts in the interior angles are cut in the solid by building up first in pieces of greater width, as seen by the dotted lines. Work of this class constantly occurs in patternmaking, as no frames, no matter how small and simple, can be cut from a single piece of wood. Short grain would make them too weak and too liable to warp.

Building Rings in Segments.

Another class of work which the patternmaker gets a great deal of is the building up of rings in segments, as in Fig. 7. The joints here are plain, but it is essential to arrange the end joints of the segments so that those of each layer overlap or break joint with those of the next. In building a ring, therefore, there must be at least two layers, and it is stronger if there are three or more. The cross sections of rings vary a great deal in shape, and are generally built so that there shall be as little waste as possible in turning them in the lathe. The layers, therefore, are not always alike in width or in radius. Very often arms have to be fitted, as in Fig. 8, and these may have to be sunk flush with one face, or more layers of segments may have to be built-on above

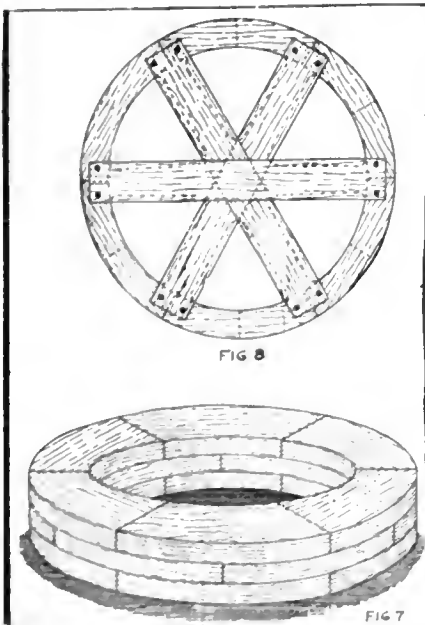

FIG. 7. RING BUILT OF SEGMENTS. FIG. 8. RING FITTED WITH ARMS.

when it occurs in thin framework, pieces may be let in, as at (Q), to avoid the weakness of feather edges. In the example at (O) the grain of the fillet runs the other way, and when the pattern is shellacked, the filletts seldom break. Leather filletts are used a great deal, and bend to any curve, while the edges cannot break. Putty is often used for curves in temporary work, and in other cases no filletts are put in the pattern, the moulder forming them in the mould.

Turned bosses usually have their filletts solid, as at (R), the thin edges being much stronger than might be supposed. In long bosses, with the grain of the wood running the other way, as at (S), the filleted portion is fitted as shown, otherwise the fillet would be too weak. The parts are kept concentric by a stud, as shown dotted, but nails or screws are used to hold them together. There would also, as a rule, be another stud on the under surface for centring

them. Six arms are usual, although more are often to be found in large wheels. Six are jointed in the centre, as shown in Fig. 9, three pieces of wood being used, and the thickness divided into thirds. This looks more complicated than it really is in practice. The angles may be marked direct on the wood by laying the arms in position over each other. The first two must fit together and leave a rebate of one-third the thickness on one face to receive the other. In cases where the arms are more numerous, they may be mitred separately without overlapping, and each one screwed to the central boss or to a special metal plate.

Fitting Flanges.

Fig. 10 shows methods of fitting flanges to pipes and columns. Usually a groove, $\frac{1}{4}$ in. or more deep, is turned in the prints at the ends to receive the flanges. Sometimes the width of the groove corresponds with the thickness of the flange, as at (T), and sometimes it includes a fillet, as at (U). Flanges which have to be adjustable in intermediate positions on the body are simply cut out to fit it, as at (V). Such work is nearly always in halves, as shown. Large pipes and columns are lagged up, as in Fig. 11, a full size cross section being marked out, and the required number of blocks cut with flats on which to nail or screw the lags.

Moulding Consideration.

Besides the joints necessary in ordinary construction, patterns often have to be jointed in a way convenient for moulding. Sometimes they have to be in halves, and sometimes parts have to be left loose so that the moulder can withdraw them from the sand separately. When they are in halves, or when they can be drawn directly away, the parts are kept in correct position by dowels which are fixed in one portion and an easy fit in holes in the other. Dowels are either of wood or metal, and while permitting the pattern parts to go together and separate easily, they must keep the parts in accurate position when together. In turned work, the central stud may take the place of dowels, or if the diameter is large or the pattern in the form of a ring, there may be a stepped or shouldered portion to keep the parts concentric. If there is any reason why the parts must be fixed in circumferential as well as in concentric relation, dowels may be used as well.

When parts have to be left loose on the sides of a pattern, dowels cannot be used, because they would prevent the parts from sliding past each other in removal from the mould. In such cases, the parts must be temporarily attached to keep them in place while the

mould is being made. They may be screwed or held by projecting wire skewers or nails. These generally have to be withdrawn before the ramming-up of the mould is completed, and at a stage when there is enough sand round the loose parts to keep them in place. In large hollow patterns, screws can be withdrawn from the interior to release parts on the exterior. Sometimes loose pieces can be held in position by a dovetail which allows them to remain behind when the pattern is being lifted out of the sand. It is made so that it cannot go beyond its correct position in one direction and taper slackens its fit as it moves in the other direction.

PULP INDUSTRY IN CANADA.

WITH the restriction of the export of pulp wood from Crown lands in Ontario, Quebec and New Brunswick about three years ago, remarkable expansion has taken place in the Canadian pulp and paper industry. Before that time, the few Canadian industries in operation scarcely made ends meet. Since that time, 19 companies have been incorporated in Quebec alone, involving a capital of \$41,709,000. To a great extent this increase is due to firms from United States establishing plants on this side of the line. In face of serious depletion in the native supply in the States there have come ever increasing demands. Hence of the 33 mills established altogether in Canada, practically all are prospering. The total production of newspaper alone per day is 1,600 tons. The United States is our chief customer, taking about 63 per cent. of this amount.

INCORPORATION IS BECOMING GENERAL.

THE great progress being made in the business life of Montreal is demonstrated very clearly by the large number of incorporations that are constantly being granted by the Secretary of State. Up-to-date commercial men are realizing more and more the immense value that a Government charter is to the conduct of any business, and in the course of a very few years every man, on starting business, will procure a charter protecting his wife and children, his private interests and his heirs, just as readily as he now buys life and fire insurance.

To meet these conditions and to provide facilities for obtaining incorporation, a firm of experts has opened up a suite of offices at 10, Bank of Toronto Chambers, where information and advice on incorporation matters can be ob-

tained. One of the members of the firm Mr. Joseph W. Richards, is well-known to many Montrealers, and Mr. J. A. Trotwood Richards, who is associated with him, has made a special and extensive study of these matters, and is an expert in every detail of the somewhat intricate incorporation procedure and organization.

LARGE ORDER FOR STEEL PIPE PENDING.

A CANADIAN order for about 100 miles of 60 in. riveted steel pipe is now pending, and, of course, Pittsburg mills are on the "qui vive" as to its destination.

This inquiry has been expected for some time and a number of other inquiries of this character, which have been held back pending the completion of financing plans, are expected to be brought out within the next month or two. In the meantime car builders are specifying heavily on car material contracts. Some gains are shown in new business in structural shapes that indicate a better tone to that end of the market. Mills are in a comfortable position as to orders at this time, and are not seeking new business. The fact that the smaller mills are not seeking premium business is taken as an indication only that they are desirous of taking new business now only for delivery some time ahead.

VISITING GREAT LAKES PORTS.

W. G. ROSS, president of the Harbor Commissioners, and M. P. Fennell, secretary of the Board, left Montreal last week end to visit various lake ports where they will go carefully into the question of grain handling facilities. The party will visit Fort William, Port Arthur, Duluth, Tiffin, Port McNicoll and other ports where grain is handled in large quantities.

Messrs. Ross and Fennell will also interview the larger grain exporters of Western Canada, with a view to having them ship their grain through Canadian ports and especially through the Port of Montreal, in preference to the American ports, which are now enjoying a large part of the Canadian business.

It is expected that as a result of this trip, a large portion of the business now going through American ports will be diverted to Canadian channels, as the only reason local officials can give for this business going to the United States is that the people of the West are not familiar with the facilities which the Canadian ports offer.

High Speed Gear Hobbing Performance and Equipment

By J. A. S.

One of the most notable advances of recent years in connection with machining processes in our engineering workshops has been the way in which the call for increased accuracy in the teeth of wheels has been met by the introduction of equipment which has revolutionized this branch of mechanical engineering. This article deals with the achievement.

IN the early days of machinery, wheels used for power transmission were, when made of iron, constructed with teeth cast solid with the supporting web or flange. At a later date, refinement was recognised as being necessary, and the teeth were moulded by means of machinery, and still later, increased smoothness in running was obtained by the process of cutting the teeth from the solid blank by means of a single tooth fly cutter. As developments in machining processes became more extensive and as specialisation became the order of the day, it was seen that an increased speed in production could be obtained by replacing the fly cutter by a circular milling cutter with machined relieved teeth so formed as to be unchanged by grinding.

Introduction of High Transmission Speeds.

For a long time this form of machine tool held the field, inasmuch as it satisfied most of the requirements as regards accuracy of operation, but within recent years there has been a further call for increased efficiency and decreased noise in the running of gear wheels, fostered largely by the introduction of high transmission speeds, and to meet this, strenuous efforts have had to be made. The reflex action of the introduction of the electric motor and the high speed internal combustion engine upon machine shop tool processes in this connection, is a most interesting subject, as well as an illustration of the complex nature of the reactions which occur in industrial operations. Due to this cause, circular milling cutters have had to give place to a very large extent to the gear hobbing machine.

Operating Principles of Gear Hobber.

Before entering upon a detailed description of any particular machine, however, it is advisable to recall the principle upon which gear hobbing machines operate. In a nutshell, it is that all wheels of the same pitch will gear with a rack of that pitch, and the hobber consists of a worm whose thread is broken up into teeth which are relieved on a backing off machine. In cutting spur wheels with a single thread hob, the hob and gear blank should be so geared together with change wheels that for every revolution of the blank, the

hob makes as many revolutions as there are teeth to be cut. In order that the parts of the thread on the hob which are at the time operating on the cut may be parallel to the axis of the wheel, the axis of the hob is set at an angle to the plane of the blank equal to that of the thread. It is also cut into the full depth of the teeth and fed in a direction parallel to the axis of the blank. Most gear hobbers operate vertically, so that their feed is in a downward direction. It will, therefore, be seen that, in profile, the hob forms a rack, and the effect on the blank is the same as if the wheel blank were rolled into a rack of the required pitch. Those portions of the metal which interfere with the rack teeth are cut away and thus the hob generates the teeth to the correct involute form.

Gear Hobber versus Milling Cutter.

In comparing the newer process with the older one, it is advisable to briefly indicate the main features in which the hobber is superior to the circular milling cutter. To start with, the shape of the tooth varies with the number of teeth in the wheel. In cutting the teeth with milling cutters, a set of eight cutters is provided to cover each pitch, but unless the number of teeth in the wheel that is being cut corresponds to one of eight numbers on which the cutter form is based, the shape of the teeth will only be approximately correct. In hobbing teeth, only one hob is required for each pitch, and it generates teeth of the correct involute shape, whatever may be the number of teeth required in the wheel. Again, it is well known that as a formed milling cutter becomes dull, the centres of the blank and cutter are forced further apart, and the depth of each tooth is slightly less than that of the preceding one. Inasmuch as the hob has many more cutting points than a formed cutter, it obviously lasts longer, and, in any case, the depth of all the teeth round the whole circumference of the wheel will be the same, the only possibility being that it may be slightly greater on the side on which the hob enters than on that on which it leaves the blank.

Another point to be born in mind is that, when the teeth are cut one at a time, local heating is sure to occur in spite of the utmost precaution in lubri-

cation; this local heating produces distortion. In addition to this, where cast iron wheels are being operated upon, any internal stresses present in the casting are set free locally and so produce further distortion. In the hobbing machine, because the teeth are generated in circles, these errors are eliminated, hence the spacing of the teeth in a hobbled wheel is more accurate than in a wheel whose teeth have been cut one at a time. Of great practical importance from the point of view of speed in machining operations is the fact that the hob has many more cutting points than a formed cutter and that it cuts continuously, there being no waste of time in reversal. Put in another way, there is inevitably a greater output per machine or per operator with the hobbing machine than with the milling machine.

It is, however, necessary, in order to be perfectly fair, to point out that there are disadvantages, in hobbing which have to be taken into consideration. It is evident that owing to the spiral twist of the cutting portion of the hob, a section of the blade normal to the axis of the blank is not an exactly true rack, hence the points of the teeth formed are to a very slight degree too thick. Moreover, although the blank is rotated continuously, the cutting is intermittent to the extent of the gap between each successive portion of the worm of the hobber, and after one tooth of the hob has taken a cut, a small piece of metal escapes before then next tooth comes into action. This explains why, by careful examination of the hobbled wheel, the sides of the teeth exhibit a set of small flats. By increasing the number of teeth in the hob the flats are made smaller, and if there were an infinite number of teeth, it would generate a smooth curve. The limits of error, however, introduced by these considerations, are so small that for practical purposes they are hardly worth consideration.

Hobbing Machine Features.

The illustrations show graphically some of the standardised sizes of modern hobbing machines, especially designed for cutting big pitches in steel at high speed. They are entirely automatic and are adapted for spur or worm gears, but not for spirals. A separate device is provided if required for cutting spirals, the swivelling slide

being also slightly modified, to enable greater hob angles to be secured. The machines can be driven either by belt or by electric motor mounted on the gear box, without alteration in the fundamental design. Where belts are used, the driving pulley runs at a constant speed, so that the maximum belt power reaches the machine even when it is working at its slowest cutting rate. The pulley being mounted on the top of the column, requires no guard and the belt can be received at any angle clear of the operator's hand. On the top of the column is a gear box, which gives four changes of spindle speed, and the feed can be altered throughout a wide range while the machine is cutting. No change wheels are employed to alter the feed, a special device to be described later being employed for this purpose.

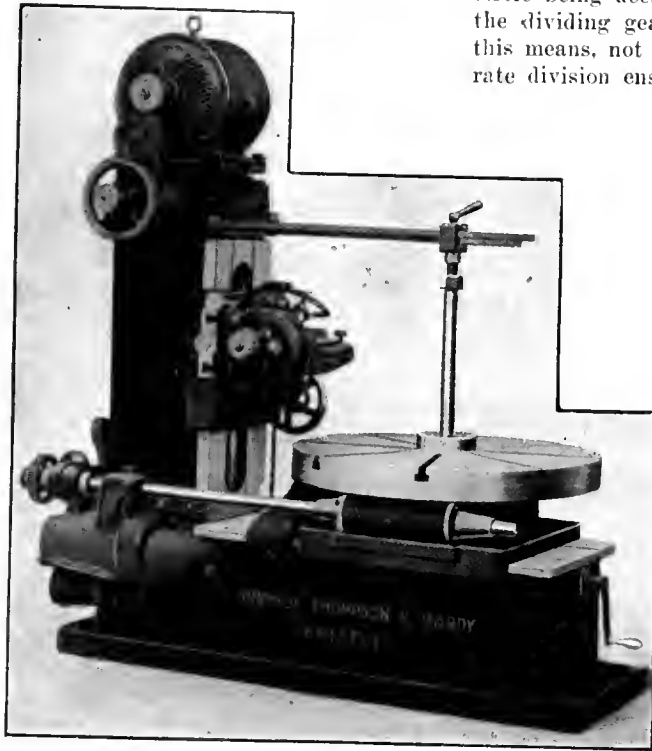

MOTOR DRIVEN GEAR HOBBER.

Both the down feed of the cutter head and the in-feed of the work table are fitted with automatic knock-offs which can be adjusted to trip to 1-1000ths of an inch. The saddles which carry the hob brackets and the revolving table run on flat slides, and the main spindles is hardened and ground internally to a taper of one in twenty. The worm which drives the table is double threaded and provided with adjustments to take up the wear. The cutter is raised and lowered by means of the hand wheel shown, and this can be accomplished while the power feed is on. The cutter head and its vertical slide are counter-weighted to reduce friction and avoid back lash, and two steady bars tie the top of the work mandril to the vertical column of the machine.

Dividing Worm and Worm Wheel.

Attention may be directed to the extreme accuracy of the dividing worm and worm wheel. The worm is made of special steel machined within a small degree of its finished size. It is then carefully case-hardened, and ground all over to a finish. Not only is the bore and the outside diameter ground, but the whole thread profile is treated in a similar manner, with the result that when the worm finally leaves the grinder, it is as accurate as is mechanically possible. The dividing wheel is as usual made in two halves, joined together by eight set screws. The holes for the connecting screws are drilled and tapped by a special attachment which is mounted on the vertical slide of the hobbing machine, the division of the screw circle being accurately accomplished by the dividing gear of the machine. By this means, not only is absolutely accurate division ensured, but the holes for

is it passed as being sufficiently accurate for the duty. All division wheels are most carefully tested at a diameter considerably exceeding that of the largest wheel, which can be cut on the machine in question, and if any inaccuracy is detected, the wheel is returned for correction to the shops.

Worm Thrust Feature.

An interesting point in connection with the design of this hobbing machine is that no ball thrusts are fitted for the worm, the pressure being taken, instead, upon the heads of the worm shaft bushes which are of bronze, and of generous dimensions. In the first experimental machines, ball thrusts were fitted in accordance with the usual practice, but it was soon found that this method was not to be relied upon

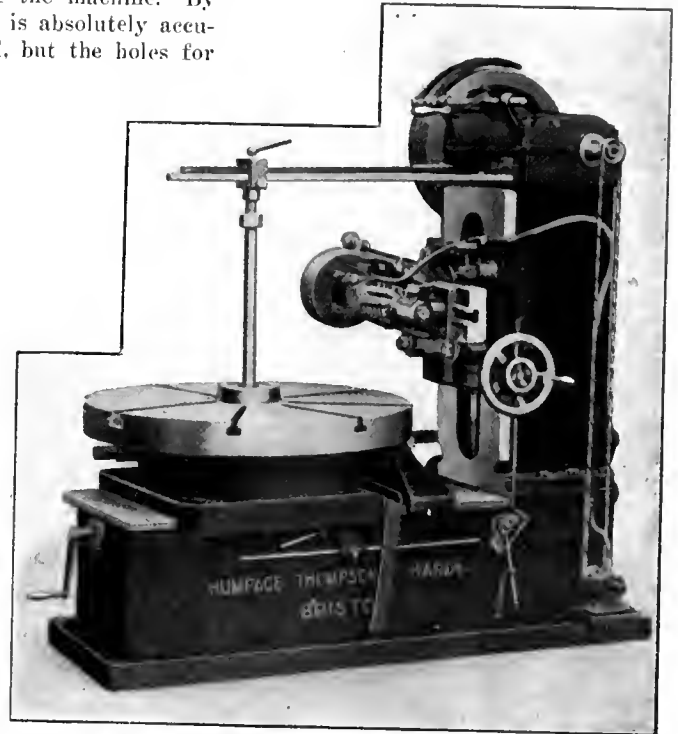

BELT DRIVEN GEAR HOBBER.

screws are also drilled and tapped in an absolutely upright manner.

After being turned and bored, the wheel is hobbled, the greatest care being exercised in the adjustment of the machine, special hobs being made and kept exclusively for the purpose. On completion of this preliminary hobbing, the two halves of the wheel are separated, and one part is revolved through 90 degrees with respect to the other. The screws are then re-inserted, and the wheel is re-hobbed. After this process, the wheel is again taken apart and the two halves once more relatively revolved through 90 degrees and hobbled again. This process is repeated until the wheel has been hobbled eight times, each time with the two halves at different relative positions, and not until this is done

even for short periods; consequently the flat thrusts described were fitted and have given perfect satisfaction. The worm runs in a bath of special oil which is distributed by the threads to the wheel and thrusts. Even after long periods of constant use, no lateral slackness can be detected in this worm. Absolutely no back lash is allowed between the worm and wheel, and provision is made for setting the worm up into the wheel as occasion requires, although it is found in practice that owing to the extreme accuracy of the thread and wheel teeth, and the efficient lubrication provided, the necessity for re-setting is extremely rare.

Work Table.

The bedplate, slides, saddle and work table are of massive proportions, and a

similarly ample margin is allowed throughout the whole of the design which undoubtedly accounts, in a very large degree, for the extremely heavy cuts which are commonly taken upon these machines. The work table in particular is worthy of notice, its depth being specially so. It has been found that a shallow or low table is quite liable to spring the work when bolting thereon, and this naturally results in producing a wheel which, although true so long as it remains attached to the table, springs out of truth immediately the fixing bolts are released. In the machines under consideration, care has been taken by stiffening the table as described, to render faults from this cause quite unknown. For the intermediate sizes of machine, an extension table is provided which takes the form of a ring accurately fitted and seated round the periphery of the main table, being secured to the main table by means of specially arranged screw dowels. An effective means is provided of locking the saddle when spur wheels are being cut so as to prevent any slackening back.

The Vertical Slide.

The vertical slide which carries the swivelling slide and hob mandril brace-

ises the production of other portions of the machine is manifested in the assembling of this important part. The slide is operated by a vertical screw of large diameter, which is driven by a system of bevel wheels from the feed gear box on the side of the bed. All wheels throughout the machine are made of especially hard steel and are machine cut with ample pitch and face. No attempt to save expense by cutting down the diameter of the wheel is made, inasmuch as it is judged better practice to employ the largest possible number of teeth. The effect of this procedure is to secure smooth running in the transmission, and freedom from chatter or jar.

In the larger sizes, where the important shafts are relatively long, the material used is a specially stiff quality of chromo nickel steel by which means all spring in the transmission is practically eliminated. The master mandril which receives the hob mandrils is accurately ground to size and runs in closely fitting bronze bushes. Provision is made for lateral take up. The weight of the assembled vertical slide is in all machines counter-balanced by a weight concealed in the column. By a double purchase suspension, the necessary mass of the counter-weight is only half that

and also there is complete avoidance of danger to the operator, should the suspension by any chance break. In the larger sized machines, the traversing of the vertical slide for setting purposes and so forth is accomplished under power from the gear box.

The hobs provided are as accurately turned out as the machine itself. Several years ago it was pointed out by Mr. Thomas Humpage, who is chiefly responsible for the design of the machines here described, in a paper read before the Society of Mechanical Engineers, that a hob which was absolutely accurate, when sent to the hardening furnace, was in practically every case liable to considerable distortion in hardening. This error was due to a permanent contraction or expansion in the material of which the hob was constructed, caused by the hardening process. Unfortunately, with the steel then available, it was found impossible to predict the amount of this error, and moreover it could not safely be foretold whether the pitch of the finished hob would be under or over the standard size. The remedy suggested by Mr. Humpage was a final grinding of the profile of the hob teeth. This method was found in practice to be not only very expensive, but also unsatisfactory in other ways. At that time, however, it was the only known process by which reasonably correct hobs could be produced. Since then, however, much progress has been made in the standardization of machine tools, together with the production of material of uniform quality; and also in the hardening process and the plant employed together with the accurate measurement of the furnace temperatures. It is therefore, possible at the present day to foretell, within very close limits of accuracy, the amount of permanent distortion which will be found in the hardened hob, and, consequently, it is the practice of the manufacturer of modern hobs of the first quality, to machine the hob with an increased or decreased pitch, as the case may be, this being accomplished by a special integrating attachment fitted to the lead screw of the backing-off machine. By this means, the resulting hob is found to be quite inaccurate before hardening, but the error after hardening is entirely negligible.

It is hardly necessary to point out that the great success which the hobbing process has met with at the present time is very largely, if not entirely, due to improvements in the manufacture of accurate hobs on the lines described above. The necessity for extreme accuracy of workmanship in this class of machine has long been realised, and the methods for securing correct division and similar points had been understood

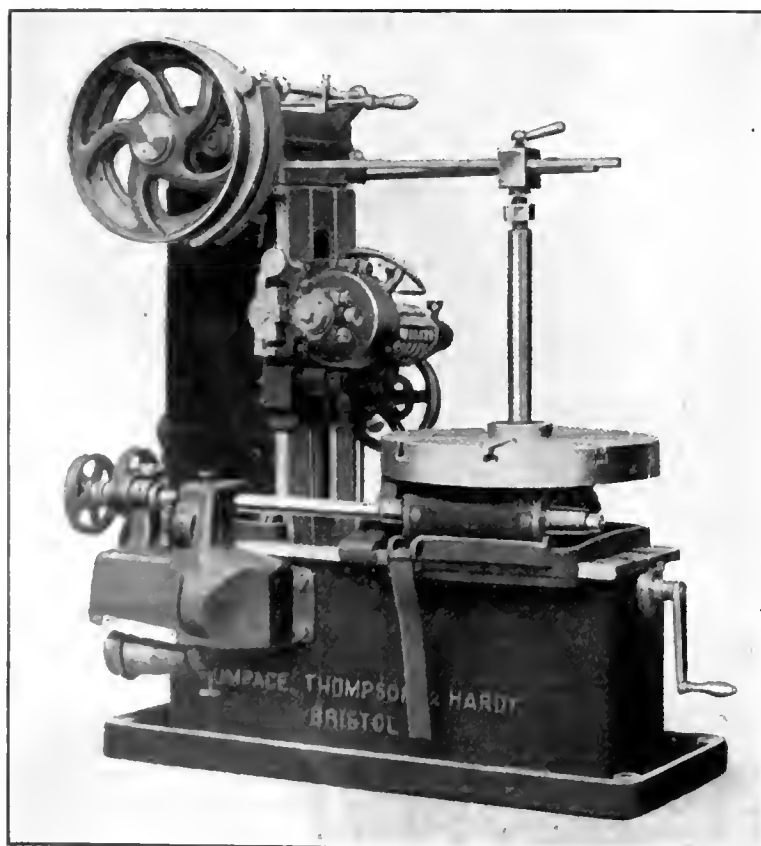

BELT DRIVEN GEAR HOBBER.

kets, is also of very generous proportions with ample bearing upon the slide ways on the face of the column. The same extreme accuracy which character-

of the slide, and hence it can be easily accommodated in the interior of the column as described. An advantage of this is, that a neat design is secured,

even in the early days of wheel cutters. The difficulties, however, attending the production of true hobs have only been realised recently.

Re-chucking Hob for Final Grinding.

One other point in the manufacture of hobs may be mentioned, because seldom recognised, although failure to do so absolutely prohibits the production of accurate work. It is of course necessary, after hardening has taken place, to remount the hob in the grinder and to take a final cut out of the hole and off the end faces. Unless great care is exercised in re-chucking the hob for this final boring and facing, it is quite an easy matter to have the hob running quite true at one end, but slightly eccentrically at the other. If the final cut be bored out under these conditions, it is obvious that, when the hob is placed in the machine mandril, it will run just as much out of truth as it did in the grinder, and although this error may be so slight as to escape observation, it will be found that, when hobbing commences, certain teeth begin to cut before the others.

For a long time it was thought that this error was negligible, or that if it must be taken into account, it might be remedied by regrinding the tops of the hob teeth on its own mandril. It was, however, found that hobs in which this error was present, never produced accurate wheels, the pitch always varying round the circumference, while, in addition, mysterious flats and inequalities occurred in places upon the finished tooth profile. It was discovered that in a hob of this description the thread angle was constantly varying as the hob rotated, a regular cycle being performed.

Suppose, for example, that the revolution started with the angle correct. As rotation proceeds, the angle would increase to a maximum, and then decrease until it was again correct. Further rotation would cause a further decrease to the minimum angle, which would be followed by an increase once more to the correct amount. The result thus obtained was obviously that described above, and the remedy is an absolutely accurate re-chucking of the hob for the final cut on the grinder.

The Change Speed Gear, etc.

An interesting point in connection with the series of machines being discussed is the change speed gear, which gives four changes of speed, with a constant torque always maintained from the belt to the hobbing cutter. Another interesting feature is the differential feed gear, which consists of two taper cones and a belt which can be shifted by a fork moved by means of a screw. The difference given by the cone is mul-

tiplied by an epicyclic gear, thus giving a wide range of feeds from 5 to 130 thousandths inch per revolution of the blank which is being cut.

As already stated, the machine is provided with a most efficient and simple knock-off arrangement by which the feed may be stopped at any predetermined point. Movable stops are fitted both on the vertical slide and the saddle, which operate a spring tripped lever at the side of the machine. This lever in turn actuates a clutch in the feed train which instantaneously throws it out of action. The stop on the saddle is used when cutting worm wheels, and that on the vertical slide when cutting spur wheels.

When cutting steel, the hob is supplied with a liberal stream of soap-water which is circulated by the small suds pump shown in the illustration. A large suds tray is provided all round the bed plate, and a reservoir is arranged inside the walls of the latter, which communicates with the surrounding tray. A similar tray is provided on the saddle with spouts and drip bars which lead the suds back into the lower tray. All parts immediately exposed to the cuttings are efficiently protected, and ample guarding of the moving parts is also well studied.

Where electric drive is adopted, it will be seen that perfect control is obtained with a completely self-contained machine, and there is an absolutely steady drive on the hob. The result of some actual tests which have been made with regard to the performance of these hobbors, not by the manufacturers, but by an independent firm will be of interest in this connection and are given herewith:—

ber of times before the hob is spoilt. Since the possible number of grinds is small if the original price of the hob is divided by the maximum number of grinds, it will be found that grinding is really a very expensive process. When a hob is used for heavy cuts, particularly in steel, it will be found that one hob tooth becomes blunt very much sooner than the others, and, consequently, unless the hob can be moved bodily in the direction of its axis it will require regrinding very quickly, and solely on account of one blunt tooth.

To obviate the necessity for regrinding, the swivelling slide is made exceptionally long to allow of ample lateral shifting of the hobs, screw adjustment and setting gauge being provided. The makers' practice is, as soon as the critical tooth becomes blunt, to work the hob along its axis by the means described, so as to bring the next tooth on the same thread, but in the next row central with the wheel which is being cut. The effect is to alter the active portion of each tooth profile, and so to practically present a resharpened hob to the work. Since there are usually ten rows of teeth in the hob, the average life of the latter is by this method increased to ten times that which it would have, without the adjustment described.

From the above description and discussion of hobbors, it will be seen that very great care and consideration has been paid by machine tool manufacturers to the development of this latest form of gear tooth production, and it is therefore thought that a resumé of such progress will not be without interest to readers of Canadian Machin-

Material.	No. of Teeth	Pitch.	Face In Inches.	Time for setting up.		Time for cutting.	
				Hrs.	Mins.	Hrs.	Mins.
Cast iron	72	3	5	30	3	0	0
Cast iron	82	3	3	30	2	0	0
Cast iron (hard)	82	3	3	30	2	30	0
Cast iron	86	3	4	30	2	45	0
Cast iron	62	4	5.5	30	3	0	0
Cast iron	69	4	2	30	1	30	0
Cast iron	84	4	2	30	1	30	0
Cast iron	100	4	2	30	2	0	0
Steel wrought, 4 carb.	13	3	3.25	10	1	50	0
Steel	13	3	6	20	1	15	0
Steel wrought	14	3	3	30	1	45	0
Steel carb.	14	3	6.5	45	1	15	0
Steel carb.	16	3	2.75	15	1	0	0
Steel wrought	19	3	3	30	1	0	0
Steel wrought	21	3	3	30	1	0	0
Steel wrought	40	3	3	15	2	0	0
Steel wrought	54	3	5	20	3	0	0
Steel wrought	72	3	3	15	2	45	0
Steel wrought	93	3	3	30	3	15	0
Steel	15	4	2.125	30	1	0	0
Steel	18	4	3	15	1	15	0
Steel cast	44	4	6	30	3	0	0
Steel cast	68	4	2.5	30	2	0	0
Steel carb.	68	4	7.5	30	6	15	0
Steel wrought	80	4	2.5	30	2	0	0

Grinding of Hobs.

In conclusion, it may be pointed out that it is a fact well known to users of hobs that the amount of grinding to which a hob can be subjected is strictly limited; that is to say, it is only possible to grind the teeth a limited num-

ery.—Humpage, Thompson & Hardy, Bristol, England, are makers of the machines illustrated.



F. J. Anderson has been appointed city engineer of Niagara Falls, Ont.

Time Study a Basic Principle of Scientific Management*

By Sanford E. Thomson**

The author of this paper refers to the erroneous views so prevalent concerning "time study" in our workshops and factories, and in addition to explaining when and how it should be directed, makes abundantly clear that enhanced returns accrue to both employer and employee as a result of its proper application.

THE primary object of scientific methods of management is to increase the productive capacity of a man or of a machine, to reduce eventually the cost of the product to the consumer, and at the same time to increase the remuneration of the worker. This must not be accomplished by mere speeding up. It must be done by so arranging the work of the man as to eliminate the unnecessary operation and waste time, and teach him to perform each necessary operation in the best manner possible. It must be done by standardizing the running of the machine so as to fit each one, as regards speed, accuracy and constancy of operation, for the particular work it has to do.

The primary defect in the common types of management, however comprehensive they may be as regards organization, lies in the lack of application of scientific methods—the lack of methods which start at the bottom and thoroughly study each element in the process, and then finally adopt a comprehensive plan of management which will consider all the details and all the processes in the plant to produce one effective working combination, with the functions of each individual definitely designated.

This scientific method, the method of starting at the bottom, analyzing operations and standardizing all implements and machines, is difficult, it is slow, it is costly at the beginning. The problem to consider, then, is whether in the end it will produce permanent results that will pay in the long run better than day work or piece work or the premium plan as commonly employed.

Fixing Piece-Work Rates.

Let us contrast for a moment the usual plan of fixing piece rates with the time study method. The foreman and superintendent get together, look over records and compare cost records of past performances, and then guess at the speed at which they think a man ought to do the job. In probably 99 cases out of 100 this guess will be wrong. If the rate is too low, the men will fail to earn usual day wages, and a strike is probable. If, as is more apt to be the case, the rates are too high, the men soon speed up and earn more than the

management think they are entitled to. Immediately, the rate is cut and the same operation is repeated. After one or two transactions of this kind, the men see that it is useless to try to earn a big wage, and, when a new rate is set, they fix among themselves a definite output per day that will give them the highest wage that the management will pay. This is no mere theory, but is almost universal practice in piecework shops.

How, then, do methods of scientific time study for rate-fixing differ in principle from the ordinary plan of comparing cost records? The taking of records, the finding how long it has taken a man or a woman to do a certain piece of work, is as old as the hills. Records of outputs on the various machines are given in every factory. The obtaining of such records, however, is not time study.

Application of Time Study.

Let us take for an illustration the making and erecting of forms or molds for reinforced concrete buildings—the forms into which the semi-liquid concrete is poured in order to mold it to the proper dimensions for columns, beams and slabs. The cost of forms is ordinarily figured either in terms of per cubic yard of concrete or else in terms of per square foot of surface area. Neither method is accurate. Take one of the simplest processes, the making up of a side for a column form. The side of a column form consists simply of a panel made up of lengths of boards or plank with wooden cleats nailed across them at intervals. The cleats are placed upon the work-bench, the boards or planks are placed across the cleats and nails are driven to fasten the cleats to the boards.

Suppose in one case we have a form or panel for one side of a column 12 in. square. Suppose in another case we have a similar form for a column 24 in. square. How shall we determine the difference in cost? Based on terms of the cubic yards of concrete in the column, the cost of the form for the 24-in. column should be four times as much as for the 12-in. Based on surface area, the cost for the 24-in. should be twice that of the 12-in. As a matter of fact, the time of the 24-in. would be only a little over one-third more than 12 in.

for making up, with even a less difference than this for the other operation of setting up and removing. Other parts of the work will be governed by still different ratios, so different, in fact, that it is absolutely impossible to figure accurate costs or set tasks by any system of cost records.

Time study does it in this way. It takes the times of the elementary or unit operations of the man who makes the form. It finds out how long it takes him to place one cleat on the bench. It finds how long it takes to place the finished form on the pile. It finds how long it takes to put a single board or plank on the bench. It finds out how long it takes him to drive one nail. By taking a lot of observations on each unit and allowing a definite fixed percentage for the necessary rest it is possible from such unit observation as these to determine the time, and therefore the cost, for making up forms of any shape and size. If a certain form has more cleats, the unit time per cleat must simply be multiplied by the extra number. If more individual boards, the time per board by a different number of boards. If more nails, the time per nail by a different number of nails. By such processes as these it has been found possible to make up accurate tables for time and costs of forms of all lengths and sizes and shapes. By the other method of overall times, a separate observation would have had to be made on every different length, width, type and design. Records on one job would have been absolutely worthless for another or even for the same job under different conditions.

Value of Time Studies.

The same principles apply to other classes of work in the shop or in construction. The time study not only shows the time in which the work should be done, but it also assists in standardizing the methods and the implements. In connection with the making of forms, for example, it was found by time study that a certain type of hammer was better than any other. It was found that a certain method of erecting the forms was considerably cheaper than any other plan. It was found that the number and size of nails, which ordinarily varied with each individual carpenter, could be fixed by definite standards to

*Abstract of paper read at the recent conference of the Western Economic Society, Chicago.

**Consulting Engineer, Boston.

avoid waste in time and materials. It was found that there were certain methods of handling the lumber which were cheaper than any other way. It was shown by actual figures the saving that could be accomplished by furnishing laborers to do all of the heavy work so that the carpenters could stick to their job of carpentry.

This has been chosen as a typical case. It is always found, even in such simple work as carpentry, when time studies are made and the work is thoroughly analyzed, that processes are improved and waste of time and of material is prevented.

Time Studies Involve Expense.

Such studies are expensive, so far as the obtaining of original data is concerned. Remember one thing, however; once the data are obtained, the unit times and the standards are adapted not only for that one piece of work, not only for that one locality, but for all processes, anywhere, involving the units observed. You will doubtless agree with me that ordinary over-all records taken in any one shop are absolutely useless for another shop. In time study work, it is entirely different, and we have instances of data taken in Philadelphia on the manufacture of one type of machinery being used in Boston for the manufacture of an entirely different type of machinery. While the work was entirely different, the same units were used in the processes. The collection of such data, therefore, in the various trades will eventually prove of universal value.

The most important function of time study, as has been implied, is settling tasks or fixing piece rates. Time study is useful also for making more exact estimates. It is useful for standardizing implements and machines. It is useful for arranging a gang of men. In a recent civil service examination for a \$4,000 engineering position, one of the questions asked involved the general principle in laying out a gang of men and horses for hauling earth from a bank to a distance of 1,000 ft. Out of 17 applicants, less than half appreciated the most elementary principle that the number of men loading carts must be governed by the time required for the carts to make the trip to and from the dump.

Universal Application.

I wonder how many men who have given attention to this matter are thinking to themselves. "This is all very well for some kinds of work. It is all right for simple work, such as form making, but cannot be done in the work with which I am connected." It is almost amusing, if it were not so serious, to hear some such remark as this repeated over and over again by men in all

classes of work with which we come in contact. The most practical answer lies in the fact that time studies have been made, and task work or scientific piece or task work has actually been introduced in so many classes of work that it is possible to state without question that it is of universal application.

Not long ago I attended a conference where the subject of one paper was the limitations of scientific management. The idea was expressed by the writer (who evidently had never come in close contact with the system) that it was applicable to many classes of work, but it was out of the question to apply tasks to the miscellaneous operations in the machine shop. Unfortunately for the reader of the paper, another speaker on the programme was the president of a large machine shop, manufacturing not merely standard tools, but making up miscellaneous orders. He stated that in his shop scientific methods of management had prevented failure during the hard times of 1907, had greatly increased output, and at the same time had reduced the number of men.

Experience in scientific methods of management has shown positively not only that quality is not reduced, but that it is improved. As a matter of fact, tasks, if properly handled, provide a means for regulating not merely the quantity but also the quality of output. In many classes of work, the saving of material is of much greater importance than the saving of time. In such cases, the worker is paid a bonus not simply for time but for quality. In fact, the largest proportion of the bonus is based on the saving of material.

Planning of Work.

While time study is one of the fundamental principles involved in scientific management and the other processes of management are centered to a considerable extent around the operation of tasks, in the sequence of the introduction of the new management, the setting of tasks is one of the last rather than the first of the operations to perform.

If a manufacturer wishes to take steps to increase his output, he naturally turns first to the consideration of the speed of the operative. How can I get more work out of my men? How can I determine in a scientific manner the amount of work they ought to do in a given time? How can I set the tasks or piece rates that will be fair? These are ultimate aims of a perfected organization, but instead of indicating the first thing to be done they represent nearly the last. If you begin to set tasks without first getting your machines and your men and your methods of handling your materials into shape you will fail absolutely in accomplishing anything but the most superficial

results. It is just here that the scientific method differs most from the rule of thumb method.

The planning of work is necessary in order that time shall not be wasted by the workers in ineffective effort. The routing must be carried a high degree of excellence in order to distribute the materials properly and permit the setting of individual tasks. The worker must be trained to accomplish properly his task.

Turning to the matter of time study when the plant is ready for it, the first thing that must be done, having obtained the necessary stop watch and blanks for recording observations, is to analyze the operations. A decision must be made as to the element or units into which each operation must be divided. In the case of form making, for example, the units were placing cleat, placing board, driving nail, placing form on pile, together with certain others of less importance not mentioned. The sequence of operations must be determined so that the times can be readily entered. The time study man must really learn each trade he observes. Preferably he should be chosen from the plant organization, since it is of much advantage for him to be familiar with the processes. On the other hand, a really expert time study man, because of his power of analysis and of seeing the operations that are taking place, can handle any kind of work, and in a very short time will know more of details than the manufacturer himself, simply because it is his job to watch each individual operation.

Standardization of implements and machines must proceed hand in hand with the time study. For example, even in such simple work as handling earth, the proper capacity of the cart or a wheelbarrow must be determined, the size of shovel fixed, and so on. As a matter of fact, this standardization even in simple matters is much more intricate than one would think.

Time Study Observation Plan.

With regard to the process to be followed in observations, the actual time study is best made by taking a record of every operation which a man performs, including not merely the effective work, but the ineffective work and the lost time. The stop watch is started, and the time he completes every operation, including the ineffective ones, is noted on the note sheets. Then, afterwards, the results are studied, and the operations tabulated and analyzed to see how long it takes to do the individual elements.

In making time study, the selection of the operative to observe is a very important point. Always select the best workers on the job for your principal

observation. Even if the supply of labor is so small that it is impossible to limit the employment in a particular branch, to men or women who are first-class operatives, relegating the others to some of the places which they are better fitted to fill, the best workers should be selected, because they work steadier and their operations are more uniform. Also, the best workers are apt to use the best methods of doing the work and will adopt new suggestions more readily. Observations taken on the best workers do not necessarily mean that these times can be used only for this class. A percentage has to be added to the net times in any case. By properly adjusting this percentage, the rates may be applied either to average workers operating at a fair speed or to first-class workers. It is usually a good plan to give the operative you observe a special incentive, such as an addition of 50 per cent. to his or her pay on the day of the observation as a reward for the trouble you are causing him.

Combining the Data.

Having obtained the time of each of the units or elements by a large number of observations on the operatives selected, we are ready to make combinations of these unit times, so as to obtain the total required time for any operation containing these units. It is frequently convenient to make these combinations by means of a simple formula. For example, taking the making up of the side of a column form, which has already been described, if we let

- c = time placing cleat
- b = time placing board
- n = time driving nail
- p = time lifting pile

then assuming 6 cleats, 2 boards and 24 nails, the formula would be

$$6c + 2b + 24n + p$$

If seven cleats are used, the 6 in the first term would be changed to 7; if three boards are used, the 2b would be changed to 3b, and so on. In practice, when task work is really started, these formulas are used to make up permanent tables, showing the total times for all the combinations that are apt to occur.

The Wage Rate Feature.

A percentage always must be added to the observed times before using them to set tasks, to provide for necessary lost time and delay occurring throughout the day. In certain kinds of work 30 per cent. is a correct value for this. The per cent. to add is governed by the character of the work and whether machine or hand labor. To fix the length of the task, the time thus obtained may now be used directly. If the operative accomplishes the task in this time, he is given his regular day wage for the

period plus a substantial bonus. If he does not complete it in the given time, he receives his regular pay without the bonus. If the data are to be used for setting scientific piece rates or premiums, the plan to be followed is somewhat different but the general principle is the same.

In determining the amount of bonus, bear in mind a fundamental law of Mr. Taylor's that a man will not do a maximum day's work for an ordinary day's pay. In order to work at the best speed consistent with physical well-being, an operative must receive from 25 to 75 per cent. higher pay than his ordinary day wages. To provide for required quality of the work, it is necessary, as I have already said, to adjust the bonus so that a man's payment will depend not simply on output, but also on the quality of the product or the amount of material used.

Essentials to be Observed.

In starting any form of piece work or task work, an essential is to begin with one operative. Get this one well started and making his or her bonus, before setting another to work. If a number of workers are started at the same time, one or more of them are certain to fall down and fail to accomplish their task in the set time. This immediately gives an opportunity for dissatisfaction. The man or woman selected for the start should be one of the best in the department. He or she should be especially instructed just how to do the work, so that there can be no possible delay in handling the materials, and so that the operation will be accomplished with the fewest motions and by the best methods.

In beginning tasks on a certain line of work, it is frequently advisable to give a longer time than will be adopted permanently, provided, however, it is clearly stated to the operatives that this is simply temporary so as to enable them to become accustomed to the new methods and provided it is also clearly stated that at a certain fixed period, the rates will be changed to new definitely stated figures. These permanent figures must be given out before tasks are begun. Never change this regular rate unless radical changes in methods or machinery are made by the management which reduce the amount of labor.

Task and Bonus Examples.

As illustrations of the operation of task and bonus in practice, I may refer to one case of hand labor for girl operatives without machinery, where the reduction in cost averaged about 50 per cent. during the first year after installation, while the girls accomplishing their tasks earned 40 per cent. more than previously. In another case of

two men operating a machine, the reduction in cost was about 35 per cent., notwithstanding a wage increase for tasks accomplished of 40 per cent.

In many classes of machine work, the increase in output is very large because of the standardization of the machine. In certain government work, for example, the increase in output was over 2½ times. In certain cases of which we have record, not merely was the labor cost substantially reduced, but the cost of material was reduced even as much as one-half, due chiefly to the thorough planning and routing of the materials for each piece of work.

The Speeding-Up Feature.

In considering such increase in output and reduction in cost as these, it must be borne in mind very distinctly that this saving is not accomplished by mere speeding up. In form making, for example, it is due in large measure to the use of unskilled in place of skilled labor for handling the materials; to the layout of each form by sketches carefully prepared and lettered; to the use of proper tools; and to the arrangement of benches so as to make it as easy as possible for the men to do their work. It is such savings as these that reduce costs of production in a fundamental way, that benefit the working man through increase of wages and reducing bother and friction. Such savings truly effect the economic production of wealth and must result in reducing costs to the consumer.



Toronto, Ont.—The Dominion Bridge Co., Montreal, have secured the contract for the supply and erection of the structural steel required for the new Technical High School.

Can. Elect. Assoc. Convention.—It has been finally decided to hold the annual Convention of the Canadian Electrical Association in Toronto, instead of in Fort William, as previously announced. The date of the Convention will be June 25, 26 and 27.

Pigeon, Pigeon & Davis, patent solicitors, 71a St. James Street, Montreal, report that 121 Canadian patents were issued for the week ending May 13th, 1913, of which 74 were granted to Americans, 25 to Canadians, 14 to residents of foreign countries, and 8 to residents of Great Britain and other colonies. Of the Canadians who received patents, 9 were residents of Quebec, 6 of Ontario, 6 of Manitoba, 2 of Alberta, 1 of New Brunswick and 1 of Nova Scotia. In the United States, for the same week, 712 patents were issued, 8 of which were granted to Canadian inventors.

MACHINE SHOP METHODS ^A_N^D DEVICES

Unique Ways of Doing Things in the Machine Shop. Readers' Opinions Concerning Shop Practice. Data for Machinists. Contributions paid for.

MILLING FIXTURE FOR JOINT COUPLINGS.

By H. R.

ILLUSTRATED is a very accurate method for milling and indexing. It was adopted for milling the flats marked (X), which had to be true with the center of the work. One side was done first, the piece being afterwards indexed round to do the other. Absolute accuracy with the center was secured, besides, the cutter was always in its correct position.

The fixture consists of a cast iron base plate (A), with a machined recess at (W) and carrying the taper bushing (B). Slots are also cut to set the fixture to the milling machine table, on which the operation is to be performed. The indexing plate (C) is of east iron, with a machined spigot corresponding to the recess (W). This plate carries the bushing (D), and as seen by the illustration, this bushing accommodates the locating plug (E), which is always intact with the taper bushings (B), on account of the spring (F) acting against the top of the bushing (D). A

ground spherical and with three points (K). The taper plug (L) is pressed into the plate (C), and kept from turning by the pin (M). The plug (L) also acts as a pivot for the base plate (A), and is held in position by the washer (N) which is screwed up to a shoulder on the plug (L) by the nut (O).

The piece to be machined is pressed on to the plug (L) and is located by the key (P), which slips into the keyway already cut in the work. The nut (H) with the spherical piece (J) is then adjusted up to the underside of the flange of the work. The split washer (Q) is next slipped in position and locked down tightly by the nut (R), the nut (V) being afterwards screwed up to the nut (H), locking everything, and forming a solid bed for the cutter to work upon without chattering. The two bolts (S) are screwed into the base (A) taking all strain off the taper plug (E). The spherical plate (J) eliminates all unevenness in the flange of the work. The cutter is set for accuracy by the hardened steel pieces (T), which are fixed to the plate (C).

made the jig illustrated herewith. It will be readily seen that accuracy with the hole (A) had to be observed in the bending operation.

A cast iron plate (B) has cast on it the projection (C), into which is driven a hardener steel plug (D). This corresponds with the hole (A). A steel block (E) has a half-round groove machined at (F) which corresponds to half the diameter of the steel bar to be bent and the block is shaped away at (G), so that the rod may be withdrawn after bending. It will be noticed that one side of the slot (G) is cut to a 3 degrees taper, this being to insure the bar springing to its desired shape after release from being bent. The block (E) is drilled at (H) for the fulcrum of the bending lever (N) and the jaw (J) has a groove to correspond with that already mentioned in the block (E). The screwed bolt (K) is passed through the jaw and the block, and can be drawn up tightly by hand lever (L).

To operate the jig, a bar is threaded through the lever end until it is far enough to allow the end (A) to be put

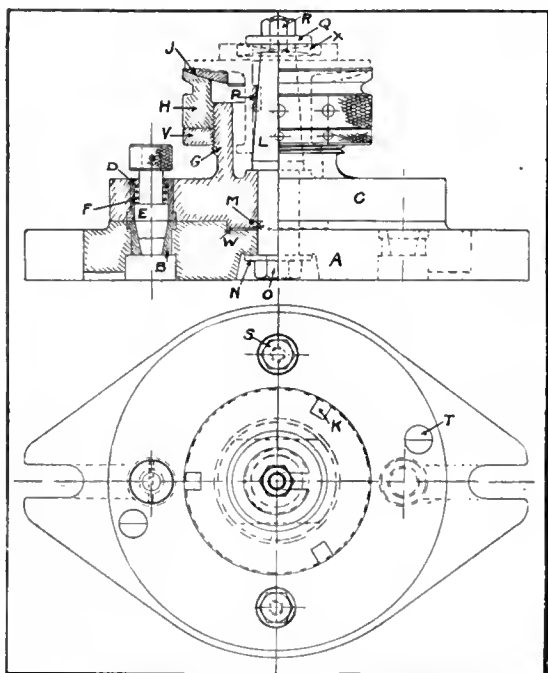

MILLING FIXTURE FOR JOINT COUPLINGS.

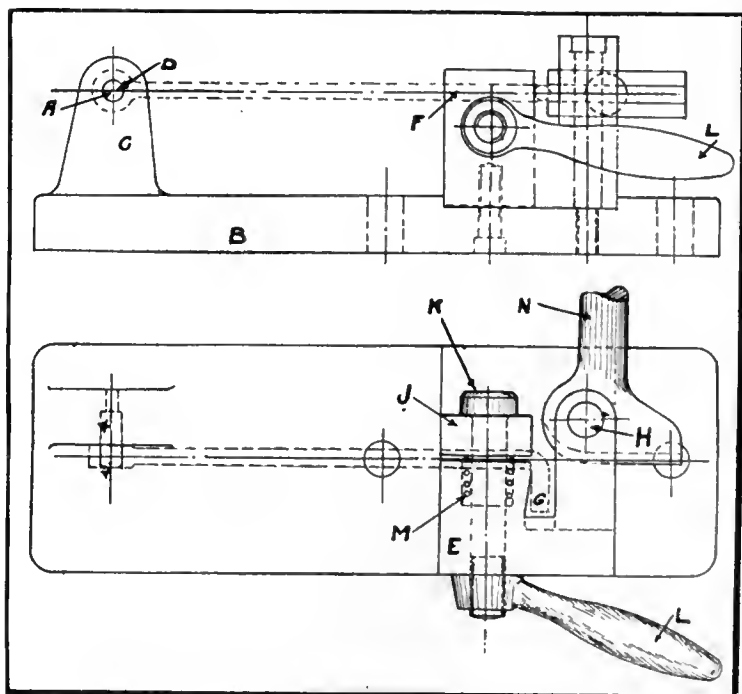

BENDING JIG.

screwed piece (G) is formed out of the plate (C), and carries the adjusting nut (H) and the lock nut (V). These nuts have a number of tommy bar holes in them for turning purposes. The top-most piece (J) is of hardened steel,

BENDING JIG.

By H. R.

HAVING a considerable quantity of $\frac{3}{8}$ inch steel bars to bend at a distance of $\frac{5}{8}$ inch from the end, we

on to the locating plug (D). The hand lever (L) is next turned until the bar is held securely between the jaw and block. The lever is then brought into action. It may be mentioned that this lever (N) has a groove cut so as to pre-

vent any possibility of the bar twisting out of its proper bending course. By putting pressure on to the lever (N) the bar may be bent to the desired shape without trouble, and if it be necessary for more leverage to be applied, this can be obtained by simply putting a piece of tubing of any length on to the lever (N). The spring (M) presses the jaw (J) back to its normal position when not in use, and the holes in the plate (B) are for holding same down to a bench.



KINGSTON LOCOMOTIVE WORKS.

AN address was given by Mr. A. W. Wheatley, general manager and vice-president of the Canadian Locomotive Works, to the "Knights of the Grip" at the Board of Trade rooms, Kingston, Ont., on Saturday night, May 24. Mr. Wheatley's address was based on the history of the Canadian Locomotive Co., past, present and future. He told how the first engine made in Kingston was turned out in December, 1856, and was handed over to the G. T. R., but shortly afterwards came to grief in the marsh near the outer station. The works at that time belonged to the Mortons, of distillery fame, but were afterwards bought by a Montreal syndicate, who turned out both engines and cars. A Kingston group of capitalists, headed by the late Sir Geo. Kirkpatrick, afterwards became proprietors.

For five or six years business flourished, the plant again changing hands by being purchased by Dubbs & Co., of Glasgow, Scotland. They were, however, very unfortunate, and the business in 1900 passed into the hands of liquidators. Mr. Hartly then purchased the works, and business has since continued to thrive. In 1911 a party of English capitalists took over the plant, and the present company was formed, the sum of \$500,000 being set aside for new machinery and the enlargement of the plant. Considerable money is still being spent.

Additions to Plant.

Up to 1911, \$150,000 had been expended in new and modern machinery, and approximately \$300,000 on new buildings. The buildings practically completed are the new tank and tender shop, new foundry, new pattern storage, new pattern and carpenter shop, and three crane runways. Electric cranes to facilitate the unloading and handling of materials have also been installed. The electric generating capacity has been doubled, likewise the air compressor and boiler capacity. The money set aside will be used exclusively for the additions, and will bring the plant up to a capacity of one engine per working day.

The shops yet to be built consist of a new erecting shop, having 10 pits equipped with two electric cranes, one of 150 tons capacity and the other of 100 tons. The present erecting shop will be torn down and a new machine shop built on its site. On the north side of Ontario Street a new machine shop will be built to take care of light machines and superheater work.

Pays \$500,000 in Wages.

"It gives one an idea of the growth of this institution," said Mr. Wheatley, "to learn that the pay roll in 1910 was \$306,000, whereas for this year it will exceed \$500,000. In the same period the force has been increased from 550 to 750. As to the future I am very optimistic. Being thoroughly familiar with the growth of the locomotive business in the United States, I feel that it would be ridiculous for me to make a guess as to the plant's ultimate capacity. Canada is a young country with a splendid future, and railroads are in their infancy.

"The locomotive business in Kingston is not, by any means, an experiment, and we feel that we have in our plant to-day the nucleus of an organization which may eventually turn out three, four and five locomotives per day. Such an organization naturally must have considerable effect on the growth of the city, and will undoubtedly be the means of bringing several other industries.

Kingston's Advantages.

"Kingston has many advantages which do not seem to be appreciated or understood. It has been spoken of as a poor labor market, which I contend is a mistake. With such beautiful surroundings, Kingston can be made an ideal labor market, providing we boost and put our shoulder to the wheel in building up the town. The great need to-day is working men's homes, and Kingston's future depends largely upon the solution of this problem. In the past conditions in this respect have been deplorable and hard to realize in a town which is beautifully situated, and with land which could be secured at such a reasonable price."



BRITISH AND AMERICAN WORKMEN.

THE report issued by the United States Congress Tariff Committee contains an interesting comparison of the efficiency of British and American workers and their wages. Despite the high wages paid in America to individual workmen, the report states that British manufacturers incur greater expense in wages because their workmen are less efficient, and, therefore, have

to be employed a great number of years to produce the same results.

According to the investigations made of 17 industries, Britain on an average uses one-sixth more power, and two and a half times more workmen than America to create a unit of \$100,000 increase in value of raw materials. To make this increase in value (the report states) in manufacture, where the United States needs only 73 workmen, \$400 in wages, and 222 h.p. machinery, Britain needs 165 workmen, \$500 in wages, and 367 h.p.

In the tinplate industry the corresponding figures are: United States, 88 workers, \$545, 134 h.p.; Britain, 205 workers, \$745, 105 h.p. The same conditions exist in the manufacture of cutlery and tools, with a slightly greater use of machinery in the States. It is stated that Britain uses more men comparatively, and consequently spends more wages in clock-making, the manufacture of motor cars, railway coaches, furniture, cotton goods, dyeing, linen, woollens, silks, hosiery, clothing, boots, gloves, and shipbuilding.

In shipbuilding the figures are: United States, 96 workmen, \$600, 209 h.p.; Britain, 198 workmen, \$680, 145 h.p. In cotton goods the figures are: United States, 47 workmen, \$515, 504 h.p.; Britain, 255 workers, \$597, 114 h.p. In the woollen industry the figures are: United States, 109 workmen and 223 h.p.; Britain, 283 workmen and 358 h.p., with the usual difference in wages. In the silk industry, the British use twice the machinery and three times more workmen than the United States to produce the unit of \$100,000 increase in value.

In paper goods, the States use twice the British horsepower, while Britain uses nearly four times the number of workmen. In the manufacture of motor cars, American manufacturers pay 96 workmen 20 per cent. more wages than are received by the 156 British workers creating the same unit of value, but the United States uses 30 per cent. more machinery.



ELECTRICAL EXHIBITION.

OWING to the numerous exhibitors who will leave Montreal to attend the Electrical Exhibition in New York, the dates for the First Annual Montreal Electrical Show have been changed. The exhibition was originally arranged to be held in the Arena from October 18th to 25th, but, now will be held in the same building from November 1st to 8th. Practically all the arrangements for the Electrical Show have now been completed, and the prospects are that it will be the most elaborate and most brilliant of its kind ever staged in Canada.

DEVELOPMENTS IN MACHINERY

A Record of New and Improved Machinery Tending Towards Higher Quality and Economical Production in the Machine Shop, Blacksmith Shop or Planing Mill.

HIGH SPEED DRILLING ATTACHMENTS.

THE Graham Manufacturing Co., Providence, R.I., have just brought out a new line of drill speeders or high speed drilling attachments. These are for use in drill presses of the larger class where small holes are to be made. The general advantage of the contrivances is that they convert a slow-running drill press into one of high speed, thus saving the cost as well as space required for an extra high speed machine. In radial drills a great many small holes for oil, dowels, set-screws, pins, etc., are made at much disadvantage, if some increasing device of this nature is not used.

The attachments are intended for use on all drilling machines from 20-inch to the largest radial. A little investigation will show that few of the upright type are speeded sufficiently fast for drills under $\frac{5}{8}$ inch, and radials naturally run more slowly still. The idea of trying to run machines of heavy design at the high speeds required is not good practice. The bearings being large, gears

Referring to the illustrations, Fig. 1 shows the type most commonly used. It is made in three sizes, accommodating drills from 0 to $\frac{3}{4}$ inch diameter. Fig. 2 shows one of the devices on an or-

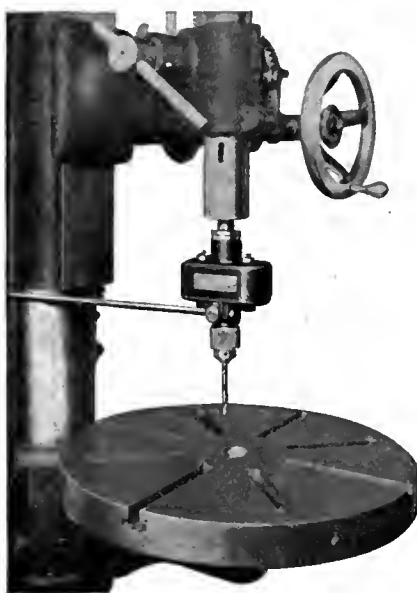

FIG. 2. THE SPEEDER IN A 21-INCH DRILL PRESS.

ordinary 21-inch drill press. Figure 3 shows the section and outline and Fig. 4 the complete moving parts. As to construction it will be seen that the shank is of the regular taper and on the bottom there is fastened a case-hardened gear. This gear meshes into two pinions mounted oppositely on case-hardened studs. To these pinions are fastened a pair of large gears which in turn mesh into the spindle pinion from opposite sides. The spindle and pinion are in one piece of tool steel hardened. At the bottom the spindle is fitted to a chuck, as shown in the foregoing cuts, or it may be extended downward and a hole put in to take taper shank drills, as shown in Fig. 5.

It will be seen from the duplex arrangement of the gears that side strains are greatly eliminated, and the driving mechanism almost ideal from the standpoint of the mechanical engineer. There is no end-thrust transmitted through the case. A ball-bearing is placed on a wide shoulder at the bottom of the shank. Below the ball-bearing is the top of the spindle, so that there is nothing intervening but the ball-bearing between the pressure applied to the shank from above and the pressure delivered to the spindle, chuck and drill

below. This arrangement is shown in the sectional view, Fig. 3. A further result in placing the ball-bearing in that location is that the ratio is only two to one, although the machine as a whole increases the speed three times.

The matter of having perfect alignment is of great importance and peculiar to these new machines. Trouble in this respect has been satisfactorily overcome by reducing the lower end of the shank and extending it downward until it is almost even with the top of the chuck itself. This extension or tail forms a long bearing inside the spindle. Further support is given the spindle by a bushing on the outside. This bushing is also made to take up any end wear that may make its appearance. The two studs, upon which the intermediate gear clusters are mounted, serve also to hold the case together. The case must not revolve, and a bar to keep it from doing so extends to the column of the machine or a rigid object of some kind, or it may be held in the hand. The machines described are simply speed increasers, and



FIG. 1. THE SPEEDER AS MOST COMMONLY USED.

would make too much noise, and much vibration would be set up in the vicinity of the machine. All styles of the attachments increase the speed three times.

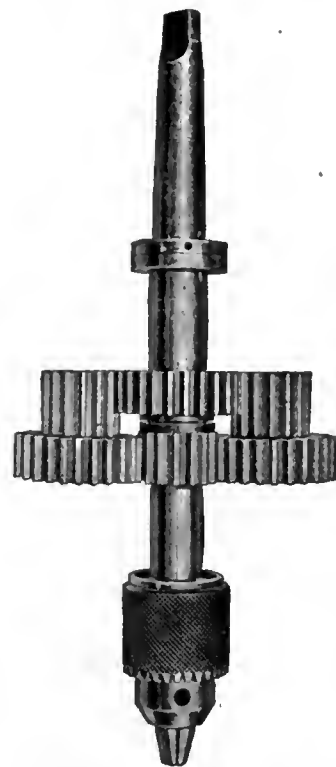

FIG. 4. ENTIRE MOVING PARTS OF SPEEDER. NOTE THE BALL-BEARING AT CENTRE.

must be fed by the feed mechanism of the main machine. They are made strong and rigid for hard service in regular manufacturing.

Figure 6 shows another type with a sensitive feed lever. This means that the main feed mechanism of the machine can be set at any desired point and locked, and that the actual feeding of the drill can be done by a mechanism within the speeder itself. This style is not intended for heavy, constant or manufacturing service. It should be kept in the tool-room for use on all classes of fine drilling, such as making holes to lines, making templates, jig holes, lay-outs, dies, dowel, oil, pin holes, etc. The feed mechanism of the main machine is not usually sufficiently sensitive to the touch, hence the necessity of a spring return lever on the speeder itself. In a general way the driving mechanism is the same as in the other machines. The speed is increased three times, and all gearing is arranged in duplex manner.

The spindle is driven by a bronze gear, broached to suit splines on its upper end. It extends upward into the shank for alignment as well as for necessary length to allow for the required end motion. In order to get vertical traverse, the spindle is mounted on a bronze racked sleeve. Into this rack there meshes a pinion, to which is fastened the return spring and the feed lever. This feature as well as an entire section and outline is shown in Fig. 7.

As an example of the application of the regular speeder, Fig. 8 shows boiler heads being drilled. The actual holes are 7-16-inch diameter and the metal 11-16-inch thick. In this case the time was cut in two or a little better.

JOHN H. HALL & SONS, LTD.

IN May 4, the firm of John H. Hall & Sons, Ltd., Brantford, Ont., entered upon the 11th year of its existence as a Canadian manufacturing en-

sons, E. W. and A. R. Hall started in the repair and jobbing business. These constituted the management, office staff and operations for a time, but business having increased and developed so quickly, it became necessary to constitute a partnership which included Mr. Hall and his four sons, and became known as John H. Hall & Sons.

A few more men were employed, after which the firm commenced to manufacture special machinery, and discontinued much of the small jobbing. This line was very successful, and embraced the manufacture of many new machines for special lines of work.

Up to this time, the firm had built a few pipe threading machines which were giving good satisfaction and business in this line began to grow. In view of the great possibilities of the Dominion, especially the rapid development of the West, the firm decided to specialize in this line. To this end every energy was directed towards the development and perfection of machines specially constructed to meet the requirements of the trade. As proof of this accomplishment, it is only necessary to mention that their machines are now in operation in all the tube mills, and many of the leading plumbing and steam-fitting plants in Canada. The Dalhousie Street premises becoming too small, the present factory was built three years ago, it being a substantial three-storey building with offices on corner of Centre and Bridge Streets.

In January, 1912, a charter was granted, authorizing the formation of the Company, now known as the John H. Hall & Sons, Limited, capitalized at



FIG. 5. SHOWING SPINDLE FOR TAPER SHANK DRILLS INSTEAD OF CHUCK.

terprise for machine tool products. One lathe and a drilling machine installed in an old building on Dalhousie Street, Brantford, constituted the equipment with which John H. Hall and his two

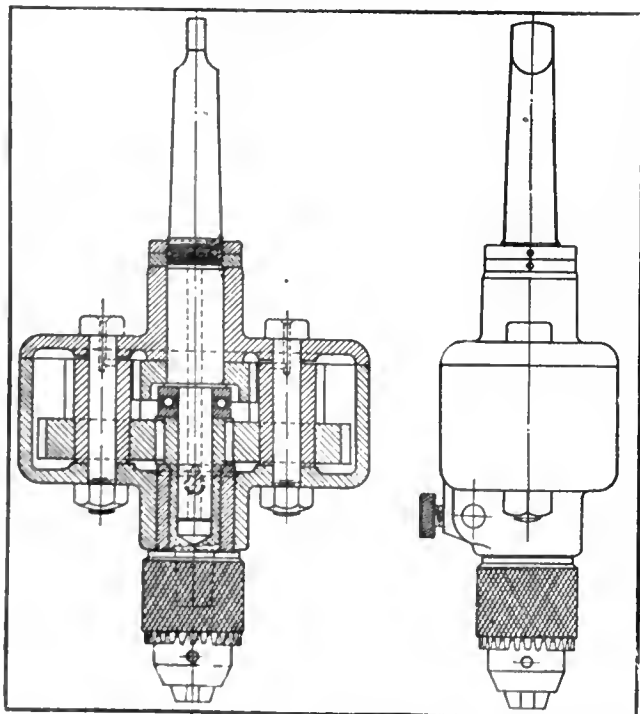

FIG. 3. SECTION OF STYLE MOST COMMONLY USED.

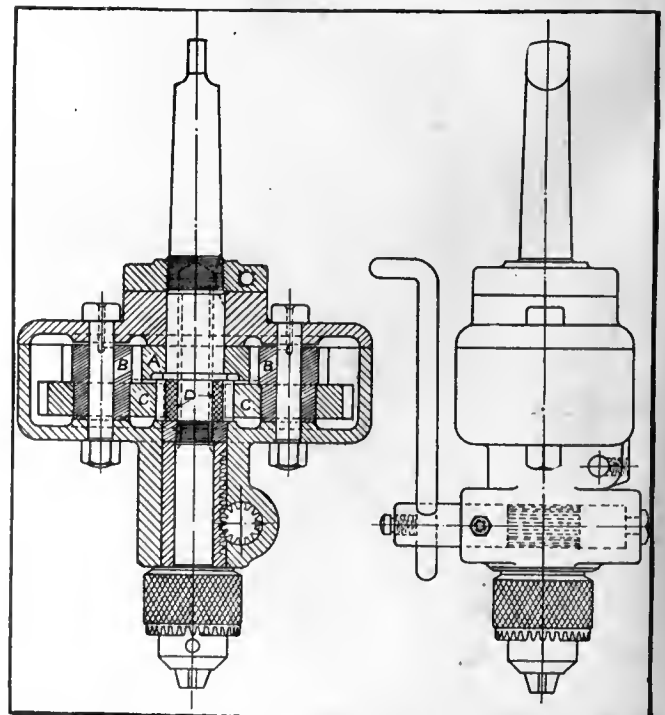

FIG. 7. SECTION OF STYLE WITH SENSITIVE FEED LEVER

\$100,000.00 with the following officers: President, John H. Hall; Vice-President, Leslie S. Hall; Secretary and Treasurer, Winton E. Hall; Director, Ernest L. Hall; Director, Reginald A. Hall.



CANADA NINTH IN WORLD SHIPPING.

IN the number of vessels and volume of tonnage, Canada's shipping last year showed a substantial increase. The total number on the register books was 8,380, measuring 836,278 tons; an increase of 292 vessels and 65,832 tons, compared with 1911. The number of steamers was 3,667, with a gross tonnage of 641,225. Assuming the average to be \$30 per ton, the value of the net registered tonnage of Canada at the end of 1912 was \$25,088,340. The number of new vessels built and registered during the year was 420, the tonnage 34,886, and the value \$1,569,870. During the year 241 vessels were removed from the register books. It is estimated that 42,490 men and boys were employed on ships registered in Canada during 1912.

Canada occupies now the ninth position in the shipping of all countries, Great Britain and her colonies being first with 12,580,488 tons, Germany second with 3,034,144, and the United States third with 2,617,791. In new shipping last year, Ontario led with 11,170 tons, British Columbia being second with 10,647, Nova Scotia third with 5,853, and Quebec fourth with 5,744. Wrecks numbered 19, strandings 10, and total losses 19.



CANADIAN PIG IRON OUTPUT IN 1912.

THE Bureau of Statistics of the American Iron and Steel Institute has received direct from the manufacturers the statistics of the production of pig

iron in Canada in the calendar year 1912. The total, including ferrosilicon, ferrotitanium and ferrophosphorus, was 912,878 gross tons, against 824,368 tons in 1911, an increase of 88,510 tons, or over 10.7 per cent. Of the total, 886,506 tons was made with coke, and 26,372 tons with charcoal, coke and electricity, etc., against 799,716 tons made with coke and 24,652 tons with charcoal, coke and electricity in 1911. The production of basic iron was 489,799 tons, against 413,303 tons in 1911; of Bessemer pig iron, 228,742 tons, against 186,274 tons in 1911; of foundry pig iron and ferrosilicon, 194,208 tons, against 190,324 tons in 1911; of malleable Bessemer and white and mottled pig iron, direct castings, ferrotitanium, ferrophosphorus, etc., 129 tons, against 34,467 tons in 1911.

On December 31, 1912, Canada had 19 completed blast furnaces, of which 14 were in blast and 5 were idle. Of the total, 15 usually use coke for fuel, and 4 use charcoal. One charcoal and two

did not show an increase over the output of the preceding year. It was not until 1902 that Canada began to develop its steel industry.



NEW R. & O. DOCKS AT TORONTO.

THE Inland Line, under the R. & O. merger, are bringing to Toronto five additional steel freighters from Lake



FIG. 8. EXAMPLE OF DRILLING 7-16 IN. HOLES IN BOILER HEADS 11-16 IN. THICK.

coke furnaces were being built on December 31. In 1912, three plants made ferroalloys in electric furnaces.

The production of all kinds of pig iron in Canada in the last nineteen years is given below. Spiegeleisen, ferromanganese, ferrosilicon, ferrotitanium, ferrophosphorus, etc., are included:

	Tons	Tons	
1894.....	44,791	1904.....	270,942
1895.....	37,829	1905.....	468,003
1896.....	60,030	1906.....	541,957
1897.....	53,796	1907.....	581,146
1898.....	68,755	1908.....	563,672
1899.....	94,077	1909.....	677,090
1900.....	86,090	1910.....	740,210
1901.....	244,976	1911.....	824,368
1902.....	319,557	1912.....	912,878
1903.....	265,418		

In the ten years from 1903 to 1912 there was but one year, 1908, when the production of pig iron in the Dominion

Superior, and, with the inland fleet already in their possession, will have a fleet of fifteen vessels in service between Toronto and the upper lakes. This means that with the two new freighters recently built for the Merchants' Mutual Line, Toronto will have seven additional steel freighters this season. A start on new docking facilities, which are to cost nearly a million dollars, will be made this summer. As soon as word of a decision regarding the viaduct is received, a commencement will be made on the new docks. The new structure is to be of concrete, and with the territory between Yonge and Scott streets will extend five hundred feet south of the present docks. The work on the southern portion will be the first to be undertaken, and in this way, the docking of steamers at the present wharves will not be interfered with.



FIG. 6. SHOWING STYLE HAVING SENSITIVE FEED LEVER.

The MacLean Publishing Company

LIMITED

(ESTABLISHED 1888.)

JOHN BAYNE MACLEAN - - - - - President
H. T. HUNTER - - - - - General Manager

PUBLISHERS OF

CANADIAN MACHINERY AND MANUFACTURING NEWS

A weekly newspaper devoted to machinery and manufacturing interests, mechanical and electrical trades, the foundry, technical progress, construction and improvement.

H. V. TYRRELL - - - - - Business Manager
PETER BAIN, M.E. - - - - - Editor.

OFFICES:

CANADA
Montreal, Rooms 701-702 East-
ern Townships Bank Bldg.
Toronto, 143-149 University
Ave., Phone Main 7324
Winnipeg, 34 Royal Bank
Bldg., Phone Garry 2313
Vancouver, H. Hodgson, 2640
Third Ave. West.

GREAT BRITAIN
London, 88 Fleet Street, E.C.
Phone Central 12960
E. J. Dodd

UNITED STATES
New York, R. B. Huestis, 115
Broadway, New York, N.
Y., Phone 2209 Rector
Chicago, A. H. Byrne
Room 607, Marquette Bldg.
140 S. Dearborn St., Chicago

CABLE ADDRESS:

Macpubco, Toronto. Atabek, London, Eng.

SUBSCRIPTION RATE:

Canada, \$2.00; United States, \$2.50; Great Britain, Australia and other colonies, 8s. 6d. per year; other countries, \$3.00. Advertising rates on request.

Subscribers who are not receiving their paper regularly will confer a favor on us by letting us know. We should be notified at once of any change in address, giving both old and new.

Vol. IX.

JUNE 5, 1913

No. 20

PRINCIPAL CONTENTS.

Electrically-Driven, Two High Reversing Rolling Mill.....	583-586
New N. T. R. Shops at St. Malo, Que.	586
Recent Judicial Decisions	586
New Grain Elevator	586
The Joint Feature in Foundry Pattern Construction.....	587-589
General	589
Pulp Industry in Canada...Incorporation is Becom- ing General...Large Order for Steel Pipe Pending... Visiting Great Lakes Ports.	
High Speed Gear Hobbling Performance and Equipment..	590-593
Time Study a Basic Principle of Scientific Management...	591-596
Machine Shop Methods and Devices	597-598
Milling Fixture for Joint Couplings...Bending Jig.	
General	598
Kingston Locomotive Works...British and American Workmen...Electrical Exhibition.	
Developments in Machinery	599-600
High Speed Drilling Attachments...John H. Hall & Sons, Ltd...Canadian Pig Iron Output in 1912.	
Editorial	602
Industrial and Construction News	603-607
Engineering Electrical Waterworks...Wood- working...Municipal Building Notes General Industrial Railways Bridges Contracts Awarded...Tenders...Trade Gossip Personal... Obituary...New Incorporations Miscellaneous.... Catalogues.	
General	607
British Railway Accidents...To Encourage Shipbuild- ing in Canada.	
Selected Market Quotations	608-609
The General Market Conditions and Tendencies	609

THE CANADIAN SHIPBUILDING INDUSTRY.

IN another section of this issue of Canadian Machinery will be found particulars relative to the part which this Dominion is going to play in the building of its Government vessels in the coming days, and it is not overstraining the situation, when we say that the public conscience

is becoming awakened, and that a strong undercurrent of public opinion is favorable to the propagation of the already established shipbuilding industry.

It is abundantly evident that Canada's merchant and naval marine, if we may use the latter term, is growing and developing in size and number of vessels, at a rate undreamt of a few years ago, and we can take a pardonable pride in the achievement of our premier shipyard at Collingwood, Ont., as exemplified in the successful launch of the big lake freighter, "James Carruthers," even although the vessel's size and appointments do not approach to the masterpieces of naval architecture and marine engineering produced in Great Britain and Germany.

A growing disposition is becoming apparent, particularly with reference to vessels required for Government purposes, to have these either built by already established shipyards within our borders, or make it necessary for British builders who contract for them, to establish plants for the purpose at a number of our leading ports. There has been much loose talk regarding the coming of leading British shipbuilders to our shores, but, so far, little has materialized in this direction, and it does not seem likely that much progress will be noted until steps are taken to insist on our ships being built on Canadian soil, and by resident Canadian artisans.

The shipbuilding and marine engineering industry needs fostering by our Federal Government, and a little more intimacy with what is now being accomplished by the existing concerns, on the part of the responsible Departments at Ottawa, is all that is necessary to secure increased support to what should be one of our important national industries.

Industrial enterprises are, as is well known, more or less interdependent, aiding and abetting each other, as it were, and no more powerful adjunct to the machine tool and mechanical engineering industries, already in our midst, is comparable to that of shipbuilding and marine engineering. In the production of vessels and their machinery, there is requirement of the best and most up-to-date shop equipment, and the opportunity is given for a display of a high degree mechanical engineering skill. As in every other manufacturing concern, it is necessary that equipment keep abreast of the times, a circumstance of the highest import to all whose product forms a necessary part of shipyard equipment.

We do not appreciate, as fully as we might, the all-round benefits to be derived from using our influence in the direction of fostering the Canadian shipbuilding industry, the railroad feature being so deeprooted, as to almost exclude every other consideration. The two are not antagonistic, and will never be; but, as a matter of fact, will really contribute to the higher achievement of product in each other.

ELECTRIC DRIVING OF ROLLING MILLS.

A NUMBER of reasons for British backwardness are given in the paper describing a new form of electrically-driven two-high continuous running reversing mill, which we reproduce in this number. The day has not yet arrived, however, according to Mr. Lamberton, when it can be claimed that, by the universal adoption of electricity as the motive power for driving rolling mills in iron and steel works, the highest economy in running costs can be attained; and every proposed installation of such machinery should be most carefully considered in relation to the existing conditions and decided upon its true merits.

INDUSTRIAL ^A_N^D CONSTRUCTION NEWS

Establishment or Enlargement of Factories, Mills, Power Plants, Etc.; Construction of Railways, Bridges, Etc.; Municipal Undertakings; Mining News.

Engineering

Lethbridge, Alta.—Niven Bros. will erect a foundry. It will have a department for brass work.

Tillsonburg, Ont.—Work was started last week on the new factory of the Tillsonburg Electric Car Co., Tillsonburg, Ont.

Hamilton, Ont.—The Canada Steel Co. have taken out a permit for the erection of a \$10,000 addition to their plant on Sherman Avenue.

Calgary, Alta.—The C. N. R. is considering the erection of a new shop here to employ about 2,000 people. Nothing definite is known regarding it.

Montreal, Que.—Canadian Drednot Motor Trucks, Ltd., plans to erect a new and larger factory, and will make a new issue of preferred stock for that purpose.

Vancouver, B.C.—The Tyee Copper Co., Ltd., has concluded a contract with the Ptarmigan Mines, Vancouver Island, to treat its ore at the Ladysmith smelter.

Halifax, N.S.—Damage to the extent of \$10,000 was done on May 31st at the Nova Scotia Car Co.'s plant by an explosion of molten iron in the cupola. One man was killed.

Hamilton, Ont.—It is reported that the International Harvester Co. have plans ready, and are about to let contracts for the construction of a five-storey addition, 100 x 200 ft.

Hamilton, Ont.—George E. Jobborn will erect a factory at 56 Guise Street for the manufacture of solder, white brass and white metal alloys. "Hamilton" will be the trade mark.

Moose Jaw, Sask.—The Phoenix Mfg. Co., Eau Claire, Wis., will erect a tractor manufacturing plant in Moose Jaw, Sask. The company will incorporate as the Canadian Phoenix Tractor Co., Ltd.

Windsor, Ont.—The usual exemptions have been granted to the Swedish Crucible Steel Co., the Kelsey Wheel Co., the Detroit Steel Product Co., and the Vincent Steel Process Co., who will erect their plants here.

Hamilton, Ont.—A new machine shop was recently opened at 281 Emerald Street N. W. Tew & Co. are the proprietors. Small press tools and metal patterns are their specialty, although they are doing a general manufacturing business as well.

Saskatoon, Sask.—The Western Foundry and Machine Co., Ltd., who were burned out some time ago, have rebuilt a foundry with 3,500 square feet floor space, a machine shop of 3,500 square feet, and a pattern shop of 753 square feet. The most up-to-date equipment is being installed.

Parry Sound, Ont.—The tug D. S. Pratt with the big dredge Sydenham has arrived from Midland to dredge the bottom of the harbor, and make ready for the placing of the cribs for the three hundred foot docks at the Canada Chemical Co.'s smelter. The smelter is well under way, and when completed will manufacture charcoal iron in large quantities.

Owen Sound, Ont.—The Town Council last week considered a proposal of Mr. F. P. Samwell, promoter of the rolling mills, who now wishes to remodel an abandoned factory, instead of building a new one. The proposition was not favored by the Council. Some time ago the ratepayers voted him \$150,000 on condition that he build rolling mills within the town.

Hamilton, Ont.—The Dominion Steel Castings Co., Ltd., are increasing their plant and equipment. A finishing department, 65 x 130 ft., is now under construction, and as soon as completed a moulding room, 110 x 120 ft., will be commenced. The additional equipment will include one acid open hearth furnace, six moulding machines, two jarring machines of 16,000 lbs. capacity, two electric travelling cranes of 25 tons capacity, and an auxiliary hoist of five tons capacity. Two drying ovens, 16 ft. by 30 ft., are being built, and will be equipped with mechanical exhaust to facilitate the drying of moulds. Two core ovens will also be added, increasing the capacity of the plant from 1,200 to 1,500 tons per month. The additions will cost \$90,000. Prack & Perrine are the architects, the Hamilton Bridge Co. are supplying the structural steel, and H. C. Christman & Co. are the contractors.

Electrical

London, Ont.—The sum of \$442,573 has been appropriated for the electrification of the London and Port Stanley Railway.

Westmount, Que.—The Montreal Water and Power Co. will increase their electric light plants and raise their water tank 25 feet.

Hagersville, Ont.—The installation of a hydro-electric transformer station at Hagersville is contemplated by the Ontario Hydro-Electric Commission, Toronto. Three 600 horse-power transformers will be required.

Newmarket, Ont.—The ratepayers have voted in favor of the Hydro-Electric System against the proposition of the York Radial, to supply power at \$25.50 h.p. if the town spend \$12,000 on the distributing plant.

Windsor, Ont.—The Essex Light and Power Co., understood to be identified with the Detroit Edison Co., are laying power cables across the Detroit River to Sandwich, to distribute power to Essex, Leamington, Kingsville, Harrow and Amherstburg.

Windsor Mills, Que.—The Canada Paper Co., Windsor Mills, Que., have purchased what are known as Kingsey Falls, on St. Francois River, near Windsor Mills, Que., and will erect a dam and power house this summer, and supply electric power for their plant at Windsor Mills.

Toronto, Ont.—The Hydro-Electric and Power Commission have issued instructions to go ahead with the Chatham-Windsor section of the high tension line from St. Thomas to Windsor. The commission will erect transformer stations at Niagara Falls, Dundas, Toronto, Berlin, Stratford, owing to the increased demand for power. Engineers were instructed to prepare estimates for the cost of constructing, equipping and operating an electric railway through Markham, Stouffville, Unionville, Fort Perry, Uxbridge, etc. The St. Thomas to Chatham route has not been decided on.

Water Works

Paris, Ont.—The town council contemplate the purchase of waterworks supplies.

St. John, N.B.—The commissioners will extend the Marble Cove sewer along the shore to the river, at a cost of \$10,000.

Winnipeg, Man.—The Anglo-American Filter Co. will erect a filter plant at a cost of between \$15,000 and \$20,000.

New Westminster, B.C.—The council have approved of steel pipes at a cost of \$8,800 for supplying water to Milliardville.

Esquimalt, B.C.—Esquimalt is contemplating solving its sewage problem at an estimated cost of \$500,000. Plans are being prepared.

Merriton, Ont.—Plans for a \$35,000 sewerage system have been approved by the Board of Health. Seven miles of sewer are to be laid.

St. John, N.B.—A contract for the waterworks supplies at a cost of \$8,700 has been given by the city council to John Birch Co., London, Eng.

Lindsay, Ont.—Supt. Hammond has been instructed by the Water Commissioners to proceed with the construction of a new filter, costing \$2,500.

Timmins, Ont.—The town will bring its water from a source some distance out of town. The engineers are Sutcliffe & Neelands, New Liskeard, Ont.

Port Coquitlam, B.C.—Engineer Verner has submitted estimates to the council for water mains for Mairllardville. The steel mains will cost \$8,800, and the cast iron \$11,700.

South Vancouver, B.C.—A 1,000,000 gallon pump will be purchased by the Water and Light Committee who will also construct a 100,000-gallon tank and a 750,000-gallon steel standpipe.

Hamilton.—The city council has passed a by-law for \$150,000 for waterworks improvements, to include \$50,000 for new services; \$1,000 for hydrants and \$10,000 for meters and installations.

Golden, B.C.—The Canadian Pipe Co. have been advising the Board of Trade concerning the installation of a water system. It was stated that a modern system could be installed for \$45,000.

Montreal, Que.—The council have decided to construct twin boulevards along the banks of the city aqueduct from Point St. Charles to Laehine. The lowest tender received for widening the aqueduct is \$2,000,000.

Montreal, Que.—In view of the fact that Norman M. McCloud, contractor in charge of the construction on the new filtration plant, has protested to the Board of Control that the sub-soil is defective, the Board have appointed three engineers to report on the nature of the ground selected as a site for the filters.

Municipal

St. Catharines, Ont.—A by-law to raise \$5,000 to extend the civic-owned gas mains has been passed.

Guelph, Ont.—It seems that the Wellington County Council will not expend \$400,000 on county roads as reported.

Burnaby, B.C.—Municipal engineer Macpherson is in favor of the expenditure of \$2,500,000 on the construction of 100 miles of macadamized roads in Burnaby.

Saskatoon, Sask.—Heenan & Froude have been asked for an amended tender for the incinerator, providing for the heat from the burning refuse to pass through a boiler in the pump house.

Building Notes

Toronto, Ont.—The new Dominion Bank Building, about to be erected will cost \$1,000,000. It will be 185 ft. high, with 168 frontage on Yonge St., and 75 ft. on King and Melinda Streets.

Ottawa, Ont.—The following amounts have been voted for Public Works in Toronto by the Government: For customs examining warehouse, \$500,000; military buildings, \$250,000; postal station A., \$250,000, etc.

Wood-Working

Fort Rouge, Ont.—Fire recently destroyed the sash and door factory of G. A. Broadbent, with a loss of \$50,000.

Red Deer, Alta.—The Great West Lumber Co. have installed new equipment to increase their output to 100,000 ft. a day. The three boilers were made by Goldie & McCulloch, Galt, Ont.

Medicine Hat, Alta.—William Ruthford and J. Merriam, Medicine Hat, Alberta, are preparing to start a wood-working industry. They propose spending about \$15,000 on machinery.

Preston, Ont.—The Preston Chair Co., Ltd., before locating their plant in this town, have asked for a free site, and a loan of \$15,000. They will build a

three-storey brick building, 40 by 150 ft., with a boiler house and dry kiln in addition, and will give employment to at least thirty hands.

Red Deer, Alta.—Baird & McKenzie have erected a sash and door factory in North Red Deer, two storeys high, 100 x 40 ft., near the Great West Lumber Co.'s saw mill. The woodworking machinery has been supplied by the Berlin Machine Co., of Hamilton, each machine being fitted with exhaust pipes to carry away the sawdust, etc.

Calgary, Alta.—The Hudson's Bay Co. have recently purchased through Messrs. Loughheed & Taylor, Ltd., the factory and plant of the Calgary Woodworkers, Ltd., in East Calgary, for \$42,000. There, they will manufacture their fittings and fixtures required for several new stores being erected by the Hudson's Bay Co. It is proposed to extend the plant, and to instal new machinery.

General Industrial

Hamilton, Ont.—The Canadian Cottons, Ltd., will erect a \$28,000 extension to their factory.

Calgary, Alta.—The Crystal Ice Co. will shortly erect an ice plant and build a skating rink.

Sutton, Que.—L. L. McClarty, marble dealer, will purchase an electric hammer outfit for his yards.

Ingersoll, Ont.—The ratepayers have voted in favor of loaning \$20,000 to the Standish Mfg. Co., of Toronto, makers of washing compounds.

Sherbrooke, Que.—The Sherbrooke Knitting Mills sustained several thousand dollars damage to machinery when a fire broke out on Saturday, May 24th.

Peterboro', Ont.—The Brinton Carpet Co. have decided to instal more machinery in their plant here. G. R. Toppling, of Toronto, has been re-elected president.

Ridgeway, Ont.—A representative of the Monarch Belt Co. was in town last week looking for a site on which to erect a ten-storey factory for the manufacture of belts.

Quebec, Que.—The shoe factory formerly occupied by the James Muir Co., and recently operated by Ludger Dechene, was damaged by fire May 22, to the extent of \$17,000.

Port Coquitlam, B.C.—Two car loads of machinery for the Call Switch Co. new plant at Pitt River were delivered last week. Six more cars will follow. Ira A. Call is president.

Vegreville, Alta.—The Vegreville Brick Co., with A. V. Mitchell as manager, has bought the property of C. Gordon, and will have a plant capable of turning out 15,000 bricks a day.

Welland, Ont.—Machinery was placed in the Empire Cotton Mills on Tuesday, May 20th, six months after the first sod was turned. The plant is worth \$250,000 and the contractors were Hitch & Co.

Red Deer, Alta.—Improvements to the plant of the Cement Builders, Ltd., will increase their output to 90,000 bricks a day. A 100 h.p. boiler has been added, also a 320 h.p. Waterous engine.

Melita, Man.—The voters have endorsed the by-law to grant a 30-year franchise to R. E. Denny, of Brandon, Man., to supply the town with natural gas, artificial gas, a heating system, electricity and waterworks.

Sydney, N.S.—The Nova Scotia Steel and Coal Co. has disposed of its entire coal output for this year. Work is well advanced in sinking the No. 6 colliery at Sydney Mines, and the old Jubilee pit is being extended.

Montreal, Que.—The Canada Glass Corporation, Ltd., has, it is stated, been formed with an authorized capital stock of \$8,000,000. It will take over the Diamond Glass Co., the Sydenham Glass Co. and the Canadian Glass Co.

Montreal, Que.—The Swift Canadian Co. has just completed a meat packing and meat handling plant at the corner of St. Timothy and Craig Sts. The plant is equipped with ammonia refrigeration machinery, with insulated walls and 4-inch nonpareil cork.

Scarboro', Ont.—A. H. Wagstaff, brick manufacturer, has bought lot 29 in concession D. in the township of Scarboro' for \$50,000, on which he will erect a new brick plant. The farm is known as Alexander Sterling Farm, and is two miles from Scarboro' Junction.

Hamilton, Ont.—The Hamilton Gaslight Co. has been purchased by a new company in which the officers and directors are: President, John G. Gauld, K.C.; Vice-President, C. W. Knisely, Chicago; Directors: J. W. Nesbit, K.C., C. V. Langs, L. H. Gray, Thomas Crosthwaite, N. Moore; Secretary, John Kellor.

Railways—Bridges

Vancouver, B.C.—The C.P.R. will construct a subway under the Great Northern tracks at White Rock, and will have plans ready in a week or two.

Fredericton, N.B.—The first steel out of Fredericton on the St. John Valley Railway is being laid, and rapid progress is being made by the track laying crew.

Montreal, Que.—The C.P.R. intends to place in commission ninety-four additional standard sleepers, twenty-five diners, ten buffet observation and twelve observation and fifty-six tourist cars.

Victoria, B.C.—The wooden bridges on the Esquimault and Nanaimo railway on Vancouver Island between Victoria and Wellington will be replaced by 12 steel structures of the most modern type.

Toronto, Ont.—The C.P.R. is building a second track from Islington to Guelph Junction, about thirty miles. Tenders will be called for excavation, masonry and concrete necessary for making the bridge across the Humber River, near the Lambton Golf Links, sufficient to carry a second track.

Toronto, Ont.—The C.N.R. will build a tunnel 2,360 ft. long, covering the proposed route from Dovercourt Road through the city and the township of York to the Humber River. The line will cross the Humber river on a high level bridge. The tunnel will cost between \$300,000 and \$500,000.

Contracts Awarded

Welland, Ont.—The Canada Forge Co. have awarded the contract for build-a large extension to the Standard Steel Construction Co.

Saskatoon, Sask.—The Saskatoon-Sutherland Construction Co. have given the contract for laying a street railway to Lonergan & Hansford, Saskatoon.

Guelph, Ont.—Galbraith & Craig, of Montreal, have been awarded the contract to build a concrete bridge across the Speed River for \$10,000, by the Sewerage and Public Works Commission.

Kincardine, Ont.—The Waterworks and Electric Light Commission have placed an order with the John Inglis Co., Toronto, for a steam pump, costing \$17,035, to be delivered within six weeks.

Toronto, Ont.—The Harbor Commissioners have decided to award the contract for dredging the water front to the Canadian Stewart Co., Montreal. 31,270,000 cubic yards will be dredged, and \$6,462,344 will be spent on dredging.

Moncton, N.B.—The Provincial Department of Public Works have award-

ed contracts for bridges as follows: the MacGuire bridge in Charlotte county to A. E. and G. F. Smye, Alma, at \$3,400; Anderson-Hollow culvert, at \$6,300.

Wasdell's Falls, Ont.—Tenders will be received up till June, 16, for the construction and equipment of a hydro-electric power plant. Plans and specifications may be obtained from the Hydro-Electric Power Commission, Toronto. W. W. Pope, secretary.

Montreal, Que.—The Department of Railways and Canals have awarded the contract to the Marconi Co., of Canada for the erection of two stations on the Hudson Bay Railway terminals, viz., at Port Nelson and Le Pas. The necessary power will be obtained from 20 h.p. Canadian-Fairbanks engines, and each station will have a range of 500 miles.

Montreal, Que.—The C.P.R. have awarded a contract to John S. Metcalf Co., Ltd., Montreal and Chicago, for the construction of buildings along the new line of the C. L. O. & W. Railway, about 180 miles in length, extending from Glen Tay, Ont., to the main line at Agincourt, not far from Toronto. The contract includes seven brick stations, twelve wooden stations, nine 40,000-gallon water tanks, a twelve-stall engine house with turntable, machine shop, coaling plant, ash pit and sand house; nine freight sheds, an ice house, seven station residences, twenty-five tool houses, and miscellaneous buildings, a total of about eighty-five structures.

Tenders

Winnipeg, Man.—Tenders will be received by the Board of Control up to June 20th for the supply and installation of machinery, etc., for a refrigeration plant at the municipal hospitals. M. Peterson, see.

Winnipeg, Man.—Tenders will be received by G. R. Coldwell, acting minister of Public Works, up to July 2nd for the construction and completion of the new parliament buildings, Winnipeg, buildings to be completed May 1st, 1917. Provincial architect 261 Fort St.

Marine

Ottawa, Ont.—Tenders were called on Tuesday, June 3, for the first section of the \$50,000,000 Welland Canal. The route will follow the valley of the Ten Mile Creek from Lake Ontario, crossing the present canal below lock No. 11.

Ottawa, Ont.—The House has voted \$4,000,000 for canal estimates, including \$2,000,000 for a new Welland Canal.

The lock will be 800 ft. long by 80 ft. wide. Contracts will be called shortly for the first section, beginning at Lake Ontario end.

Toronto, Ont.—The steel hydraulic dredge, "Port Nelson," was launched at the Polson Iron Works on Saturday May 31st. It was built by the Department of Railways and Canals for deepening the Hudson Bay Railway terminal at Port Nelson.

Port Arthur, Ont.—On June 2, the "Noronic," the Northern Navigation Co. flag ship, was launched at the plant of the Western Dry Dock and Shipbuilding Co. Following are dimensions: Length all over, 385 ft.; length between perpendiculars, 362 ft.; breadth, 52 ft., and depth, 28 ft. 9 inches.

Toronto, Ont.—The Toronto Harbor Commission will probably do the dredging work in connection with the water front development at an estimated cost of \$6,462,334. The necessary sewers, dredges, etc., will be built in Canada, the cost of this equipment amounting to about \$500,000. Tenders were received from Sir John Jackson, London, England, from the United States, and from Canadian contractors.

Obituary

William Strongman, for many years with the firm of A. M. Robertson, shipbuilders, and later with the G.T.R. as bridge builder, met with an accident while doing repair work on his roof at 150 Dundas St., Hamilton, and died May 29th. He was born in Cornwall, Eng., and had been a resident of Hamilton for forty-three years.

Malcolm Ross, chief engineer at the municipal waterworks pumping station, Fredericton, N.B., died on Saturday afternoon, May 10, after a long illness. He was born in Mangerville and was in his 78th year. He entered the employ of the city as engineer in the water department when the waterworks was installed, about thirty years ago.

John Breckenridge, a well known railway and irrigation contractor, of Calgary, Alta., died in a hospital there on Wednesday, May 28th, from pneumonia. He had charge of the C.P.R. irrigation system in Alberta, which took five years to complete; also of the C.N.R. construction from Edmonton west through the Yellow Head Pass, to Port Mann. He was born in Scotland in 1861, and had much experience in Montana, U.S.A. and other States. He was president of

the Calgary Pressed Brick Co. and a director of the Calgary Sewer Pipe Co.

Personal

John O'Neill, city engineer of Fredericton, N.B., recently tendered his resignation to the City Council.

James W. Ewing has been appointed superintendent of the Call Switch Co.'s new plant at Pitt River, near Port Coultlam, B.C.

H. H. Couzens, the new manager of the Toronto Hydro-Electric System, will receive \$12,000 per annum, under his three-year contract.

Bernard Green, who has for some years been chief of the office staff of the Nova Scotia Steel Co. at Wabana, has been promoted to the head office of the company in New Glasgow, N.S.

W. S. Sampson, for many years manager of the Gananoque Spring and Axle Co., has been appointed managing director of the Steel Products of Canada, Ltd., an amalgamation of several Ontario spring and axle companies.

A. D. Swan, assistant engineer to the Montreal Harbor Commission, has resigned. He will visit Chili, and report on various projects, including three harbors, for a large British syndicate. On the completion of his work, and after a visit to England, Mr. Swan will return to Montreal.

James Robertson, an old employee of the Jenckes Machine Co., Sherbrooke, Que., has severed his connection with that firm, and accepted a position with the Canadian Rand Co. On the occasion of his leaving, Mr. Robertson was presented with a handsome Masonic ring and pins, accompanied by an address read by Mr. Lewis Dunsmore.

G. L. Guillet has been appointed associate professor of mechanical engineering at McGill University, and A. J. Kelley lecturer on surveying. The resignation is announced of Professor V. I. Smart, of the Department of Railway Engineering, on his appointment as general manager of the General Railway Signal Co., of Canada.

T. P. Howard, managing director of the Phonenix Bridge and Iron Works Co., Ltd., has been elected vice-chairman of the Montreal branch of the Canadian Manufacturers' Association, and W. F. Angus, Canadian Steel Foundries, Ltd.; F. H. Hopkins, Dominion Wire Rope Co., Ltd., and R. H. McMaster, Steel Co. of Canada, Ltd., members of the executive committee.

New Incorporations

Arthur Atherton, president of the French Co., is now in Canada, and with Mr. Meldrum, will shortly leave on a trip through the Western Provinces.

Quebec, Que.—The Rimouski Brick and Terra Cotta Co. has been incorporated, with \$100,000 capital. William Price and Wm. M. Dobell are among the incorporators.

Winnipeg, Man.—The McCoy Process Refrigeration Co., Ltd., has been incorporated in Manitoba with a capital of \$1,000,000 for the purpose of acquiring from Charles W. McCoy a certain patent relating to a refrigerating process, described as the "McCoy" Cooler.

The Herbert Morris Crane and Hoist Co., Ltd., has just been incorporated, and will handle the Canadian business of the well known British firm, Herbert Morris, Ltd. A complete line of lifting machinery will be sold and a manufacturing plant, it is understood, will be built shortly, in order to facilitate delivery. Herbert Morris, president of the English company, will be president of the Canadian company.

Miscellaneous

The P. Lyall Construction Co. statement, which will be out soon, will show contracts on hand of \$4,000,000, one million more than a year ago.

The Provincial Steel Co., of Cobourg, for which a winding up order has been issued, will shortly resume business. It is reported that a strong company is behind it.

The Pas, Man.—Tenders addressed to H. H. Elliott, M.D., secy.-treas. of the Town of The Pas, will be received up to 6 p.m., July 1st, 1913, for the supply and delivery of the following materials, and the performance of certain works: Tender B.—Trenching and laying of approximately—4,400 ft. of 12 in. steel pipe; 3,500 ft. of 10 in. steel pipe; 4,400 ft. of 8 in. steel pipe; 2,000 ft. of 6 in. steel pipe; setting valves, hydrants, etc., and back filling; tender C—for the erection of pole line; tender E—for the supply, delivery and erection of motors, pumps, piping and air compressor. Tender F—for the supply and delivery of poles, wires, line material, etc.

Catalogues

The Lumen Bearing Co., West Toronto, Ont., have issued a dainty booklet on die castings, which are made in Lumen bronze babbitt metals, and spe-

cial alloys of tin lead and zinc. Casting a player piano valve, telephone receiver saddle, telephone ringer bracket, a spiral gear and a typewriter bracket are described, with full page illustrations. The matter of making die or pressure castings is dealt with at length.

A New Paper Mill Engine is the title of a 16-page pamphlet, size 6 x 9, recently issued by the American Engine Co., Bound Brook, N.J. This pamphlet describes and illustrates the new American ball four-cylinder paper mill engine. Engines of this design have a wide speed range—that is, 8-1 and even 10-1, and may therefore be coupled directly to the variable speed shafting without immediate belts and pulleys for speed changing. The second feature of this engine is the especially designed American ball speed control mechanism. This comprises two governors—one an automatic engine stop and the other the variable speed governor, and also a friction device for changing the speed of the variable speed governor. For paper mill service it is very essential that speed surges be eliminated, because sudden changes in speed cause uneven thickness of the paper as well as breakage of thin delicate paper. Besides describing and illustrating the American ball four-cylinder mill engine, drawings are also shown of the two cylinder angle type speed engine, also of the two-cylinder horizontal variable speed paper mill engine. Copies of the pamphlet may be had on application to the American Engine Co., of Bound Brook, N.J.

"Is There Rosin in Cling-Surface?" is the name of a new 12-page booklet just issued by the Cling-Surface Co., Buffalo, New York. To prove that there is no rosin in this belt preparation the manufacturers show several fac-simile reports of chemical analyses made in England and Germany. Professor Orudorf, of Cornell University, is also quoted. The booklet lists many prominent users.

Noiseless Gear Driving.—A 56-page book issued by the New Process Gear Corporation, Syracuse, N.Y. It contains sound engineering arguments for rawhide gears, proves that they are of important economic value in any plant where high speed gears are used, gives much transmission data, and is profusely illustrated with photographs of actual installations. Sections of eleven types of rawhide gears are shown, and prices on nearly 2,000 sizes of pinions are given, which are either in blank or cut and ready for use. In the back of the book a few pages are devoted to the large metal gear cutting departments of the above company. A free copy will be mailed on request.

The United States Electrical Tool Co., Cincinnati, O., have favored us with a copy of catalogue "H." It deals fully with electrical hand or breast drills, electric radial drills, bench drills, electrically driven grinders, etc. These are machines which may be taken to the work, and the lamp socket is the only power house required. Space cannot be given here to tell of the excellent photographs in this catalogue, showing how these tools may be used as time-savers. At the end are general instructions on how to take care of electric tools. The uses to which electric tools may be put are so many that no one should be without this booklet.

Neptune Belting gets its name from the fact that it is especially adapted for damp and wet places. Some people use cotton or rubber belts in damp places, but it is claimed by makers of "Neptune" that it will outlast three belts of rubber or cotton. It has been run in rain, snow and sun, submerged in water for hours at a time, and frozen solid, yet the laps did not loosen, nor did the belting come apart between the plies. It is made by the Graton & Knight Mfg. Co., Worcester, Mass.

BRITISH RAILWAY ACCIDENTS.

RETURNS have just been issued of accidents on British railways during 1912. From these it appears that fatal accidents to passengers in trains resulted in 20 deaths, while there were also 683 injuries. These figures are higher than the records for 1911, in which there were 14 passengers killed and 468 injured. The total number of passengers killed on the railways as a result of the movement of trains and vehicles was 110, and 2,829 were injured. Many of these accidents, of course, are due to no fault in railway working, but to the carelessness of passengers themselves, such as jumping on and off trains in motion, falling out of carriages and between carriages and platforms, etc.

The fatal accidents to employees showed a decrease in 1912 on the figures of 1911. There were 343 employees killed last year, compared with 390 in the year before. The number of injured increased, however, from 5,311 in 1911 to 5,562 in 1912. The casualties resulting from accidents to trains, as well as those from other accidents connected with other movements of vehicles, both showed an increase on the previous year. The grand total of passengers, employees, and others killed on the railways was 1,011, or 59 less than in 1911, while the injured amounted to 8,700 persons, or 355 more than in 1911. These totals, of course, include tres-

passers, suicides, etc., for which the railways are in no way responsible.

Out of 867 "other persons" killed and injured, no less than 344 were trespassers and 241 suicides. Very often when these accident returns are noticed, no trouble is taken to discriminate between the classes for which the railways may be and should not be held responsible, and the returns naturally appear unduly high. The train accidents, however, last year were above the average.



TO ENCOURAGE SHIPBUILDING IN CANADA.

DURING a recent afternoon sitting of the House of Commons at Ottawa, an interesting discussion arose over the item of one million dollars for maintenance and repairs to Government steamers and ice breakers. Hon. Mr. Lemieux asked if the ships to be procured would be built in Canada.

The Hon. Mr. Hazen stated that experience had shown that contracts let in Canada had not been delivered on time, whereas when contracts were let to firms of established reputation, in Britain, such conditions did not occur. Tenders from the other side of the water were much lower. It would, however, be quite fair, said the Minister, to ask that tenders awarded to British firms should be carried out in Canada, and that firms should establish yards in Canada where the ships would be built.

Ice-breakers to be Built Here.

Referring to ice-breaking on the St. Lawrence, the Minister of Marine spoke of the effective work carried out by the Montcalm and Lady Grey. In the vote before the House, he said, the Marine Department was asking for \$250,000 to procure a modern and powerful ice-breaker for the St. Lawrence River. This was most necessary in order to open navigation to Montreal earlier in the spring.

The Hon. Mr. Lemieux asked if this boat would be built in Canada, and Mr. Hazen replied that he believed such was the intention.

Mr. Lemieux was glad to hear of this addition to the flotilla of ice-breakers. At first there had been a prejudice against these boats at Quebec on account of the work done at Cape La Roche, but good results had followed in the prevention of floods as far as Three Rivers and Lake St. Peter. The member for Rouville again touched on the question of shipbuilding in Canada, and asked the Minister to give it encouragement even if, at first, prices were somewhat higher. He referred to Vickers, Limited, at Montreal, and expressed his belief that Maissonneuve would yet become a great shipbuilding area.

SELECTED MARKET QUOTATIONS

Being a record of prices current on raw and finished material entering into the manufacture of mechanical and general engineering products.

PIG IRON.

	Per Ton.	
Foundry No. 1 and 2, f.o.b., Midland	\$19 00	\$19 50
Gray Forge, Pittsburg	16	15
Lake Superior, charcoal, Chicago	18	00
	Mont'l. Tor'to.	
Canadian f'dry, No. 1..	\$21 00	\$20 00
Canadian f'dry, No. 2..	20 50	19 50
Middlesboro, No. 3....	23 50	23 50
Summerlee, No. 2	25 00	26 50
Carron, special	25 00
Carron, soft	25 00
Cleveland, No. 1	24 25	25 00
Clarence, No. 3	23 75	24 50
Jarrow	25	50
Glengarnock	26	00
Radnor, charcoal iron.	30 00	34 50
Ferro Nickel pig iron (Soo)	25	00

BILLETS.

	Per Gross Ton.	
Bessemer billets, Pittsburgh	\$28	50
Open hearth billets, Pittsburgh.	29	00
Forging billets, Pittsburgh.....	36	00
Wire rods, Pittsburgh	30	00

FINISHED IRON AND STEEL.

Per pound to large buyers:

	Cents.
Common bar iron, f.o.b., Toronto..	2.10
Steel bars, f.o.b., Toronto.....	2.20
Common bar iron, f.o.b., Montreal.	2.15
Steel bars, f.o.b., Montreal.....	2.25
Bessemer rails, heavy, at mill....	1.25
Iron bars, Pittsburgh	1.70
Steel bars, Pittsburgh, future	1.40
Tank plates, Pittsburgh, future...	1.45
Beams, Pittsburgh, future	1.45
Angles, Pittsburgh, future	1.45
Steel hoops, Pittsburgh	1.60

Toronto Warehouse f.o.b., Toronto.

	Cents.
Steel bars	2.30
Small shapes	2.45
Warehouse import, freight and duty to pay:	Cents
Steel bars	1.95
Structural shapes	2.05
Plates	2.05
Freight, Pittsburgh to Toronto:	
18 cents carload; 21 cents less carload.	

BOILER PLATES.

	Mont'l. Tor'to.	
Plates, ¼ to ½-in., 100 lbs.	\$2.35	\$2.35
Heads, per 100 lbs.....	2.65	2.95
Tank plates, 3-16 in.	2.60	2.60
Tubes, per 100 ft., 1 inch	9.00	8.50
" " 1¼ in.	9.00	8.50
" " 1½ "	9.00	9.00
" " 1¾ "	9.00	9.00
" " 2 "	8.75	8.75
" " 2½ "	11.50	11.50
" " 3 "	12.00	12.00
" " 3¼ "	13.75	13.75
" " 3½ "	14.50	14.50
" " 4 "	18.00	18.00

BOLTS, NUTS AND SCREWS.

	Per cent.
Stove bolts	80 & 7½
Machine bolts, ¾ and less	65 & 5
Machine bolts, 7-16.....	57½
Blank bolts	57½
Bolt ends	57½
Machine screws, iron, brass	35 p c.
Nuts, square, all sizes.....	4c per lb off
Nuts, Hexagon, all sizes..	4¼ per lb off
Flat and round head.....	35 per cent.
Fillister head	25 per cent.
Iron rivets	60, 10, -0 off
Wood screws, flathead, bright	85, 10 p c off
Wood screws, flathead, brass	75, 10 p c off
Wood screws, flathead bronze	70, 10 p c off

National-Acme "Milled Products."

Sq. & Hex Head Cap Screws	65 & 10%
Sq. & Hex Head Cay Screws	65 & 10%
Rd. & Fil. Head Cap Screws	45-10-10%
Flat & But. Head Cap Screws	40-10-10%
Finished Nuts up to 1 in. . .	75%
Finished Nuts over 1 in. . .	72%
Semi-Fin. Nuts, up to 1 in...	75%
Semi-Fin. Nuts over 1 in....	72%
Studs.....	65%
Discounts f.o.b., Montreal.	

WROUGHT IRON PIPE.

The following are Toronto jobbers' discounts on pipe in effect from April 21, 1913:

	Buttweld		Lapweld	
	Standard	Black Gal.	Black Gal.	Gal.
¼ ¾ in.	62	47
½ in.	68	58
¾ to 1½	71½	61½	68½	58½
2 in.	71½	61½	68½	58½
2½ to 4 in. . .	71½	61½	70½	60½
4½ to 6 in.	71½	61½
7, 8, 10 in.	66	54

X Strong P. E.

¼, ⅜, ½ in. . .	56½	46½
¾ to 1½ in. . .	67½	57½
2 to 3 in.	68½	58½
2½ to 4 in.	65	55
4½ to 6 in.	64	56
7 to 8 in.	55	45

XX Strong P. E.

½ to 2 in.	43	33
2½ to 4 in.	43	33

PRICES OF WROUGHT IRON PIPE.

Nom. Diam. per ft.	Standard. Price.	Extra Strong. Size Ins. per ft.	Ex. Strong. Size Price Ins. per ft.
½ in	\$.05½	½ in	\$.12 ½ \$.32
¾ in	.06	¾ in	.07½ ¾ .35
⅝ in	.06	⅝ in	.07½ 1 .37
½ in	.08½	½ in	.11 1¼ .52½
¾ in	.11½	¾ in	.15 1½ .65
1 in	.17½	1 in	.22 2 .91
1¼ in	.23½	1¼ in	.30 2½ 1.37
1½ in	.27½	1½ in	.36⅓ 3 1.86
2 in	.37	2 in	.50⅓ 3½ 2.30
2½ in	.58½	2½ in	.77 4 2.76
3 in	.76½	3 in	1.03 4½ 3.26
3½ in	.92	3½ in	1.25 5 3.86
4 in	1.09	4 in	1.50 6 5.32
4½ in	1.27	4½ in	1.80 7 6.35
5 in	1.48	5 in	2.08 8 7.25
6 in	1.92	6 in	2.86
7 in	2.38	7 in	3.81
8 in	2.50	8 in	4.34
8 in	2.88	9 in	4.90
9 in	3.45	10 in	5.48
10 in	3.20
10 in	3.50
10 in	4.12

IRON PIPE FITTINGS.

Canadian malleable, 40 per cent.; cast iron, 65; standard bushings 70; headers, 60; flanged unions, 65; malleable bushings, 65; nipples, 75; malleable, lipped unions, 65.

COKE AND COAL.

Solvay Foundry Coke	5.95
Connellsville Foundry Cob	5.45
Yough, Steam Lump Coal.....	3.83
Penn. Steam Lump Coal	3.63
Best Slack	2.95
All net ton f.o.b. Toronto.	

OD MATERIAL.

	Tor'to.	Mont'l
Copper, light.....	\$12 05	\$11 00
Copper, crucible	15 00	13 50
Copper, unrefined, heavy	13 05	12 50
Copper wire, unrefined..	13 05	12 50
No. 1 machine compos'n..	12 00	11 00
No. 1 compst turnings..	10 00	10 00
New brass cappings	9 15	9 10
No. 1 brass turnings	8 30	7 75
Heavy lead	3 25	3 75
Tea lead	3 00	3 00
Scrap zinc	4 00	3 75

Dealers' purchasing prices.

METALS.

Prices in cents per pound:

	Mont'l.	Tor'to.
Lake copper	16.00	16.00
Electrolytic copper	16.00	16.00
Spelter	6.00	5.75
Lead	4.70	5.15
Tin	50.00	48.50
Antimony	10.00	9.75
Aluminum	21.00	21.00

SMOOTH STEEL WIRE.

No. 6-9 gage, \$2.35 base; No. 10 gage, 6c extra; No. 11 gage, 12 extra;

No. 12 gage, 20c extra; No. 13 gage, 30c extra; No. 14 gage, 40c extra; No. 15 gage, 55c extra; No. 16 gage, 70c extra. Add 60c for coppering and \$2 for tinning.

Extra net per 100 lb.—Spring wire; bright soft drawn, 15c; charcoal (extra quality), \$1.25.

SHEETS.

	Mont'l.	Tor'to.
Sheets, black, No. 28....	\$2 85	\$3 00
Canada plates, ordinary,		
52 sheets	2 80	3 00
Canada plates, all bright.	3 70	4 15
Apollo brand, 10¾ oz.		
(American)	4 30	4 20
Queen's Head, 28 B.W.G..	4 50
Fleur-de-Lis, 28 B.W.G..	4 20
Gorbals Best Best, No. 28	4 45
Viking Metal, No. 28....	4 40

NAILS AND SPIKES.

Standard steel wire nails,		
base	\$2 40	
Cut nails	\$2 60	2 65
Miscellaneous wire nails..	75 per cent.	
Pressed spikes, ⅝ diam.,		
100 lbs.	2 85

FINE STEEL WIRE.

Discount 25 per cent. List of extras. In 100-lb. lots: No. 17, \$5; No. 18, \$5.50; No. 19, \$6; No. 20, \$6.65; No. 21, \$7; No. 22, \$7.30; No. 23, \$7.65; No. 24, \$8; No. 25, \$9; No. 26, \$9.50; No. 27, \$10; No. 28, \$11; No. 29, \$12; No. 30, \$13; No. 31, \$14; No. 32, \$15; No. 33, \$16; No. 34, \$17. Extras net. Tinned wire, Nos. 17-25, \$2; Nos. 26-31, \$4; Nos. 30-34, \$6. Coppered, 75c; oiling, 10c.

MISCELLANEOUS.

	Cents
Putty, 100 lb drums	\$2.70
Red dry lead, 560 lb. casks, per	
cwt.	6.00
Glue, French medal, per lb	0.10
Glue, 100 flake	0.11
Tarred slaters' paper, per roll...	0.95
Motor gasoline, single bbls., gal..	24½
Benzine, per gal.	23½
Pure turpentine	63
Linseed oil, raw	58
Linseed oil, boiled	61
Plaster of Paris, per bbl.	2.10
Plumbers' Oakum, per 100 lbs....	3.25
Pure Manila rope	17

The General Market Conditions and Tendencies

This section sets forth the views and observations of men qualified to judge the outlook and with whom we are in close touch through provincial correspondents.

Montreal, June 2, 1913.—Buoyancy still is the dominant feature of the machine tool market; that is, most of the dealers feel "it is coming" to use a common expression. The railways are on the eve of big purchases and some orders are pending that will be worth recording when they do evolve. The big steel mills are all active, and a prominent official of the Dominion Iron & Steel Co. stated the other day that their plant was running night and day on steel rails, tacks, nails and bar iron. He expressed regret that the laws of Sydney would not permit them to run on Sunday. Their annual meeting takes place this month. Mr. Plummer, the president, has just returned from the Old Country, and it is understood that the Corporation's finances are in good shape, and the expansion of the plant will take place at once.

Pig Iron, Coke, Copper.

Pig iron is still declining, and the output in big centres is reported to be of a record-breaking character. Consumers are conservative, and yet it can be noted by wise ones that the last half of the year will see some keener interest in this product. Machine shops, locomotive works and pipe works, also jobbing founders seem to be the principal buyers now in the market. The

decline has not stimulated buyers to any pronounced action. Furnace interests will be the factors, when the activity of real buying sets in. So we are told. The prices now current might easily be shaded and still be stiff enough to be correct. Coke has been moderately active and steady, and plenty of orders are being given for second half of year's contracts at good prices. Copper declined noticeably this week everywhere. In the Old Country, a drop of ten shillings was reported and about an eighth of a cent per pound on this continent. Considerable enquiry towards the end of the week, chiefly from consumers, kept the market firm. Reports from abroad state that Europe is ceasing to consume the enormous shipments that are pouring steadily there and we have it on good authority, that one large European house who are agents for a large American firm have in their holdings about 75 per cent. of the copper now warehoused in Britain and France, which places the control of the market in the hands of these operators. Reports from Pittsburg state that large buyers declare that pig iron prices will drop steadily until at least a full dollar a ton is cut off present quotations. The low stocks of buyers do not bear out this prediction.

Metals and Old Material.

More fluctuations were in evidence in the tin market, but it is believed that the changes have been due almost entirely to speculative operations. The whole month of May was a busy one for tin, shipments have been heavy to this continent and the consumption quiet. Quotations for July and August were slightly lower, but are not sufficiently important to change our figures. Antimony is still dull and aluminum also is quiet and uninteresting. Old material weakened, and is lower, owing again to the large supplies and the small demand.

Toronto, June 4, 1913.—Dealers who are selling machinery these days are working mighty hard, yet the business put through does not amount to a great lot. Very few big deals are made. A representative of the Canadian-Fairbanks-Morse Co., reports business picking up around Cobalt, following the settlement of the strike. The machinery tool equipment for the new Toronto Technical Schools was purchased this week.

Pig Iron and Steel.

It is difficult to get down to the facts when no business is being done. There are no facts, except that things are unduly quiet. Some may say this is a naturally slack period of the year in the steel trade. Yes, but the business being done by one of the largest dealers in iron and steel in Ontario is 50 per cent. less than is customary at this time of the year. Prices are not likely to

Simonds Hack Saws

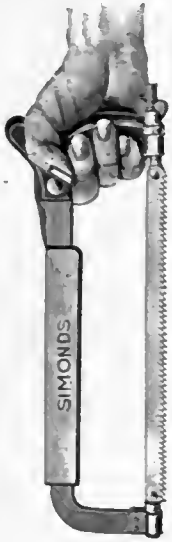

There are people in every community who want things a little better than the average of the other people. To this trait in human nature do we attribute our success with Simonds Hack Saw Blades. We sell blades and frames direct to you.

Simonds Canada Saw Company
Limited
MONTREAL, QUE.

St. John, N.B. Vancouver, B.C.
In the United States, Simonds Mfg. Co.

change until the mills have caught up with their orders. When this takes place, and quick delivery can be guaranteed from mill instead of warehouse, then a change in price may occur. At present the mills are as busy as ever. A dealer in iron and steel remarked this week that he expected this dullness to continue for three weeks more at least.

Metals.

Those who require metals these days buy carefully, getting just sufficient to carry them over. While things are quiet, business in the metal market is on a level with that done last year, and perhaps the amount is slightly better. The worst months were February, March and April, and dealers say prospects for June and July are not by any means bad. Tin is \$48.50, while last week it was \$51.00. Aluminum is slow, and the tendency is for it to drop lower. It is offered freely, but there are no buyers. There is plenty of copper offered, and the demand is good, but the margin is so small it is hardly worth handling. There are fairly large inquiries for old material, and plenty is being offered dealers.

St. John, N.B., June 2, 1913.—The moulders in the Enterprise and Fawcett stove foundries at Sackville, N.B., are on strike, more than 100 men being affected. The demand is for an increase of 10 per cent. in piece work rates and a minimum wage of \$3 a day. The employers have thus far refused the request.

A party of about twenty-five hardwaremen and lumber dealers are expected to visit the city in a few weeks from Montreal and other Upper Canadian cities. They will inspect the oil shales in Albert County, and will then come here to look into the development of local industries.

Woodstock, N.B.—The buildings of the Dunbar Foundry and Machine Shop at Woodstock, N.B., were destroyed in part this week by fire. They were practically new, and the damage which resulted will hinder the progress of the company to a considerable extent. Reconstruction will be started at once.

McAdam, N.B.—The contract for the new machine shop to be erected at McAdam, N.B., by the C. P. R. has been awarded to Henry Post, of Woodstock. Other improvements will be made in the near future to the large plant already located there, and these with the amount for the new machine shop will total about \$100,000. The structure will be of steel and concrete, and machinery of the latest type will be installed. Three miles of 85-pound rails are to be laid, the new rails on this division being heavier than those now in use.

Patent Attorneys

TRADE MARKS, COPYRIGHTS & DESIGNS
PATENTS
LLOYD BLACKMORE & COMPANY
LUMSDEN BUILDING, TORONTO.
ALSO, HOPE BLDG. OTTAWA & WASHINGTON, D.C.
We have an interesting and valuable booklet "PATENT PROTECTION" which will be sent free upon request.

PATENTS
PROMPTLY SECURED
in all countries. Ask for our Inventor's Adviser, which will be sent free.
MARION & MARION, 364 University St.
Merchants Bank Building, corner St. Catherine St., MONTREAL, Phone Up 6474 and Washington, D.C., U.S.A.

PATENTS
PIGEON, PIGEON & DAVIS
71A, ST. JAMES STREET, MONTREAL
Phone, Main 3025

Pattern Makers

PATTERNS
WOOD AND METAL
Allow us to estimate. Satisfactory work guaranteed.
TAYLOR PATTERN WORKS WALKERVILLE, ONT.

PATTERNS OF EVERY DESCRIPTION
SATISFACTION GUARANTEED
POTTS PERFECT PATTERNS
PHONE ADELAIDE 103
R. POTTS
87 RICHMOND ST. W., TORONTO.

The CONTINENTAL HOTEL

Chestnut Street, Corner of Ninth
PHILADELPHIA

Remodeled, Refurnished,
400 Rooms. 200 With Bath.

Rates: \$1.50 to \$5.00

European Plan

The Best Cafe in the City

Frank Kimble,
Manager

METAL STAMPINGS

We are manufacturers of stamped parts for other manufacturers. We do any kind of sheet metal stamping that you require. Our improved presses and plating plant enable us to produce the finest quality of work in a surprisingly short time. We can finish steel stampings in Nickel, Brass or Copper. Send us a sample order.

W. H. BANFIELD & SONS
120 Adelaide St. W., Toronto

A want ad. in this paper will bring replies from all parts of Canada.

Overhead Expense Distribution in Manufacturing*

By Royal R. Keely

Cost accounting and the establishment of cost records are prominent features of every well conducted industrial enterprise of our time. We are not sure, however, that their real purpose is always achieved. The different questions discussed by the Author of the Paper, indicate directions in which to secure data relative to standard cost of each item of product.

ALL outlay in any industry may be divided into three broad classes—labor, material, expense; or more broadly, direct and indirect expense. Direct expense may be defined as that which may be charged directly to the product; indirect expense as all other expense connected with the conduct of the business, and which must be borne by the sale of the product. In a foundry, for example, the labor applied directly in producing a length of cast-iron water pipe is called direct labor expense; that is, it is the labor applied directly to the product of this piece of pipe, and is in no way related to other articles that may be produced. The pig iron required in making the length of pipe is direct stores expense. Other labor connected with the administration or supervision is classed as indirect expense. Stores required for repair of building and equipment, office supplies, etc., are classed as indirect stores expense.

In order that the management may intelligently conduct any business, the cost of each article of product should be known. In determining the cost of the length of cast-iron pipe referred to, the labor applied directly in making it, as for instance, the setting up of the mold, pouring of the metal, removing of the pipe from the mold and cleaning it of sand, etc., and the pig iron entering into it, may be charged directly to its cost. Since, however, all expense of the conduct of the business must be borne by the product, this individual length of pipe must bear its share of the charges for supervision, taxes, insurance, depreciation, repairs, heat, light and power, selling and advertising, general office expense, etc.

A Controversial Topic.

The determination of just what its share of these expenses should be has aroused much controversy, and there are in use to-day six methods of determining this indirect or overhead expense:

(a)—In proportion to material used; (b)—in proportion to the direct labor charges; (c)—the time or number of man-hours employed in production; (d)—machine rates; (e)—cost numbers or factors; (f)—prorating by inspection or judgment.

The first of these may be satisfactory if the product is homogeneous, as brick from a brickyard, where if any one kind of brick constitutes one-tenth the product of the plant, this will take one-tenth of the total overhead expense.

The second, that of apportioning expense according to wages paid, is very generally used. Here, if the direct wages paid on any kind of cast iron pipe are one-tenth the total direct wages for the foundry, then this kind of pipe bears one-tenth of the total overhead expense. The objection to the method is that a job produced by a 40-cent man at a vise and bench would bear the same proportion of overhead expense as one produced by the same man on a large and very expensive machine. This method will be sufficiently accurate only in cases where the workplaces are all of nearly equal value and capacity, and the workmen paid fairly uniform wages.

By the third method overhead expense is apportioned by the time spent on the job, instead of the value of the time, as in (b). It does not take account of the equipment.

Workplace Hour Method.

In the machine hour, or the workplace hour method, the rate is figured to include all expense of maintaining and operating the given workplace, a term broad enough to include everything, from an allotted area where a man may work with a monkey wrench or paint brush to the most complicated and costly machine in the shop.

In a modern office building, the income-bearing unit is the office room to be rented, and in fixing the rental, account must be taken of all the overhead expense. In a machine shop, each workplace may be regarded as enclosed by four imaginary walls, forming a room of suitable size for the performance of its operation. Each workplace is then considered as a unit in itself from which profit may be made in turning out a product, or it may be rented to an individual workman. If all the workplaces are rented, then the source of income is not on product sold, but altogether from rental on the available useful space of the manufacturing plant. All space, however, cannot be turned into rentable workplaces, for there must be general heat, light and power plant, storage space, aisles, halls, passages,

offices, etc. The rented space, therefore, must not only maintain and operate the entire shop, but must produce a profit for the owners. Each workplace unit must bear its share of interest and depreciation on its building, interest and depreciation on the cost of machine, taxes, insurance, etc., on the investment, repairs and maintenance of building and equipment, its share of heat, light, power, etc., as well as all other general charges, if it is to make a profit for its owners.

The cost of the product from each workplace is made up of rental, raw material entering into the product, and a fair compensation for the worker, and the selling price must include his profits. The rental of each workplace must be a figure that will enable its operator to make a profit and must at the same time pay all the owner's expenses and make a profit besides. Provision must also be made for the idle time of a workplace. This indicates the method of arriving at the machine rate. The method is superior to the others in that it takes account of the variation in the cost of production on different types of workplaces, and would be accurate if there were no idle hours. In any system the wages are very carefully charged directly to the item of product, but since the general charges of interest, depreciation, insurance, etc., may be equal to or greater than the wages, it is important to cut these down to a minimum by putting as great a proportion as possible directly against the particular items of product, as in this method.

Supplementary Rate Provision.

Mr. Church, in his book on Expense Burden, advocates a supplementary rate to dispose of the expense connected with the idle hours and the auxiliary departments, as shipping room, store room, etc. By this plan, expenditure is connected with production centres, the charges being debited to jobs by machine rents or rates so carefully arranged as to include all of them. All floating or general items are collected into a monthly shop-charges account, which is relieved by the total of charges which have been debited during the month by means of machine rates, leaving in the account a residual sum. This sum is reduced by the supplementary

*From a paper read before the A.S.M.E. at Philadelphia, on February 8.

rate to an hourly burden, distributed over the jobs in the usual way.

To quote from Mr. Church himself: "It will be obvious that by this means all the charges will be distributed, leaving nothing in the charges account, and that if all the machines have made full time in the month, the supplementary rate will only represent the floating shop charges. In proportion as machines are idle, the supplementary rate will rise, because only working hours are credited to the shop account as per the total of the machine rates found at the end of the month. Thus we secure that each job gets its own expenses only attached to it, plus an average of floating charge and of what surplus may be due to slack time or inefficiency in the shop."

Again he says: "The idleness of a machine may or may not be considered as the fault of that machine. If, for instance, a machine was found to be idle nineteen-twentieths of its time, this might be due to one of two causes. Either the process was rare, but essential, or the machine itself was largely superfluous. In the first case, it would be eminently fair that the charge should be made very high when it was put in use, since the shop charges due to its presence and upkeep are indubitably incurred for the sake of this occasional use. In the second case, it might be rather a matter of accommodation that the machine was retained at all, in which case the shop as a whole should bear the burden, and not the unlucky piece of work that should happen to be put on such machine at that time." It is thus seen how this ingenious method puts to each item of product its proper share of overhead charges for the workplaces which are in use. Then the balance left over, due to idle machines and other auxiliary and general expenses, is prorated by a supplementary rate.

Cost Numbers or Factors.

In the fifth method, that of cost numbers or factors, which is a simpler system worked out by Frederick W. Taylor in his study of scientific management, the machine rates are determined by a process similar to that already described, and the rates are then treated not as a figure of value, but as a relative number called "relative cost numbers," or simply "cost numbers." If the cost of maintaining and operating two machines is three cents and three dollars per hour respectively, the cost numbers will be three and three hundred respectively. The number of hours each machine runs on any job is multiplied by its cost number. At the end of the period the total hours by cost numbers for each article or class of product on which it is desired to compute costs and also for the entire shop, are

added together. The result obtained is about the same as that reached by Mr. Church's method, without the complication and extra work of apportioning a second time for the supplementary rate.

In general, a rate for apportioning the overhead expense can be established by this method for any class of product and the variation of the rate from period to period will give an accurate indication of the percentage of idle time in connection with this product. The disposal of all shop expense is now provided for. There will be few difficulties in the way of putting the direct labor and store charges against the article of product into which it enters.

Direct Labor and Stores Charge.

The writer generally accomplishes this result by assigning to the product and stores a definite, concise symbol for each size and kind. The mnemonic system of symbolization, as developed by Mr. Taylor, gives most excellent results. All expense in connection with the conduct of a business is divided into (a)—auxiliary or (A) accounts, as power, stores, shipping, planning, etc.; (b)—business office or (B) accounts; (c)—sales department or (C) accounts; (d)—manufacturing departments or (D) accounts; (e)—machinery and equipment or (Y) accounts; (f)—real estate or (Z) accounts.

The expenses in connection with the (A), (D), (Y) and (Z) accounts are shop expenses, and are disposed of by the method of hours by cost numbers, already described. (B) and (C) have no direct relation to shop costs, and the expense of these departments may be disposed of by another method to be considered presently. All labor is apportioned by a system of job cards, time stamped at the beginning and again at the end of the job. The sum of the time shown on all these cards must equal the time for which the workman is paid. There is only one job on a card, and each card bears the symbol of the product to which the time is charged. The stores are issued from the store room on similar cards. During the period all job cards and stores issue cards are accumulated by symbol in a card index file. At the end of the period the total of all money paid, as represented by the cards, is drawn off by products.

In the classification of expense, there is a symbol for each item, both direct and indirect, the direct labor and stores being entered at once on the cost card for product turned out, while the indirect labor and stores are entered on expense distribution cards, together with other indirect charges, as taxes, insurance, depreciation, etc.

The selling and business office expense (B) and (C) may be apportioned

by a different method, either by direct shop cost, by wages, or by the time consumed in the manufacture of the product, according to the nature of the business. In some cases it may, be merged with the shop expense and the total prorated by the method outlined. The usual method is by direct labor cost, or by hours of labor consumed in production.

Inspection or Judgment Method.

The sixth method of apportioning the overhead expense, i.e., by inspection or judgment, is one in which the experience and judgment of officials of a company are used in putting this expense where it belongs; and to arrive at a practical method for doing this, the principal items of expense, which may include advertising, catalogues, correspondence, legal expense, patents, traveling expense, salesmen's salaries, drawings, etc., are listed, and the expense of each apportioned to each class of product in proportion to the benefit derived, the proportion being determined from inspection. Thus, it may appear that advertising expense should be distributed among four different products as follows:—10 per cent. to the product (A); 20 per cent. to the product (B); 30 per cent. to the product (C), and 40 per cent. to the product (D). Product (A) may be an old and staple article, having a general demand, while (D) may be a new and patented article for which demand must be created by advertising.

If the profit on any class of product is exceptionally high or low, it will call for a careful examination of the direct and prorated charges. The direct charges of stores and labor are very definite items, and on these there can be little question. The indirect charges, especially those in connection with business administration and selling, are very intangible and hard to connect with any expense of manufacture, but it must be remembered that every dollar or expense, both direct and indirect, must be borne by the product which is made and sold.

The method of hours by cost numbers for all shop expense and that of apportioning by inspection for selling and business administration expense, are most generally applicable to the ordinary manufacturing establishment.



Forest, Ont.—The Town Council favor placing the new electric light plant on the Town Hall property, to facilitate heating the Town Hall and the Public Library. The plans include accommodation for water works pumps, run by electric motors. E. J. Philips, Brockville, Ont., is consulting engineer.

CONSERVATION OF MECHANICS.

By J. H. Rodgers.

CONSIDERABLE space is devoted in current issues of technical and trade journals to the education and training (through the medium of the trade school), of mechanics and young men to better fit or prepare them for the battle of industrial life, yet, while it is true that these schools are doing much to advance willing and industrious men and boys to a knowledge of the elements of engineering in its various branches, in the majority of cases when they enter a factory the student must start from the foot of the ladder. The general trend of industrial life to-day appears to be the elimination of the apprentice, or as is the case in some places, to use him at small remuneration as a means to an end. Little thought is given in numerous instances to the future well-fare of the boy.

Trade School Training.

Much time and large sums of money are annually spent on trade schools, in the effort to prepare young men to enter a factory with sufficient knowledge to enable them to secure and hold a job alongside of experienced mechanics. If the same amount of energy were expended by manufacturers themselves, in training and teaching the young men of to-day, better results than at present would, I am sure, be obtained.

Apprentice Treatment.

In many large manufacturing establishments, a boy (sometimes called an apprentice) secures a job at a few dollars a week, and in a short time he may be set to work to drill, mill or turn a thousand or so of a certain piece of machinery, which although simple in itself, may form one of the units that make the finished product of that particular plant. The novelty of the situation takes the fancy of the boy for a time, but if he is at all ambitious, he soon wishes for a change. He may then be given another lot of the same or similar pieces and while appearing content to continue the operation, it is not usually long before the monotonous tone of the work begins to tell on him and unsettles his nerves.

Unless the remuneration is excessive, can you blame an apprentice or a mechanic if he shows a spirit of antagonism when asked to accept, without remark, the almost perpetual ceaseless motions:—Pick up, chuck up, cut up; let up; pick up, chuck up; cut up; let up? Day after day, and week after week, the same wearying, irksome sameness—tends to make him a human automaton. Familiarity in many cases breeds contempt.

No boy, if desirous of learning a trade, should be put on piece-work until he has been thoroughly instructed in the various phases of mechanical accomplishment and skill, and this is practically impossible in the short time spent when serving an apprenticeship.

Stimulation of Thought Essential.

One of the essential factors in a boy's training is to stimulate thought, not eliminate it, as is too often the case in the modern shop. On much machine work the operator is idle at least one-half of the time, being the time when the machine is actually working and during which the man or boy must practically remain with his mind and hands unoccupied. It is safe to say that a great deal of this time is spent especially among the younger men, with the discussion of current topics, chief among them being baseball, racing and other sports. Would it not be possible to utilize some of this time to better advantage? Surely there are problems pertaining to the trade that could bear discussion during this period of inaction which would prove more beneficial to all concerned than the frivolous conversation of temporary interest which takes the mind of many men and boys from their chosen calling. Many a tool has cut "wind", and a hammer remained idle for different periods, while the merits or demerits of a certain "star player" have been discussed. While this latter circumstance might also arise if the discussion were over some design of special tool, a dividing head problem or a question of gearing, yet the time seemingly lost would be to the firm's interest, as the line of thought started by the discussion would occupy the minds of the workmen during their spare moments.

Choosing An Employee.

A firm advertise for an A1 machinist. Several applicants appear, and it is up to the superintendent or foreman to hire one of them, if in his estimation the applicant seems desirable. Should the new man prove efficient, all is well; but on the other hand, if he be not satisfactory he is dubbed an impostor, and the foreman will either discharge him or rate him so low that the man will leave anyway, and the process of securing a desirable mechanic has to be repeated. In some cases, may not the foreman be a little hasty in his judgment? Few, if any of us, are born equals, but we are each entitled to equal opportunity, and opportunity has had and still will have much to do with the success or failure of men.

The Foreman's Judgment.

A successful foreman, with executive ability, can find a plan for almost

any type of mechanic, therefore the danger of hasty judgment cannot be too strongly emphasized. Many mechanics, to-day, are misfits, that is, they do not fit properly in the niche they are supposed to fill.

The characteristics and temperament of each person are so different that suitable environment seems necessary for every individual, and while it is true that some mechanics can adapt themselves to various classes of work, others will thrive best when engaged in the performance of a task suited to their special individual temperament. Some men if given a small piece of complicated mechanism, would worry themselves sick, although perfectly at home on larger work.

Employer's Duty to The Boy.

Many of the young men of to-day blunder into jobs. Generally, those who enter factory life come from a class unable to send their children to the higher grade schools. At the age of fifteen or sixteen, the boys are compelled to start and provide for themselves, and the further development of their young and active minds must consequently be left to their superiors. Failure, therefore, on the part of the responsible parties may result in the dwarfing of a possible mechanical genius.

Superintendents and foremen, when employing a youth (especially an apprentice), should not be content just because the boy is producing a satisfactory amount of work. They should make a study of each boy, and assure themselves that he is following his proper vocation. A casual conversation between employer and employee has been the means of elevating many a man and boy to a higher position. It is doubtful to determine the quality of a clam until the shell is opened.

Encourage Opinions and Ideas.

The boy who advances an opinion or an idea to his foreman or fellow workman should always be encouraged. At first, these may appear absurd or even brainless to the experienced mechanic, but by careful moulding of the young and active mind, much can be done even with the slowest and most bungling youth. The alert mind of the young man fresh from his class books can be concentrated more readily upon many problems than that of many of us older men.

A case in mind was a somewhat difficult problem in gearing, which several mechanics with considerable experience had tried in vain to solve. A quiet and undemonstrative youth of less than a year's experience came along, and in a few moments had the required an-

swer; not from practical experience, but from the general rule of proportion not yet forgotten.

Feature an Active Mind.

Keep the young minds busy. Do not wait until some problem requires solving. Place them difficulties that have already been met and worked out. Technical and trade papers, after being read by the office, should be placed within the reach of the boys in the shop, for it is not the privilege of many of the younger boys to be subscribers to a trade journal, and much benefit would surely be derived by a perusal of their pages. Criticism has been the stepping stone to many a valuable invention.

Employers' Duty to Train Mechanics.

Some manufacturers are dissatisfied with the quality of mechanics they are sometimes forced to employ, yet they are not content to sit quietly and let others train men to do their special work. Train your own men, should be your slogan, and see that your foreman are making the most of the material they have in hand. The apprentices should have special attention. Make as many as possible good all around mechanics, so that they will prove a credit to themselves and be able to hold their own anywhere. Do not restrict your instruction with the thought that they will leave you after all your trouble and expense. Some may, but others will remain, and more than repay for the loss sustained.

If it be necessary to train more good mechanics for future industrial development, and no collective plan by the manufacturers can be adopted, it remains for each shop separately to perform its part, forgetting the thought that they are training mechanics for the benefit of someone else.

ONTARIO STEEL PRODUCTS CO. CHARTER.

THE Ontario Steel Products Co., of Ojibway, near Sandwich, Ont., the new Canadian branch of the United States Steel Corporation, has taken out Federal incorporation. The authorized capital stock is \$20,000,000, and the letters patent give the company wide powers regarding agreements with any other company in Canada for the purpose of pooling or combining interests.

The clause to this effect authorizes the company to enter into partnership or any arrangements for sharing profits, union of interests, co-operation, joint adventures, reciprocal concessions, or otherwise, with any person or company carrying on or engaged in, or about to carry on or engage in, any business or transaction, which this company is authorized to carry on or engage in, or any busi-

ness or transaction capable of being conducted so as directly or indirectly to benefit this company; and to lend money to guarantee the contracts, bonds, debentures and other obligations of, or otherwise acquire shares and securities of any such company, and to sell, hold re-issue, with or without guarantee, or otherwise deal with the same.

BREAKING OFF TOOL BITS.

By D. A. H.

WITHOUT considering it as an uneconomical practice, many shops run a risk of injury to workmen when they permit bars of alloy steels to be broken off cold in a vise. The method commends itself because of its speed, and quantities of tool holder bits are "made" in this way. There is, however, a safe way of doing this, and it is so simple and quick that there is no excuse for running any risk of flying particles. Use a large monkey wrench to break off the piece, and lay a bag, a piece of burlap, or an overall "jumper" over the wrench jaws and projecting length of steel.

CANADIAN RAILROAD CONSTRUCTION.

PROJECTED railroad construction in Canada is shown by the following list of subsidies recently granted by the Dominion Parliament. \$15,640,000 to the Canadian Northern Railway for lines from Ottawa to Port Arthur, Edmonton to British Columbia, and \$1,600,000 from Toronto to Ottawa. The Temiskaming & Northern Ontario Railway is subsidized \$6,400 per mile in lines from North Bay to Cochrane, Englehart to Charlton, Cobalt to Kerr Lake, Iroquois to Timmins, Earlton to Elk Lake, Iroquois Station to Iroquois Falls, a total distance of 338 miles. Other subsidies at \$6,400 per mile are to the Margaree Coal & Railway Co., 46 miles; Northern New Brunswick Railway, 16 miles; Tobique & Campbelltown Railway, 28 miles; St. John & Quebec Railway, 200 miles; Lotbiniere & Megantic Railway, 95 miles; Little Nation Railway, 30 miles; Erie, London & Tilsonburg Railway, 45 miles; Alberta Central Railway, 70 miles; Kettle Valley Railway, 335 miles; Calgary & Fernie Railway, 100 miles; for bridge over Burrard Inlet, \$350,000 and for Canadian Pacific Railway, Gimli to Yolandic river, 30 miles.

Thomas J. Drummond, president of the Lake Superior Corporation, is seriously ill in Montreal.

REMOVING A TIGHT ARBOR.

By D. A. Hampson.

HOW often have we seen a man trying to remove a stuck arbor from a milling machine by driving it out. Of course, this would not occur with a draw-in type of machine and arbor. Usually our friend gets his heaviest hammer—a pound and a half—and a rod of soft steel, which he pushes, just as it is, into the hole. Then he drives. After five minutes of hammering, he pulls the rod out and looks it over, finding that the inside is burred up and the hammer end is considerably "broomed," but the arbor remains, and it is a safe bet that its end is also burred and swelled. He tries again, and possibly keeps on, with a little good advice from the boys, until by some accident the arbor falls out. If he hasn't knocked paint off the machine, or a chunk from the feed pulley, and hasn't banged his hands, or consumed over fifteen minutes of time, he may be considered lucky—and, oh, yes, the end of the arbor does have to be re-centred and burred off.

Now, if instead of all these harrowing details, our man had considered a moment. Except in the most extreme cases that arbor can be taken out easily in five minutes. Secure a piece of steel as large as will go through the hole in the spindle, square off one end in the chuck and round the other end slightly. Get a heavy hammer from the blacksmith—an eight, or, better still, a sixteen pound—and you are ready for business. In nine cases out of ten the arbor will loosen at the first blow, and you don't have to hunt up the shop's "best striker" to handle the sledge either. A moderately smart blow on the end of the rod will do the trick, and the rod being heavy with faced ends neither bends nor burrs, but transmits the force of the blow directly and over the largest possible area.

A somewhat similar kink applies to broken taps. Assume a hole drilled clear through and a tap broken off that cannot be removed by any means at hand except that of softening and drilling out. Turn the work over so that the end of the tap faces upward, and, being the original faced end of the tap, it is flat. Get a flat ended punch as short as possible, and a heavy hammer. One good blow of the hammer and the tap is out. Invariably many of the teeth of the tap break off under such treatment, and the rest cut their way through the metal. This method does not leave perfect threads in the hole, but the cases are legion where it will answer every purpose.

High Temperature Measurement, or Industrial Pyrometry

By Alpha

The writer of this article in sending it forward for publication, ventured the opinion that readers of Canadian Machinery might not perhaps be too familiar with the subject of Pyrometry, although its application is so widespread. His treatment of the constructional features of the apparatus should tend towards a clearer idea of both its service and simplicity.

DURING the last 20 years the heat-treatment department in the modern steel works has emerged from the background and taken its place in the forefront of work's departments. The infinite varieties of steel used and required at the present day have demanded that it should be so, since nearly every type of steel product, whether it be steel-casting, crank-shaft, gun forging or armor plate, requires careful and scientifically controlled heat-treatment. Such treatment is absolutely essential if the requisite physical condition of the steel, for the successful resistance of the stresses and strains, both static and alternating, is to be secured. To scientifically control the heat treatment to which any steel is subjected necessarily means that one must be able to measure high temperatures both accurately and repeatedly, and to do this, the aid of the Pyrometer must be sought.

The Pyrometer Feature.

The term "Pyrometer" may be defined as that applied to any instrument or device capable of determining temperatures above the limit of an ordinary mercurial thermometer. This limit is about 350 degrees c, or the boiling point of mercury. By filling the bore of the tube with some inert gas, such as nitrogen, then the boiling point of the mercury is raised, since the pressure of the gas, when heated, prevents boiling. By this means temperatures as high as 520 degrees C may be measured. Above 520 degrees C., ordinary glass fails, but if the bulb be made of fused silica, then 700 degrees C may be measured. This latter is the highest temperature which can be measured by the thermometer.

In 1872, Wedgwood, the famous potter, conceived the idea of making standard pieces of clay in a mould and after drying them, burning them at the temperature of the pottery kilns. He found that the higher the temperature of burning, the greater was the contraction of the standard piece, and, by having a sliding scale, he measured this contraction, and so indirectly had a measure of the heat of his kilns.

About 1820, thermo-electricity was discovered by Seebeck who found that if two dissimilar wires be joined together, top fig., and one junction be heated, then a current of electricity was set up which increased with the temperature of heating;—the foundation of the thermo-

electric pyrometer was thus laid.

A few years later, the expansion of a known quantity of gas, such as air, hydrogen or nitrogen, under suitable conditions, was found to be very regular with increase of temperature, and this is recognized to-day as the standard whereby industrial pyrometers are calibrated. The method breaks down when the enclosing vessel reaches such a temperature that it is no longer capable of preventing the diffusion of the gas through its walls. Using a containing bulb of platinum, 1,200 degs. C may be measured.

In 1862, Bystrom patented an instrument based upon Regnault's "method of mixtures" and which is used at the present day in a simplified form of water pyrometer made by Siemens.

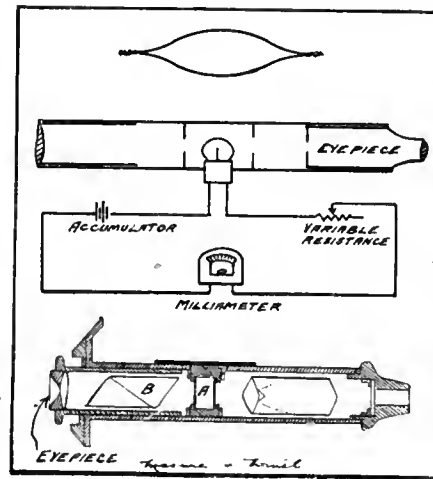

PYROMETER FEATURES.

In 1871, Siemens described a pyrometer he had made, based upon the increased resistance which a platinum wire presents to the passage of an electric current as the temperature rises, and at the present time resistance pyrometers are extensively used.

About 1860, Becquerel attempted to deduce temperature from the luminosity of a heated body. The successful development of this method has given us the numerous optical pyrometers, by whose aid temperatures far above the melting point of platinum, may be taken. Later, Fery invented a total-radiation pyrometer which was based upon the fourth-power radiation law evolved by Stefan and Boltzmann.

The foregoing are a few of the many principles upon which pyrometers have been constructed. Many others have

been tried, but pyrometers based in these are either too fragile or inaccurate to warrant inclusion in this brief resume of industrial pyrometers. Examples of the principles of Thermo-Electric, Resistance and Optical pyrometers will now be given, these being the most widely used industrially.

If two dissimilar metals such as platinum and platinum plus 10 per cent. iridium are joined together, so as to make a complete circuit, there must of necessity be two junctions, and if the temperature of one junction is raised above that of the other, then a current of electricity or E.M.F. is set up, the intensity of which is proportional to the difference in temperature of the two junctions. If, then, the E.M.F. or the strength of the current be measured with a suitable galvanometer, by simply immersing one junction (suitably protected) in a series of pure substances which are in a molten condition, and whose melting points have been determined with great accuracy by the gas thermometer, a calibration curve may be plotted by taking E.M.F. developed as abscissa and corresponding temperatures as ordinates.

The melting points of tin, 232 degs. C; lead, 327 degs. C.; silver, 962 degs. C.; copper, 1084 degs. C.; and the boiling points of water 100 degs. C.; sulphur, 445 degs. C.; and selenium, 650 degs. C., are those commonly employed for calibration. Hence, having obtained a calibration curve, the readings of the galvanometer, when one junction of the couple is in a furnace whose temperature is unknown, may at once be converted into temperature degrees.

The couple needs to be protected from contact with metals which would alloy with the platinum, and from reducing gases and hot magnetic oxide which render it brittle. This is done by enclosing in an iron or porcelain protecting tube. Other dissimilar metals which may be used, and the upper limit of temperature which may be measured by them are as follows:

Couple	Upper Limit.
Platinum and Rhodes platinum (10% RH).....	1400 degs. C.
2. Rhodes platinum alloys of different composition..	1600 deg. C.
Platinum and Iridio Platinum (10% IR)	1100 degs. C.
Nickel and Constantan ...	1000 degs. C.
Nickel and Copper	900 degs. C.

Nickel and Carbon	1000 degs. C.
Nickel and Iron	1000 degs. C.
Iron and Constantan	1000 degs. C.
Copper and Constantan ..	800 degs. C.
Silver and Constantan ...	800 degs. C.
2 Nickel-Chrome Alloys of different composition ..	1350 degs. C.

The above table is by Darling.

Resistance (Electric) Pyrometers.

When a fine platinum wire is heated, its resistance to the passage of an electric current increases progressively with the temperature. Siemens wound a coil of platinum wire on a porcelain rod, and enclosed the whole in an iron sheath. A current of electricity was then sent round the coil, and the resistance presented was measured by a complicated device whereby acidulated water was electrolysed and the amount of such electrolysis converted into temperature degrees. Later, to measure the resistance, the differential galvanometer was used and, still later the Wheatstone bridge.

Callender & Griffiths Pyrometer.

The resistance pyrometer very largely used at the present day in England, is the Callender & Griffiths, and consists of a fine platinum wire wound on a mica frame. The platinum wire is connected by stout copper leads to the head of the pyrometer. Temperatures indicated by this pyrometer are recorded by the Callender recorder. This instrument consists of a Wheatstone bridge in which the movements of the slider along the bridge wire are automatically effected by relays worked by the current passing through the galvanometer between the bridge arms. According as the moving coil of this galvanometer is deflected in one direction or another, a relay circuit is connected through one or other of the two electro-magnets. Each magnet is fixed on a clock, the movement of which is prevented by a brake. When current passes through a magnet, this brake is lifted and the clockwork revolves. These clocks are connected by gearing with the recording pen which is pulled in one direction or another according as the separate brakes are lifted. The bridge slider moves with the pen and tends to restore the balance. The pen marks on a paper mounted on a drum, and so a record is obtained. These are, of course, many varieties of indications and recorders, the above being simply one type.

About 900 degrees C. is the limit at which these pyrometers may be used continuously, but occasional readings up to 1200 degrees C. may be taken. The reason for this is that, at high temperatures, platinum undergoes a physical change which seriously affects its resistance.

Optical Pyrometers.

As the temperature of a body increases, it radiates energy to its surroundings by means of ether waves. Below 450 degs. C., these rays are invisible, but above this temperature, an increasing proportion of light rays are omitted and the solid appears a dull red color in a dark room. As the temperature increases, the proportion of luminous rays increases and the color changes to lighter red, orange, yellow, and finally white. Howe, in 1900, published the following table:

Description	Temperature deg.C.
Lowest red visible in darkness	470
Lowest red visible in daylight	475
Dull red	550 to 625
Full cherry red	700
Light red	850
Full yellow	950 to 1000
Light yellow	1050
White	1150

All optical pyrometers are based on the determination of the intrinsic brightness of the heated substance by photometric methods. The pyrometer is standardized and calibrated against a standard light, such as a carbon filament lamp, or a lamp burning amyl acetate and giving a flame of known luminosity. Two types will now be briefly described.

"Holborn-Kurlbaum."

This type, made by Siemens, consists of a short metal tube fitted with an eye piece at one end, and near the centre of the tube, a small electric lamp with a hairpin filament is fitted so as to be in the focus of the eye piece. The lamp is lighted by a small accumulator, in series with a rheostat and milliammeter. The hot body, whose temperature is to be determined is focused by means of the object lens of the telescope. The lamp and source of heat are then viewed through the eye piece and the rheostat adjusted until the tip of the filament and the light from the hot body are of the same intensity. The milliammeter is next read, and the temperature calculated from the amount of current passing through the lamp.

"Mesuré and Nouel."

Second Type.—This pyrometer is in the form of a telescope inside which is a quartz plate (A). This is between two Nicol prisms, which serve as polariser and analyser respectively. By this arrangement, one can suppress the radiations of any part of the spectrum by simply rotating the analyser (B). If a hot body be under observation, and the instrument sighted thereon, and at the same time the analyser be rotated, then the red color first seen will gradually change to yellow, then to green and then to blue. In using this instrument, it is found, as the analyser is rotated, that at a certain stage, the color of the hot body

is of a peculiar tint, neither red nor yet blue, but a sort of transition product, being a greyish blue or greyish yellow. This is known as the "transition tint" or "sensitive tint," and, when it has been obtained, the angle of rotation of the analyser is noted and the temperature deduced from scale provided with instrument, the scale having been previously obtained by focusing the instrument on hot bodies at known temperatures. Considerable skill is needed, however, and also constant practice, before temperatures can be determined with any degree of accuracy.



PREVENTION OF INDUSTRIAL ACCIDENTS.

W. H. DOOLITTLE, safety inspector to the National Metal Trades Association, in his report says that the application of scientific principles to accident prevention has met with success. A comparison of available statistics indicated that time, energy, and thought expended in this way had been the means of greatly reducing both the cost and number of accidents.

A reduction of 29 per cent. on a division of an immense railway system, of over 60 per cent. in the mills of some of the great steel companies, and of more than 73 per cent. in proportion to the number of operatives in a large industrial plant were results that must appeal to both humanitarians and financiers. In all of these instances the results were accomplished by systematic efforts.

Essentials of Scientific Accident Prevention.

The author enumerated some of the essentials of scientific accident prevention work, as follows:

(a)—The setting aside of time for the investigation of the subject of accident prevention.

(b)—Careful and continual inspection of workshops.

(c)—Investigation of the cause of each accident and the recording and tabulating of the same.

(d)—The study of the causes of accidents which occurred in like industries, and under similar conditions elsewhere.

(e)—The installation and maintenance, wherever possible, of mechanical safeguards and safety appliances.

(f)—The education of the workman as to the dangers of his occupation, and the best means of avoiding accidents in connection with his work.

(g)—Securing the co-operation of the workmen in the efforts of the employer to promote safety and prevent accidents.

Inspection a Necessity.

Accident prevention, he observed, could not be successfully accomplished without inspection. Inspectors should be thorough in order that nothing dangerous might be overlooked. They should in all cases be made by competent and practical persons who had a technical and practical knowledge of dangerous places. Inspection should also be made by every person in the plant, particularly in the locality in which he was employed. Inspections should be frequent as conditions changed constantly. When an accident happened, the first thing to be done after caring for the injured person was to investigate the cause, in order to prevent its repetition.

The author takes issue with those persons who declared that "accidents just happened." Such a statement was not much more than an effort to evade responsibility. It was an unfounded and pernicious statement, tending to put a premium on carelessness and to promote accidents. Every accident was capable of analysis and in nearly every case the cause might be located. This should be done and a record kept for future guidance. Such statistics, carefully kept, were of great value.

Wide Experience Profitable.

Every man who had the safety of his employees at heart and every workman who desired industrial safety for himself and for his fellowmen would give attention to happenings outside of his own plant. Machine and methods were proved to be dangerous by observing their operation, and the results in different localities. The larger the field covered the more valuable would be the data gathered. Circular saws, for instance, cut, kick, and kill in the same way in every part of the world. A serious accident might not have happened in a particular shop in all of its history, but this circumstance did not constitute an excuse for neglect. No plant, no industry, no locality was immune from accidents. The most successful safety engineers profited by the experience of others.

Safeguards Help Output.

There were many dangerous features of workshops that might be made comparatively safe by means of guards. It was important that setscrews, gears, dead ends, and all other man-killing parts of machinery be covered, inclosed, or eliminated. All of this might be done without in the least cutting down the output of a factory—indeed it tended to add to the output by giving the workman a sense of security. It was not enough, however, that safety devices be installed. They must be maintained.

Someone must see to it that safeguards were kept both in order and in place and if for an exceptional job a guard must be removed, it should be immediately replaced, when the job is completed.

No workman should ever enter a dangerous occupation without giving strict attention to the dangers connected with it. He should be made to do this not only for his own protection but also for the sake of his fellow workmen, who might be injured as a result of his lack of precaution. Every employer was morally responsible for the safety of his employees just so far as he, by the exercise of his authority, might prevent their being injured. Nor was it entirely an ethical question. It was not profitable to the employer for his workmen to be injured. Aside from the humanitarian aspect of the question, in a general way physical injuries to the workman meant financial loss to the employer. Therefore, for all these reasons, ethical, humane, and economic, the employer should instruct and warn the workman of danger, and no task should ever be imposed which in its performance would endanger the life or limb of the workman.

Workmen might be warned by word of mouth, but the judicious use of signs distributed about the plant, and by literature, were most potent. Warnings must be persisted in, otherwise they are of no avail. Many workmen were naturally careless, and many others were purposefully negligent, while others again viewed with suspicion, efforts that had the appearance of altruism. Every possible effort should be made to secure co-operation in the safety movement, for progress in accident prevention beyond a certain point was utterly impossible if the opposition or indifference of the workmen held sway.

In conclusion, the author affirmed that luck as a factor in accidents was always more or less under man's control, that both good and bad luck were produced by the operation of natural forces; that these forces moved according to well-defined rules, or laws; and that men were lucky or unlucky just in proportion to their understanding of these laws and their disposition and ability to live and act in harmony with them.

mending that all street cars operating in the city, be provided with the most up-to-date and effective air-brakes. The case under consideration was the third arising from the same accident, the plaintiff, Mrs. Kazaransky, having been injured in the melee when a small type car of the St. Lawrence Street line slid down the St. Lawrence hill and crashed into another car standing at the corner of Ontario Street. The mishap occurred on November 8th last, and as a result there were eight or nine actions filed against the Montreal Tramways Co. According to the jurors who disposed of the present case, the Tramways Company, must not "permit" collisions. For, the mere act of "permitting" such untoward occurrences, constitutes fault, according to the view of the latest panel. It is interesting to note the divergence of opinion of various jurors, called upon to deal with the cause of this self same accident. In the first case arising, the jurors to a man, in giving a verdict in favor of the plaintiff, held that the company was at fault because the motorman of the smaller car had seen fit to attempt to descend the hill before the car at the corner of Ontario and St. Lawrence Street, had left that point. In the second case, the jurors, also finding in favor of plaintiff, held that the company was to blame, because the motorman of the smaller car did not have his conveyance under proper control. The jurors, in this instance, indulged in generalizing, and went a step further, holding that the company was to blame because it had "permitted" the accident. It is understood that at least one of the remaining cases to be dealt with, will come up before a judge for resolution, and, hence, it will be interesting to ascertain what views the Bench express regarding the cause of the mishap. The award in the case of Mrs. Rosansky, was \$729, the jurors rejecting a claim put forth, to cover an operation, which according to medical testimony adduced, may be necessary in the future, as a result of the injuries by the victim. There was some doubt as to the exact nature of Mrs. Rosansky's injuries. It was shown that she had been shaken up in the collision, and had been confined to her home for a few weeks. The injury received manifested itself in a condition of dizziness and nervousness from which the plaintiff claimed she suffered as a direct consequence of the accident. Expert witnesses called on either side, expressed divergent views as to the nature of the malady, those for the plaintiff averring that she had probably sustained a concussion of the brain, and that probably she would have to undergo an operation. Peter Bereovitch, K.C., with Ernest Pelissier, K.C., appeared for plaintiff, while Perron, Tashereau Co. acted for defendant.

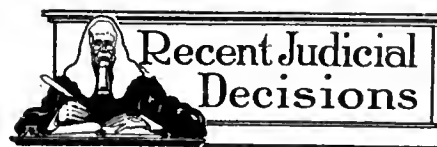

Montreal.—A jury empanelled to deal with an accident claim arising from a street car collision, in reaching a verdict in favor of plaintiff recently, added a rider to their finding, strongly recom-

Helping Young Men to Find Their Particular Vocation*

By Herman Schneider

It is generally admitted that a large percentage of the men engaged in trades and professions are to a lesser or greater extent operating in a department for which they are ill-adapted. This paper deals with the question, and enumerates and classifies prominent characteristics of temperament which have come under the author's notice, during several years practical experience in the art of vocational guidance.

SEVERAL years ago, two young men appeared at my office to apply for admission to the co-operative course. Although they came together, they were not mutually acquainted, one being from Kansas and the other from Ohio. They were of the same physical build; they had the same facial characteristics; their scholarship records were equally good, and both said they felt an impulse toward mechanical engineering. Both looked like good material. The conversation disclosed no radical or even slight differences in their personalities. They gave promise of being a good "pair," and consequently were sent to the same machine shop.

The Parting of the Ways.

In due process of events, a co-ordinator from the engineering college called at the machine shop. The foreman said Kansas was satisfactory, but Ohio didn't get into the work. Each time the co-ordinator called, the foreman reported Kansas as most satisfactory and Ohio as more and more unsatisfactory. In a month Kansas was turning out his work with the ease, sureness and dexterity of an old hand, while Ohio was getting a case of nerves, spoiling work and developing fatigue. The superintendent asked us to try Ohio elsewhere, but we decided for a number of reasons to continue him in the shop a little longer.

In the university, however, Kansas was soon reported to my office as utterly hopeless. His scholastic grades were almost zero in all his subjects. He gave no reactions at all in class and laboratory work. His teachers said he was stupid, while Ohio came to his school work with avidity. He was mentally keen and seemed to delight in his work.

Kansas grew nervous over his school work, but Ohio thrived on it. Kansas at school was tired out at 10.30 each morning; Ohio got better as the hours went by. Kansas longed for the rest which shop work gave him; Ohio longed for the rest which school work gave him.

Careful tests and conference showed conclusively that Kansas broke under mental work, mental responsibility and self-directed and diversified manual work; but that he expanded in spirit,

health and satisfaction under repetitive shop processes which were planned for him. Similar tests and conferences showed that Ohio broke under the strain of directed repetitive processes, and to a lesser degree under self-directed and diversified manual work; but that he thrived when given mental problems and responsibility.

We have lost track of Kansas, but Ohio is happy and successful in commercial life.

Calling Determined by Elimination.

There comes to mind another young man, who called one morning and presented a splendid scholarship record from a rigorous high school. He was a most attractive youngster — sturdy, clear-eyed and cheerful; but he had not the faintest idea what he wanted to do for a life work. The whole world looked good to him, but no lead I made could discover any particular bent. He smilingly offered to try anything, and finally offered to try everything we had so as to arrive at something by process of elimination.

We started him at foundry work. He didn't like it, so he went cheerfully from one type of work to another for two years, always working hard and faithfully, but without satisfaction, either to himself or to his employers. His school work was excellent except in technical courses. All this time we were taking account of his talents. Certain characteristics began to stand out, and one day the question was put to him bluntly: "Blank, how would you like to be a librarian?" His response might possibly be called a grateful unanimous yell. So he is now making progress in a library school.

Varieties of Temperament.

Cases similar in kind, but highly dissimilar in detail to those cited, could be given by the dozen. We have found, for example, that some young men cannot grow in all their parts in indoor work and others like it and thrive on it; some must have roving work (such as the railroads furnish), while others are upset by it, and are happy only in a settled job; some like to fuss over a little piece of intricate mechanism, while others like a hurly-burly task of big dimensions; some chafe under accurate directions, which eliminate personal in-

itiative, while others produce cheerfully under them; some evade responsibility, while others assume it naturally.

Now a man is most efficient when his work gives him the greatest satisfaction; when he is doing the thing his Creator intended he should do. Every working man, from the hewer of wood and drawer of water to the research scientist, should get three things out of his work: First, mental and physical development and discipline; second, joy in doing it (or at least satisfaction); and third, a decent living. The man who has found the job that his soul is blindly craving, the job for which he has inborn talents, gets these; but the man whose whole being revolts at his task, becomes a captious citizen, an inefficient worker and a meagre earner.

Work Classification.

Under present conditions, our youth blunder into jobs; the gambling odds against their finding work suited to their temperaments and talents are too high, for there are many types of work, and usually but one general type will fit any single individual. There is no method or agency to determine the general type of work for which a youth is talented, and which classifies the various jobs which fall under this type.

Unfortunately, work has been classified heretofore by the materials used or produced, rather than by the characteristics necessary for success in it. Thus, if a boy were successful in woodshop work, he was told he would make a good carpenter; however, wood turning in a shop and outdoor carpentry are dissimilar types, while wood turning in a shop and metal turning in a shop are similar types. The fact that work is becoming more sub-divided and more intensified makes the situation more acute, and the problem becomes a national one. A nation, especially a self-governing nation, many of whose self-governors do not get the three returns mentioned out of their work, is not a stable nation.

Work and Workmen Characteristics.

Every individual has certain broad characteristics and every type of work requires certain broad characteristics. The problem then is to state the broad characteristics, to devise a rational method to discover these characteristics

*Abstract of a paper read recently before an Association of Constructors by the Dean of the College of Engineering, University of Cincinnati

(or talents) in individuals; to classify the types of jobs by the talents they require, and to guide the youth with certain talents into the type of job which requires those talents. This is a big problem, but one possible of measurable solution, or, at worst, possible of a solution immeasurably superior to our present haphazard methods.

University Co-operative Work.

In seven years of co-operative work at the University of Cincinnati, we have had experience with about 500 co-operative students. As with the young men, Ohio and Kansas, so with other students, marked characteristics in time stand out. These we have classified, and they now constitute a sort of guide to us in helping students to find themselves. The list is by no means considered as final; future experience will of course modify it, but it does furnish a rational basis of broad selection. It is realized also that our work is principally in co-operation with manufacture, construction and transportation; and other broad characteristics would probably be listed if we had similar relations with commerce, law, medicine and religion. Since the object of this paper is to point out what appears to us as a rational beginning of vocational guidance, criticism of the characteristics given is looked for in hope rather than in fear.

Physical Strength and Physical Weakness.

(a)—In many occupations, physical strength is an essential; for example, in draying, stone-masonry and baggage handling. In others it is not; for example, in bookkeeping, telephone installing and piano tuning. Mankind ranges from the almost helpless cripple to the physical giant. We, therefore, have the two characteristics—physical strength and physical weakness.

Mental and Manual Feature.

(b)—I have in mind a number of our students who were utter failures at all kinds of work requiring manual dexterity, but who maintained uniformly good grades in all their school work. Their efficiency was all head efficiency. There have been a number also who were hopeless in all their university work, but whose hands acquired skill easily. Their efficiency was all hand efficiency. The first type might make good designers, inspectors, executives or writers, but unlike the second type would drag out hopeless existences as machinists, molders, masons or piano makers. Of course, most of our students possess both efficiencies. Our experience has taught us that some men are mental and some are manual, while some are both.

Settled and Roving Temperaments.

(c)—There is a type of man who wants to get on the same car every morning, get off at the same corner, go to the same shop, ring up at the same clock, stow his lunch in the same locker, go to the same machine and do the same class of work day after day. Another type of man would go crazy under this routine; he wants to move about, meet new people, see and do new things. The first is settled; the second is roving. The first might make a good man for a shop manufacturing a standard product; the second might make a good railroad man or a good outdoor carpenter. Recently two of my students were not doing well; both were getting into a condition of unrest. One was in a railroad shop. He complained that every job was different from every other job, that he was sent here and there, that there was no continuity to the work, and that he was getting nervous. The other complained that there was not enough variety to his work that it was too confining, that he could not move about and do new things all the time, and that he was getting nervous. We gave each the other's place and both are swinging along and learning most satisfactorily.

Indoor and Outdoor Characteristics.

(d)—There are two broad characteristics which are easily discoverable even in first interviews, the indoor and the outdoor. When a blizzard is raging, the first type likes to hear the roar of the wind because it heightens his sense of protection indoors and emphasizes the coziness of his fireplace, while the other wants to go out and fight his way against the storm. When the rigors of outdoor railroad and construction work are vividly pictured to these two types of young men, one's eyes will light up and his muscles will get tense; the other will compact himself as if for shelter.

Responsibility Feature.

(e)—We have found two characteristics which are quickly brought out in practical work, but which are not so easily discernible in school work. Some young men naturally assume responsibility; others just as naturally evade it. It is a well known fact to all superintendents that the most productive workmen often make inefficient foremen, while an inferior producer often makes a good foreman. One man is directive, the other is dependent. A drayman for a large jobbing house was promoted to foreman of drays, at a substantial increase in salary, because he was intelligent, honest, sober, accurate in his deliveries, careful to a marked degree of his team and dray, and loyal to his employers. In his new position he worried and grew fretful; in time he began to fail physically; finally he asked for his

old job, happiness and efficiency, just about the time his employers had decided that he was incompetent as a foreman.

Originality—Directiveness.

(f)—There are two characteristics which are sometimes confused with those just stated, but which are essentially distinct. For example, we had two students in a large shop working in the planning department; one was fertile in suggestions, but the other usually put them into effect. The first was original; the second was directive. The man who is original may make a good designer, but unless he were also directive he would make a poor superintendent; he might be a good window dresser, but not a department store manager; a writer, but not a manufacturer; a reformer, but not a mayor. A partnership in which one man is directive and another original is usually successful. Of course, one person may possess both characteristics.

Then there is the man who does only what he is told to do, and exactly as he is told to do it. He is imitative. He would dress every window like every other window. He might make a successful milk wagon driver, since he would have a fixed route and a bottle of uniform size to deliver; but he would probably make an indifferent drayman, since he would not have a fixed route, and originality (or ingenuity) would be needed to load and unload unwieldy boxes and barrels under adverse conditions. He might make a good machine molder, but not a good floor molder; he would probably be successful and happy at a punch press, but not in a toolroom.

Scope Feature.

(g)—Then there are the two types mentioned before, one of which likes to fuss with an intricate bit of mechanism, while the other wants the task of big dimensions—the watchmaker, the engraver, the inlayer, the painter of miniatures on the one hand; the bridge builder, the steel mill worker, the train dispatcher, the circus man on the other. One has small scope, the other large scope.

Adaptation Characteristic.

(h)—Some men can easily adapt themselves to any environment, while others act the same under almost any circumstances. One takes the local color like a chameleon, the other is always the same monochrome. One is adaptable, the other self-centred; one a salesman, the other a statistician.

Thinking and Doing—Doing, Then Thinking.

(i)—There is a distinct type which thinks and then does, in contrast to

which there is the type which does and then thinks. One is deliberate, the other impulsive. The northern races are usually deliberate, the southern impulsive; one controls its passions, the other is frequently controlled by them. An army of cool-headed officers and hot-headed soldiers is a highly effective machine, but in the civilian walks of life the impulsive characteristic is negative; that is to say, there seems to be no occupation in which it is a requisite. There are many vocations, however, in which a man must be deliberate.

Other Distinctive Features.

(l)—We learn quickly that some men have manual accuracy and others manual inaccuracy. Where manual inaccuracy is inherent, it is well-nigh impossible to correct it; but where accuracy is inherent and the man is inaccurate through habit, the defect can be remedied.

(m)—Similarly we have the two elements—mental accuracy and mental inaccuracy. The former has much the same meaning as the word logical, and the latter as the word illogical.

(n)—Certain men are concentrative mentally; they bring all the light they possess to focus on the subject under consideration; they are mentally centripetal. On the other hand, we find men who are mentally centrifugal and who wander from the subject under consideration or flit from one subject to another; they are diffuse.

(o)—Some men go to pieces in an emergency; whereas if they were given time to consider the situation they would hold together and act wisely. They possess slow mental co-ordination. The emergency man must possess rapid mental co-ordination. The latter is necessary for success in the baseball player, the locomotive engineer, the motor-man, the surgeon. The former is usually typical of the philosopher, the jurist, the research scientist.

The Grit Feature.

(p)—One often hears it said of a man that he has no push, or that he lacks determination, backbone, grit, sand; other men are said to possess these qualities. The first we call static, which means to cause to stand still, and the second dynamic, which means to cause to move. It should be noted that the noisy man is not always a dynamic man—on the contrary, he is frequently static; while the quiet man is very frequently dynamic.

Danger of Hasty Judgment.

Experience has warned us against the danger of hasty judgment; for we have found strong characteristics buried deep under the influence of environment—innate controlling talents held repressed

or stunted by acquired habits of life; and sometimes the habit is mistaken for the talent until patient experimenting or some unusual occurrence discovers the hidden ability. Let it be noted at once that while the characteristics are placed in juxtaposition, it does not follow that one may not be, for example, both mental and manual, or both an indoor and an outdoor man; further, one may not possess either characteristic to any marked degree. It should be noted also that certain moral qualities, such as bravery and honesty, are not given on this list. While these are, of course, very important characteristics, and while certain jobs require them to a high degree, we have felt that the ethical qualities are not essential for the purposes for which this list was devised.

Organization Sense.

It is again desired to emphasize the fact that this is an empirical list, growing out of the observations of about 500 young men in industrial work and university work connected with the engineering profession. It is probably too restricted, and may not contain characteristics which are fundamental. For example, we believe that there is another element which is not given, and which is not a result of combinations of the elements given. The words "organization sense" have been suggested for it. The idea to be conveyed is something like that of the word "tidy," the natural tendency to keep things in proper and becoming neatness. This characteristic is evidenced in the way men keep their desks, the way they write their reports, and in the general orderliness of affairs within their jurisdiction.

Personal Pride and Material Gain.

Again, we find among our students two distinct types, one of which does a thing more for the personal satisfaction of doing it than for the immediate or prospective material gain, while the other places the material gain first. One plays the game for the game's sake; the other plays it as a means to a tangible prize. I know a doctor who sacrificed \$10,000 a year to be a research scientist; he is a vocational idealist. I know also a research scientist who gave up a brilliant career to acquire \$5,000 more a year; he is a vocational materialist.

The type of craftsman to whom pride in his product means more than time or money, and whose soul goes out through his fingers into the thing he makes, is of the first type; the other type makes the thing to sell at the largest profit. It is probable that most men have these two characteristics in about equal measure; that is to say, while they have pride in

their product, they do not let this outweigh the commercial necessities. The sincere reformer is a type of the vocational idealist; the practical politician of the vocational materialist.

To the idealist, the doing of the thing as well as he can possibly do it is the end; to the materialist, the doing of it in such a way as to get the most material return is the end. In extreme cases the vocational idealist will suffer all kinds of privations, and let his family suffer too, rather than be less thorough and better fed. On the other extreme, the vocational materialist will drop any idea that does not pay and take up any that does.

Major Characteristics.

In the fore part of this paper, three things were mentioned as necessary results of work; two of them were joy in the doing of it or mental satisfaction, and a good living or physical satisfaction. When mental satisfaction dominates a man's work, he is idealistic; when physical satisfaction predominates, he is materialistic. These should probably be placed in the table of major characteristics.

The psychologist may object that these characteristics are not basic, that they are complex, in that they are made up of simpler elements. This is true, but the same objection could be urged by the chemist against the engineer's use of the words water, air, wrought iron, steel, brass, wood, granite and cement. Just as the hydraulic engineer uses water, so does the shop manager use mental accuracy or originality; neither is concerned with the more refined science of the basic elements of which the substance or the characteristic is composed.

Of course, the degree or strength of human characteristics can never be measured as can the strength of material things. The mind of even the lowliest man is too subtle a thing to be catalogued, hence the limitations of vocational guidance. I am of the opinion that for the present vocational guidance can only point out in which types of occupations an individual will in all probability not be successful.

The Point of View.

It will be contended, too, that a characteristic, as for example, originality, has different meanings to the artist, the shop man and the department store manager; that it depends upon the point of view. So it does, just as the quality of wood means a different thing to the papermaker, the bridge builder and the furniture maker; but to each in his own field, the meaning approaches a fairly well defined standard.

It must be borne in mind that the results given here have been obtained from young men, whose average age is about 20 years, and how many of these characteristics are determinable in children from 13 to 16 years old I am not prepared to say, since I have had no experience with boys of this age.

While the classification given has been found empirically, the working of the principle of evolution is at once evident. Every distinct people possesses certain characteristics, the result of the thousands and thousands of years of conditions peculiar to it. Thus the Chinese are settled, the Arabs are roving, the Sicilians are impulsive, the Hindoos are deliberate, the Japanese are manually accurate, the Persians possess a refined color sense. If a nation has been a roving nation for several thousand years, and then a settled nation for several thousand years, some of its present-day representatives will be roving and some settled.

Any individual's characteristics are probably atavistic. If all the age-long impresses of the past were equally transmitted, all brothers would be alike. When an individual does not possess certain characteristics which he might be expected to possess, it is a case of arrested development of these characteristics in that individual. They are probably latent but inhibited, and will appear in his descendants.



EQUIPMENT OF LAUNDRIES.

THERE is perhaps no modern industry which has made such rapid advances in a comparatively short period as that of the steam laundry. The first attempt, in England, to establish a laundry with power-driven machinery appears to have been made about the year 1863, but the equipment employed at that period was of rather a crude description and would compare very unfavorably with the appliances in use at the present time. It was really about the year 1892 that the commercial possibilities of the steam laundry began to be realized, and the increase in its numbers has since been very marked. At the present time there is hardly a town of any size with a good resident population, in which a steam laundry is not to be found. In addition, there are a great many well-equipped steam laundries attached to factories which produce various classes of goods where the use of a washing, drying, and calendering plant is a feature.

The Plant Employed.

The motive power is usually obtained from a steam engine with a boiler of sufficient power to provide steam not

only for the engine, but for all the machines and appliances. Within recent years, however, electricity has been adopted in a great many laundries. In favor of a steam engine, it may be urged that it enables considerable economies to be effected, by utilizing the exhaust steam, which would otherwise go to waste, for heating water or a drying chamber. The electric drive, on the other hand, possesses many advantages, chief among them being that the machines can be driven independently by direct-coupled motors, without the need of running the whole length of shafting to accommodate one or two of them. In this way there is less waste of power.

The washhouse equipment usually includes a rotary washing machine, a hydro-extractor or centrifugal, a soap and soda boiling tank, a starcher, hand wash tubs, rinsing and steeping tanks, and power wringers.

The Washing Machine.

The washing machine is one of the most important parts of the whole plant, for the reason that if the goods are not properly washed, the succeeding processes cannot be carried out with satisfactory results, no matter how carefully the work is done. A washing machine is usually made entirely of metal and consists of a forced outer casing of galvanized steel plate and a revolving inner cylinder of brass, in which are placed the goods that have to be washed. The inner or washing compartment is perforated with circular holes and fitted with brass rubbers or beaters which form the principal washing element. A door with suitable locks is provided on the shell to prevent the goods from falling out during the washing process.

The shell is driven by gearing at one end, a reversing motion being provided so that the cylinder makes $2\frac{1}{2}$ revolutions in one direction and a similar number of revolutions in the opposite direction. Hot and cold water and steam are led into the washing compartment with soap and soda solution, and the goods are allowed to splash about during the revolutions of the shell. As the shell revolves, the washing solution is lifted by the hollow brass rubbers and dashed upon the load of goods, so that a continual showering process is set up.

The Hydro-Extractor.

When the goods have been well washed and rinsed they are taken out of the washing machine through the doors and conveyed to the hydro-extractor. This machine consists of a perforated steel basket revolving at a high speed on a steel spindle, with a fixed outer casing of steel boiler plate. Its function is to expel all the loose water from the clothes by centrifugal force, and eject it through

the perforations in the steel basket; this water being drained away. The machine will extract the water from a load of goods in from 10 to 15 minutes, and they are then ready for the next department—the drying chamber.

The Drying Chamber.

There are several forms of drying chamber, but perhaps the most popular is a range of pull-out drying-horses. These horses consist of cast-iron frames with front and back plates, fitted with steel rails on which the goods are hung. Each horse runs on rails set in the concrete floor and can be readily pulled out for loading purposes. When the goods have been hung up on the rails, the horse is pushed back into the chamber, which is heated to a temperature of 150 deg. F., either by steam radiating coils placed in a pit underneath or by a hot-air apparatus fixed on the roof overhead.

The system of double compartment or twin drying chambers is also very popular, the fittings in this case being steel hanging rails fixed at the top of each chamber, the hot-air system being adopted as in the drying horses. A cooling installation is provided so that while a load of goods is being dried in one of the chambers, the other is being cooled to permit of the operator entering and unloading in a more comfortable atmosphere; the same process being repeated in turn with the second compartment.

Ironing and Finishing.

The next and final process is the ironing and finishing, for which a large variety of machines can be used. The most popular machine in laundries of average size is the single roller or Decoudun type. This machine consists of a large steam-heated padded roller which revolves in a steam-heated bed of semi-circular form, the goods passing between the bed and roller. The single roller machine is usually employed on starched goods where a high finish is required, such as table cloths, table napkins, etc. In another popular form of calendering machine, there are multiple rollers, varying in number from two up to eight. The principle of this machine is the same as that of the Decoudun type; the goods being again passed between the rollers and the steam-heated beds, but in the multiple machines, especially those of the larger size, they are dried, ironed, and finished in the machine instead of being first hung up in the drying chamber. In this way a considerable saving in labor is effected; hence the popularity of the multiple roller calendering machine in the larger laundries that undertake a high percentage of flat work.

Collar and Cuff Ironing Machine.

The collar and cuff-ironing machine is a most interesting mechanical contri-

vance. The collars are laid on a flat board that passes backwards and forwards under a polished gas-heated roller, by which the necessary finish is imparted. A skilful operator can finish about 300 collars an hour. Other machines employed in the calendering department include power goffering machines for frills and fancy work, neckbanders for ironing the neckbands of shirts, shaping machines for rounding off collars, and hand gas or electric irons.

Steamship Laundries.

Within recent years, steam laundries have been introduced on many ocean liners making long voyages. They have also been fitted on a number of warships and private steam yachts. The laundry is usually situated at the stern of the ship and occupies an area of about 12 by 10 feet. Into this limited space are introduced one or two washing machines, a hydro-extractor, one or two hand wash tubs, a small steam-heated drying chamber, and a calendering machine and electric irons. The prime mover is an electric motor driving a countershaft, which transmits the necessary power to the machinery. The hydro extractor and calendering machine are driven by direct-coupled motors, so that either of them can be used without running the others, as would be necessary if a line of shafting were employed. In any case, line shaft drives are always objectionable on a ship on account of the accompanying noise and vibration. The hand-irons used for ladies' blouses, gentlemen's dress shirt fronts and cuffs are heated by electricity, the current for them and for the motors throughout the laundry being obtained from the ship's generating plant.

As can easily be imagined, economy in the consumption of fresh water in the ship laundry is most essential, and for this reason the rinsing water taken from the washing machine is used again for the following wash with soap—i.e., instead of being allowed to go to waste, it is pumped into an overhead tank and thence to the washing machine.

Private House Laundries.

Steam power laundries are to be found in many private houses. The laundry is usually a detached building at some little distance from the house, and is equipped with washing machine, hydro extractor, drying chamber, calendering machine, etc. The walls are usually covered with white tiles and the floor with smooth concrete. Where electricity is not available, and a steam engine is regarded as objectionable, a petrol motor is often employed as the source of the necessary power. In some cases manual power is relied on, the appliances then being made small and light, to permit of their being operated by hand.—T. E. S.

SELF-EQUALIZING EXPANSION JOINT.

THE Badger self-equalizing expansion joint is a corrugated copper joint, having external rings. It is designed to take up changes in length in pipe lines, whether these pipe lines convey steam, water, or air. Probably every engineer has had experience with the irresistible strains in pipe lines caused by expansion and contraction. Loose, leaky fittings, and, perhaps, here and there a fractured joint, point conclusively to the necessity for some device having sufficient flexibility to absorb these changes in length. The engineer also knows that the amount of change in pipe length depends upon two factors—the length of the pipe and the difference in temperature. Although old-fashioned bends and long sweeps and loops are useful in making changes in direction, and have been used quite extensively for taking care of changes in length, they are not beautiful and they take up much valuable space; cracks, also, are liable to develop under repeated temperature changes. The slip joint has the one disadvantage of requiring frequent packing.

The Badger joint combines the elasticity to stand repeated changes of shape, with strength to resist any pressure for which the joint is designed. The well-known corrugated form, such as used for furnaces of internally fired marine boilers, is adopted because of its strength and flexibility; but a single piece of copper would have to be very thick for high pressures, and in actual practice it is found that there is always a tendency for one or two corrugations to take the entire strain of repeated change in shape. In time those few corrugations, by taking all the work, give out.

External rings on the corrugations of the Badger joint distribute the strains among several corrugations, and by thus bringing many corrugations into service no one of them is called upon to take more than its share of the work. The external rings force a part of the strain to the next corrugation, and as each corrugation has but slight movement, the joint lasts almost indefinitely. The external rings give added strength to the joint in the same way that spiral winding of a pipe with wire adds to its strength.

The number of corrugations depends upon the pressure and upon the length of the joint. For high pressures and superheated steam the change in length is considerable; therefore, more corrugations are used. For very low pressures, as in exhaust piping, two or three corrugations are sufficient for the slight alterations in length. There are even some cases where the expansion

is so little, although vibration must be taken up, that the joint does not need any external rings. In most cases, however, external rings are used both to add strength for high pressure, and also to stiffen the exhaust pipe against collapse.

The Badger Expansion Joint, manufacturers, the E. B. Badger & Sons Co., Boston, is made in a complete line of sizes for all pressures and with flanges drilled to A. S. M. E. standards, both high pressure and extra heavy pressure. The joints require no packing and take up no more room than a pipe fitting. For low pressure work, they have been made up to 6 feet in diameter, and have been made oval, rectangular, circular, and in special forms.



New Incorporations

Window Strip and Supply Co., Ltd., incorporated at Ottawa, capital \$50,000, to manufacture metal weather strips, etc., at Montreal. Incorporators: Harry W. Ellicott, Harry Cutmore, etc., of Montreal.

Calgary Brick and Supply Co., Ltd., incorporated, and with offices at Toronto, capital \$200,000, to manufacture bricks, etc. Incorporators—William Laidlaw, Clifton Medley, etc., of Toronto.

Oxygenated Stove and Heater Co., Ltd., incorporated at Toronto, capital \$350,000, to manufacture and sell stoves, etc., in Toronto. Incorporators—Jay B. Burdick, Albert W. Craig, of Toronto, etc.

D. J. Barker Foundry Co., Ltd., incorporated at Toronto, capital \$100,000, to manufacture and sell stoves, furnaces, etc., at Brighton, Ont. Incorporators—William W. Porte, Samuel Ross, of Brighton, etc.

Galeta Silver Mines, Ltd., incorporated at Toronto, capital \$500,000, to acquire, own, lease, etc., mines and mineral lands; headquarters at Toronto. Incorporators—Albert D. McMillan, of Winnipeg; Charles Maclean, of New York; etc.

Ontario Steel Products Co., Ltd., incorporated at Ottawa, capital \$20,000,000, to manufacture iron, steel, and all other metals, and all or any articles consisting or partly consisting of iron, steel, or other metals and all or any products thereof, also coke and cement; to erect and maintain all suitable furnaces, mills, factories, engines, houses, structures and buildings, at Ojibway. Incorporators: Peers Davidson, George A. Childs, etc., of Montreal.

MACHINE SHOP METHODS ^A_N^D DEVICES

Unique Ways of Doing Things in the Machine Shop. Readers' Opinions Concerning Shop Practice. Data for Machinists. Contributions paid for.

TWO AIDS TO VISE WORK IN THE MILLER.

By R. D. P.

IN one plant, we made considerable use of cold rolled steel—the "C.R.S." of the drawings, and kept twenty to thirty tons constantly in stock, mostly flats. The demand for the products into which the steel was worked, however, would often stray from standard sizes, and, as might be expected, was often required in too much of a hurry or in too small lots to secure the material rolled to size. For instance, a requisition would call for two hundred feet of 1/8 in. x .984 in., and a

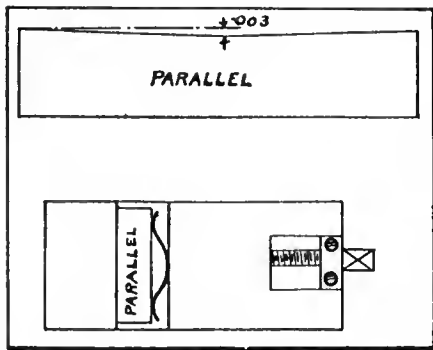

FIGS. 1 AND 2. AIDS TO VISE WORK IN THE MILLER.

month later, another requisition would call for something that took a thousand feet of 1-16 in. x .504 in. The thickness always remained standard, and our work was to cut the necessary amount from the edge of the next size larger. In doing this, we employed two methods, that selected being dependent on the character of the subsequent machining operations.

One method was to shear the strips off in lengths of 4 in. to 8 in., as might be required to fit the jigs, and to place a "bunch" of them in the miller vise and pass a high speed cutter over them. A weak point, however, presented itself, and for a time completely puzzled us. Six pieces of, say, 1-16 in. x 9-16 in. x 6 in. steel would be put in the vise, hammered down on a parallel (vise and parallel of tested accuracy), and a cut taken over them. On measuring the work, the ends were found to be just alike and right, but the centre would run .002 in. or .004 in. low. We used a piece of flat stock between the hammer and the work so that the latter would not be battered up, and cause one piece to pull away from its fellows. We used the "drop" of a heavy hammer to reduce rebound to a minimum. The only conclusion that we could reach was that the

low centre came from the spring which always takes place when cold rolled steel is cut; that this spring was even stronger than the grip of the vise, and that as the stock was removed, the pieces bent upwards in the middle (very slightly of course), and caused the cutter to take a deeper cut. To overcome the difficulty, we evolved the "unparallel parallel," as the boys called it. This was an ordinary parallel carefully drawfiled low in the centre, and micrometered gradually lower from each end to .003 in. or .004 in. deep in the middle. When the work was hammered down on this, we beat the steel at its own game, putting in an initial bend, which, when cut across came out to within our limits of accuracy. Fig. 1 shows the parallel.

Chips from a miller are small and exceedingly numerous, and just one of them under a piece of work will spoil its accuracy. A great deal of time and care must, therefore, be spent in keeping a miller vise clean each time when loading. The use of a parallel under the work gives an extra surface to clean and the presence of oil adds to the situation. Chips cannot accumulate under a piece that is not moved, and in the work mentioned above, we fixed our parallels by means of a low spring between the parallel and the moveable jaw. This spring kept the parallel to its seat, yet when we wished to move or change it, no screw need be moved. Much time was saved by this kink. Fig. 2.



THE USE OF FITTING NUTS.

By D. A. H.

WHEN we have much fitting and seraping on a split box, we use special fitting nuts to save time in screwing on and off. A pair of these

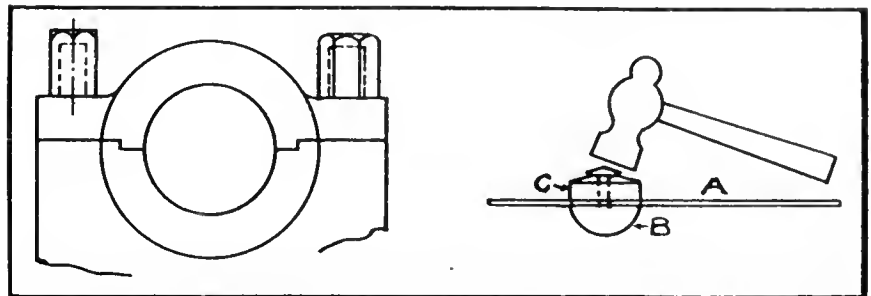

FITTING NUTS.

RIVETING HINT.

are shown in the drawing. In this case the studs are long enough for double nuts, which are often required, and to

screw two or four nuts down this length takes a long time. Hence the special nuts which are made of hexagon steel, drilled out body size for two-thirds of their length and case-hardened. The time saved in seraping one cap will pay for their cost. An added advantage is that the nuts to be ultimately used are not marred up. In lieu of these nuts a section of tubing or pipe could be used under a standard nut.



HINT FOR RIVETING.

By Donald A. Hampson.

A THOUSAND studs, or buttons (B), were to be riveted to the disc (A). The countersink washer (C) was placed on the back, and the stud riveted in and over it as shown. Having provided a suitable riveting block with hardened recess for the round head, the next thing to do was to simplify the movements of the operation, so as to do the work best and in the shortest time. Ordinarily a man would hold the disc down against the block with one hand, and, with the hammer in his other hand, would go around and around the stem, delivering blows to form the conical head, changing the position of his hand at each blow, so that his hammer face was always flat with the face of the cone. Not so in this case. The man was instructed to keep his hammer always in one place and at one angle, which was easy to acquire and easy to maintain hour after hour. With the left hand the disc was fed around, the button forming a central pivot, and making this also easy, while the fingers could turn the disc without tiring. A moment's consideration will commend this to be what we found it—a good move.

The rivet heads were made uniform and tight in a minimum of time and without skilled labor.

DRILLING FAN SPINDLE BLADES.

By H. R.

THERE is described and illustrated herewith a simple and rapid method of drilling rivet holes in the blades of fans, such as are used on automobiles, the zinc fins being thereafter riveted in place. The details consist of a casting (A) into which the pivot pin (B) is screwed at such an angle as to bring the one blade to be drilled horizontal with the bush plate (C), which swings on the hinge pin (D) and carries the drill bushings (E). On the pivot pin (B) the fan centre revolves.

To operate the jig, a casting is slipped onto the pivot pin (B), the plate (C) being then swung into position, and

oil, Board, of Trade, and railway and steamship companies, there was discussed the absolute need of more accommodation for steamers next winter. Superintendent Downie declaring that the traffic at West St. John would double within the next five years.

Urgent representations have been made to Ottawa, and, as a result, tenders have been called for the construction of an additional wharf. Another wharf is now under construction, and it is hoped to have it finished before winter. Very strong pressure is being brought to bear upon the contractor to hurry the work. It will also be necessary to provide two of the existing berths with grain conveyors, and make some other improvements, in order to be ready to handle

not likely that the line will be built this year. The proposed line leaves the Toronto-Sudbury line at mileage 170 north of Toronto, and runs northeasterly through the villages of Whitestone, Golden Valley, Restoule and Nipissing to a junction with the company's transcontinental line near Callendar. The standard of curvature will be six degrees, although there will be one or two which will be temporarily sharper. The line will cross the Whitestone, Maganatawan, Pickerel, Comanda Creek and Wisti-wasing streams.

The Maganatawan and South Rivers are the only crossings of any moment—the former comprising a deck span of 100 feet, and some 300 feet of trestle approach, 45 feet above the water; and the latter 300 feet long and 25 feet high. There is a very large quantity of timber to be brought out from the townships of Mackenzie, Mills and Patterson, the estimate being from 350 to 400 million feet, 100 million feet of which is pine.

Aside from running through this area of timber, the line traverses for over half the distance a very fair agricultural country, which has been settled since the early days of the lumber industry.

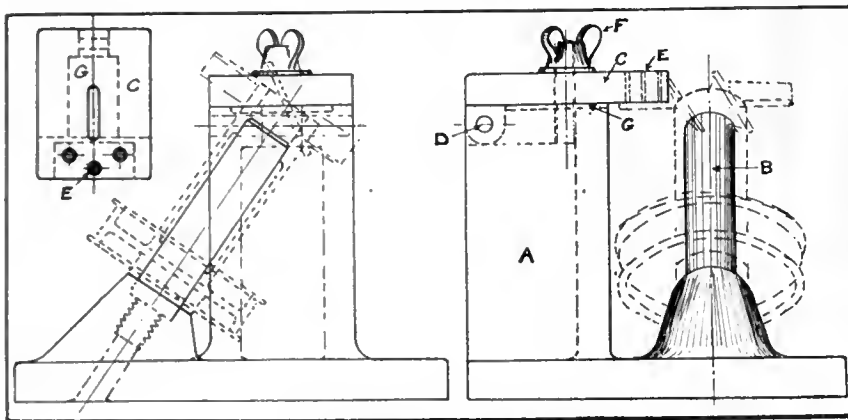

DRILLING FAN SPINDLE BLADES.

held securely by the wing nut and washer (F). From the sketch it will be clearly seen that it is impossible for the component to move when the plate (C) is screwed in place. After one blade has been drilled the wing nut is unscrewed in order that the swing plate may be removed, and the next blade to be drilled put in position, and so on, until the blades are all completed. The plate is located by the slot and key (G).

ST. JOHN'S PORT FACILITIES.

SO rapid has been the growth of winter steamship traffic at St. John that Superintendent Downie, of the Atlantic Division of the Canadian Pacific Railway Co., declared at a public meeting recently that in the matter of providing facilities for handling traffic the port was five years behind. The greatest increase in business has been in import traffic. This has more than doubled in the last five years. There has also, however, been a steady and rapid increase in export business, resulting in a yearly increase in the number of steamship sailings, and in the demand for accommodation at the wharves at West St. John.

At a public meeting, which was attended by representatives of the City Com-

next winter's business in a satisfactory way.

While attention has been directed to the development of the harbor at East St. John, and the construction of the great breakwater, dry dock and other harbor works there, the traffic at West St. John has completely outgrown the facilities, and made it necessary now to put forth hereulean efforts to catch up with the demand for more wharves and warehouses. The new C.P.R. elevator will be completed this year; and there will be much more grain as well as other cargo to be handled next winter. Up to the end of April, the value of exports by the winter steamships was greater than that for the whole season of 1911-12, and here were still a large number of cargoes to go forward.

TORONTO-OTTAWA LINE.

THE last section of the Toronto-Ottawa line of the C.P.R. to be completed is that between the Jack River and Smiths Falls. The ballasting and final completion of the line will take several months. It is officially announced by the C.P.R. that the company has a route surveyed for a line from north of Parry Sound to Callendar, Ont., but it is

COAL PRICES SETTLED AT MINES.

MONTREAL manufacturers are at present worried over an alleged coal combine. Dr. W. L. McDougald, manager of the Ogdensburg Coal and Shipping Co., stated a few days ago that the prices of all their coal were fixed at the mines. He said they had nothing to do with the retail price, except that the latter had to be kept at a certain figure. He denied that the wholesalers dictated to retail merchants as to what they should charge. With regard to the statements that merchants who undersold others could not get coal, he stated that if a retailer sold at a figure which the wholesaler knew he could not make money upon, they, for their own safety, could refuse to supply him.

Messrs. Pigeon, Pigeon & Davis, patent solicitors, 71a St. James Street, Montreal, report that 144 Canadian patents were issued for the week ending May 20th, 1913, of which 104 were granted to Americans, 21 to Canadians, 13 to residents of foreign countries, and 6 to residents of Great Britain and colonies. Of Canadians who received patents, 7 were residents of Quebec, 7 of Ontario, 4 of British Columbia, and 3 of Manitoba. In the United States for the same week 611 patents were issued, 12 of which were granted to Canadian inventors.

DEVELOPMENTS IN MACHINERY

A Record of New and Improved Machinery Tending Towards Higher Quality and Economical Production in the Machine Shop, Blacksmith Shop or Planing Mill.

HOTSWAGER WITH HEATING FURNACE.

THE Swaging Machine with special holder and furnace, Figs. 1 and 2, were expressly designed and built by the Langelier Manufacturing Company of Providence, R. I., for swaging by the hot process, spinning spindles, twist drill blanks of both straight and taper shanks, taper reamers, and mills, live axles for autos, round file blanks, motor-cycle pedal pins, pointing for draw-bench, and many similar pieces now either turned by screw machines or forged and repeatedly ground. A large saving of stock can be obtained by this method over other processes where the metal is removed in reducing the profile of the piece, as by swaging there is absolutely no cutting away of the metal. In the making of high speed steel drills and end mills, the saving of expensive stock is enormous. In addition to this saving and to the improvement which takes place in the stock as it is compressed, the machine swages the blanks so very closely to size that in most cases but a few thousandths are required to be ground off to finish the piece completely.

The service required of this machine is particularly severe because the stock is fed into them at forging heat, and to handle the work readily with ample reserve of power, the entire unit has to be ruggedly constructed and every operat-

ing detail foreseen to assure to the machine great endurance. The unit consists of an exceptionally heavy swager, rack and pinion feed holder with pneumatic chucks, and of a continuous rotary gas heating furnace. The swager head is cored around and back of the head to provide a chamber with wide ports through connecting webs and through which a constant flow of cold water, either from city pressure or from a small pump is maintained, while the machine is running to prevent it from heating up. This construction enables the machine to be kept in continuous operation on hot stock, avoiding any shut-downs to cool off. Simple means of controlling the inflow of water and the drainage of heat chamber are provided.

The vital element of the machine—the spindle, is exceptionally large and heavy, of hammered steel, turned and ground, bored throughout its length and slotted diametrically across the enlarged head end. A circular steel ring tongued and screwed in, greatly strengthens this open end. All sides of the slot are lined with hardened steel plates riveted to the spindle. This construction practically incloses the dies and hammer-blocks in a hardened steel box, and insures long life to surfaces in contact. Surrounding the head of the spindle is a circular cage of 10 hardened steel rolls, these being located equidistant from each other, and

kept in their relative positions by the cage lands. The cage is fitted freely into a heavy hardened steel ring which is accurately ground, and forced into the head under a heavy pressure. As a further precaution, to prevent this ring from working loose from the continual hammering it receives, four cap screws with washers bind it firmly to its seat. The cage is reinforced on both ends by circular steel plates, and is designed as light as is consistent with strength. To control the proper die opening, two conical-pointed screws are screwed into the front plate on the slotted end of the spindle, and project into a corresponding hole in the end of the hammerblocks, just the amount necessary to allow the required die opening. Washers of the required thickness are used under the heads of screws to regulate the distance that the cone points of the screws enter the hammerblocks.

The spindle runs in loose, cast-iron, perforated sectional bushings, turned and ground, which slowly creep around with it, giving about 50 per cent. more bearing surface and making it possible and inexpensive to replace when worn out without requiring the entire head of the machine to be sent to the factory, as would be the case with stationary bushings, or if the spindle revolved directly in the bearing in the machine head.

The full power of the heavy flywheel

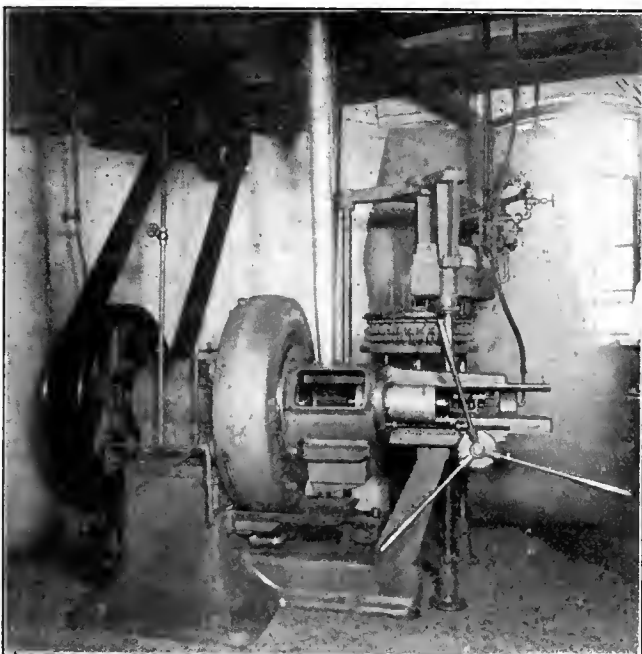

FIG. 1. FRONT VIEW OF HOT SWAGER.

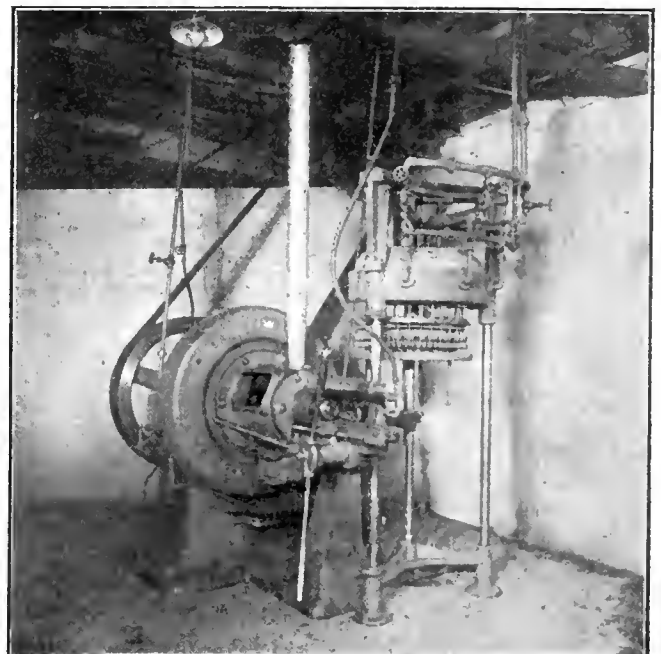

FIG. 2. SIDE VIEW OF HOT SWAGER.

is exerted on dies and on work through this exceptionally strong spindle, explaining the ease and rapidity with which the machine produces the great reduction shown on the different pieces, accurately to size, without chattermarks and at a speed not obtainable in any other process. The circular opening through the spindle back of the dies permits pieces with long parallel portion to pass beyond the dies, and serves as a duct to admit a blast of cooling compressed air on the latter to keep them cool, and furthermore, to blow from them into a scale collecting receptacle, especially provided in the holder, the grit or rough oxide loosened from the stock while it is swaged hot. A special connection is provided at the extreme end of the spindle for leading the air blast into the spindle.

The flywheel is heavy, 38 in. x 71-2 in. for 7 in. belt. The hub of the wheel is split and clamped to the spindle with two $\frac{7}{8}$ -in. bolts. It is also keyed. A clamp nut is provided on the rear end of the spindles, which serves both as a means of taking up end play in the spindle and holding the flywheel in position.

A large oil reservoir, immediately back of the machine, serves to collect the oil which is maintained in circulation through the automatic oil feed pump driven from main spindle of machine, and lets this oil cool somewhat before being repumped to the working parts. The holder is a one-piece casting of tubular design bored out its entire length to provide practically a perfect bearing to the holder piston. The latter, which carries the chucks for gripping the work, feeds the work into the dies, and withdraws it through a steel pinion, meshing with a rack underneath the piston slide, the whole being operated by a triple lever shown. The pinion and rack have stub tooth form of teeth to obtain the greatest possible strength and to resist the sudden shocks which attend swaging.

The chucks are of the self-centering spring type, interchangeable and tightened and released by compressed air. When the holder piston reaches its rear-most position, it automatically shuts off the air pressure, opening the jaws of the chuck so that the blank to be swaged may be readily inserted or withdrawn from the chuck. As it leaves this position for the feeding stroke, the air valve opens, letting the full air pressure bind the chuck on the work. This form of chuck is very rapid in operation, and requires almost no attention at all from the operator. A generous mouth is cast in the holder side to provide ready access to the chucks, and facilitate the insertion of the blanks and the removal of the swaged pieces as well as

to allow access to the dies of the machine for changing same.

The exact distance that the swaging takes places upon the stock may be easily adjusted. It then requires no further attention from the operator until this setting is again changed. The fumes, emitted by the burning of some of the lubricating oil which flows in the dies, are prevented from disseminating in the room where the machine is installed, by a small fume exhauster which is fastened to the ceiling. This exhauster conveys them outside of the building. The holder has been designed as an efficient vital part of the machine, and has been made exceptionally strong to absorb the recoil of the pieces from the dies as well as to make the machine easily operated by unskilled help.

The machine weighs approximately 11,000 lbs., including the holder, and the flywheel runs at from 250 to 280 r.p.m. The floor space occupied is 8 feet x 5 ft. overall, the countershaft driving pulley is 30 in. in diameter for 7 in. belt. As a part of the unit, a continuous rotary gas heating furnace has been designed for heating the blanks to the proper temperature required by the stock being swaged. Several changes of heating and feeding speeds are provided, through crown gears which permit of accelerating or decelerating the speed in accordance with variations in the diameter and character of the stock and the length to which it is to be heated, avoiding all time losses between swaging passes. This furnace is made in two types, one for heating carbon steel, and the other with more burners and with many modifications for heating high speed steel.

The proper temperature can be closely gauged by regulating the air and gas supply through suitable valves. About one half of the dial may serve as loading stations, while through the other half the pieces are being subjected to the heating blasts from the burners. Special forms of fire brick are used which almost entirely enclose the blanks, preventing any waste of heat. The exact length and time of heating may be closely gauged and different lengths of pieces may be used in the same furnace by a suitable elevating and lowering dial on which the pieces rest. The dial is kept in motion through pulleys at the base of the furnace belted from the main countershaft overhead.



Welland, Ont.—The Town Council have been informed by H. E. Timmermann, Hydro-Electric engineer, that to bury the wires on the east and west main streets would cost \$16,500.

Personal

Geo. C. Burnham has severed his connection with the firm of Kilmer, Pullen & Burnham, Ltd., Toronto.

H. N. Ruttan, city engineer of Winnipeg, has been elected a member of the council of the Institution of Civil Engineers, London, Eng.

S. F. Fortner, a foreman of the London Bolt & Hinge Works, Toronto, and employed by that company for a number of years, has resigned.

Mr. F. Jno. Bell, general manager of the Canada Wire & Cable Co., has sailed for London, Eng., on business connected with his company. Mr. Bell will be absent about six weeks.

F. R. Elbert has resigned as superintendent of Bowes, Jamieson, Ltd., iron founders, Hamilton, Ont., to accept a position with the Ohio Foundry & Mfg. Co., Steubenville, Ohio.

Walter Macleod, the manufacturer and inventor of several oil furnaces and kindred lines for which the Canadian agents are Mussels, Limited, Montreal, visited last week on business widening pursuits and was welcomed by the trade.

Alexander Gibb, Montreal, has just returned from a trip to the New England States, having spent much time in Boston looking over the large manufacturing plants there. Mr. Gibb is a keen observer and speaks highly of some of the factories visited.

A. D. Swan, until recently assistant chief engineer of the Montreal Harbor Commission, and Captain P. Sidney Morrissey, left for New York en route to Chile on Friday last. Mr. Swan will report on sites for harbors in South America for a British Company.

James Veitch, formerly of the Bruce, Peebles Electric Co., Edinburgh, Scotland, and latterly on the staff of the Donaldson Liner S.S. *Cassandro*, has joined the engineering staff of Chas. F. Gray, consulting electrical engineer, Union Trust Building, Winnipeg.

Lawford Grant, president and managing director of the Canadian Insulated Cables, Ltd., has resigned to take an important executive position with Eugene Phillips Electrical Co., of Montreal. Mr. Grant has been thirteen years with the British Helsby Cables Co., which is the parent of the concern which he formed in Canada about six years ago. He will retain his official position as president of the company he is leaving. Mr. Grant has traveled the Dominion over, and has made many friends. Before coming to Canada, he carried out some important electrification work for the British Government at the Island of Malta.

HEAVY DUTY SHAPER.

A NEW heavy duty shaper has been brought out by the Stockbridge Machine Co., Worcester, Mass., which is designed to meet the requirements of the heaviest kind of work. A number of new features have been embodied so as to provide for the large amount of power which the machine will develop at the tool point.

To protect the shaper against risk of breakage, a new cross feed has been designed, making it impossible to feed against the cut. This mechanism is illustrated in Fig. 1. A reciprocating motion is imparted to (A) through the usual type of cross feed rod. The click (B), in turn, is moved over the internal ratchet gear (C), giving to it an intermittent motion; the amount of motion given gear (C) being determined by the amount of feed which is adjustable. Motion given to gear (C) is communicated to cross feed screw (H), either directly through intermediate gear (F) or through the two intermediate gears (F) and (G). By this means the direction of feed is changed. In order to secure these two positions in a train of gears, the two intermediate gears are supported on a rocker, which may be thrown to either of three positions; one as shown with the handle at (D), when feed is direct through gear (F); another, by moving handle through an arc of 180 degrees and feeding through two intermediate gears (F) and (G). When handle is in 90 degree position, (E) gears are neutral, and yoke (L) at the same time has been raised sufficiently to throw, automatically, the click (B) out of engagement with gear (C). In this way all possibility of gears getting caught when changing direction of feed will be appreciated by every mechanic who has had occasion to use a shaper on work where it was desired to feed across in one direction, and then back

without having each time to change cross feed rod or change direction of feed by adjusting screw. With this motion the only operation necessary to change direction of feed is to throw handle to one position or the other.

metal enough to absorb vibration, and gives to it sufficient strength to hold the weight put upon it without springing. The base is slightly concaved on the outside, and has a pan cast on the inside, absolutely protecting the floor

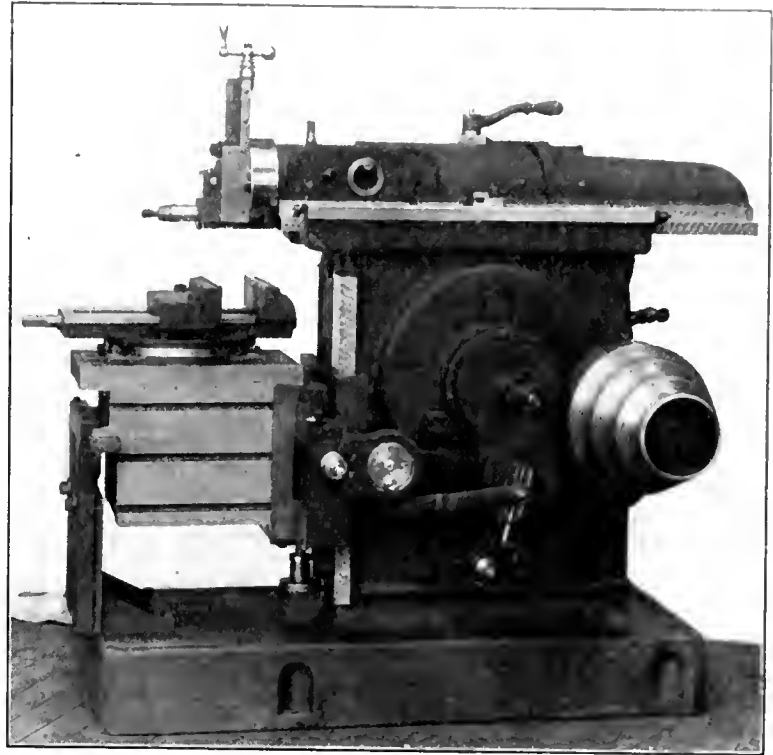

FIG. 1. STOCKBRIDGE 20-INCH SHAPER.

which can be accomplished almost instantly and without stopping shaper. Another advantage is that the operator cannot feed on the cut. By eliminating this possibility, there is no danger of broken cross feed parts, since it is the "cut feeding" that does sometimes so much damage.

The base feature is in keeping with the liberal proportions of the rest of the shaper. Its unusual depth provides

upon which the machine rests from becoming oil soaked. Oil is drained to a pocket from which it can be drawn off.

The driving cone is supported on an independent bearing built out from the shaper column. The belt pull is carried by this bearing entirely, the driving shaft being driven by a two-jaw clutch (F), shown in Fig. 2, and carried by an independent bearing. The details of construction consist of (A), the cone

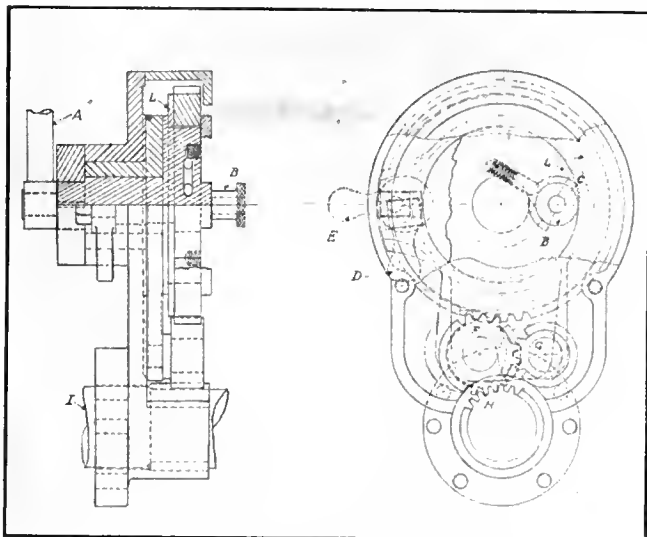

FIG. 3. FEED MECHANISM DETAIL.

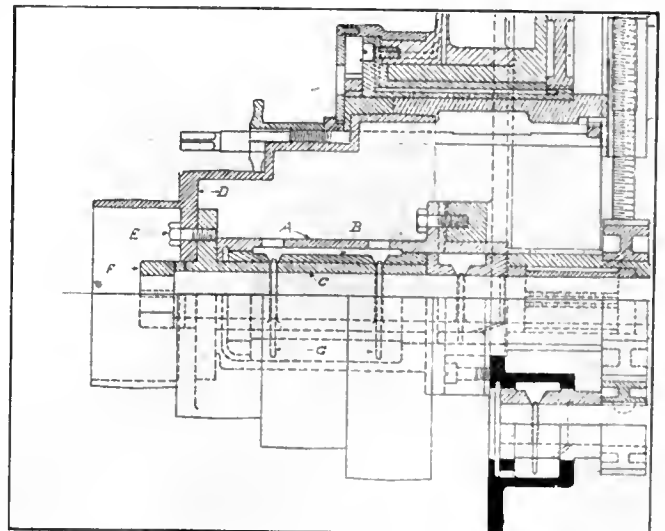

FIG. 2. CROSS SECTION THROUGH CONE PULLEY, ETC.

bearing, which is bolted to the column of the machine; (B), the bushing which slips over this cone bearing, and (C), the cone hub which fits inside bearing. Cone (D) is bolted to the cone hub by means of four bolts. A deep oil well with oil rings (G) keeps the bearing flooded with oil. All shaft (E) bearings are bushed and self-oiling. The shaper is equipped with the Stockbridge patented two-piece crank motion, giving a 3-1 quick return, and the crank is provided with a double bearing eliminating all overhang.

Further equipment consists of a telescopic screw with ball thrust bearings for raising and lowering table. The top of knee is made separate, and hooks over saddle, relieving the knee bolts of practically all strain. The ram can be positioned and adjusted to any length of stroke, and taper packings adjusted from either end by means of screws take up all wear and assure perfect alignment. The table support automatically adjusts itself to any height, and gives a bearing throughout its entire width.

The actual length of stroke is $20\frac{3}{4}$ in.; the vertical traverse of table, 13 in., and the net weight of the machine, together with countershaft, 3,750 pounds.



EDUCATION IN ACCIDENT PREVENTION WORK.

By Robert W. Campbell.

TO understand properly the purpose and effect of measures taken toward accident prevention, it is necessary briefly to analyse accidents. Accidents are of two kinds, the preventable and the non-preventable. In the preventable accidents there are two principal causes:

First, the failure of the employer to provide and maintain proper working conditions and proper and efficient safeguards upon dangerous machines or appliances.

Second, ignorance and carelessness on the part of the employee.

As to non-preventable accidents, a serious study of their causes and effects is important; for, while there may be no known method of preventing them, such accidents can still be anticipated and their effects diminished or modified. It would seem, therefore, that the industrial concern which seriously takes up the problem of accident prevention must undertake to provide and maintain proper working conditions and proper and efficient safeguards upon dangerous machines and appliances, and to educate its employees and inculcate in them habits of caution. This, it will be seen, requires a definite plan and a comprehensive organization to formulate and carry out such a plan. It would not be

appropriate in this paper to discuss the details of mechanical and physical protection which should be provided in industrial plants, as these naturally vary with the character of each particular industry.

Necessity of Education.

The element of education in accident prevention work is one which cannot be controlled by compulsion or by legislation, and must be the result of a well organized effort and the establishment of a fine esprit de corps throughout the industrial plant. Reliable statistics show that at well-safeguarded industrial plants from eighty-five to ninety per cent. of the accidents which occur are caused by the carelessness or ignorance of the men themselves, and that even in plants not so well protected, the percentage of accidents so caused is very large. It, therefore, follows that while safeguarding is important and absolutely essential in any satisfactory "Safety" work, the problem of the education of the men, and the inculcation in them of habits of caution, is the graver of the two.

Superintendents and Foremen.

The burden of education and inculcation of habits of caution rests very largely upon the plant superintendent and his foremen. The attitude of the superintendent and the foremen toward the prevention of accidents will be reflected by the workmen just as accurately as their attitude toward the getting out of production is reflected. If the superintendent treats safety matters lightly, his assistants will treat them lightly. If he shows a strenuous desire to have working conditions safe, and precautionary rules observed; if he makes the prevention of accidents one of the most important features of his department, then his foremen will reflect that feeling, and will see that the men observe the precautions which are known to be necessary to the prevention of accidents. By seeing that the men observe these precautions, and by talking with them about the necessity of keeping conditions safe, and looking out for their own and other's safety, the foremen will gradually inculcate in them such habits of caution, that the number of accidents occurring in that department will be reduced to a minimum. The leaven, therefore, must begin its work at the top and work downward through superintendent and foremen to the men.

There are many different ways in which this problem may be attacked: First, by requiring the observance of concise and well worked out rules for safety in operation as well as the consistent use of all safety devices. Second, by keeping the subject of safety constantly before the eyes and in the minds of the men; and third, by endeavoring

to obtain the hearty co-operation of the men, to the end that each may constitute himself his brother's keeper.

Methods of the Illinois Steel Co.

The Illinois Steel Co. has provided a Book of Standard Safety Devices, Rules Governing Construction (relating to safety), and Safety Rules governing operations, and requires its employees to be familiar with their requirements. Each new man after being employed, is provided with a set of safety rules of the company. He also works for some time under the direction of an experienced man, one of whose prime duties is to help the new man to understand the rules and apply them to his work. After working ten days or two weeks, each new man must take an examination on the safety rules and their application to the plant in general, and to his work in particular.

From the time a man enters the gate of the plants until his departure at night he has constantly before him some reminder respecting safety. At many of the plants of the company safety mottoes are installed at or over the entrance gates, and danger signs and cautions are placed throughout the plants wherever necessary. From time to time the foremen also are examined by the safety inspector, department superintendent and assistant general superintendent of the plants as to their knowledge of and familiarity with the safety rules, and foremen, who persistently fail to show familiarity therewith, are either discharged or given other work. To stimulate or interest the foremen and workmen in the study of these rules safety buttons or badges are distributed to any foreman or workman who is able to pass a satisfactory examination upon the safety rules.

At some of the plants of the company, for the purpose of further stimulating interest in safety matters, where a department has not had any accident during the month incurring a loss of ten days' time or more, a recognition is made of this record by the presenting of boxes of cigars for distribution among the foremen and men. These cigars are called "Boosters" and have a "safety" band upon them. At one of the plants, an experiment is now being tried out, under which monthly prizes, consisting of match boxes, sanitary drinking cups, bill books, etc., bearing the "Safety First" motto and the company monogram, are given to every man in a department which during the month has been successful in having no men off for a longer period than seven days, on account of accident. Congratulatory letters are also sent to the superintendents of such departments by the chairman of the safety committee.

Safety bulletin boards have also been placed in conspicuous places in and about the plants. Upon these boards, bulletins issued by the plant management respecting safety matters are posted, as well as lists of departments having a record of no ten days' or more accidents during the month and other safety data. Newspaper clippings are also used to show the occurrence of industrial accidents in other plants throughout the United States, together with a photograph of the device in use or the rule in effect at the plants of the Illinois Steel Company which should prevent the occurrence of a similar accident. These bulletin boards seem to interest the men greatly; and in good weather, when the men are "spelled" or at the lunch hour, many of them will be found reading the items upon these bulletin boards with great care.

It is the aim of the company, as far as possible, to keep the motto, "Safety First" before the eyes and in the minds of its employees at all times. In furtherance of this plan, all printed forms which are used by foremen or men in and about its plant have some safety motto or emblem upon them. For instance, on "loan slips," i. e., orders for men loaned from one department to work in another department temporarily, the motto appears in red: "Tell the men of the dangers of this work and how to avoid them." On repair orders for repairing machinery is shown the motto: "Replace all safeguards before leaving the job."

At several of our plants, at the beginning of each year, safety calendars, upon each tab of which there are printed appropriate safety mottoes and rules, are distributed among all the men in the plant, and are also distributed among the schools and public places in and about the communities where the plants are located.



PURCHASE AND SAMPLING OF COAL.

LARGE users of coal will be interested in Bureau of Mines Bulletin No. 63, "Sampling of Coal Deliveries, and Types of Government Specifications for the Purchase of Coal," which has recently been issued. The Federal Government, which purchases \$8,000,000 worth of coal annually, buys more than half of it under specifications, and has gone deeply into the question of sampling and analysing coal. George S. Pope, the engineer in charge of such investigations and the author of the bulletin makes the following statements:

To determine with the utmost accuracy, the ash content and heating value of a quantity of delivered coal would require the burning of the entire quantity, and special apparatus arranged to

measure the total heat liberated, or would require crushing the whole quantity, and reducing it by an elaborate scheme of successive crushings, mixings, and fractional selections to portions weighing approximately 1 gram, the minute quantity which the chemist requires for each determination. Either of these procedures is obviously impracticable, if the coal is to be used for the production of heat and power. The method actually employed is to select portions from all parts of a consignment or delivery of coal, and to systematically reduce the gross sample, obtained by mixing these portions, to quantities that the chemist requires for making ash determinations or that can be burned conveniently in the calorimeter, an apparatus for determining the heating value. The gross sample should be so large that the chance admixture of pieces of slate, bone, coal, pyrite, or other impurities in an otherwise representative sample will affect but slightly the final results. Increasing the size of the gross sample tends toward accuracy, but the possible increase is limited by the cost of collection and reduction. In reducing the gross sample by successive crushings and halvings or fractional selections, the object is to procure a small laboratory sample that, upon analysis, will give approximately the same results as the gross sample itself, or, in fact, the entire quantity of coal from which the gross sample was obtained.

Recognizing the importance of the method of sampling as being a definite commercial procedure, and of having the method clearly set forth in the specifications to become a part of the contract, and recognizing also the desirability of insuring uniformity and similarity in the specifications used by the different branches of the Federal service for the purchase of coal, representatives of the executive departments and independent establishments of the Government held a conference under the auspices of the Bureau of Mines in February, 1912, for the purpose of discussing these and other features of the specifications. At this conference committees were appointed to prepare specifications in accordance with the views of the members. It was recognized at the conference that in general specifications, such as were recommended, certain requirements had to be of wide application, as the specifications cover such a wide variety of conditions, not only as to character and quality of coal but as to type of furnace equipment, size of deliveries, methods of delivering, etc.

The specifications which were used for the purchase of coal on the heat-unit basis prior to the fiscal year 1912-13 were on the B.t.u. (British thermal unit) "as received" basis; that is, payment for delivered coal was directly affected

by the moisture content of the sample received by the laboratory. This method was based on the assumption that the moisture in the samples collected at the time of weighing and delivery could be preserved with slight loss during the storing and subsequent working down of the gross sample to a quantity convenient for transmittal to the laboratory and in its later treatment in the laboratory. From experiments that have been made and from a large mass of data, it is known that the moisture content reported by the laboratory may be as much as 5 to 10 per cent. lower than that actually contained in excessively wet or high-moisture coal at the time of weighing.

As a sample loses moisture, its B.t.u. "as received" value correspondingly rises, with the result that the price for delivered coal determined on the "as received" value is, with rare exceptions, higher than that warranted by the quality of the coal at the time of weighing. As a general statement, payment based on the "as received" B.t.u. value will be higher than warranted, unless the sampling and laboratory work can be carried on under conditions that minimize moisture loss, as under freezing temperatures. Recognizing the uncertainty involved in taking the moisture determination in the laboratory as representative of the moisture content of the delivered coal and the consequent possibility of payment of a higher price than is warranted, the Bureau of Mines recommended to the executive departments and independent establishments of the Federal service that the heating value in the coal specifications for the fiscal year 1912-13 be on the "dry coal" basis.

In preparing these specifications, the fact was recognized that the amount of moisture contained in coal produced from day to day from the same mine, or group of mines working the same bed, is largely accidental, and is a matter over which the buyer and seller have only slight control. However, in order to place a negative value on high moisture coals, and to protect the Government against the delivery of coals containing excessive amounts of moisture, the specifications require the bidders to specify the maximum moisture content in coal offered. This value becomes the standard of the contract. If coal of uniform B.t.u. "dry coal" value is delivered on a contract, the contractor receives the advantage on any delivery in which the moisture content approaches the maximum specified, because he is paid for the weight of water contained in the coal in excess of a normal amount, whereas if the coal is very dry, containing less than the normal amount of moisture, the purchaser receives the advantage.

The MacLean Publishing Company

LIMITED

(ESTABLISHED 1888.)

JOHN BAYNE MACLEAN - - - - - President
M. T. HUNTER - - - - - General Manager

PUBLISHERS OF

CANADIAN MACHINERY AND MANUFACTURING NEWS

A weekly newspaper devoted to machinery and manufacturing interests, mechanical and electrical trades, the foundry, technical progress, construction and improvement.

H. V. TYRRELL - - - - - Business Manager
PETER BAIN, M.E. - - - - - Editor.

OFFICES:

CANADA	GREAT BRITAIN
Montreal, Rooms 701-702 Eastern Townships Bank Bldg.	London, 88 Fleet Street, E.C. Phone Central 12960 E. J. Dodd
Toronto, 143-149 University Ave., Phone Main 7324	UNITED STATES
Winnipeg, 34 Royal Bank Bldg., Phone Garry 2313	New York, R. B. Huetts, 115 Broadway, New York, N. Y., Phone 2209 Rector
Vancouver, H. Hodgson, 2640 Third Ave. West.	Chicago, A. H. Byrne Room 607, Marquette Bldg. 140 S. Dearborn St., Chicago

CABLE ADDRESS: Macpubco, Toronto. Atabek, London, Eng.

SUBSCRIPTION RATE:

Canada, \$2.00; United States, \$2.50; Great Britain, Australia and other colonies, 8s. 6d. per year; other countries, \$3.00. Advertising rates on request.

Subscribers who are not receiving their paper regularly will confer a favor on us by letting us know. We should be notified at once of any change in address, giving both old and new.

Vol. IX. JUNE 12, 1913 No. 21

PRINCIPAL CONTENTS.

Overhead Expense Distribution in Manufacturing	611-612
Conservation of Mechanies	613-614
Ontario Steel Products Co. Charter	614
Breaking off Tool Bits	614
Canadian Railroad Construction	614
Removing a Tight Arbor	614
High Temperature Measurement, or Industrial Pyrometry	615-616
Prevention of Industrial Accidents	616-617
Recent Judicial Decisions	617
Helping Young Men to Find Their Particular Vocation	618-621
Equipment of Laundries	621-622
Self-Equalizing Expansion Joint	622
New Incorporations	622
Machine Shop Methods and Devices	623-624
Two Aids to Vise Work in the Miller...The Use of Fitting Nuts...Hint for Riveting...Drilling Fan. Spindle Blades.	
General	624
St. John's Fort Facilities...Toronto-Ottawa Line...Coal Prices Settled at Mines.	
Developments in Machinery	625-628
Hot Swager with Heating Furnace...Personal...Heavy Duty Shaper.	
General	626-629
Education in Accident Prevention Work...Purchase and Sampling of Coal.	
Editorial	630
Industrial and Construction News	631-636
Engineering...Electrical...Municipal Railways and Bridges...General Industrial...Waterworks...Refrigeration...Trade Gossip...Building Notes...Woodworking...Contracts Awarded...Tenders...Marine...Obituary...Catalogues...Book Reviews.	
Selected Market Quotations	637-638
The General Market Conditions and Tendencies	638

ACCIDENT PREVENTION.

AN article in the present issue of Canadian Machinery sets forth the steps taken at the plant of the Illinois Steel Co., in order to reduce the accident record there to a minimum. Occasion is taken in the course of the paper to point out that the operatives themselves can contribute more perhaps to such a consummation than all the established safeguards to machines and equipment, and no one conversant with the routine of our factories and workshops generally, will find fault with the expressed opinion.

The sense of self-preservation is usually allowed to be a strongly inherent feature of every man's make-up, yet, strange it is, that indifference and a familiarity with environment and occupation, tends to dull and blunt its application in practice. The installation of machinery safeguards by an employer should not be looked upon by the operative as a solution of the question and that because the more dangerous parts are fenced in, little precaution need further be exercised. Safeguarding has a limit, both as to the extent to which it can be done on each individual machine, and to its particular necessity on other machines or equipment. This being so, the operative should see it to be his duty to supplement what may not be possible of accomplishment in the foregoing direction by his attitude and alertness of head at all times. Individually and collectively, employees have a responsibility in this matter that nobody else can shoulder for them, and as the responsibility does not entail any irksome obligation on their part, but rather the reverse, we look to see an increased response to and co-operation with the employer in his effort to minimize suffering to the fullest possible degree.

Concurrent with accident prevention schemes, there are now in operation in many of our larger industrial enterprises, systems whereby medical advice and attention are given employees free of charge, it having been recognized that the keeping of a man physically fit, contributes not only to his effectiveness as an operative, but to a reduction of his liability to meet with accidents more or less severe.



WORKMEN'S HOUSES.

SOME time ago, two large manufacturing concerns in Welland, Ont., wrote to the Industrial Commissioner, saying: "We wish to extend our plant," or "We wish to locate in your town, but hesitate to do it since there are not sufficient decent houses to accommodate families there already, to say nothing about those we wish to bring into the town. We want a solution to this problem, and it depends on what you do whether we locate in your town." Welland of late has been suffering from growing pains, and particularly in this spot. Because of its ideal location, manufacturers have been flocking there at an astounding rate, so that a large town has sprung up, which is a phenomenon. It has princely industries, but the employees have nowhere to lay their heads. Houses are required by the hundred, but few will dare to erect them as an investment, as workmen are seldom able to pay more than a couple of hundred dollars cash down.

It may be of interest to Welland to know that she lost a splendid industry as a result of this deplorable condition. A large American nut and bolt concern, who are now going full speed ahead in an Ontario town, practically decided on Welland as the best location for their Canadian branch; but when the heads with their wives paid a visit across the border, they were so shocked, that a domestic revolution would have taken place, had not the location been changed. So Welland lost an industry. This housing problem has led more or less philanthropic persons in various towns and cities to form companies for the express purpose of building neat, comfortable cottages for workmen, to rent at a reasonable figure. One was formed in Toronto with a capital of a million dollars, \$800,000 bonds of which were guaranteed by the city. The same is being done in Saskatoon where 300 houses are to be built at a cost of \$1,800 each. This is one of the most serious problems Canada will have to face, and once again faces are turned across the Atlantic for patterns. Port Sunlight, Bourneville and Letchworth, the model cities of England, will soon have their prototypes in Canada.

INDUSTRIAL ^A_N^D CONSTRUCTION NEWS

Establishment or Enlargement of Factories, Mills, Power Plants, Etc.; Construction of Railways, Bridges, Etc.; Municipal Undertakings; Mining News.

Engineering

Toronto, Ont.—The Metallic Roofing Co. will build an addition to its factory to cost \$12,000.

London, Ont.—The Dennis Wire and Iron Works will erect a factory, costing \$20,000. Plans are being prepared.

Hamilton, Ont.—Lomas & Nelson, brass founders, have opened a plant on Adams Street, for the manufacture of electric and gas fixtures, art metal ware, etc.

Woodstock, N.B.—The foundry and machine shop of Dunbar Foundry Co. were partly destroyed by fire on Friday, May 30th. Considerable insurance was held.

Welland, Ont.—Provided the town makes them a concession, the Electric Steel and Metals Co., Ltd., will erect a plant to manufacture steel castings, tool steel, etc., employing 200 men.

Sarnia, Ont.—Work has commenced on the pipe lines to bring crude oil from the Ohio Valley to Sarnia for the Standard Oil Co. This company is building docks on the water front, with machinery for handling coal and oil.

Brantford, Ont.—The Brantford Machine and Foundries, Ltd., will erect machine shop, 10,000 sq. ft., and foundry, 8,000 sq. ft., one storey, costing \$20,000. H. B. Rowell, Brantford Anticycles, Ltd., is manager.

Port Moody, B.C.—The Canada Smelting Co., composed of local capitalists, will erect a large zinc smelter to handle the deposits from Lynn Valley. Newton W. Emmers, of the Lynn Creek Zinc Mines, is interested in the company.

Canora, Ont.—The Canora Mfg. Co., Ltd., commenced building operations last week on a general machinery and foundry works, in which it will manufacture steel culverts and high-pressure water plants for fire and other purposes.

Saskatoon, Sask.—The Perfect Removable Bar Cylinder Co. will erect a plant to manufacture a new cylinder for threshing machines. The parent plant is situated at Spokane, Wash., and it is planned to move the whole concern to Saskatoon. W. D. Hale and A.

C. Harris, of the Hale-Harris Co., are shareholders.

Electrical

Clinton, Ont.—The town now owns an electric plant, and will do its own pumping at the waterworks.

Port Coquitlam, B.C.—Messrs. Purdy and Williamson, of Vancouver, are erecting a sub-station for the Western Canada Power Co.

Saskatoon, Sask.—F. Maclure Sclanders, secretary of the Board of Trade, says that the telephone plant in this city will be extended.

Aurora, Ont.—The ratepayers will shortly vote on a by-law to provide for a supply of electric power from the Toronto and York Radial Railway Co.

Regina, Sask.—Construction work on the new city power house in Lakeview will commence at once. The floor area will measure 174 by 120 ft.

Estevan, Sask.—The Town will supply day power for the first time this month. There should be a good demand for electric motors.

Kelowna, B.C.—By-laws for raising the sum of \$1,000 for extending the electric light system and \$1,000 for extending the water system will be submitted on July 1st.

Shawinigan Falls, Que.—The Shawinigan Water and Power Co., Montreal, are adding to their power plant, the company themselves being builders and architects.

River Glade, N.B.—R. A. Corbett, St. John, has been awarded the general contract for the power house for the Jordan Sanitarium. Architects, F. Neil Brodie, St. John.

Iroquois Falls, Ont.—Details in regard to the new development of the Abitibi Pulp and Paper Co., at Iroquois Falls, show that of the 17,500 horsepower which will immediately be developed, about 15,000 will be used to run 18 ten-ton grinders, and in addition about 3,000 horse-power of electrical energy will be utilized. The building will be completed by December 1.

Hamilton, Ont.—The Dominion Power and Transmission Co. will build

a \$1,000,000 steam auxiliary plant at once on the site of the old power house of the Street Railway. It will have a capacity of 30,000 h.p., with provision for other units. The machinery will be up-to-date, and will include a steam turbine.

Montreal, Que.—The Montreal Light, Heat and Power Co. will build a gas plant of 4,000,000 cubic feet per day, and a central auxiliary steam station, capacity 25,000 h.p., to be increased to 50,000 h.p. The company also contracted with the Cedar Rapids Mfg. and Power Co. for the supply of 60,000 h.p., for which they will erect a steel power transmission line.

Water Works

Burlington, Ont.—The village council are planning a sewerage system, the engineer in charge being J. J. McKay, Hamilton.

Watrous, Sask.—The ratepayers have passed by-laws providing \$70,000 for completion of the waterworks and sewerage system.

Port Moody, B.C.—The city council will utilize the water from Noon Creek for its future supply. Contracts for a waterworks system will be called shortly.

Point Grey, B.C.—The town will buy the sewer and waterworks at Shaughnessy Heights from the C.P.R.; \$324,606 having been appropriated for this purpose.

Port Coquitlam, B.C.—Plans and specifications of a preliminary waterworks system are complete, and call for an expenditure of between \$20,000 and \$25,000, the mains to be 12, 8 and 6 ins. in size. Tenders were opened on Tuesday, June 10th. City Engineer Kilmer.

Winnipeg, Man.—\$14,144,903 is the estimate of City Engineer Ruttan for bringing a supply of water of 25,000,000 gals. per day from Shoal Lake to Winnipeg, by gravity system. There will be two pipe lines. The first line would be finished in four years if rushed. The second is intended as a stand-by in case of accidents.

If only one be built, it is recommended that a storage reservoir of 25,000,000 gals. capacity be constructed.

Municipal

Montreal, Que.—The City Council at its regular meeting on Monday next will be asked to adopt a recommendation of the Board of Control calling for the expenditure of an additional \$1,500,000 for machinery with which to complete the equipment of the new civic pumping station in Point St. Charles. Already \$2,500,000 has been obtained through a loan for the aqueduct improvements, and for the pumping and lighting equipment. The Board also ask in a recommendation sent to the Council for the apportionment of \$1,000,000 towards the widening of the aqueduct. The entire cost of this work will be over \$2,000,000, but the balance will not be voted until nearly all of the first million has been put into the undertaking. The contract time for the work is three years.

Building Notes

Elmira, Ont.—The Elmira Furniture Co., Ltd., will build a \$15,000 addition of three storeys, 100 x 50. Architect, C. Knechtel.

Regina, Sask.—The Presbyterians have sufficient money to warrant the erection of a \$1,000,000 college, plans for which are being prepared.

Winnipeg, Man.—A store, ten storeys in height, costing \$3,250,000, will be built on Portage Avenue by the Hudson Bay Co., who will also proceed with the erection of its Victoria, B.C., store, costing \$250,000.

Ottawa, Ont.—The new building of the American Bank Note Co., will be four storeys high, with basement, and the cost will be about \$100,000. J. C. Low and A. Garvok have the general contract, and the Dominion Bridge Co. the steel contract.

Saskatoon, Sask.—The University governors have decided to build a \$60,000 extension to the present engineering building, measuring 72 by 128 ft., of brick, three storeys in height, to be completed by October 1. The addition will contain laboratories.

Wood-Working

Sawyerville, Que.—The Bejebseot Lumber Co. are building a new saw mill here. A. Cromwell, of Cookshire, having the contract.

Wiarnton, Ont.—J. P. Newman is erecting a large addition to his plant, and intends to instal the most modern machinery obtainable.

Eburne, B.C.—James Parker, late of Seattle, has purchased a site at Eburne, on the Fraser River, and will instal four shingle machines.

Fort Steele, B.C.—The Bridges Lumber Co. is erecting a mill on the Kootenay River, just west of Fort Steele. The capacity will be about 45,000 feet daily.

Calgary, Alta.—The box factory belonging to the Alberta Box Co., corner 11th Avenue and 12th Street East, Calgary, was recently damaged by fire to the extent of about \$12,000.

Calgary, Alta.—The Western Builders' Insurance and Loans, Ltd., 408 MacLean Block, are erecting a planing mill to cost \$5,000. The building will be of one storey, 50 x 130 feet. Electric power machinery will be required.

Buckingham, Que.—The Buckingham Planing Mill, Ltd., are erecting a new mill near the site of their present buildings, measuring 30 x 100 feet, to be equipped with up-to-date machinery. The officers of the company are C. E. Parker, president; W. L. Parker, vice-president, and W. H. Parker, treasurer.

Outremont, Que.—A lumber factory to cost \$9,500, is being constructed on Rockland Avenue by Warren Bros., the owners. The building will be on a site 52 x 175, and will consist of two storeys, the structure being of brick with concrete foundation. A boiler house of reinforced concrete will also be built. It is intended to manufacture woodwork for houses, such as doors, mouldings, and other interior finish.

St. John, N.B.—The Belgo Canadian Pulp and Paper Co., who recently purchased 500 square miles of timber limits known as the Metabetchonan limits, from Sharples, Power & Calvin, for about \$500,000, intend to erect a sulphite plant to operate upon the raw material secured from these limits. They will also erect a new building alongside of their present plant, to house two more paper machines which they intend to add to their equipment.

General Industrial

Port Haney, B.C.—The Port Haney Brick Co. are making considerable additions to their plant.

St. John, N.B.—The Oil Motor & Mfg. Co., Ltd., will build a factory. F. Neil Brodie is architect.

Oakville, Ont.—The Cedar Valley Pressed Brick Co., Toronto, will build a plant on Appleby Road.

Merlin, Ont.—A brick and tile plant, to cost \$30,000, will be started by H. P. Bestaph, of Tilbury, and M. Ryan, of Chatham.

Humboldt, Sask.—E. Selby is ordering machinery for a steam laundry, which he is erecting here at a cost of \$5,000.

Toronto, Ont.—The Toronto Pleating Co., 600 Yonge Street, will erect a two-storey brick factory at No. 14 Breadalbane Street.

Montreal, Que.—The General Fire Extinguisher Co., 175 McCord St., will build a plant, 127 x 300 ft. Architect, Robt. Findlay.

Port Colborne, Ont.—The Maple Leaf Milling Co. have awarded contracts for machinery to the Canadian Allis-Chalmers Co.

Steveston, B.C.—The new plant of the B. C. Pressed Brick Co. has installed new machinery, and have begun operations, using the Kommick system.

Edmonton, Alta.—The Masters Piano Co., who have a plant on Jasper Ave., are making several additions for repair work, and purpose building a new plant this year.

Fort Frances, Ont.—The E. W. Bachus Co., which has large interests at International Falls, Minn., and Fort Frances, will erect a 100-ton pulp mill at Kenora, Ont.

Toronto, Ont.—J. M. Loose & Son, manufacturers of piano actions and kindred products, have purchased a site, 250 x 134 ft., upon which to erect a new factory.

Regina, Sask.—The Egon Von Pappa Co. are negotiating for a site on which to build a brick plant, costing \$20,000, and to instal machinery at a cost of \$80,000.

Carman, Man.—The Canadian Tile and Fire Proofing Co. will build a plant costing \$75,000, and employ 50 workmen, if the ratepayers will exempt them from taxation.

Ottawa, Ont.—The Department of Public Works will erect two terminal elevators at Moose Jaw and Saskatoon, with a capacity of three to four million bushels each day, and costing \$1,000,000. Another will probably be located at Calgary. A transfer elevator will be erected at the Pacific Coast for grain business, when the Panama Canal is opened; while another will be built at Port Nelson for wheat.

Calgary, Alta.—The Swift Current Construction Co., the Canadian end of the Western Construction Co. of Reno, Nevada, will build a plant here for the manufacture of concrete brick, tile, sewer pipes, etc. D. W. Leslie is president of the Board of Trade.

Saskatoon, Sask.—The Saskatchewan Garment Mfg. Co., capital \$50,000, will build a plant employing ultimately 150 hands, to manufacture overalls, etc. The building will measure 100 by 50 ft. S. Selcer, formerly of the Alaska Fur Co., Minneapolis, is president. Machinery is being brought from the States.

Bridgeburg, Ont.—The Monarch Belt Co., operating large plants near Buffalo, has a representative looking over numerous sites here for the purpose of locating a Canadian branch. The concern will manufacture belts of all kinds. If the sale goes through, a large factory covering three acres will be erected in a short time. Sites have also been inspected in Hamilton, Welland and Port Colborne, but it is understood that the firm prefers Bridgeburg on account of its being adjacent to Buffalo.

Toronto, Ont.—The Provincial Paper Mills Co., Ltd., has been incorporated with a capital of 5,000,000, being the combined stock of the St. Lawrence Paper Mills Co., Ltd., and the Barber Paper and Coated Mills Co., Ltd. The company secures control of the former's mills at Mille Roches, near Montreal. The Montrose Paper Co. at Thorold. The Barber Paper and Coated Mills, and The Canada Coating Mills at Georgetown, Ont. The managers are Fred. Duncan, formerly of Kalamazoo, and I. H. Weldon, of Toronto.

Railways--Bridges

Weyburn, Sask.—Plans are being prepared by the town for a bridge, costing \$25,000, of structural steel and reinforced concrete construction.

Victoria, B.C.—The Victoria and Sidney Railway Co. will build a larger car barge for the ferry between Sidney and New Westminster, and make improvements in the passenger service.

Kingston, Ont.—The Utilities Committee will ask the Hydro-Electric Power Commission of Ontario to submit estimates on the cost of an interurban electric railway between this city and Cornwall.

Montreal, Que.—F. Stuart Williamson, consulting engineer, Montreal, has supplied the Board of Control with plans for an underground railway ser-

vice for the city. He figures an outlay of \$20,000,000 on 12½ miles of underground double track lines.

Truro, N.S.—There is considerable activity on the Dominion Atlantic Railway, the C. P. R. subsidiary. New roadbeds, bridges, rails, stations, round-houses, workshops, etc., are being laid and built. The bulk of the changes are being made between Digby and Windsor.

Contracts Awarded

Hamilton, Ont.—W. H. Cooper is general contractor for the Otis-Fenson Elevator Co. factory addition.

Windsor, Ont.—The Kerr Engine Works, Walkerville, have been awarded the contract by the city council for 50 brass water main valves.

Edmonton, Alta.—The city has awarded to the Packard Electrical Co., St. Catharines, Ont., the contract for four three-phase transformers at \$9,520.

Fort William, Ont.—The city has awarded contracts for lead pipe and pig lead to the Northern Engineering Co. and W. S. Piper, the lowest tenderers.

St. Thomas, Ont.—Albert E. Ponsford, 605 Talbot Street, has secured the contract for building the plant of the St. Thomas Brass Co., costing \$25,000.

Medicine Hat, Alta.—The Western Sales Co., of Winnipeg, has been awarded a contract to instal a water system at a cost of \$50,000, for the Dunmore Development Co.

McAdam Junction, N.B.—The contract for building the new C. P. R. shops has been awarded to Henry Post, Woodstock, N.B. The shops will be operated by electric power.

Outremont, Que.—The city council have awarded the contract for a system of underground conduits to G. M. Guest for \$98,000, turning down the lowest tender by Deitrich, Ltd., for \$81,000.

Montreal, Que.—The Robt. Mitchell Co., Belair Avenue, have awarded the contract for building an iron foundry to the James Shearer Co., 225 St. Patrick Street. The foundry will measure 108 x 180, and be one storey high.

Ottawa, Ont.—The contract for the construction of the Morrisburg and Ottawa Railway has been awarded to the Reliance Contract Co., of Chicago. The Ontario Hydro-Electric Commission is under bond to supply power for the road.

Goderich, Ont.—Bennet and Wright, of Toronto, have a contract from the Western Canada Flour Mills for installing a sprinkler system in the mills. The water will be supplied from a concrete reservoir, 40 x 40 x 14 ft., holding 1,000,000 gallons.

Montreal, Que.—The contract for the enlargement of the Montreal city aqueduct has been awarded to the Cook Construction Co., of Sudbury, for \$2,322,562. The company has headquarters in Canada at Sudbury, and in the United States at St. Paul, Minn.

Sault Ste. Marie, Ont.—The H. E. Talbot Construction Co. has been awarded the contract for the construction of the power dam, power house and paper making plant of the Donnacona Paper Co. at Donnacona. The contract amounts to \$300,000.

Regina, Sask.—The Council has awarded the following contracts for sidewalks, sewer and water mains: Bitulithic Contracting and Paving Co., 72,093 yards paving, \$216,297; The National Pavers, 69,771 yards asphalt paving, \$193,847; The Regina Foundry Co., 250 manhole covers and fittings, \$4,250. Sewer extension contracts went to R. J. Lecky & Co., H. G. McVean, John Brodt, and Sykes Co., of Neepeawa.

Tenders

Sherbrooke, Que.—The Gas and Electric Department have been authorized to ask tenders for a motor truck.

Saskatoon, Sask.—Tenders for a \$350,000 bridge will be called for shortly, and it is understood there will be keep competition among Western firms for the job.

Toronto, Ont.—Tenders will be received by the undersigned till June 20, in bulk or separately, for the following departments in connection with the Hudson's Bay Co. departmental store, Vancouver, B. C.:—Steam-fitting, electric wiring, plumbing, refrigeration, vacuum cleaning, sprinklers, steam-driven generating units, turbine generating units, steel smoke stack, suction ash conveyor, pneumatic cash tubes. Burke, Horwood & White, architects, 28 Toronto St., Toronto.

Marine

Port Coquitlam, B.C.—The Coquitlam Shipbuilding and Marine Railway Co. will build a marine railway slip, costing \$30,000. L. D. Shafner is manager.

Port Coquitlam, B. C.—The Fraser River Navigation Co. will put on a freighter to make daily trips between this city and New Westminster, and will erect a wharf at Pitt River.

Toronto, Ont.—The Richelieu and Ontario Navigation Co. have bought out the following five lines:—The Canadian Interlake Line, Limited, The Niagara Navigation Co., The Inland Lines, Ltd., The Ontario & Quebec Navigation Co., The Quebec Steamship Co.

Vancouver, B. C.—The Northern Dredging Co. Ltd., capital \$250,000 has been incorporated at Victoria to do dredging work on the coast of the mainland, and Vancouver Island. They have one dredge of the dipper type, and are making arrangements for two others as soon as contracts are signed up. Their offices are in the North-West Trust Bldg. J. A. McDougall, is president and general manager, and W. B. Brien, vice-pres, and treas.

Refrigeration

Nanaimo, B.C.—Quesnell & Son are installing a 5-ton refrigerating plant, furnished by the Armstrong Machinery Co., Spokane, Wash.

Coquitlam, B.C.—The Mt. Coquitlam Asylum is being equipped with a 25-ton refrigerating machine, furnished by the York Co., York, Pa.

Vancouver, B.C.—The Turner Dairy is installing a 5-ton refrigerating plant, supplied by the Armstrong Machinery Co., Spokane, Wash.

Calgary, Alta.—The P. Burns Co., Ltd., meat packer, contemplate building an abattoir and cold storage plant at South Fort George, B.C.

London, Ont.—The London Sanitarium has installed a 2-ton "York" vertical, single-acting refrigerating machine, by the Kent Co., Montreal.

Vancouver, B.C.—The Valley Dairy are installing a 5-ton refrigerating plant, furnished by the Armstrong Machinery Co., Spokane, Wash.

Cranbrook, B.C.—The 41 Market Co. have awarded the Armstrong Machinery Co., Spokane, Wash., for installation a 5-ton Alaskan refrigerating machine.

Toronto, Ont.—The Paterson Candy Co. are having their candy factory equipped with a 17-ton refrigerating machine furnished by the York Co., York, Pa.

Montreal, Que.—The Engineers' Club has installed in its club house a 4-ton

"York" refrigerating machine and 1¼-inch direct expansion piping. The Kent Co., Montreal, were the contractors.

Vaudreuil, Que.—The Canadian Explosives Co., of Montreal, is having its dynamite factory equipped with a 30-ton vertical refrigerating machine, furnished by the Frick Co., Waynesboro, Pa.

Fredericton, N.B.—Searle & Lamson, Ltd., plan the erection of a refrigerating and cold-storage plant, to cost about \$50,000. The building will be 90 x 30 ft., and of concrete construction throughout.

Toronto, Ont.—S. Caulfield & Sons, dairymen, have installed a 6-ton refrigerating machine, with 1¼-inch direct expansion piping, for cold storage rooms. The York Co., York, Pa., supplied the machinery.

Toronto, Ont.—The new municipal abattoir and cold storage plant now being erected at Toronto, Ont., Canada, is to cost about \$350,000. Wm. R. Perin & Co., abattoir engineers, Chicago, Ill., made the plans, and will supervise the erection.

Saskatoon, Sask.—The Saskatchewan Abattoirs, Ltd., capital \$200,000, plan the erection of an abattoir and cold storage plant, also a soap factory, two storeys high, measuring 150 x 50 ft. W. C. Smith, president of the Standard Soap Mfg. Co., St. John's, Nfld. is interested. The cold storage plant will cost \$100,000.

Arctic Ice Machine Co.—The Arctic Ice Machine Co., Canton, O., have opened new Western offices for the purpose of covering the States of Utah, Idaho and Nevada. The new offices are located at No. 1114 Newhouse Building, Salt Lake City, Utah, and at 1329 25th Street, Ogden, Utah and will be in charge of H. H. Keener who is a practical experienced ice machine man and has already erected a number of Arctic plants for his customers in the territory named. The Arctic Ice Machine Co. further announces that they have made arrangement whereby their interests in and about Philadelphia, Pa., will be handled by John H. Gold at 1550 N. 62nd Street, Philadelphia. Mr. Gold is an experienced refrigerating engineer.

Obituary

Amable Relanger, proprietor of the Montmagny Foundry, died May 29, in St. Lue Hospital, following an operation for appendicitis. He was 35 years old.

Trade Gossip

Aurora, Ont.—The Positive Clutch & Pulley Works has shipped to Bobcaygeon for the hydro-electric system a pulley 135 inches in diameter and a 20-inch face.

The Nova Scotia Steel & Coal Co., made a record for May with a production of 73,450 tons of coal, 79,540 tons of pig iron, 5,855 tons of steel ingots, 37,804 tons of ore, and product of finishing mills, 6,665 tons.

The Hill-Brunner Foundry Supply Co., of Cincinnati, is comprised of Mr. John Hill, and Mr. Fred J. Brunner, neither of whom need personal introductions to the trade, each having been identified with the foundry business, and combining an experience of over fifty years in that line. We are informed that they are operating very large, modern, up-to-date plants at Cincinnati, Ohio, and Chattanooga, Tenn., and have a branch warehouse at Birmingham, Ala.

Miscellaneous

Tilbury, Ont.—The town has granted a loan of \$10,000 to the Canada Forging Co., who will build a plant here.

Victoria, B.C.—The C.P.R. will be in the market for an air compressor and machine tool equipment for repair shops to be built on the wharf here.

Aylmer, Ont.—The Central Pipe Line Co., Ltd., have taken over the franchise of the Peninsula Oil and Gas Co., Ltd., and will instal a larger gas pipe line.

Waterloo, Ont.—The Quality Mattress Co. of Berlin, Ont., have asked the Town Council for \$10,000 to aid them in erecting a factory in Waterloo.

New Westminster, B.C.—Tenders have been called by the city for the completion of the first unit of the jetty works at the Sandheads, the cost of which is estimated at \$100,000.

The Bennett & Wright Co., of Toronto, Ltd., have changed their corporate name to The Bennett & Wright Co., Ltd., increasing the capital stock from \$98,000 to \$300,000.

British Trade.—The May statement of the Board of Trade shows increases of \$31,056,000 in imports, and \$25,128,000 in exports. The principal import increase was in raw material, and in exports of manufactured goods, of which cotton textiles gained \$5,000,000.

Tilbury, Ont.—Tilbury town ratepayers voted on two by-laws, one to grant a loan of \$10,000, repayable in ten years, to the Canadian Forging Co., and the

other to raise \$5,000 to build a fire hall. The Forge Co. by-law was carried by 182 to 5 and the fire hall by-law by 114 to 66.

Montreal, Que.—The Armstrong-Whitworth Co., Newcastle-on-Tyne, England, are behind the project to build a new steel plant at Longueuil, near Montreal, the land for which has been purchased. M. J. Butler, formerly of the Dominion Steel Co., is to be the head of the new concern. Sir Percy Girouard arranged for this plant on a recent visit to Canada.

Prince Albert, Sask.—Tenders for the following water pipe will be received by C. O. Davidson, city clerk, until June 12: Contract (A), approximately, 2,520 lin. ft. 10 in. cast iron water pipe; 21,700 lin. ft. 8 in. cast iron water pipe; 26,300 lin. ft. 6 in. cast iron water pipe; 43,000 lbs. special castings. Contract (B), 7-10 in. gate valves; 63-8 in. gate valves; 67-6 in. gate valves.

Fort William, Ont.—Contracts have been let by the Steel Co. of Canada for the erection of a wire nail manufacturing plant, costing over \$300,000; Praek and Perrine, engineers, of Toronto and Hamilton, have charge of the work. The buildings will be of brick and steel construction, with cement roofs, one storey high. The three mills will measure respectively 250 x 50 ft., 150 x 100 ft., and 125 x 100 ft. The warehouse will be 175 x 75 ft., of two storeys, and the power house 175 x 75 ft., one storey. A local company will get the contract for a dock 50 ft. deep, with 250 frontage.

Catalogues

The Standard Oil Co. (California), from their department of Asphaltum, have issued Bulletin No. 5, entitled, "Scientific Road Construction," which comes at a time when many of towns in Canada are considering the making of good roads. After an introduction dealing with the subject in general, the article gets down to materials, with methods of making and laying. Photographs are used to illustrate.

"The Blow-off" is the title of a breezy magazine published by Yarnall-Waring Co., Chestnut Hill, Philadelphia, Pa., makers of Simplex-Caskey Valves for hydraulic service, and the Simplex pipe-joint clamp. The Nelson Valve Co., of the same address, make "Nelson" valves. This magazine, of course, tells much about this firm's valves, etc., but it also contains lots of general interesting matter, even giving a page to jokes, and another to "Little Thoughts on Big Problems."

"Our Old Friend in a New Light" is the calendar intimation received of the absorption by the Canadian Allis-Chal-

mers Co., Ltd., of the Allis-Chalmers-Bullock Co., Ltd., Montreal, Toronto, Winnipeg, Vancouver, etc. A beaver colony at work, entitled "The First Engineers," has furnished the pictorial feature of the latter company's calendar for a number of years back, and in the present instance, the glow from a forest fire shows the industrious animals in a "New Light," without doubt. The new organization is to be commended for the enterprise shown in preparing such an effective announcement.

The Stark Rolling Mill Co., Canton, Ohio, have sent us their latest catalogue describing their Toncan Metal Products. This "Text Book on Corrosion" as it is called, is divided into three sections, the first or technical being a description of Toncan Metal, and explaining its non-corrosive properties. The second section contains a number of illustrations of building and other places where Toncan Metal Products have been used. The third section contains particulars of the products into which Toncan Metal is made, such as flat and corrugated sheets, pipe, etc. This section also contains some valuable tables and information on roofing, etc.

The Acme Stamping and Tool Co., 34 Sydney St., Hamilton, Ont., who make water motors for washing machines, and other special machinery, recently built a brass foundry at their plant, in which to manufacture brass castings used in connection with water motors, etc. The new building measures approximately 30 x 40 ft. Among other equipment, they purchased two gas furnaces, having hoods connecting with the chimneys to carry away the fumes from the brass. A feature about these hoods is that they will telescope, and push out of the way when not required. The furnaces are fired by natural gas, supplied by a Hamilton concern.

The Cleveland Pneumatic Tool Co., of Canada, Ltd., Toronto, Ont. deserve credit for producing Catalogue 12, dealing with pneumatic tools of every description. It is their twelfth annual catalogue, and contains valuable information for machinists, boilermakers and foundrymen. We often go into shops and find men plugging away with hammer and chisel at work that could be performed in a fraction of the time with a pneumatic tool. Firms who have not compressed air on their plant, and have never thought of having it, should write to the above firm for reasons why they should have it; they will be surprised at the large number of ways in which they can save money. Catalogue 12 should be sent for anyhow, as a treatise on how to do things right.

The Osborn Manufacturing Co., Cleveland, New York, Milwaukee and San

Francisco, makers of moulding machines, send us catalogue No. 142, bearing their amusing trade mark of an ape carrying a crucible of metal. On the frontispiece is a picture of a variety of light gray iron castings turned out by one concern on certain types of Osborn machines. What other work may be done by machine is indicated by photographs scattered throughout the book, showing foundry floors with work finished or in process. The Osborn Mfg. Co., however, are ready to build machines to meet the needs of foundrymen who have special problems to face. The catalogue, which will be willingly sent to those interested, is lavishly got up, and should be kept handy for reference.

Federal Graphite.—We have received an interesting pamphlet from the Federal Graphite Mills, Cleveland, Ohio, entitled "Actual Experiences of Engineers with Boiler Graphite." This material is a specially prepared graphite for the prevention and removal of scale from steam boilers. It is mechanical rather than chemical in action. The Boiler Graphite, it is claimed, on entering the boiler and coming in contact with the scale forming properties in the water prevents them from adhering to the metal, forming a sludge which is deposited on the bottom of boiler and easily removable. With existing scale, the finely powdered graphite eats its way into the small cracks in the scale, weakens it and destroys its adhesion to the boiler plates and tubes. The graphite is mixed with water and fed into the suction pipe of the feed pump. Being mechanical in action it can be used with any kind of feed water. A copy of the pamphlet will be gladly sent on request.

The Mesta Machine Co., Pittsburgh, Pa., have introduced a new valve (Iverson Patent), which they are fitting to their blowing engines and air compressors. The valve is automatic and of the multi-posted plate type. There are no flash ports and no large clearance spaces. The valve needs no attention and no oiling, and consists of a thin annular steel plate which is guided without friction by a volute spring; the latter furnishing at the same time the small force which is necessary to start the closing motion of the valve, an engine can be operated at 80 R.P.M. instead of 40 R.P.M., which is about the average speed of Blowing Engines. The steam end is not only more economical, but the engine has twice the capacity. The following are the principal advantages claimed for this valve. Simplicity of air end; no valve gear required; greater volumetric and mechanical efficiency; no wear; practically no repairs; no lubrication; practically no attendance; noiseless operation up to the highest speed, and reliable and economical up to 100 R.P.M.

Book Reviews

"Kinks." In *Patent Law and Practice* is the title of an interesting little pamphlet which we have received from the Detroit Patent Bureau. It contains some valuable information for those who are considering taking out Patents. The present is the 2nd edition.

"Worm Gearing," by Hugh Kerr Thomas, A.M.D.M.E., 84 pages, 6x9 inches, 33 illustrations and diagram. Published by the McGraw-Hill Book Co., New York and London. Price, \$1.50 net. This is a very exhaustive work on the subject of worm gears. The principles involved in the design of worm gearing are fully described, especially with regard to its application to automobile rear axles, as a more efficient method of driving than with bevel gears. The data given is for the most part original, and obtained from experiments. The subject although complicated has been, by the use of elementary mathematics, treated as simply as possible.

The Steam Consumption of Locomotive Engines From the Indicator Diagrams, by J. Paul Clayton, has been issued as Bulletin No. 65 by the Engineering Experiment Station of the University of Illinois. This Bulletin develops and illustrates the application of the logarithmic diagram to locomotive engines, and it is shown that the steam consumption can be determined from the indicator diagrams alone, to within 4 per cent. of the actual consumption as measured in test plants. Copies of Bulletin No. 65 may be obtained upon application to W. F. M. Goss, Director of the Engineering Experiment Station, University of Illinois, Urbana, Illinois.

"American Machinist Grinding Book" by Fred. H. Calvin and Frank A. Stanley. 376 pages, 332 illustrations and tables. Published by the McGraw-Hill Book Co. New York City. Price \$3.00 net. This is a new treatise on grinding and contains a lot of valuable information on the subject. The authors are both authorities on machine shop practice, and have written this book from a thoroughly practical standpoint, some data having been taken from the columns of "American Machinist." Grinding is treated in all its phases, different types of machines are illustrated, and various operations described fully. The book contains 36 tables, full of interesting data for the shop, and two chapters are devoted to grinding wheels, degrees of hardness necessary for various classes of work, different shapes, etc. Several processes are described where grinding has taken the place of milling with better results. The book is thoroughly up-

to-date and should be in the hands of all purchasing agents and operators.

SPECIAL WORK IN SHOP SAFETY AND SANITATION.

IN a recent issue of *American Industries* there appears an article by Dr. Francis D. Patterson, director of the department of sanitation and accident prevention, of Harrison Bros. & Co., Inc., Philadelphia, dealing with "Sanitation and Safety in Heavy Chemical Production." Much of the work done at this plant in the interest of employees is typical of what the leaders in the safety and sanitation campaigns in various industries are carrying on; very much of it also is special, in view of the dry grinding of lead and other operations which require precautions for the guarding of health.

All applicants for employment are given a physical examination, and in this way those who present evidences of a physical defect which impairs their health, and makes them more liable to an accident, are barred from employment. Every effort is made to maintain employees in good health by the provision of properly lit and ventilated rooms, and when ill they are urged to consult the medical director, on the company's time, without charge, with the result that many ailments, which might become more serious, are cured without loss of time. Every accident is investigated, not only with the object of determining why it happened, but so that the necessary measures may be taken to prevent an accident from a similar cause occurring again. Special facts in connection with any accident and general remarks on the subject of safety are brought to the attention of all employees by being printed and placed on the 48 safety bulletin boards, which are located in prominent positions.

What has been accomplished is indicated by the decrease in the number of accidents. In the month of October, or the month previous to the beginning of the campaign, there were 44 accidents; in November, 36 accidents, a decrease of 18.1 per cent.; in December, 28 accidents, a decrease of 18.1 per cent. from the previous month and a decrease of 36.2 per cent. from October. In January, there were 21 accidents, a decrease of 15.9 per cent. from the previous month, or a total decrease of 52.1 per cent.—*Iron Age.*

CALLING PEOPLE DOWN.

THE old idea still persists in the world that it is necessary to "call people down" occasionally in order to keep them in line. We find it surviving in every walk of life, from domestic service, through all the various lines of in-

dustry, and even into the realm of friendship. Nagging domestic servants has been the greatest cause of a "servant problem," and calling employees down about the most trivial things is the chief reason why there is not more loyalty shown by employees towards employers. You cannot expect loyalty from a man whom you insult continually. If you ill-treat him he will ill-treat you. It is all a matter of reaction and inexorable law. If you act towards your employees in a disagreeable manner, they must of necessity react towards you in the same way.

Our actions are all merely responses to stimuli. The employee is a part of the environment of the employer, and the employer constitutes a mighty important part of the environment of the employee. It may be laid down as a universal law of life that all the actions of men are nothing more nor less than a matter of reacting against the pressure of environment. This is a physical and inexorable law; there is no escape from it. The employer being, then, such an important part of the environment of the employee, and the actions of the employee being determined by his environment, how can the employer logically expect the employee to react towards him in a friendly and loyal way when the former does not handle the latter in the same manner?

You will get in this world just what you give. If you live by the sword, you will die by the sword. Action and reaction are equal and opposite in direction. To have friends, you must be one. You cannot cuss a man out, and "call him down" continually, and expect to get the best service from him. By all the laws of his being he must treat you as you treat him. Anyone who expects anything else from the average man is hopelessly behind the times in his ideas, and grossly ignorant of the laws of biology and psychology. Such a man needs to square himself and his antediluvian philosophy with modern science. He is trying to live in the twentieth century by the rules of the man of the stone age.—*Can. Industrial Review.*

NEW CANADIAN STEEL CO.

It is believed that a new steel company is to be located at Longueuil, across the river from Montreal. The land has already been purchased, and the plant to be erected will be one of the largest and best equipped in the country. M. J. Butler, formerly of the Dominion Steel Co., is to be at the head of the new concern, and Armstrong, Whitworth & Co., the famous British shipbuilders and gun manufacturers, are back of the project. It was to arrange the plant that Sir Percy Girouard visited Canada a short time ago.

SELECTED MARKET QUOTATIONS

Being a record of prices current on raw and finished material entering into the manufacture of mechanical and general engineering products.

PIG IRON.

	Per Ton.	
Foundry No. 1 and 2, f.o.b., Midland	\$19 00	\$19 50
Gray Forge, Pittsburgh	16	15
Lake Superior, charcoal, Chicago	18	00
	Mont'l.	Tor'to.
Canadian f'dry, No. 1.	\$21 00	\$20 00
Canadian f'dry, No. 2.	20 50	19 50
Middlesboro, No. 3.	23 50	23 50
Summerlee, No. 2	25 00	26 50
Carron, special	25 00
Carron, soft	25 00
Cleveland, No. 1	24 25	25 00
Clarence, No. 3	23 75	24 50
Jarrow	25 50
Glengarnock	26 00
Radnor, charcoal iron.	30 00	34 50
Ferro Nickel pig iron (Soo)	25 00

BILLETS.

	Per Gross Ton.	
Bessemer billets, Pittsburgh	\$28 50	
Open hearth billets, Pittsburgh.	29 00	
Forging billets, Pittsburgh.	36 00	
Wire rods, Pittsburgh	30 00	

FINISHED IRON AND STEEL.

Per pound to large buyers:

	Cents.
Common bar iron, f.o.b., Toronto	2.10
Steel bars, f.o.b., Toronto	2.20
Common bar iron, f.o.b., Montreal	2.15
Steel bars, f.o.b., Montreal	2.25
Bessemer rails, heavy, at mill	1.25
Iron bars, Pittsburgh	1.70
Steel bars, Pittsburgh, future	1.40
Tank plates, Pittsburgh, future	1.45
Beams, Pittsburgh, future	1.45
Angles, Pittsburgh, future	1.45
Steel hoops, Pittsburgh	1.60

Toronto Warehouse f.o.b., Toronto.

	Cents.
Steel bars	2.30
Small shapes	2.45

Warehouse import, freight and duty to pay:	Cents
Steel bars	1.95
Structural shapes	2.05
Plates	2.05

Freight, Pittsburgh to Toronto:

18 cents carload; 21 cents less carload.

BOILER PLATES.

	Mont'l.	Tor'to.
Plates, ¼ to ½-in., 100 lbs.	\$2.35	\$2.35
Heads, per 100 lbs.	2.65	2.95
Tank plates, 3-16 in.	2.60	2.60
Tubes, per 100 ft., 1 inch	9.00	8.50
" " 1¼ in.	9.00	8.50
" " 1½ "	9.00	9.00
" " 1¾ "	9.00	9.00
" " 2 "	8.75	8.75
" " 2½ "	11.50	11.50
" " 3 "	12.00	12.00
" " 3¼ "	13.75	13.75
" " 3½ "	14.50	14.50
" " 4 "	18.00	18.00

BOLTS, NUTS AND SCREWS.

	Per cent.
Stove bolts	80 & 7½
Machine bolts, ¾ and less	65 & 5
Machine bolts, 7-16.	57½
Blank bolts	57½
Bolt ends	57½
Machine screws, iron, brass	35 p c.
Nuts, square, all sizes	4c per lb off
Nuts, Hexagon, all sizes.	4¼ per lb off
Flat and round head.	35 per cent.
Fillister head	25 per cent.
Iron rivets	60, 10, -0 off
Wood screws, flathead, bright	85, 10 p c off
Wood screws, flathead, brass	75, 10 p c off
Wood screws, flathead bronze	70, 10 p c off

National-Acme "Milled Products."

Sq. & Hex Head Cap Screws	65 & 10%
Sq. & Hex Head Cay Screws	65 & 10%
Rd. & Fil. Head Cap Screws	45-10-10%
Flat & But. Head Cap Screws	40-10-10%
Finished Nuts up to 1 in.	75%
Finished Nuts over 1 in.	72%
Semi-Fin. Nuts, up to 1 in.	75%
Semi-Fin. Nuts over 1 in.	72%
Studs	65%
Discounts f.o.b., Montreal.	

WROUGHT IRON PIPE.

The following are Toronto jobbers' discounts on pipe in effect from April 21, 1913:

	Buttweld		Lapweld	
	Black	Gal.	Black	Gal.
¼ ¾ in.	62	47
½ in.	68	58
¾ to 1½	71½	61½	68½	58½
2 in.	71½	61½	68½	58½
2½ to 4 in.	71½	61½	70½	60½
4½ to 6 in.	71½	61½
7, 8, 10 in.	66	54

X Strong P. E.

¼, ⅜, ½ in.	56½	46½
¾ to 1½ in.	67½	57½
2 to 3 in.	68½	58½
2½ to 4 in.	65	55
4½ to 6 in.	64	56
7 to 8 in.	55	45

XX Strong P. E.

½ to 2 in.	43	33
2½ to 4 in.	43	33

PRICES OF WROUGHT IRON PIPE.

Standard. Nom. Diam.	Price. per ft.	Extra Strong.		D. Ex. Strong.	
		Size Ins.	Price per ft.	Size Ins.	Price per ft.
½ in.	\$.05½	½ in.	\$.12	½ in.	\$.32
¾ in.	.06	¾ in.	.07½	¾ in.	.35
¾ in.	.06	¾ in.	.07½	1 in.	.37
1 in.	.08½	1 in.	.11	1¼ in.	.52½
1 in.	.11½	¾ in.	.15	1½ in.	.65
1 in.	.17½	1 in.	.22	2 in.	.91
1¼ in.	.23½	1¼ in.	.30	2½ in.	1.37
1½ in.	.27½	1½ in.	.36½	3 in.	1.86
2 in.	.37	2 in.	.50½	3½ in.	2.30
2½ in.	.58½	2½ in.	.77	4 in.	2.76
3 in.	.76½	3 in.	1.03	4½ in.	3.26
3½ in.	.92	3½ in.	1.25	5 in.	3.86
4 in.	1.09	4 in.	1.50	6 in.	5.32
4½ in.	1.27	4½ in.	1.80	7 in.	6.35
5 in.	1.48	5 in.	2.08	8 in.	7.25
6 in.	1.92	6 in.	2.86
7 in.	2.38	7 in.	3.81
8 in.	2.50	8 in.	4.34
8 in.	2.88	9 in.	4.90
9 in.	3.45	10 in.	5.48
10 in.	3.20
10 in.	3.50
10 in.	4.12

IRON PIPE FITTINGS.

Canadian malleable, 40 per cent.; cast iron, 65; standard bushings, 70; headers, 60; flanged unions, 65; malleable bushings, 65; nipples, 75; malleable, lipped unions, 65.

COKE AND COAL.

Solvay Foundry Coke	5.95
Connellsville Foundry Coke	5.45
Yough, Steam Lump Coal	3.83
Penn. Steam Lump Coal	3.63
Best Slack	2.95
All net ton f.o.b. Toronto.	

OLD MATERIAL.

	Tor'to.	Mont'l.
Copper, light	\$12 05	\$11 00
Copper, crucible	15 00	13 50
Copper, uncre'bled, heavy	13 05	12 50
Copper wire, uncre'bled..	13 05	12 50
No. 1 machine compos'n..	12 00	11 00
No. 1 comp's'n turnings..	10 00	10 00
New brass clippings	9 00	9 00
No. 1 brass turnings	8 30	7 75
Heavy lead	3 40	3 75
Tea lead	3 00	3 00
Scrap zinc	4 00	3 75
Dealers' purchasing prices.		

METALS.

Prices in cents per pound:

	Mont'l.	Tor'to.
Lake copper	16.00	16.00
Electrolytic copper	16.00	16.00
Spelter	6.00	5.75
Lead	4.70	5.05
Tin	50.00	49.50
Antimony	10.00	9.75
Aluminum	21.00	20.00

SMOOTH STEEL WIRE.

No. 6-9 gauge, \$2.35 base; No. 10 gauge, 6c extra; No. 11 gauge, 12 extra;

No. 12 gauge, 20c extra; No. 13 gauge, 30c extra; No. 14 gauge, 40c extra; No. 15 gauge, 55c extra; No. 16 gauge, 70c extra. Add 60c for coppering and \$2 for tinning.

Extra net per 100 lb.—Spring wire; bright soft drawn, 15c; charcoal (extra quality), \$1.25.

SHEETS.

	Mont'l.	Tor'to.
Sheets, black, No. 28....	\$2 85	\$3 00
Canada plates, ordinary, 52 sheets	2 80	3 00
Canada plates, all bright.	3 70	4 15
Apollo brand, 10¾ oz. (American)	4 30	4 20
Queen's Head, 28 B.W.G..	4 50
Fleur-de-Lis, 28 B.W.G..	4 20
Gorbal's Best Best, No. 28	4 45
Viking Metal, No. 28....	4 40

NAILS AND SPIKES.

Standard steel wire nails, base	\$2 40
Cut nails	\$2 60	2 65
Miscellaneous wire nails..	75 per cent.	
Pressed spikes, 5/8 diam., 100 lbs.	2 85

FINE STEEL WIRE.

Discount 25 per cent. List of extras. In 100-lb. lots: No. 17, \$5; No. 18, \$5.50; No. 19, \$6; No. 20, \$6.65; No. 21, \$7; No. 22, \$7.30; No. 23, \$7.65; No. 24, \$8; No. 25, \$9; No. 26, \$9.50; No. 27, \$10; No. 28, \$11; No. 29, \$12; No. 30, \$13; No. 31, \$14; No. 32, \$15; No. 33, \$16; No. 34, \$17. Extras net. Tinned wire, Nos. 17-25, \$2; Nos. 26-31, \$4; Nos. 30-34, \$6. Coppered, 75c; oiling, 10c.

MISCELLANEOUS.

	Cents
Putty, 100 lb drums	\$2.70
Red dry lead, 560 lb. casks, per cwt.	6.00
Glue, French medal, per lb	0.10
Glue, 100 flake	0.11
Tarred slaters' paper, per roll...	0.95
Motor gasoline, single bbls., gal..	24½
Benzine, per gal.	23½
Pure turpentine	64
Linseed oil, raw	58
Linseed oil, boiled	61
Plaster of Paris, per bbl.	2.10
Plumbers' Oakum, per 100 lbs....	3.25
Pure Manila rope	17

The General Market Conditions and Tendencies

This section sets forth the views and observations of men qualified to judge the outlook and with whom we are in close touch through provincial correspondents.

Montreal, June 10, 1913.—No definite statement can be obtained as to the situation in machine tool circles. Dulness with buoyancy is still the slogan, but "what does this mean?" The only answer is that many estimates are out, and they are all said to be "coming," but tight money knocks them for the

moment. A chat with any of the big dealers is enough, however, to inspire one with faith in the prosperity that is like a hidden volcano in our midst. The genius behind it all is just what these good selling people practice—"keeping a stiff upper lip." One strong man said: "Wait until the end of July, then you'll

see some loosening up in machine tools." This man knows. The Dominion Steel Corporation have held their annual meeting and the big Westinghouse order which was floating around a couple of weeks ago for 15,000 tons of foundry iron has been cut in two because the price was too high.

Pig Iron, Coke & Copper.

There have been some large orders placed here and in the district for pig iron, owing to some concessions in price which are unquotable. Still, there is not the activity. Best prophets state that,

JAMES R. CAMERON, M. E., Manager PHONE NORTH 5831

THE PATENT SELLING & MFG. AGENCY



PATENT EXPERTS—MECHANICAL ENGINEERS

Patents Caveats Trade-marks Copyrights Designs Procured	Patents Obtained Sold Developed and Manufactured on Royalty	Inventions Perfected Marketed Protected Handled and Developed	Searches Extensions Licenses Assignments Agreements Renewals	Working Drawings Dies and Tools Patterns Estimates Given on Rights and Manufacturing Costs.
--	--	--	---	--

WRITE FOR PRICES AND TERMS. Address: SUITE 301-302, 22 COLLEGE STREET, TORONTO, ONT.

Plant of The National Steel Car Co., Ltd., Hamilton, Ont.

Staff Article

The growth and development of railroad systems in Canada are so rapid and insistent, that established factories for the production of the necessary equipment and rolling stock, are not only found, at brief intervals to be too small to cope with the requirements, but, in addition, are too few in number, and in some cases not quite central enough. The National Steel Car Co., Ltd., of Hamilton, owes its inception to the second cause.

THE National Steel Car Co., Ltd., was incorporated in July, 1912, under a Dominion charter, with head offices in the Transportation Building, Montreal. The authorized capital stock is \$6,000,000, and the paid-up capital, \$3,500,000. Before the plant was completed, an order for 1,500 box cars was received, and other large orders have been received since.

Buildings Layout.

The plant proper consists of two large buildings, the main shop at the north, and the paint shop on the south. Besides these, there are the offices, which stand alone to the east, and the power house, which is adjacent to the main shop, and receives a portion of its fuel from the wood-working department. The steel structural work was supplied and erected by the McClintock-Marshall Construction Co., Pottstown, Pa., and

the buildings are of that company's standard monitor type of construction. For a height of eight feet above ground level, the walls are of National Fire-proofing Co. hollow tile construction, and above this, they are fitted with Lupton continuous steel sash.

The main building is divided into three bays, two of 75 feet and one of 50 feet. The fifty-foot bay consists of forge shop and machine shop, truck shop, tool room and pipe shop; these departments following one another in the order named, the forge shop being next the stock yard. The centre bay is 75 feet wide, and consists of punch and shear shop, construction department and steel car erecting shop. The other 75 feet bay is on the west side and forms a planing mill and wood car erecting shop. The cars pass through the various stages of construction in this shop, and afterwards proceed to the paint shop, which is 300

feet south of the main shop, and has accommodation for sixty cars. It measures 250 x 144 ft., and has ten tracks which are served from the main shop by a transfer table. The first car was turned out in the middle of December, 1912, and the first shipment was made in January of this year. The works are turning out at present about 350 to 400 cars a month, but the output is continually increasing, being at the rate of eight or ten cars a week. When things are in full swing, 1,300 men will be employed. Additional buildings, equipped with electric and oxy-acetylene welders, and others laid out and equipped for up-to-date cabinet and interior finishing work of steel passenger and electric cars are projected for erection and completion before the end of the present year. The plant is served by switches from the T.H. & B Ry. and the G.T.R. The works being situated on the shore of the



CORNER OF TRUCK SHOP.

bay, the company intend to build a dock, and dredge the bay so as to enable them to handle raw stock by boat as well as by rail, should business justify it.

Yard Features.

At the back end of the shop, along the bay front, a stockyard runway has been erected for steel and lumber. It is served by a crane runway, 520 feet long, carrying a 10-ton traveller. Other materials are stored on the north and south sides of the shops, where there are also facilities for getting them into the latter, quickly. The yards on the north are used for storing castings, and other materials which do not deteriorate through exposure to the weather, and are served by a system of industrial railway tracks.

Car Construction.

On entering the main shop, one takes notice of the smoothness with which everything moves. The employes are making cars, and the process is continuous. Unlike a general shop where there are many side departments, one is able to trace at a glance the development of the completed car. After the trucks have been put together and placed on the rails, the main steel sills are placed across and bolted. In the second position, the holes are reamed out; then another move is made to the third position where the riveting is done; another move, and the sides and end frames are erected. In position No. 6 the corners are riveted, and in the seventh position, the trimmings are put on, and the steel work is complete. Thus, it will be seen that the cars are always on the move, and always in process of construction.

Tools and Equipment.

The characteristic of the tools used in this industry is seen by reference to the punches, shears and riveters shown in the accompanying illustrations. In the main erecting shop, oil fired furnaces for heating the rivets are conveniently located. There are seven portable riveters of the Vulcan Engineering & Sales Co. manufacture. With all these machines going, it will be readily imagined that the frames are soon secured in position. The cars are built on what is known as the "track" system.

Steel Preparation Department.

The first department to be considered relative to the building of steel cars is the steel preparation department. This shop is equipped with up-to-date machinery for converting steel into desirable shapes at the least possible cost. The shearing machinery runs from small 12-inch up to 120-inch blade shears. The punching machinery is of the latest type, and the large machines are equipped with automatic spacing tables operating



GENERAL VIEW OF PLANT OF NATIONAL STEEL CAR CO., HAMILTON, ONT.

to templet, which eliminates the human element, and at the same time assures absolute accuracy. There are quite a number of small punches and shears in the shop. One of the punches being a 48-inch multiple, and one a flanging punch with Thomas spacing table. There are also angle shears and various sizes of quick action punches, and a 120-inch multiple punching machine. The materials pass through the different machines from the steel yard towards the centre of the shop where erecting commences. The erection is carried forward in a straight line, so that by the time the end of the shop is reached, the steel work is completed, thus preventing confusion or accumulation of parts in the shop. This department is served by overhead traveling cranes, and in cases where heavy materials are handled, each machine is equipped with Sprague electric or air hoists. Quite a number of the shears used in this department are the product of the Long & Allstatter Co., Hamilton, Ohio. One of the multiple punches used in this work has a capacity of 32 holes, it and several other machines being supplied by the Hilles & Jones Co., Wilmington, Del. The same firm supplied a 120-inch shear for this department, which is direct connected to a 35 h.p. C.G.E. motor.

The Erecting Shop.

In the erecting shop, the car is built up from the truck to a stage where the woodwork is required. Work from the other departments is centred here, and things are gauged to such a nicety that there is no overlapping or waiting, the steel being on the spot ready for erection. This department is served by an overhead track craneway for handling material which craneway mounts a number of small cranes which carry 4-ton Sprague electric hoists for turning under-frames; they also carry a number of one-ton Sprague electric hoists for handling portable riveters. It is impossible to form an idea of how much labor is saved by the use of these hoists. They pick up sides of cars and place them in position, the workmen being only required to operate the portable riveter, and secure the parts of the car in place. There are, in this department, two 75-ton hydro-static riveting machines, and two deep gap riveting machines, served by electric trolley and hoist. The deep gap riveter is stationary, the pieces to be riveted being brought to it by means of the overhead trolley. The man who operates the trolley may also operate the riveter. He requires a helper to hold and guide the piece when riveting is taking place, but so excellently is everything arranged, that the operation is practically performed by one man. Connected with the

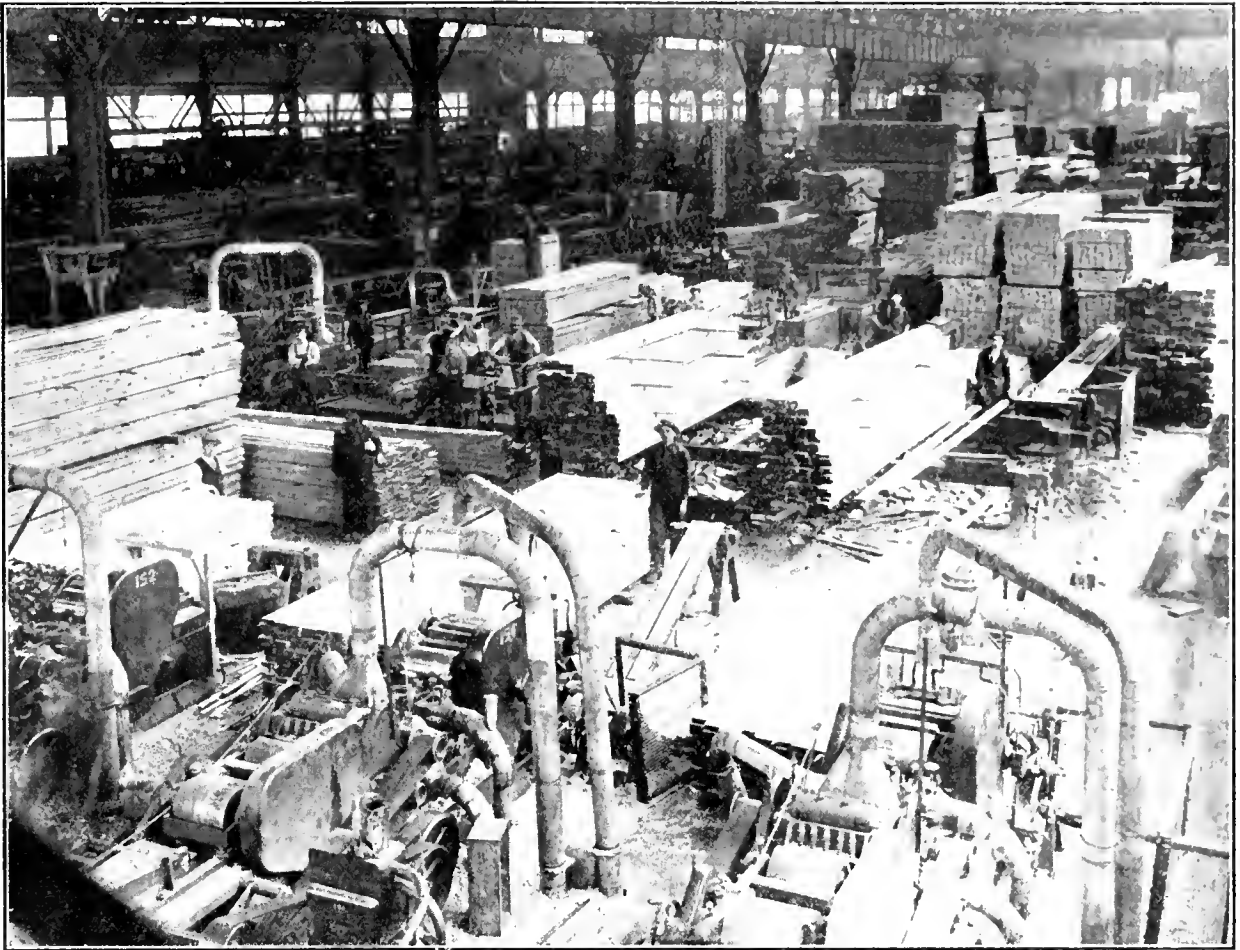

PLANING MILL DEPARTMENT.

main shop is a blacksmith shop measuring 50 x 120 feet, which is equipped in the most modern manner. It has three

bulldozers, Nos. 4, 6 and 8; 3 upsetting machines, 1½-inch to 4-inch; several power hammers, and continuous rivet-

ing machines with a capacity of 10,000 rivets a day, besides the usual smaller machines.

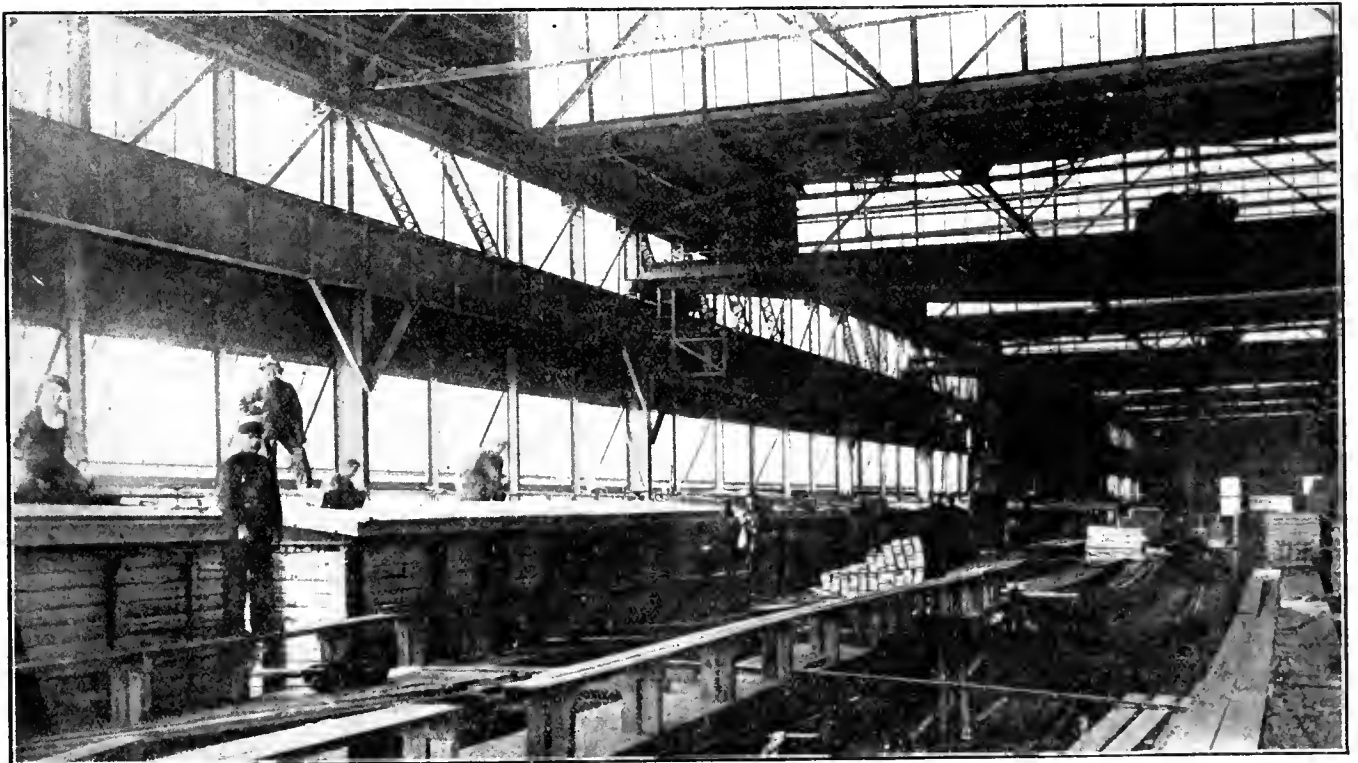

WOOD ERECTION DEPARTMENT.

Truck Shop.

The truck shop is fitted up in the usual manner with lathes, presses, drills, etc., provision being made for an extensive future enlargement. All the heavy

ders, and the carriers for levers are attached in steel erecting shop, while the rods and levers are usually put in place while the cars are standing in the paint shop.

applied to the cars both by hand and air spray, the firm, buying the paste, and preparing the paint themselves.

The air brakes are constructed at the Canadian Westinghouse Co. Works, Hamilton, while the firm make their own levers, rods, etc. It is their intention in future to build a foundry, in which they will manufacture quite a number of the parts at present being made elsewhere. Their idea was first to build cars, which they have succeeded in doing, and then undertake the provision of accessory equipment as occasion demands.

Power Plant.

On the west side of the main shop, 300 feet away, is situated the power house. This contains three 280 h.p. Erie City water tube boilers built by the John Inglis Co., Toronto; a Canadian Ingersoll-Rand steam-driven cross-compound Corliss, two-stage air compressor, which supplies power to all hand tools used throughout the shops, such as clipping hammers, rivet hammers, wood drills, etc. There is also a 1,000-gallon steam-driven Underwriters fire pump, which supplies water to the fire extinguishing system with which all the buildings are equipped. The pumps which supply the hydro-static pressure for riveters used in the shops, are operated here, being direct-connected to electric motors. There is also a motor generator set for supplying current to the hoists and craneways in the erecting shop. The



FORGE SHOP.

machines in this department are served by jib cranes or trolleys, and it is in this shop that the initial operation commences in connection with the car construction. The wheels for the car are brought in from the side of the building, as shown in the plan, and after the truck has been completed, it is pushed by hand, on rails, over to the erecting department, and then passes through its various stages of construction.

Paint Shop, Etc.

Three coats of paint are applied. After the first application, the car is allowed to stand for twenty-four hours

Woodworking Department.

The woodworking department is thoroughly up-to-date in every sense of the term. It occupies one of the 75 feet bays in the main shop, and consists of a planing mill and a wood car erecting shop. The machinery installed receives the lumber and converts it from the rough state, ready for use on the car. All the machines have individual motor drives, and are fitted with safety guards. The dust and shavings are removed by exhaust blowers and piping to the boiler house, where they are applied to steam-raising purposes. Adjacent to the boiler house is the silo. Several of the small wood-working machines were made by the Berlin Wood-Working Co., of Hamilton, Ont.

From the wood car erecting shop, the cars pass out into the yard, and while standing here waiting for admission to the paint shop, some of the smaller fittings are attached. The air brake cylin-

to permit the paint to dry. A second application is then made, after which the car stands for another twenty-four hours; the car being thus in the paint shop for a couple of days. The paint is

pumps for serving the oil furnaces used for heating rivets, etc., are also located in the power house. All the current used in this plant is alternating, with the exception of that used on the above



STEEL ERECTION DEPARTMENT.

craneways. As already stated, the fuel supplied to the boilers consists of saw-dust and shavings, supplemented by coal.

Power is supplied by the Cataract Power Co., and is stepped down from 10,000 to 220 volts, which is the voltage used throughout the shop. In the power house, there are four 150 k.w. transformers, manufactured by the Canadian Westinghouse Co., Ltd., Hamilton. All

At the end of the property, the tracks from the paint shop conveying the finished cars, converge into a single track and pass over a set of scales so that the cars may be weighed and stencilled with their proper weight.

The office building is located at the east side of the shops, and is two storeys in height, of brick construction. Here are the general offices of the company,

The following is a list of the directors:

Sir John Gibson, Toronto; Basil Magor, Hamilton; W. G. Ross, Montreal; Wm. Southam, Hamilton; J. J. Scott, Hamilton; W. K. Brice, New York; Wm. Barclay Parsons, New York; Sir Henry Pellatt, Toronto; Mortimer B. Davis, Montreal; M. H. Coggeshall, New York.

Mechanical engineer, E. C. McDowell, Hamilton; purchasing agent and assistant treasurer, A. Butze, Hamilton; W. E. Galloway, assistant purchasing agent, Hamilton; accountant, L. A. Rodger, Hamilton; C. R. Dillon, general foreman, Hamilton.



ELECTRIC MOTORS AND MICE.

THE insignificant mouse has, since the advent of electricity, played some rather curious pranks with electrical apparatus by his innocence of volts and amperes, and many a disastrous breakdown must, we fear, be put down to his inquisitiveness to explore the inner resources of electrical apparatus in his nocturnal rambles. It is not always possible to secure evidence of the part he has played in these matters, though he does occasionally pay for his temerity with his life and leave his electrocuted body as testimony to the role he has played. Motors in food purveying establishments are especially prone to receive his attentions, as we are reminded by a recent report of a Vulcan Co. surveyor respecting a visit to a motor of this kind in a butcher's shop. He remarks "it would be advisable to leave the cover off the motor, at least during the night, as, on examination, I found quite a lot of small pieces of meat inside the case which have been carried in by mice; the motor being covered in evidently made a good place for them to hide in."



The International Engineering Works, Ltd., Amherst, N.S., are building Robb water tube boilers for the Pietou County Electric Co., Stellarton, N.S.; the Ottawa Gas Co., Ottawa, Ont.; and the Inverness Railway and Coal Co., Inverness, N.S., while the Canadian Stewart Co., Montreal, have recently purchased 4 Robb-Brady Scotch boilers and one compressor.

The International Engineering Works, Ltd., Amherst, N.S., builders of Robb boilers and engines have recently sold horizontal return tubular boilers to the following companies:—The St. Lawrence Pulp and Lumber Co., Pabos Mills, P.Q.; the N. S. Clay Works, Halifax, N.S.; the Maritime Coal, Railway and Power Co., Joggins, N.S.; the Record Foundry and Machine Co., Moncton, N.B.; and the Rocky Mountain Cement Co., Blairmore, Alta.



STEEL YARD

the machinery used throughout the plant, with the exception of a few small machines in the machine shop, is driven by individual motor drives.

General.

The shops are heated by an underground system of ducts running underneath, outlets being taken off at intervals. Through these, a blast of hot air is blown by means of fans located at various points round the shop. This installation was made by Sheldons, Ltd., Galt, Ont.

At the east side of the wood-working shop, situated opposite the power house, is located a storeroom, 50 x 100 feet, in which is kept all the small material used in the construction of the cars, such as bolts, etc., and all small tools used around the shop. This store room is equipped with every modern device to facilitate the transportation and disposal of these materials. To the east of the shops, standing by itself, as will be seen in the plan, is located a dry kiln for drying the flooring, roofing and smaller wood parts used in the construction of the car. This kiln was made by the Moore Co., of Jacksonville, Florida.

draughting room, and a restaurant for supplying lunch to the office force. Also a blue print room with continuous blue print machine, and a photograph room.

In a plant of this size where work is carried through with great rapidity, there is always some one getting their fingers jammed or sustaining other minor injuries. Up to the present, no fatal injuries have to be recorded, but to guard against injuries of any nature, they have equipped a complete emergency hospital with an ambulance in charge of a first aid man on the ground. Here, injuries of a minor nature are treated, and serious cases are given first aid treatment before being taken to a regular hospital.

There are two lavatories and wash-rooms situated in the vicinity of the shops, with modern equipment, and sanitary in every way. The wash bowls being porcelain lined, and accommodating a dozen or more men each at a time.

Executive and Operating Staff.

President, Sir John Gibson, Toronto; vice-president, and general manager, Basil Magor, Hamilton; secy-treas., Mottyn Lewis, Montreal.

Features of a Canadian Quick Revolution Steam Engine

The vertical, enclosed, quick revolution, forced lubrication type engine for direct driving of electric generators and other high-speed machinery combines the advantages of small space required, low first cost and maintenance costs, absolute reliability, economy, and simplicity. In recent years, its installation in Canada has been on a large and continuously increasing scale.

THE engines described in this article represent the highest development of the marine type of vertical, enclosed, quick revolution, forced lubrication unit as adapted to land conditions, and its extensive and increasing

ment of indicator cocks and pipes. The top cylinder covers are strong, light castings, fitting into the cylinder counterbore. The interior surfaces are polished, as are also such portions of the outside that are not filled in with

quiring taking up, as the piston and rod and crosshead can be held up from the top and not packed up from inside, thus leaving the mechanic clear space inside which to work.

Valves and Valve Gear.

Owing to the engines being vertical there is practically no wear on the piston valves with which they are fitted.

The steam enters on the inside edges of the valve, and exhausts at the outside; this arrangement keeps the valve spindles and packings working in steam of comparatively low pressure and temperature, thus saving the packings and making the lubrication of the rods more satisfactory, which is specially important with superheated steam. Generally, the valves are simple hobbin shaped castings accurately turned and ground up to fit lapped out seats. In large engines they are fitted with floating rings similar to those described further on in this article for H.P. pistons of smaller engines.

In all compound and triple expansion engines (except for certain special conditions of running) the H.P. valve is under the control of the governor, and is rotated a few degrees on its spindle to vary the point of cut-off, the steaming edges of the valve being at an angle of 45 degs. to correspond with the openings in the valve seat. The cut-off is

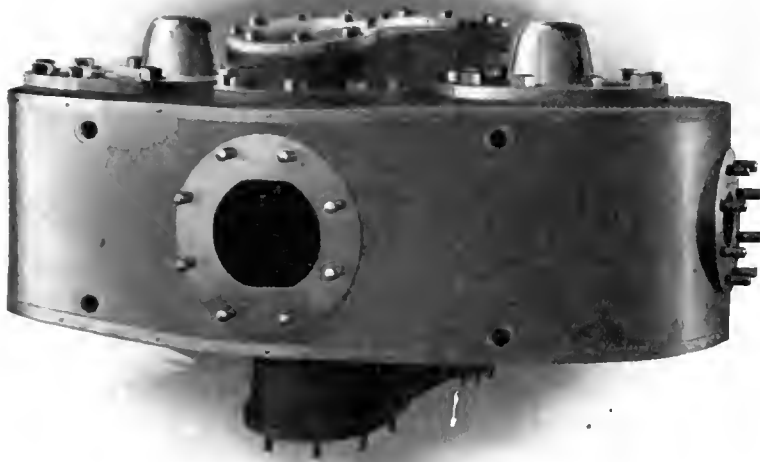

CYLINDERS FOR TWO CRANK ENGINE.

adoption, the world over, by the British and other Admiralties, the great ocean steamship lines, municipal and other power stations, etc., prove that it has satisfied the requirements of the highest and most exacting authorities. The Goldie & McCulloch Co., Ltd., Galt, Ont., are prepared to manufacture and supply units ranging from 10 to 1,500 horsepower, and suitable for working steam pressures up to 200 pounds per square inch.

Cylinders.

These are cast singly or in pairs, according to size and type of engine, being made of special metal and designed so that they can be completely enclosed in sheet metal secured with polished bands and bright screws. Non-conducting composition is laid on below the cylinder sheeting to a depth of at least 2½ inches. The ports are deep, short and direct, giving free passage for steam, and the valve seats are bored and lapped out to truly cylindrical shape. Escape valves and drain cocks of neat and massive design are fitted on each end of the cylinders and elsewhere as necessary, and connections are made for attach-

ment of indicator cocks and pipes. The top cylinder covers are strong, light castings, fitting into the cylinder counterbore. The interior surfaces are polished, as are also such portions of the outside that are not filled in with

non-conducting composition and covered with neat sheet steel ring. In the centre at the top is a screwed brass plug which can be removed for insertion of a

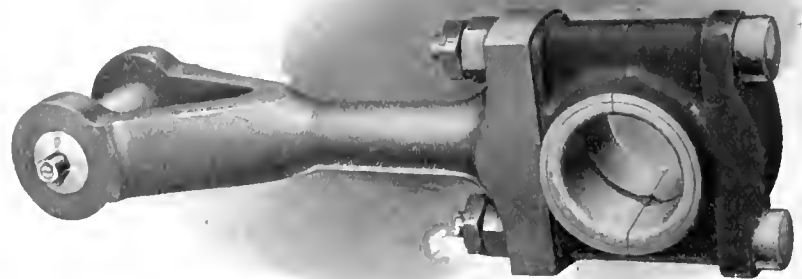

CONNECTING ROD.

lifting bolt for screwing into a tapped hole in the end of the piston rods. This will be found convenient in case of the crosshead pin or crank pin brasses re-

changed by altering the lap and lead, but the exhaust timing is not affected.

In very large engines the H.P. valve is operated by a relay cylinder, and the

work on the governor is further relieved, it only having to operate the small control valve of the relay cylinder. The advantage of this arrangement will be obvious to any engineer. The valves are also all balanced in similar manner to the pistons, and the spindles are of large diameter, giving good rubbing surface and great stiffness, these being essential in high speed work. The bottom ends are fitted with adjustable brasses with large wearing surfaces. Valve covers are light and strong, and the valves can easily be withdrawn by removing the top covers. The bottom covers have deep stuffing

tion pump. The eccentric rods are stiff short steel forgings machined all over, and drilled up the centre to carry oil from the eccentrics to the valve spindle pins, which are of hardened steel ground accurately to size. These rods are secured to palms on the eccentric straps by studs and locking pins.

Throttle Valve.

The throttle valve consists of a cylindrical chamber with a flanged branch bolting on to the H.P. cylinder. The valve is of cast iron, of the double ported piston type, working on the outside of a cast iron sleeve seat, both valve and seat being ground accurately steam-

hollow governor rod, which carries the water down to a small drain box and prevents unsightly or messy water dripping about the engine.

Pistons, Rods and Rings.

The low pressure pistons are of marine type, being coned shells of great strength and lightness, and made of either cast or forged steel, according to size. They are turned and polished all over, and fitted with "Rowan's" packing rings. These rings are also fitted to the H.P. pistons of the larger engines, and in cases where superheated steam is used, have a restraining tongue piece to



END VIEW OF SINGLE CYLINDER ENGINE.

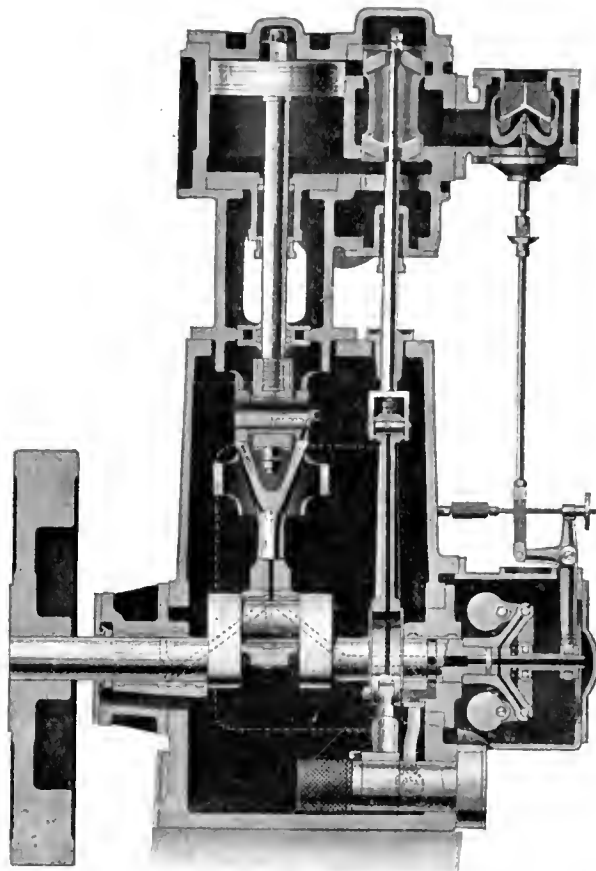

SECTIONAL FRONT VIEW OF SINGLE CYLINDER ENGINE.

boxes, and below these and fixed to the top of the vertical frame, are rigid guides for the spindles, these guides being either brass or babbitt bushed, with deep edges to collect any water that may drip down valve spindles, this water being drained off by a system of pipes.

The eccentric straps are of malleable iron, and are lined with babbitt secured by key pieces cast in the straps. An oil groove is turned in the babbitt and an oil hole leads to this from the crank shaft. The eccentrics are also of malleable iron, and secured to crank shaft by steel keys and screws. They are in halves and easily removable. On one of the eccentric straps, lugs are cast, and a pin fixed for driving the forced lubrica-

tion pump. The design is such that there is no tendency to distortion, due to varying temperatures of steam, being specially suited for working with superheated steam. The steaming edges of valve and seat are dressed perfectly parallel, and the valve with its spindle and rod weigh only a few pounds even in large sized engines. The spindle is of Muntz metal working in a long frictionless brass sleeve, no packing being used, leakage grooves being turned in the spindle which is a ground fit for the sleeve. The bottom end of the spindle has a pin joint, the bottom half forming also a small drip dish, which collects any water that may leak past the spindle, and this dish is screwed into the

prevent them expanding beyond a predetermined amount. In the single cylinder engines, and smaller twin and compound engines, a deep solid cast iron "floating" ring is used, accurately ground to size. This ring has "labyrinth" grooves turned on the outer face which serve to retain oil, assist lubrication, and prevent steam passing.

The H.P. piston for either this ring or the "Rowan's" type is a coned cast iron block in two pieces, and polished all over. The H.P. piston in compound engines is exactly the same weight as is the L.P. piston, although of different diameter. They are weighed separately with their corresponding rings, piston and connecting rods, and the difference

in the weight is turned out of the inside of the two halves of the H.P. piston, which is cast purposely a little heavier than the L.P., to allow for any inaccuracy in balance being corrected before assembling. In three crank en-

flange of distance pieces and top of frame is made oil tight. The space between the steam packings and the wiper packings on the piston rods is never less than the stroke of the engine, thus preventing the rubbing portions of the rods

and insuring a steam tight joint at the cylinder.

Vertical Frame.

The vertical frame is of rigid design and pleasing appearance, and has large doors for access to and examination of the enclosed portions of the engine. All faces are machined and all joints are made oil tight; openings are formed in the top to receive the cylinder supports and the valve spindle guides; there are also openings in the back side with facings for attachment of indicating gear. The vertical frame is dressed, cleaned and varnished inside.

Bed Plate.

The bed plate is of strong and rigid box girder construction, with bottom cast-in solid, to form a tank to contain the forced lubrication pump and its oil supply. A drain cock to run off the oil, for cleaning or renewal; light doors for examination of the oil pump, relief valve, and oil strainer are also fitted.

Crank Shaft.

The crank shaft is a solid steel forging, and the short throw and thick crank webs, also the manner in which the shaft is supported with a bearing close

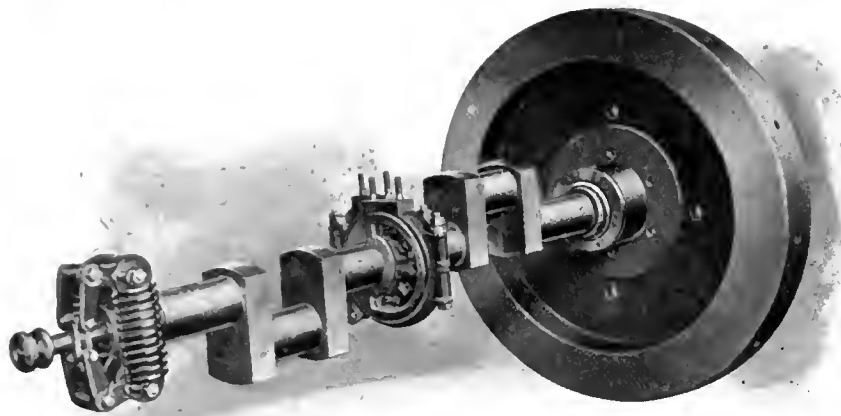

CRANK SHAFT FOR 2-CYLINDER ENGINE, SHOWING GOVERNOR MECHANISM, ECCENTRIC AND FLYWHEEL.

gines, the pistons, etc., are balanced in a similar manner to the two crank.

The rods are of special steel, accurately turned and ground to correct diameter, and secured to the pistons by deep nuts with locking pins. The pins for the crosshead brasses are suitably drilled for oil circulation, as are also the crosshead shoes. In very large engines, the crosshead shoes have a further supply of oil brought to the back of the guide by piping.

Connecting Rods.

The connecting rods are of marine pattern, being short steel forgings with brass bushes lined with babbit for the crank pin end, and hard brass or bronze bushes for the crosshead pins. The crank pin bushes have oil channels same as in crank bearings, and the babbit is securely dovetailed in place. All bolts are fitted, and have lock nuts and safety pins. The connecting rod is also drilled to carry oil from the crank shaft to the crosshead pins.

Distance Pieces.

The distance pieces consist of strong, short circular castings, mounted on top of the vertical frame, and extended down into the inside of same to form crosshead guides, which are circular in form. The top ends form the bottom covers of cylinders, and the inner surface is polished. The piston rod stuffing boxes are also formed in these castings, as are also recesses for the wiper packings, and as the part which enters the cylinder is turned to fit the cylinder counter bore, absolute accuracy of alignment is secured. Openings are formed in the portion above the vertical frame for access to piston rod stuffing boxes, and the joint between bottom

working in two different types of packing, and likewise hindering the crank case oil passing up with the rod into the cylinder and forming ridges of charred oil on the rods, as frequently happens

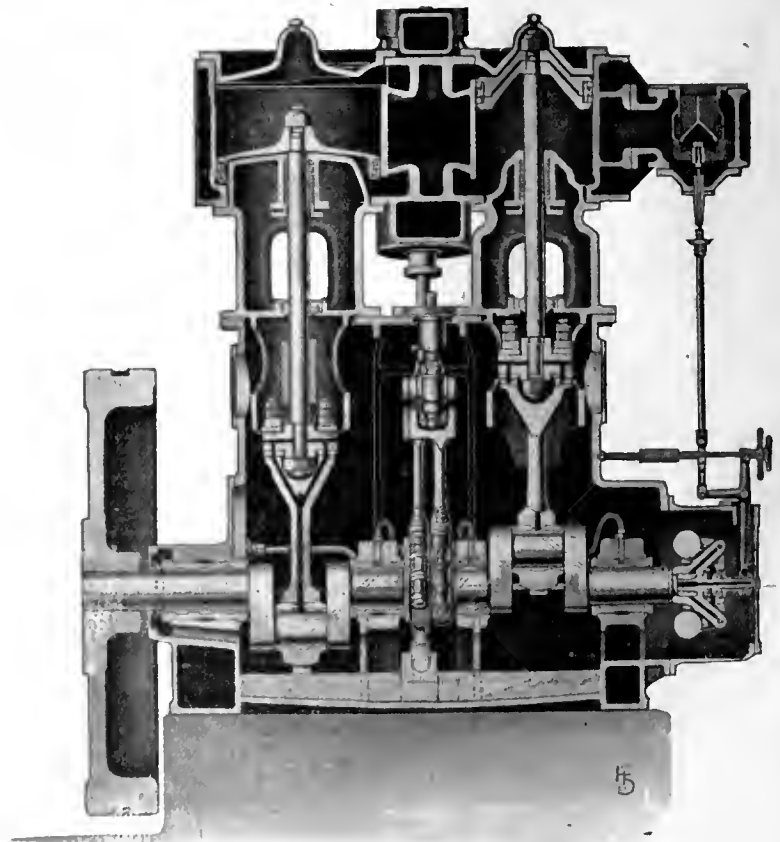

SECTIONAL FRONT VIEW OF TWO-CYLINDER COMPOUND ENGINE.

when the distance between the two packings is less than the stroke. All joints are formed on external flanges, thus giving easy access to all nuts and studs,

to each web, give great stiffness and strength. An oil supply is carried to each crank shaft bearing, and from thence by suitable passages to the eccen-

tries and crank pins from which it is further distributed as necessary. The outer end next the flywheel is increased in diameter, and has an extra long bearing.

Flywheel.

The flywheel is cast in one piece, as is necessary owing to the high peripheral speeds. It is of the solid plate type, turned all over for balance, polished on rim, and is forced and keyed on to the shaft. The outer face is made to form a coupling for the end of a generator, fan, centrifugal pump, or other shaft.

The barring lever for the smaller engines is so designed that with the stop valve slightly open when starting the engine, and it starts off quickly, the

weights are of the same material, formed at the ends of a pair of bell crank levers. The carrying pins are of large surface, and are under forced lubrication, the centrifugal pull of the weights being taken directly by the main springs, the ends of which hook over pins in the weights. There is thus practically no force being exerted on the point of suspension (the carrying pins), except that due to the weight of the throttle valve, etc. The inner ends of the bell crank levers carry large pins engaging in the collar of a steel sliding sleeve, this sleeve working on a small spindle carried in the crank shaft and drilled for oil circulation; the outer end of the sleeve has also a collar engaging

Crank Shaft Bearings.

The crank shaft bearings are strong cast iron bushes, lined with best quality of babbitt secured by locking grooves which run lengthwise and crosswise in the shells. The shells are turned on the outside and the engine bed is bored to suit. The babbitt is grooved with circular channels for the oil supply, the oil entering through a pipe screwed into the top shell, and passing through the cap.

In compound and twin cylinder engines, there are four bearings, and in three crank engines (compound or triple), there are six, thus giving a bearing close up to each side of the crank webs. The bearing next the flywheel is

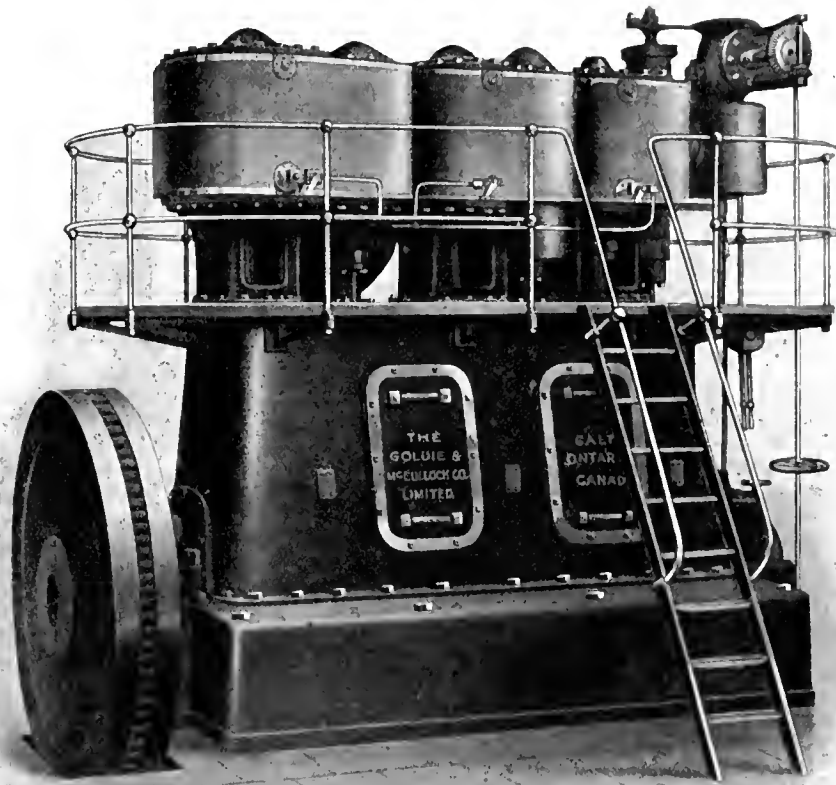

THREE-CYLINDER COMPOUND TRIPLE EXPANSION ENGINE.

lever disengages itself, and remains in the engineer's hand. In the larger engines a bracket with a pawl and long removable lever is supplied.

Governor.

The governor casing is a cylindrical box spigotted into the end of the bed plate and vertical frame, and secured to same with an oil tight joint. A large circular cover on the front end, which can be removed whilst the engine is running, gives easy access to all parts.

The governor is of the centrifugal spring loaded type, mounted directly on the crank shaft. The weight carrier or fork is a malleable casting, and the

with the bottom of the governor lever, this also being lubricated under pressure. The governor lever extends to the outside of the casing and is secured to a small shaft, the ends of which rest on pin point suspension to minimise friction. The bottom end of the throttle valve rod is attached to this lever, as is also an auxiliary spring and small hand-wheel by means of which the speed can be varied whilst running within certain limits. When the H.P. valve is of the expansion type, a second lever is attached to the small shaft and carries a buffer spring box attached to the expansion gear rod.

larger in the bore and longer than any of the others, and the cap is made with oil tight joints and fitted on the outside with oil cover and thrower to prevent oil escaping.

Oil Pump.

A special feature of these engines is the pump for supplying the oil under pressure to the various bearings. At high speeds of rotation, ordinary valves will not act, and the pump has therefore to be designed to work without valves. The oil pump consists of only 3 parts, a casing, an oscillating plug, and a plunger. In the casing are the suction and discharge chambers, each communicating

by a single rectangular port with a circular chamber which is bored out to receive the oscillating plug. The plug is turned to fit this chamber and has a hollow lower half, in which is a single rectangular port. A small steel barrel is secured into the upper half of the plug, and, in this the brass plunger is worked up and down by the eccentric. At the same time, the eccentric imparts an oscillatory motion to the plug, alternately bringing the port in the plug opposite the suction and discharge ports in the casing. A spring loaded relief valve, for regulating the oil pressure, is under control of the engine attendant by means of a small spindle with handwheel passing to the outside of the engine bed, a small gauge indicating the pressure.

Fitting close on to the suction chamber of the oil pump is a strainer of perforated metal, with fine mesh brass gauze, clipped on. The sheet metal is soldered to brass ends, one of these having a balled face to find its own seating in a corresponding socket on the pump. A spring at the back end of the strainer presses it close to the pump, and by lifting a small cover in the engine bed, and pressing back the spring, the strainer can be removed for inspection and cleaning. The oil is carried by piping from the discharge chamber to each

needed by pipes inside the vertical frame to the cylinder distance pieces and valve spindle guides. Cylinder oil and water that may come down the piston and valve rods, and any crank case oil that may work up, are collected by suitable wiper packings in the distance pieces, etc., passed down the pipes to the separator, which automatically separates the oil and water, returning the first to the engine bed, and allowing the water to escape by a suitable drain.

Balancing.

Under all ordinary circumstances, balance weights are not required as each line of similar moving parts is exactly the same weight, and the distance between the crank centres is very short. In special cases, balance weights are sometimes fitted, the size and angular position of same being carefully determined to ensure the maximum possible reduction in both unbalanced forces and couples. In single crank engines, balance weights are employed, and in the smaller sizes, these are formed out of portions of the crank webs.

Warming Up Valves and Drain Pipes.

In larger engines, auxiliary warming and starting valves are fitted so that the cylinders can be thoroughly warmed up and the engine easily started. The gear for operating these is placed close to the

CHIEF INSPECTOR OF BOILERS, ONTARIO PROVINCE.

D. M. MEDCALF, who has been inspector of boilers and machinery for the Province of Ontario public institutions during the past eight years, is now chief inspector of steam boilers



D. M. MEDCALF.

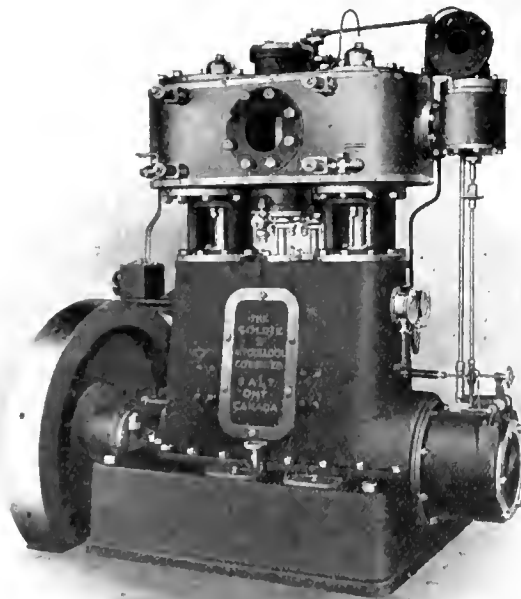

BACK VIEW OF COMPOUND TWO-CYLINDER ENGINE.

crank bearing, and is further distributed from these throughout the engine.

Oil and Water Separator.

As water getting into the oil in the engine bed would cause trouble and waste, an automatic oil and water separator is fixed on the engine bed and con-

nects to the main steam valve. In large engines, the cylinder drain cocks are operated by means of a lever or levers placed convenient to the starting point, and neat wrought iron platforms, ladders and handrails are fitted where necessary to give access to all parts of the engine.

for that territory, under the new Steam Boilers Act, with offices in the Parliament Buildings' new branch, Queen's Park, Toronto. The new Steam Boilers Act will come into force and take effect on and after July 1st, 1913. Under the new Act, Mr. Medcalf's duties will embrace a much wider range than heretofore, as all new boilers built in or entering the province will be subject to inspection by a qualified staff appointed by the Minister of Public Works, relative to their design, construction, etc., in conformity with the regulations.

Mr. Medcalf, in December, 1909, represented Ontario at a conference of Provincial Boiler Inspectors held in Regina, Sask. There, rules and regulations were drafted, and subsequently adopted by the Provinces of Alberta and Saskatchewan. Ontario has now adopted the like regulations, and it is fair to assume that the other provinces will approve and recognize these, with a view to securing uniformity throughout the entire Dominion ultimately.

Born in Toronto 40 years ago, and after serving his apprenticeship as a machinist with the Polson Iron Works, Toronto, Mr. Medcalf filled positions successively at the Lake Erie Engineering Works, Buffalo; the Baldwin Locomotive Works, Philadelphia; the C.P.R. shops, Winnipeg; the N.P. Railway shops, Brainerd, Minn.; the I.C.R.K. shops, Chicago, and with the John Inglis Co., Toronto.

Some Essentials to Success in Machine Shop Practice*

By F. R. Parsons

The writer of this article shows that hearty co-operation of employer, foreman and operator, together with a machine tool for the latter, about which there is no question of accuracy for the performance of the particular work required, are the great essentials for success to all concerned with machine shop productive output.

IN some machine shops where precision is the predominating feature, the distinguishing line between success and failure in an operation is often represented by no more than one division on the graduated sleeve of a micrometer. Now, to attain this degree of accuracy, and follow it up day after day with a consistency indispensable to successful production on competitive lines, something more than ordinary precaution and care need to be observed in order to insure a continuity of conditions which are not liable to be imperilled by outside influences, subjected to the vagaries of chance, or dependent upon the limitations of human endeavors.

Such conditions are, however, up to a certain point, insured by the employment of automatic, or semi-automatic machinery; human responsibility in this direction being thus almost completely eliminated, but with this particular phase of the question the writer is not at present so much concerned. What he has set out to do is to show, if possible, how some of the apparently inexplicable failures peculiar to a machine shop are caused; and to suggest a series of remedies, which, if followed out, should have a beneficial effect both upon operations and operatives who are engaged in this class of work, and who are dependent more upon individual skill than mechanical aid for accuracy of production.

The Machine Feature.

It will be readily admitted that one of the chief essentials to success in the production of accurate machine work must be that the machine itself is fully qualified in every respect to perform accurate work, irrespective of whatever class of labor may be operating it. With this accepted as a basis, it follows that if the second part of the proposition is established, and with a mathematically correct machine goes a workman well skilled in its manipulation, nothing else is deemed necessary in order to produce mathematically correct results; but this is a mistake. Given a reliable machine and a careful expert workman, his immediate surroundings and the conditions under which he is called upon to perform his duties may sometimes be such as will altogether preclude him from doing justice either to himself or his machine.

The Operator's Comfort.

It is a well-established fact that the human element is at its best when his creature comforts are such as will give him no cause to think about them. In other words, it cannot reasonably be expected of a workman that he will give that amount of thought and care necessary to his work, if, we will say, the situation of his machine be such that he has, perforce, to be continually straining his eyes to see what he is doing. Neither can he be expected to concentrate his thoughts and attention to his work if his feet and hands are chilled owing to a cold floor or a draughty shop. Or, again, how can he maintain an unbroken interest in his occupation if he has continually to dodge truck-loads of material which are for ever passing and re-passing down the machine aisle? Quietude and comfort are indispensable agencies to the man whose work demands a close concentration and exactness of finish.

The Personal Feature.

From external comfort of surroundings one naturally passes to the individual. The writer has heard an employee jeered at, and adverse comments passed upon him by his employers because he would come to work in high collars and low cuffs, and with a gold ring upon his finger; but when informed as to his abilities as a workman, they discovered that he was one of the most reliable, accurate, and painstaking men in the shop, and forthwith altered their opinion of him to one of respect.

There is, after all, a saving grace in being styled a dude, if only by its adoption a similar study of detail and attention to work be induced. It is well known that a workman, careful and exacting in dress and toilet will invariably insist upon more comfortable surroundings and conditions under which to work than will the sloven who would not grumble overmuch if put into a pig's sty. You wouldn't, however, be inclined to entrust the latter with a precision job!

The Employer's Duty.

We have seen that certain outside influences have a direct bearing upon the tendency to produce either good work or bad. Assuming, then, that no fault is to be found with the capabilities of

the machine, the inability to establish a continuity of good results will invariably be found to spring from causes which will come under one of three heads—that is to say, adverse conditions for which either the employer, the foreman, or the operator is directly responsible. Therefore what has been said up to the present would appear to come under the heading of the first named. So to sum up the general conditions under which men work, their immediate surroundings, the comfort of the shop, the care for their health and bodily welfare, must ever remain the religious duty of an employer who expects the best out of his men and the most through his machines.

The Foreman's Responsibility.

Now, just a word in regard to the responsibilities attached to a foreman. As the active medium between the management (or employer) and workmen, much of the success attending the output of a shop depends upon the degree of tact and judgment possessed by this individual. You will observe that in these specific qualities, ability is not included—and for this reason: A foreman may possess to the last degree all the ability necessary to the successful running of a shop as far as an intimate and expert knowledge of the various operations involved therein is concerned, but, owing to a lack of tact and judgment in the art of handling men, may prove himself an utter failure.

It would, perhaps, be quite safe to say that a foreman possessing in full the latter qualities, but somewhat lacking in expert knowledge would be likely to get more out of his men than one whose qualities are the other way about. A workman is ever ready to condone a technical error or fault arising out of a foreman's misjudgment, or even lack of knowledge, providing a feeling of good fellowship exists between them, and he himself will be the first to hasten to set things right again for both their sakes; but an unmerited and personal affront delivered by a tactless and perhaps irate foreman when things have not gone quite smoothly will have upon the workman quite a reverse effect.

Much can be done by a tactful, conscientious foreman towards the smooth and efficient running of a shop. He can be firm without being overbearing, par-

*From Page's Weekly.

ticular without being fussy, officious without being dictatorial, and yet friendly without sacrificing dignity. Getting to the top notch of output is better accomplished by a policy of friendliness than one of driving; and a conscientious workman will do more for the sake of such a foreman, or yet for the love of his work and his own reputation, than he will by being bullied into coercion.

If a workman is engaged on an operation entailing a close concentration, one that necessitates the exercising of all his thoughts and care to the exclusion of all else, nothing is more irritating, or likely to discompose him, than for a foreman to be continually interfering with him in pointing out trivial and unimportant details which to an intelligent man are obvious. If attention must be drawn to some operative detail, or a correction necessary, let it be done at a more opportune moment, and not in the middle of an operation; and never in a manner or tones calculated to draw the attention of the whole shop.

When a journeyman, the writer worked for a time under a blustering, bullying foreman, with manner rough and uncouth, and a tongue voluble and profane. Incensed at the methods being adapted by a certain vise hand, who, by the way, was an experienced and capable mechanic, he snatched the tools out of the latter's hands, unceremoniously pushed him on one side, and with an oath proceeded to instruct the other how he should use them. The momentary surprise over, the mechanic promptly knocked him down, then calmly picked up his tools, put on his coat and applied at the office for his back time.

The Workman's Responsibility.

Now for a word on the responsibilities of a workman. It is a common failing amongst machine operators that if they just do what they are told, nothing further is expected of them. One individual once told the writer that "he wasn't paid to think, that was a foreman's business; he was there to do what he was told." Undeniably this is the spirit that animates many a mechanic to-day, and is productive of much of the apathy and indifference which characterizes their work; but in all justice to them, it must be said that this feeling is, to a considerable extent, fostered by an almost complete absence of any incentive to take the initiative in exercising their brains to their own profit. They realize that it matters nothing to them if they can save a few minutes on a certain operation; for even if this is possible, and they are producing at piece-work rates, they are liable to have their rate cut down an equivalent amount in order that the whole of the

extra profit shall revert to the firm. This is not only an unwise policy, but an unfair one. Although ordinarily a workman is paid for his best services, it can scarcely be urged that this covers extraordinary services rendered to the firm in the shape of labor-saving innovations.

Apart from this, there are many little failures on the part of a workman which had he used a grain of thought, might, instead, have been turned into successes. The writer remembers a case where a dozen steel shafts were returned as useless owing to their being 0.005 in. small in diameter. These shafts had been machined by one of the most experienced turners, who was instructed to use the greatest care in getting the ends to the specified size, namely, 5.005 in.—this being a forcing fit. Naturally, the turner was called over the coals, but all that he could say in defence was that he felt positive they were to the correct dimension, as shown by the horse-shoe gauge, when they left his hands, and if they were wrong, the latter instrument must be at fault. This, however, on being checked with an inside micrometer, was found quite in order.

Source of Error.

As others had to be made to replace, a keen supervision was kept. It was during this supervision that the writer alighted on what turned out to be the reason for the error. Watching the machinist checking the diameter of the new shaft, it occurred to him to feel its temperature. The roughing-down had been accomplished with a fairly high speed and a coarse feed, consequently when it came to the finishing cuts, the shaft end was still quite warm, and would have expanded at the least two or three thousandths.

To make matters worse, the horse-shoe gauge had been lying on the lathe bed, and being winter time, and the shop a fairly cold one, it was reasonable to expect that its contraction on this account would be sufficient to be appreciable. To determine this, a test was made of it by means of the inside micrometer, when it was found that its contraction registered just a thousandth. This error, together with the other, brought about by the expansion of the shaft, clearly accounted for the former discrepancy. Needless to say, precautions were taken in time to avoid a recurrence of the trouble.

The Forethought Feature.

Forethought in the matter of details must ever be the aim of a workman if he is to be fully insured against the many risks involved in machine operations. The factors militating against success are so numerous, yet withal sometimes so obscure, that it needs all

one's attention to circumvent them. A loose spindle, a worn screw or slide, a faulty centre, a cracked ball race, a defective clutch cone, a springy tool post may all be classed as obscure causes from which arise endless trouble if permitted to exist.

Faults in work due to an inefficient operator may be remedied by replacement, and the trouble ceases forthwith; but those inherent in the machine itself require something more than a replacement of the human agent, and it is up to a good operator to insist upon remedial measures being taken, since not only his own, but the reputation of the shop depends upon it. To get the best out of a machine, the machine must be of the best; and to get the most out of a man he must be treated as a man.



OLD HIGHLANDS BRIDGE BEING REPLACED.

THE last of the old bridge over the River St. Lawrence, between Highlands Station, near Montreal, and the Adirondack, is gone, and the work of strengthening the foundation for the new spans is almost complete, while at the Dominion Bridge Co.'s plant the preparation and assembling of the new portions for the two huge 408 feet spans is being pushed forward as rapidly as possible, so that when all is ready there will be no time lost in floating them into place as last year. The work is scheduled to be finally completed for this fall, and by that time will have occupied about three years to build.



C. P. R. CONSTRUCTION.

AT the moment, thousands of men are engaged at various parts of the C. P. R. system on every possible kind of construction work—double-tracking, erection of additions to hotels, round-houses, new sheds, etc., but none are so interesting to Montreal as the immediate work on the C. P. R. between Farnham and St. Johns, Que.

Very rapid progress is being made, and certain lengths are already in use which are facilitating the moving of trains between Montreal and the eastern points. Two steam shovels have been hard at work reducing Johnson's Mount to a depth of several feet, and trains are being operated over the low level during the raising of the permanent track.



Gordon Phillips, Assistant Industrial Commissioner, Winnipeg, will be offered the position of Industrial Commissioner in London, Ont., at a salary of \$3,000.

Educating the Public in Methods of Preventing Smoke

By O. Monnett*

The problem of "How to deal with the Smoke Nuisance" is one in which manufacturers and corporations are intensely interested. Careful note should be made of the satisfactory solution arrived at by the City of Chicago, the details of which form the subject matter of this article.

THE Chicago Smoke Department has adopted a policy of educating the public in methods of preventing smoke. Plant owners, engineers, and firemen are instructed as to the best way of utilizing the equipment they have, and are advised of the proper method of furnace construction adaptable to their conditions. For this educational work the Smoke Department has a number of expert engineers.

Mode of Procedure.

The problem of each plant which violates the law by emitting dense smoke, is carefully investigated and thoroughly considered by the engineers of the Department, before recommendations or suggestions are made to the owner as to the best way to handle his plant, or as to the reconstruction work necessary, so that he may operate with a minimum amount of smoke. Many times, entire boiler plants are rebuilt in order to stop the smoke, and often furnaces are reconstructed throughout. It sometimes happens that, after a new plant is put in operation, it smokes, and the operating crew find it difficult to run without making the latter objectionable. The Smoke Department gives a plant special attention, and keeps in close touch with the work until the cause of the trouble is definitely known, and changes made that will rectify matters. In some cases, builders purposely use inferior material and make poor installations. When the Department learns of such, special effort is made to have the work of doubtful merit improved upon, and in a number of instances, further work on a plant has been stopped until certain objectionable features have been removed.

Automatic Stokers.

There are many good boilers and furnaces on the market to-day, and, the problem is to have the furnace and boiler arrangements such as to get the best results. There are no furnaces built that will work satisfactorily in all places, because of the great variations in the characteristics of different plants. The majority of furnaces installed in Chicago since the organization of the present Smoke Department have been designed specially for the plants in which they are used. It is the aim of the De-

partment to get automatic stokers in all plants that are large enough to warrant the expenditure, for so long as furnaces are hand fired, there will be trouble in keeping the smoke down, because so much depends upon the conscientious effort of the operators. There are surprisingly few hand-fired furnaces on the market that can utilize Middle Western coals, even though proper draft facilities are provided and average care in operation is used, without producing considerable objectionable smoke. It is interesting, though, to note that most of the furnaces which can comply with these requirements are not patented.

The Operation Feature.

It has been the experience of the Department that practically every mechanical stoker on the market to-day can be applied to boilers under circumstances which will allow it to run satisfactorily from a smoke standpoint. There have been developed, and are in extensive use in Chicago, various designs of hand fired furnaces for utilizing coal, wood refuse, etc., that are adaptable to horizontal return tubular or water tube boilers. However, it is a study to know whether a plant is surrounded by all the proper safeguards, and to be certain of the results that will be had when the furnaces are put in operation.

There is no standard set of conditions which will meet every case. It is the aim of the Smoke Department to get all the plants to go in under the best engineering conditions possible. A plant in the first place should be correctly designed and built, with due consideration given to all requirements for smokeless combustion, and then it should be properly operated. Any furnace designed for smokeless operation, whether it be mechanically or hand fired, is merely a tool provided for the fireman in order that certain work can be done. Therefore, proper operation is the most important thing of all, and this can only be regularly obtained by a strict enforcement of a smoke ordinance by the city.

If an existing plant cannot run within the ordinance, and the necessary changes to fit it so as to run within the ordinance are practically out of the question, then the Department can and does recommend a coal of less volatile content than the grade ordinarily used, but this

is taken more or less as a makeshift, due to the fact that semi-bituminous coal is not always obtainable in the Chicago market on account of weather conditions, obstructed railway traffic or to labor troubles, and this recommendation, therefore, is made only to tide the plant over until such time as it can be rebuilt.

Condition Studied Thoroughly.

A plant that violates the smoke ordinance at frequent intervals is given special attention by the engineers of the Department. These engineers visit the plant, while it is under operation. After a thorough investigation of conditions, such as fluctuation of load and draft facilities, which would include breeching area, size of stack, gas passages through the boilers, etc., together with the character of fuel, construction of furnace and every other item which has any bearing whatever upon the operation of the plant, tending to produce or prevent smoke, has been taken into consideration, recommendations are made as to the best course to pursue in order to eliminate smoke.

In plants where considerable reconstruction is necessary, these visits often cover a period of several weeks, and in some cases even months, before the engineer is thoroughly familiar with all the difficulties to be overcome in the plant, and is in a position to make recommendations which, if followed, may necessitate the expenditure of considerable money. Owners, consulting engineers and chief engineers of plants sometimes think that the Department's recommendations are far more sweeping than are necessary for the results sought, and in cases of this kind it is necessary to work with them and devise a scheme whereby such work as they do will be a benefit and a part of the general plan of improvement to be executed step by step.

Typical Example.

The following is a case in point: The plant has ten 450 h.p. water tube boilers with chain grate stokers. They were vertically baffled and set six feet from the boiler header to the floor line. The grates were entirely under the boilers. The breeching was behind the boilers with uptake connections one-half the width of the boiler setting, and the breeching was of comparatively small area, leading directly to the stack, of ample area, and 275 feet high. The De-

*Smoke Inspector of Chicago, in "Industrial Canada."

partment's recommendations were, to lower the floor three feet, and draw the grates out four feet; lower the combustion chamber floor to the rear of the bridge wall, giving a freer passage for gases from the second to the third pass of the boilers; enlarge the dampers to the full width of the boiler setting; enlarge the opening into the stack and increase the size of the breeching back of the five boilers nearest to the stack.

In this particular case, the company and their consulting engineers did not think that work of an extensive nature was necessary, therefore, it was decided to lower the floor three feet and draw the grates out four feet. This work was done and there was a noticeable improvement in the amount of smoke made, and a slight increase in the capacity of the plant, with better economy. Later, the company was persuaded to lower the floor to the rear of the bridge wall. A few months later, the opening into the stack was enlarged and the breeching increased to an area that was ample. There remains yet to be done the enlarging of the dampers and some slight modifications in the construction of the ignition arches of the furnaces, but as the plant now is, the capacity has been increased more than 60 per cent., as compared with what it was before alteration work was started three years ago. The efficiency has not been impaired, and the smoke conditions have been improved so that at the present time it is seldom that the plant makes objectionable smoke.

There is another plant which had eight chain grate stokers under water tube boilers vertically baffled. They were burning shavings on most of these grates, and coal on some of them. The plant has been changed. Six of the chain grates have been taken out. Dutch oven furnaces with three span deflection arches were installed in their stead. The entire system of handling shavings has been materially altered. This work took dual once told the writer to do after wasn't paid to think, that at could be man's business; he was necessary for what he was told." Undoubtedly at all is the spirit that animates men at first, mechanic to-day, and is produced by much of the apathy and indifference, which characterizes their work. Now, all justice to them, it must be separate, this feeling is, to a considerable extent, fostered by an almost complete absence of any incentive to take the initiative, exercising their brains to their own profit. They realize that it matters nothing to them if they can save a few minutes on a certain operation; for even if this is possible, and they are producing at piece-work rates, they are liable to have their rate cut down an equivalent amount in order that the whole of the

it expects the large plant as well as the small one to comply with the smoke ordinance. As a general rule, the Smoke Department first finds out what is necessary to be done in a plant in order that it may operate without violating the ordinance, and an effort is then made to get the owners to do the work that will give satisfactory results. If it is impossible to get sufficient co-operation from the owners so that they will work out the solution of the smoke problem in their particular instance, resort is made to the court for prosecution on evidence of violations by their chimneys. When, in the judgment of the Department, a consistent effort is made to better conditions, prosecution for violations is not instituted, as the purpose of the Smoke Department is to eliminate smoke and not cause fines. The most difficult part in building or operating a plant or furnace properly is to get the hearty co-operation of all parties having anything to do with the job. After getting this co-operation the rest of the problem is comparatively simple. The results to be had without such co-operation will not be satisfactory.

Smoke Department Criticized.

The Department has been subject to considerable criticism for its activity in undertaking to advise people in trouble with regard to reconstruction work. However, it must be borne in mind that the purpose of the Department is to suppress smoke; that the public is looking to the Department to relieve it of the unnecessary air pollution caused by smoking chimneys, and that the Department must, of necessity, get action. To illustrate this point a recent case may be cited, in which an old type mechanical furnace was giving a great deal of smoke trouble.

A reputable consulting engineer approached the company with a proposition to put the plant on its feet both from efficiency and smoke standpoint. The proposition was rejected, although the company was at the same time professing to the Smoke Department that it was willing to do anything within reason to prevent the plant from violating the ordinance. Finally, after having been in Court a few times, the management instructed the chief engineer to hire a bricklayer who would be willing to work ten hours for \$2.00 per day, and a helper at \$1.50 per day for twelve hours. With this force, work was started on the reconstruction of the furnaces, after having obtained engineering advice from the Smoke Department. The work was supervised by the Department, and by the stoker manufacturer whose product happened to be used in the plant. The job was finally completed and the stack satisfactorily cleaned up.

The case illustrates the half-hearted way in which some owners attack the problem, and the reluctance with which they spend any money in trying to solve their difficulties.



CAN. FAIRBANKS MORSE CO., LIMITED.

THE Canadian Fairbanks-Morse Co. is out with its annual statement for 1912, showing net profits of \$390,303, to which is added that brought forward from 1911, \$307,615, giving a total of \$697,919. From this was paid dividends of \$177,114, leaving \$520,805.

On December 31, 1911, the company had outstanding \$323,400 of 7 per cent. preferred stock, and \$1,571,700 common. During the year, the 7 per cent. preferred stock was converted into 6 per cent. stock, and an additional amount sold, bringing the outstanding issue up to \$1,500,000. A further small amount of common stock was also disposed of, the amount authorized and outstanding, now being \$1,600,000.

The above figures, showing earnings of over four times the amount necessary to meet the sum of \$90,000 required for a full year's dividend on the preferred stock, is particularly satisfactory, as the additional money obtained from the above mentioned issues of further stock was available for only part of the year, and has not yet in fact become fully productive.

The general balance sheet shows the company to be in a strong financial position. Surplus and reserve funds now amount to \$667,487, and total assets, after deducting current liabilities, amount to \$3,767,487, of which \$2,918,583 was represented by liquid assets.

The value of good will, patents, patterns and drawings have been written down out of earnings at the nominal figure of \$1. It has always been the practice of the company to provide liberally for depreciations on buildings and equipment, a sum equal to 10 per cent. per annum of the original cost thereof being appropriated.



NEW MACHINERY HALL, TORONTO NATIONAL EXHIBITION.

G. E. MOORING, following the report of the members on the National Exhibition, said: "Why can we not have a better building for the machinery in the exhibition? We have machinery enough to fill three buildings the size of the old shed at present erected.

In reply, G. T. Irving stated that as soon as the switches were constructed into that region, a new building would be erected for the machinery exhibit. "The money, I think," he said, "has already been voted for it, and we are well aware of the unsatisfactory condition of the present structure."

Sectional Water Tube Boiler With Positive Circulation

The accompanying illustrated descriptive article deals with a new product of the old established, yet up-to-date and enterprising firm of Canadian manufacturers—The Goldie & McCulloch Co., Ltd., Galt, Ont., and the data furnished sets forth, we believe, this new unit of power plant equipment in an attractive and instructive light.

HITHERTO, all water tube boilers manufactured in Canada have been of the wrought steel header or water leg pattern, consisting of tube and handhole sheets, flanged, riveted and stayed together; the neck being shaped to fit the drum to which it is riveted. A large number of this class have been built by various firms, although differing in details according to the ideas of each designer, and, with a few exceptions, most of them have given good service.

Sectional Type Advantages.

The pattern, however, most generally favored and called for in the specifications of engineers, architects and other, is the sectional type, on account of its simplicity of design, absence of stayed surfaces, ease of transportation and general adaptability where other types cannot be used. It has, however, been long recognized by those conversant with this type of boiler, and in charge of plants where it is in daily operation, that there was room for improvement, particularly as regards the mode of circulation, and that by a modification in

Another, and very important point to be noted in connection with a boiler of this description, is that the use of cast metal is absolutely prohibited, a feature which has hitherto limited the extent of its manufacture, and in the boiler we are about to describe, it will be found that the headers, their fittings and cross-box are made throughout of forged steel, a new and specially designed plant having been laid down for the purpose by engineers experienced in this class of work. In this respect, the firm, we believe, takes the lead amongst the boiler-makers of Canada.

Before proceeding to describe and illustrate the boiler, we might add that the pattern is by no means experimental, large numbers being at work in France, Belgium and other European countries, differing mainly in details, the chief and most important of which is the form of header, this being in a number of cases made "straight," thereby rendering the boiler less efficient than with the staggered form, whilst the drums and other parts of the circulating system, being more restricted in area,

this class, differing chiefly in several essential points, in that it embodies distinct features designed to improve the circulation and steaming capacity, minimize the cost of repairs and maintenance, and, by directing a full supply of water to the point where most needed, keeps the generating tubes well supplied under all conditions. The boiler can, therefore, be forced to a large degree, without endangering in any way the safety of its constituent parts.

It is constructed entirely of best quality mild steel, and consists of a number of lap welded and seamless steel tubes varying according to the size and capacity of the boiler, arranged in sections, and connected at each end to a sinuous header in the manner so well-known with this class of boiler. The headers Fig. 2 are of forged steel, of extra large external area, and staggered so that the tubes of one row lie immediately over the space between the two tubes immediately beneath it. Into these headers, and on one side of them, the tubes are expanded, there being an opening on the other side opposite the end of each tube for cleaning and inspection purposes, the opening being oval in form and closed with a handhole plate "placed on the interior of the header and held in place by a forged steel bridging bar and bolt; the joint being made with, and not against the pressure, only a copper or asbestos joint ring is necessary.

The steam and water drums are made of large diameter, so as to provide liberal disengaging surface and increased storage capacity for the steam. At the front of each drum, and riveted to same, is a forged steel cross box made from the solid plate: this is connected to the front headers by nipples of extra large diameter, so as to facilitate the flow of steam and water from the headers to the drum, the enlarged size of header alone permitting of this arrangement. The larger nipples, with the easy curves of the header, promote, it is claimed, a more rapid and efficient circulation than in other boilers of its class.

At the rear of each drum, and connected to a wrought steel nozzle, is a large circular downtake pipe of lap-welded steel, which conveys the water of circulation direct to the bottom of the headers, both being connected to a cross drum of large capacity. By this means, a full and constant supply of water is delivered to the lower rows of generating tubes immediately over the

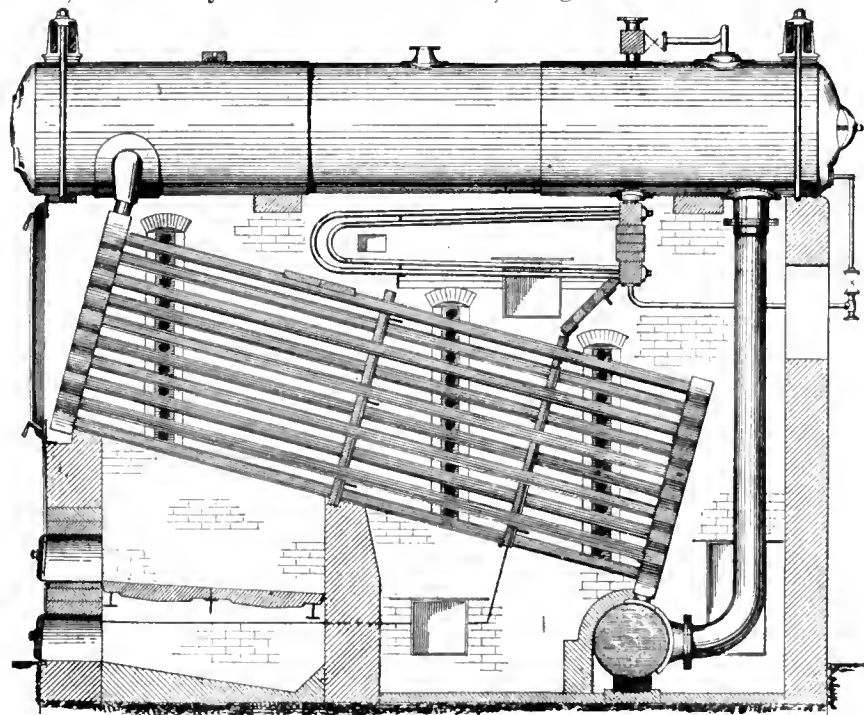

FIG. 1. GOLDIE & McCULLOCH STANDARD SECTIONAL WATER TUBE BOILER.

design, a much more efficient steam generator might be produced, which would not only increase its evaporative capacity, but at the same time eliminate the trouble experienced in connection with the lower rows of generating tubes.

tend to reduce their generative capacity more than with the pattern we are about to describe.

Standard Type Boiler.

The boiler as shown by Fig. 1, is somewhat similar to many others of

furnace, eliminating the troubles usually experienced due to over-heating, buckling and burning out of tubes. The cross drum as will be seen in the illustration is fixed at the lowest part of the boiler and in a position remote from the action of the fire. It is also so arranged as to receive all impurities deposited, the capacity per unit of length being twelve times that of the small square section tube generally used. The drum made of best quality steel plate, is fitted at one end with a manhole, and has also a solid weldless steel nozzle riveted for connection to each downtake pipe.

It will thus be seen that the circulation in this boiler is "positive," the water flowing continuously in one direction, every tube being brought into action instead of the circulation being short circuited in some tubes, and sluggish and even reversed in others, a fact not only known to users of the ordinary sectional boiler, but also emphasized in the "Stirling Book on Steam." In this new sectional boiler, however, there is little disposition to these conditions, the lower rows of tubes in which the greater part of the steam is generated, being fully supplied, and under the effects of rapid circulation are free from the danger of scaling which with an inadequate supply of water soon involves destruction of the tubes.

Another important improvement is in the spacing of the tube centres both horizontally and vertically, being greater than in other boilers of this class, while adding materially to the efficiency of the boiler and permitting of better mixing and combustion of the gases. Where boilers are fired with blast furnace gases, this arrangement of tubes will be found to be decidedly advantag-

eous, on account of the varying condition due to atmospheric and other changes in the process of smelting. It will also be found that the grate area per unit of length is greater than in any similar boiler, a point to be carefully noted when dealing with different grades of fuel. By the elimination of the small downtakes usually found at the rear of this class of boiler, the

pattern being particularly adapted for installation in office buildings and hotels, departmental stores and boiler rooms, generally, where the head room is limited or where a boiler or its parts have to be introduced through narrow passage ways and restricted openings. The headers are made of forged steel, and finished in the same manner as for the standard pattern. With the sole ex-



FIG. 2. FORGED STEEL HEADER.

gases have less retardation in their passage to the damper, and consequently a better draught is obtained throughout. The boiler is hung from a massive framing of rolled steel beams and channels, and is so designed as to permit of free expansion and contraction without any undue strain. The fittings and fixtures are all of the best design and manufacture in accordance with the latest practice.

Cross Drum Type Boiler.

Figure 3 illustrates the cross drum type of sectional water tube boiler, this

ception of position and mode of connecting the steam drum, the boiler possesses the same distinctive features as regards circulation, furnace capacity and general working qualities as the other type.

Generally, the boilers as above outlined and described may be considered as a decided and important advance in steam engineering practice and manufacture as far as Canada is concerned, and are sure to attract the attention and serious consideration of engineers and others interested in steam generation.

We understand that the makers are already receiving numerous enquiries for this boiler, and we hope shortly to be able to publish particulars and data as to its service performance.

Super-heater Equipment.

The super-heater equipment, supplied with these boilers when required, is shown in Fig. 1, and consists of two headers or manifolds which receive and deliver the steam respectively; connection being made by loops of solid drawn steel tubes with ends expanded into the headers. Provision is made for flooding the super-heaters during the steam raising period, and for drawing same thereafter. An equalizing pipe and valve are also supplied for regulating the temperature of the super-heated steam.

The Fred Thomson Co., Ltd., Montreal, Que., has been incorporated with a capital stock of \$100,000, to manufacture electrical machinery, supplies and accessories.

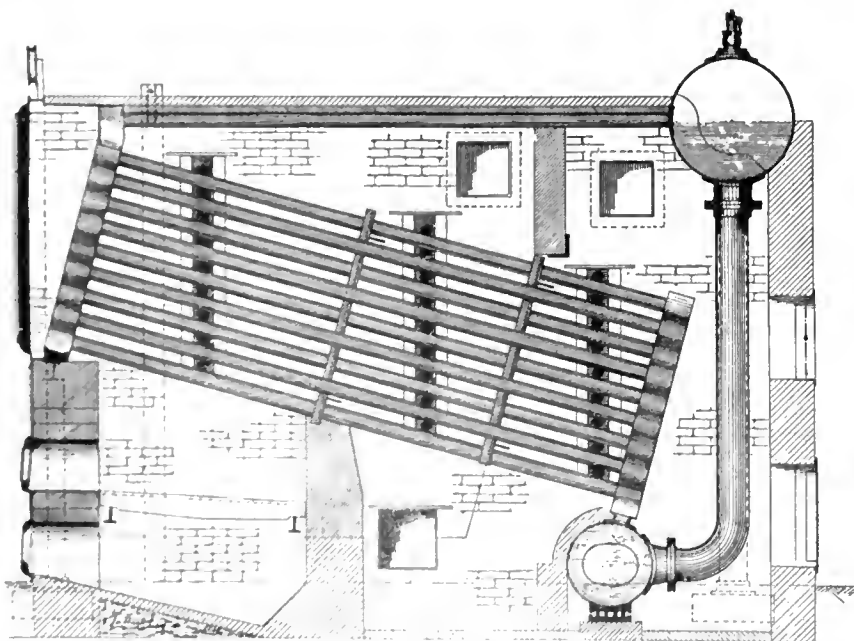

FIG. 3. GOLDIE & McCULLOCH CROSS DRUM SECTIONAL WATER TUBE BOILER.

Concerning Water Hammer and Resulting Explosions

Water hammer is more or less an accompaniment of every steam power plant, being more aggravated in its effect in some than in others. To counteract or minimize its effects in all cases, requires careful and skilful treatment by the engineer operator.

IN a British Board of Trade investigation into an explosion which occurred on board the R.M.S.P. Co.'s steamship "Araguaya," while she lay in dock at Southampton, through which three men were killed and several others severely injured, the Commissioners were unanimous in their conclusion that the explosion was due to water hammer. The explosion took place in a stop valve chest through the accidental opening of a drain cock. Only three days previously, the stop valve chest which failed had been tested hydraulically, under suitable supervision, to a pressure of over twice that at which it worked, the pressure being maintained for about an hour.

Conditions Favorable to Water Hammer.

P. J. Haler and A. H. Stuart, in an article appearing in the "Machine Tool Engineer," say that in view of the frequency of accidents of this type, it may be well to consider the various conditions which may lead to water-hammer action. The most readily understood example is that of a long line of pipe carrying water. If a valve in this line is suddenly closed, it is easily seen that this action is an attempt to bring to rest a great weight of water possessing considerable velocity. The energy must go somewhere and since the compressibility of water is extremely small it delivers a blow to the stop valve, which usually fails to withstand the shock.

Most serious accidents which arise through water-hammer action, however, occur in steam pipes, and for the action to be set up, the first condition is that water and steam be present in the pipe; but the mere presence of water and steam does not mean that water hammer will result. The extra conditions known to have prevailed in cases where explosions have occurred are:—

(1)—The example most closely allied to the hydraulic one mentioned above is that in which a plug of water has collected in a steam pipe. This may happen as a result of condensation of the steam, or it may be due to a boiler priming. When the engine stop valve is opened, the steam passing along the pipe will carry the plug of water with it. If the steam range is a long one, the water will acquire a considerable velocity as the engine gets up its speed, and when an elbow occurs in the pipe, as, for example, at a stop valve, the water possesses too much momentum to change its direction so rapidly, and a blow is

accordingly delivered to the side of the valve chest.

(2)—Suppose during the inactivity of an engine, steam has condensed, and the water so formed has collected in some low-lying portion of the steam range. It occasionally happens that the drain cock is opened while the range is under steam pressure. This operation will remove some of the water from a portion of the pipe which was probably full, and thus a long surface of comparatively cold water is exposed to steam in the upper part of the pipe. As a result, large quantities of steam are condensed, and the consequent inrush of steam will raise waves on the surface of the water, and these will isolate a quantity of steam from that which follows. This entrapped portion condensing, produces a vacuum, into which the water shoots with great violence, thereby delivering a water-hammer blow. In many cases, this shock is sufficient to fracture the pipe at the point where the blow is delivered, but in other cases the pressure wave is transmitted along the pipe to do damage elsewhere, usually at a blank end, where its force will be doubled by reflection.

(3)—Very similar to these conditions are cases in which steam has been admitted to pipes which contain water, and others in which water has been admitted to (as in over-heated economizers) or formed by condensation in (as in cold ranges) pipes containing steam.

(4)—Several examples are on record where water hammer has resulted from the opening of a valve when there has been steam pressure on both sides of it, and water on at least one side. This may happen where there is a main under steam pressure, and steam is being raised in a boiler which has been out of use.

(5)—In long and complicated systems of piping, cases are known where the flow of steam has dammed up water in unused portions of the range. A fall in the velocity of the steam would release this imprisoned water, and conditions similar to those mentioned in examples (1) or (2) might be produced.

Possible Precautions.

Summing up briefly, the possible precautions which may be taken to avoid water-hammer action, in the case of a single boiler and a single engine, the junction valve should be at the highest point of the range, and the steam conveyed to the engine along a horizontal

pipe. With two or more boilers, or two or more engines comes the danger of the flowing steam damming up water as in example (5). If a horizontal steam pipe rises after it leaves the boiler junction, the water may collect in the pocket, and if the pipe falls and then continues horizontally to the engine, water may collect near the engine stop valve. It is desirable that all pockets be fitted with water catchers having water gauges and automatic drains. Drain cocks on steam pipes, although a necessity, are a source of great danger, unless they are very carefully attended. If left partly open, they are liable to become choked, and if opened occasionally, they may produce the conditions set out in example (2).



SHOP VENTILATION AND DUST COLLECTION.

THE following orders have been issued by the Industrial Commission of Wisconsin:

Emery Wheels.

All grinding, buffing and polishing wheels, except those wheels where water is applied at the point of grinding, must be equipped with a hood. The hood must cover the wheel in such a manner that it will carry off the dust insofar as the character of the work will permit. On grinding, buffing or polishing wheels, 4 in. or less in width, the width of hood must be 6 in. On grinding, buffing or polishing wheels over 4 inches in width, the maximum width of hood must never be less than 2 inches or more than 3 in. wider than the width of the wheel.

The suction in the connection to the hood must be sufficient to displace a column of water in a U-tube, 5 inches. The test for suction with the U-tube must be static test, and must be made in the following manner: A hole $\frac{1}{8}$ -in. in diameter must be made in the suction pipe approximately 12 in. from the connection to the hood. The rubber hose attached to the U-tube must be placed over the $\frac{1}{8}$ -in. hole and the test made under these conditions. When the water in the U-tube stands at 0, the 5-in. displacement is secured when one column of water rises $2\frac{1}{2}$ in. above 0 and the other column of water falls $2\frac{1}{2}$ in. below 0.

All branch suction pipes must enter the main pipe in the direction of the flow of air, and at an angle not exceeding 45 degrees measured from a line parallel with the current of air in the main suction pipe. All bends, turns and elbows in suction and discharge pipes must be made with smooth interior surfaces, and the radius of the curvature of the elbows on such pipes, measured from the centre of the pipe, must not be less than twice the diameter of such elbows.

The dust discharged from any exhaust system must be taken care of by a dust collector, air washer or other adequate system which will prevent it from contaminating the air in or around the place of employment.

Sandblasts.

All sandblasting operations, not performed under an inclosed hood, must be performed in a special room set aside for that purpose. This room must be equipped with an exhaust system which shall change the air in the room not less than four times per minute. The employer must furnish the employees who are working in sandblasts rooms with a suitable covering for the face, which will protect the eyes, nose and mouth; such protector should be worn by the employee when working in the sandblast room. All tumbling barrels and rattlers must be equipped with an exhaust system, which will remove all particles of dust which are light enough to float in the air. All machines which create and throw off dust sufficiently light to float in the air, must be equipped with an exhaust system so designed and attached that it will carry off the dust in-so-far as the character of the work will permit.

Forges, Foundries, Etc.

All furnaces and forges which emit gas or smoke in such quantity as to be irritating, obnoxious, or injurious to health, must be equipped with a ventilating system which will remove as much of the gas and smoke as the character of the work will permit. In all places of employment, where the heat or humidity, as a result of the work done, is such as to be injurious to health, a means of ventilation must be provided which will reduce the heat or humidity to as reasonable a degree as the nature of the work will permit. Where the air is so dry that it is injurious to the health, it must be properly humidified.

All foundries, forge shops, round-houses and other places of employment in which smoke, gas, dust or vapor are present in sufficient quantities to obstruct the vision, or to be irritating, obnoxious, or injurious to the health, must be equipped with a system of ventilation which will eliminate such smoke, gas, dust or vapors, in-so-far as the conditions of the industry will permit. Such system of ventilation must change the air in the room not less than twice each hour, and must supply the room with an additional amount of air to make up for the loss of oxygen which is consumed by the fires. Each person in the room must be supplied with not less than 1,800 cu. ft. of fresh air per hour. The above standard of ventilation for foundries and forge shops can be secured with proper window space on the sides,

sufficient height of roof, and with adequate lantern provisions in the roof.

Cubic Feet of Air Required.

All rooms in places of employment where there is less than 900 and more than 300 cu. ft. of air space per person, and in which there is no smoke, gas, fumes, dust, vapor, or fires consuming oxygen, must be provided with a ventilating system which will furnish 1,800 cu. ft. of fresh air per hour to each person. In all rooms which consume oxygen, an additional amount of air must be supplied to make up the loss of oxygen.

All rooms in places of employment where there is 900 cu. ft. of air space per employe, and in which there is no smoke, gas, fumes, dust, vapor, or fires which consume oxygen, must be provided with a ventilating system which will change the air in the room not less than twice each hour. Such system must be so designed as not to produce injurious drafts or reduce the temperature materially below the average temperature maintained.

It has been found that in rooms where the employees are engaged in active work a temperature of 60 to 65 deg. is the best standard to maintain. In this temperature the men are invigorated and are less likely to catch cold when they go out of doors. In rooms where the employees are engaged in sedentary occupations, it has been found that a minimum temperature of 68 deg. is advisable.

In all places of employment not less than 300 cu. ft. of air space must be provided for each person.

KEEPING THE SHAFTING IN LINE.

By C. R. Trowbridge

WHEN a line shaft is originally erected, it is presumably straight and true, and the hangers and bearings by which it is supported are, or should be accurately aligned and firmly secured. It is unfortunately true, however, that few such installations are permitted to remain in the correct relations in which they have been placed. Variations in loading upon floors, settlement of piers, unequal belt stresses, burden of pulleys and especially frequent disconnections and reconnections, combine to affect the truth of the whole and to prevent it from keeping in line. Under such circumstances, it is essential that the properly designed transmission system should include ample opportunity for self-adjustment and for local correction.

The fundamental requirement of a satisfactory journal bearing is that it shall be truly in line with the shaft itself. This includes some form of freedom of movement, such as is given by a ball-and-socket support, permitting a small

amount of oscillation in any direction to conform to the direction of the axis of the shaft. Such an adjustment is recognized as an essential to every well designed hanger; but too often it consists merely of a sort of looseness which permits wobbling in any way, and does not provide really proper support. A true ball-and-socket unites firmness with adaptability and is self-adjusting, so far as variation in direction is concerned.

There is another set of adjustments, however, which demands individual attention, but which should be capable of being effected easily and accurately. These adjustments provide for the bodily movement of the bearing, both vertically and laterally, to conform to any actual shifting in position of either shaft or hanger. With such adjustments, capable of correcting for any change of position and yet free, independent and unintentional shifting, the problem of keeping the shaft in line becomes simplified to an extent which renders excessive friction losses inexcusable.

The question of lubrication has been met in a number of ways, and the so-called self-lubricating bearings require so little attention that this point may be considered as wholly solved.—Iron Age.



THE FUNCTIONS OF THE TECHNICAL COLLEGE.

By Henry Taylor.

THE idea has recently been put forward that technical colleges should be encouraged to carry out work for manufacturing firms, such work to be done by the college students with the help of an expert staff of workmen. The proper function of the college is to teach the principles which underlie the practice of any trade or profession. No college can turn out men competent to take up responsible positions in commercial firms, and should not attempt to do so. It should aim at training a student's mind, so that, at the conclusion of his college career, he will be able to start his active career in an intelligent manner.

If the college is to carry through work under commercial conditions, there will be no time to explain why a certain process is followed in one case, and another process in another case; if the conditions are commercial, the object must be to push the work through with all expedition, and the students would thus have to do the laboring and waiting on. The expert workmen would have to work hard to keep up the production of quantity in the necessary time. Any arrangement whereby the quantity of work taken is restricted to that easily managed by the staff of expert workmen and students and to allow time for the reasons at the back of each process

being explained, immediately makes the conditions other than commercial. Then, the students must be in at 7 a.m. and work till 6 p.m., and be under the care of a foreman having liberty of expression and disciplinary powers.

Wrong Attitude Apparent

The whole attitude of the technical colleges to the trade is wrong. Time after time I have come across disappointed youths and parents who complain that they were led to send their sons to a technical college from the statements made by the college authorities that there would be no need for the youth to go through the dirty and unpleasant ordeal of the shops if he took the prescribed course at the college, and that he would on the completion of his career as a student be able to obtain a well-paid appointment on the staff of some firm. In the majority of these cases, the youths never settle down to work in earnest, and seem incapable of understanding that to succeed in gaining a leading position requires years of routine work, well and faithfully done. If the staffs of the technical colleges laid it down to the students that the hard, dirty portion of the work must be faced properly and cheerfully, and that they as technically trained men had an immense advantage in starting their shop career with their minds trained to trace out the reasons underlying various processes, the matter would be entirely different.

Even then, however, the method of sending a youth to college before going into the works is a mistake. The plea that the youth, still has the habit of study is not worth anything, as this habit can be kept up at the evening technical school. Whilst the studious youth will require no urging to keep up his studies, the fact must be admitted that at the age when most youths enter a technical college they are not fit to have the full liberty which the colleges permit. They have just come from a tight discipline at the school at which they received their general education, and to the majority of them the freedom allowed is too tempting, and time is wasted. I can take anyone to-day to a certain billiard saloon near a technical college at which students can be found all through the working day idling when they should be attending lectures or demonstrations.

Another point often urged in favor of sending the boy to a college first is that he does not come in contact with the coarse jokes and language of the workmen at so early and so impressionable an age. The idea is founded on the fallacy that the conversation and habits at the college are unimpeachable. I have been a day student as well as an evening student at technical colleges,

and from experience know that this idea is utterly wrong. I had heard a good deal of undesirable language and interesting tales at the grammar school before going into the works, and was for a considerable time repulsed from certain workmen by their abominable and lewd conversation. After serving my time and gaining some further experience I proceeded to a technical institution to study as a day student for one year in the branch of engineering in which I intended to specialize. The time wasted by the majority of the students was appalling, and was looked upon by the teaching staff as "Well, it's their own fault, and their own loss." There was a set who regularly frequented a certain first-class bar and considered it due to their personal credit to "down" so many drinks at each sitting, whilst some of the tales and language would have done credit to a forecastle.

Now, when this sort of thing is presented by one's social equals, it is put in a much wittier and more delicate manner than in the workshop, and instead of repulsing by its crudeness, appeals to the sense of humor. The poison is there, and coming in a more attractive guise is ten times more subtle. On one occasion I mentioned this point to a professor in another college to that which I attended, and was met with the remark, "Oh, I don't think so; we have a very decent set of young fellows, and I have never heard anything of the sort." This man was greatly surprised when I asked him if he expected that they would allow him to hear this sort of thing. This opinion only showed how very far away from the real state of things the professor was.

I readily acknowledge the help received from technical training, and wish in no way to deprecate such training; but I do strongly oppose the idea of the colleges attempting to persuade people that their training is a substitute for the works training or able to equip a man in three years for a responsible position. The correct function of the colleges is to teach the underlying principles of the trade, and also the fact that to succeed, hard and monotonous work must be cheerfully faced at first.—Machine Tool Engineer.



Foreman Banquetted.—The office staff and employees of the Vulcan Iron Works, New Westminster, B.C., to the number of thirty, united on Saturday, June 7, in paying a tribute to H. Moran, foreman of the shops, on the occasion of his departure on a trip to Australia. The men presented him with a gold watch and a travelling grip. The manager of the works, J. R. Duncan, presided at the dinner.



Toronto.—The Gutta Percha Rubber Co. came in for censure at the hands of a jury under Coroner Clendenan at the morgue recently for allowing Joseph Webb, a man 73 years of age, to be in charge of an elevator without any previous experience. The second day that Webb had been running the elevator he was killed. The jury declared that "a younger and more experienced man" should have been in charge. Evidence was given showing that Webb had been bringing a load of hose from the third to the ground floor when the car went a short distance below it. He then sent the elevator up a few feet above the floor, but was unable to bring it down again and got in the pit underneath it to pull on the cable. This resulted in the car coming down on top of him and inflicting fatal injuries.

Toronto.—The appeal of the Imperial Loan and Investment Co., Limited, from the decision of Mr. Justice Clute, awarding W. S. McBrayne \$3,750 commission for the sale of the Jackson-Tilden Typewriter Co. plant and premises at Hamilton has been dismissed by the Appellate Division in a judgment given at Osgoode Hall. The defendants came into possession of the premises as mortgagees, and the court held that McBrayne was entitled to commission at five per cent. on the sale to the Schaaet Motor Car Co., of Cincinnati.

Thorold.—Claiming that the effluent from chemicals killed several of his cows, and that the chemicals from the smoke stack caused him to have had dreams and forced him to deprive himself of proper ventilation, John W. Shriner, of Thorold, has commenced a high court action against the Coniagas Smelting Co. for an injunction and for damages. W. A. Logie, of Hamilton, is acting for the plaintiff, who resides on the outskirts of Thorold. Near his land is the plant of the defendant company. A stream which runs through his land is utilized by the company for carrying off refuse from chemicals. The cows, he claims, drank the water and died. The plaintiff also claims that the smoke from the chimney entered his home, causing inconvenience and endangering his health. He has asked for an injunction to restrain the company from using the stream for dumping purposes, and also one to have the company remedy the smoke nuisance. He estimates his damages at \$1,000.

The MacLean Publishing Company

LIMITED

(ESTABLISHED 1888.)

JOHN BAYNE MACLEAN - - - - - President
H. T. HUNTER - - - - - General Manager

PUBLISHERS OF

CANADIAN MACHINERY

AND MANUFACTURING NEWS

A weekly newspaper devoted to machinery and manufacturing interests, mechanical and electrical trades, the foundry, technical progress, construction and improvement.

H. V. TYRRELL - - - - - Business Manager

PETER BAIN, M.E. - - - - - Edifoc.

C. W. BYERS - - - - - Associate

A. G. WEBSTER - - - - - Editors

OFFICES:

CANADA

Montreal, Rooms 701-702 Eastern Townships Bank Bldg.

Toronto, 143-149 University Ave., Phone Main 7324

Winnipeg, 34 Royal Bank Bldg., Phone Garry 2313

Vancouver, H. Hodgson, 2640 Third Ave. West.

GREAT BRITAIN

London, 88 Fleet Street, E.C. Phone Central 12960
E. J. Dodd

UNITED STATES

New York, R. B. Huestis, 115 Broadway, New York, N. Y., Phone 2209 Rector

Chicago, A. H. Byrne Room 607, Marquette Bldg., 140 S. Dearborn St., Chicago

CABLE ADDRESS:

Macpnbc, Toronto. Atabek, London, Eng.

SUBSCRIPTION RATE:

Canada, \$2.00; United States, \$2.50; Great Britain, Australia and other colonies, 8s. 6d. per year; other countries, \$3.00. Advertising rates on request.

Subscribers who are not receiving their paper regularly will confer a favor on us by letting us know. We should be notified at once of any change in address, giving both old and new.

Vol. IX. JUNE 19, 1913 No. 22

PRINCIPAL CONTENTS.

Plant of the National Steel Car Co., Ltd., Hamilton, Ont. 639-643

Electric Motors and Mice 643

Features of a Canadian Quick Revolution Steam Engine. 644-648

Chief Inspector of Boilers, Ontario Province 648

Some Essentials to Success in Machine Shop Practice. 649-650

Old Highlands Bridge Being Replaced 650

C. P. R. Construction 650

Educating the Public in Methods of Preventing Smoke. 651-652

Canadian Fairbanks-Morse Co. 652

New Machinery Hall, Toronto National Exhibition. 652

Sectional Water Tube Boiler with Positive Circulation. 653-654

Concerning Water Hammer and Resulting Explosions. 655

Shop Ventilation and Dust Collection 655-656

Keeping the Shafting in Line 656

The Functions of the Technical College 656-657

Recent Judicial Decisions 657

Editorial 658

Industrial and Construction News 659-662

Engineering ... Possible Equipment Requirements.

Electrical ... Waterworks ... Municipal ... Building

Notes ... Woodworking ... General Industrial ...

Railways ... Bridges ... Contracts Awarded ...

Tenders ... Marine ... New Incorporations ...

Personal ... Oblituary ... Trade Gossip.

Selected Market Quotations 663-661

The General Market Conditions and Tendencies 664

CANADIAN PLANTS AND PRODUCTS.

IN the present issue of Canadian Machinery, considerable space is devoted to a racy description of the plant and product of the National Steel Car Co., Ltd., Hamilton, Ont., and to two products of the old established and well known firm of Goldie & McCulloch, Galt, Ont. Concern-

ing the first of these, no more assuring sign of the prosperity, progress and development of this Dominion, in the broadest sense, need be sought, for the fact that our railroads find it impossible to secure equipment and rolling stock delivery at home, in order to keep pace with their requirements is of itself unquestionable evidence.

The layout, erection and equipment of such a plant as that of the National Steel Car Co. are features which forcibly appeal to many subscribers and to advertisers in this journal, because of the opportunities afforded on the one hand of learning something relative to a car plant and its product, and on the other hand of bringing to the notice of builders of machinery specially designed for this work, the many openings for the disposal of their wares, which each few months' interval brings to the front. The machine tool equipment of a car building plant, differs in no respect from that required for the manufacture of any other specialty, it being, as we would expect in these days of keen competition, the latest and most up-to-date.

Reference is also made in this number to the establishment of a mammoth steel plant, on the opposite bank of the St. Lawrence, from Montreal, and, here, as in the case of the National Steel Car Co., installation, but on a much larger scale, light, heavy, delicate and powerful machinery will be required in order to accomplish the purposes of the promoters.

In the case of the Goldie & McCulloch products already referred to, and particularly that of the enclosed, vertical, quick revolution, forced lubrication, steam engine, a rather different machine tool equipment is a works requirement, from that installed in a car building or steel plant. Might we say that machines of a finer grade build, and of higher degree precision, are a necessity for this class of work; and in so expressing ourselves, do we not simply widen the scope available to machine tool builders for an unlimited variety of product. The building of this type of engine, as well as that of high grade water tube boilers by Canadian manufacturers is evidence of a demand for these specialties, and of confidence that the future will see that demand still further increase. Be it noted that, the introduction of these lines, or in fact, the great majority of new manufacturing features introduced in recent years, does not displace, or at any rate, and only in few cases, existing manufactured products, hence, it is, that but larger opportunity is afforded the machine tool builder, who is alert and who is keeping abreast of the times.

We believe that much misconception exists regarding the position held by Canada as a general manufacturing and industrial country, and that more or less ignorance is prevalent among those who are in a position to cater to her needs, with respect to what these are. We do not profess, as yet, to manufacture any line to the full extent of our requirements, besides, we believe, that even if we did, a monopoly of the best of everything would not be ours. We are alert, however, and ready to take advantage always of the best offering, and in the machine tool as in other lines, we make no exception. Our own engineering establishments and their high attainment are the result of outside competition, and we are in the game for "keeps," believing it to be a necessity for advancement and achievement in the future.

INDUSTRIAL ^{AND} CONSTRUCTION NEWS

Establishment or Enlargement of Factories, Mills, Power Plants, Etc.; Construction of Railways, Bridges, Etc.; Municipal Undertakings; Mining News.

Engineering

St. Catharines, Ont.—An addition is being made to the plant of the Steel and Radiation Co., Ltd.

St. Catharines, Ont.—The Canadian Warren Axe and Tool Co., Ltd., are building a new plant for the manufacture of logging axes, etc.

Port Robinson, Ont.—The Standard Steel Construction Co., Ltd., are building a factory, costing \$75,000, for the manufacture of structural steel.

Welland, Ont.—The Canadian Billings and Spencer Co., Ltd., are increasing their plant at a cost of \$35,000, to enable them to make drop forgings up to 200 lbs.

Quebec, Que.—It is not yet settled whether the Transcontinental shops will be located at St. Malo or at Cap Rouge. Capt. W. J. Press, mechanical engineer for the N.T.R. and his assistant, Mr. D. T. Evans, arrived at St. Malo last

week to test the stability of the site proposed. Their decision will be known in a week.

Thorold, Ont.—W. H. McIntyre, of Appleton, Wis., who is stopping at the Grand Central, St. Catharines, intends to start a machine shop and foundry in the Dobbie foundry.

Goderich, Ont.—The ratepayers having voted favorably on a by-law, the Rice-Knight Co. will build a plant costing \$42,000 for the manufacture of electric fittings. Tenders to be called in August.

Ayr, Ont.—The gas plant of the John Watson Mfg. Co., exploded on June 13th, injuring several employees in the moulding department, and destroying the gas plant.

Dundas, Ont.—The Canadian Abrasive Wheels, Ltd., have purchased a site of eight acres and will erect buildings at a cost of not less than \$20,000, the town to guarantee its bonds to the extent of \$15,000.

Montreal, Que.—The Canadian Stove and Furniture Co. Ltd., will build a stove foundry at a cost of \$75,000, in St. Laurent. Architect W. A. Mahoney, Guelph, Ont.

Lindsay, Ont.—The Canadian Boving Co., manufacturers of hydraulic machinery, who purchased the Madison-Williams Co.'s plant some weeks ago, are preparing to extend it, and have asked the Board of Water Works Commissioners to extend the service to their plant for use in toilet rooms, and throughout the plant.

N.T.R. Shops for St. Malo.—In a letter to the Mayor of Quebec, Major Leonard, National Transcontinental Commissioner, states that the location and building of the Transcontinental Railway works shops at St. Malo, and a union passenger station at the Palais Ward, have been ratified by the Government. Major Leonard says the work will begin at once, both at the Palais and at St. Malo. The Union station will cost \$1,750,000, and the workshops \$1,500,000.

POSSIBLE EQUIPMENT REQUIREMENTS

The following is a list of firms who are, or are likely to be in the market for new equipment or material. For further details, reference should be made to the news items.

Machine Tools.

Steel and Radiation Co., Ltd., St. Catharines, Ont.

The Canadian Warren Axe and Tool Co., Ltd., St. Catharines, Ont.

The Standard Steel Construction Co., Ltd., Port Robinson, Ont.

The Canadian Billings and Spencer Co., Ltd., Welland, Ont.

Pilkington Bros., Thorold, Ont.

W. H. McIntyre, St. Catharines, Ont.

Canadian Abrasive Wheels, Ltd., Dundas, Ont.

The Rice and Knight Co., Goderich, Ont.

Woodworking Tools.

The Scotstown Mfg. Co., Scotstown, Que.

The Kingston Floor and Wall Tile Co., Kingston, Ont.

The Reliance Moulding Co., Kingston, Ont.

W. H. McIntyre, Central Hotel, St. Catharines, Ont.

The Canada Western Lumber Co., New Westminster, B.C.

The Edmonton Art Glass and Mirror Co., Edmonton, Alta.

Messrs. Willard and Sons, Maissonville, Que.

The Big River Lumber Co., Prince Albert, Sask.

Foundry Supplies.

The Canadian Stove and Furniture Co., Ltd., Montreal, Que.

Dunbar and Co., Woodstock, Ont.

Electrical Equipment.

Benedict College Trustees, Calgary, Alta.

La Societe d' Eclairage et d' Energie Electrique du Saguenay, Chicoutimi, Que.

The Town Council, Prince Albert, Sask.

The City Council, Battleford, Sask.

The St. Thomas Biscuit Co., St. Thomas, Ont.

The Atlas Power Co., Ashcroft, B.C.

The Casey-Cobalt Mines, Cobalt, Ont.

The City Council, Kingston, Ont.

Laundry Machinery.

Benedict College Trustees, Calgary, Alta.

Mining Machinery.

Casey-Cobalt Mines, Cobalt, Ont.

Turbine Pumps.

Board of Control, Winnipeg, Man.

Incinerators.

The City Council, Peterboro', Ont.

Motor Trucks.

The Works Department, Hamilton, Ont.

Refrigeration Machinery.

A. and R. Loggie, Loggieville, N.B.

Montreal, Que.—Announcement was made some weeks ago of the formation of the Steel Products Co., of Canada, Ltd., being a merger of several spring and axle companies, giving the names of the chief directors. Following is the remainder of the list: W. M. Byers, director Gananoque Spring & Axle Co., Ltd.; D. Ford Jones, managing director D. F. Jones Mfg. Co., Ltd.; W. E. Brough, of Richardson & Co., Montreal; Frank P. Jones, director Canadian Bank of Commerce, director Montreal Trust Co., managing director Canada Cement Co.; Fred Baou, of Bacon Bros., Montreal; Newbold C. Jones, Physician, Toronto; Norman F. Nash, of Richardson & Co., Montreal.

Electrical

Battleford, Sask.—Machinery for the Battleford power station has not yet been purchased.

Lindsay, Ont.—The Seymour Electric Power Co., Toronto, will instal a magnetite system of street lighting here.

St. Thomas, Ont.—The St. Thomas Biscuit Co. will instal 150 h.p. in motor capacity, and other auxiliary equipment.

Sarnia, Ont.—The Mackenzie Electric Co. are putting the finishing touches to the generators and switchboard at the new plant of the Mueller Mfg. Co.

Kingston, Ont.—The city has decided to spend \$34,000 for placing conduits on Princess and King Streets, and to remove overhead poles and wires.

Chase, B.C.—The Adams River Lumber Co., are installing an additional 60 k.w., 1,000 volt generator, made by the United Electric Improvement Co., Philadelphia.

Chatham, Ont.—The Hydro-Electric Commission engineers and construction men are here preparing to build a transmission line. The by-law will shortly be drafted.

Calgary, Alta.—Laundry machinery, water supply and lighting system and septic tank will be required for a new college which is being erected at a cost of \$53,000 for St. Benedict College trustees.

Prince Albert, Sask.—The town will erect a steam generating station, with steam turbines, connected to a.e. alternators, 200 k.w. each; also 5,000 h.p. boilers, with mechanical stoker. C. O. Davidson, clerk.

Cobalt, Ont.—The recent developments at the Casey Cobalt Mine, have exposed so much ore that the directors have decided to increase the capacity of the concentrator from 25 to 75 tons per day, instead of 50 tons as contemplated, and to install electric power.

Winnipeg, Man.—The city is considering electrification of the whole equipment in its pump house. At present gas engines are being used, gas being supplied by a producer plant. The latter in future will be used only as a standby. The whole, it is estimated, will cost \$50,000. It has also been recommended that the gas plant be done away with.

Chicoutimi, Que.—Incorporation has been granted to La Societe d'Elclairage et d'Energie Electrique du Saguenay, with a capital of a million dollars, to supply electric power and artificial and natural gas to the districts of Roberval, Chicoutimi, Saguenay, Three Rivers, Rimouski, Gaspé, etc., with headquarters at Chicoutimi. Among the incorporators are Julien E. A. Dubuc, Francois Xavier Gosselin and others, of Chicoutimi.

Water Works

St. John, N.B.—The city will lay two miles of new water main and the same length of sewers. The water mains are being shipped from England.

Berlin, Ont.—A concrete reservoir, costing \$16,000, with a capacity of 1,000,000 gallons, which is part of a \$100,000 extension to the waterworks plant, is nearing completion.

Port Coquitlam, B.C.—Tenders will be called by the council for the ditching, piping and supplies in connection with the Maillardville water scheme in the near future.

Esquimaux, B.C.—Plans and estimates for the proposed sewerage system for Esquimaux prepared by C. H. Topp show that it will cost in the neighborhood of \$385,000.

Tofield, Alta.—The municipality is installing the first unit of a first-class waterworks system. Water mains are being laid from the reservoir for fire protection only. Maxwell and MacKenzie are the town's consulting engineers.

Municipal

Hamilton, Ont.—The City Department of Works will probably be in the market shortly for two motor trucks.

Kerrisdale, Point Grey, B.C.—The municipal council have voted \$74,946 for the purchase of a site, and the erection of an incinerator. The by-law will be voted on June 21st.

Trenton, Ont.—Two money by-laws have carried—one to extend the sewerage system, and the other to pave Front and Dundas Streets, at a cost of \$75,000.

Peterboro, Ont.—The city is in the market for a \$10,000 incinerator. Last week A. H. Reid, representing the Reid Incinerator Co., of Toronto, made an offer to the Property Committee. His plant is guaranteed to handle 20 tons of refuse a day. A building 30 x 30 feet will be required. The matter will be settled this week.

Building Notes

Ottawa, Ont.—The Public Works architects have begun the preparation of plans for the Rideau Hall improvements. A new front of four or five storeys, with an imposing tower, is planned. The cost will be about \$150,000.

Winnipeg, Man.—The Olympia Co., Ltd., have taken out a permit for the erection of a nine-storey office and store building this summer, at a cost of about \$400,000. J. Chisolm & Son, architects.

Vancouver, B.C.—The Franco-Canadian Credit Foncier Co., is having plans prepared for a building, 50 x 120 feet, 10 stories, to cost \$334,000. H. L. Stevens & Co., 119 Pender Street West, Vancouver, architects.

Edmonton, Alta.—N. W. Purcell and G. W. Kelly will erect a wholesale warehouse on Fourth St., costing \$110,000, five storeys high. It will be of mill construction, red pressed brick, and ornamental stone trimmings.

Wood-Working

Biscoe, Ont.—A fire on Friday, June 15th, completely destroyed the lumber mill of Messrs. Booth and Shanuan.

Sutton, Que.—The plant of the Vencer Mill Co. was destroyed by fire on June 7th, at a loss of \$175,000.

Kingston, Ont.—The city has agreed to give bonuses to the Kingston Floor and Wall Tile Co., and to the Reliance Moulding Co.

New Westminster, B.C.—The Canada Western Lumber Co., at Fraser Mills, B.C., will build a veneering plant, costing \$5,000, and employ 50 men.

Toronto, Ont.—Fire broke out in the construction shop of the Marine Construction Co., York Street, June 11th, doing damage to the extent of \$7,000.

Prince Albert, Sask.—The Big River Lumber Mill, ten miles north of Prince Albert, was destroyed by fire June 11th, at a loss of \$500,000. The capacity of the mill was 600,000 ft. per day.

Maisonville, Que.—The last block factory of Messrs. Willard and Sons at McNeills Corner, was destroyed by fire on June 12th, together with machinery and contents, putting 30 men out of employment.

New Westminster, B.C.—D. E. Campbell, who purchased \$225,000 worth of timber across the Fraser River from the B.C. Mills Timber and Trading Co., will log the timber for a party who will erect a mill there.

Scotstown, Que.—The Scotstown Manufacturing Co., manufacturers of chairs, will shortly apply for a Dominion charter, with a capital of \$50,000. A. M. McKenzie, F. G. Roy, N. G. Scott, Scotstown, are among the directors. The new plant is now being built.

North Vancouver, B.C.—The North Vancouver Lumber Co., corner of Esplanade and St. George's Avenue, are making improvements, costing \$15,000, at their sash and door factory. They are installing a steam heating system for the dry kiln and a large boiler. J. McAllister is the proprietor.

Hamilton, Ont.—The Parkes Construction Co., near Tonawanda, N.Y. will build a branch plant here. They will fabricate greenhouses, conservatories, sun parlors, and light steel structures, as well as manufacture ventilating machinery, iron and wood benches, and heating apparatus. F. W. Parke is manager, with offices at 167½ King St. E.

General Industrial

Redcliffe, Alta.—The Alberta Shoe Co. will build a factory here, costing \$75,000. Manager, F. C. Young.

Niagara Falls, Ont.—The American Cyanamid Co. will extend their plant this summer at a cost of \$500,000.

Fort William, Ont.—Messrs. Davidson & Smith will build a flour mill of capacity 3,000 bbls. a day, if given certain concessions by the town.

Loggieville, N.B.—The lobster factory, cold storage warehouse and fish-encasing equipment of A. and R. Loggie was destroyed by fire June 5th.

Thorold, Ont.—The first sod for the large glass works of Pilkington Bros., of St. Helens, Eng., was turned on Friday, June 6th. R. F. Taylor is resident manager.

Vancouver, B.C.—The Inland Coal and Coke Co., Nicola, near Nerritt, is about to increase its output from 500 to 1,000 tons per day. Joseph Graham, general manager.

Quebec, Que.—Contractors for building the great highway between Quebec and Montreal, are purchasing machinery, and will start in earnest in a few days at both ends of the line.

Aylmer, Ont.—Machinery for the new plant of the Dominion Cannery is now being installed to be in readiness for this year's crop of vegetables. It will be operated throughout by electricity.

Fort William, Ont.—The Grain Growers Grain Co., Ltd., have purchased the Davidson & Smith elevator and bagging plant at Hardesty St., for \$140,000. R. B. Henderson will have charge.

Charlottetown, P.E.I.—The Colonial Corporations, Ltd., of Halifax, have offered to form a company, known as the P.E.I. Cereal Co., and will build a mill, elevator, etc., here, costing \$100,000, if provided with a site.

Lillooet, B.C.—Metallurgists have examined the ore from the Broken Hill property at Bridge River, and report favorably. Should plans materialize, the property will be heavily capitalized, and an oil smelter installed.

Thorold, Ont.—The MacCormack interests, who are completing a new two-machine newspaper mill at Thorold, Ont., have decided to build a 75 ton sulphite mill immediately. Warren Curtis, Jr., is the manager at Thorold.

Fort William, Ont.—Excavations for a cleaning and drying elevator for D. H. Dwyer & Co., on Island No. 2, have commenced. It will be ready to handle new crop by September, and will cost \$75,000.

Toronto, Ont.—The Tannery and Leather Factory of Wickett & Craig was destroyed by fire on Monday night, June 16th. The loss, which amounts to \$500,000, is fairly well covered by insurance.

Hamilton, Ont.—The National Gas Co. have come to terms with the city council, and will go ahead with their plant. They will supply coke gas to the city at 40 cents per 1,000 feet. R. F. Miller is managing director.

Edmonton, Alta.—The Edmonton Art Glass and Mirror Co. are building a factory with 4,000 feet floor space, for the manufacture of mirrors, art, etched and bevelled glass. D. L. Inland, of Los Angeles, Cal., is interested.

Hawkesbury, Ont.—The Riordan Pulp and Paper Co., who have mills here and at Merriton, will build a sulphite mill in Northern Ontario next spring, with a capacity of 30,000 tons. The company's agents have been busy in New Liskeard, Haileybury and North Timiskaming, and have option on land in the second town.

Vancouver, B.C.—Vancouver and Victoria capitalists, headed by James A. McNair, who has acquired the oil properties of the Amalgamated Development Co. at Controller Bay, Alaska, will carry on a vigorous policy of development. The output of the refinery will be increased to 250 barrels daily, and equipment for saving by-products will be installed. Mackenzie & Mann, Toronto, are interested.

Railways—Bridges

Port Moody, B.C.—The British Columbia Railway Co. are prepared to run a tramway line between Port Dalhousie and New Westminster.

Sherbrooke, Que.—It is understood that the Canadian Pacific Railway Co. are preparing plans for an electric railway between Lennoxville and Coaticook, at an estimated cost of \$500,000.

Toronto, Ont.—The C. P. R. have applied to the Dominion Railway Board for approval of a plan for an additional track from Queen Street to Royce Avenue.

Vancouver, B.C.—The organization of the Burrard Inlet Tunnel and Bridge Co. was completed June 5th by the election of directors, representing the different municipalities. F. Carter-Cotton was elected president.

Vancouver, B.C.—The firm of Sir John Wolfe Barry has been appointed consulting engineers for the construction of the Burrard Inlet Tunnel and Bridge Co., and will have plans prepared in six weeks time, when tenders for construction will be called for.

Saskatoon, Sask.—The Atlin Railway Co. will be incorporated by the Dominion Parliament next session to build a line from Atlin to the international boundary. The Naas Valley and Northern Railway Co. is another line which will build considerable trackage in Saskatchewan.

Halifax, N.S.—The work of removing some of the properties at the south end of the city for the new terminals has begun.

Winnipeg, Man.—A start is being made on the new local terminal facilities of the C.P.R. The Westinghouse Church Kerr Co. has obtained the contract for the work. Efforts will be made to have the improvements finished inside two years, and the cost will be approximately a million and a half dollars.

Toronto, Ont.—The C.N.R. has submitted a plan to the C.P.R. and G.T.R. for the erection of a union station, to be built on the west side of the Don River and just north of Queen street, Toronto. This would cost approximately a million dollars. Should the Grand Trunk be willing to go in with the other two roads on the project, it would save that railway the difficulty it now faces with its Queen street level crossing, as it would mean that all three railways would enter the city from the east over the one trackage, consisting of four parallel tracks.

Contracts Awarded

Tofield, Alta.—The town has placed an order for a 100 h.p. steam boiler through E. Leonard & Sons, of Calgary, to supply steam for the pumping plant.

Saskatoon, Sask.—The Council has awarded the contract for supply of steel for street railway extensions to the Canadian Steel Foundries, Limited.

Victoria, B.C.—The contract for installing a patent lock system in the new Provincial Jail, which is now under construction on the Wilkinson Road, has just been awarded by the Government to the Elevators Supply and Equipment Co., whose tender estimated the cost of the installation at \$25,000.

Tenders

Ottawa, Ont.—The time for receiving tenders for completion of the jetty at Steveston, at Mouth of Fraser River, New Westminster, B.C., is extended to Wednesday, July 2, 1913. R. C. Desroches, secretary, Department of Public Works.

St. Rose Village, Que.—Tenders, addressed to J. A. Joly, secretary-treasurer, will be received up to 7th July for the supplying of materials and erection of the following works: Water tank, sewer purification system, filtration plant, pumps and power house for the water work system. Specifications and plans at the office of the secretary-

treasurer, also at the office of the engineers of the village, MM. Ouimet & Lesage, 76 St. Gabriel Street, Montreal.

Winnipeg, Man.—Tenders will be received up to Wednesday, July 2, by the Board of Control, for the delivery and installation of two horizontal, two-stage turbine pumps, direct coupled to a constant speed induction motor, with switching gear and starter panel; each pump to be capable of delivering 3,600 Imperial gallons per minute, against a pressure of 150 lbs. per square inch, or 1,800 Imperial gallons per minute against a pressure of 300 lbs. per square inch. These pumps are to be used in case a fire outbreak during the summer months, and the estimated cost is \$10,500.

Marine

Vancouver, B.C.—The Pacific Great Eastern Railway Co. have started constructing a 2,500 ft. wharf at Newport, at the head of Howe Sound.

Sorel, Que.—The Sorel shipyard is having its activity extended to the building of ships instead of barges and dredges. A Government steamer for use on Lake Winnipeg is now being constructed there and will be shipped in sections and assembled at Selkirk. This is a result of the tenders received being unsatisfactory. It is probable that, hereafter, more of the Government steamers will be built at Sorel, instead of being done by contract.

New Incorporations

The Atlas Power Company, Ltd., has been incorporated with head office at Ashcroft, B.C.

The Dominion Mechanic Works, Ltd., Montreal, has been incorporated with a capital stock of \$20,000 by Zephirin Monte, Ernest Charette, and others, to manufacture machinery.

Miville Mfg. Co., Ltd.—Incorporated at Toronto, capital \$40,000, to manufacture and sell machinery and hardware, at Sturgeon Falls; incorporators: Azarie A. Aubin, Joseph E. Serre, etc., Sturgeon Falls.

Personal

R. H. Hopkins, B.A.Sc., has been temporarily appointed town engineer for Lindsay, Ont.

A. S. Wooten, waterworks superintendent, New Westminster, has resigned, and will take a position as construction engineer.

Thomas J. Drummond, president of the Lake Superior Corporation, who has been seriously ill for some time, is recovering and is expected to return to business on an early date.

Steven J. Kehoe has been appointed superintendent of the Norwich (Conn.) Gas and Electric plant at a salary of \$2,000 a year. He was previously superintendent of the Norwich and Western Traction Co. Mr. Kehoe served his time with the Ottawa Electric Co., and is a son of James Kehoe, of Gloucester, near Ottawa.

Obituary

Francis Hyde, head of the contracting firm of Hyde & Son, Ltd., Montreal, died at his residence, Outremont, Que., on Sunday night.

Joseph Ulric Beaupre, sen., a well known foundryman, died at his residence, 103 Convent Avenue, St. Henry, Que., on Thursday, June 12. He was 71 years of age.

David C. Burpee, a well known contractor and head of the firm of D. C. Burpee & Son, Fredericton, B.C., died last week at his home at Gibson, N.B., at the age of 69 years. In the early seventies he entered into partnership with his brother-in-law, the late H. G. Simmons, and engaged in bridge building.

Trade Gossip

Increased Capital.—The capital stock of the Canada Wood Specialty Co., Ltd., is increased from \$50,000 to \$200,000.

The Precision Tool Works, 126 Adelaide St. E., Toronto, have recently installed a Hendey 20-in. lathe, and a Universal No. 2 milling machine, purchased from A. R. Williams & Co., Toronto. These will be used in their shops for tool, die, jig and gauge work.

The Mechanical Assembling Co., Ltd., 362 Adelaide St. W., Toronto, have opened up a factory where they will assemble on contract all small mechanical devices, such as, adding machines, stamp affixers and novelties of all kinds which require light riveting, soldering or plating. It has been long felt by the organizers of this company that such an enterprise would meet with the approval of manufacturers who have not enough repetition work to keep up a permanent staff of assemblers.

SELECTED MARKET QUOTATIONS

Being a record of prices current on raw and finished material entering into the manufacture of mechanical and general engineering products.

FIG IRON.

	Per Ton.	
Foundry No. 1 and 2, f.o.b., Midland	\$19 00	\$19 50
Gray Forge, Pittsburg	14 65	
Lake Superior, charcoal, Chicago	16 75	
	Mont'l. Tor'to.	
Canadian f'dry, No. 1..	\$21 00	\$20 00
Canadian f'dry, No. 2..	20 50	19 50
Middlesboro, No. 3....	23 50	23 50
Summerlee, No. 2	25 00	26 50
Carron, special	25 00
Carron, soft	25 00
Cleveland, No. 1	24 25	25 00
Clarence, No. 3	23 75	24 50
Jarrow	25 50
Glengarnock	26 00
Radnor, charcoal iron.	30 00	34 50
Ferro Nickel pig iron (Soo)	25 00

BILLETS.

	Per Gross Ton.	
Bessemer billets, Pittsburgh ..	\$26 50	
Open hearth billets, Pittsburgh	26 50	
Forging billets, Pittsburgh	34 00	
Wire rods, Pittsburgh	30 00	

FINISHED IRON AND STEEL.

Per pound to large buyers:

	Cents.
Common bar iron, f.o.b., Toronto..	2.10
Steel bars, f.o.b., Toronto.....	2.20
Common bar iron, f.o.b., Montreal.	2.15
Steel bars, f.o.b., Montreal.....	2.25
Bessemer rails, heavy, at mill....	1.25
Iron bars, Pittsburgh	1.65
Steel bars, Pittsburgh, future	1.40
Tank plates, Pittsburgh, future...	1.45
Beams, Pittsburgh, future	1.45
Angles, Pittsburgh, future	1.45
Steel hoops, Pittaburgh	1.60

Toronto Warehouse f.o.b., Toronto.

	Cents.
Steel bars	2.30
Small shapes	2.45

Warehouse import, freight and duty to pay: Cents

Steel bars	1.95
Structural shapes	2.05
Plates	2.05

Freight, Pittsburgh to Toronto:

18 cents carload; 21 cents less carload.

BOILER PLATES.

	Mont'l. Tor'to.	
Plates, ¼ to ½-in., 100 lbs.	\$2.35	\$2.35
Heads, per 100 lbs.....	2.65	2.95
Tank plates, 3-16 in.	2.60	2.60
Tubes, per 100 ft., 1 inch	9.00	8.50
“ “ 1¼ in.	9.00	8.50
“ “ 1½ “	9.00	9.00
“ “ 1¾ “	9.00	9.00
“ “ 2 “	8.75	8.75
“ “ 2½ “	11.50	11.50
“ “ 3 “	12.00	12.00
“ “ 3¼ “	13.75	13.75
“ “ 3½ “	14.50	14.50
“ “ 4 “	18.00	18.00

BOLTS, NUTS AND SCREWS.

	Per cent.
Stove bolts	80 & 7½
Machine bolts, ¾ and less	65 & 5
Machine bolts, 7-16.....	57½
Blank bolts	57½
Bolt ends	57½
Machine screws, iron, brass	35 p c.
Nuts, square, all sizes.....	4c per lb off
Nuts, Hexagon, all sizes..	4¼ per lb off
Flat and round head.....	35 per cent.
Fillister head	25 per cent.
Iron rivets	60, 10, -0 off
Wood screws, flathead, bright	85, 10 p c off
Wood screws, flathead, brass	75, 10 p c off
Wood screws, flathead bronze	70, 10 p c off

National-Acme "Milled Products."

Sq. & Hex Head Cap Screws	65 & 10%
Sq. & Hex Head Cay Screws	65 & 10%
Rd. & Fil. Head Cap Screws	45-10-10%
Flat & But. Head Cap Screws	40-10-10%
Finished Nuts up to 1 in. . .	75%
Finished Nuts over 1 in. . .	72%
Semi-Fin. Nuts, up to 1 in...	75%
Semi-Fin. Nuts over 1 in....	72%
Studs.....	65%
Discounts f.o.b., Montreal.	

WROUGHT IRON PIPE.

The following are Toronto jobbers' discounts on pipe in effect from April 21, 1913:

	Buttweld		Lapweld	
	Black	Gal.	Black	Gal.
¼ ¾ in.	62	47
½ in.	68	58
¾ to 1½ ...	71½	61½	68½	58½
2 in.	71½	61½	68½	58½
2½ to 4 in. . .	71½	61½	70½	60½
4½ to 6 in.	71½	61½
7, 8, 10 in.	66	54

X Strong P. E.

¼, ⅜, ½ in. . .	56½	46½
¾ to 1½ in. . .	67½	57½
2 to 3 in.	68½	58½
2½ to 4 in.	65	55
4½ to 6 in.	64	56
7 to 8 in.	55	45

XX Strong P. E.

½ to 2 in.	43	33
2½ to 4 in.	43	33

PRICES OF WROUGHT IRON PIPE.

Standard.	Extra Strong.	D. Ex. Strong.
Nom. Price.	Prices	Size Price
Diam. per ft.	Ins. per ft.	Ins. per ft.
1/8 in \$.05½	1/8 in \$.12	1/2 \$.32
1/4 in .06	1/4 in .07½	3/4 .35
3/8 in .06	3/8 in .07½	1 .37
1/2 in .08½	1/2 in .11	1¼ .52½
3/4 in .11½	3/4 in .15	1½ .65
1 in .17½	1 in .22	2 .91
1¼ in .23½	1¼ in .30	2½ 1.37
1½ in .27½	1½ in .36½	3 1.86
2 in .37	2 in .50½	3½ 2.30
2½ in .58½	2½ in .77	4 2.76
3 in .76½	3 in 1.03	4½ 3.26
3½ in .92	3½ in 1.25	5 3.86
4 in 1.09	4 in 1.50	6 5.32
4½ in 1.27	4½ in 1.80	7 6.35
5 in 1.48	5 in 2.08	8 7.25
6 in 1.92	6 in 2.86
7 in 2.38	7 in 3.81
8 in 2.50	8 in 4.34
8 in 2.88	9 in 4.90
9 in 3.45	10 in 5.48
10 in 3.20
10 in 3.50
10 in 4.12

IRON PIPE FITTINGS.

Canadian malleable, 40 per cent.; cast iron, 65; standard bushings, 70; headers, 60; flanged unions, 65; malleable bushings, 65; nipples, 75; malleable, lipped unions, 65.

COKE AND COAL.

Solvay Foundry Coke	5.95
Connellsville Foundry Coke	5.45
Yough, Steam Lump Coal	3.83
Penn. Steam Lump Coal	3.63
Best Slack	2.95
All net ton f.o.b. Toronto.	

OLD MATERIAL.

	Tor'to.	Mont'l.
Copper, light	\$12 05	\$11 00
Copper, crucible	15 00	13 50
Copper, uncre'bled, heavy	13 05	12 50
Copper wire, uncre'bled..	13 05	12 50
No. 1 machine compos'n..	12 00	11 00
No. 1 comp's'n turnings..	10 00	10 00
New brass clippings	9 00	9 00
No. 1 brass turnings	8 30	7 75
Heavy lead	3 40	3 75
Tea lead	3 00	3 00
Scrap zinc	4 00	3 75
Dealers' purchasing prices.		

METALS.

	Mont'l.	Tor'to.
Lake copper	17.00	16.00
Electrolytic copper .. .	17.00	16.00
Spelter	6.00	5.75
Lead	5.25	5.50
Tin	50.00	49.00
Antimony	10.00	9.75
Aluminum .. .	21.00	22.00

SMOOTH STEEL WIRE.

No. 6-9 gauge, \$2.35 base; No. 10 gauge, 6c extra; No. 11 gauge, 12 extra;

No. 12 gauge, 20c extra; No. 13 gauge, 30c extra; No. 14 gauge, 40c extra; No. 15 gauge, 55c extra; No. 16 gauge, 70c extra. Add 60c for coppering and \$2 for tinning.

Extra net per 100 lb.—Spring wire; bright soft drawn, 15c; charcoal (extra quality), \$1.25.

SHEETS.

	Mont'l.	Tor'to.
Sheets, black, No. 28....	\$2 85	\$3 00
Canada plates, ordinary,		
52 sheets	2 80	3 00
Canada plates, all bright.	3 70	4 15
Apollo brand, 10¾ oz.		
(American)	4 30	4 20
Queen's Head, 28 B.W.G..	4 50
Fleur-de-Lis, 28 B.W.G..	4 20
Gorbal's Best Best, No. 28	4 45
Viking Metal, No. 28....	4 40

NAILS AND SPIKES.

Standard steel wire nails,		
base	\$2 40	
Cut nails	\$2 60	2 65
Miscellaneous wire nails..	75 per cent.	
Pressed spikes, 5/8 diam.,		
100 lbs.	2 85

FINE STEEL WIRE.

Discount 25 per cent. List of extras. In 100-lb. lots: No. 17, \$5; No. 18, \$5.50; No. 19, \$6; No. 20, \$6.65; No. 21, \$7; No. 22, \$7.30; No. 23, \$7.65; No. 24, \$8; No. 25, \$9; No. 26, \$9.50; No. 27, \$10; No. 28, \$11; No. 29, \$12; No. 30, \$13; No. 31, \$14; No. 32, \$15; No. 33, \$16; No. 34, \$17. Extras net. Tinned wire, Nos. 17-25, \$2; Nos. 26-31, \$4; Nos. 30-34, \$6. Coppered, 75c; oiling, 10c.

MISCELLANEOUS.

	Cents
Putty, 100 lb drums	\$2.70
Red dry lead, 560 lb. casks, per	
cwt.	6.00
Glue, French medal, per lb	0.10
Tarred slaters' paper, per roll...	0.95
Motor gasoline, single bbls., gal..	0.26
Benzine, per gal.	23½
Pure turpentine	0.60
Linseed oil, raw	0.60
Linseed oil, boiled	0.63
Plaster of Paris, per bbl.	2.10
Plumbers' Oakum, per 100 lbs....	3.25
Pure Manila rope	17

The General Market Conditions and Tendencies

This section sets forth the views and observations of men qualified to judge the outlook and with whom we are in close touch through provincial correspondents.

Montreal, June 16.—The good news that the machine tool market has picked up is now general, and many of the big supply houses are jubilant. A number of the best orders have come from small towns, one of the biggest firms said today, which merely verifies the fact that for the traveller in big machinery lines the lure of the big city is fading. First, the small towns are not worried by daily calls of salesmen, like the cities are, and then the really big factories are now locating in small towns where it is possible for the mechanic to have good schools for his family and a nice house to live in. Besides, he is not only able to make a living, but he is able to make life worth living, and thereby solves the mischievous labor problem which is such a menace to industrial life in the city. From the United States it is reported that much improvement has taken place in rolled steel orders, and these have come from Canada in some cases. In Pittsburg, it is reported that some large orders have been placed for steel pipe, and that the mills are from 14 to 16 weeks behind. Some large orders are reported from the Maritime Provinces, where oil booms have been in vogue. If

the laying of pipe for two or three long distances develops early, there will be some good business in sight at or near Moncton, N.B. As an American syndicate are in control, most likely the piping will be ordered in Pittsburg.

Pig Iron and Copper.

Pig iron has been open for many enquiries during the week. This applies to foundry grades, and to deliveries for the second half of the year. Many of the smaller enquiries, however, include prompt shipment. Much of this business was reported from the railways and some from pipe makers. A large dealer stated that while consumption was active, very few contracts had been placed, which showed signs of waiting on the part of those who think the price may go lower. There is a general alertness and a waiting for a "turn" in the market, which is expected early in July. Copper showed some improvement today, but the market was reported to be speculative owing to the affinity of this metal to operations in securities. A reaction is reported, however, industrially, and this means a recession, based upon the industry on this Continent and in

Europe. There is a reported decrease in melting in Europe, and this has one effect, namely, to show how production has exceeded deliveries. With small buying and liberal output, there is bound to be an accumulation of stocks. In electrolytic copper there was a decline of about an eighth of a cent. Copper sheets were nominal, with steady advance for extras. Tin, after a period of fluctuation, is again up in price. There was an irregular market all week, with a net decline in spot and an advance in futures. The decline was caused by the large deliveries on June contracts by local operators and foreign holders. Antimony, spelter and aluminum are all considered unchanged. As for old metals and old material the market is easy and slow.

Toronto, June 17, 1913.—The condition of both the steel and machinery market was considerably improved this week, and, judging from a report received from one of the largest machinery and supply houses in the country on conditions west of here, the outlook for the remainder of this month and July is anything but discouraging. In fact there is likely to be a change in the next few weeks which should result in much brisker trade. The machine tool business seems to be the most unfortunate at this period. Whereas things are slack in that department, other lines are selling remarkably well. As a rule in time

of depression, the first department to feel a slackening off is that of steam engines, but strange to say the business done in these specialties has been remarkably good right up to the present, and prospects continue exceedingly bright. The tractor business west of here is reported as being dead. The contract was let recently for equipment for the new technical school, the order being divided between two of the largest machine tool houses in the city.

Pig Iron and Steel.

Unlike last week, when business was reported dead in all steel lines, this week there has been a steady demand for tubes, sheets, bars, etc. Manufacturers will do well to watch the market carefully just now, and exercise considerable discretion, as there is likely to be a considerable reduction in prices before long. Conditions in the iron and steel market in the United States have clearly indicated this for several weeks. The mills here and there are catching up with their orders, and inside of six weeks manufacturers may expect to see a considerable

dropping off in price of pig iron and steel in all departments.

Motor car firms are making inquiries, but as a rule they are not in the market for material until toward December. Sometime ago, we had a note in these columns to the effect that Mr. Max Morrell had been placed in charge of the Ontario business of the Dominion Steel and Iron Co., with offices at 18 Wellington St. E. At present only a stock of nails is being carried, 25,000 kegs being stored in a shed at the Merchants Mutual Line at the foot of York St., the same supply being kept in stock at Fort William. In a month's time, the business will be extended, to include steel wire of all kinds. Mr. Morrell reports that business in this line has been remarkably good since he started here.

Metals.

The market is very quiet, copper especially. Manufacturers are just buying as much as they require to go on with, and there is no feature in the market to speak of.

St. John, N.B., June 16.—A saw and grist mill at Temperance Vale, N.B., owned by James Pinder, M.P.P., was destroyed by fire last week. The loss, which included all the contents and machinery in the mills, was partially covered by insurance. A new industry has been established at Albert, N.B., and Archibald Oliver has begun the manufacture of concrete blocks for building purposes, which although only on a moderate scale at present, gives promise of assuming much larger proportions. The plant is soon to be enlarged and gasoline power installed. F. W. Sumner of Moncton, N.B., says that the Maritime Oil Fields Co., are putting in a lot of new machinery and making arrangements

for an extensive development of their properties. He also said that he did not think the project of piping natural gas from Moncton to St. John would be undertaken for some time, as the estimated cost was about a million dollars. The company intends to determine whether or not it will be possible to find a supply of natural gas nearer St. John, so that they are not likely to pipe gas from their present resources until they ascertain the extent of possible oil finds near Sussex. A big lumber strike is on at St. John. About 1,600 men are affected. The saw-mills in which the men are out for higher wages are those of Stetson, Cutler & Co. (two mills), John E. Moore, Miller Bros., Hilyard Bros., J. R. Warner, Randolph & Baker, F. E. Sayre & Co., Murray & Gregory, and Chas. Miller. An increase of twenty-five cents a day has been demanded by the men, and the employers have refused to make the grant, claiming that conditions will not warrant it. Work on the new bridge across the Reversing Falls, to be constructed by the Provincial Government, was held up last week when a strike occurred amongst the men employed by contractor C. A. MacVey. About thirty men went out.

The International Engineering Works, Ltd., Amherst, N.S., have furnished one 12 x 12 inch horizontal side crank engine, 85 b.h.p., 280 r.p.m.; also one 10 x 10-inch horizontal side crank engine, 50 b.h.p., 300 r.p.m., to the Wellesley Hospital, Toronto; one 13 x 14 inch horizontal side crank engine, 120 b.h.p., 275 r.p.m., to the New Method Laundry, Toronto, and one 14 and 25 x 30 inch tandem Corliss engine, 260 b.h.p., 115 r.p.m., to the Meaford Brick Co., Meaford, Ont.

The Precision Tool Works
 Tool makers to Their Majesties the Canadian Manufacturers.
Dies
 Bending, Forming, Drawing, Blanking, and sub-press style in any of the above.
 Tools, Screw Dies, Jigs, Gauges, etc.
 The accuracy of our work guaranteed to be within limits specified on drawings or by order.
 126 Adelaide St. E., Toronto

JAMES R. CAMERON, M. E., Manager PHONE NORTH 5831

THE PATENT SELLING & MFG. AGENCY

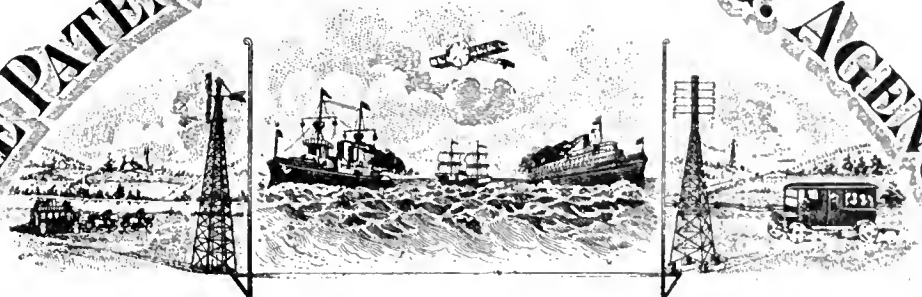

PATENT EXPERTS—MECHANICAL ENGINEERS

Patents Caveats Trade-marks Copyrights Designs Procured	Patents Obtained Sold Developed and Manufactured on Royalty	Inventions Perfected Marketed Protected Handled and Developed	Searches Extensions Licenses Assignments Agreements Renewals	Working Drawings Dies and Tools Patterns Estimates Given on Rights and Manufacturing Costs.
--	---	--	---	--

WRITE FOR PRICES AND TERMS. Address: SUITE 301-302, 22 COLLEGE STREET, TORONTO, ONT.

Simonds Hack Saws

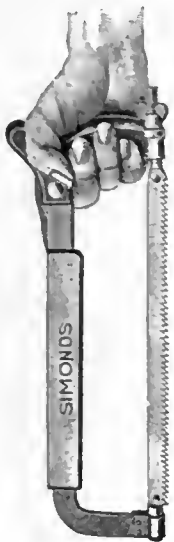

There are people in every community who want things a little better than the average of the other people. To this trait in human nature do we attribute our success with Simonds Hack Saw Blades. We sell blades and frames direct to you.

Simonds Canada Saw Company Limited
MONTREAL, QUE.
 St. John, N.B. Vancouver, B.C.
In the United States, Simonds Mfg. Co.

METAL STAMPINGS

We are manufacturers of stamped parts for other manufacturers. We do any kind of sheet metal stamping that you require. Our improved presses and plating plant enable us to produce the finest quality of work in a surprisingly short time. We can finish steel stampings in Nickel, Brass or Copper. Send us a sample order.

W. H. BANFIELD & SONS
 120 Adelaide St. W., Toronto

ENLARGING SOREL SHIPYARDS.

WORD comes from Ottawa that the Dominion Government is enlarging the usefulness of the much-discussed Federal shipyard at Sorel, Que. Instead of doing small repairs and turning out an occasional vessel for the St. Lawrence and Lower Canada coast work, the Sorel yard is likely before long to be building ships for all Canada. A steamer is under construction in the yards for use on Lake Winnipeg. It will be built in sections, shipped to Port Arthur and thence to Selkirk, and put together there. No satisfactory tenders were received for the construction of the vessel.

BRITISH TRADE.

MR. J. R. BAXTER, who recently returned to Montreal after about a year's sojourn in the Old Country, says "there is no evidence of decadence in British trade and commerce." Naturally his visit was on business, with the result that his firm opened a factory in Birmingham for the production of abrasive wheels.

Mr. Baxter, who laid the foundation of his business in Montreal and Toronto, is a thorough Canadian in spirit, although born in Britain. He chatted freely of his successes, and of the splendid business in Britain everywhere. "There seemed," he said, "as much activity, if not more, there than in Canada." His abrasive had "caught on" well, and they—meaning his company—had no regrets, as the actual and possible business was in every respect satisfying. He intends to take a trip West, and will possibly spend some months in this country.

Mr. Baxter has several sterling agencies which have also done well in Canada, and to his careful handling of so many lines is attributable the large degree of success attained.

ATTENTION! MANUFACTURERS

Here Are Some Snaps

- 1—Laurie Bros. Engine Co. (Montreal), 14" x 27" x 36" cross compound Corliss Engine with fly ball governor high pressure side, including Independent vacuum pump—condensing system.
- 1—Babcock & Wilcox Co.—200 Horsepower single drum water tube boiler, with water column, steam gauge and fitted with all regular fixtures, including settings and brickwork set up complete.
- 1—Babcock & Wilcox Co.—200 Horsepower single drum water tube boiler, with water column, steam gauge, and fitted with all regular fixtures including settings and brickwork set up complete.

Write promptly for further particulars to Box S. 380,

CANADIAN MACHINERY & MANUFACTURING NEWS.
 E. T. Bank Building, Montreal, Que. (25)

CUT GEARS



Spur, Bevel And WormSpiral, Steel, Raw-Hide

ACCURACY AND PROMPT DELIVERY

When you want a gear cut you want it quickly,—we emphasize our promptness without sacrificing accuracy.

A. E. WHITEHOUSE Montreal
76 GEORGE ST.

Ideas at Two Cents Each

- ‡ An idea that's worth anything at all to a Mechanical man is worth more than two cents.
- ‡ It might be worth hundreds of dollars.
- ‡ Every issue of "CANADIAN MACHINERY" is full of practical, helpful ideas. You ought to be able to sift out four each month that would prove of some use to you. Put a value of two cents on each and your subscription has been paid.
- ‡ You cannot afford to miss even one issue—you might miss the idea that would be worth hundreds of dollars.
- ‡ The date on the label of your "CANADIAN MACHINERY" wrapper shows when your subscription expires. One dollar will renew it for a year.

Don't put off Renewing—Do it to-day

Classified Advertisements

Those who wish to sell or buy a business, obtain competent help, connect with satisfactory positions, or secure aid in starting new enterprises should not fail to use the Want Ad. Page of "CANADIAN MACHINERY."

If you want to sell or buy a second-hand lathe, planer or any other shop equipment, let "CANADIAN MACHINERY" pick out a seller or buyer for you. How about that second-hand engine or boiler which you would like to dispose of?

"CANADIAN MACHINERY" is the central market place of the machinery trades throughout Canada.

There is always some one looking for just such proposition as you have to offer.

Rates (payable in advance):—2c per word first insertion, 1c per word subsequent insertion, 5c additional each insertion when Box Number is required. Each figure counts as one word.

FOR SALE

MACHINERY FOR SALE—NEW AND SECOND-HAND machinery, engines, hoilers, wood and iron working machinery and supplies. Write, stating what you require. Prompt and careful attention to all inquiries. The Advance Machine Works Co., Montreal, Que.

FOR SALE—1 KYNOCH GAS ENGINE, 80 h.p., complete, with generator, etc.; 1 Stover gasoline engine, 18 h.p.; 1 30 h.p. boiler with connections. All these machines are in perfect condition, and have not been used long. For full information apply to J. B. & A. Gault, St. Francois, Co. Montmagny, P.Q.

FOR SALE—ALMOST NEW DIFFERENTIAL tackle and truck; carry two tons. Canada Representatives, 193 Spadina Ave., Toronto. (22)

FOR SALE—ALMOST NEW TWO 700-GAL-lon cypress wood tanks with fittings, and 4 one hundred-gallon tanks on castors. Canada Representatives, 193-195 Spadina Ave., Toronto. (22)

GRAY-IRON
Light
MACHINERY CASTINGS
THE GEORGETOWN FOUNDRY CO.
GEORGETOWN, ONTARIO
Let Us Figure On Your Requirements.
Jobbing Work A Specialty.
CASTINGS

Morton Manufacturing Co.
Draw Cut Shapers, Special Draw Cut R. R. Shapers, Special Locomotive Cylinder Planers.
Portable Planers, Stationary & Portable Key Way Cutters, Finished Machine Keys.
Office & Works, Muskogean Heights, U.S.A.

HARKER & KEMBLEY
Machinists And Brass Finishers
Brass and Aluminum Castings
Fire Department Supplies
All Kinds of Special and Experimental Work
81 PETER ST. TORONTO
PHONE ADELAIDE 1031

A want ad. in this paper will bring replies from all parts of Canada.

Personal

L. W. Rundlett, city commissioner of Moose Jaw, Sask., has been appointed city engineer.

John Certes, C.E., of London, Eng., has returned home to prepare a report on the cost of erecting and operating a municipal gas plant at Ottawa.

Norman K. Hay has been appointed city engineer of Sydney, N.S., to succeed Mr. Campbell. Mr. Hay has been construction engineer with the Dominion Iron and Steel Company.

Arthur Fraser, son of J. K. Fraser, superintendent of the Open Hearth Department at the Dominion Steel and Iron Plant, Sydney, N.S., was accidentally shot by his chum last week.

Sir William Mackenzie, president of the C.N.R. in an interview last week said he expected the shipbuilding boom in Great Britain to break, and that his company will not lay down any more keels for his trans-Atlantic line until this takes place.

William Hunt, assistant pumping engineer, at Peterborough city waterworks pumping station, was presented with a handsome chair by the officials and engineers of the works, on Thursday, June 5th, on the occasion of his marriage.

C. L. Spafford, on the occasion of his leaving the employ of the Jenekes Machine Co., Sherbrooke, Que., was presented with a gold watch by the foremen of the shop, the engineering and office staffs. The presentation was made by Mr. Mills.

George White, of the firm of George White & Sons, London, Ont., manufacturers of threshing machines, engines and boilers, succumbed rather unexpectedly on Saturday evening, June 7, death being due to an acute attack of pneumonia. Mr. White, who was 79 years of age, was one of London's oldest manufacturers.

The
CONTINENTAL HOTEL
Chestnut Street, Corner of Ninth
PHILADELPHIA
Remodeled, Refurnished,
400 Rooms. 200 With Bath.
Rates: \$1.50 to \$5.00
European Plan
The Best Cafe in the City
Frank Kimble,
Manager

Patent Attorneys

Even Though you Don't Know It.
Fortunes of your future may arise from patented improvements. If you haven't the time to develop inventions, why not profit from the brain of your neighbors. Ask
H. D. MacDONALD
818 Press Bldg., DETROIT, Mich.

TRADE MARKS, COPYRIGHTS & DESIGNS
PATENTS
LLOYD BLACKMORE & COMPANY
LUMSDEN BUILDING, TORONTO.
ALSO, HOPE BLDG. OTTAWA, & WASHINGTON, D.C.
We have an interesting and valuable booklet "PATENT PROTECTION" which will be sent free upon request.

PATENTS PROMPTLY SECURED
in all countries. Ask for our Inventor's Adviser, which will be sent free.
MARION & MARION, 364 University St.
Merchants Bank Building, corner St. Catherine St., MONTREAL. Phone Up 6474 and Washington, D.C., U.S.A.

PATENTS
PIGEON, PIGEON & DAVIS
71A, ST. JAMES STREET, MONTREAL
Phone, Main 3025
16 years' experience in Canada, U.S. and Europe

Pattern Makers
PATTERNS
WOOD AND METAL
Allow us to estimate. Satisfactory work guaranteed.
TAYLOR PATTERN WORKS WALKERVILLE, ONT.

PATTERNS of EVERY DESCRIPTION
SATISFACTION GUARANTEED
POTTS PERFECT PATTERNS
PHONE ADELAIDE 103
R. POTTS
87 RICHMOND ST. W., TORONTO

EXPERIMENTAL WORK
Metal Patterns | Dies And Tools
The Martin-Embree Co.
General Machinists
39 WENTWORTH ST. NORTH, HAMILTON, ONT.

99% OF ALL METAL BREAKS CURED BY OUR OXY-ACETYLENE
WELDING
EXPERTS
RUSH WORK OUR SPECIALTY PHONE DAY-ADLAIDE 100
THE FRANCO-CANADIAN WELDING CO., 331 Yonge St. TORONTO



HINTS TO BUYERS

GEARS



HAMILTON GEAR & MACHINE CO.

Cor. Concord
& Van Horne

TORONTO

Specialization — a shop full of modern machinery and skilled mechanics with one object—Cut Gears.



ONE TAKES THE PLACE OF FOUR

One of our Riveting Machines is doing the work of four hand operators, and doing it BETTER. The work is uniform; just as good at 6 P.M. as at 8 or 9 A.M.

Figure up the profit at the end of the year! Can't you save as much? Send us samples of your work, and let us help you.

**The F. B. SHUSTER. NEW HAVEN
CONN.**
Formerly John Adt & Son. Established 1866.
Elastic Rotary Blow Riveter Automatic Wire Straighteners and Cutters, Helix Collars, Foot Pressers, Sprue Cutters, etc

Lanco Balata Belting

probably stretches less than any other belt and is exceptionally strong. Woven by special process, and every thread impregnated with PURE balata gum.

UNEQUALED TENSILE STRENGTH FOR ALL CONDITIONS EXCEPT HEAT.

Write for CATALOGUE.

Federal Engineering Company, Limited
Toronto Montreal



GENUINE ARMSTRONG STOCKS AND DIES

For Threading Pipe or Rod

HINGED PIPE VISES, PIPE CUTTERS, PIPE MACHINES
Both Hand or Power

Manufactured by
THE ARMSTRONG MANUFACTURING CO.
328 Knowlton St.
BRIDGEPORT, CONN.

NEW YORK CHICAGO

MAIN BELTING CO. OF CANADA, LIMITED



LEVIATHAN BELTING

MAIN DRIVES A SPECIALTY

MONTREAL 28 ST. PETER STREET Phone Main 7853
TORONTO 28 WELLINGTON STREET W Phone Adelaide 1887

VIKING

WATERPROOF CEMENT LEATHER BELTS

Will Save You Much Money, Time, Trouble and Worry
"Viking" Belts are just in their element when in wet places and under adverse conditions.
A trial will convince you that they are all-round savers.
Write for particulars.

J. C. McLaren Belting Co., Limited
MONTREAL TORONTO WINNIPEG

The advertiser would like to know where you saw his advertisement—tell him.

Accurate Foundry Cost Control by Economic Methods*

By E. W. Riker

The advantages accruing from the installation and operation of a properly designed cost system in each individual foundry, and which takes account of the conditions peculiar to location, production facilities, etc., are shown by the writer of this paper to be so apparent that no foundry owner, however sceptical, can afford to ignore them.

SO much has been written relating to the subject of this paper by various individuals in their professional capacities and otherwise, and who are regarded authorities on foundry affairs, that it is somewhat difficult to present anything very strikingly new upon the subject or even bring to the reader's attention anything relating to foundry practice that has not been considered many times over, not only from the point of view of "accurate cost control for the foundry by economic methods," but from every other viewpoint that would help improve the efficiency of the foundry; nevertheless, the industrial world and the workers therein are steadily going forward with an increase in proficiency that is almost startling in some directions—the consequence of new ideas—and even though we have all thought over foundry problems many times and have not yet solved all of them, we must not conclude that this is impossible, or that we are informed of all the ideas on the subject that are worth considering.

Foundrymen Sceptical.

Foundrymen, as a group of industrial owners, are, perhaps, the most sceptical class of manufacturers regarding the installation of a cost system—and they hesitate the longest. This is not surprising, when one considers the aversion which foundrymen generally have to the installation of any system of operation that involves detail, or an interruption to the settled state of affairs, with a fear of added cost of execution of the system in way of clerical help. This, however, need not be the case if the system—whether it be a cost system or some other method of operation, is designed to fit the foundry in which it is installed and is, therefore, appropriate and practical.

One of the discouragements to foundrymen is the failure to obtain results from cost systems they have considered and perhaps tried, due chiefly to incompetent professional advice. This is one of the reasons for their scepticism. There are comparatively few foundry specialists in the field to-day who have had sufficient experience in foundry cost work and practice to qualify them as advisers, and who are capable of devising

and installing a foundry cost system and other foundry methods that do not involve extravagant expenditures to maintain. Notwithstanding this, the foundryman needs a cost system, and needs it more to-day than ever before; it being positively necessary to foundry efficiency, economy and progress. The system need not be complicated or top-heavy, embodying a mass of detail with a large clerical force to operate, but it can be a simple, plain and clear statement of current cost conditions; accurate and practical and so valuable that a foundryman or manufacturer who once gets such a system never regrets it nor begrudges the money he spent for its installation.

The Science of Management.

We hear a great deal nowadays of scientific management, and how efficiency can best be secured by purely scientific methods; but these methods are apt to be ultra-refined and are rather expensive affairs to execute, especially when applied to foundry practice, and are not always advisable by any means. Rather let us consider the science of management as distinguished from scientific management which appeals strongly to a number of practical foundrymen and manufacturers, and is a discrimination that permits a sane, sensible and orderly arrangement of affairs for the economical transaction of business, whether applied to a foundry, a factory or other commercial enterprise.

Science is systematized knowledge, and in these days of business activity, with competition growing keener day by day, it is necessary for executives to have all the knowledge practically and economically obtainable, relating to current operations of their businesses. The best way to secure this knowledge is through the operation of a dependable cost system that gives the executive control of his business. The cost system is called the mainspring of the business, but it must be right and it must be practical; and when installed, it ought to be clearly understood that the system is not automatic and that its value depends largely upon the understanding which the chief executive of the business has of its principles and its possibilities.

No business is made a success by the cost system alone, though business success is rarely secured to its full extent

without the aid of a cost system. It is the chief instrument used to attain a high degree of efficiency through intelligent, energetic and enthusiastic management, made practical by good organization, permanent policies and business integrity.

Foundry Cost Control Possible.

Accurate cost control of a foundry by economical methods is possible beyond the question of a doubt. A foundry cost system can be devised to fit the foundry for which it is designed, which will absorb and account for every disbursement for material and labor, whether this is a direct or productive item, or an indirect or non-productive charge. Furthermore, these disbursements may be separated or classified to divisions or departments for efficiency in foundry management, and also separated and charged to classes of castings or to individual orders to show complete cost of product by classes or by specific orders. All of this can be tabulated and presented weekly instead of monthly, as is done in some foundries, and in a manner that is accurate, therefore, dependable; simple, therefore, intelligible; practical, therefore, worth while; and economical, because it can be operated without excessive cost.

The usual divisions of an iron foundry recognized as productive departments, are: (A)—cupola; (B)—core room; (C)—moulding; (D)—cleaning and chipping.

The non-productive or indirect expenses, known as foundry expenses, overhead charges, or burden, include superintendent, foundry clerks, shipping yardmen, general laborers, crane-men, machinists, carpenters, blacksmiths, freight and cartage, pattern repairs and renewals, tool repairs and renewals, bad castings, defective castings.

These expenses are taken care of through the medium of standing order numbers to which they are charged and tabulated for distribution to the productive departments and classes of castings as part of the costs, and further to inform the superintendent or foreman in charge, currently of variations in this class of disbursement for prompt action when any specific item or items show unusual increases.

The power, heat, light, water and protection expenses are treated in a manner

*From a paper read recently before the Philadelphia Foundrymen's Association.

similar to the other foundry expense disbursements and distributed proportionately to the productive departments and classes.

The fixed charges, such as fire insurance, indemnity insurance, depreciation and interest, are absorbed into cost of product, but shown on the weekly report separately, for the reason that these items, being "fixed," cannot be increased or decreased by act of the foundry superintendent or foreman, and, therefore, should not be included with other items of foundry expenses which can be increased or decreased by the superintendent or foreman, according to the degree of efficiency he shows in the management of the foundry affairs.

Foundry betterments, or permanent investments, such as real estate, buildings, machine tools, general tools, patterns, power transmission, piping, electrical equipment, etc. are handled by the usual accounting methods applied to this class of property accounts, but the charges thereto are not absorbed in current cost of product—only their upkeep and depreciation.

Cupola Report.

Starting with the raw material, a cupola report is prepared showing grades of pig iron melted, with quantity and value of each, and also quantity and value of machinery and foundry scrap to show total melt. From this is deducted the returns and bad wastings which gives the net cost of metal melted. To this is added the cost of fuel and supplies, such as coke, fire sand, fire clay, brick, limestones, etc., together with the labor engaged upon the cupola work and the power consumed to give net cost of melt, which is reduced to a rate per pound of metal melted. From this melt, and upon the cupola report, the pounds of castings produced are shown, separated to good and bad castings.

The cupola report also shows:

- (1)—Per cent. of good castings to gross melt.
- (2)—Per cent. bad to total castings.
- (3)—Per cent. of returns to gross melt.
- (4) The melting loss.
- (5)—The ratio of this loss to melt.

The report is complete, and includes every item of cost of cupola operation reduced to a net cost per pound of metal melted from the cupola spout to the ladle ready to pour, for subsequent use in ascertaining cost of castings per pound by classes and in total, or cost of castings by jobs or pieces. The report is also decidedly helpful to the foundry superintendent or foreman in charge for measuring the efficiency of this important foundry department.

Other Departmental Reports.

Similar reports are prepared for the coreroom, the moulding and the cleaning and chipping departments to show cost of operation of these divisions, both for department efficiency and to include in final summary of cost of castings.

The overhead expenses are tabulated in one report to show the disbursements in detail covering this class of cost. This report also shows cost of power, heat, light, etc., and the amounts that are apportioned weekly to cover the fixed charges. Thus, all money expended for material, labor and foundry supplies, whether for direct or indirect use, is properly accounted for.

Finally, all these reports are summarized on a cost-of-casting-sheet, to show total cost of operation by departments, and total cost of castings by classes with notations of period or average costs to date for departments and classes. These several reports from the weekly cost statement with every item of cost absorbed and capable of proof with the books of account.

Comparative Statements.

Additional reports in the nature of statistics may be prepared from the weekly cost reports, arranged to show results comparatively by weeks as a further guide to the superintendent in his effort to promote efficiency. A statement of comparative results arranges facts developed in the cupola department relating to good castings, had castings, returns, total from melt, melting loss, total melt, average melt per day, defective castings, cost of metal, ratio of foundry expense to productive labor, average castings per day, good and bad, and per moulder, and other useful data to indicate how these regular features of the foundry are running along and what variations develop. An analysis of the product and of foundry expenses may also be arranged comparatively to inform the superintendent of variations in these items. These statistical statements are not actually a part of the weekly cost report, but are found very helpful to the foundry management in watching the trend of affairs.

Stock Control System.

In connection with the cost system and auxiliary to it, is a system of stock control which can be operated in a very simple manner to properly regulate purchases of material and foundry supplies and to properly govern their use. A stores and stock system not only provides a current inventory but effectually prevents careless and indifferent buying, overstocking and waste, and furnishes a means of inspection of this class of property that is both desirable

and helpful in the effort to economize in foundry material and supplies.

Weekly Report Scheme.

One of the strongest and most effective features of the foundry cost system, outlined in this paper, is the weekly report scheme, for the reason that reports compiled so frequently give the superintendent or foreman in charge, the opportunity to observe irregular developments in cost of operation and to take prompt action to correct the matter. For this reason alone, the weekly reports are much more valuable to the foundry management, than are those which are prepared only once a month.

In preparing the weekly report, the foundry cost clerk is assisted by suitable forms for recording and reporting data from the several departments which he needs for his report, and as these data come to him daily on analysis sheets prepared for the purpose, it thus assembles the figures needed for his weekly report each day, and further enables him to compile his report at the end of the week promptly and without serious effort.

Cost System Not Theoretical.

There is no theory about the cost system referred to herein, for its practical application has been demonstrated in various large foundries and its effectiveness proven. Its execution does not involve an undue amount of clerical or other expense; on the contrary, the system can be operated so economically that a foundryman who wants to know his costs, and surely all of us do, can hardly afford to neglect the installation of the system.

Two points in connection with the installation of a new cost system, whether a foundry or factory, must be considered and clearly understood; viz., it takes time and perseverance. Various elements must be reckoned with, and various obstacles must be overcome; but, above all, to make the cost system a complete success, it must have the substantial support of the chief executive of the business against all obstacles and objections, physical and human.

A great deal depends upon the cost system; its elements must be thoroughly understood and it must absorb all items of cost—direct and indirect. It is hazardous to the business to use cost figures that do not represent the total expenditures for labor, material and expense and which cannot be proved. If figures are used that do not include or absorb these three chief elements of cost, selling prices are apt to be made that will not show a profit when the fiscal year's balance sheet is prepared.

It is not a difficult matter to ascertain accurately the amounts expended for dir-

ect labor and material; indeed, this is quite simple, but just how to ascertain the overhead, and apportion it equitably and correctly to be sure that all overhead expense is absorbed, requires careful study and a knowledge of the subject obtained from years of actual practical experience. It is safe to assert that a large majority of industrial owners and managers do not fully comprehend what a complete and exact cost system really means, and that such a system is just as necessary to permanent and increasing business prosperity as is good organization, efficient management, adequate equipment and capable workmen.

Elements of a Cost System.

As previously stated, the elements of a cost system must be thoroughly understood and correctly applied. These elements are:—

- 1.—**Material**, that which becomes part of the finished product.
- 2.—**Productive labor** which can be determined by a specific amount or rate, and can be directly charged into cost of product.
- 3.—**Factory expense**, which includes that large number of charges which are necessary to maintain productive labor in the operation of manufacture, and also all items of indirect labor and all repairs, power, heat, light, water, etc.
- 4.—**Administrative expense**, embracing salaries of executives, office clerks, office expenses, etc.
- 5.—**Fixed charges**, consisting of taxes, fire insurance, depreciation and interest; though the latter is not always regarded as a fixed charge and often is omitted as such.
- 6.—**Selling expense**, representing all disbursements for disposing of the product, including branches, agencies, salesmen, etc.

These six elements of cost cover all money expended except for betterments which add to the investment value, such as new buildings, new machinery, tools and other equipment. Costs properly compiled must be classified and tabulated in accordance with the above elements.

Real Function of a Cost System.

In conclusion, let us remember that the real function of a cost system is not merely to record the cost of operation, but to submit data that can be used intelligently to reduce costs. It then performs its duty, and becomes the most valuable agent known to promote foundry and factory efficiency. The logical conclusion, the common sense of the condition, is that every foundry and every industrial plant needs a reliable cost system to present in an orderly manner, regularly, the facts relating to the business, week by week.

FLOATING CRANES FOR PANAMA CANAL.

THE Secretary of War has authorized award of contract for two floating cranes of the revolving type of 250 gross tons capacity each, to the Deutsche Maschinenfabrik A. G., of Duisburg, Germany. There were four bidders—one American, one English, one Dutch, and one German, but the proposal of the German firm was so much lower in price than any other, and the experience, facilities, and reputation of this firm were so excellent, that it was unquestionably the best of those received. The time of delivery for the two cranes is 580 days. They will, of course, be constructed in Germany, and a force is now being organized to take charge of the inspection at the works of the contractor.

The pontoons will be designed and built at the German shipyard, simultaneously with the design and fabrication of the superstructure and operating machinery at the contractor's works in Duisburg. The pontoons, after being fitted with a part of the machinery located below deck, will be towed to the Isthmus, and at the same time the superstructure will be shipped to the Isthmus in a knocked-down condition, final erection of the superstructure and placement of machinery parts being made after arrival on the Isthmus. The cranes are so high, and the weights of the superstructure are so great, that the erection of the jib or arm which carries the loads will probably be effected by means of one of the canal lock chambers, the water level in the lock being lowered sufficiently to permit the jib, which will be assembled on the lock wall, to be fitted to the remainder of the superstructure. A reference to the sketch accompanying this description will give an idea of the work involved.

After final erection and adjustment, each crane will be subjected to a comprehensive series of tests, during which it will be required to demonstrate its ability to handle all the specified loads at the specified reaches, and to perform all of the required motions. The test loads will be 20 per cent. in excess of the rated loads for the "main hoist," and 33 1-3 per cent. in excess of the rated capacity of the "auxiliary hoist." This means that the maximum weight which must be handled without overstrain is 300 gross tons, or 672,000 pounds.

Crane Features.

The cranes for which contract has been awarded will each consist essentially of a steel pontoon 150 feet long, 88 feet wide, and of a depth of 15 feet 9 inches at the sides, and 16 feet 8 inches at the centre. The pontoons will be strongly framed with beams and girders,

and will be sub-divided into watertight compartments of such dimensions that any two exterior compartments can be flooded and the crane remain stable with full load at full reach in any position, and with wind blowing at the rate of ten pounds per square foot from the most unfavorable direction. The pontoons will contain a power generating installation, consisting of a Scotch marine steam boiler, supplying steam to marine type engines driving the main and auxiliary electrical and generating units. These units will furnish direct current at 220 volts to motors located on the superstructure, which latter will drive the wire ropes actuating the blocks to which the loads to be handled will be attached. The cranes will not be self-propelling, but the pontoons are fitted with towing bits, etc., so that they can be handled by tugs. Each pontoon is fitted with four steam capstans, one near each corner, whereby the cranes can be manoeuvred to any desired position. To safeguard the cranes in possible heavy weather, or other circumstances, each is provided with two 3,000-pound anchors and the necessary chain cable, two steam anchor winches being provided for each crane to handle the anchors.

The pontoon supports the fixed and revolving superstructure at a point 39 feet distant from one end midway of the width of the pontoon. Reference to the accompanying sketch will give an idea of this superstructure. In general, it consists of three parts:—First, the fixed superstructure or mast, consisting of a four-sided truncated pyramid firmly secured to the pontoon framing; second, the revolving "bell" which is a four-sided, steel framed structure supported by a combination collar and roller bearing on top of the mast; and third, the arm or jib which is supported on the bell by two hinge pins, and is capable of motion about these pins, the motion being imparted to it by means of two links connecting it to two cross-heads situated at the rear of the bell, and actuated by two vertical screw spindles driven from the machinery house. The bell supports the machinery house, which is situated, as shown in the sketch, at the rear of the former, and a short distance above its bottom. This machinery house contains fixed counterweights, as well as the motors, gears, drums, etc., for operating the main and auxiliary hoists. The bell also supports the driver's cab at a point just below the hinge pins of the jib, from which the operator commands an unobstructed view of the entire field of work.

The bell terminates at its bottom on a circular steel girder carrying rollers, which press against a roller path secured to the mast. The motors for re-

volving the bell and jib around the mast are fixed at the bottom of the mast, and drive gears engaging a circular rack on the annular girder forming the base of the bell. All motions are in the complete control of one man whose station is in the driver's cab. In addition to the driver, there will be required

From the foregoing description of the superstructure, it will be seen that the entire revolving weight rests on the top of the mast and that the jib is prevented from overturning by the resistance of the collar bearing at the top of the mast, and the rollers at the bottom of the bell. The clearances are such that

Hoist Features.

The jib is provided with two hoists designated the "main hoist" and "auxiliary hoist," respectively. The main hoist is fixed at the point of the jib and will consist of two equal blocks, each of a rated capacity of 125 gross tons. These two blocks can be linked together by means of an "equalizer bar," whereby they may be made to form substantially one hoist of 250 tons capacity. Each block of the main hoist will be suspended in ten parts of two-inch wire rope.

The auxiliary hoist will have a rated capacity of 15 gross tons, and will consist of a two-part block swung from a traveling trolley on a runway secured to the lower side of the jib in such a manner that the auxiliary hoist can be operated at any point of this runway at any position of the jib.

The main hoist can handle its rated loads at any point in a full circumference of 360 degrees with the mast as a centre. It can revolve completely under maximum loads, and can, in addition, be luffed in or out by means of the already mentioned links and screw spindles. The main hoist will have the following capacities at the reaches stated; by "reach" is meant the horizontal distance from face of pontoon fender to centre of block:

	100 Tons. Ft.	150 Tons. Ft.	250 Tons. Ft.
Loaded reach over end.	80.1	59.0	21.0
Loaded reach over side.	81.6	62.4	22.3

From any of these reaches the main load can be luffed in sufficiently far to enable the crane to deposit the load on its own deck.

The time of hoisting main loads is as follows:

Tons.	Per Minute.
250	3 ft. 6 in.
125	7 ft.
62.5	14 ft.

The unloaded blocks are raised or lowered at not less than 20 feet per

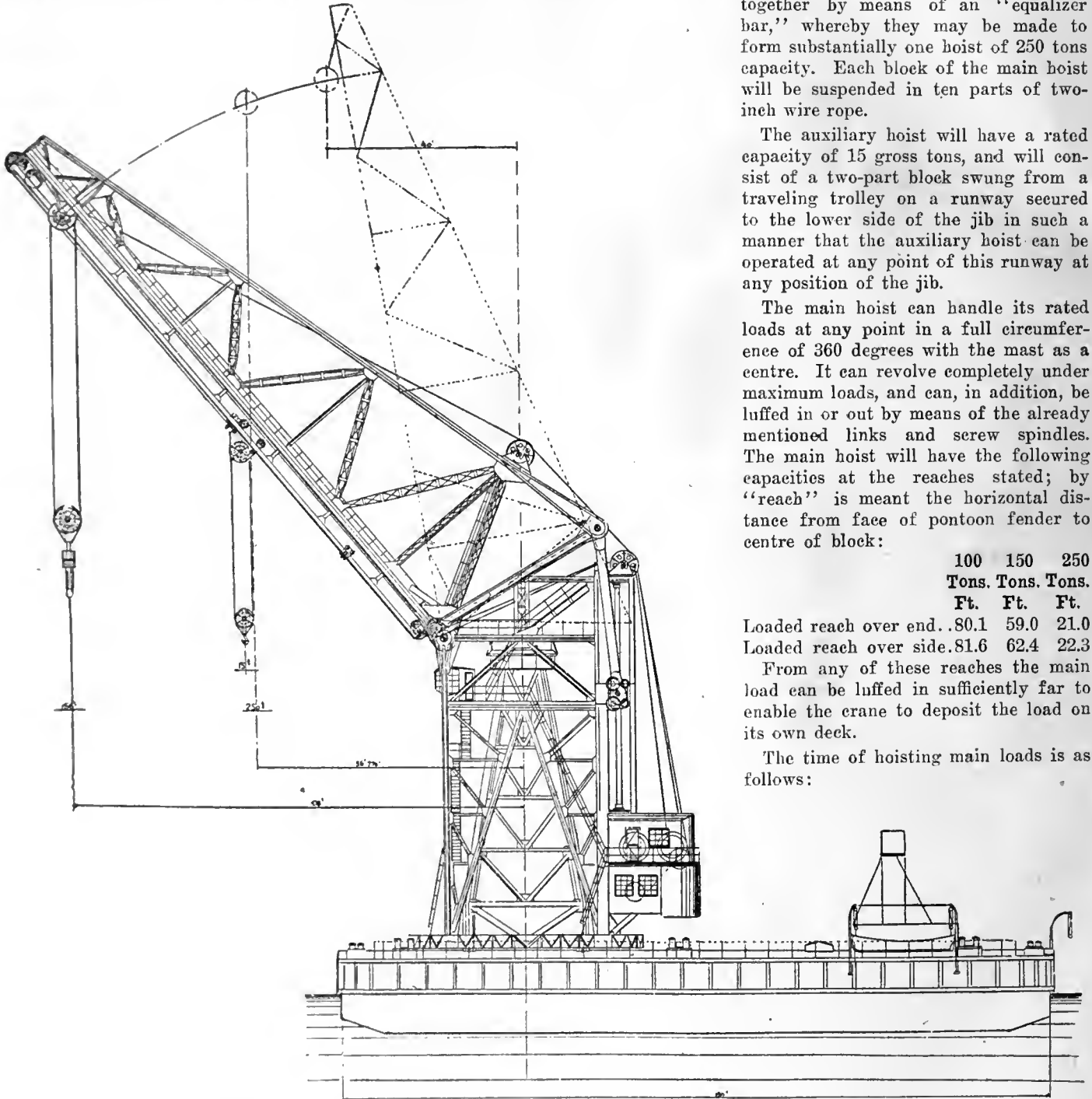

250 TON CAPACITY REVOLVING TYPE FLOATING CRANE FOR PANAMA CANAL.

a machinist in the machinery house on the bell, another machinist in the generating plant in the pontoon, and a fireman for the boiler: thus, with the exception of the deck force for handling lines, etc., but four men are necessary for the operation of each crane.

no part of the revolving superstructure, except the jib, overhangs the pontoon in any position, thus rendering it possible to operate the crane in restricted spaces. The heights of the superstructure are such that unimpeded passage around it is provided in all positions.

minute, and the crane can make one complete revolution in from 5 to 8 minutes, depending on the load and wind, the lower figure being for the most favorable condition without wind. The jib, loaded with 100 tons, can be luffed in from its maximum to minimum reach, in not more than 17 minutes, and luffed out in not more than 13 minutes. With-out load, the jib can be fully luffed in from maximum to minimum reach in not more than 10 minutes, and luffed out in not more than 8 minutes. The speed of hoisting the fully loaded auxiliary block will be not less than 40 feet per minute,

and the unloaded auxiliary block can be raised or lowered at no less than 80 feet per minute. The speed of trolleying the auxiliary hoist along its runway will be from 40 to 80 feet per minute, depending upon the degrees of inclination of the jib.

Pontoon Features.

Each crane will be safely stable in a wind exerting a pressure of 40 pounds per square foot, even with full 300-ton deck load on the pontoon. The pontoon will have a freeboard of not less than 3½ feet when handling maximum capae-

ity loads in any position without deck load; if the deck load be present this free load will be reduced to not less than 2 feet. The maximum longitudinal inclination of the pontoon will not exceed 2½ degrees, and the maximum transverse inclination will not be greater than 5 degrees.

Each crane will be provided with ladders, stairs, gangways, etc., for convenient communication, inspection and repair, and will be fully equipped with all necessary signals and means of communication. Electric light will be installed throughout.

Elevator Accidents, Their Origination and Prevention *

By Reginald Pelham Bolton

It is a noteworthy fact that elevator legislation is more or less of a haphazard kind, and that liberties are taken with this public utility and conveyance in service that are not permitted in other transportation departments or spheres. A pleasing feature of the subject, however, is, as the writer points out, the fact that elevator manufacturers, through their product, contribute little to the accident record.

THE increase of fatalities and injuries resulting from the extensive use of passenger elevators has become sufficiently marked to deserve the careful attention of those who are concerned with the benefit of their fellow-creatures. Complete statistics as to the number of accidental occurrences in and about elevators of all classes throughout the country are not available, but an estimate based upon such official returns as relate to labor alone, indicates that the annual total is now probably in excess of 7,000, of which probably three-fourths are of a preventable character.

Nature of Accidents.

The fact that accidental occurrences in or about elevators are thus found to be deplorably numerous and increasing is not to be taken as a reflection upon the general security of elevator travel, for their number is relatively small in comparison with the vast number of persons utilizing these appliances. Further, by far the larger number of mishaps are not due to failure or fault of the elevator itself, but occur in and about the entrance of, or in the hoistways of such apparatus, from persons falling through unguarded openings into elevator shafts; and, of course, a number are due to the recklessness and incompetence of employees and operators. It remains the fact, however, that a large part of these occurrences are unnecessary.

In no class of transportation are the effects of haste and crowding more apparent and dangerous than in the modern means of vertical transportation, use

of which is now made by all classes of people. It may be conservatively estimated that the economic value of the mere services of persons killed in and about elevators, based upon life expectancy and the loss of time of those injured, would annually exceed the cost of equipment of all passenger and freight elevators with modernized safety appliances.

In a Class By Themselves.

The elevator is a transportation apparatus which is for the most part privately operated and owned. Unlike the railroad, it is not regarded by the law as the apparatus of a common carrier. Unlike the road carriage or car, it is not operated upon the public highways. Unlike the machinery of a factory, it is not utilized exclusively by employees. Its development and use have been, perhaps, too restricted to require the attentions of such legislation as has been rather freely applied to other classes of appliances engaged in transporting human beings. It has, therefore, come about that the legal status of the elevator is in a very indefinite condition; its public regulation is generally local, and, therefore, at best erratic, and the liability for the security of its occupants is as varied as legal practice and rulings.

The attention of the American Museum of Safety has been directed, for some years, towards the accomplishment of some amelioration of existing conditions, and that humane organization made a strong effort to arouse public interest in these measures, and to secure their enactment, but without success. The subject has also received some sporadic attention from the National

Civic Federation, the American Association for Labor Legislation and the New York Association for Labor Legislation, but without effective results.

No Legal Obligation.

With the foregoing exceptions, the obligations of an owner of a building, as regards the security of an elevating appliance, are practically limited to a compliance with the existing local regulations to the purchase of a device commensurate with the existing state of the art, of a design made by a reputable concern, and to the employment of reasonable care in upkeep and operation.

No legal obligation appears to lie upon an owner to alter or modify the appliance in conformity with greater knowledge of the art, or to add to it greater means of security. Until some unfortunate occurrence has taken place, an owner of property naturally feels unwilling to embark on such expenditures. The present system of liability insurance rather tends to such a situation, as an owner has no inducement in the form of reduced premiums, to expend money upon desirable safeguards. If the liability corporation should concede a substantial reduction of premium, in connection with appliances dealing with a certain proportion of the risks attending elevator operation, much could be accomplished without the aid of special legislation.

Legislative Protection Required.

While the law-making powers do not hesitate to direct such measures to be taken with and upon the property of common carriers, they seem to regard the operation of a practically public con-

*From an address before the National Conservation Congress.

veyance within private property as a privileged possession and hesitate to enter the castle of the owner and involve him in enforced expenditures upon a privately operated appliance. Yet an elevator, whether used for the purpose of the carriage of goods, of tenants, or employees, or of visitors to a building, is a common carrier earning a profit, even if indirectly, for it is as much a source of revenue as is the machinery of a factory around which many enforced safeguards have, by legislation, been thrown.

If, therefore, the owner of a building installs elevators for the convenient carriage of tenants and visitors within his property, he does so because the apparatus enhances the value of that property, and that enhancement is largely due to the public use of the appliance, in which use the unknowing users have some right to legislative protection from results of ignorance or incompetence, of neglect or parsimony.

Elevators in New York.

It has taken a long time for this view of the matter to become recognized, even in the city of New York, in which the use of elevators has multiplied beyond all conception of what seemed probable twenty-five years ago. The number of passenger elevators in the Borough of Manhattan alone now exceeds nine thousand, and these increase annually by about five hundred new machines. The estimated number of freight elevators, none of which under present circumstances is subject to official inspection, is not less than ten thousand.

The regulations regarding elevators in Manhattan, while in themselves excellent, are directly applicable to passenger elevators only, with such freight elevators as are within the same shaft enclosure as a passenger elevator. They require the operator to be of reliable and industrious habits, not less than eighteen years of age, with at least one month's experience in his duties. A number of known elements of unsafe character are prohibited and some constructive features of value are insisted upon. No provision is, however, made for automatic interlocking of gates and ear movement, nor are projections in the shaft prohibited.

Manufacturers Complimented.

It speaks volumes for the sense of responsibility of our leading manufacturers of elevators that among all the tens of thousands of machines turned out by such concerns, accidents due to the physical breakage of the machinery of elevators should be in number only what they are, when they include the failure of machines built in days when

the industry was small and the art far less understood than it is at present.

When we reflect upon the fact that the passengers carried in elevators in the city of New York far exceeds in number those carried on all the surface and subway lines, we may the more appreciate the point to which I desire specially to direct your attention, namely, the desirability in the public interest of State regulation, and as far as possible, uniform regulation of the security and operation of elevators. The local regulations may be left to care for details of installation, but the State authority is necessary to require elevators to be not only modern, but progressively modernized appliances; that no antiquated and essentially dangerous apparatus shall be continued in use, and that necessary safeguards and properly qualified operators shall accompany their operation.

Elevators in Tall Buildings

The State may further require that in excessively tall buildings, where the elevators constitute the only practical means of egress in emergency, there shall be a proper sufficiency of such appliances capable of removing the occupants within a reasonably safe period of time. Many loft buildings of twelve storeys and some even exceeding twenty storeys are in existence, in which the elevator accommodation is utterly inadequate for the removal of occupants of upper floors in a reasonable time, in case of emergency. The effectiveness of exterior "fire escapes" and of crooked interior stairways, especially for great heights, is now known to be strictly within certain limitations, and elevators have on many occasions demonstrated their value in the saving of life in panic and fire. Office buildings are constructed thirty and more storeys in height, without fire escapes and with winding stairways which are useless in emergency, and with such limited elevator capacity as would not remove the tenants in less than thirty minutes.

Gate and Doorway Safeguards.

A most important and desirable subject for general action is afforded by provisions for safeguarding elevator gates and doorways. In and about these orifices, as previously observed, a large proportion of unnecessary accidents and fatalities occur. The unlatched door, the open gate, the absence of inner gates, the projecting sill, and the slippery tread, are fruitful causes of deplorable injuries, and have caused the unnecessary loss of many precious lives. The proportion which this class of occurrences bears to the total is evidently large. An analysis of a list of four thousand accidental occurrences shows the following proportions:

Getting on or off ears	58%
Falling through unguarded openings	20%
Fractures and fall of ears, only . .	17%
Mechanics making repairs in shafts, etc.	4%
Unexplained	1%

A number of devices have been developed during recent years, which have overcome objections to their use in the past, whereby the gates of elevators must be securely locked and fastened before the ear can be moved. It would seem that so simple a safety feature would long ago have been demanded by every form of authority.

There has been particular objection in some large cities to the application of devices for locking the gates, on the ground that the speed of operation on rapid schedule service would be retarded and inconvenience and overcrowding would result. In order to satisfy myself upon this point I made, this year, a series of comparative trials of elevators equipped with one such appliance, the Clarke interlocking device, and found that no loss of time in service actually resulted. On the contrary, a trial of the elevators in the Atlantic Mutual Insurance Co. Building, 49 Wall Street, New York City, and in the Hotel Imperial, showed that the operators made better time with the device in service, as they were compelled to make more exact landings, and thus avoid much of the time frequently wasted in reversals of the ear movement.

Under the present circumstances, therefore, it seems that the proper time has arrived for action. It would be very desirable if, in the investigation of this subject, and the preparation of legislation to deal with it, that competent technical and legal ability were employed. The subject is of a technical character, and some of the legislation already in existence has been worded in so ill-considered a manner as to give the impression that it was phrased in order to prevent the recovery of damages by injured persons.



Aluminium Shot.—Aluminium shot, so called, is simply irregular and rounded pieces of aluminium, some of the smaller of which resemble shot. The material is made by pouring melted aluminium into cold water. The best method is to make a flat-bottomed iron ladle and bore a number of small holes in the bottom. The aluminium is poured through this and the drops issuing from the holes form shot-like pieces when they strike the water. The higher the metal is poured from the water the more irregular the shot, as it flattens when striking the water under this condition.

DOMINION STEEL CORPORATION.

TO enable shareholders to judge the progress made by the Dominion Steel Corporation in its fiscal year as compared with the similar period preceding, President J. H. Plummer has issued in Montreal a circular showing the standing of the Corporation on March 31, 1913, and March 31, 1912, respectively. It is summarized as follows:—

	1913.	1912.
Manufacturing earnings	\$4,714,057	\$3,936,181
Deduct sinking funds, depreciation, etc.	1,009,650	881,642
Interest	1,246,951	1,132,981
Bond discount	84,788	86,387
Net earnings	\$2,372,667	\$1,836,169
Balance April 1	784,945	734,980
Less dividend on preferred	437,500
Less dividend on preferred of constituent companies	560,000	560,000
Less dividend on common	1,277,101	1,225,204
Balance March 31.	\$ 883,012	\$ 784,645

In other words, after paying dividends on preferred stock of \$437,500, not paid in the 1912 year, and paying \$51,897 now in common stock dividends, they had a balance out of last year's profits of \$98,067 to add to its previous surplus, as compared with a corresponding balance of only \$49,965 in 1911-12. In deductions of this kind allowance is also to be made for the larger sums added to reserves in 1912-13.

RECIPROCAL DEMURRAGE.

THAT railway companies should not be allowed to charge shippers for time taken in unloading freight, and still enjoy immunity from charges from shippers in case of delay by the railway companies themselves, is the contention being urged by the representatives of various manufacturing and shipping associations before the Railway Commission. The plaintiffs want a system of "reciprocal demurrage" to be enforced in Canada, this system being now in use in California and other States. By it, when a railway company unnecessarily or negligently delays freight it becomes liable to a fine.

The Manufacturers' Plan.

The application heard by the Commission on June 16 came from the Canadian Manufacturers' Association. It suggested a system of average demurrage, whereby a shipper would be credited with one day, if he unloaded a car

within 24 hours of arrival. If he could not unload within 48 hours, he would be charged demurrage for one day, and so on. At the end of the month, the total number of days credited would be deducted from the total number of days debited, and one dollar per day charged for the remainder. If the credits equalled or exceeded the debits, no charge would be made for the detention of the cars. Evidence on behalf of both applicants and of the railway companies was heard by the Commission, and a decision will be given later.

At present a shipper who allows his car to remain more than the twenty-four hours of free time allowed at terminals before unloading is fined one dollar per day for every day beyond such free time. Last winter the board raised this to \$2 and \$3 for the first and second days for four months as an experiment.

Reciprocal Demurrage Pays.

Mr. J. E. Walsh, of the Canadian Manufacturers' Association, told the board that it had the requisite authority to put such a system as was asked for into effect. Moreover, such action was needed, the shippers now being no better off than a year ago, in spite of the railways' representations. The shippers, he stated, were not trying to make money out of the railways, and were willing that the penalties collected should go to the Crown, if a better service were thereby assured. Reciprocal demurrage had justified its adoption in the United States, and had demonstrated that the railway, rather than the shipper, was responsible for delays.

Car Congestion Coming.

That another period of car congestion was coming was the contention of Mr. T. Marshall, of the Toronto Board of Trade, who read a statement to the effect that the autumn shipping season would probably see such a condition.

Mr. W. S. Tilston, of the Montreal Board of Trade, thought the car service rules should be administered by an official of the board; while Mr. G. E. McIntosh, of the Ontario Fruit Growers' Association, said it was the wish of that association that the average movement of cars would not be less than ten miles per hour, and he gave numerous instances of total loss of fruit shipments through delays.

Slow Railway Movements.

Mr. M. K. Cowan, K.C., for the Canadian Retail Coal Dealers' Association, gave an instance of one shipment of thirteen cars during eleven days to a Hamilton coal firm, when the average movement had been only four miles per day, and followed it with numerous other instances.

Mr. Frank Hawkins, for the Canadian Lumbermen's Association, gave instances of delay in lumber shipments. The association, he stated, would like to see a system of average demurrage established.

Railways Blame Shippers.

On behalf of the railway companies, Mr. Murphy, general superintendent of transportation for the C. P. R., presented statistics to show that the shippers and not the railway companies were responsible for delays in delivery. Mr. Murphy maintained that a 50 per cent. quicker service could be given, if shippers acted promptly in unloading.

Mr. E. W. Beatty, counsel for the C. P. R., also gave figures to show that the company had taken due steps to keep pace with growing traffic in regard to bettering terminal and unloading facilities.

Spending Big Sums.

Over \$18,000,000 had been spent on terminal facilities between 1906 and 1910, and last year \$1,000,000 had been spent on Montreal and Toronto terminals. During the present year \$2,029,700 would be spent at Toronto and \$1,618,000 at Montreal.

G. T. R. Improvements.

On behalf of the G. T. R., Superintendent of Transportation Crombie urged that any delays in delivery were caused for the most part on the American side of the border, rather than on the Canadian side. He said the company was doing its utmost to improve terminal facilities, and during the past year had built 84 miles of sidings.

LENGTHENING THE LIFE OF RAILWAY TIES.

A GROWING interest in the subject of preserving timber against decay is being manifested by the users of railway ties. This is largely due to the rising price of woods such as cedar, which resist decay without any special treatment.

A British firm has recently established a large plant, 28 acres in extent, at Fort Frances, Ont., for preserving ties by means of zinc chloride with the addition of sulphate of alumina to prevent leaching. The prepared solution is forced at high pressure into thoroughly seasoned lumber, so that it permeates every part of the wood, and being aqueous, readily mixes with any slight moisture that may lurk in the inner pores.

Wood treated in this manner has been redneued to sawdust, washed for over an hour, and yet still contained a large proportion of zinc chloride. This compound has the further advantage, as compared with creosote, of cheapness,

and of being colorless and odorless. Moreover the preserved wood may be painted or polished.

The Destruction.

The causes of destruction of railway ties, in order of importance, are decay, mechanical wear and insect pests. Treatment with zinc chloride or creosote will so overcome decay as to more than double the life of a tie, and will keep away the insect pests entirely. Mechanical wear may be reduced by the use of flat tie-plates, of either metal or hardwood, to lessen the cutting of the rail-base, and of screw-spikes to minimize the wear due to spike-pulling. Though at present such devices are not common outside of Europe, yet with the growing employment of soft woods such as jack-pine and spruce, some such precautions will shortly need to be adopted in Canada, perhaps with the anomalous result of giving us a safer track.

ACCIDENT PREVENTION.

A BRITISH Home Office report was issued recently on conferences between employers, operatives and inspectors concerning the fencing of machinery and prevention of accidents in woollen and worsted mills. The report is by James A. Hine, Superintendent Inspector of Factories, North-Eastern Division. Among notes of agreements arrived at, it is stated that, on new machinery, all projecting set screws on continuously revolving parts shall either be countersunk or otherwise efficiently protected, and projecting set screws on existing machinery shall be fenced unless safe by position.

Heavy overhead main driving belts shall be guarded underneath in all cases where there is liability of persons having to pass under them. The fencing for all toothed wheels shall, as far as practicable, completely surround the wheel. Those present were of opinion that it was most desirable that women and girls working among machinery should have their hair put up, or otherwise confined in a net, and agreed to use their best endeavors to see that this was done. Firms are to be urged to keep a supply of sterilized dressings. Cleaning of machinery in motion was considered to be a dangerous practice, and should be avoided. Periodical examination of machinery was recommended.

Mr. Hine states that, in his opinion, the one agreement of all others which would be most beneficial, if properly carried out, was that of the periodical examination of machinery. In his experience, he found that fencing had been provided in most cases, but unfortunately it was not always maintained.

It was obvious that if guards for machinery were provided, it was the intention of those providing them that they should be kept in position, and if periodical examinations were made by some person told off to do this, and defects brought at once to the notice of the managers of mills, in course of time it would be found that the fencing was maintained far more efficiently. It was resolved that the representatives and others should meet again in or about March, 1914.

SMOKE NUISANCE FROM ROUND HOUSES.

THERE is little excuse for dense smoke arising out of the operation of stationary plants, as this can be overcome by the use of mechanical stokers using a fuel adaptable to the class of work required. In the case of round-houses, however, some allowance must be made, as the dense smoke is formed by the lighting of fires and by the banked fires of standing engines. The nuisance resulting is considerable for two reasons.

(1)—Round houses are generally situated within the city limits and near residential districts.

(2)—The ordinary arrangement is to discharge the smoke from the round-house by short stacks. In this way the smoke is more liable to be a nuisance than when discharged from a tall chimney.

The following method of smoke elimination has been used successfully at a 30-stall engine house situated in a residential district of Chicago. The smoke from the stacks is drawn into a main flue by means of exhausters and discharged into a series of washeries, the number depending upon the amount of smoke to be treated. Live steam is also added between the flue and the washery. In washing, the smoke is passed through water under a head of about one inch; this being done in two similar compartments in series. It is estimated that the process will remove practically all the consumed carbon and 75 per cent. of the acids and gases.

LABOR DISPUTES DURING MAY.

THE record of trade disputes maintained by the Department of Labor shows that, as is usual at this season, the majority of the disputes in May occurred pending the adjustment of new wage schedules. They were nearly all of short duration. The mining industry on Vancouver Island was seriously interfered with, more than 3,000 men being out during the whole month, through the continuance of the dispute at Ladysmith and Cumberland

mines, and the closing down of the mines in the Nanaimo district.

A great number of the disputes of the month occurred among workers in the metal trades. The disputes of May affected upwards of 11,500 employees and accounted for the loss of more than 150,000 working days. Disputes affecting various classes of municipal employees in Vancouver and affecting also the hoot and shoe workers in a number of the factories in Quebec, were satisfactorily adjusted during the month through the instrumentality of Boards under the Industrial Disputes Investigation Act. The Department of Labor also assisted in the adjustment of disputes affecting the employees of the Hydro-Electric Commission in Toronto, and affecting the longshoremen in Montreal and St. John, N.B. In the latter case, a board has been established under the Industrial Disputes Investigation Act.

STATISTICS OF PRODUCTION.

THE Bureau of Statistics of the American Iron and Steel Institute has received from the manufacturers details of the production of all kinds of steel ingots and castings in the United States during 1912. It has been necessary to estimate the output of a few plants. The production of ingots and castings by all processes reached the remarkable total of 31,251,303 gross tons, against 23,676,106 tons in 1911, an increase of 7,575,197 tons, or almost 32 per cent. The year of next largest production was 1910, with a total of 26,094,919 tons. Of the production in 1912, 30,284,682 tons were ingots, and 966,621 tons castings, against 23,029,479 tons of ingots and 646,627 tons of castings in 1911.

The production of open-hearth steel was more than double that of Bessemer steel in 1912, the total of the former being 20,780,723 tons (19,909,875 tons of ingots and 870,848 tons of castings), while of Bessemer steel the total was 10,327,901 tons (10,239,151 tons of ingots and 68,750 tons of castings). The production of basic open-hearth steel amounted to 19,197,504 tons of ingots, and 443,998 tons of castings, while the production of acid open-hearth steel was 712,371 tons of ingots, and 426,850 tons of castings.

Drastic Duty Reductions.—Drastic reductions of the House duties in the iron and steel schedule were approved by the Senate Finance Committee on June 14. Ferro-manganese, pig iron, blooms and slags, ingots and billets were placed on the free list, and rates on the basic forms of steel products, all structural steel, and the like were reduced according to a proportionate scale.

Machine Tools and Modern Motor Car Manufacture*

By R. Urtel

The writer of this article makes a special feature of the production cost of motor cars, and points out that although purchasers' demands, as far as satisfactory operation is concerned, are being fully met, a lower manufacturing cost is, or should be the ideal, and this is possible through the assistance of special machine tools of first-class quality, which combine excellence of workmanship and the highest degree of accuracy.

THE motor car industry, after passing through a period of development of unprecedented rapidity, is at the present time undergoing an important change. In former years, the details of the constructional design have undergone constant alterations; now, however, nearly all manufacturers are agreed upon the fundamental principles in the mechanical construction. With the importance of the motor car as a vehicle for practical use increasing year by year, as compared with its employment for pleasure and sporting purposes, the question of price is constantly coming more to the foreground, and progress will only be possible in this respect, when the entire industry moves more in the direction of the simultaneous production of a large series of parts, introducing the exchange system universally by means of wholesale manufacture.

• Series Manufacture and Individual Construction.

This necessitates, however, that the series manufacture should be separated as far as possible from individual construction. The task of satisfying the special requirements of the customer, so far as they deviate from the standard type, is becoming more and more the business of the skilled worker, as is frequently the case in car body construction at the present day. The American motor car industry, which in consequence of the high costs for hand-work was carried on from the beginning by the wholesale production of one or only a few types of uniform construction down to the smallest details and all accessories, has already shown some noteworthy results as regards the reduction in price of the manufactures.

The more individual construction which the German motor car industry gives to its cars has hitherto detracted from the possibility of introducing a further permanent price reduction, notwithstanding the fact that the fundamental principle of all wholesale manufacture, the exchange system, has already been practised for some time past in the larger German motor car factories for the mechanical part of the car at least.

It was necessary, however, not only to raise appreciably the standard of accuracy by the universal application of the limit gauge, but a justification had also to be found for the introduction of wholesale manufacture in the constructional development by simplifying the working processes, adopting the cheapest working methods, and avoiding all handwork as far as possible. It was of importance, here, to benefit by the progress made in the technique of casting, which enabled complicated parts, such as cylinders, for example, to be cast together, at the same time keeping the metal walls thin.

Example of Simplification of Working Methods.

As an example of the simplification of the working methods, as carried out in the N. A. G. Works, the cylinder casting of a four-cylinder motor is drawn between the three milling cutters of a three-spindle machine in one process, thus enabling all level surfaces of the cylinder to be worked simultaneously. The bores in a casting of this kind are also drilled out simultaneously in one process on a four-cylinder drilling machine.

The series manufacture, naturally, only became possible when a certain standard in the constructional development had been attained, since the large series of a given type could not be put in hand before the construction had been tested in every way, and a number of trial cars had given good results in practical use. At the same time, a modern motor car factory must not rest satisfied at the present day in producing cars which meet the modern demands as regards satisfactory operation; they must also possess the advantage of lower manufacturing costs, and this advantage can only be obtained with the assistance of special machine tools of first-class quality which combine excellence in working with the greatest accuracy.

Machine Tool Feature.

As an example of such machines, the gear wheel rounding machine may be cited, which rounds off the flanks of the teeth, this work being done formerly with a hand file which was very expensive. Another machine which allows

great precision in manufacture is the bevel gear planing machine, which produces the flank form of the conical wheels, the involute teeth, by allowing a sector to roll along a plane surface. The employment of the grinding machine was indispensable to the introduction of the exchange system, as the lathe work only allows an accuracy of 1-10th mm. The use of the grinding machine was likewise imperative for hardened bolts and bores, the metal of which is too hard for working by means of steel turning tools.

Material Features.

Much has also been done in connection with the question of materials by introducing case-hardened steels and chrome-nickel steels, which can be hardened, and which alone have made modern motor-car construction possible in view of the exceedingly heavy demands made. By means of case-hardening—i.e., allowing the steel to remain for several hours in a glowing fire of powdered charcoal and subsequently cooling it rapidly, a glass hardness of the outer surface is obtained such as is necessary for gearing pinions, while the core of the material remains tough.

Devices and Causes.

A further important principle of the exchange system—the main feature of modern wholesale manufacture—is the extensive use of fixing devices and gauges by means of which the material can be worked without any preliminary marking. Thus, a fixing device is employed for a Cardan rear axle, and for boring the holes for the four connecting rod screws. The drilling gauges enable drilling machines with a large number of drills to be employed; for example, the 22 holes in a crank case can be drilled at the same time after the drilling gauge has been placed in position. The same can also be done in the construction of the framework, for which all the holes in the pressed metal parts for the entire series of more than 100 frames are drilled in succession, without any marking by means of a drilling gauge. It is, of course, essential to check all finished parts with the greatest care in a special controlling department, with the assistance of very fine measuring instruments, and in addition to limit gauges for shafts and bores, a new apparatus recently perfected, called the minimeter, enables the smallest deviations of a few thousandths of a millimetre to be detected immediately, in a cylinder bore for example.

Assembly Feature.

From the controlling department the separate parts pass to the department for the construction of motors and gearing where the assembling is carried out, all hand work being avoided as far as

*In A. E. G. Journal.

possible. Before the motors are mounted in the frame, however, they are carefully tested as regards their actual output in the testing station. The motors are allowed to run at full load for some hours at very high speeds—frequently more than 2,000 r.p.m.—during which time tests are made in connection with the fuel consumption and other qualities of the motors. When a motor has given satisfactory results in this department it is passed out for mounting in the chassis, and when the latter has been completely assembled, it is subjected to a searching trial over several hundred kilometres of road.

Only by constantly striving to improve and reduce the manufacturing costs will the motor-car industry be capable of dealing with the important tasks which are arising in increasing numbers, in consequence of a more and more extended field of usefulness.



MAMMOTH STEEL PLANT AT LONGUEUIL, QUE.

THE mysterious visit paid to Canada a few weeks ago by Sir Percy Girouard is no longer a mystery, it being now officially announced that the great corporation of which he is a director, the Sir W. G. Armstrong, Whitworth & Co., Ltd. will at once establish mammoth steel works on the South Shore of the River St. Lawrence, across from Montreal, east and south-east of the town of Longueuil, where two hundred and fifty acres of land, giving a water frontage of two thousand feet, have been purchased at a cost of \$400,000, and transferred to the representatives of the Armstrong, Whitworth Company in Montreal.

The trustees of the Sir W. G. Armstrong Company, Limited, are M. J. Butler, formerly vice-president and general manager of the Dominion Steel Corporation, and Mr. George G. Foster, K.C., the first named also being consulting engineer of the new Canadian company. He will have general supervision of the extensive works about to be started.

Some months ago Mr. Butler went to England, and after a minute inspection of the various steel concerns of the British Isles, declared, on his return, that in all probability something of importance might be announced later on, and when the negotiations were advanced a stage, Sir Percy Girouard appeared on the scene. It is only a few days since matters assumed the shape of official certainty.

Amongst those who took a prominent part in securing such an important industry to the municipality of Longueuil, and who purchased the land and secured exemption from taxation for a term of twenty years were J. J. Westgate, presi-

dent and general manager of the Hudson Bay Knitting Company, and W. B. Powell, managing director of the Montreal & Southern Counties Railway, whose tracks will run through the property.

Messrs. Westgate and Powell appeared before the Longueuil Town Council a few days ago, and after full discussion, the request of the corporation, which will soon be given a federal charter, for exemption, was concurred in, and as a part of the 250 acres in question is situated outside the town, this territory will be taken in at an early date. The Town Council was unanimous in granting the twenty years tax exemption to an enterprise which means so much to the town, and, in fact, to the whole of the South Shore from St. Lambert down to Boucherville.

To Build on 70 Acres.

It is announced by the company's representatives, that tenders were already in, and that contracts would be awarded shortly for the erection of the first series of buildings, covering no less than seventy acres, at an estimated cost of \$1,000,000, to be completed and running by the first of May, 1914, and giving employment to 500 skilled mechanics, the number to be increased as the project of the company develops. The machinery to be installed will be secured in Canada, Great Britain and the United States.

Prize for Longueuil.

From the starting point of the negotiations, Mayor H. St. Mars and the Longueuil Town Council have been active in securing such a boon to the town and one and all have been congratulated that so important a unit of the great industrial enterprise of The Sir W. G. Armstrong, Whitworth Co., should be transferred to the Dominion. In reply to a question, it was stated that it was not a warship building enterprise, but rather a vast commercial undertaking, the output being all products of the highest quality of steel. The ore will be supplied by the different countries which now send to the Elswick Works, and affiliated companies in Great Britain. An immense quantity of coal will be required, and it is understood that the Dominion Steel Corporation have already a contract for 70,000 tons to be supplied next season.

The tenders call for the erection of a large building, 500 feet in length, of concrete and steel, together with a number of other edifices, covering twist drill departments, tool steel and hammer department, rolling mills, steel foundry, crucible castings, steel forging, etc.

Subsidiary Concerns.

It is also stated by the promoters of the concern which is so soon to mark a

new era for the South Shore, that a number of subsidiary companies will soon be established, as there are a number of such concerns which will have to locate close to the parent company, or, in other words, close to the company which supplies their raw material.

The Elswick Plant.

The Sir W. G. Armstrong, Whitworth Co., at Elswick, near Newcastle-on-Tyne, employ over 25,000 men, and give a living to 70,000 people. They are occupants of 300 acres of land, and their buildings cover 120 acres, so it will be seen that the amount secured for the Canadian company reaches almost as great an area as the parent concern over the water. Then, again, at Openshaw, Manchester, the company's second plant, they employ over 5,000 men, and provide a living for 20,000. The buildings, there, cover forty acres, while 300 acres are used for the general purposes of the Manchester company. At these works are produced surface plates, screw threads, measuring machines, machine tools, street sweeping machines, etc., so it looks as if the South Shore concern would be a duplicate of the British plants.

South Shore Future.

The land purchased for the new steel plant was originally sold by Mr. James E. Wilder, the transfer being made through the National Trust Co. Mr. Wilder, in an interview, says that he is of the opinion that the South Shore will soon be the freight terminals of all the principal railways, and he has for some time been interested in a proposed tunnel under the St. Lawrence River. The company have a charter, and the plans have been approved by the Government. He further stated that works of this kind were just what were needed to assure the Government of the importance of a tunnel connecting the two shores. He believed that within the next few years there would be other bridges across the St. Lawrence, and one or more tunnels.



SCOTCH IRON-FIRM FAILS.

A CABLE dispatch from Glasgow announces that on June 11, James Watson & Company, members of the Glasgow Pig Iron Market, suspended payment. The firm is of old standing and has connections all over the world. The announcement of its suspension caused a sensation at Glasgow, but no figures have been obtained as to the extent of the liabilities. It was understood that the firm sold heavily against its holdings in Scotch warrants, and was unable to meet its commitments.

MACHINE SHOP METHODS ^A_N^D DEVICES

Unique Ways of Doing Things in the Machine Shop. Readers' Opinions Concerning Shop Practice. Data for Machinists. Contributions paid for.

RIGHT AND WRONG METHOD OF STUD DRIVING.

By J. W. Berrie.

I once had occasion to work alongside a fitter, and we each had to fix a casting to a bulkhead with 22 $\frac{3}{4}$ inch collar studs, as shown in Fig. 1.

I put a nut on the $\frac{3}{4}$ -inch tap, and tapped all holes a standard depth, then fitted a stud to suit the hole; I then withdrew the stud and made the rest like the sample withdrawn, using a split nut to grip stud in vice when necessary

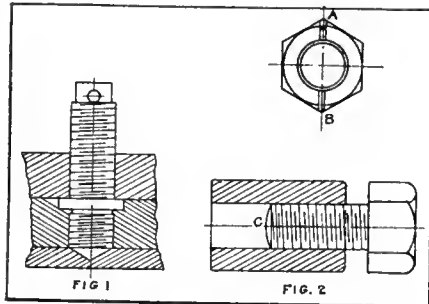

RIGHT AND WRONG WAY OF STUD DRIVING.

to ease with stocks and dies. My method of inserting studs was to use two nuts on stud with a piece of twine between faces, which made a very efficient stud driver. The whole job took three hours.

My friend went his own way in doing his side. He got a stud driver, as shown in Fig. 2, and tapped the holes without getting a uniform depth. The result was that he kept going to the vise to ease the thread, and instead of using a split nut to hold the stud in the vise he used the driver, which increased time in doing the job. When at last he got all the studs in, the casting in place, and the nuts fixed he tried to insert the split pins, but found that every hole had been damaged by the driver stud pressing at point C. The result was a poor job, and it took 9 hours to do it.



A PROBLEM IN BORING.

By J. H. Rodgers.

SOME time ago we had a casting to bore similar to that shown at (A). The most convenient tool in the shop on which to perform the operation was an old gap lathe. In lining up the work, preparatory to boring, the centres (C) and (C') were found to be out of line vertically, nearly 1-16 of an inch, due to the wear upon the headstock spindle. It was not a very difficult proposition to

tilt the tail stock sufficient to bring the two centres in line, but the problem I wish to bring before the reader arose from the remark made by one of the men, that it would make no difference whether the centres were in line or otherwise. An argument that lasted several hours, in fact, long after the job was completed, resulted.

Seven or eight mechanics with experience ranging from five to twenty-five years, offered opinions and quoted precedents to substantiate their statements. When the discussion first started, no two seemed entirely in agreement, and the debate waxed pretty warm on several occasions, and even yet there are those who are not entirely satisfied with the final solution. Many suggestions were offered, the substance of which was that the centres could remain out of line and still bore out an accurate hole. As a result, the problem, which appeared so simple at first sight, brought out arguments that almost stood some of us on our heads, and if the opinions of mechanics, generally, vary as much as they did in this small shop, it will be interesting to have them aired in the columns of Canadian Machinery.

The questions arising out of the discussion were:

- (1)—If the tail stock centre was left 1-16-in. high, and the job completed, what would be the result?
- (2)—Would the two holes be in line with each other?
- (3)—Would they be parallel with each other, and parallel with the base, providing the base was parallel with the shears of the lathe?
- (4)—Would they be tapered?
- (5)—Would they be round?
- (6)—If the work (A) were set up, and the boring bar (B) placed between the centres, and used to centre the work, what result would be obtained?
- (7)—With the centres still out of line, and one cutting tool used to bore both holes, and moving the saddle the full length of the work, what would be the result?



A HANDY TOOL.

By X. Y. Z.

THE removing of drills and chucks with taper shanks from the spindle of a drill press requires the use of a hammer and drift, also both hands, and if the operator is not careful the drill

will fall to the floor, which necessitates the picking of it up. This does not take long to do, but the number of times it is gone through in the course of a week consumes quite a lot of time.

Take a piece of mild steel $\frac{3}{4}$ in. or $\frac{7}{8}$ in. diameter, about 2 feet long, and forge one end to the shape of an ordinary drift, as generally used on a drill press (see sketch). By placing the forged end of this bar in the slot in the spindle of the drill press, and giving a sharp jerk downward on the end of the bar, the drill can be removed very easily without the use of a hammer, besides it

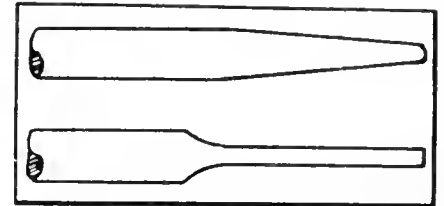

A HANDY TOOL.

leaves one hand free to catch the drill. A little filing may be necessary until the right shape is obtained.

I do not claim this to be a new idea, as it is some years since I first saw it used, but I have often been surprised that it was not more universally adopted, for it is a handy tool and a time saver.



STEEL TARIFF CONDUCTIVE TO FOREIGN SWAY.

M R. J. H. Plummer, president of the Dominion Steel, in reviewing the tariff conditions, at the recent annual meeting of the Corporation, said:—

“Although the Government has not hesitated to admit that the representations made to them respecting the absence of duty on wire rods, in particular, and the anomalies and inconsistencies in the iron and steel tariff in general, are well founded, any effort to cure these defects and to place the industry on the same level as others has been postponed, as we understand for another year.

Wire Rod Manufacture.

One of the questions on which this bears is our wire and nail business. It has always been our desire that we should make wire rods for the wire and nail manufacturers in Canada, but, as I have said more than once, if they are left on the free list, we cannot take this business, and to utilize our rod mill, we

must use the wire rods ourselves as raw material for our own wire and nail mills. These have been so constructed that their capacity can be more than doubled at a very moderate expenditure, and I need scarcely say that with our advantages we are in a good position to compete for this business. There is, however, sufficient wire and nail machinery now in the country, and we would be well satisfied if the promised revision of the tariff removed the unfortunate and anomalous conditions which now affect the wire rod industry. If not removed, they must ultimately force us into competition with those whom we would rather have as customers.

Canada's Foreign Indebtedness.

On the question of the tariff generally, it must be a matter of great regret to everyone interested in the welfare of the country that we are importing such an enormous amount of stuff which could be made in Canada. The growth of our foreign indebtedness is cause for great anxiety, and these imports are contributing largely to this growth. Taking iron and steel products alone, and counting only such as in our present state of development, are, or should be, made in Canada, I learn that our imports for the twelve months ended 31st of March last, amounted to \$1,168,468 tons, valued at \$28,331,349 as against 273,650 tons in 1909, valued at \$7,234,116. This, of course, includes only the less finished articles, as the low average price shows. Taking the whole line of iron and steel and manufactures therefrom, excluding only automobiles, the increase is very striking. The total in 1909 was \$40,717,661, and in the year ending March 31st, 1913, \$138,648,364. These figures are very significant and have at least this satisfaction for us, that they show there is a practically unlimited market for everything we can make.

The Raw Material Feature.

It is, I think, a lamentable feature that a strong tendency of the iron and steel tariff is to build up secondary industries in Canada, depending upon foreign manufacturers for their raw material. I am quite well aware that the Canadian plants cannot as yet cope with the great demand for iron and steel, but what is to be regretted is that people in the business are deterred by tariff conditions from increasing the primary and basic lines of manufacture—that large secondary industries are growing up whose existence may depend on the maintenance of supplies of raw material entering at low duties or even duty free; that these conditions will make it increasingly difficult to get the primary industries established in Canada.

The outcome may be a condition of

industrial dependence on foreign makers of pig iron and of steel in its earlier stages of manufacture, except in the case of a few concerns which start with the coal and ore, and sell the product of wire, nails and other finished articles.

Nature of Plant Extensions.

The truth of what I have stated may be verified by consideration of what has been done with the enormous amount of capital expended in recent years in the enlargement of our Canadian iron and steel plants. We have all spent very large amounts, but, with trifling exceptions, the money has gone either to extend or construct finishing mills, or to increase the amount of steel to be passed through such mills. We have built one furnace for the express purpose of making foundry pig iron, and there have been moderate extensions elsewhere looking to the same object, but apart from these, I know of no instances of extensions for the supply of basic materials.

That all this has a very serious bearing on the future of the steel industry in Canada is plain. One might go farther, and say that it has a serious bearing on the financial position of the Dominion.



C. M. A. ANNUAL MEETING.

At the annual meeting of the Toronto Branch of the Canadian Manufacturers' Association on Thursday, June 12, R. D. Fairbairn, of the R. D. Fairbairn Co., was elected chairman for the coming year, while Mr. T. F. Mony-penny, of the Imperial Varnish and Color Co., was elected vice-chairman.

A. R. Clarke, the retiring chairman, warned manufacturers to restrict their business to the amount of capital invested, and not to attempt to finance on borrowed capital. He touched upon the proposed change in the United States tariff, and found that it had an unsettling effect upon the prosperity of the country. He spoke against any decrease in the Canadian tariff, and asked the members to resist any attempt to turn back the established prosperity of Canada by entering into any reciprocity, or tariff agreement with the United States.

The housing problem was also discussed. The speaker paid tribute to Hon. W. J. Hanna for introducing and fathering the Housing Act in the Legislature, and stated that it had no counterpart in the English-speaking world. As the result of this Act, a number of municipalities are now seeking to develop housing schemes, and it is expected the bill will give a tremendous impetus to manufacturing in Ontario, as every care is being taken to make provision for the health and comfort of the

occupants of these houses, which is essential to workmen.

The retiring chairman congratulated the members of the Technical Commission for the excellent work which they accomplished and the Advisory Board for the work they are now doing. The Fire Prevention Association also was highly commended. Statistics showed that Canada has a greater fire waste than any other country, and this was due to the general apathy among the people in taking preventive measures. He advised the members to give the movement every assistance and to cooperate with other bodies in cleaning up the city.

Officers Elected.

The meeting elected the following officers:—

Executive—S. H. Chapman, W. G. Coulter, H. A. Cowan, H. Daly, F. Diver, C. V. Harding, J. W. Hobbs, S. W. Howard, J. B. McCarter, C. M. Murray, A. F. Park, James Riordan, A. A. Stappels, John Turnbull, Warren Turnbull.

Representatives to the Executive Council—A. R. Clarke, R. J. Copeland, H. Daly, W. L. Edmonds, John Firstbrook, E. Holt Gurney, Sam. Harris, Geo. T. Irving, C. B. Lowndes, J. S. McKinnon, G. B. Meadows, T. F. Mony-penny, J. P. Murray, S. R. Parsons, W. C. Phillips, Thos. Roden, A. S. Rogers, F. A. Rolph, T. A. Russell, J. C. Scott, W. H. Scott, J. F. M. Stewart, W. B. Tindall, A. W. Thomas, J. O. Thom, George W. Watts, C. F. Wheaton, S. M. Wickett.

Representatives to the Canadian National Exhibition Association—S. B. Brush, A. R. Clarke, John Firstbrook, E. J. Freyseng, R. S. Gourlay, S. Harris, G. T. Irving, J. S. McKinnon, J. P. Murray, W. C. Phillips, T. A. Russell, J. O. Thorn.



Arthur S. Herbert has resigned his position as general manager of the Siemens Co., of Canada, and has been appointed general manager of the branch offices of the Siemens Co. in Australia. Mr. Herbert is now in England, but will return to Canada for a few weeks early next month, sailing for Australia from Vancouver about the end of August. He will be succeeded in Canada by Mr. C. A. Ablett, whose name has been closely associated with the electrification of rolling mills in Europe during the past few years, and who recently made a brief investigation of the position of the large steel works of Canada with regard to electric drive. Mr. Ablett will take up his duties in Canada at the beginning of next month, but the appointment dates from June 1.

HEAT ACCUMULATORS IN EXHAUST STEAM TURBINE PLANTS.

A PAPER was recently read before the Junior Institution of Engineers by Mr. Archibald Alison on "Heat Accumulators and their Use in Exhaust Steam Turbine Plants." The author commenced by emphasising the superiority of the condensing engine over the non-condensing, and drew attention to the excellent combination obtained by the use of a reciprocating engine exhausting into a low-pressure turbine. The overall efficiency of such an arrangement was, it was explained, greater than that obtained by any other method of compounding. The author then proceeded to describe the difficulties of utilizing to the fullest extent the energy of steam in certain classes of engines, which worked intermittently. A colliery winding engine was selected as a typical example.

A consideration of the working of a winding engine would, said the lecturer, reveal the difficulties of utilizing to the fullest extent the energy of the steam. The engine only used the steam during a part of each cycle, and in order rapidly to accelerate the tubs, it was usual to admit steam to the cylinders throughout the whole stroke for the first few revolutions. After this, the cut-off occurred earlier and earlier as the winding proceeded. Towards the completion of the wind, steam was completely cut off, and the engine gradually came to rest. An interval of several seconds then elapsed whilst the tubs were changed, and the cycle was then repeated. The effect of the intermittent workings was to cause a great variation to occur in the rate of steam consumption at any instant. In the example chosen, the rate of steam consumption fluctuated between the maximum and minimum values of 105,000 lb. per hour and zero. Were a condensing plant installed, it would be required to work under very disadvantageous conditions, and only inefficient results could be anticipated. The plant would, therefore, be disproportionately large for the normal requirements.

It was common, remarked the author, to find engines of this class exhausting vast quantities of steam uselessly into the atmosphere. The problem of utilizing this waste heat was solved in the year 1901 by Professor Rateau, of Paris, and at the present time, no less than 400,000 brake horse-power was being recovered from exhaust steam. The object of the system introduced by Professor Rateau was to obtain a regular supply of steam in place of the steam intermittently ejected from the primary engine. This aim was attained by passing the exhaust steam into a suitable heat accumulator, whence a continuous

supply of steam was withdrawn to operate a low-pressure turbine. A description was then given of the various forms of heat accumulators employed for this purpose from the early forms to the most modern Rateau-Morrison type. The paper concluded with references to several existing installations.

A SEATLESS BLOW-OFF VALVE.

PROBABLY there is no valve in the plant that gives as much trouble as the blow-off, and when you consider the amount of grit and scale that has to pass over this valve seat every time the boiler is blown down, the only wonder is that it does not give more trouble than is usually experienced. It takes but a short time for a blow-off to dribble away five or ten dollars' worth of hot water once it begins to leak; besides this, the continual expense of re-grinding or renewing valve seats has to be taken into consideration, to say nothing of the time and labor spent in trying to put it in something like serviceable condition.

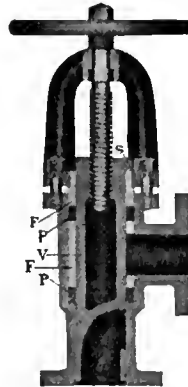

A SEATLESS BLOW OFF VALVE.

Engineers have become so used to blow-off trouble, however, that they naturally look for it, and probably won't be happy without it in some cases. It is one of the necessary evils—so looked upon by engineers, because they can't see any way to remedy it. The thing that gives trouble is the valve seat, and the thing to be overcome is to eliminate the seat, and yet make a tight valve; one that will stay tight, not the first day, or week or month, but for years.

The simplex seatless blow-off valve is claimed to have successfully fulfilled these two requirements; and, as will be seen by the illustration, it is a very simple arrangement. No special directions are required for operating or cleaning, it being only necessary to operate the handwheel. In closing, shoulder (S) on plunger (V) engages loose follower gland (F), and compresses packing (P) above and below port, making an absolutely tight valve.

The Garlock Packing Co., Hamilton, Ont., are the Canadian distributors of this valve.

BRITAIN'S LARGEST CUSTOMERS.

THE Board of Trade states the values of produce and manufactures exported by the United Kingdom to the leading foreign countries and the self-governing Dominions as follows:—

Germany	£40,362,767
Australia	£34,840,701
United States	£30,065,806
France	£25,585,681
Canada	£23,531,311
South Africa	£21,420,912
Holland	£14,281,668
Belgium	£12,193,306
New Zealand	£10,390,334

The Dominions buy very much more in proportion to their population, than do foreign countries.

Samuel Lyon Moyer, First Vice-President of the Lunkenheimer Co., Cincinnati, Ohio, died recently after a protracted illness arising from stomach affection. Mr. Moyer, was born in Cincinnati on August 17, 1874. Sam, as he was known to his host of friends, was a pupil of the First Intermediate School, and later attended the Woodward High School, from which he graduated. He had been connected with the Lunkenheimer Company almost since that time, working his way up to the management by his industry and ability to make friends. As an active and leading member of the National Metal Trades Association Mr. Moyer was well known to people in all parts of the United States and Canada. He also was identified prominently with the American Society of Mechanical Engineers.

Don't be content with doing only your duty. Do more than your duty. It's the horse who finishes a neck ahead who wins the race.

To drill chilled cast iron, a contemporary states that the piece should be laid on a forge, the spot to be chilled covered with sulphur and the blast applied slowly until the sulphur is burned off. The chill will then be drawn and the piece can be drilled.

When lead, tin, soft solder, or aluminum are filed, the file is soon filled with the metal, and it will not cut. It cannot be cleaned like the wood-rasp, by dipping into hot water, or pouring boiling water over it; but if the file and the work are kept thoroughly wet with water, there will be no trouble whatever.

DEVELOPMENTS IN MACHINERY

A Record of New and Improved Machinery Tending Towards Higher Quality and Economical Production in the Machine Shop, Blacksmith Shop or Planing Mill.

VERTICAL CYLINDER BORING MACHINE.

THE machine described and illustrated herewith is designed especially for boring and reaming cylinders, and may be used with equal success on cylinders cast singly, in pairs, or en bloc. In order to obtain the greatest efficiency, each one is built specially for the particular cylinder it is to bore. By this method, it is possible to keep everything close together, providing just enough overhang to spindles, feed to table, width between housings, etc. to accomplish the work which it is to do. It is obvious that by the above method the machine will be refined and simplified, and not only will its efficiency be increased, but at the same time, the cost will be kept down.

The method of boring cylinders vertically is recognized by authorities as the best for several reasons, the principal one being that the chips all drop away from the cut, enabling a greater feed and speed to be maintained. In horizontal boring, the chips lodge on one side of the cylinder, generate unusual heat at the point and cause distortion. This means additional work in finishing to get the bore perfectly round and straight. In plain words, a cylinder can be bored in a vertical position from one-third to one-half faster, and with better results at this increased speed than it can in a horizontal position.

The method recommended for holding the cylinders has been developed from long experience with this type of machine. It consists of a suitable box jig, carrying removable jig plates. The function of these jig plates is to guide and support the spindles through the medium of suitable hardened and ground bushings in the jig plates, and then by having bronze bushings to fit on the spindles, which are slipped into these jig plate bushings after the boring tool has left same, and further support the spindles while they are boring. It is evident that, with this jig bolted to the table and guiding the spindles, the entire machine is tied together, and there is absolutely no chance for deflection under cut.

In designing the machine, the care has been taken to eliminate any tendency to chatter, and to insure a steady, even drive and feed under all conditions. This has been accomplished by the use of worm and worm gear drive with final drive through double pitch

nickel steel spur gears. Spindles are made from special high carbon forgings adjusted for wear by taper bearing with thrust collars which are fully enclosed. It will be noticed that the driving mechanism is entirely enclosed, and runs in oil, eliminating undue wear caused by iron dust getting into these parts. The feed is also through worm and worm gear, with final drive through spur gears. The pitch line of the feed pinions and racks is located exactly under the centre of the spindles, and an extremely accurate knock-off to power feed is provided. Counterweights are attached to table directly in line with the spindles, and table slides are so proportioned that the table does not feed out of the ways, even at the highest point of its travel. A brake is provided

and compact, and arranged to insure maximum output without excessive effort on the part of the operator.

These machines have ample power and strength to handle the heaviest cuts, and the output is limited only by quality of the tool steel used, and the ability of the cylinder castings themselves to stand the strain. In no case, does the ability of the machine itself have any effect on the number of cylinders turned out per day, as they are designed to withstand the strain far in excess of any that they will be called upon to take.

These boring machines are built in several different styles to meet various requirements, our illustration showing a four spindle fixed centre boring unit. The centres, of course, are arranged

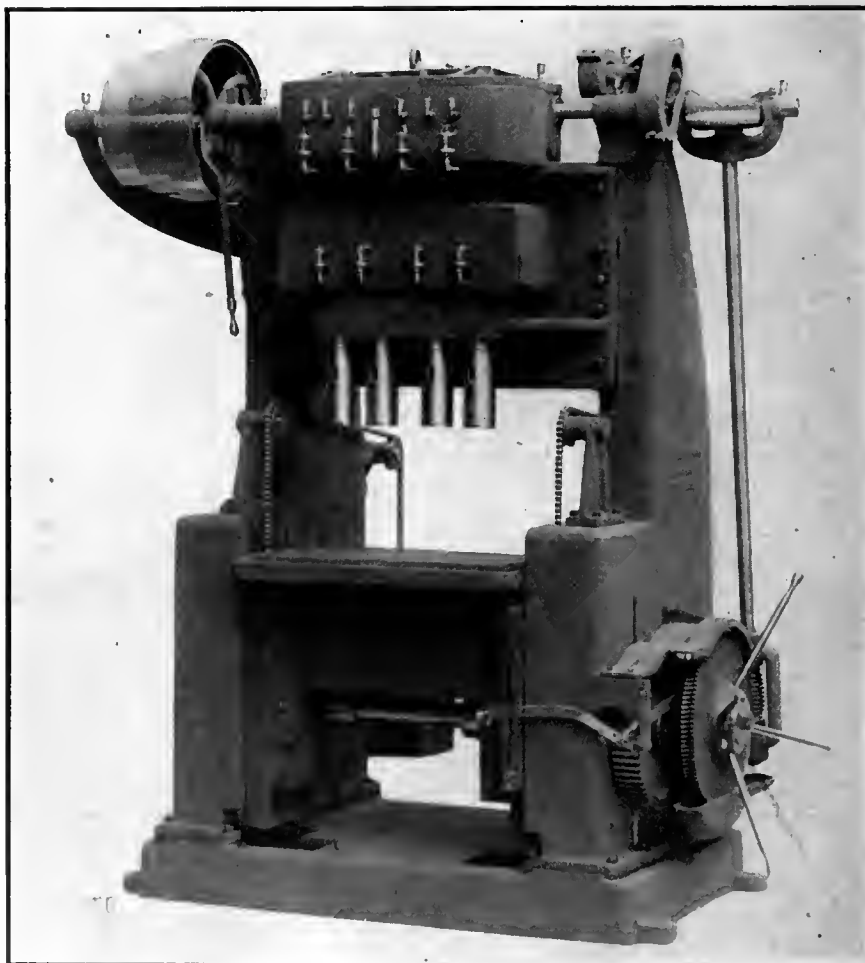

FOOTE-BURT VERTICAL CYLINDER BORING MACHINE.

to stop the spindles quickly at the end of a cut, and prevent scoring the cylinders when the table is returned. The entire operating mechanism is simple

specially to suit requirements, and the machines are built with two, three, four or six spindles to meet various conditions. They are also built adjustable

for centre distance in the two, three and four spindle sizes. The Foote-Burt Co., Cleveland, Ohio, are builders of the above machine.



NEW 1/4 INCH PORTABLE ELECTRIC DRILL.

THE Standard Electric Tool Co., of Cincinnati, Ohio, have developed, and are now placing on the market two types of portable electric drills of 1/4 inch capacity in steel. One is a universal type which operates on both alternating and direct current, and the other is for direct current only. These are in addition to their previous lines of various sizes, ranging from 1/4 inch to 7/8 inch, which were illustrated and described in these columns at an earlier date. The special features are ball bearings throughout, and absolutely oil-proof motor and unit construction.

Electrical features are very powerful motor constructed so as to withstand the abuse and hard service to which machines of this kind are subjected, while at the same time maintaining the highest electrical efficiency. Series motors are employed throughout. All gears are steel generated in Fellows gear shaper. They are case hardened, mounted on ball bearings, and are packed in grease.

The machines are of simple construction, being made up of five units, which

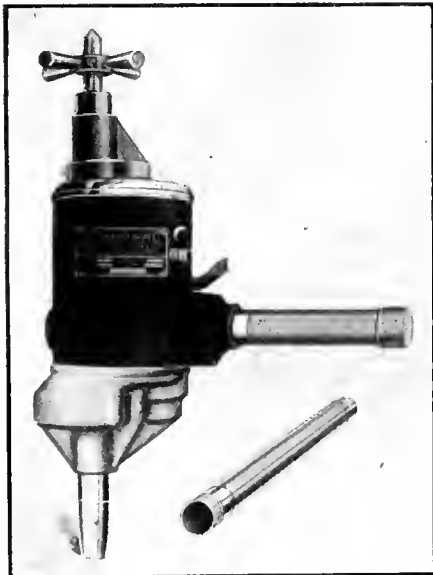

STANDARD ELECTRIC TOOL CO. 1/4 IN. PORTABLE ELECTRIC DRILL.

can be dismembered for inspection without disturbing any of the electrical connections.



RANSOM MOTOR DRIVEN DRY GRINDER.

THE motor driven dry grinder, described and illustrated herewith, is a product of the Ransom Manufacturing

Co., Oshkosh, Wis. It is arranged with the armature shaft extended to receive emery wheels on both ends, and can be supplied with either direct or alternating

power of the engine. The average tonnage capacity was greatly increased by cutting out idle minutes at the yard and delivery points.

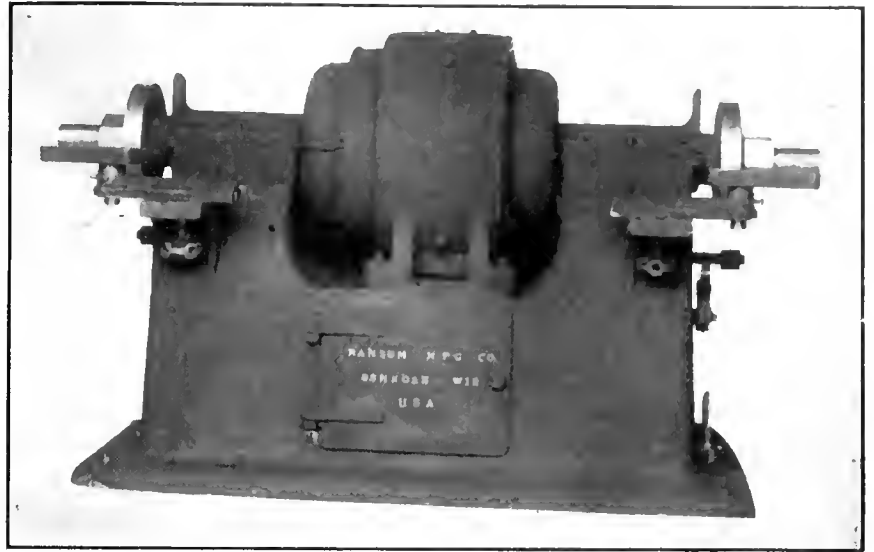

RANSOM MOTOR DRIVEN DRY GRINDER.

current motors, while the bearings may be had equipped with compression grease cups, or with ring oilers. The machine, when arranged for direct current, is provided with the Ransom patent speed controller, which device acts as a safeguard against the possibility of speeding the motor too fast, and allows of the emery wheels being operated right down to the collars. Steel guards with exhaust pipe connections, also safety collars, are furnished when desired. With direct current, the armatures are wound on a sleeve, which, in turn, is pressed on to the arbor, thus making repairs very easy. The motor is also four-poled, besides being interpoled, and the rise in the speed is accomplished by means of an external field resistance. The inter-poling ensures good commutation at high speed.

The total length of the spindle is 80 inches, and the approximate weight of the machine 1,000 pounds. The design permits of two 4 in. by 24 in. emery wheels being employed on heavy steel casting work. A 10 h.p. motor is usually fitted, but one of 15 h.p. can be furnished if desired.



SAVED \$500 PER MONTH.

AN example of the earning power of a motor truck when worked to full capacity is furnished by the records of the Cleveland Macadam Co., which show that their 5-ton dump truck, hauling crushed stone, earned \$500 per month during a period of four and one-half months when it was possible to keep it moving all the time. The truck was loaded by a chute and dumped by the

TWO SPINDLE PLAIN MILLING MACHINE.

THE illustration shows a standard milling machine, having an extra spindle for taking a roughing cut, preceding the regular machine spindle cut. This is a valuable time-saver, as both the roughing and finishing cuts are taken at the one clamping. The roughing spindle has a 1-inch vertical adjust-

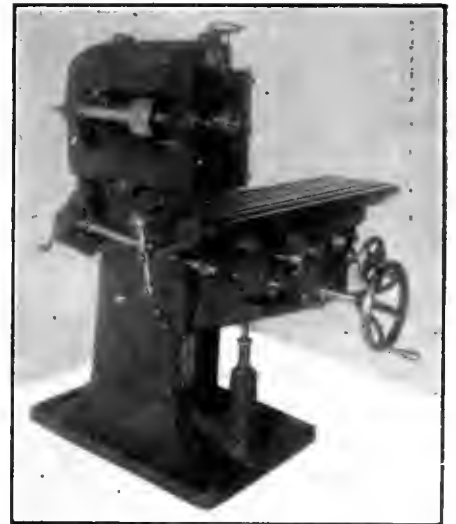

GARVIN TWO-SPINDLE PLAIN MILLING MACHINE.

ment, and is driven from a separate countershaft. The standard adjustments of the machine are:—Automatic table feed, 24 inches; in and out adjustment, 7 inches; vertical adjustment, 19 inches; weight, 1,900 lbs.

The above machine is the No. 13 size of Plain Milling Machine, manufactured by The Garvin Machine Company, New York City.

BORING BAR FOR OFFSET BORING HEAD.

THE Marvin & Casler Co., Canastota, N.Y., have recently put on the market a new boring bar for use with their offset boring head. The latter is shown in fig. 1, while the assembled bar and the detail of its parts are illustrated in figs. 2 and 3, respectively. The offset boring head was specially designed for use on lathes, boring mills, drill presses and milling machines, and the object of the new boring bar is the adaptation of the milling machine to many classes of boring operations on jigs and irregular shaped machine parts, which are generally performed on a lathe. The boring head is usually arranged to be screwed onto the threaded nose of the milling machine spindle. Fig. 1 shows the head with the chuck set off centre by means of the grad-

point along the bar. No adjustment of the cutter (C) is necessary, as the depth the required distance off centre. The application of this boring bar to the

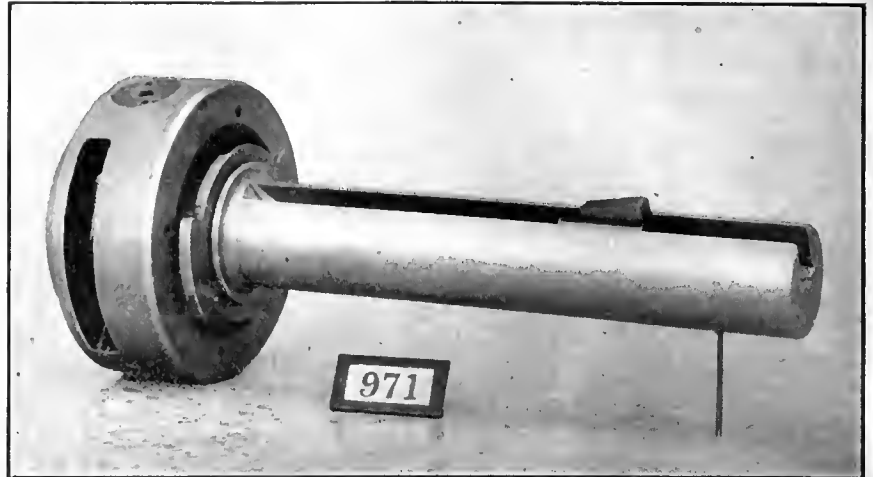

FIG. 2. MARVIN & CASLER BORING BAR ASSEMBLED.

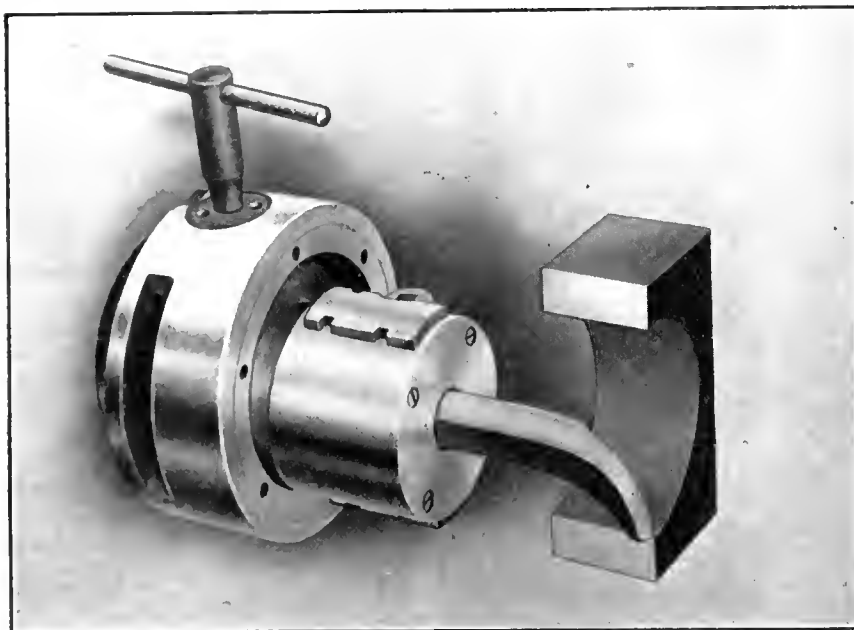

FIG. 1. MARVIN & CASLER OFFSET BORING HEAD.

Marvin & Casler off-set head adapts the equipment to deep hole work.



LEES-BRADNER THREAD MILLING MACHINES.

THIS product of the Lees-Bradner Co., Cleveland, Ohio, represents a most advanced type of thread milling machine, and is constructed to meet the requirements of manufacturers who demand screws and threads of the closest accuracy obtainable and at a minimum cost of production. The machines cut all kinds of worms, single or multiple threads, spirals, and spur gears, being rigidly constructed and having all working parts accessible.

The bed is of box section construction, consideration being given to proper distribution of metal to withstand stresses and avoidance of vibration. The oil pan is a separate casting strongly constructed, the oil tank being integral with the oil pan, and having adequate provision for straining and cleaning the oil. The

uated screw, in order to enable the tool in the chuck to bore a hole of the required size. If desired, the chuck can be brought concentric with the head to enable an ordinary twist drill to be used for starting a hole.

Referring to the parts of the new boring bar, shown in fig. 3. (A) represents the bar, (B) the lock-nut for securing the bar in place, (C) the cutter which is made in various lengths to adapt the bar to a variety of classes of work, (D) the key which fits in the key-way in cutter (C), and (E) a wedge which fits under the cutter. Both the key (D) and the cutter (C) are placed in the dovetail slot in the boring bar, and are secured in place by driving the wedge (E) under them. By this means, the cutter can be secured at any desired

of the cut is controlled by the adjusting screw in the head, which throws the bar

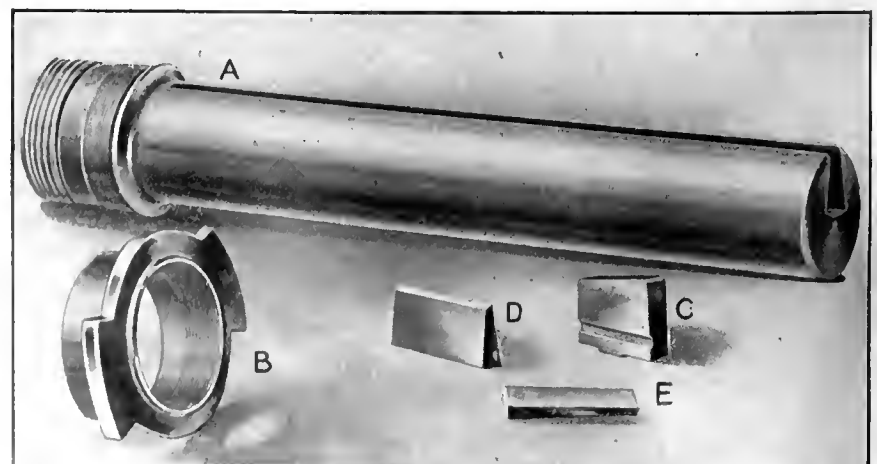

FIG. 3. MARVIN & CASLER BORING BAR DETAIL.

machines are built in three different sizes, namely, 2 ft. 6 in., 4 ft. 6 in., and 8 ft. 6 in., between centres, and have a swing capacity of 10 in. diameter, a chuck capacity of 2¾ in. diameter, a lead of 20 threads per inch to one turn of the work in 96 in., and they will cut

ley in turn drives the cutter head through a system of change gears at its left, giving the cutter 9 different speeds from 37 to 147 revolutions per minute. These cutter speeds are entirely independent of the lead, rotation and quick return of the work. This same pulley,

(not shown) covers them entirely. The head stock is at the left end of the machine, upon which are the change gears for the feed and lead of the work. The power obtained from these is from the feed gear boxes, being taken from a central point going through the change

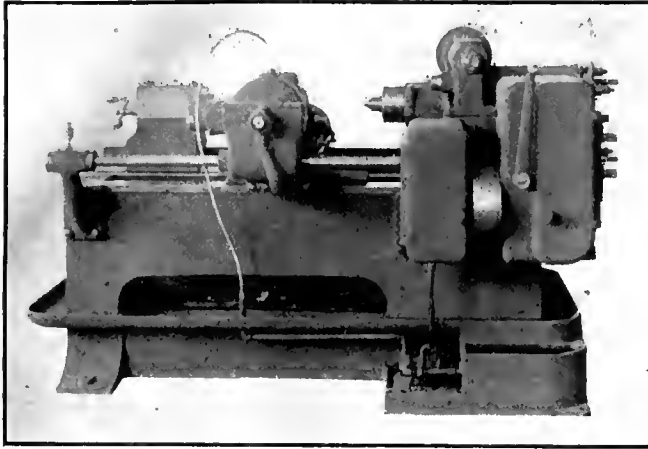

FIG. 2. LEES-BRADNER THREAD MILLING MACHINE.

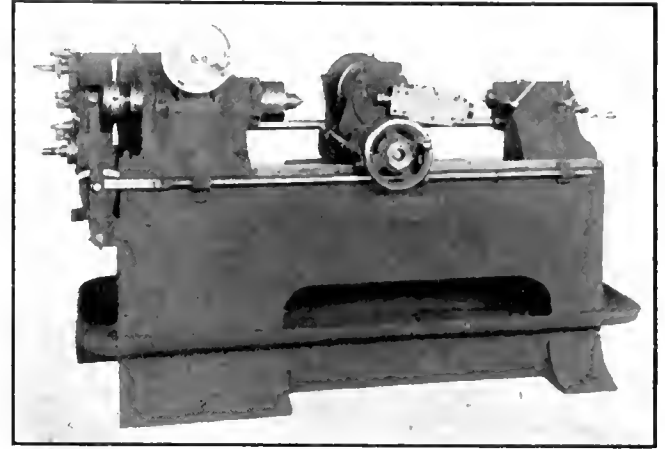

FIG. 1. LEES-BRADNER THREAD MILLING MACHINE.

a steel worm or gear up to and including 1½ in. circular pitch.

The drive is by pulley from counter-shaft, line shaft, or motor; one single belt only being required. This pulley supplies the drive for all movements, including the quick return. The pulley is 12 in. x 3½ in. face. It is situated at the rear of the machine, between cutter drive gear box at the left and feed gear box on the right, and has a friction clutch which releases the drive when necessary, such as when changing cutter speeds. It is not used when changing work or making setting. The pul-

ley through another system of change gears at its right, supplies the rotation for all other movements.

Referring to figure 1, a hand lever with which the trip rod is connected controls all longitudinal movements of the machine. The studs and shafts shown at the left end of the machine are used in connection with the change gears to give the rotation and lead as follows: Upper shaft with square end for the rotation of work, and lower shaft with squared end for the feed; both drives being taken from one central shaft after the gears are in place; a gear shield

gears to the worm wheel drive for rotating the work, and also from this same central point, through change gears to lead screw for the lead. A gear shield (not shown) covers all gears. The gearing on the outside is adjustable for any specific lead, while the gearing noted in figure 2 has to do with the diameter of work and length of time or feed per minute that is required to suit either the material or finish. The index plate shown at the front of the head stock is used for indexing when cutting multiple threads. All locating of cutter to work, such as catching threads, etc., is done by this index mechanism, which has an independent adjustment for the purpose.

The work spindle is one single tool steel forging, with draw-in collet hardened and ground, and capable of taking a shaft 2¾ in. diameter through it. Control is had by spider hand wheel at rear of spindle. Midway on work spindle between two large bronze bearings the rotating worm wheel is located. Bearings and worm wheel are of liberal proportions. The main or work spindle bearings are extremely long, and are made of phosphor bronze.

The hand wheel shown at the front end of cutter slide in figures 1 and 3 controls the adjustment of the cutter, for the depth of cut to be taken, by means of a sensitive micrometer adjustment. The cutter head is of cylindrical design, very rigid, compact, and simple, while the driving mechanism consists of a small number of parts, considering that the cutter head swivels 180 degs. The cutter spindle is a vanadium forging, hand treated. It has substantial bearings, and will thread worms having 1½ in. c.p. in steel. An adjustable,

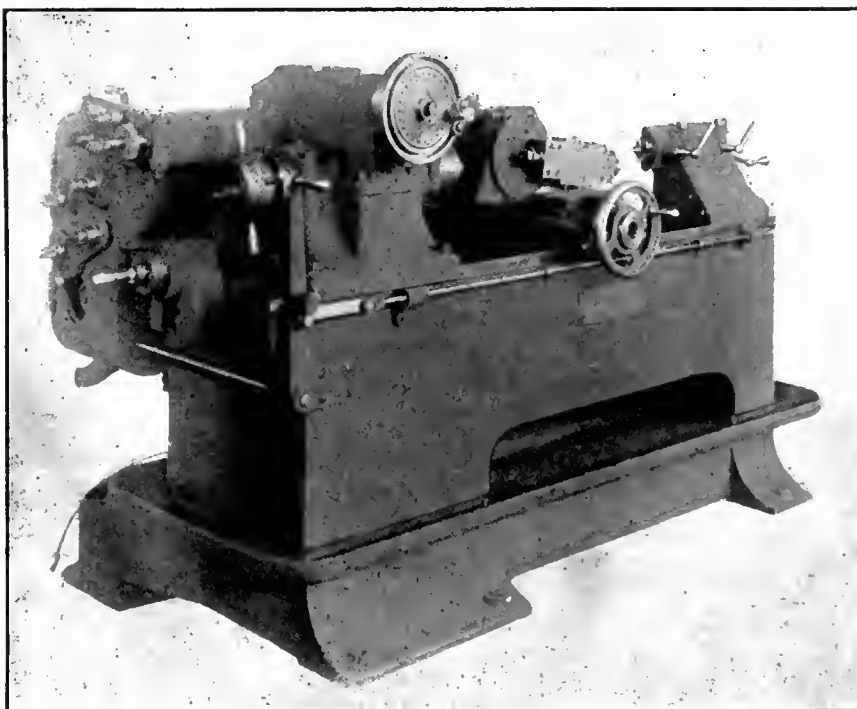

FIG. 3. LEES-BRADNER THREAD MILLING MACHINE.

steady rest, with independent side adjustment, is mounted on the cutter slide to support the long shafts. The tail stock is of rigid design, and is supported on a raised (V) and a flat way on the machine bed.

By referring to figure 4, it will be noted that this front flat way is built up in such a manner that the radial distance from the centre of the work to the bed is constant, thereby giving the greatest stability of bed, without at the same time decreasing the swing of the work. At the rear of the cutter slide,

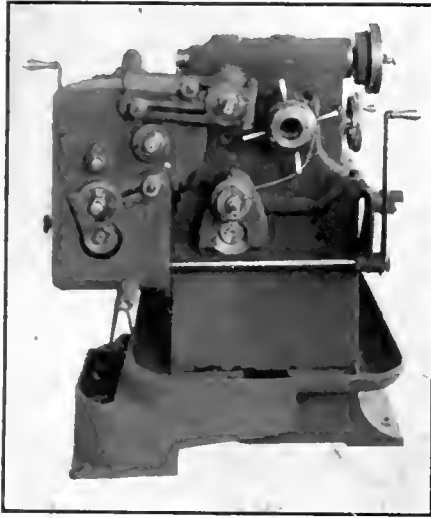

FIG. 5. LEES-BRADNER THREAD MILLING MACHINE.

shown in figure 4, graduations will be noticed on the large diameter of the back plate. These graduations and a fixed vernier are used for setting the cutter head at the proper angle.

U. S. TARIFF BILL.

THE following are the principal changes made by the Senate Finance Committee in the rates of the House Tariff Bill, and presented on June 20 to the Democratic Senate caucus:

Added to the free list—Alizarin, single jute yarns, school books, cement, creosote oil, anthracene and anthracene oil, glaziers' and engravers' diamonds (not cut), miners' diamonds and diamond dust, crude artificial abrasives,

flax, hemp, flax and hemp tow, ambregum valued at not more than 50 cents a pound, indigo colors, pig iron, wrought and scrap iron, ferro manganese and iron in slaps, blooms, hoops or other forms less finished than iron bars, except castings, leather (including patent leather for shoes, harness and saddle leather), asphaltum, limestone rock asphalt, needles for shoe machines, photographic films and moving picture films, cyanide of potash, steel ingots not containing alloy, cattle, sheep and all other domestic live animals suitable for human food, wool of the Angora goat and Alpina, paintings, etc., etelings, sculptures, etc., of a "professional character."

FIRE PROTECTION IN FOUNDRIES.

THE efficiency of automatic sprinklers as a protection against fire in foundries is now generally recognized, and they are being installed in the majority of modern foundry buildings. A sprinkler system not only affords almost total immunity from fire, but pays for itself in from three to five years through the insurance premiums effected. Underwriters fully recognize the reduction of the fire hazard, and will accept a risk in a sprinkler protected factory at something like 75 per cent. less than would obtain in an unprotected risk.

At this juncture of Canadian expansion a bad fire would be disastrous to any foundry, and business would receive a check from which it would take a long time to recover. A sprinkler system can be installed in an old building without in any way interrupting regular work, and it would seem like good management on the part of a foundry owner to take steps to provide sprinkler protection. New foundries should certainly be equipped with automatic sprinklers.

MONSTER CHIMNEY.

A CHIMNEY of unprecedented size has been built at the smelter plant of the Boston and Montana Consolidated Copper and Silver Mining Co., near Great Falls, Montana. It is 506 ft. high above the top of the foundation ring,

and 50 ft. in interior diameter at the top. It is the highest in the world by about 40 ft., and the highest in the United States by 140 ft., the Eastman Kodak chimney being 366 ft. high, and the Orford Copper Co. chimney being 365 feet. Its discharge capacity is 4,000,000 cubic feet of gases per minute. The draught expected is $3\frac{3}{4}$ in. water, with gases at 600 deg. Fah. average. The height was governed solely by the draught requirements, and not by the desideratum of discharging high enough in the air to prevent creation of a nuis-

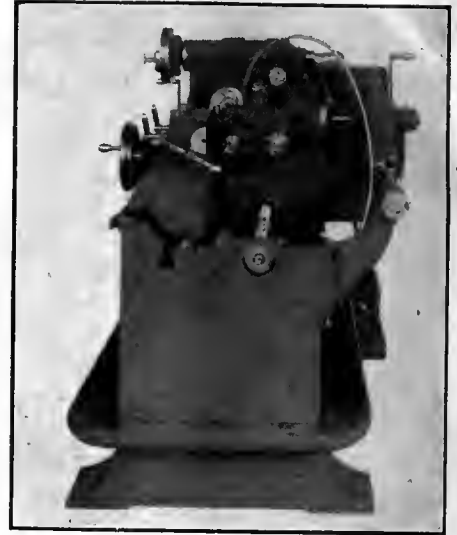
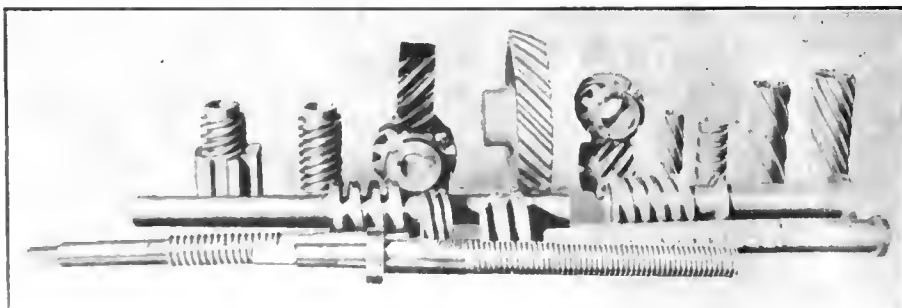

FIG. 4. LEES-BRADNER THREAD MILLING MACHINE.

ance. This latter requirement is met by the existing stack, which is but 186 ft. high, the city of Great Falls being 500 ft. lower than the table land, and the valley being 250 ft. to 300 ft. lower.

ENLARGING SOREL SHIPYARDS.

WORD comes from Ottawa that the Dominion Government is enlarging the usefulness of the much-discussed Federal shipyard at Sorel, Que. Instead of doing small repairs and turning out an occasional vessel for the St. Lawrence and Lower Canada coast work, the Sorel yard is likely before long to be building ships for all Canada. A steamer is under construction in the yards for use on Lake Winnipeg. It will be built in sections, shipped to Port Arthur and thence to Selkirk, and put together there. No satisfactory tenders were received for the construction of the vessel.



LEES-BRADNER THREAD MILLING MACHINE PRODUCTS.

Innisfil Telephone Co., Ltd., incorporated at Toronto, capital \$12,000, to carry on the general business of a telephone company, at Innisfil, Ont.; incorporators: Ebenezer Todd, Walter J. Ralston, etc., Innisfil.

The MacLean Publishing Company LIMITED

(ESTABLISHED 1888.)

JOHN BAYNE MACLEAN - - - - - President
H. T. HUNTER - - - - - General Manager

PUBLISHERS OF

CANADIAN MACHINERY AND MANUFACTURING NEWS

A weekly newspaper devoted to machinery and manufacturing interests, mechanical and electrical trades, the foundry, technical progress, construction and improvement.

H. V. TYRRELL - - - - - Business Manager
PETER BAIN, M.E. - - - - - Editor.
C. W. BYERS - - - - - Associate
A. G. WEBSTER - - - - - Editors

OFFICES:

CANADA
Montreal, Rooms 701-702 Eastern Townships Bank Bldg.
Toronto, 143-149 University Ave., Pboce Main 7324
Winnipeg, 34 Royal Bank Bldg., Phone Garry 2313
Vancouver, H. Hodgson, 2640 Third Ave. West.

GREAT BRITAIN
London, 88 Fleet Street, E.C. Phone Central 12960 E. J. Dodd

UNITED STATES
New York, R. B. Huestis, 115 Broadway, New York, N. Y., Phone 2200 Rector
Chicago, A. H. Byrne Room 607, Marquette Bldg. 140 S. Dearborn St., Chicago

CABLE ADDRESS:
Macpubco, Toronto. Atabek, London, Eng.

SUBSCRIPTION RATE:

Canada, \$2.00; United States, \$2.50; Great Britain, Australia and other colonies, 8s. 6d. per year; other countries, \$3.00. Advertising rates on request.

Subscribers who are not receiving their paper regularly will confer a favor on us by letting us know. We should be notified at once of any change in address, giving both old and new.

Vol. IX. JUNE 26, 1913 No. 23

PRINCIPAL CONTENTS.

Accurate Foundry Cost Control by Economic Methods.....	665-667
Floating Cranes for Panama Canal	667-669
Elevator Accidents, Their Origination and Prevention.....	669-676
General	671-672
Dominion Steel Corporation...Reciprocal Demurrage	
...Lengthening the Life of Railway Ties...Accident	
Prevention...Smoke Nuisance from Roundhouses...	
Labor Disputes During May...Statistics of Production.	
Machine Tools and Modern Motor Car Manufacture.....	673-674
General	674
Mammoth Steel Plant at Longueuil, Que...Scotch	
Iron Firm Falls.	
Machine Shop Methods and Devices	675
Right and Wrong Method of Stud Driving...A	
Problem in Boring...A Handy Tool.	
General	675-677
Steel Tariff Conductive to Foreign Sway...C.M.A.	
Annual Meeting...Heat Accumulators in Exhaust	
Steam Turbine Plants...Seatless Blow-off Valve...	
Britain's Largest Customers.	
Developments in Machinery	678-682
Vertical Cylinder Boring Machine...New 1¼-inch	
Portable Electric Drill...Ransom Motor-Driven Dry	
Grinder...Two-Spindle Plain Milling Machine ...	
Boring Bar for Offset Boring Head...Lees-Bradner	
Thread Milling Machines.	
General	682
U. S. Tariff Bill...Fire Protection in Foundries ...	
Monster Chimney...Enlarging Sorel Shipyard.	
Editorial	683
Selected Market Quotations	684-685
The General Market Conditions and Tendencies	685-686
General	687
Causes of Overheating in Steam Boilers.	
Industrial and Construction News	687-689
Probable Equipment Requirements...Engineering...	
Electrical...Water Works...Building Notes...Wood-	
Working...General Industrial...Railways-Bridges...	
Contracts Awarded...Tenders...Trade Gossip ...	
New Incorporations ... Personal ... Obituary ...	
Catalogues...Book Reviews.	

ROOM AT THE BOTTOM.

SYSTEM and method and, of course, the display of a fair degree of intelligence are what we have a right to expect of mechanics and tradespeople generally, but from a perusal of the accompanying editorial appearing in the "Toronto Weekly Star," and which is here reproduced, it will become at once evident that our ideal is somewhat mythical. Can it be that the disposition to con-

centrate and specialize in some particular line or direction, has an overwhelming tendency to make us not only oblivious of our obligations to others, but even disrespectful. We do not believe such is the case, although we think there is omission in the teaching, with respect to the cultivation of elementary intelligence. All of us can vouch for the "true-to-life" pictures here drawn:

"The other morning I saw a teamster struggling with a horse. The animal was harnessed to a wagon laden with coal sacks, and the firm which had sent the horse and the man on the errand had given the address at which the coal was to be delivered to the man, but not to the horse. This caused trouble. The horse could not make out from the pulls on the reins, from the blows of the whip, from the roars of rage, and the senseless profanity of the driver, which of three houses the coal was to be delivered at. As I watched brute intelligence doing its best to comprehend human ignorance, the idea occurred to me that if this man had possessed sense enough to drive a horse, he probably would not be driving a horse, but would be more profitably employed.

There is an astonishing incompetence shown by those who do ordinary work. It is almost impossible to get a man in Toronto to dig your garden in the spring—no matter how careful you are to stake the work and explain it—without regretting all summer that you did not stand over the job while it was being done. If men come to put tar on the roof of your house, they think of nothing but your roof. They will back a tar-vat on to your lawn and twist it around two or three times, cutting up the sod to an extent that could scarcely be exceeded if they were trying to do all the damage they could. Send for men to repair the chimney of your house, and they will repair it, but they will leave your eaves filled with lime, and your slanting slate roof slobbered with mortar, that the rains of a year will not wash clean.

These men appear to be specialists. They understand only the work they do. They fix your roof, but they ruin your lawn; or they mend your chimney, but they make your roof hideous with daubs of mortar. When the plumber is through, a job is created for the painter and paperhanger. It looks like a conspiracy. The thing you are driving at—your desire to make your house and your grounds all right, all round, in all respects—is not understood and sympathized with by these men who undertake at a price to do something for you. The man who mends the roof hates the lawn.

Your grocer and your butcher and your milkman and your baker want your custom, yet those who do the delivery work for them are too hurried, too busy, too pressed for time, to care a rap for your lawn, your hedges, your flower beds. They deliver the goods with the gore of your garden dripping from their boots. It is commonly said that there is lots of room at the top. There is more room at the bottom than anywhere else. The man who uses intelligence where it is not looked for is on the high road to success."

It will be noted that the examples quoted belong more or less to the jobbing rather than to the wholesale or manufacturing trades, yet, it should not be forgotten that, did opportunity present itself to those employed in large highly organized and systematized factories, it is just possible that they would not make a much better showing. We are all so engrossed, yes, overwhelmed with our particular specialty, that we neglect the cultivation of even a moderate amount of intelligence; our own particular work suffering also, as a result.

SELECTED MARKET QUOTATIONS

Being a record of prices current on raw and finished material entering into the manufacture of mechanical and general engineering products.

FIG IRON.

	Per Ton.	
Foundry No. 1 and 2, f.o.b., Midland	\$19 00	\$19 50
Gray Forge, Pittsburgh	14 65	
Lake Superior, charcoal, Chicago	16 75	
	Mont'l.	Tor'to.
Canadian f'dry, No. 1..	\$21 00	\$20 00
Canadian f'dry, No. 2..	20 50	19 50
Middlesboro, No. 3....	23 50	23 50
Summerlee, No. 2	25 00	26 50
Carron, special	25 00
Carron, soft	25 00
Cleveland, No. 1	24 25	25 00
Clarence, No. 3	23 75	24 50
Jarrow	25 50	25 50
Glengarnock	26 00	26 00
Radnor, charcoal iron.	30 00	34 50
Ferro Nickel pig iron (Soo)	25 00	25 00

BILLETS.

	Per Gross Ton.	
Bessemer billets, Pittsburgh ..	\$26 50	
Open hearth billets, Pittsburgh	26 50	
Forging billets, Pittsburgh	34 00	
Wire rods, Pittsburgh	30 00	

FINISHED IRON AND STEEL.

Per pound to large buyers:

	Cents.
Common bar iron, f.o.b., Toronto..	2.10
Steel bars, f.o.b., Toronto.....	2.20
Common bar iron, f.o.b., Montreal.	2.15
Steel bars, f.o.b., Montreal.....	2.25
Bessemer rails, heavy, at mill....	1.25
Iron bars, Pittsburgh	1.65
Steel bars, Pittsburgh, future	1.40
Tank plates, Pittsburgh, future...	1.45
Beams, Pittsburgh, future	1.45
Angles, Pittsburgh, future	1.45
Steel hoops, Pittsburgh	1.60

Toronto Warehouse f.o.b., Toronto.

	Cents.
Steel bars	2.30
Small shapes	2.45

	Cents
Warehouse import, freight and duty to pay:	
Steel bars	1.95
Structural shapes	2.05
Plates	2.05

Freight, Pittsburgh to Toronto:

18 cents carload; 21 cents less carload.

BOILER PLATES.

	Mont'l.	Tor'to.
Plates, ¼ to ½-in., 100 lbs.	\$2.35	\$2.35
Heads, per 100 lbs.....	2.65	2.95
Tank plates, 3-16 in.	2.60	2.60
Tubes, per 100 ft., 1 inch	9.00	8.50
“ “ 1¼ in.	9.00	8.50
“ “ 1½ “	9.00	9.00
“ “ 1¾ “	9.00	9.00
“ “ 2 “	8.75	8.75
“ “ 2½ “	11.50	11.50
“ “ 3 “	12.00	12.00
“ “ 3¼ “	13.75	13.75
“ “ 3½ “	14.50	14.50
“ “ 4 “	18.00	18.00

BOLTS, NUTS AND SCREWS.

	Per cent.
Stove bolts	80 & 7½
Machine bolts, ¾ and less	65 & 5
Machine bolts, 7-16.....	57½
Blank bolts	57½
Bolt ends	57½
Machine screws, iron, brass	35 p.c.
Nuts, square, all sizes.....	4c per lb off
Nuts, Hexagon, all sizes..	4¼ per lb off
Flat and round head.....	35 per cent.
Fillister head	25 per cent.
Iron rivets	60, 10, -0 off
Wood screws, flathead, bright	85, 10 p.c. off
Wood screws, flathead, brass	75, 10 p.c. off
Wood screws, flathead bronze	70, 10 p.c. off

National-Acme "Milled Products."

Sq. & Hex Head Cap Screws	65 & 10%
Sq. & Hex Head Cap Screws	65 & 10%
Rd. & Fil. Head Cap Screws	45-10-10%
Flat & But. Head Cap Screws	40-10-10%
Finished Nuts up to 1 in. ..	75%
Finished Nuts over 1 in. ..	72%
Semi-Fin. Nuts, up to 1 in...	75%
Semi-Fin. Nuts over 1 in....	72%
Studs.....	65%
Discounts f.o.b., Montreal.	

WROUGHT IRON PIPE.

The following are Toronto jobbers' discounts on pipe in effect from April 21, 1913:

	Butt-weld		Lap-weld	
	Black	Gal.	Black	Gal.
¼ ¾ in.	62	47
½ in.	68	58
¾ to 1½	71½	61½	68½	58½
2 in.	71½	61½	68½	58½
2½ to 4 in. ..	71½	61½	70½	60½
4½ to 6 in.	71½	61½
7, 8, 10 in.	66	54

X Strong P. E.

¼, ¾, 1½ in. ..	56½	46½
¾ to 1½ in. ..	67½	57½
2 to 3 in.	68½	58½
2½ to 4 in.	65	55
4½ to 6 in.	64	56
7 to 8 in.	55	45

XX Strong P. E.

½ to 2 in.	43	33
2½ to 4 in.	43	33

PRICES OF WROUGHT IRON PIPE.

Standard. Nom. Diam.	Price. per ft.	Extra Strong.		D. Ex. Strong.	
		Sizes Ins.	Price per ft.	Size Ins.	Price per ft.
¼ in.	\$.05½	¼ in.	\$.12	½ in.	\$.32
½ in.	.06	¾ in.	.07½	¾ in.	.35
¾ in.	.06	¾ in.	.07½	1 in.	.37
1 in.	.08½	1 in.	.11	1¼ in.	.52½
1¼ in.	.11½	¾ in.	.15	1½ in.	.65
1 in.	.17½	1 in.	.22	2 in.	.91
1¼ in.	.23½	1¼ in.	.30	2½ in.	1.37
1½ in.	.27½	1½ in.	.36½	3 in.	1.86
2 in.	.37	2 in.	.50½	3½ in.	2.30
2½ in.	.58½	2½ in.	.77	4 in.	2.76
3 in.	.76½	3 in.	1.03	4½ in.	3.26
3½ in.	.92	3½ in.	1.25	5 in.	3.86
4 in.	1.09	4 in.	1.50	6 in.	5.32
4½ in.	1.27	4½ in.	1.80	7 in.	6.35
5 in.	1.48	5 in.	2.08	8 in.	7.25
6 in.	1.92	6 in.	2.86
7 in.	2.38	7 in.	3.81
8 in.	2.50	8 in.	4.34
8 in.	2.88	9 in.	4.90
9 in.	3.45	10 in.	5.48
10 in.	3.20
10 in.	3.50
10 in.	4.12

IRON PIPE FITTINGS.

Canadian malleable, 40 per cent.; cast iron, 65; standard bushings, 70; headers, 60; flanged unions, 65; malleable bushings, 65; nipples, 75; malleable, lipped unions, 65.

COKE AND COAL.

Solvay Foundry Coke	5.95
Connellsville Foundry Coke	5.45
Yough, Steam Lump Coal	3.93
Penn. Steam Lump Coal	3.63
Best Slack	2.95
All net ton f.o.b. Toronto.	

OLD MATERIAL.

	Tor'to.	Mont'l.
Copper, light	\$11 50	\$10 50
Copper, crucible	14 50	13 00
Copper, uncr'bled, heavy	12 50	12 00
Copper wire, uncr'bled.	12 50	12 00
No. 1 machine compos'n	11 50	10 50
No. 1 comps'n turnings..	9 50	9 50
New brass clippings	8 50	8 50
No. 1 brass turnings	7 80	7 25
Heavy lead	2 90	3 25
Tea lead	2 50	2 50
Scrap zinc	3 50	3 25

Dealers' purchasing prices.

METALS.

	Mont'l.	Tor'to.
Lake copper	17.00	14.75
Electrolytic copper ..	17.00	14.75
Spelter	6.00	5.50
Lead	5.25	5.10
Tin	50.00	43.00
Antimony	10.00	9.75
Aluminum	21.00	22.00

SMOOTH STEEL WIRE.

No. 6-9 gauge, \$2.35 base; No. 10 gauge, 6c extra; No. 11 gauge, 12 extra;

No. 12 gauge, 20c extra; No. 13 gauge, 30c extra; No. 14 gauge, 40c extra; No. 15 gauge, 55c extra; No. 16 gauge, 70c extra. Add 60c for coppering and \$2 for tinning.

Extra net per 100 lb.—Spring wire; bright soft drawn, 15c; charcoal (extra quality), \$1.25.

SHEETS.

	Mont'l.	Tor'to.
Sheets; black, No. 28....	\$2 85	\$3 00
Canada plates, ordinary,		
52 sheets	2 80	3 00
Canada plates, all bright.	3 70	4 15
Apollo brand, 10¾ oz.		
(American)	4 30	4 20
Queen's Head, 28 B.W.G..	4 50
Fleur-de-Lis, 28 B.W.G..	4 20
Gorbal's Best Best, No. 28	4 45
Viking Metal, No. 28....	4 40

NAILS AND SPIKES.

Standard steel wire nails,		
base	\$2 40	
Cut nails	\$2 60	2 65
Miscellaneous wire nails..	75 per cent.	
Pressed spikes, 5/8 diam.,		
100 lbs.	2 85	

FINE STEEL WIRE.

Discount 25 per cent. List of extras. In 100-lb. lots: No. 17, \$5; No. 18, \$5.50; No. 19, \$6; No. 20, \$6.65; No. 21, \$7; No. 22, \$7.30; No. 23, \$7.65; No. 24, \$8; No. 25, \$9; No. 26, \$9.50; No. 27, \$10; No. 28, \$11; No. 29, \$12; No. 30, \$13; No. 31, \$14; No. 32, \$15; No. 33, \$16; No. 34, \$17. Extraa nat. Tinned wire, Nos. 17-25, \$2; Nos. 26-31, \$4; Nos. 30-34, \$6. Coppered, 75c; oiling, 10c.

MISCELLANEOUS.

	Cents
Putty, 100 lb drums	\$2.70
Red dry lead, 560 lb. casks, per	
cwt.	6.00
Glue, French medal, per lb	0.10
Tarred slaters' paper, per roll...	0.95
Motor gasoline, single bbls., gal..	0.26
Benzine, per gal.	23½
Pure turpentine	0.60
Linseed oil, raw	0.60
Linseed oil, boiled	0.63
Plaster of Paris, per bbl.	2.10
Plumbers' Oakum, per 100 lbs....	3.25
Pure Manila rope	17

The General Market Conditions and Tendencies

This section sets forth the views and observations of men qualified to judge the outlook and with whom we are in close touch through provincial correspondents.

Montreal, June 23, 1913.—Liveliness characterized the machine tool market in Montreal and district this week. Several of the big dealers in supplies report activity and with good outlook for the future. All the large railways of any standing in the United States have loosened their purse strings, and reports are that they have bought freely, including many thousands of tons of rails, nearly 2,000 cars, and about 30 locomotives. Some bridge orders have also been given, and this is an unerring indicator of improved industrial conditions. In Canada, too, some large orders have been placed and others have been promised. We have been told that some good prospective business is nearby in steel plates for both marine and pipe work, while some Government orders are due to be given out any day. A very potent undercurrent of anxiety is abroad regarding the new projected plant of Armstrong-Whitworth Co., who are locating at Longueuil, Que.

Pig Iron and Copper.

The attempts to revive pig iron have been fruitless. Some pleasing prices have been offered consumers, but there were no takers. Still wise ones know

that there has been rejuvenated interest on the part of the consumer, and this must always be construed to mean precisely what it expresses, that there is strength in the market. The output of iron is reported large from various big centres, hence it is reasonable to deduce that it must be in use in some place, and more especially would this be the case with such a learned appearance as the consumers have assumed. Copper is pouring into Europe, and sales have been quite noticeable from all parts of this continent. The man nearby cannot notice the markets like the one inside interested on the outside. Weakness, nevertheless, marks the situation. Lower prices are in vogue, but not enough of a permanency to make a change in the quotations, because when this reaches the eye of the big maker of goods, the price will have resumed a normal condition again. The cause assigned for the lower prices is embodied in the combined reports of industry, politics and finance. There were some breaks during the week which made a net drop in copper of about ½ a cent a pound. To-day the market is sluggish and weak. Copper dropped everywhere, and speculators were no doubt

“stung.” Very few contracts for copper have been placed here for Old Country service, yet daily there are shipments, and thus the visible supply is hidden from the operators on the market. There are seldom changes in bar iron and rails, but the market now is dull and easier. This means that there has been no attempt on the part of any one to “rig” the market. Antimony and spelter are dull and uninteresting. Lead made a slight advance of about an eighth of a cent, and stayed there, while refined spelter took a little spurt, advancing some odd part of a cent. Tin behaved badly and really went to pieces. The British report embodied three factors, namely, unsettled industrial conditions, politics, and a tight money market. The market has been weak all week, with occasional rallies, and transactions of any amount were all for future deliveries. Old material has been easy and dull, with occasional sales to big foundries and steel plants.

Toronto, June 24, 1913.—At the moment of going to press the market in metals is in a most unsettled state, while latest advices report pig iron to have dropped as much as a dollar a ton. The biggest collapse was in tin, the price falling during Monday from \$49 to \$43 a ton, after being as low as \$42. Prices fell all along the line; copper dropping to \$14.75 from \$16.00, lead to \$5.10 and

spelter to \$5.50. What effect this will have can be gauged by the fact that a Canadian firm has enquiries with a local concern for 300,000 tons of copper wire, and is holding off to see if prices will drop further. This is the lowest level reached by copper in many years. Local men attribute it both to stringency of the money market, and to over-supply. If manufacturers are very short, there may be a boom; on the other hand, they may await further reductions. The drop will affect small dealers in old material, their prices having gone down about fifty cents all round. Pig iron has been weakening every day in the States, but local dealers are firm in their assertion that the price of pig here will remain firm.

Bars, Plates, Wire, Etc.

Agents are losing orders in Ontario when terms are strictly adhered to, and only those who can accommodate manufacturers regarding payment are receiving the business. There has been some cutting in prices among Ontario steel firms, which confined to iron bars and minor commodities. Deliveries are improving, and salesmen are finding it to their advantage to cut prices in order to land the business. The U.S. Steel representative reports "business slow; manufacturers feeling their way, and none buying ahead." Regarding the new plant at Ojibway, he reported that it was principally surveying that was going on now, and that construction work was not likely to start before the fall. Business in steel wire is dead in all lines. A fair warehouse business has been done during the week, consisting of small orders picked up all over the country. Money is not so bad as a month ago, but still takes some chasing to get.

The N.T.R. order for machine tools for Transeona shops went chiefly to John Bertram & Sons, the Canada Machinery Corporation, Galt, and A. R. Williams & Co., Toronto.



CAUSES OF OVERHEATING IN STEAM BOILERS.

THE following article is selected from the "Memorandum on Steam Boilers" prepared some time ago by Mr. William Buchan, one of H.M. Inspectors of Factories, and will be found of considerable practical interest to all engaged in steam power plant work, irrespective of relation thereto:

Scale and Sediment.

Feed water often contains solid matter in solution or suspension. As evaporation proceeds, solid matter in solution is deposited as a fine precipitate which under certain conditions forms a hard scale or crust. Sea water

acts in the same way, leaving a deposit of salt. If the feed water is sedimentary, i.e., contains solids in suspension, there will be a deposit of mud within the boiler. It is most important to prevent any accumulation, and the remedies may be classified as follows:—

(1)—Substitution of a pure water supply. (2)—Treatment at the boiler.

(3)—Removal of all scale-forming constituents from the feed water before it enters the boiler. The first remedy, although effectual, is not always practicable, and the second class covers such methods as (a) the systematic cleaning of the boiler and removal of scale; (b) blowing off regularly when the boiler is at work to carry away the

deposit and keep the density below $2\frac{1}{2}$

32, and (c) the addition of a suitable solvent which prevents the deposit forming a hard incrustation. Before using any boiler composition, it is expedient to have the water analysed, and to settle the routine under expert advice, as a composition suitable with one kind of feed water may be useless with another, and it should be remembered that the use of such composition does not remove the necessity for systematic cleaning.

A definite interval cannot be fixed for cleaning and scaling boilers as so much depends on circumstances. For each boiler this interval should be fixed by experience, and the best guide is probably the thickness of deposit, which should not be allowed to exceed a sixteenth of an inch on the main heat-absorbing surfaces; particular attention should consequently be given to the removal of scale from parts exposed to high temperatures, for instance, furnace and firebox crowns and tubes of multitubular and water-tube boilers. These tubes can be kept clean by the use of brushes or tube scrapers of various types, and if the deposit is hard, turbine cleaners can be applied. The latter are operated by water, steam, or compressed air, supplied by a hose, and the rapid succession of blows by the vibrator or milled cutter knocks the scale from the tubes, leaving them practically clean. As nearly all the explosions of water-tube boilers occur at the tubes it is most important that they be kept clean.

Overheating Through Grease.

When exhaust steam is passed into the feed water to heat it, or the oily water of condensation from a condensing engine is used as feed water, grease will be present in the boiler, and as it becomes concentrated on the surface of the flues or tubes, will not only reduce the efficiency of the boiler, but be a positive source of danger, as it may lead

to serious overheating and subsequent collapse of furnace crowns or tubes. A film of grease one-hundredth of an inch thick offers resistance to the passage of heat equal to a steel plate ten inches thick. In other words, grease offers a thousand times the resistance of steel to the passage of heat.

If it were only realized that the apparently harmless film of oil offered as much resistance to the passage of heat as a thick deposit of hard scale, more care would be taken to eliminate it. When oil is present in the feed water, much of it exists in an emulsified condition, i.e., in the form of minute suspended globules. The principal methods now in use for the removal of grease are:

Filtration of feed water. Whether gravitation or pressure filters are used, the feed water passes through some filtering medium, such as canvas or sand. In land boilers this system is not advisable, as a rule, except as an auxiliary to other methods, as the filters only remove the bulk of the oil, but not the finest particles of it.

Separation of grease from the exhaust steam before the steam enters the condenser or heater. A grease separator consists of a metal chamber with a number of baffle plates inside. Owing to the large volume of the separator, and the presence of the baffle plates, the velocity of the exhaust steam is reduced and consequently the bulk of the oil is thrown down. This method gives better results with non-condensing engines than with condensing engines, results being often unsatisfactory with the latter, because of the great velocity of the steam as it passes through the separator.

Chemical treatment of the greasy water and subsequent filtration.—The feed water is automatically treated with correct proportions of suitable reagents which collect the minute globules in a form suitable for removal by filters of wood fibre or sand.

Electrical treatment of the greasy water and subsequent filtration.—The water is allowed to collect in a vat; the passage of an electrical current through the water, by means of metal plates, causes the minute globules to coalesce, and in this form the oil can be efficiently removed by sand filters.

If it is desired to heat the feed water by exhaust steam from which the grease has not been removed, the steam should be conveyed in coils of pipes, and should not, upon any account, be brought into direct contact with the feed water. Where condensers are used, very satisfactory results can be obtained by combining a grease separator (placed between the engine and the condenser), with a good chemical or electrical method and subsequent filtration.

INDUSTRIAL ^A_N^D CONSTRUCTION NEWS

Establishment or Enlargement of Factories, Mills, Power Plants, Etc.; Construction of Railways, Bridges, Etc.; Municipal Undertakings; Mining News.

Engineering

Moose Jaw, Sask.—The Canadian Automobile and Tractor Co. have built a plant here, and will commence immediately.

Acton Vale, Que.—A 100 h.p. boiler will be required for the new factory being built by Alfred Lambert, Ltd., 17 Notre Dame E., Montreal.

Sorel, Que.—A foundry of one storey, 60 x 100 ft., costing \$8,000, will be built for the Sorel Iron Works, Ltd. Builder, William Brown, Marian St., Montreal.

St. Thomas, Ont.—L. E. Ewing, of Findlay, Ohio, is asking the city to guarantee the bonds for \$125,000 of a company to be organized for the manufacture of motor trucks.

Merritton, Ont.—The Merritton Brass Works, over which there has been much

litigation lately, was put up for sale on Thursday, by virtue of a writ of execution.

Stratford, Ont.—The MacDonald Thresher Co. is putting up a \$75,000 addition to its plant. This will increase the present annual output by about \$150,000.

Galt, Ont.—The Galt Brass Mfg. Co. is building an addition to cost \$7000. It will extend its output to include brass goods used in the plumbing and heating trade.

Montreal, Que.—The municipality of Napierville, Que., will receive tenders for a single span bridge, 50 by 20 feet, concrete and steel construction, over Little River. A. Barrett, Secy.-Treas.

Vancouver, B.C.—Arrangements are already being made by Messrs. Foley, Welch, and Stewart, the contractors, to assemble a plant here for the building

of the five-mile tunnel at Roger's Pass, for the C.P.R.

Sarnia, Ont.—The Loughhead Machine Co., will build a machine shop this fall. They are now in the gas and gasoline engine business, having discontinued the hub and spoke works. H. W. Loughhead, manager.

Collingwood, Ont.—The Imperial Steel and Wire Co.'s plant was threatened by fire on Tuesday, June 17th. Owing to the prompt action on the part of the employees, the loss was limited to several hundred dollars.

Guelph, Ont.—The Stewart Sheaf Loader Co. have not decided yet whether they will build their main plant at Guelph or not, but will do so during the month of July. At present, the Winnipeg plant is running to capacity.

Dundas, Ont.—The Chapman Engine and Mfg. Co., makers of gasoline engines

PROBABLE EQUIPMENT REQUIREMENTS

The following is a list of firms who are likely to be in the market for new equipment or material. For further details, reference should be made to the news items.

Electrical Equipment.

Foley, Welch, and Stewart, Contractors, Vancouver, B.C.

Union Carbide Co., of Canada, Welland, Ont.

City Council, Clinton, Ont.

Toronto Hydro Electric Power Co., Toronto.

Fleet Springs Telephone Co., Fleet Springs, Sask.

Waterworks Commission, Orillia, Ont.

City Council, Weyburn, Sask.

Waterworks Equipment.

Town Council, Collingwood, Ont.

City Council, Medicine Hat, Alta.

Town Council, Maple Creek, Sask.

Waterworks Commission, Orillia, Ont.

City Council, Toronto, Ont.

City Council, Manor, Sask.

City Council, Gravenhurst, Ont.

Machine Tools.

Union Carbide Co., of Canada, Welland, Ont.

L. E. Ewing, Findlay, Ohio.

Hammond-Stooker Co., Redcliffe, Alta.

Galt Brass Mfg. Co., Galt, Ont. MacDonald Thresher Co., Stratford, Ont.

Loughhead Machine Co., Sarnia, Ont.

Foley, Welch and Stewart, Contractors, Vancouver, B.C.

La Compagnie, F. X. Drolet, Quebec, Que.

Wood-Working Machinery.

Melfort Planing Mills, Melfort, Sask.

Mitchell and Riddell, Peter St., Hamilton, Ont.

Shelvin-Clarke Lumber Co., Ltd., Fort Frances, Ont.

Mount Benson Lumber Co., Ltd., Nanaimo, B.C.

F. L. Buckley, Sechelt, B.C.

Canadian Puget Sound Lumber Co., Ltd., Victoria, B.C.

Edward Norton, Mount Lehman, B.C.

Riverside Lumber Co., Ltd., Calgary, Alta. (for next spring).

The Beaver Board Co., Buffalo, N.Y., and Thorold, Ont.

Turbine Pumps.

City Council, Sarnia, Ont.

City Council, Collingwood, Ont.

Concrete Mixing Machinery.
Archibald Oliver, Albert, N.B.

Water Mains.

Town Council, Point Claire, Que.

Foundry Supplies.

Sorel Iron Works, Ltd., Sorel, Que.

Chapman Engine and Mfg. Co., Dundas, Ont.

Centrifugal Water Pumps.

Light and Power Department, Regina, Sask.

Waterworks Commission, Orillia, Ont.

Steam Boilers.

Alfred Lambert, Acton Vale, Que.

Waterworks Commission, Orillia, Ont.

Refrigeration Machinery.

Gordon Ironsides and Fares, Ltd., Winnipeg, Man.

Kamloops-Vancouver Meat Co., Kamloops, and Vancouver, B.C.

P. Burns & Co., Ltd., Calgary, Alta.

Incinerators.

City Council, Toronto, Ont.

and well drilling machines, have recently equipped a large plant here, and may eventually be in the market for a considerable number of moulding machines.

Officials of the company estimate they will have a million dollars worth of equipment at Roger's Pass within a few weeks. A large electric plant is to be installed to handle the haulage of rock out of the tunnel, as it is pushed through the mountain.

Electrical

Weyburn, Sask.—The city will extend its electric light plant at a cost of \$15,000.

Clinton, Ont.—The town now owns the electric light plant, and will do the pumping at the water works.

Toronto, Ont.—The city will probably purchase an auxiliary steam plant to be used as an emergency in case of the Hydro-Electric system failing.

Guelph, Ont.—The Light and Heat Commission show a profit for the first four months of the year of \$7,000 from the electric end of the business.

Berlin, Ont.—The Hydro-Electric Commission will value the Central Heating Co.'s plant, which has been offered to the city as an auxiliary plant for \$38,000.

Toronto, Ont.—Power stations are planned by the Ontario Hydro-Electric Power Commission at Windsor, London, Niagara Falls, St. Thomas, Chatham and Dundas.

Ottawa, Ont.—The Ottawa Electric Street Railway Co. will start work on the Preston Street line, and finish it this summer. The rails have already been purchased.

Fleet Springs, Sask.—Equipment will be required by the Fleet Springs Telephone Co., recently incorporated, for a system, costing \$22,000. R. R. Ambler, Norwich, Sask., secretary.

Winnipeg, Man.—F. D. Sullivan, superintendent of Western lines, announces that the C.P.R. will electrify the line between Castlegar and Rossland, B.C., starting the work at once.

Water Works

Manor, Sask.—The town will spend \$1,000 on a waterworks system.

Gravenhurst, Ont.—\$2,000 will be spent on waterworks extensions by the town.

Sarnia, Ont.—Work has commenced on the \$300,000 waterworks system, which will be rushed to completion.

Point Claire, Que.—Tenders will be called shortly for water mains by the town council. B. H. Dupont, engineer, Montreal.

Medicine Hat, Alta.—R. S. Lee, consulting engineer, has recommended the city to add new units to the waterworks plant at a cost of \$15,000.

Toronto, Ont.—The capacity of the waterworks plant at the Island is to be increased from 40,000,000 to 100,000,000 gallons per day. Engineer, Works Commissioner Harris.

Collingwood, Ont.—Willis Chipman, Toronto, who was engaged to report on a waterworks for the town, has recommended a gravity system from Silver Creek on the mountain west of the town, costing \$150,000. This system will likely be adopted. Mayor, Mr. Gilpin.

Building Notes

Montreal, Que.—The Government will erect a drill hall at McGill University, exclusively for the use of students.

Halifax, N.S.—The Government will build a new fort, costing \$150,000, near Purcell's Cove for the protection of Halifax Harbor.

Montreal, Que.—U. H. Dandurand will erect a new ten-storey structure on St. Catharine Street. The estimated cost is \$250,000.

Toronto, Ont.—The Automobile and Supply Co., one of Geo. H. Gooderham's enterprises, will build a five-storey showroom and garage on University Avenue, costing \$150,000, at once.

Wood-Working

Nanaimo, B.C.—The Mount Benson Lumber Co., Ltd., intends to erect a saw mill this summer.

Neustadt, Ont.—The village will loan the Neustadt Furniture Co. \$6,000 to erect a furniture factory.

Montreal, Que.—The sash and door Factory of Messrs. Itzweire & Sarrazin at Ste. Cunegonde, was destroyed by fire Sunday, June 22.

Calgary, Alta.—The Riverside Lumber Co. are building mills in this city, the machinery for which will not be installed until next spring.

Owen Sound, Ont.—The financing of the Superior Match Co., has been completed, and the industry should be in operation in a month. The factory is already built.

Victoria, B.C.—The Canadian Puget Sound Lumber Co., Ltd., Victoria, B.C., is completing plans for a modern combination cedar mill at Esquimalt Harbor.

Melfort, Sask.—The Melfort Planing Mills, which manufacture sash, door, fitting work and fancy cornices, will purchase more machinery for special sash size.

Lethbridge, Alta.—The Carlson lumber and planing mill, with 5,000,000 ft. of lumber, has been purchased for \$2,000,000, and will be known as the Belly River Lumber Co.

Sutton, Que.—The Escanaba Veneer Mills Co., whose plant was burned to the ground last week will not rebuild in Sutton. T. M. Judson, of Escanaba, Mich., is general manager.

Thorold, Ont.—The Beaver Board Co., of Buffalo, have started to build a plant here which will be a duplicate of that in the Ottawa Valley, if not larger. They are in the market for equipment.

Fort Frances, Ont.—It is reported that the Shevlin-Clarke Lumber Co. will erect a third sawmill in the near future. The first mill was finished last year, and the second is now under construction.

Mount Lehman, B.C.—The mill and timber limits of the Matsqui Lumber Co., Mount Lehman, B.C., have been purchased by Edward Norton, who will make extensive improvements by the addition of new machinery.

New Westminster, B.C.—F. L. Buckley, who has a shingle mill at Sechelt, B.C., is organizing a company to establish a planing mill and resaw mill industry at New Westminster, B.C. The name of the new organization will be the Iowa Lumber & Timber Co., Ltd.

General Industrial

Albert, N.B.—Archibald Oliver will enlarge his concrete block plant and install gasoline engines.

Aylmer, Ont.—The ratepayers have given permission for the gas company to increase the size of its feed pipe.

Edmonton, Alta.—The Alsip Brick and Supply Co. will erect a plant in this city. The estimated cost is \$150,000.

Toronto, Ont.—The city will erect four rubbish incinerators and a garbage

Would You Like to Save 80% of Your Insurance Premiums?

Do you know that your insurance company will reduce your present rate nearly 80% if you will comply with one condition?

It is a fact, and by complying with that condition you will enjoy almost total immunity from fire.

That condition is the installation of

Manufacturers' Automatic Sprinklers

We can prove beyond contradiction that our equipment will give you absolute protection from fire and enable you to obtain an insurance rate that will save enough in from three to five years to pay for the complete installation.

Manufacturers' Automatic Sprinklers are standard and are giving protection to many of the largest plants in Canada and the United States.

Let us give you an estimate on equipping either your old plant or your new one.



General Fire Equipment Company, Limited
72 Queen Street East, Toronto, Canada

STEEL CASTINGS

Heavy Castings Up To 20 Tons
Locomotives, Engine Frames, Wheel Centres
and Machinery Castings Our Specialty

Stock Process Steel for Automobile and Light Castings of all Descriptions

PROMPT DELIVERIES

(Annual Capacity, 12,000 tons)

Let us figure on your requirements

THE DOMINION STEEL CASTINGS COMPANY, Limited
HAMILTON, - - - - - ONTARIO

The advertiser would like to know where you saw his advertisement—tell him.

reduction plant, and favors the system used in Columbus, Ohio.

Port Colborne, Ont.—The Cork Works suffered \$10,000 damage on June 19th from fire, the loss is partly covered by insurance.

Brantford, Ont.—The Brantford Cordage Co. will add 100 spinners and other machinery. The new machinery has been ordered.

Weston, Ont.—The Canadian Kodak Co. have bought 25 acres for \$125,000 on which to build a plant. Plans are being prepared.

Glencoe, Ont.—The Glencoe Canning Co. will build a canning factory in the fall. T. J. Medland Co., and T. Loblaw, Toronto, are interested.

Calgary, Alta.—Chas. M. Spencer, of Syracuse, N.Y., has purchased machinery and rented premises for a paper box factory here, to be operating August 1.

Dundas, Ont.—A. S. Parker, former manager of the Canada Wool Stock Co., will build a knitting factory on West King Street.

Sydney Mines, N.S.—The bankhead at No. 2 colliery was destroyed by fire on June 16th, together with picking belt and other machinery, at a loss of \$16,000.

North Transcona, Man.—Fire, June 4, destroyed the plant of the Dominion Tar & Chemical Co. at North Transcona, five miles east of Winnipeg, Man. Loss \$200,000.

Vancouver, B.C.—Three million dollars is the proposed expenditure by the British Columbia Electric Railway Co. on a gas plant to be erected close to the city. Work on the first unit to cost three-quarters of a million, will be started this year.

Brandon, Man.—Herbert H. Clark, of the Clark Linseed Oil and Lead Co. and the Mexican Palm Soap Co., of Kansas City, will establish a flax mill, a soap factory and a paint and varnish factory in Brandon on condition that the city of Brandon lend his company \$130,000.

Guelph, Ont.—The Colonial Knitting Co., is now occupying the four-storey brick building previously occupied by the Guelph Stove Co., in addition to its original plant. It is planned to erect a new factory building during the coming summer, when additional machinery will be installed.

Moose Jaw, Sask.—The International Linseed Co., connected with the Metzger interests of Toledo, Ohio, will establish a flax mill at this point. The excavating work has already commenced. The

mill, when completed, will have a daily capacity of eight thousand bushels of flax.

Welland, Ont.—The Union Carbide Co. of Canada, will erect a plant south of the Page-Hersey plant. The company is capitalized at \$2,000,000, and the factory will cost \$1,000,000. It will employ 100 men. A contract has been closed with the Hydro-Electric Commission for power.

Glencoe, Ont.—Some Toronto wholesale grocers are starting a canning factory in Glencoe, to be known as the Glencoe Canning Co. Among those interested are the T. J. Medland Co., R. Muirhead, of Muirhead's restaurant, and T. Loblaw, of the Loblaw stores. A \$100,000 company has been formed, and a big plant will be erected this fall. For the present season, a factory has been leased, and the company will can tomatoes and apples.

Railways—Bridges

Sherbrooke, Que.—The C.N.R. is considering running a railway to this city.

Calgary, Alta.—The C. P. R. has elaborate plans for depot accommodation and other improvements, costing about \$500,000.

Vancouver, B.C.—Constructional work on the new terminals and union depot for the G.N.R. and N.P.R. Co. will be started next spring.

Quebec, Que.—The postmaster-general is urging the Government to build a tunnel to bring the G.T.P. to Palace Union Station, now being constructed.

Contracts Awarded

Caslo, B.C.—The contract for a new school has been let to J. Daney & Co., of Nelson, B.C., for \$40,000.

Asquith, Sask.—The Eagle Creek Navigation Co. have awarded a contract to R. Galbraith for a steamboat to be used on the Eagle Creek.

Redcliffe, Alta.—The contract has been let by the Hammond-Stooker Co. for a factory to the Loussier Construction Co., Medicine Hat, Alta.

Medicine Hat, Alta.—The International Supply Co. have been awarded contract to drill and construct nine gas wells for the city.

Sault Ste. Marie, Ont.—The City Council have let contracts for sewer construction—"O" to McNamara & Son, and "B" to Tony Pietro.

Victoria, B.C.—Luney Bros., have awarded the contract for the erection of the new normal school at the capital at a figure slightly in excess of \$300,000.

Fredericton, N. B.—The Provincial Government has awarded the firm of Foundations, Ltd., the contract for the sub-structure of the bridge over the Miramichi.

Kentville, N. S.—The town has placed a contract with Heap & Partners, Montreal, for the supply of over 2½ miles of steel pipe for the extension of the waterworks systems.

Eganville, Ont.—Lachance and Co., of Ottawa, have been awarded the contract for constructing a new public building at a cost of \$22,000, to accommodate the post office and customs.

Peterborough, Ont.—The Property Committee has awarded the Read Incinerator Co., of Toronto, the contract for construction of an incinerator with a capacity of 20 tons per day. The cost is estimated to be \$10,000.

Ottawa, Ont.—The contract for building and erecting 40 double lock gates on the Trent Canal, between Trenton and a point 40 miles up the canal, has been awarded by the Government to Roger Miller & Sons, Toronto, at the price of \$25,000.

Wingham, Ont.—The Town Council have let the following contracts:—Steam roller and stone crushing outfit, J. I. Case Co.; storm sewers, T. J. McLean Co., Wingham; building cement reservoir, Frank Prast, Hanover, Ont.; 2,000 ft. water mains, The Guelph Construction Co.

Port Coquitlam, B.C.—Moon and Silverton of Vancouver, were awarded the contract for the installation of the first unit of the city water works system, by the city council on June 17, at the price of \$23,579.50, the work to be completed within six weeks.

Regina, Sask.—Contracts for water mains were awarded to the following companies: The Sykes Co., Neepawa, Man., for trunk mains \$51,049.71; M. S. Holmes, Souris, Man., Northwestern Sec., \$14,520, John Brodt, for S. W. Section, \$20,054, and east end and wholesale district., \$16,704.

Winnipeg, Man.—J. D. Sullivan, chief engineer of C. P. R. Western lines, announces that the contract for the double track tunnel through the Selkirk mountains, which will be five miles in length, has been let to Messrs. Foley Bros. Welch and Stewart, of Vancouver, who were the lowest tenderers.





133529

Vol. 9

Author Jan-June/13

Title Canadian Machinery

UNIVERSITY OF TORONTO
LIBRARY

Do not
remove
the card
from this
Pocket.

Acme Library Card Pocket
Under Pat. "Ref. Index File."
Made by LIBRARY BUREAU

